



PHYSICS

PHYSICS B

PHYSICS C: MECHANICS

**PHYSICS C: ELECTRICITY AND
MAGNETISM**

Course Description

MAY 2008, MAY 2009

The College Board: Connecting Students to College Success

The College Board is a not-for-profit membership association whose mission is to connect students to college success and opportunity. Founded in 1900, the association is composed of more than 5,000 schools, colleges, universities, and other educational organizations. Each year, the College Board serves seven million students and their parents, 23,000 high schools, and 3,500 colleges through major programs and services in college admissions, guidance, assessment, financial aid, enrollment, and teaching and learning. Among its best-known programs are the SAT[®], the PSAT/NMSQT[®], and the Advanced Placement Program[®] (AP[®]). The College Board is committed to the principles of excellence and equity, and that commitment is embodied in all of its programs, services, activities, and concerns.

For further information, visit www.collegeboard.com.

The College Board and the Advanced Placement Program encourage teachers, AP Coordinators, and school administrators to make equitable access a guiding principle for their AP programs. The College Board is committed to the principle that all students deserve an opportunity to participate in rigorous and academically challenging courses and programs. All students who are willing to accept the challenge of a rigorous academic curriculum should be considered for admission to AP courses. The Board encourages the elimination of barriers that restrict access to AP courses for students from ethnic, racial, and socioeconomic groups that have been traditionally underrepresented in the AP Program. Schools should make every effort to ensure that their AP classes reflect the diversity of their student population.

Dear Colleagues:

The College Board has pledged to become a stronger advocate in improving education for America's children. Our nation's college graduation rate is not what it should be and, with your help, we can do something about that. One of the best predictors of college performance is success in an AP[®] course in high school. A study published by the National Center for Educational Accountability has shown that students who succeed on AP Exams benefit academically with better college graduation rates than their fellows.

In 2006, more than 16,000 schools offered high school students the opportunity to take AP courses, and over 1.3 million students then took the challenging AP Exams. These students felt the power of learning come alive in the classroom, and many earned college credit and placement while still in high school. Behind these students were talented, hardworking teachers who are the heart and soul of the Advanced Placement Program[®].

This AP Course Description summarizes the variety of approaches and curricula used in college courses corresponding to the AP course. Teachers have the flexibility to develop their own syllabi and lesson plans, and to bring their individual creativity to the AP classroom. In fact, AP Exams are designed around this flexibility and allow students whose courses vary significantly equal opportunities to demonstrate college-level achievement. Finally, this curricular flexibility is reflected in the AP Course Audit, which identifies elements considered by higher education as essential to a college-level course, providing a consistent standard for disparate AP classes across the world, while not setting forth a mandated AP curriculum.

The College Board is committed to supporting the work of AP teachers. AP workshops and summer institutes, held around the globe, provide stimulating professional development for tens of thousands of teachers each year. The College Board Fellows scholarships provide funds to support many teachers' attendance at these institutes. Teachers and administrators can also visit AP Central, the College Board's online home for AP professionals, at apcentral.collegeboard.com. Here, teachers have access to a growing set of resources, information, and tools, from textbook reviews and lesson plans to electronic discussion groups (EDGs) and the most up-to-date exam information. I invite all teachers, particularly those who are new to the AP Program, to take advantage of these resources.

As we look to the future, the College Board's goal is to broaden access to AP classes while maintaining high academic standards. Reaching this goal will require a lot of hard work. We encourage you to connect students to college and opportunity not only by providing them with the challenges and rewards of rigorous academic programs like AP but also by preparing them in the years leading up to AP courses.

Sincerely,

A handwritten signature in black ink that reads "Gaston Caperton". The signature is written in a cursive style with a large, sweeping initial "G".

Gaston Caperton
President
The College Board

Contents

| | |
|---|----|
| Welcome to the AP Program | 1 |
| AP Courses | 1 |
| AP Exams | 1 |
| AP Course Audit | 1 |
| AP Physics | |
| Introduction | 3 |
| What We Are About: A Message from the Development Committee | 3 |
| The Courses | 3 |
| Course Selection | 5 |
| Instructional Approaches | 6 |
| Laboratory | 7 |
| Importance and Rationale | 7 |
| Implementation and Recommendations | 8 |
| Documenting Laboratory Experience | 9 |
| Physics B | 10 |
| Physics C | 10 |
| Comparison of Topics in Physics B and Physics C | 11 |
| Content Outline for Physics B and Physics C | 12 |
| The Exams | 15 |
| The Free-Response Sections—Student Presentation | 17 |
| Calculators and Equation Tables | 18 |
| Physics B: Sample Multiple-Choice Questions | 20 |
| Answers to Physics B Multiple-Choice Questions | 28 |
| Physics B: Sample Free-Response Questions | 29 |
| Physics C Mechanics: Sample Multiple-Choice Questions | 34 |
| Answers to Physics C Mechanics Multiple-Choice Questions | 38 |
| Physics C Mechanics: Sample Free-Response Questions | 39 |
| Physics C Electricity and Magnetism: Sample Multiple-Choice Questions | 42 |
| Answers to Physics C Electricity and Magnetism Multiple-Choice Questions | 48 |
| Physics C Electricity and Magnetism: Sample Free-Response Questions | 49 |
| AP Program Essentials | 53 |
| The AP Reading | 53 |
| AP Grades | 53 |
| Grade Distributions | 53 |
| Why Colleges Grant Credit, Placement, or Both for AP Grades | 53 |
| Guidelines on Setting Credit and Placement Policies for AP Grades | 54 |
| College and University AP Credits and Placement Policies | 54 |
| AP Scholar Awards | 55 |
| AP Calendar | 55 |
| Exam Security | 55 |
| Teacher Support | 56 |
| AP Central | 56 |
| Online Workshops and Events | 56 |

| | |
|---|----|
| Pre-AP | 57 |
| Pre-AP Professional Development | 57 |
| AP Publications and Other Resources | 58 |
| Free Resources | 58 |
| Priced Publications | 59 |
| Multimedia | 60 |
| Electronic Publications | 61 |

Welcome to the AP® Program

The Advanced Placement Program (AP) is a collaborative effort among motivated students; dedicated teachers; and committed high schools, colleges, and universities. Since its inception in 1955, the Program has enabled millions of students to take college-level courses and exams, and to earn college credit or placement, while still in high school.

Most colleges and universities in the United States, as well as colleges and universities in more than 40 other countries, have an AP policy granting incoming students credit, placement, or both on the basis of their AP Exam grades. Many of these institutions grant up to a full year of college credit (sophomore standing) to students who earn a sufficient number of qualifying AP grades.

Each year, an increasing number of parents, students, teachers, high schools, and colleges and universities turn to the AP Program as a model of educational excellence.

More information about the AP Program is available at the back of this Course Description and at AP Central, the College Board's online home for AP professionals (apcentral.collegeboard.com). Students can find more information at the AP student site (www.collegeboard.com/apstudents).

AP Courses

Thirty-seven AP courses in a wide variety of subject areas are available now. A committee of college faculty and master AP teachers designs each AP course to cover the information, skills, and assignments found in the corresponding college course. See page 2 for a complete list of AP courses and exams.

AP Exams

Each AP course has a corresponding exam that participating schools worldwide administer in May (except for AP Studio Art, which is a portfolio assessment). AP Exams contain multiple-choice questions and a free-response section (either essay or problem solving).

AP Exams are a culminating assessment in all AP courses and are thus an integral part of the Program. As a result, many schools foster the expectation that students who enroll in an AP course will take the corresponding AP Exam. Because the College Board is committed to providing access to AP Exams for homeschooled students and students whose schools do not offer AP courses, it does not require students to take an AP course prior to taking an AP Exam.

AP Course Audit

The AP Course Audit was created at the request of secondary school and college and university members of the College Board who sought a means to provide teachers and administrators with clear guidelines on the curricular and resource requirements that must be in place for AP courses. The AP Course Audit also helps colleges and universities better interpret secondary school courses marked "AP" on students' transcripts. To receive authorization from the College Board to label a course "AP," schools must demonstrate how their courses meet or exceed these requirements, which colleges and universities expect to see within a college-level curriculum.

The AP Program unequivocally supports the principle that each individual school must develop its own curriculum for courses labeled “AP.” Rather than mandating any one curriculum for AP courses, the AP Course Audit instead provides each AP teacher with a set of expectations that college and secondary school faculty nationwide have established for college-level courses. AP teachers are encouraged to develop or maintain their own curriculum that either includes or exceeds each of these expectations; such courses will be authorized to use the “AP” designation. Credit for the success of AP courses belongs to the individual schools and teachers that create powerful, locally designed AP curricula.

Complete information about the AP Course Audit is available at AP Central.

AP Courses and Exams

Art

Art History
Studio Art: 2-D Design
Studio Art: 3-D Design
Studio Art: Drawing

Biology

Calculus

Calculus AB
Calculus BC

Chemistry

Chinese Language and Culture

Computer Science

Computer Science A
Computer Science AB

Economics

Macroeconomics
Microeconomics

English

English Language and Composition
English Literature and Composition

Environmental Science

French

French Language
French Literature

German Language

Government and Politics

Comparative Government and Politics
United States Government and Politics

History

European History
United States History
World History

Human Geography

Italian Language and Culture

Japanese Language and Culture

Latin

Latin Literature
Latin: Vergil

Music Theory

Physics

Physics B
Physics C: Electricity and Magnetism
Physics C: Mechanics

Psychology

Spanish

Spanish Language
Spanish Literature

Statistics

AP Physics

INTRODUCTION

What We Are About: A Message from the Development Committee

The AP Physics Development Committee recognizes that curriculum, course content, and assessment of scholastic achievement play complementary roles in shaping education at all levels. The committee believes that assessment should support and encourage the following broad instructional goals:

1. *Physics knowledge*—Basic knowledge of the discipline of physics, including phenomenology, theories and techniques, concepts, and general principles
2. *Problem solving*—Ability to ask physical questions and to obtain solutions to physical questions by use of qualitative and quantitative reasoning and by experimental investigation
3. *Student attributes*—Fostering of important student attributes, including appreciation of the physical world and the discipline of physics, curiosity, creativity, and reasoned skepticism
4. *Connections*—Understanding connections of physics to other disciplines and to societal issues

The first three of these goals are appropriate for the AP and introductory-level college physics courses that should, in addition, provide a background for the attainment of the fourth goal.

The AP Physics Exams have always emphasized achievement of the first two goals. Over the years, the definitions of basic knowledge of the discipline and problem solving have evolved. The AP Physics courses have reflected changes in college courses, consistent with our primary charge. We have increased our emphasis on physical intuition, experimental investigation, and creativity. We include more open-ended questions in order to assess students' ability to explain their understanding of physical concepts. We structure questions that stress the use of mathematics to illuminate the physical situation rather than to show manipulative abilities.

The committee is dedicated to developing exams that can be graded fairly and consistently and that are free of ethnic, gender, economic, or other bias. We operate under practical constraints of testing methods, allotted time, and large numbers of students at widely spread geographical locations. In spite of these constraints, the committee strives to design exams that promote excellent and appropriate instruction in physics.

THE COURSES

The AP Physics Exams are designed to test student achievement in the AP Physics courses described in this book. These courses are intended to be representative of courses commonly offered in colleges and universities, but they do not necessarily correspond precisely to courses at any particular institution. The aim of an AP

secondary school course in physics should be to develop the students' abilities to do the following:

1. Read, understand, and interpret physical information—verbal, mathematical, and graphical
2. Describe and explain the sequence of steps in the analysis of a particular physical phenomenon or problem; that is,
 - a. describe the idealized model to be used in the analysis, including simplifying assumptions where necessary;
 - b. state the concepts or definitions that are applicable;
 - c. specify relevant limitations on applications of these principles;
 - d. carry out and describe the steps of the analysis, verbally or mathematically; and
 - e. interpret the results or conclusions, including discussion of particular cases of special interest
3. Use basic mathematical reasoning—arithmetic, algebraic, geometric, trigonometric, or calculus, where appropriate—in a physical situation or problem
4. Perform experiments and interpret the results of observations, including making an assessment of experimental uncertainties

In the achievement of these goals, concentration on basic principles of physics and their applications through careful and selective treatment of well-chosen areas is more important than superficial and encyclopedic coverage of many detailed topics. Within the general framework outlined on pages 12–14, teachers may exercise some freedom in the choice of topics.

In the AP Physics Exams, an attempt is made through the use of multiple-choice and free-response questions to determine how well these goals have been achieved by the student either in a conventional course or through independent study. The level of the student's achievement is assigned an AP grade of 1 to 5, and many colleges use this grade alone as the basis for placement and credit decisions.

Introductory college physics courses typically fall into one of three categories, designated as A, B, and C in the following discussion.

Category A includes courses in which major concepts of physics are covered without as much mathematical rigor as in more formal courses, such as *Category B* and *Category C*, which are described below. The emphasis in *Category A* courses is on developing a qualitative conceptual understanding of general principles and models and on the nature of scientific inquiry. Some courses may also view physics primarily from a cultural or historical perspective. *Category A* courses are generally intended for students not majoring in a science-related field. The level of mathematical sophistication usually includes some algebra and may extend to simple trigonometry, but rarely beyond. These courses vary widely in content and approach, and at present there is no AP course or exam in this category. A high school version of a *Category A* course that concentrates on conceptual development and that provides an enriching laboratory experience may be taken by students in the 9th or 10th grade and should provide the first course in physics that prepares them for a more mathematically rigorous AP Physics B or C course.

Category B courses build on the conceptual understanding attained in a first course in physics, such as the *Category A* course described above. These courses provide a systematic development of the main principles of physics, emphasizing problem solving and helping students develop a deep understanding of physics concepts. It is assumed that students are familiar with algebra and trigonometry, although some theoretical developments may use basic concepts of calculus. In most colleges, this is a one-year terminal course including a laboratory component and is not the usual preparation for more advanced physics and engineering courses. However, *Category B* courses often provide a foundation in physics for students in the life sciences, premedicine, and some applied sciences, as well as other fields not directly related to science. AP Physics B is intended to be equivalent to such courses.

Category C courses also build on the conceptual understanding attained in a first course in physics, such as the *Category A* course described above. These courses normally form the college sequence that serves as the foundation in physics for students majoring in the physical sciences or engineering. The sequence is parallel to or preceded by mathematics courses that include calculus. Methods of calculus are used in formulating physical principles and in applying them to physical problems. The sequence is more intensive and analytic than in *Category B* courses. Strong emphasis is placed on solving a variety of challenging problems, some requiring calculus, as well as continuing to develop a deep understanding of physics concepts. A *Category C* sequence may be a very intensive one-year course in college but often will extend over one and one-half to two years, and a laboratory component is also included. AP Physics C is intended to be equivalent to part of a *Category C* sequence and covers two major areas: mechanics, and electricity and magnetism, with equal emphasis on both.

In certain colleges and universities, other types of unusually high-level introductory courses are taken by a few selected students. Selection of students for these courses is often based on results of AP Exams, other college admission information, or a college-administered exam. The AP Exams are not designed to grant credit or exemption for such high-level courses but may facilitate admission to them.

Course Selection

It is important for those teaching and advising AP students to consider the relation of AP courses to a student's college plans. In some circumstances it is advantageous to take the AP Physics B course. The student may be interested in studying physics as a basis for more advanced work in the life sciences, medicine, geology, and related areas, or as a component in a nonscience college program that has science requirements. Credit or advanced placement for the Physics B course provides the student with an opportunity either to have an accelerated college program or to meet a basic science requirement; in either case the student's college program may be enriched. Access to an intensive physics sequence for physics or science majors is another opportunity that may be available.

For students planning to specialize in a physical science or in engineering, most colleges require an introductory physics sequence that includes courses equivalent to Physics C. Since a previous or concurrent course in calculus is often required of students taking Physics C, students who expect advanced placement or credit for

either Physics C exam should attempt an AP course in calculus as well; otherwise, placement in the next-in-sequence physics course may be delayed or even denied. Either of the AP Calculus courses, Calculus AB or Calculus BC, should provide an acceptable basis for students preparing to major in the physical sciences or engineering, but Calculus BC is recommended. Therefore, if such students must choose between AP Physics or AP Calculus while in high school, they should probably choose AP Calculus.

There are three separate AP Physics Exams, Physics B, Physics C: Mechanics, and Physics C: Electricity and Magnetism. Each exam contains multiple-choice and free-response questions. The Physics B Exam is for students who have taken a Physics B course or who have mastered the material of this course through independent study. The Physics B Exam covers topics in mechanics, electricity and magnetism, fluid mechanics and thermal physics, waves and optics, and atomic and nuclear physics; a single exam grade is reported. Similarly, the two Physics C Exams correspond to the Physics C course sequence. One exam covers mechanics; the other covers electricity and magnetism. Students may take either or both exams, and separate grades are reported.

Further descriptions of the AP Physics courses and their corresponding exams in terms of topics, level, mathematical rigor, and typical textbooks are presented in the pages that follow. Information about organizing and conducting AP Physics courses, of interest to both beginning and experienced AP teachers, may be found in the *AP Physics Teacher's Guide*. This publication includes practical advice from successful AP teachers. The 2004 *AP Physics B and Physics C Released Exams* book contains the complete exams, with solutions and grading standards for the free-response sections and sample student responses, as well as statistical data on student performance. For information about ordering these publications and others, see pages 58–61. Additional useful information may be found at AP Central (apcentral.collegeboard.com).

Instructional Approaches

It is strongly recommended that both Physics B and Physics C be taught as second-year physics courses. A first-year physics course aimed at developing a thorough understanding of important physical principles and that permits students to explore concepts in the laboratory provides a richer experience in the process of science and better prepares them for the more analytical approaches taken in AP courses.

However, secondary school programs for the achievement of AP course goals can take other forms as well, and the imaginative teacher can design approaches that best fit the needs of his or her students. In some schools, AP Physics has been taught successfully as a very intensive first-year course; but in this case there may not be enough time to cover the material in sufficient depth to reinforce the students' conceptual understanding or to provide adequate laboratory experiences. This approach can work for highly motivated, able students but is not generally recommended. Independent study or other first-year physics courses supplemented with extra work for individual motivated students are also possibilities that have been successfully implemented.

If AP Physics is taught as a second-year course, it is recommended that the course meet for at least 250 minutes per week (the equivalent of a 50-minute period every day). However, if it is to be taught as a first-year course, approximately 90 minutes per day (450 minutes per week) is recommended in order to devote sufficient time to study the material to an appropriate depth and allow time for labs.

In a school that uses block scheduling, it is strongly recommended that AP Physics B be scheduled to extend over an entire year. A one-year AP course should not be taught in one semester, as this length of time is insufficient for students to properly assimilate and understand the important concepts of physics that are covered in the syllabus. Each of the Physics C courses, but not both, can be taught in one semester.

More detailed descriptions about alternate approaches can be found in the Teacher's Guide. Whichever approach is taken, the nature of the AP course requires teachers to spend time on the extra preparation needed for both class and laboratory. AP teachers should have a teaching load that is adjusted accordingly.

Laboratory

Importance and Rationale

Laboratory experience must be part of the education of AP Physics students and should be included in all AP Physics courses, just as it is in introductory college physics courses. In textbooks and problems, most attention is paid to idealized situations: friction is often assumed to be constant or absent; meters read true values; heat insulators are perfect; gases follow the ideal gas equation. It is in the laboratory that the validity of these assumptions can be questioned, because there the student meets nature as it is rather than in idealized form. Consequently, AP students should be able to:

- design experiments;
- observe and measure real phenomena;
- organize, display, and critically analyze data;
- analyze sources of error and determine uncertainties in measurement;
- draw inferences from observations and data; and
- communicate results, including suggested ways to improve experiments and proposed questions for further study.

Laboratory experience is also important in helping students understand the topics being considered. Thus it is valuable to ask students to write informally about what they have done, observed, and concluded, as well as for them to keep well-organized laboratory notebooks.

Students need to be proficient in problem solving and in the application of fundamental principles to a wide variety of situations. Problem-solving ability can be fostered by investigations that are somewhat nonspecific. Such investigations are often more interesting and valuable than “cookbook” experiments that merely investigate a well-established relationship and which can take important time away from the rest of the course.

Some questions or parts of questions on each AP Physics Exam deal with lab-related skills, such as design of experiments, data analysis, and error analysis, and may distinguish between students who have had laboratory experience and those who have not. In addition, understanding gained in the laboratory may improve students' test performance overall.

Implementation and Recommendations

Laboratory programs in both college courses and AP courses differ widely, and there is no clear evidence that any one approach is necessarily best. This diversity of approaches should be encouraging to the high school teacher of an AP course. The success of a given program depends strongly on the interests and enthusiasm of the teacher and on the general ability and motivation of the students involved.

Although programs differ, the AP Physics Development Committee has made some recommendations in regard to school resources and scheduling. **Since an AP course is a college course, the equipment and time allotted to laboratories should be similar to that in a college course. Therefore, school administrators should realize the implications, in both cost and time, of incorporating serious laboratories into their program. Schools must ensure that students have access to scientific equipment and all materials necessary to conduct hands-on, college-level physics laboratory investigations as outlined in the teacher's course syllabus.**

In addition to equipment commonly included in college labs, students in AP Physics should have adequate and timely access to computers that are connected to the Internet and its many online resources. Students should also have access to computers with appropriate sensing devices and software for use in gathering, graphing, and analyzing laboratory data and writing reports. Although using computers in this way is a useful activity and is encouraged, some initial experience with gathering, graphing, and manipulating data by hand is also important so that students attain a better feel for the physical realities involved in the experiments. And it should be emphasized that simulating an experiment on a computer cannot adequately replace the actual, hands-on experience of doing an experiment.

Flexible or modular scheduling is best in order to meet the time requirements identified in the course outline. Some schools are able to assign daily double periods so that laboratory and quantitative problem-solving skills may be fully developed. A weekly extended or double laboratory period is recommended for labs. It is not advisable to attempt to complete high-quality AP laboratory work entirely within standard 45- to 50-minute periods.

If AP Physics is taught as a second-year physics course, the AP labs should build on and extend the lab experiences of the first-year course. The important criterion is that students completing an AP Physics course must have had laboratory experiences that are roughly equivalent to those in a comparable introductory college course.

Past surveys of introductory college physics courses, both noncalculus and calculus-based, have revealed that on average about 20 percent of the total course credit awarded can be attributed to lab performance; from two to three hours per week are typically devoted to laboratory activities. Secondary schools may have

difficulty scheduling this much weekly time for lab. However, the college academic year typically contains fewer weeks than the secondary school year, so AP teachers may be able to schedule a few more lab periods during the year than can colleges. Also, college faculty have reported that some lab time occasionally may be used for other purposes. Nevertheless, in order for AP students to have sufficient time for lab, at least one double or extended period per week is recommended for all AP Physics courses.

Laboratory activities in colleges and AP courses can involve different levels of student involvement. They can generally be classified as: (1) prescribed or “cookbook,” (2) limited investigations with some direction provided, and (3) open investigations with little or no direction provided. While many college professors believe that labs in the latter two categories have more value to students, they report often being limited in their ability to institute them by large class sizes and other factors. In this respect, AP teachers often have an advantage in being able to offer more open-ended labs to their students.

In past surveys, colleges have cited use of the following techniques to assess student lab performance: lab reports, direct observation, written tests designed specifically for lab, lab-related questions on regular lecture tests, lab practical exams, and maintenance of lab notebooks. When the colleges assessed laboratory skills with written test questions, they reported attempting to assess the following skills in order of decreasing frequency: analysis of data, analysis of errors, design of experiments, and evaluation of experiments and suggestions for future investigations.

A more detailed laboratory guide is available and can be ordered through AP Central. This guide contains descriptions of a number of experiments that typify the type and level of skills that should be developed by AP students in conducting laboratory investigations. The experiments are not mandatory; they can be modified or similar experiments substituted as long as they assist the student in developing these skills. Each edition of the *AP Physics Teacher’s Guide* also provides additional suggestions for the laboratory. The guide mentions specific experiments that other AP teachers have tried and liked and lists publications and other sources of information that may provide additional ideas for low-cost experiments. It will be helpful to experienced AP teachers as well as to those just beginning to teach courses in AP Physics.

Documenting Laboratory Experience

The laboratory is important for both AP and college students. Students who have had laboratory experience in high school will be in a better position to validate their AP courses as equivalent to the corresponding college courses and to undertake the laboratory work in more advanced courses with greater confidence. Most college placement policies assume that students have had laboratory experience, and students should be prepared to show evidence of their laboratory work in case the college asks for it. Such experience should be documented for the AP course by keeping a lab notebook or a portfolio of lab reports. Students should be encouraged to keep copies of this work and any other work from previous lab experience. Presenting evidence of *adequate college-level* laboratory experience to the colleges they attend, as an adjunct to their AP grades, can be very useful to students if they desire credit for or

exemption from an introductory college course that includes a laboratory. Although colleges can expect that most entering AP students have been exposed to many of the same laboratory experiments performed by their own introductory students, individual consultation with students is often used to help determine the nature of their laboratory experience.

Physics B Course

The Physics B course includes topics in both classical and modern physics. A knowledge of algebra and basic trigonometry is required for the course; the basic ideas of calculus may be introduced in connection with physical concepts, such as acceleration and work. Understanding of the basic principles involved and the ability to apply these principles in the solution of problems should be the major goals of the course. Consequently, the course should utilize guided inquiry and student-centered learning to foster the development of critical thinking skills.

Physics B should provide instruction in each of the following five content areas: Newtonian mechanics, fluid mechanics and thermal physics, electricity and magnetism, waves and optics, and atomic and nuclear physics. A content outline and percentage goals for covering each major topic in the exam are on pages 12–14. A more detailed topic outline is contained in the “Learning Objectives for AP Physics,” which can be found on AP Central.

Many colleges and universities include additional topics in their survey courses. Some AP teachers may wish to add supplementary material to a Physics B course. Many teachers have found that a good time to do this is late in the year, after the AP Exams have been given.

The Physics B course should also include a hands-on laboratory component comparable to introductory college-level physics laboratories, with a minimum of 12 student-conducted laboratory investigations representing a variety of topics covered in the course. Each student should complete a lab notebook or portfolio of lab reports.

The school should ensure that each student has a copy of a college-level textbook (supplemented when necessary to meet the curricular requirements) for individual use inside and outside of the classroom. A link to a list of examples of acceptable textbooks can be found on the Physics B course home page on the AP Central Web site. The *AP Physics Teacher’s Guide* includes some additional suggestions for supplementary books and other materials.

Physics C Courses

There are two AP Physics C courses, Physics C: Mechanics, and Physics C: Electricity and Magnetism, each corresponding to approximately a semester of college work. Mechanics is typically taught first, and some AP teachers may choose to teach this course only. If both courses are taught over the course of a year, approximately equal time should be given to each. Both courses should utilize guided inquiry and student-centered learning to foster the development of critical thinking skills and should use introductory differential and integral calculus throughout the course.

Physics C: Mechanics should provide instruction in each of the following six content areas: kinematics; Newton’s laws of motion; work, energy, and power; systems of particles and linear momentum; circular motion and rotation; and oscillations and gravitation.

Physics C: Electricity and Magnetism should provide instruction in each of the following five content areas: electrostatics; conductors, capacitors, and dielectrics; electric circuits; magnetic fields; and electromagnetism.

Content outlines for both courses and percentage goals for covering each major topic in the exams are on pages 12–14. A more detailed topic outline is contained in the “Learning Objectives for AP Physics,” which can be found on AP Central.

Most colleges and universities include in similar courses additional topics such as wave motion, kinetic theory and thermodynamics, optics, alternating current circuits, or special relativity. Although wave motion, optics, and kinetic theory and thermodynamics are usually the most commonly included, there is little uniformity among such offerings, and these topics are not included in the Physics C Exams. The Development Committee recommends that supplementary material be added to Physics C when it is possible to do so. Many teachers have found that a good time to do this is late in the year, after the AP Exams have been given.

Each Physics C course should also include a hands-on laboratory component comparable to a semester-long introductory college-level physics laboratory. Students should spend a minimum of 20 percent of instructional time engaged in hands-on laboratory work. Each student should complete a lab notebook or portfolio of lab reports.

The school should ensure that each student has a calculus-based college-level textbook (supplemented when necessary to meet the curricular requirements) for individual use inside and outside of the classroom. A link to lists of examples of acceptable textbooks can be found on the Physics C course home pages on the AP Central Web site. The *AP Physics Teacher’s Guide* includes some additional suggestions for supplementary books and other materials.

Comparison of Topics in Physics B and Physics C

To serve as an aid for devising AP Physics courses and to more clearly identify the specifics of the exams, a detailed topical structure has been developed that relies heavily on information obtained in college surveys. The general areas of physics are subdivided into major categories on pages 12–14, and for each category the percentage goals for each exam are given. These goals should serve only as a guide and should not be construed as reflecting the proportion of course time that should be devoted to each category.

Also, for each major category, some important subtopics are listed. The checkmarks indicate the subtopics that may be covered in each exam. Questions for the exam will come from these subtopics, but not all of the subtopics will necessarily be included in every exam, just as they are not necessarily included in every AP or college course.

It should be noted that although fewer topics are covered in Physics C than in Physics B, they are covered in greater depth and with greater analytical and mathematical sophistication, including calculus applications.

Content Outline for Physics B and Physics C

A more detailed topic outline is contained in the “Learning Objectives for AP Physics,” which can be found on AP Central.

| Content Area | Percentage Goals for Exams | |
|--|----------------------------|-------------------------|
| | Physics B | Physics C: Mechanics |
| I. Newtonian Mechanics | 35% | 100% |
| A. Kinematics (including vectors, vector algebra, components of vectors, coordinate systems, displacement, velocity, and acceleration) | 7% | 18% |
| 1. Motion in one dimension | √ | √ |
| 2. Motion in two dimensions, including projectile motion | √ | √ |
| B. Newton’s laws of motion | 9% | 20% |
| 1. Static equilibrium (first law) | √ | √ |
| 2. Dynamics of a single particle (second law) | √ | √ |
| 3. Systems of two or more objects (third law) | √ | √ |
| C. Work, energy, power | 5% | 14% |
| 1. Work and work–energy theorem | √ | √ |
| 2. Forces and potential energy | √ | √ |
| 3. Conservation of energy | √ | √ |
| 4. Power | √ | √ |
| D. Systems of particles, linear momentum | 4% | 12% |
| 1. Center of mass | | √ |
| 2. Impulse and momentum | √ | √ |
| 3. Conservation of linear momentum, collisions | √ | √ |
| E. Circular motion and rotation | 4% | 18% |
| 1. Uniform circular motion | √ | √ |
| 2. Torque and rotational statics | √ | √ |
| 3. Rotational kinematics and dynamics | | √ |
| 4. Angular momentum and its conservation | | √ |
| F. Oscillations and gravitation | 6% | 18% |
| 1. Simple harmonic motion (dynamics and energy relationships) | √ | √ |
| 2. Mass on a spring | √ | √ |
| 3. Pendulum and other oscillations | √ | √ |
| 4. Newton’s law of gravity | √ | √ |
| 5. Orbits of planets and satellites | | |
| a. Circular | √ | √ |
| b. General | | √ |

| <i>Content Area</i> | <u><i>Percentage Goals for Exams</i></u> | |
|--|--|------|
| | <i>Physics B</i> | |
| II. Fluid Mechanics and Thermal Physics | 15% | |
| A. Fluid Mechanics | 6% | |
| 1. Hydrostatic pressure | √ | |
| 2. Buoyancy | √ | |
| 3. Fluid flow continuity | √ | |
| 4. Bernoulli's equation | √ | |
| B. Temperature and heat | 2% | |
| 1. Mechanical equivalent of heat | √ | |
| 2. Heat transfer and thermal expansion | √ | |
| C. Kinetic theory and thermodynamics | 7% | |
| 1. Ideal gases | | |
| a. Kinetic model | √ | |
| b. Ideal gas law | √ | |
| 2. Laws of thermodynamics | | |
| a. First law (including processes on pV diagrams) | √ | |
| b. Second law (including heat engines) | √ | |
| III. Electricity and Magnetism | 25% | 100% |
| A. Electrostatics | 5% | 30% |
| 1. Charge and Coulomb's law | √ | √ |
| 2. Electric field and electric potential (including point charges) | √ | √ |
| 3. Gauss's law | | √ |
| 4. Fields and potentials of other charge distributions | | √ |
| B. Conductors, capacitors, dielectrics | 4% | 14% |
| 1. Electrostatics with conductors | √ | √ |
| 2. Capacitors | | |
| a. Capacitance | √ | √ |
| b. Parallel plate | √ | √ |
| c. Spherical and cylindrical | | √ |
| 3. Dielectrics | | √ |
| C. Electric circuits | 7% | 20% |
| 1. Current, resistance, power | √ | √ |
| 2. Steady-state direct current circuits with batteries and resistors only | √ | √ |
| 3. Capacitors in circuits | | |
| a. Steady state | √ | √ |
| b. Transients in RC circuits | | √ |

*Physics C:
Electricity and
Magnetism*

| <i>Content Area</i> | <i>Percentage Goals for Exams</i> | |
|---|-----------------------------------|---|
| | <i>Physics B</i> | <i>Physics C: Electricity and Magnetism</i> |
| D. Magnetic Fields | 4% | 20% |
| 1. Forces on moving charges in magnetic fields | √ | √ |
| 2. Forces on current-carrying wires in magnetic fields | √ | √ |
| 3. Fields of long current-carrying wires | √ | √ |
| 4. Biot–Savart law and Ampere’s law | | √ |
| E. Electromagnetism | 5% | 16% |
| 1. Electromagnetic induction (including Faraday’s law and Lenz’s law) | √ | √ |
| 2. Inductance (including LR and LC circuits) | | √ |
| 3. Maxwell’s equations | | √ |
| IV. Waves and Optics | 15% | |
| A. Wave motion (including sound) | 5% | |
| 1. Traveling waves | √ | |
| 2. Wave propagation | √ | |
| 3. Standing waves | √ | |
| 4. Superposition | √ | |
| B. Physical optics | 5% | |
| 1. Interference and diffraction | √ | |
| 2. Dispersion of light and the electromagnetic spectrum | √ | |
| C. Geometric optics | 5% | |
| 1. Reflection and refraction | √ | |
| 2. Mirrors | √ | |
| 3. Lenses | √ | |
| V. Atomic and Nuclear Physics | 10% | |
| A. Atomic physics and quantum effects | 7% | |
| 1. Photons, the photoelectric effect, Compton scattering, x-rays | √ | |
| 2. Atomic energy levels | √ | |
| 3. Wave-particle duality | √ | |
| B. Nuclear physics | 3% | |
| 1. Nuclear reactions (including conservation of mass number and charge) | √ | |
| 2. Mass–energy equivalence | √ | |

Laboratory and experimental situations: Each exam will include one or more questions or parts of questions posed in a laboratory or experimental setting. These questions are classified according to the content area that provides the setting for the situation, and each content area may include such questions. These questions generally assess some understanding of content as well as experimental skills, as described on the following pages.

Miscellaneous: Each exam may include occasional questions that overlap several major topical areas or questions on miscellaneous topics such as identification of vectors and scalars, vector mathematics, graphs of functions, history of physics, or contemporary topics in physics.

T H E E X A M S

The AP Physics B Exam is 3 hours long, divided equally between a 70-question multiple-choice section and a free-response section. The two sections are weighted equally, and a single grade is reported for the B Exam.

The free-response section will usually contain 6 or 7 questions. Examples of possible formats are 2 questions of about 17 minutes each and 5 shorter questions of about 11 minutes each, or 4 questions of about 17 minutes each and 2 shorter questions of about 11 minutes each. However, future exams might include a combination of questions of other lengths.

Each Physics C Exam is 1 hour and 30 minutes long. A student may take either or both exams, and separate grades are reported for each. The time for each exam is divided equally between a 35-question multiple-choice section and a free-response section; the two sections are weighted equally in the determination of each grade. The usual format for each free-response section has been 3 questions, each taking about 15 minutes. However, future exams might include a larger number of shorter questions.

The percentages of each exam devoted to each major category are specified in the preceding pages. Departures from these percentages in the free-response section in any given year are compensated for in the multiple-choice section so that the overall topic distribution for the entire exam is achieved as closely as possible, although it may not be reached exactly.

Some questions, particularly in the free-response sections, may involve topics from two or more major categories. For example, a question may utilize a setting involving principles from electricity and magnetism or atomic and nuclear physics, but parts of the question may also involve the application of principles of mechanics to this setting, either alone or in combination with the principles from electricity and magnetism or atomic and nuclear physics. Such a question would not be classified uniquely according to any particular topic but would receive partial classifications by topics in proportion to the principles needed to arrive at the answers.

On both exams the multiple-choice section emphasizes the breadth of the students' knowledge and understanding of the basic principles of physics; the free-response section emphasizes the application of these principles in greater depth in solving more extended problems. In general, questions may ask students to:

- determine directions of vectors or paths of particles;
- draw or interpret diagrams;

- interpret or express physical relationships in graphical form;
- account for observed phenomena;
- interpret experimental data, including their limitations and uncertainties;
- construct and use conceptual models and explain their limitations;
- explain steps taken to arrive at a result or to predict future physical behavior;
- manipulate equations that describe physical relationships;
- obtain reasonable estimates; or
- solve problems that require the determination of physical quantities in either numerical or symbolic form and that may require the application of single or multiple physical concepts.

Laboratory-related questions may ask students to:

- design experiments, including identifying equipment needed and describing how it is to be used, drawing diagrams or providing descriptions of experimental setups, or describing procedures to be used, including controls and measurements to be taken;
- analyze data, including displaying data in graphical or tabular form, fitting lines and curves to data points in graphs, performing calculations with data, or making extrapolations and interpolations from data;
- analyze errors, including identifying sources of errors and how they propagate, estimating magnitude and direction of errors, determining significant digits, or identifying ways to reduce errors; or
- communicate results, including drawing inferences and conclusions from experimental data, suggesting ways to improve experiments, or proposing questions for further study.

The free-response section of each exam is printed in a separate booklet in which each part of a question is followed by a blank space for the student's solution. The same questions without the blank answer spaces are printed on green paper as an insert in the exam booklet. This green insert also contains a Table of Information and tables of commonly used equations. The Table of Information, which is also printed near the front of each multiple-choice section, includes numerical values of some physical constants and conversion factors and states some conventions used in the exams. The equation tables are described in greater detail in a later section. The green insert can be removed from the free-response answer booklet and used for reference when answering the free-response questions only.

The International System of Units (SI) is used predominantly in both exams. The use of rulers or straightedges is permitted on the free-response sections to facilitate the sketching of graphs or diagrams that might be required in these sections.

Since the complete exams are intended to provide the maximum information about differences in students' achievement in physics, students may find them more difficult

than many classroom exams. The best way for teachers to familiarize their students with the level of difficulty is to give them actual released exams (both multiple-choice and free-response sections) from past administrations. Information about ordering publications is on pages 58–61. Recent free-response sections can also be found on AP Central along with scoring guidelines and some sample student responses.

The Free-Response Sections—Student Presentation

Students are expected to show their work in the spaces provided for the solution for each part of a free-response question. If they need more space, they should clearly indicate where the work is continued or they may lose credit for it. If students make a mistake, they may cross it out or erase it. Crossed-out work and any work shown on the green insert will not be scored, and credit may be lost for incorrect work that is not crossed out.

In scoring the free-response sections, credit for the answers depends on the quality of the solutions and the explanations given; partial solutions may receive partial credit, so students are advised to show all their work. Correct answers without supporting work may lose credit. This is especially true when students are asked specifically to justify their answers, in which case the Exam Readers are looking for some verbal or mathematical analysis that shows how the students arrived at their answers. Also, all final numerical answers should include appropriate units.

On the AP Physics Exams the words “justify,” “explain,” “calculate,” “what is,” “determine,” “derive,” “sketch,” and “plot” have precise meanings. Students should pay careful attention to these words in order to obtain maximum credit and should avoid including irrelevant or extraneous material in their answers.

The ability to justify an answer in words shows understanding of the principles underlying physical phenomena in addition to the ability to perform the mathematical manipulations necessary to generate a correct answer. Students will be directed to justify or explain their answers on many of the questions they encounter on the AP Physics Exams. The words “justify” and “explain” indicate that the student should support the answer with prose, equations, calculations, diagrams, or graphs. The prose or equations may in some cases refer to fundamental ideas or relations in physics, such as Newton’s laws, conservation of energy, Gauss’s law, or Bernoulli’s equation. In other cases, the justification or explanation may take the form of analyzing the behavior of an equation for large or small values of a variable in the equation.

The words “calculate,” “what is,” “determine,” and “derive” have distinct meanings on the AP Physics Exams. “Calculate” means that a student is expected to show work leading to a final answer, which may be algebraic but more often is numerical. “What is” and “determine” indicate that work need not necessarily be explicitly shown to obtain full credit. Showing work leading to answers is a good idea, as it may earn a student partial credit in the case of an incorrect answer, but this step may be skipped by the confident or harried student. “Derive” is more specific and indicates that the students need to begin their solutions with one or more fundamental equations, such as those given on the AP Physics Exam equation sheet. The final answer, usually algebraic, is then obtained through the appropriate use of mathematics.

The words “sketch” and “plot” relate to student-produced graphs. “Sketch” means to draw a graph that illustrates key trends in a particular relationship, such as slope, curvature, intercept(s), or asymptote(s). Numerical scaling or specific data points are not required in a sketch. “Plot” means to draw the data points given in the problem on the grid provided, either using the given scale or indicating the scale and units when none are provided.

Additional information about study skills and test-taking strategies can be found at AP Central.

Calculators and Equation Tables

Policies regarding the use of calculators on the exams take into account the expansion of the capabilities of scientific calculators, which now include not only programming and graphing functions but also the availability of stored equations and other data. For taking the sections of the exams in which calculators are permitted, students should be allowed to use the calculators to which they are accustomed, except as noted below.* On the other hand, they should not have access to information in their calculators that is not available to other students, if that information is needed to answer the questions.

Calculators are NOT permitted on the multiple-choice sections of the **Physics B and Physics C exams.** The purpose of the multiple-choice sections is to assess the breadth of students’ knowledge and understanding of the basic concepts of physics. The multiple-choice questions emphasize conceptual understanding and qualitative applications. However, many physical definitions and principles are quantitative by nature and can therefore be expressed as equations. The knowledge of these basic definitions and principles, expressed as equations, is a part of the content of physics that should be learned by physics students and will continue to be assessed in the multiple-choice sections. However, any numeric calculations using these equations required in the multiple-choice sections will be kept simple. Also, in some questions, the answer choices differ by several orders of magnitude so that the questions can be answered by estimation. Students should be encouraged to develop their skills not only in estimating answers but also in recognizing answers that are physically unreasonable or unlikely.

Calculators are allowed on the free-response section of all exams. Any programmable or graphing calculator may be used except as noted below,* and students will not be required to erase their calculator memories before and after the exam. The free-response sections emphasize solving in-depth problems where knowledge of which principles to apply and how to apply them is the most important aspect of the solution to these problems.

Regardless of the type of calculator allowed, the exams are designed and scored to minimize the necessity of doing lengthy computations. When free-response problems

***Exceptions to calculator use.** Calculators that are not permitted are PowerBooks and portable/handheld computers; electronic writing pads or pen-input/stylus-driven devices (e.g., Palm, PDAs, Casio ClassPad 300); pocket organizers; models with QWERTY (i.e., typewriter) keypads (e.g., TI-92 Plus, Voyage 200); models with paper tapes; models that make noise or “talk”; models that require an electrical outlet; cell phone calculators. Students may not share calculators.

involve calculations, most of the points awarded in the grading of the solution are given for setting up the solution correctly rather than for actually carrying out the computation.

Tables containing commonly used physics equations are printed in the green insert provided with each exam for students to use when taking the free-response section. The equation tables may NOT be used when taking the multiple-choice section. The Table of Information and the equation tables for the 2008 and 2009 exams are included as an insert in this book so that they can easily be removed and duplicated for use by students. In general, the tables for each year's exam will be printed and distributed with the Course Description at least a year in advance so that students can become accustomed to using them throughout the year. However, since the equations will be provided with the exams, students are NOT allowed to bring their own copies to the exam room.

One of the purposes of providing the commonly used equations is to make the free-response sections equitable for those students who do not have access to equations stored in their calculators. The availability of these equations means that in the scoring of the free-response sections little or no credit will be awarded for simply writing down correct equations or for ambiguous answers unsupported by explanations or logical development.

The equations in the tables express relationships that are encountered most frequently in AP Physics courses and exams. However, they do not include all equations that might possibly be used. For example, they do not include many equations that can be derived by combining others in the tables. Nor do they include equations that are simply special cases of any that are in the tables. Students are responsible for understanding the physical principles that underlie each equation and for knowing the conditions for which each equation is applicable.

The equations are grouped in tables according to major content category. Within each table, the symbols used for the variables in that table are defined. However, in some cases the same symbol is used to represent different quantities in different tables. It should be noted that there is no uniform convention among textbooks for the symbols used in writing equations. The equation tables follow many common conventions, but in some cases consistency was sacrificed for the sake of clarity.

In summary, the purpose of minimizing numerical calculations in both sections of the exams and providing equations with the free-response sections is to place greater emphasis on the understanding and application of fundamental physical principles and concepts. For solving problems, a sophisticated programmable or graphing calculator, or the availability of stored equations, is no substitute for a thorough grasp of the physics involved.

Physics B: Sample Multiple-Choice Questions

Most of the following sample questions, illustrative of the Physics B Exam, have appeared in past exams. The answers are on page 28. Additional questions can be found in the *2004 AP Physics B and Physics C Released Exams* book.

Note: Units associated with numerical quantities are abbreviated, using the abbreviations listed in the table of information included with the exams (see insert in this book.) To simplify calculations, you may use $g = 10 \text{ m/s}^2$ in all problems.

Directions: Each of the questions or incomplete statements below is followed by five suggested answers or completions. Select the one that is best in each case.

- An object is thrown with a horizontal velocity of 20 m/s from a cliff that is 125 m above level ground. If air resistance is negligible, the time that it takes the object to fall to the ground from the cliff is most nearly
 - 3 s
 - 5 s
 - 6 s
 - 12 s
 - 25 s

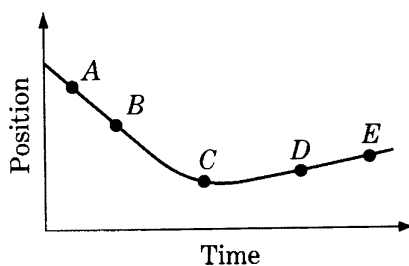

- The motion of a particle along a straight line is represented by the position versus time graph above. At which of the labeled points on the graph is the magnitude of the acceleration of the particle greatest?
 - A
 - B
 - C
 - D
 - E

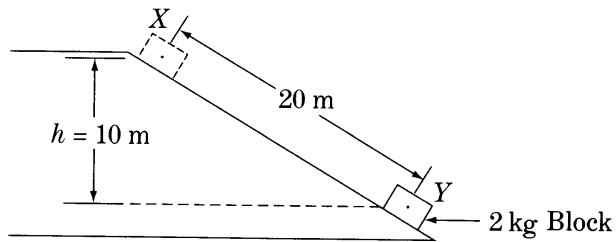
Questions 3–4

A 2 kg block, starting from rest, slides 20 m down a frictionless inclined plane from X to Y , dropping a vertical distance of 10 m as shown above.

3. The magnitude of the net force on the block while it is sliding is most nearly
 - (A) 0.1 N
 - (B) 0.4 N
 - (C) 2.5 N
 - (D) 5.0 N
 - (E) 10.0 N

4. The speed of the block at point Y is most nearly
 - (A) 7 m/s
 - (B) 10 m/s
 - (C) 14 m/s
 - (D) 20 m/s
 - (E) 100 m/s

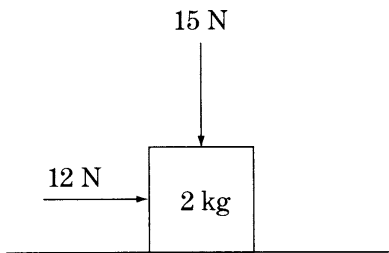

5. A block of mass 2 kg slides along a horizontal tabletop. A horizontal applied force of 12 N and a vertical applied force of 15 N act on the block, as shown above. If the coefficient of kinetic friction between the block and the table is 0.2, the frictional force exerted on the block is most nearly
- (A) 1 N
 - (B) 3 N
 - (C) 4 N
 - (D) 5 N
 - (E) 7 N

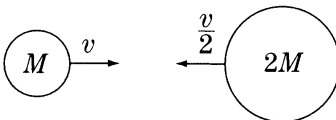

6. A ball of mass M and speed v collides head-on with a ball of mass $2M$ and speed $\frac{v}{2}$, as shown above. If the two balls stick together, their speed after the collision is
- (A) 0
 - (B) $\frac{v}{2}$
 - (C) $\frac{\sqrt{2}v}{2}$
 - (D) $\frac{\sqrt{3}v}{2}$
 - (E) $\frac{3v}{2}$

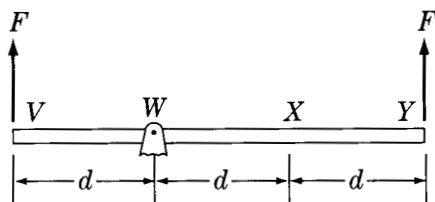

7. A massless rigid rod of length $3d$ is pivoted at a fixed point W , and two forces each of magnitude F are applied vertically upward as shown above. A third vertical force of magnitude F may be applied, either upward or downward, at one of the labeled points. With the proper choice of direction at each point, the rod can be in equilibrium if the third force of magnitude F is applied at point
- (A) W only
 - (B) Y only
 - (C) V or X only
 - (D) V or Y only
 - (E) V , W , or X
8. An ideal monatomic gas is compressed while its temperature is held constant. What happens to the internal energy of the gas during this process, and why?
- (A) It decreases because the gas does work on its surroundings.
 - (B) It decreases because the molecules of an ideal gas collide.
 - (C) It does not change because the internal energy of an ideal gas depends only on its temperature.
 - (D) It increases because work is done on the gas.
 - (E) It increases because the molecules travel a shorter path between collisions.

Sample Questions for **Physics B**

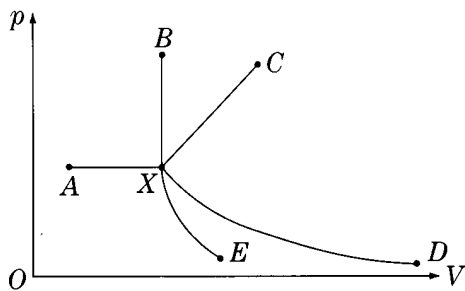

9. In the pV diagram above, the initial state of a gas is shown at point X . Which of the curves represents a process in which no work is done on or by the gas?
- (A) XA
 - (B) XB
 - (C) XC
 - (D) XD
 - (E) XE

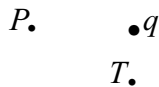

10. An isolated positive charge q is in the plane of the page, as shown above. The directions of the electric field vectors at points P and T , which are also in the plane of the page, are given by which of the following?

| <u>Point P</u> | <u>Point T</u> |
|-----------------------------|-------------------------------|
| (A) Left | Right |
| (B) Right | Left |
| (C) Left | Toward the top of the page |
| (D) Right | Toward the top of the page |
| (E) Left | Toward the bottom of the page |

Questions 11–12 relate to the following circuit in which the battery has zero internal resistance.

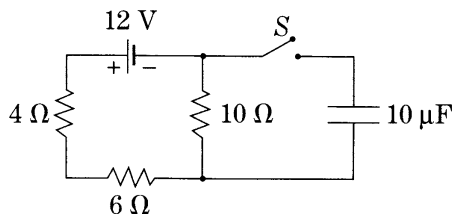

11. What is the current in the $4\ \Omega$ resistor while the switch S is open?
- (A) 0 A
 (B) 0.6 A
 (C) 1.2 A
 (D) 2.0 A
 (E) 3.0 A
12. When the switch S is closed and the $10\ \mu\text{F}$ capacitor is fully charged, what is the voltage across the capacitor?
- (A) 0 V
 (B) 6 V
 (C) 12 V
 (D) 60 V
 (E) 120 V

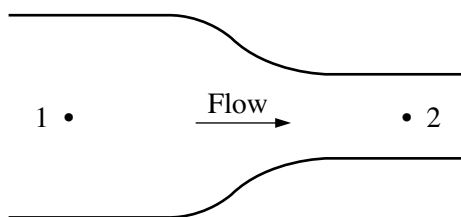

13. A fluid flows steadily from left to right in the pipe shown above. The diameter of the pipe is less at point 2 than at point 1, and the fluid density is constant throughout the pipe. How do the velocity of flow and the pressure at points 1 and 2 compare?

| | <u>Velocity</u> | <u>Pressure</u> |
|-----|-----------------|-----------------|
| (A) | $v_1 < v_2$ | $p_1 = p_2$ |
| (B) | $v_1 < v_2$ | $p_1 > p_2$ |
| (C) | $v_1 = v_2$ | $p_1 < p_2$ |
| (D) | $v_1 > v_2$ | $p_1 = p_2$ |
| (E) | $v_1 > v_2$ | $p_1 > p_2$ |

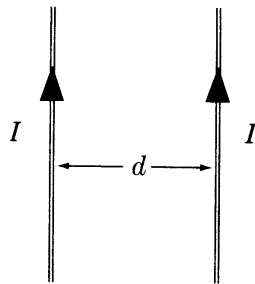

14. Two long parallel wires, separated by a distance d , carry equal currents I toward the top of the page, as shown above. The magnetic field due to the wires at a point halfway between them is

- (A) zero in magnitude
- (B) directed into the page
- (C) directed out of the page
- (D) directed to the right
- (E) directed to the left

15. A source S of sound and a listener L each can be at rest or can move directly toward or away from each other with speed v_0 . In which of the following situations will the observer hear the lowest frequency of sound from the source?

- (A) $\begin{array}{cc} S & L \\ \bullet & \bullet \\ v=0 & v=0 \end{array}$
- (B) $\begin{array}{cc} S & L \\ \bullet & \bullet \longrightarrow \\ v=0 & v=v_0 \end{array}$
- (C) $\begin{array}{cc} S & L \\ \bullet & \bullet \\ \longleftarrow v=v_0 & v=0 \end{array}$
- (D) $\begin{array}{cc} S & L \\ \bullet & \bullet \\ \longleftarrow v=v_0 & \bullet \longrightarrow \\ v=v_0 & v=v_0 \end{array}$
- (E) $\begin{array}{cc} S & L \\ \bullet \longrightarrow & \bullet \longleftarrow \\ v=v_0 & v=v_0 \end{array}$

16. The wavelength of yellow sodium light in vacuum is 5.89×10^{-7} m. The speed of this light in glass with an index of refraction of 1.5 is most nearly

- (A) 4×10^{-7} m/s
- (B) 9×10^{-7} m/s
- (C) 2×10^8 m/s
- (D) 3×10^8 m/s
- (E) 4×10^8 m/s

17. An object O is in front of a convex mirror. The focal point of the mirror is labeled F and the center of curvature is labeled C . The direction of the reflected ray is correctly illustrated in all of the following EXCEPT which diagram?

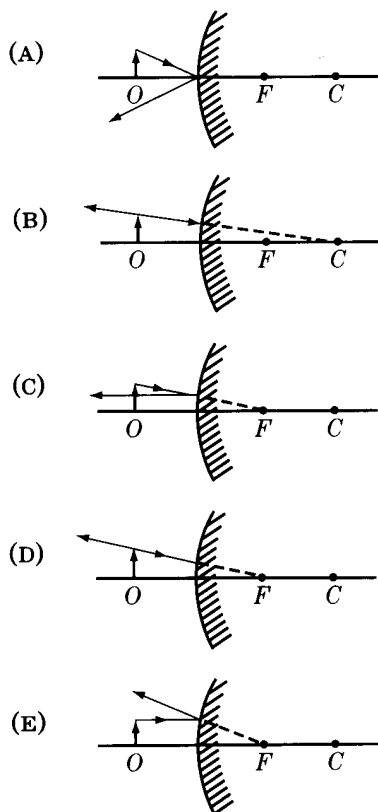

18. A system initially consists of an electron and an incident photon. The electron and the photon collide, and afterward the system consists of the electron and a scattered photon. The electron gains kinetic energy as a result of this collision. Compared with the incident photon, the scattered photon has
- (A) the same energy
 - (B) a smaller speed
 - (C) a larger speed
 - (D) a smaller frequency
 - (E) a larger frequency

19. In an experiment, light of a particular wavelength is incident on a metal surface, and electrons are emitted from the surface as a result. To produce more electrons per unit time but with less kinetic energy per electron, the experimenter should do which of the following?
- (A) Increase the intensity and decrease the wavelength of the light.
 - (B) Increase the intensity and the wavelength of the light.
 - (C) Decrease the intensity and the wavelength of the light.
 - (D) Decrease the intensity and increase the wavelength of the light.
 - (E) None of the above would produce the desired result.
20. When ^{10}B is bombarded by neutrons, a neutron can be absorbed and an alpha particle (^4He) emitted. The kinetic energy of the reaction products is equal to the
- (A) kinetic energy of the incident neutron
 - (B) total energy of the incident neutron
 - (C) energy equivalent of the mass decrease in the reaction
 - (D) energy equivalent of the mass decrease in the reaction, minus the kinetic energy of the incident neutron
 - (E) energy equivalent of the mass decrease in the reaction, plus the kinetic energy of the incident neutron

Answers to Physics B Multiple-Choice Questions

| | | | | |
|-------|-------|--------|--------|--------|
| 1 – B | 5 – E | 9 – B | 13 – B | 17 – D |
| 2 – C | 6 – A | 10 – E | 14 – A | 18 – D |
| 3 – E | 7 – C | 11 – B | 15 – D | 19 – B |
| 4 – C | 8 – C | 12 – B | 16 – C | 20 – E |

Physics B: Sample Free-Response Questions

The following six questions constituted the complete free-response section of the 2006 AP Physics B Exam. All free-response questions released since 1999 can be found at AP Central.

Directions: Answer all six questions, which are weighted according to the points indicated. The suggested times are about 17 minutes for answering each of Questions 1–4 and about 11 minutes for answering each of Questions 5–6. The parts within a question may not have equal weight. Show all your work in the pink booklet in the spaces provided after each part, NOT in this green insert.

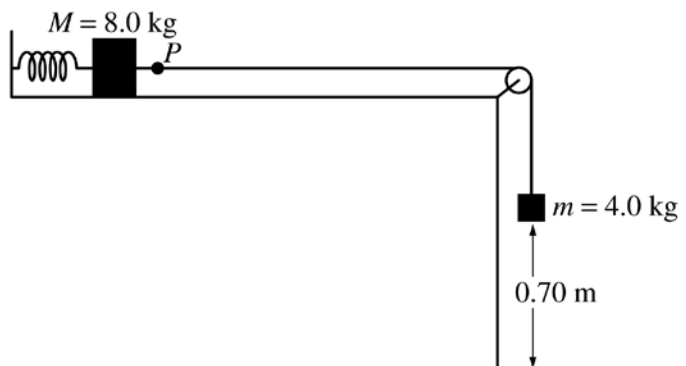

1. (15 points)

An ideal spring of unstretched length 0.20 m is placed horizontally on a frictionless table as shown above. One end of the spring is fixed and the other end is attached to a block of mass $M = 8.0$ kg. The 8.0 kg block is also attached to a massless string that passes over a small frictionless pulley. A block of mass $m = 4.0$ kg hangs from the other end of the string. When this spring-and-blocks system is in equilibrium, the length of the spring is 0.25 m and the 4.0 kg block is 0.70 m above the floor.

- (a) On the figures below, draw free-body diagrams showing and labeling the forces on each block when the system is in equilibrium.

$M = 8.0$ kg

$m = 4.0$ kg



- (b) Calculate the tension in the string.
 (c) Calculate the force constant of the spring.

The string is now cut at point P .

- (d) Calculate the time taken by the 4.0 kg block to hit the floor.
 (e) Calculate the frequency of oscillation of the 8.0 kg block.
 (f) Calculate the maximum speed attained by the 8.0 kg block.

2. (15 points)

A world-class runner can complete a 100 m dash in about 10 s. Past studies have shown that runners in such a race accelerate uniformly for a time t_u and then run at constant speed for the remainder of the race. A world-class runner is visiting your physics class. You are to develop a procedure that will allow you to determine the uniform acceleration a_u and an approximate value of t_u for the runner in a 100 m dash. By necessity your experiment will be done on a straight track and include your whole class of eleven students.

- (a) By checking the line next to each appropriate item in the list below, select the equipment, other than the runner and the track, that your class will need to do the experiment.

Stopwatches Tape measures Rulers
 Masking tape Metersticks Starter's pistol
 String Chalk

- (b) Outline the procedure that you would use to determine a_u and t_u , including a labeled diagram of the experimental setup. Use symbols to identify carefully what measurements you would make and include in your procedure how you would use each piece of the equipment you checked in part (a).
- (c) Outline the process of data analysis, including how you will identify the portion of the race that has uniform acceleration, and how you would calculate the uniform acceleration.

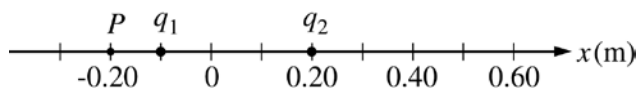

3. (15 points)

Two point charges, q_1 and q_2 , are placed 0.30 m apart on the x -axis, as shown in the figure above. Charge q_1 has a value of -3.0×10^{-9} C. The net electric field at point P is zero.

- (a) What is the sign of charge q_2 ?

Positive Negative

Justify your answer.

- (b) Calculate the magnitude of charge q_2 .
- (c) Calculate the magnitude of the electric force on q_2 and indicate its direction.
- (d) Determine the x -coordinate of the point on the line between the two charges at which the electric potential is zero.
- (e) How much work must be done by an external force to bring an electron from infinity to the point at which the electric potential is zero? Explain your reasoning.

4. (15 points)

A student performs an experiment to determine the index of refraction n of a rectangular glass slab in air. She is asked to use a laser beam to measure angles of incidence θ_i in air and corresponding angles of refraction θ_r in glass. The measurements of the angles for five trials are given in the table below.

| Trial | θ_i | θ_r | | |
|-------|------------|------------|--|--|
| 1 | 30° | 20° | | |
| 2 | 40° | 27° | | |
| 3 | 50° | 32° | | |
| 4 | 60° | 37° | | |
| 5 | 70° | 40° | | |

- (a) Complete the last two columns in the table by calculating the quantities that need to be graphed to provide a linear relationship from which the index of refraction can be determined. Label the top of each column.
- (b) On the grid below, plot the quantities calculated in (a) and draw an appropriate graph from which the index of refraction can be determined. Label the axes.

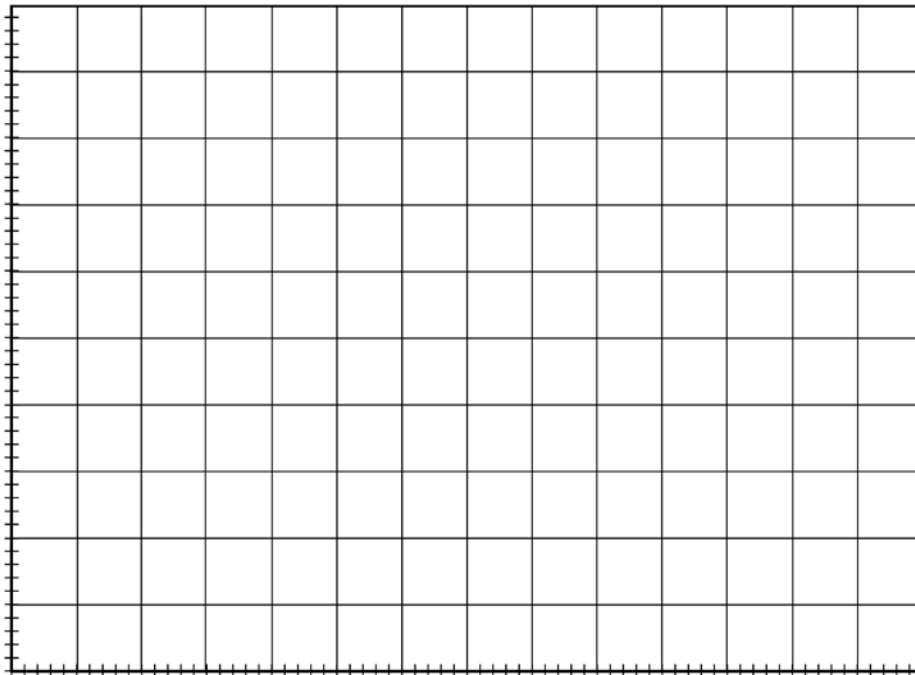

- (c) Using the graph, calculate the index of refraction of the glass slab.

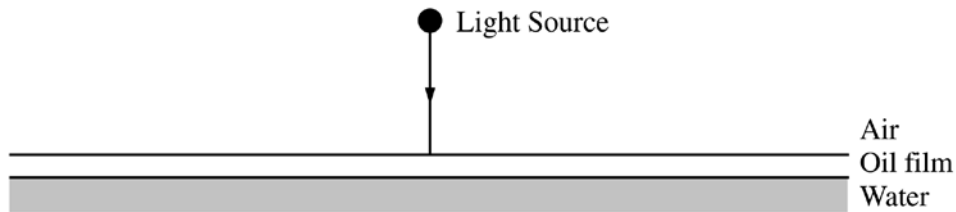

The student is also asked to determine the thickness of a film of oil ($n = 1.43$) on the surface of water ($n = 1.33$). Light from a variable wavelength source is incident vertically onto the oil film as shown above. The student measures a maximum in the intensity of the reflected light when the incident light has a wavelength of 600 nm.

- (d) At which of the two interfaces does the light undergo a 180° phase change on reflection?
- The air-oil interface only The oil-water interface only
 Both interfaces Neither interface
- (e) Calculate the minimum possible thickness of the oil film.

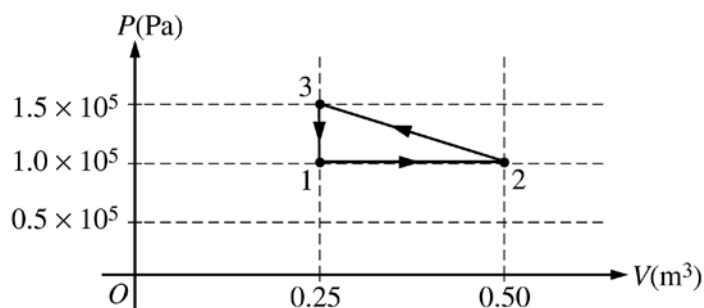

5. (10 points)

A cylinder with a movable frictionless piston contains an ideal gas that is initially in state 1 at 1×10^5 Pa, 373 K, and 0.25 m^3 . The gas is taken through a reversible thermodynamic cycle as shown in the PV diagram above.

(a) Calculate the temperature of the gas when it is in the following states.

- i. State 2
- ii. State 3

(b) Calculate the net work done on the gas during the cycle.

(c) Was heat added to or removed from the gas during the cycle?

___ Added ___ Removed ___ Neither added nor removed

Justify your answer.

6. (10 points)

A photon with a wavelength of $1.5 \times 10^{-8} \text{ m}$ is emitted from an ultraviolet source into a vacuum.

- (a) Calculate the energy of the photon.
- (b) Calculate the de Broglie wavelength of an electron with kinetic energy equal to the energy of the photon.
- (c) Describe an experiment that illustrates the wave properties of this electron.

Physics C Mechanics: Sample Multiple-Choice Questions

Most of the following sample questions have appeared in past exams. The answers are on page 38. Additional questions can be found in the 2004 *AP Physics B and Physics C Released Exams* book.

Note: Units associated with numerical quantities are abbreviated, using the abbreviations listed in the table of information included with the exams (see insert in this book). To simplify calculations, you may use $g = 10 \text{ m/s}^2$ in all problems.

Directions: Each of the questions or incomplete statements below is followed by five suggested answers or completions. Select the one that is best in each case.

Questions 1–2

The speed v of an automobile moving on a straight road is given in meters per second as a function of time t in seconds by the following equation:

$$v = 4 + 2t^3$$

1. What is the acceleration of the automobile at $t = 2 \text{ s}$?
 - (A) 12 m/s^2
 - (B) 16 m/s^2
 - (C) 20 m/s^2
 - (D) 24 m/s^2
 - (E) 28 m/s^2
2. How far has the automobile traveled in the interval between $t = 0$ and $t = 2 \text{ s}$?
 - (A) 16 m
 - (B) 20 m
 - (C) 24 m
 - (D) 32 m
 - (E) 72 m

3. If a particle moves in a plane so that its position is described by the functions $x = A \cos \omega t$ and $y = A \sin \omega t$, the particle is
- (A) moving with constant speed along a circle
 - (B) moving with varying speed along a circle
 - (C) moving with constant acceleration along a straight line
 - (D) moving along a parabola
 - (E) oscillating back and forth along a straight line

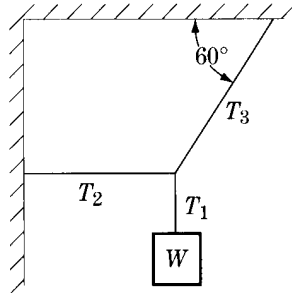

4. A system in equilibrium consists of an object of weight W that hangs from three ropes, as shown above. The tensions in the ropes are T_1 , T_2 , and T_3 . Which of the following are correct values of T_2 and T_3 ?

- | $\frac{T_2}{T_3}$ | $\frac{T_3}{T_2}$ |
|-------------------------------|---------------------------|
| (A) $W \tan 60^\circ$ | $\frac{W}{\cos 60^\circ}$ |
| (B) $W \tan 60^\circ$ | $\frac{W}{\sin 60^\circ}$ |
| (C) $W \tan 60^\circ$ | $W \sin 60^\circ$ |
| (D) $\frac{W}{\tan 60^\circ}$ | $\frac{W}{\cos 60^\circ}$ |
| (E) $\frac{W}{\tan 60^\circ}$ | $\frac{W}{\sin 60^\circ}$ |

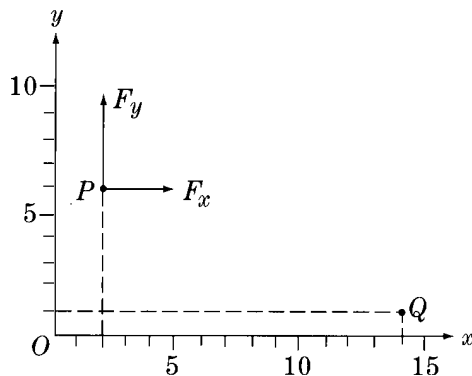

5. The constant force \mathbf{F} with components $F_x = 3 \text{ N}$ and $F_y = 4 \text{ N}$, shown above, acts on a body while that body moves from the point P ($x = 2 \text{ m}$, $y = 6 \text{ m}$) to the point Q ($x = 14 \text{ m}$, $y = 1 \text{ m}$). How much work does the force do on the body during this process?
- (A) 16 J
 (B) 30 J
 (C) 46 J
 (D) 56 J
 (E) 65 J
6. The sum of all the external forces on a system of particles is zero. Which of the following must be true of the system?
- (A) The total mechanical energy is constant.
 (B) The total potential energy is constant.
 (C) The total kinetic energy is constant.
 (D) The total linear momentum is constant.
 (E) It is in static equilibrium.

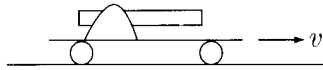

7. A toy cannon is fixed to a small cart and both move to the right with speed v along a straight track, as shown above. The cannon points in the direction of motion. When the cannon fires a projectile the cart and cannon are brought to rest. If M is the mass of the cart and cannon combined without the projectile, and m is the mass of the projectile, what is the speed of the projectile relative to the ground immediately after it is fired?

- (A) $\frac{Mv}{m}$
 (B) $\frac{(M + m)v}{m}$
 (C) $\frac{(M + m)v}{m}$
 (D) $\frac{mv}{M}$
 (E) $\frac{mv}{(M - m)}$

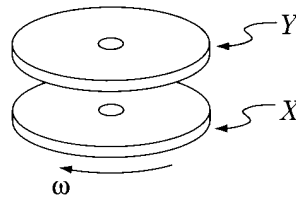

8. A disk X rotates freely with angular velocity ω on frictionless bearings, as shown above. A second identical disk Y , initially not rotating, is placed on X so that both disks rotate together without slipping. When the disks are rotating together, which of the following is half what it was before?
- (A) Moment of inertia of X
 (B) Moment of inertia of Y
 (C) Angular velocity of X
 (D) Angular velocity of Y
 (E) Angular momentum of both disks

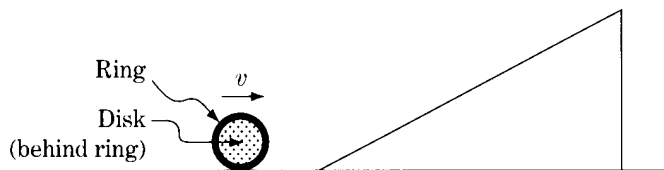

9. The ring and the disk shown above have identical masses, radii, and velocities, and are not attached to each other. If the ring and the disk each roll without slipping up an inclined plane, how will the distances that they move up the plane before coming to rest compare?
- (A) The ring will move farther than will the disk.
 (B) The disk will move farther than will the ring.
 (C) The ring and the disk will move equal distances.
 (D) The relative distances depend on the angle of elevation of the plane.
 (E) The relative distances depend on the length of the plane.
10. Let g be the acceleration due to gravity at the surface of a planet of radius R . Which of the following is a dimensionally correct formula for the minimum kinetic energy K that a projectile of mass m must have at the planet's surface if the projectile is to escape from the planet's gravitational field?
- (A) $K = \sqrt{gR}$
 (B) $K = mgR$
 (C) $K = \frac{mg}{R}$
 (D) $K = m\sqrt{\frac{g}{R}}$
 (E) $K = gR$

Answers to Physics C Mechanics Multiple-Choice Questions

| | | | | |
|-------|-------|-------|-------|--------|
| 1 – D | 3 – A | 5 – A | 7 – B | 9 – A |
| 2 – A | 4 – E | 6 – D | 8 – C | 10 – B |

Physics C Mechanics: Sample Free-Response Questions

The following three questions constituted the complete free-response section of the 2006 AP Physics C Mechanics Exam. All free-response questions released since 1999 can be found at AP Central.

Directions: Answer all three questions. The suggested time is about 15 minutes for answering each of the questions, which are worth 15 points each. The parts within a question may not have equal weight. Show all your work in the pink booklet in the spaces provided after each part, NOT in this green insert.

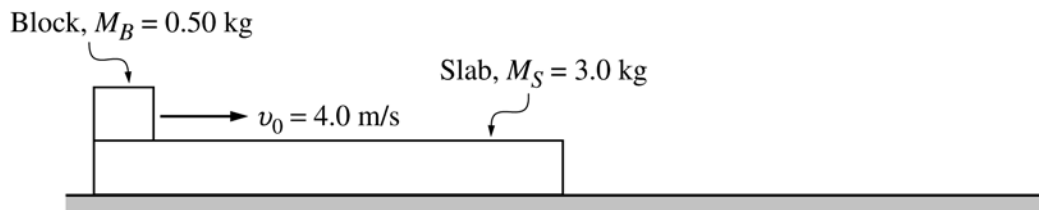

Mech 1.

A small block of mass $M_B = 0.50$ kg is placed on a long slab of mass $M_S = 3.0$ kg as shown above. Initially, the slab is at rest and the block has a speed v_0 of 4.0 m/s to the right. The coefficient of kinetic friction between the block and the slab is 0.20, and there is no friction between the slab and the horizontal surface on which it moves.

- (a) On the dots below that represent the block and the slab, draw and label vectors to represent the forces acting on each as the block slides on the slab.

Block

Slab



At some moment later, before the block reaches the right end of the slab, both the block and the slab attain identical speeds v_f .

- (b) Calculate v_f .
- (c) Calculate the distance the slab has traveled at the moment it reaches v_f .
- (d) Calculate the work done by friction on the slab from the beginning of its motion until it reaches v_f .

Mech 2.

A nonlinear spring is compressed various distances x , and the force F required to compress it is measured for each distance. The data are shown in the table below.

| x (m) | F (N) | |
|---------|---------|--|
| 0.05 | 4 | |
| 0.10 | 17 | |
| 0.15 | 38 | |
| 0.20 | 68 | |
| 0.25 | 106 | |

Assume that the magnitude of the force applied by the spring is of the form $F(x) = Ax^2$.

- Which quantities should be graphed in order to yield a straight line whose slope could be used to calculate a numerical value for A ?
- Calculate values for any of the quantities identified in (a) that are not given in the data, and record these values in the table above. Label the top of the column, including units.
- On the axes below, plot the quantities you indicated in (a) . Label the axes with the variables and appropriate numbers to indicate the scale.

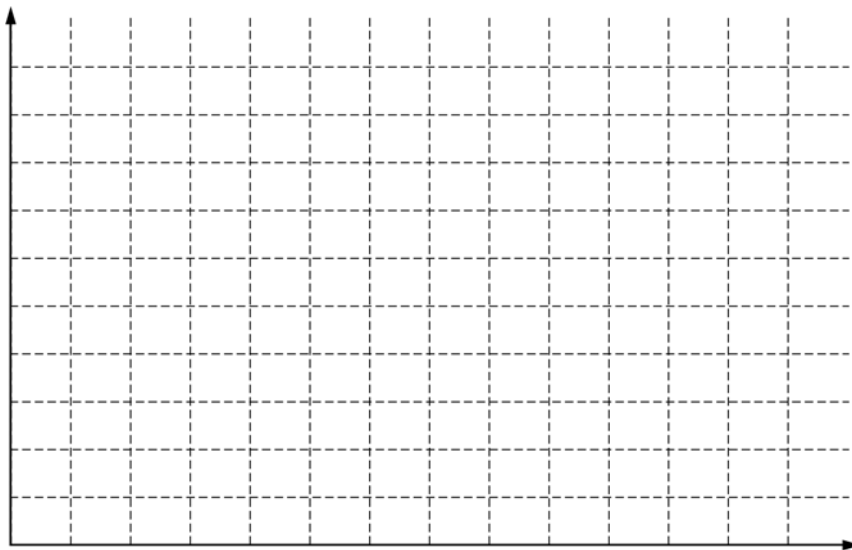

- Using your graph, calculate A .

The spring is then placed horizontally on the floor. One end of the spring is fixed to a wall. A cart of mass 0.50 kg moves on the floor with negligible friction and collides head-on with the free end of the spring, compressing it a maximum distance of 0.10 m.

- Calculate the work done by the cart in compressing the spring 0.10 m from its equilibrium length.
- Calculate the speed of the cart just before it strikes the spring.

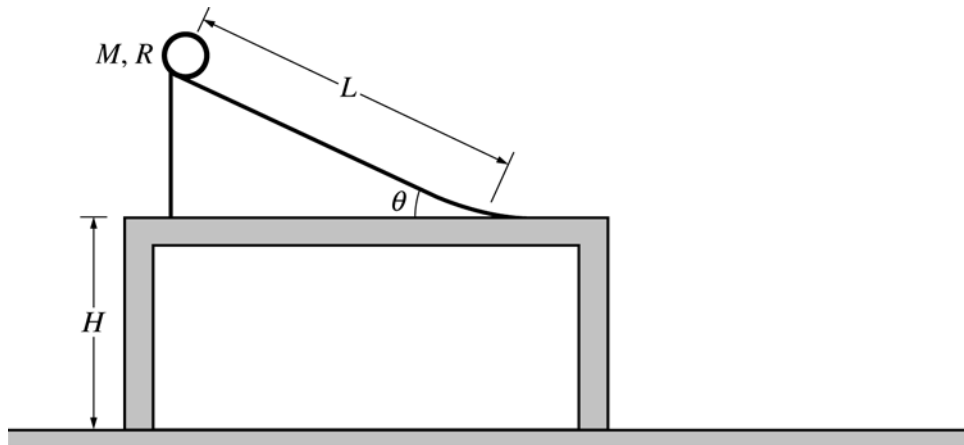

Mech 3.

A thin hoop of mass M , radius R , and rotational inertia MR^2 is released from rest from the top of the ramp of length L above. The ramp makes an angle θ with respect to a horizontal tabletop to which the ramp is fixed. The table is a height H above the floor. Assume that the hoop rolls without slipping down the ramp and across the table. Express all algebraic answers in terms of given quantities and fundamental constants.

- Derive an expression for the acceleration of the center of mass of the hoop as it rolls down the ramp.
- Derive an expression for the speed of the center of mass of the hoop when it reaches the bottom of the ramp.
- Derive an expression for the horizontal distance from the edge of the table to where the hoop lands on the floor.
- Suppose that the hoop is now replaced by a disk having the same mass M and radius R . How will the distance from the edge of the table to where the disk lands on the floor compare with the distance determined in part (c) for the hoop?

_____ Less than _____ The same as _____ Greater than

Briefly justify your response.

Physics C Electricity and Magnetism: Sample Multiple-Choice Questions

Most of the following sample questions have appeared in past exams. The answers are on page 48. Additional questions can be found in the *2004 AP Physics B and Physics C Released Exams* book.

Note: Units associated with numerical quantities are abbreviated, using the abbreviations listed in the table of information included with the exams (see insert in this book.)

Directions: Each of the questions or incomplete statements below is followed by five suggested answers or completions. Select the one that is best in each case.

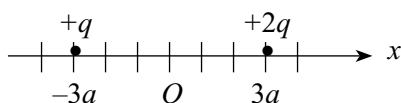

- Two charges are located on the x -axis of a coordinate system as shown above. The charge $+2q$ is located at $x = +3a$ and the charge $+q$ is located at $x = -3a$. Where on the x -axis should an additional charge $+4q$ be located to produce an electric field equal to zero at the origin O ?
 - $x = -6a$
 - $x = -2a$
 - $x = +a$
 - $x = +2a$
 - $x = +6a$

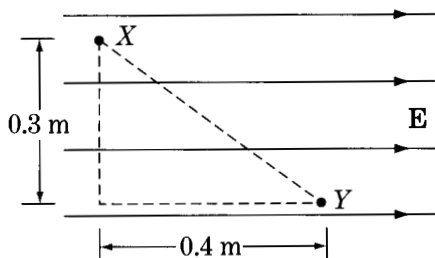

- A uniform electric field \mathbf{E} of magnitude $6,000\text{ V/m}$ exists in a region of space as shown above. What is the electric potential difference, $V_X - V_Y$, between points X and Y ?
 - $-12,000\text{ V}$
 - 0 V
 - $1,800\text{ V}$
 - $2,400\text{ V}$
 - $3,000\text{ V}$

3. Charge is distributed uniformly throughout a long nonconducting cylinder of radius R . Which of the following graphs best represents the magnitude of the resulting electric field E as a function of r , the distance from the axis of the cylinder?

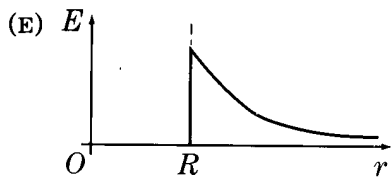
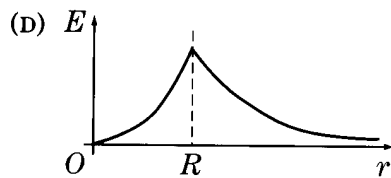
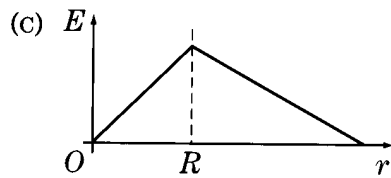
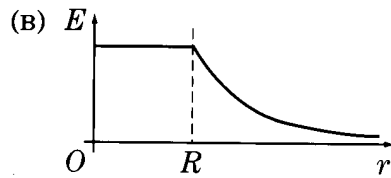
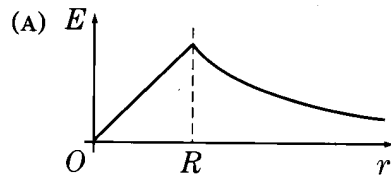

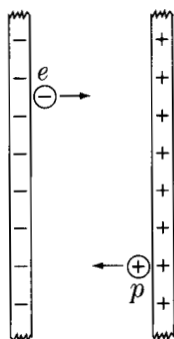

4. A proton p and an electron e are released simultaneously on opposite sides of an evacuated area between large, charged parallel plates, as shown above. Each particle is accelerated toward the oppositely charged plate. The particles are far enough apart so that they do not affect each other. Which particle has the greater kinetic energy upon reaching the oppositely charged plate?
- (A) The electron
 (B) The proton
 (C) Neither particle; both kinetic energies are the same.
 (D) It cannot be determined without knowing the value of the potential difference between the plates.
 (E) It cannot be determined without knowing the amount of charge on the plates.

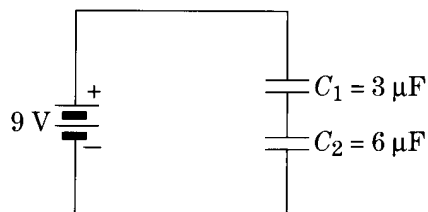

5. Two capacitors initially uncharged are connected in series to a battery, as shown above. What is the charge on the top plate of C_1 ?
- (A) $-81 \mu\text{C}$
 (B) $-18 \mu\text{C}$
 (C) $0 \mu\text{C}$
 (D) $+18 \mu\text{C}$
 (E) $+81 \mu\text{C}$

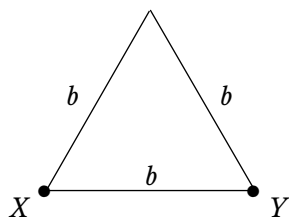

6. Wire of resistivity ρ and cross-sectional area A is formed into an equilateral triangle of side b , as shown above. The resistance between two vertices of the triangle, X and Y , is
- (A) $\frac{3}{2} \frac{A}{\rho b}$
- (B) $3 \frac{A}{\rho b}$
- (C) $\frac{2}{3} \frac{\rho b}{A}$
- (D) $\frac{3}{2} \frac{\rho b}{A}$
- (E) $3 \frac{\rho b}{A}$

Questions 7–8

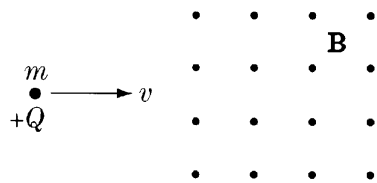

A particle of electric charge $+Q$ and mass m initially moves along a straight line in the plane of the page with constant speed v , as shown above. The particle enters a uniform magnetic field of magnitude B directed out of the page and moves in a semicircular arc of radius R .

7. Which of the following best indicates the magnitude and the direction of the magnetic force \mathbf{F} on the charge just after the charge enters the magnetic field?

| <u>Magnitude</u> | <u>Direction</u> |
|------------------------|-------------------------------|
| (A) $\frac{kQ^2}{R^2}$ | Toward the top of the page |
| (B) $\frac{kQ^2}{R^2}$ | Toward the bottom of the page |
| (C) QvB | Out of the plane of the page |
| (D) QvB | Toward the top of the page |
| (E) QvB | Toward the bottom of the page |

8. If the magnetic field strength is increased, which of the following will be true about the radius R ?

- I. R increases if the incident speed is held constant.
- II. For R to remain constant, the incident speed must be increased.
- III. For R to remain constant, the incident speed must be decreased.

- (A) I only
- (B) II only
- (C) III only
- (D) I and II only
- (E) I and III only

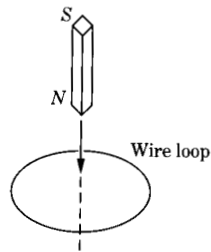

9. A bar magnet is lowered at constant speed through a loop of wire as shown in the diagram above. The time at which the midpoint of the bar magnet passes through the loop is t_1 . Which of the following graphs best represents the time dependence of the induced current in the loop? (A positive current represents a counterclockwise current in the loop as viewed from above.)

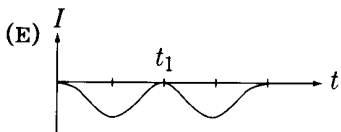
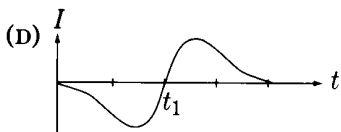
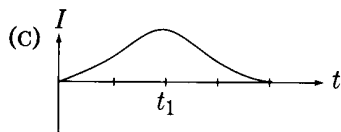
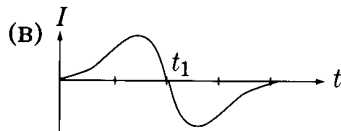
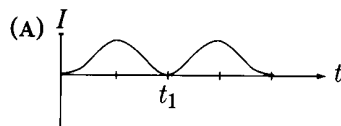

10. A loop of wire enclosing an area of 1.5 m^2 is placed perpendicular to a magnetic field. The field is given in teslas as a function of time t in seconds by

$$B(t) = \frac{20t}{3} - 5$$

The induced emf in the loop at $t = 3 \text{ s}$ is most nearly

- (A) 0 V
- (B) 5 V
- (C) 10 V
- (D) 15 V
- (E) 20 V

**Answers to Physics C Electricity and Magnetism
Multiple-Choice Questions**

| | | | | |
|-------|-------|-------|-------|--------|
| 1 – A | 3 – A | 5 – D | 7 – E | 9 – B |
| 2 – D | 4 – C | 6 – C | 8 – B | 10 – C |

Physics C Electricity and Magnetism: Sample Free-Response Questions

The following three questions constituted the complete free-response section of the 2006 AP Physics C Electricity and Magnetism Exam. All free-response questions released since 1999 can be found at AP Central.

Directions: Answer all three questions. The suggested time is about 15 minutes for answering each of the questions, which are worth 15 points each. The parts within a question may not have equal weight. Show all your work in the pink booklet in the spaces provided after each part, NOT in this green insert.

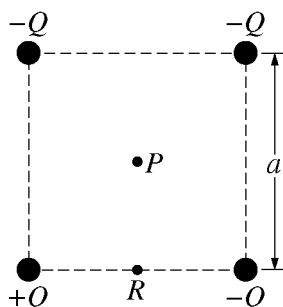

E&M 1.

The square of side a above contains a positive point charge $+Q$ fixed at the lower left corner and negative point charges $-Q$ fixed at the other three corners of the square. Point P is located at the center of the square.

- On the diagram, indicate with an arrow the direction of the net electric field at point P .
- Derive expressions for each of the following in terms of the given quantities and fundamental constants.
 - The magnitude of the electric field at point P
 - The electric potential at point P
- A positive charge is placed at point P . It is then moved from point P to point R , which is at the midpoint of the bottom side of the square. As the charge is moved, is the work done on it by the electric field positive, negative, or zero?

_____ Positive _____ Negative _____ Zero

Explain your reasoning.

- Describe one way to replace a single charge in this configuration that would make the electric field at the center of the square equal to zero. Justify your answer.
 - Describe one way to replace a single charge in this configuration such that the electric potential at the center of the square is zero but the electric field is not zero. Justify your answer.

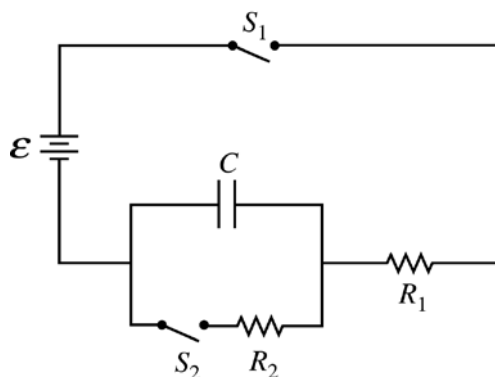

E&M 2.

The circuit above contains a capacitor of capacitance C , a power supply of emf \mathcal{E} , two resistors of resistances R_1 and R_2 , and two switches, S_1 and S_2 . Initially, the capacitor is uncharged and both switches are open. Switch S_1 then gets closed at time $t = 0$.

- Write a differential equation that can be solved to obtain the charge on the capacitor as a function of time t .
- Solve the differential equation in part (a) to determine the charge on the capacitor as a function of time t .

Numerical values for the components are given as follows:

$$\begin{aligned}\mathcal{E} &= 12 \text{ V} \\ C &= 0.060 \text{ F} \\ R_1 = R_2 &= 4700 \text{ } \Omega\end{aligned}$$

- Determine the time at which the capacitor has a voltage 4.0 V across it.

After switch S_1 has been closed for a long time, switch S_2 gets closed at a new time $t = 0$.

- On the axes below, sketch graphs of the current I_1 in R_1 versus time and of the current I_2 in R_2 versus time, beginning when switch S_2 is closed at new time $t = 0$. Clearly label which graph is I_1 and which is I_2 .



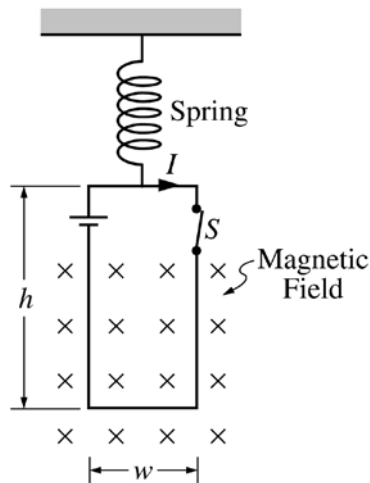

E&M 3.

A loop of wire of width w and height h contains a switch and a battery and is connected to a spring of force constant k , as shown above. The loop carries a current I in a clockwise direction, and its bottom is in a constant, uniform magnetic field directed into the plane of the page.

- (a) On the diagram of the loop below, indicate the directions of the magnetic forces, if any, that act on each side of the loop.



- (b) The switch S is opened, and the loop eventually comes to rest at a new equilibrium position that is a distance x from its former position. Derive an expression for the magnitude B_0 of the uniform magnetic field in terms of the given quantities and fundamental constants.

The spring and loop are replaced with a loop of the same dimensions and resistance R but without the battery and switch. The new loop is pulled upward, out of the magnetic field, at constant speed v_0 . Express algebraic answers to the following questions in terms of B_0 , v_0 , R , and the dimensions of the loop.

(c)

- i. On the diagram of the new loop below, indicate the direction of the induced current in the loop as the loop moves upward.

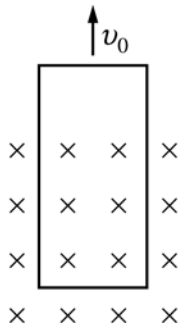

- ii. Derive an expression for the magnitude of this current.
- (d) Derive an expression for the power dissipated in the loop as the loop is pulled at constant speed out of the field.
- (e) Suppose the magnitude of the magnetic field is increased. Does the external force required to pull the loop at speed v_0 increase, decrease, or remain the same?

_____ Increases _____ Decreases _____ Remains the same

Justify your answer.

AP[®] Program Essentials

The AP Reading

Each year in June, the free-response section of the exams, as well as the AP Studio Art portfolios, are scored by college faculty and secondary school AP teachers at the AP Reading. Thousands of Readers participate, under the direction of a Chief Reader (a college professor) in each AP subject. The experience offers both significant professional development and the opportunity to network with like-minded educators.

If you are an AP teacher or a college faculty member and would like to serve as a Reader, you can apply online at apcentral.collegeboard.com/readers. Alternatively, you can send an e-mail to apreader@ets.org or call Performance Assessment Scoring Services at 609 406-5384.

AP Grades

The Readers' scores on the essay and problem-solving questions are combined with the results of the computer-scored multiple-choice questions, and the total raw scores are converted to a composite score on AP's 5-point scale:

| AP GRADE | QUALIFICATION |
|----------|--------------------------|
| 5 | Extremely well qualified |
| 4 | Well qualified |
| 3 | Qualified |
| 2 | Possibly qualified |
| 1 | No recommendation |

Grade Distributions

Many teachers want to compare their students' grades with national percentiles. Grade distribution charts are available at AP Central, as is information on how the grade boundaries for each AP grade are established. Grade distribution charts are also available on the AP student site at www.collegeboard.com/apstudents.

Why Colleges Grant Credit, Placement, or Both for AP Grades

Colleges know that the AP grades of incoming students represent a level of achievement equivalent to that of students who take the same course in the colleges' own classrooms. That equivalency is ensured through several AP Program processes:

- College faculty serve on the committees that develop the Course Descriptions and exams in each AP course.
- College faculty are responsible for standard setting and are involved in the evaluation of student responses at the AP Reading.
- AP courses and exams are reviewed and updated regularly based on the results of curriculum surveys at up to 200 colleges and universities, collaborations among the College Board and key educational and disciplinary organizations, and the interactions of committee members with professional organizations in their discipline.

- Periodic college comparability studies are undertaken in which the performance of college students on AP Exams is compared with that of AP students to confirm that the AP grade scale of 1 to 5 is properly aligned with current college standards.

In addition, the College Board has commissioned studies that use a “bottom-line” approach to validating AP Exam grades by comparing the achievement of AP students with non-AP students in higher level college courses. For example, in the 1998 Morgan and Ramist “21-College” study, AP students who were exempted from introductory courses and who completed a higher level course in college compared favorably, on the basis of their college grades, with students who completed the prerequisite first course in college, then took the second, higher level course in the subject area. Such studies answer the question of greatest concern to colleges: Are AP students who are exempted from introductory courses as well prepared to continue in a subject area as students who took their first course in college? To see the results of several college validity studies, visit apcentral.collegeboard.com/colleges/research. (The complete Morgan and Ramist study can be downloaded from the site.)

Guidelines on Setting Credit and Placement Policies for AP Grades

The College Board has created two useful resources for admissions administrators and academic faculty who need guidance on setting an AP policy for their college or university. The printed guide *AP and Higher Education* provides guidance for colleges and universities in setting AP credit and placement policies. The booklet details how to set an AP policy, summarizes AP research studies, and describes in detail course and exam development and the exam scoring process. AP Central has a section geared toward colleges and universities that provides similar information and additional resources, including links to all AP research studies, Released Exam questions, and sample student responses at varying levels of achievement for each AP Exam. Visit apcentral.collegeboard.com/highered.

The *Advanced Placement Policy Guide* for each AP subject is designed for college faculty responsible for setting their department’s AP policy. These folios provide content specific to each AP Exam, including validity research studies and a description of the AP course curriculum. Ordering information for these and other publications can be found in the AP Publications and Other Resources section of this Course Description.

College and University AP Credit and Placement Policies

Each college and university sets its own AP credit and placement policies. The AP Program has created an online search tool, AP Credit Policy Info, that provides links to credit and placement policies at hundreds of colleges and universities. The tool helps students find the credit hours and advanced placement they can receive for qualifying exam scores within each AP subject. AP Credit Policy Info is available at www.collegeboard.com/ap/creditpolicy.

AP Scholar Awards

The AP Program offers a number of AP Scholar Awards to recognize high school students who have demonstrated college-level achievement through consistently high performance on AP Exams. Although there is no monetary award, students receive an award certificate, and the achievement is acknowledged on grade reports sent to colleges following the announcement of the awards. For detailed information about AP Scholar Awards (including qualification criteria), visit AP Central or contact the College Board's national office. Students can find this information at www.collegeboard.com/apstudents.

AP Calendar

The *AP Program Guide* for education professionals and the *Bulletin for AP Students and Parents* provide important Program information and details on the key events in the AP calendar. Information on ordering or downloading these publications can be found at the back of this book.

Exam Security

All parts of every AP Exam must be kept secure at all times. Forty-eight hours after the exam has been administered, the inserts containing the free-response questions (Section II) can be made available for teacher and student review.* **However, the multiple-choice section (Section I) must remain secure both before and after the exam administration.** No one other than students taking the exam can ever have access to or see the questions contained in Section I—this includes AP Coordinators and all teachers. The multiple-choice section must never be shared, copied in any manner, or reconstructed by teachers and students after the exam. **Schools that knowingly or unknowingly violate these policies will not be permitted to administer AP Exams in the future and may be held responsible for any damages or losses the College Board and/or ETS incur in the event of a security breach.**

Selected multiple-choice questions are reused from year to year to provide an essential method of establishing high exam reliability, controlled levels of difficulty, and comparability with earlier exams. These goals can be attained only when the multiple-choice questions remain secure. This is why teachers cannot view the questions, and students cannot share information about these questions with anyone following the exam administration.

To ensure that all students have an equal opportunity to demonstrate their abilities on the exam, AP Exams must be administered in a uniform manner. **It is extremely important to follow the administration schedule and all procedures outlined in detail in the most recent *AP Coordinator's Manual*.** Please note that AP Studio Art portfolios and their contents are not considered secure testing materials; see the *AP Coordinator's Manual* and the appropriate *AP Examination Instructions* book for further information. The *Manual* also includes directions on how to handle misconduct and other security problems. All schools participating in AP automatically

*The free-response section of the alternate form (used for late testing administration) is NOT released.

receive printed copies of the *Manual*. It is also available in PDF format at apcentral.collegeboard.com/coordinators. Any breach of security should be reported to the Office of Testing Integrity immediately (call 800 353-8570 or 609 406-5427, fax 609 406-9709, or e-mail tsreturns@ets.org).

Teacher Support

AP Central® (apcentral.collegeboard.com)

You can find the following Web resources at AP Central (free registration required):

- AP Course Descriptions, AP Exam questions and scoring guidelines, sample syllabi, research reports, and feature articles.
- A searchable Institutes and Workshops database, providing information about professional development events. AP Central offers online events that participants can access from their home or school computers.
- The Course Home Pages (apcentral.collegeboard.com/coursehomepages), which contain insightful articles, teaching tips, activities, lab ideas, and other course-specific content contributed by colleagues in the AP community.
- In-depth FAQs, including brief responses to frequently asked questions about AP courses and exams, the AP Program, and other topics of interest.
- Links to AP publications and products (some available for immediate download) that can be purchased online at the College Board Store (store.collegeboard.com).
- Moderated electronic discussion groups (EDGs) for each AP course to facilitate the exchange of ideas and practices.
- Teachers' Resources database—click on the “Teachers' Resources” tab to search for reviews of textbooks, reference books, documents, Web sites, software, videos, and more. College and high school faculty write the reviews with specific reference to the value of the resources in teaching AP courses.

Online Workshops and Events

College Board online events and workshops are designed to help support and expand the high level of professional development currently offered to teachers in Pre-AP and AP workshops and AP Summer Institutes. Because of budgetary, geographical, and time constraints, not all teachers and administrators are able to take advantage of live, face-to-face workshops. The College Board develops and offers both standard and customized online events and workshops for schools, districts, and states in both live and recorded formats. Online events and workshops are developed and presented by experienced College Board consultants and college faculty. Full-day online workshops are equivalent to one-day, face-to-face workshops and participants can earn CEU credits. For more information, visit apcentral.collegeboard.com/onlineevents.

Pre-AP[®]

Pre-AP[®] is a suite of K–12 professional development resources and services designed to help equip middle school and high school teachers with the strategies and tools they need to engage their students in high-level learning, thereby ensuring that every middle school and high school student has the opportunity to acquire a deep understanding of the skills, habits of mind, and concepts they need to succeed in college.

Pre-AP is based on the following premises. The first is the expectation that all students can perform at rigorous academic levels. This expectation should be reflected in the curriculum and instruction throughout the school so that all students are consistently being challenged to bring their knowledge and skills to the next level.

The second important premise of Pre-AP is the belief that educators can prepare every student for higher intellectual engagement by starting the development of skills and the acquisition of knowledge as early as possible. When addressed effectively, the middle school and high school years can provide a powerful opportunity to help all students acquire the knowledge, concepts, and skills needed to engage in a higher level of learning.

Pre-AP teacher professional development explicitly supports the goal of college as an option for every student. It is important to have a recognized standard for college-level academic work. The AP Program provides these standards for Pre-AP. Pre-AP professional development resources reflect the topics, concepts, and skills taught in AP courses and assessed in AP Exams.

The College Board does not design, develop, or assess courses or examinations labeled “Pre-AP.” The College Board discourages the labeling of courses as “Pre-AP.” Typically, such courses create a track, thereby limiting access to AP classes. The College Board supports the assertion that all students should have access to preparation for AP and other challenging courses. Courses labeled “Pre-AP” can inappropriately restrict access to AP and other college-level work and, as such, are inconsistent with the fundamental purpose of the College Board’s Pre-AP initiatives.

Pre-AP Professional Development

Pre-AP professional development is available through workshops and conferences coordinated by the College Board’s regional offices. Pre-AP professional development is divided into three categories:

1. **Vertical Teaming**—Articulation of content and pedagogy across the middle school and high school years. The emphasis is on aligning curricula and improving teacher communication. The intended outcome is a coordinated program of teaching skills and concepts over several years.
2. **Classroom Strategies**—Content-specific classroom strategies for middle school and high school teachers. Various approaches, techniques, and ideas are emphasized.

- 3. Instructional Leadership**—Administrators and other instructional leaders examine how to use Pre-AP professional development—especially AP Vertical Teams®—to create a system that challenges all students to perform at rigorous academic levels.

For a complete list of Pre-AP professional development offerings, please contact your regional office or visit apcentral.collegeboard.com/pre-ap.

AP Publications and Other Resources

A number of AP resources are available to help students, parents, AP Coordinators, and high school and college faculty learn more about the AP Program and its courses and exams. To identify resources that may be of particular use to you, refer to the following key.

| | |
|---|-----------|
| AP Coordinators and Administrators | A |
| College Faculty | C |
| Students and Parents | SP |
| Teachers | T |

Free Resources

Copies of the following items can be ordered free of charge at apcentral.collegeboard.com/freepubs. Items marked with a computer mouse icon  can be downloaded for free from AP Central.

 **The Value of AP Courses and Exams** **A, SP, T**

This brochure, available in English and Spanish, can be used by school counselors and administrators to provide parents and students with information about the many benefits of participation in AP courses and exams.

AP Tools for Schools Resource Kit **A**

This complimentary resource assists schools in building their AP programs. The kit includes the video *Experience College Success*, the brochure *The Value of AP Courses and Exams*, and brief descriptions of the AP Credit Policy Info search tool and the Parent's Night *PowerPoint* presentation.

Experience College Success is a six-minute video that provides a short overview of the AP Program, with commentary from admissions officers, college students, and high school faculty about the benefits of participation in AP courses. Each videotape includes both an English and Spanish version.

 **Bulletin for AP Students and Parents** **SP**

This bulletin provides a general description of the AP Program, including information on the policies and procedures related to taking the exams. It describes each AP Exam, lists the advantages of taking the exams, describes the grade reporting process, and includes the upcoming exam schedule. The *Bulletin* is available in both English and Spanish.

 **Get with the Program** **SP**

All students, especially those from underserved backgrounds, should understand the value of a high-quality education. Written especially for students and their families, this bilingual (Spanish/English) brochure highlights the benefits of participation in the AP Program. (The brochure can be ordered in large quantities for students in grades 8–12.)

 **AP Program Guide** **A**

This guide takes the AP Coordinator through the school year step-by-step—organizing an AP program, ordering and administering the AP Exams, AP Exam payment, and grade reporting. It also includes information on teacher professional development, AP resources, and exam schedules.

 **AP and Higher Education** **A, C, T**

This publication is intended to inform and help educational professionals at the secondary and postsecondary levels understand the benefits of having a coherent, equitable AP credit and placement policy. Topics included are development of AP courses and exams, grading of AP Exams, exam validation, research studies comparing the performance of AP students with non-AP students, uses of AP Exams by students in college, and how faculty can get involved in the AP Program.

 **Advanced Placement Policy Guides** **A, C, T**

These policy guides are designed for college faculty responsible for setting their department's AP policy, and provide, in a subject-specific context, information about AP validity studies, college faculty involvement, and AP course curricular content. There are separate guides for each AP subject field.

Priced Publications

The following items can be ordered through the College Board Store at store.collegeboard.com. Alternatively, you can download an AP Order Form from AP Central at apcentral.collegeboard.com/documentlibrary.

 **Course Descriptions** **A, C, SP, T**

Course Descriptions are available for each AP subject. They provide an outline of each AP course's content, explain the kinds of skills students are expected to demonstrate in the corresponding introductory college-level course, and describe the AP Exam. Sample multiple-choice questions with an answer key and sample free-response questions are included.

Note: PDF versions of current AP Course Descriptions for each AP subject may be downloaded free of charge from AP Central and the College Board's Web site for students. Follow the above instructions to purchase printed copies. (The Course Description for AP Computer Science is available in electronic format only.)

Released Exams

C, T

Periodically the AP Program releases a complete copy of each exam. In addition to providing the multiple-choice questions and answers, the publication describes the process of scoring the free-response questions and includes examples of students' actual responses, the scoring standards, and commentary that explains why the responses received the scores they did.

Teacher's Guides

T

For those about to teach an AP course for the first time, or for experienced AP teachers who would like to get some fresh ideas for the classroom, the *Teacher's Guide* is an excellent resource. Each *Teacher's Guide* contains syllabi developed by high school teachers currently teaching the AP course and college faculty who teach the equivalent course at colleges and universities. Along with detailed course outlines and innovative teaching tips, you'll also find extensive lists of suggested teaching resources.

AP Vertical Team Guides

A, T

AP Vertical Teams (APVT) are made up of teachers from different grade levels who work together to develop and implement a sequential curriculum in a given discipline. Teams help students acquire the skills necessary for success in AP courses. To assist teachers and administrators who are interested in establishing an APVT at their school, the College Board has published these guides: *AP Vertical Teams Guide for English*; *AP Vertical Teams Guide for Mathematics and Statistics*; *AP Vertical Teams Guide for Science*; *AP Vertical Teams Guide for Social Studies*; *AP Vertical Teams Guide for World Languages and Cultures*; *AP Vertical Teams Guide for Fine Arts, Vol. 1: Studio Art*; *AP Vertical Teams Guide for Fine Arts, Vol. 2: Music Theory*; and *AP Vertical Teams Guide for Fine Arts, Vols. 1 and 2 (set)*.

Multimedia

APCD® (home version), (multinetwork site license)

SP, T

These CD-ROMs are available for AP Calculus AB, AP English Literature, AP European History, and AP U.S. History. They each include actual AP Exams, interactive tutorials, exam descriptions, answers to frequently asked questions, and test-taking strategies. Also included are a listing of resources for further study and a planner to help students schedule and organize their study time.

The teacher version of each CD, which can be licensed for up to 50 workstations, enables you to monitor student progress and provide individual feedback. Included is a Teacher's Manual that gives full explanations along with suggestions for utilizing the APCD in the classroom.

Electronic Publications

Additional supplemental publications are available in electronic format to be purchased and downloaded from the College Board Store. These include a collection of 13 AP World History Teaching Units, AP Calculus free-response questions and solutions from 1969 to 1997, and the *Physics Lab Guide*.

Announcements of new electronic publications can be found on the AP Course Home Pages on AP Central (apcentral.collegeboard.com/coursehomepages).



Table of Information and Equation Tables for AP[®] Physics Exams

The accompanying Table of Information and Equation Tables will be provided to students when they take the AP Physics Exams. Therefore, students may NOT bring their own copies of these tables to the exam room, although they may use them throughout the year in their classes in order to become familiar with their content.

Table of Information

For both the Physics B and Physics C Exams, the Table of Information is printed near the front cover of the multiple-choice section and on the green insert provided with the free-response section. The tables are identical for both exams except for one convention as noted.

Equation Tables

For both the Physics B and Physics C Exams, the equation tables for each exam are printed only on the green insert provided with the free-response section. The equation tables may be used by students when taking the free-response sections of both exams but NOT when taking the multiple-choice sections.

The equations in the tables express the relationships that are encountered most frequently in AP Physics courses and exams. However, the tables do not include all equations that might possibly be used. For example, they do not include many equations that can be derived by combining other equations in the tables. Nor do they include equations that are simply special cases of any that are in the tables. Students are responsible for understanding the physical principles that underlie each equation and for knowing the conditions for which each equation is applicable.

The equation tables are grouped in sections according to the major content category in which they appear. Within each section, the symbols used for the variables in that section are defined. However, in some cases the same symbol is used to represent different quantities in different tables. It should be noted that there is no uniform convention among textbooks for the symbols used in writing equations. The equation tables follow many common conventions, but in some cases consistency was sacrificed for the sake of clarity.

Some explanations about notation used in the equation tables:

1. The symbols used for physical constants are the same as those in the Table of Information and are defined in the Table of Information rather than in the right-hand columns of the tables.
2. Symbols in bold face represent vector quantities.
3. Subscripts on symbols in the equations are used to represent special cases of the variables defined in the right-hand columns.
4. The symbol Δ before a variable in an equation specifically indicates a change in the variable (i.e., final value minus initial value).
5. Several different symbols (e.g., d , r , s , h , ℓ) are used for linear dimensions such as length. The particular symbol used in an equation is one that is commonly used for that equation in textbooks.

TABLE OF INFORMATION FOR 2008 and 2009

| CONSTANTS AND CONVERSION FACTORS | |
|---|--|
| Proton mass, $m_p = 1.67 \times 10^{-27}$ kg | Electron charge magnitude, $e = 1.60 \times 10^{-19}$ C |
| Neutron mass, $m_n = 1.67 \times 10^{-27}$ kg | 1 electron volt, $1 \text{ eV} = 1.60 \times 10^{-19}$ J |
| Electron mass, $m_e = 9.11 \times 10^{-31}$ kg | Speed of light, $c = 3.00 \times 10^8$ m/s |
| Avogadro's number, $N_0 = 6.02 \times 10^{23}$ mol ⁻¹ | Universal gravitational constant, $G = 6.67 \times 10^{-11}$ m ³ /kg·s ² |
| Universal gas constant, $R = 8.31$ J/(mol·K) | Acceleration due to gravity at Earth's surface, $g = 9.8$ m/s ² |
| Boltzmann's constant, $k_B = 1.38 \times 10^{-23}$ J/K | |
| 1 unified atomic mass unit, | $1 \text{ u} = 1.66 \times 10^{-27}$ kg = 931 MeV/c ² |
| Planck's constant, | $h = 6.63 \times 10^{-34}$ J·s = 4.14 × 10 ⁻¹⁵ eV·s |
| | $hc = 1.99 \times 10^{-25}$ J·m = 1.24 × 10 ³ eV·nm |
| Vacuum permittivity, | $\epsilon_0 = 8.85 \times 10^{-12}$ C ² /N·m ² |
| Coulomb's law constant, $k = 1/4\pi\epsilon_0 = 9.0 \times 10^9$ N·m ² /C ² | |
| Vacuum permeability, | $\mu_0 = 4\pi \times 10^{-7}$ (T·m)/A |
| Magnetic constant, $k' = \mu_0/4\pi = 10^{-7}$ (T·m)/A | |
| 1 atmosphere pressure, | $1 \text{ atm} = 1.0 \times 10^5$ N/m ² = 1.0 × 10 ⁵ Pa |

| | | | | | | | | |
|-----------------|-----------|----|---------|-----|----------|---|-----------------|----|
| UNIT SYMBOLS | meter, | m | mole, | mol | watt, | W | farad, | F |
| | kilogram, | kg | hertz, | Hz | coulomb, | C | tesla, | T |
| | second, | s | newton, | N | volt, | V | degree Celsius, | °C |
| | ampere, | A | pascal, | Pa | ohm, | Ω | electron-volt, | eV |
| | kelvin, | K | joule, | J | henry, | H | | |

| PREFIXES | | |
|-------------------|--------|--------|
| Factor | Prefix | Symbol |
| 10 ⁹ | giga | G |
| 10 ⁶ | mega | M |
| 10 ³ | kilo | k |
| 10 ⁻² | centi | c |
| 10 ⁻³ | milli | m |
| 10 ⁻⁶ | micro | μ |
| 10 ⁻⁹ | nano | n |
| 10 ⁻¹² | pico | p |

| VALUES OF TRIGONOMETRIC FUNCTIONS FOR COMMON ANGLES | | | | | | | |
|---|----|--------------|-----|--------------|-----|--------------|-----|
| θ | 0° | 30° | 37° | 45° | 53° | 60° | 90° |
| $\sin \theta$ | 0 | 1/2 | 3/5 | $\sqrt{2}/2$ | 4/5 | $\sqrt{3}/2$ | 1 |
| $\cos \theta$ | 1 | $\sqrt{3}/2$ | 4/5 | $\sqrt{2}/2$ | 3/5 | 1/2 | 0 |
| $\tan \theta$ | 0 | $\sqrt{3}/3$ | 3/4 | 1 | 4/3 | $\sqrt{3}$ | ∞ |

The following conventions are used in this exam.

- I. Unless otherwise stated, the frame of reference of any problem is assumed to be inertial.
- II. The direction of any electric current is the direction of flow of positive charge (conventional current).
- III. For any isolated electric charge, the electric potential is defined as zero at an infinite distance from the charge.
- *IV. For mechanics and thermodynamics equations, W represents the work done on a system.

*Not on the Table of Information for Physics C, since Thermodynamics is not a Physics C topic.

ADVANCED PLACEMENT PHYSICS B EQUATIONS FOR 2008 and 2009

NEWTONIAN MECHANICS

| | |
|--|---------------------------------|
| $v = v_0 + at$ | $a =$ acceleration |
| | $F =$ force |
| $x = x_0 + v_0t + \frac{1}{2}at^2$ | $f =$ frequency |
| | $h =$ height |
| $v^2 = v_0^2 + 2a(x - x_0)$ | $J =$ impulse |
| $\Sigma \mathbf{F} = \mathbf{F}_{net} = m\mathbf{a}$ | $K =$ kinetic energy |
| | $k =$ spring constant |
| $F_{fric} \leq \mu N$ | $\ell =$ length |
| | $m =$ mass |
| $a_c = \frac{v^2}{r}$ | $N =$ normal force |
| | $P =$ power |
| $\tau = rF \sin \theta$ | $p =$ momentum |
| | $r =$ radius or distance |
| $\mathbf{p} = m\mathbf{v}$ | $T =$ period |
| $\mathbf{J} = \mathbf{F}\Delta t = \Delta\mathbf{p}$ | $t =$ time |
| | $U =$ potential energy |
| $K = \frac{1}{2}mv^2$ | $v =$ velocity or speed |
| | $W =$ work done on a system |
| $\Delta U_g = mgh$ | $x =$ position |
| | $\mu =$ coefficient of friction |
| $W = F\Delta r \cos \theta$ | $\theta =$ angle |
| | $\tau =$ torque |
| $P_{avg} = \frac{W}{\Delta t}$ | |
| $P = Fv \cos \theta$ | |
| $\mathbf{F}_s = -k\mathbf{x}$ | |
| $U_s = \frac{1}{2}kx^2$ | |
| $T_s = 2\pi\sqrt{\frac{m}{k}}$ | |
| $T_p = 2\pi\sqrt{\frac{\ell}{g}}$ | |
| $T = \frac{1}{f}$ | |
| $F_G = -\frac{Gm_1m_2}{r^2}$ | |
| $U_G = -\frac{Gm_1m_2}{r}$ | |

ELECTRICITY AND MAGNETISM

| | |
|--|--|
| $F = \frac{1}{4\pi\epsilon_0} \frac{q_1q_2}{r^2}$ | $A =$ area |
| | $B =$ magnetic field |
| $\mathbf{E} = \frac{\mathbf{F}}{q}$ | $C =$ capacitance |
| | $d =$ distance |
| $U_E = qV = \frac{1}{4\pi\epsilon_0} \frac{q_1q_2}{r}$ | $E =$ electric field |
| | $\mathcal{E} =$ emf |
| $E_{avg} = -\frac{V}{d}$ | $F =$ force |
| | $I =$ current |
| $V = \frac{1}{4\pi\epsilon_0} \sum_i \frac{q_i}{r_i}$ | $\ell =$ length |
| $C = \frac{Q}{V}$ | $P =$ power |
| | $Q =$ charge |
| $C = \frac{\epsilon_0 A}{d}$ | $q =$ point charge |
| | $R =$ resistance |
| $U_c = \frac{1}{2}QV = \frac{1}{2}CV^2$ | $r =$ distance |
| | $t =$ time |
| $I_{avg} = \frac{\Delta Q}{\Delta t}$ | $U =$ potential (stored) energy |
| | $V =$ electric potential or potential difference |
| $R = \frac{\rho\ell}{A}$ | $v =$ velocity or speed |
| $V = IR$ | $\rho =$ resistivity |
| $P = IV$ | $\theta =$ angle |
| $C_p = \sum_i C_i$ | $\phi_m =$ magnetic flux |
| $\frac{1}{C_s} = \sum_i \frac{1}{C_i}$ | |
| $R_s = \sum_i R_i$ | |
| $\frac{1}{R_p} = \sum_i \frac{1}{R_i}$ | |
| $F_B = qvB \sin \theta$ | |
| $F_B = BIl \sin \theta$ | |
| $B = \frac{\mu_0 I}{2\pi r}$ | |
| $\phi_m = BA \cos \theta$ | |
| $\mathcal{E}_{avg} = -\frac{\Delta\phi_m}{\Delta t}$ | |
| $\mathcal{E} = B\ell v$ | |

ADVANCED PLACEMENT PHYSICS B EQUATIONS FOR 2008 and 2009

FLUID MECHANICS AND THERMAL PHYSICS

| | |
|---|--|
| $P = P_0 + \rho gh$ | $A = \text{area}$ |
| $F_{\text{buoy}} = \rho Vg$ | $e = \text{efficiency}$ |
| $A_1v_1 = A_2v_2$ | $F = \text{force}$ |
| $P + \rho gy + \frac{1}{2}\rho v^2 = \text{const.}$ | $h = \text{depth}$ |
| $\Delta\ell = \alpha\ell_0\Delta T$ | $H = \text{rate of heat transfer}$ |
| $H = \frac{kA\Delta T}{L}$ | $k = \text{thermal conductivity}$ |
| $P = \frac{F}{A}$ | $K_{\text{avg}} = \text{average molecular kinetic energy}$ |
| $PV = nRT = Nk_B T$ | $\ell = \text{length}$ |
| $K_{\text{avg}} = \frac{3}{2}k_B T$ | $L = \text{thickness}$ |
| $v_{\text{rms}} = \sqrt{\frac{3RT}{M}} = \sqrt{\frac{3k_B T}{\mu}}$ | $M = \text{molar mass}$ |
| $W = -P\Delta V$ | $n = \text{number of moles}$ |
| $\Delta U = Q + W$ | $N = \text{number of molecules}$ |
| $e = \left \frac{W}{Q_H} \right $ | $P = \text{pressure}$ |
| $e_c = \frac{T_H - T_C}{T_H}$ | $Q = \text{heat transferred to a system}$ |
| | $T = \text{temperature}$ |
| | $U = \text{internal energy}$ |
| | $V = \text{volume}$ |
| | $v = \text{velocity or speed}$ |
| | $v_{\text{rms}} = \text{root-mean-square velocity}$ |
| | $W = \text{work done on a system}$ |
| | $y = \text{height}$ |
| | $\alpha = \text{coefficient of linear expansion}$ |
| | $\mu = \text{mass of molecule}$ |
| | $\rho = \text{density}$ |

ATOMIC AND NUCLEAR PHYSICS

| | |
|------------------------------|-------------------------------|
| $E = hf = pc$ | $E = \text{energy}$ |
| $K_{\text{max}} = hf - \phi$ | $f = \text{frequency}$ |
| $\lambda = \frac{h}{p}$ | $K = \text{kinetic energy}$ |
| $\Delta E = (\Delta m)c^2$ | $m = \text{mass}$ |
| | $p = \text{momentum}$ |
| | $\lambda = \text{wavelength}$ |
| | $\phi = \text{work function}$ |

WAVES AND OPTICS

| | |
|---|--|
| $v = f\lambda$ | $d = \text{separation}$ |
| $n = \frac{c}{v}$ | $f = \text{frequency or focal length}$ |
| $n_1 \sin \theta_1 = n_2 \sin \theta_2$ | $h = \text{height}$ |
| $\sin \theta_c = \frac{n_2}{n_1}$ | $L = \text{distance}$ |
| $\frac{1}{s_i} + \frac{1}{s_o} = \frac{1}{f}$ | $M = \text{magnification}$ |
| $M = \frac{h_i}{h_o} = -\frac{s_i}{s_o}$ | $m = \text{an integer}$ |
| $f = \frac{R}{2}$ | $n = \text{index of refraction}$ |
| $d \sin \theta = m\lambda$ | $R = \text{radius of curvature}$ |
| $x_m \approx \frac{m\lambda L}{d}$ | $s = \text{distance}$ |
| | $v = \text{speed}$ |
| | $x = \text{position}$ |
| | $\lambda = \text{wavelength}$ |
| | $\theta = \text{angle}$ |

GEOMETRY AND TRIGONOMETRY

| | |
|---------------------|----------------------------|
| Rectangle | $A = \text{area}$ |
| $A = bh$ | $C = \text{circumference}$ |
| Triangle | $V = \text{volume}$ |
| $A = \frac{1}{2}bh$ | $S = \text{surface area}$ |
| Circle | $b = \text{base}$ |
| $A = \pi r^2$ | $h = \text{height}$ |
| $C = 2\pi r$ | $\ell = \text{length}$ |
| Parallelepiped | $w = \text{width}$ |
| $V = \ell wh$ | $r = \text{radius}$ |

Cylinder

$$V = \pi r^2 \ell$$

$$S = 2\pi r \ell + 2\pi r^2$$

Sphere

$$V = \frac{4}{3}\pi r^3$$

$$S = 4\pi r^2$$

Right Triangle

$$a^2 + b^2 = c^2$$

$$\sin \theta = \frac{a}{c}$$

$$\cos \theta = \frac{b}{c}$$

$$\tan \theta = \frac{a}{b}$$

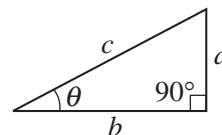

ADVANCED PLACEMENT PHYSICS C EQUATIONS FOR 2008 and 2009

MECHANICS

| | |
|---|--|
| $v = v_0 + at$ | $a = \text{acceleration}$ |
| $x = x_0 + v_0t + \frac{1}{2}at^2$ | $F = \text{force}$ |
| $v^2 = v_0^2 + 2a(x - x_0)$ | $f = \text{frequency}$ |
| $\Sigma \mathbf{F} = \mathbf{F}_{net} = m\mathbf{a}$ | $h = \text{height}$ |
| $\mathbf{F} = \frac{d\mathbf{p}}{dt}$ | $I = \text{rotational inertia}$ |
| $\mathbf{J} = \int \mathbf{F} dt = \Delta\mathbf{p}$ | $J = \text{impulse}$ |
| $\mathbf{p} = m\mathbf{v}$ | $K = \text{kinetic energy}$ |
| $F_{fric} \leq \mu N$ | $k = \text{spring constant}$ |
| $W = \int \mathbf{F} \cdot d\mathbf{r}$ | $\ell = \text{length}$ |
| $K = \frac{1}{2}mv^2$ | $L = \text{angular momentum}$ |
| $P = \frac{dW}{dt}$ | $m = \text{mass}$ |
| $P = \mathbf{F} \cdot \mathbf{v}$ | $N = \text{normal force}$ |
| $\Delta U_g = mgh$ | $P = \text{power}$ |
| $a_c = \frac{v^2}{r} = \omega^2 r$ | $p = \text{momentum}$ |
| $\boldsymbol{\tau} = \mathbf{r} \times \mathbf{F}$ | $r = \text{radius or distance}$ |
| $\Sigma \boldsymbol{\tau} = \boldsymbol{\tau}_{net} = I\boldsymbol{\alpha}$ | $\mathbf{r} = \text{position vector}$ |
| $I = \int r^2 dm = \Sigma mr^2$ | $T = \text{period}$ |
| $\mathbf{r}_{cm} = \Sigma m\mathbf{r} / \Sigma m$ | $t = \text{time}$ |
| $v = r\omega$ | $U = \text{potential energy}$ |
| $\mathbf{L} = \mathbf{r} \times \mathbf{p} = I\boldsymbol{\omega}$ | $v = \text{velocity or speed}$ |
| $K = \frac{1}{2}I\omega^2$ | $W = \text{work done on a system}$ |
| $\omega = \omega_0 + \alpha t$ | $x = \text{position}$ |
| $\theta = \theta_0 + \omega_0 t + \frac{1}{2}\alpha t^2$ | $\mu = \text{coefficient of friction}$ |
| | $\theta = \text{angle}$ |
| | $\tau = \text{torque}$ |
| | $\omega = \text{angular speed}$ |
| | $\alpha = \text{angular acceleration}$ |

ELECTRICITY AND MAGNETISM

| | |
|---|--|
| $F = \frac{1}{4\pi\epsilon_0} \frac{q_1q_2}{r^2}$ | $A = \text{area}$ |
| $\mathbf{E} = \frac{\mathbf{F}}{q}$ | $B = \text{magnetic field}$ |
| $\oint \mathbf{E} \cdot d\mathbf{A} = \frac{Q}{\epsilon_0}$ | $C = \text{capacitance}$ |
| $E = -\frac{dV}{dr}$ | $d = \text{distance}$ |
| $V = \frac{1}{4\pi\epsilon_0} \sum_i \frac{q_i}{r_i}$ | $E = \text{electric field}$ |
| $U_E = qV = \frac{1}{4\pi\epsilon_0} \frac{q_1q_2}{r}$ | $\mathcal{E} = \text{emf}$ |
| $C = \frac{Q}{V}$ | $F = \text{force}$ |
| $C = \frac{\kappa\epsilon_0 A}{d}$ | $I = \text{current}$ |
| $C_p = \sum_i C_i$ | $J = \text{current density}$ |
| $\frac{1}{C_s} = \sum_i \frac{1}{C_i}$ | $L = \text{inductance}$ |
| $I = \frac{dQ}{dt}$ | $\ell = \text{length}$ |
| $U_c = \frac{1}{2}QV = \frac{1}{2}CV^2$ | $n = \text{number of loops of wire per unit length}$ |
| $R = \frac{\rho\ell}{A}$ | $N = \text{number of charge carriers per unit volume}$ |
| $\mathbf{E} = \rho\mathbf{J}$ | $P = \text{power}$ |
| $I = Nev_d A$ | $Q = \text{charge}$ |
| $V = IR$ | $q = \text{point charge}$ |
| $R_s = \sum_i R_i$ | $R = \text{resistance}$ |
| $\frac{1}{R_p} = \sum_i \frac{1}{R_i}$ | $r = \text{distance}$ |
| $P = IV$ | $t = \text{time}$ |
| $\mathbf{F}_M = q\mathbf{v} \times \mathbf{B}$ | $U = \text{potential or stored energy}$ |
| | $V = \text{electric potential}$ |
| | $v = \text{velocity or speed}$ |
| | $\rho = \text{resistivity}$ |
| | $\phi_m = \text{magnetic flux}$ |
| | $\kappa = \text{dielectric constant}$ |

ADVANCED PLACEMENT PHYSICS C EQUATIONS FOR 2008 and 2009

GEOMETRY AND TRIGONOMETRY

Rectangle

$$A = bh$$

Triangle

$$A = \frac{1}{2}bh$$

Circle

$$A = \pi r^2$$

$$C = 2\pi r$$

Parallelepiped

$$V = \ell wh$$

Cylinder

$$V = \pi r^2 \ell$$

$$S = 2\pi r \ell + 2\pi r^2$$

Sphere

$$V = \frac{4}{3}\pi r^3$$

$$S = 4\pi r^2$$

Right Triangle

$$a^2 + b^2 = c^2$$

$$\sin \theta = \frac{a}{c}$$

$$\cos \theta = \frac{b}{c}$$

$$\tan \theta = \frac{a}{b}$$

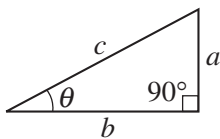

A = area
 C = circumference
 V = volume
 S = surface area
 b = base
 h = height
 ℓ = length
 w = width
 r = radius

CALCULUS

$$\frac{df}{dx} = \frac{df}{du} \frac{du}{dx}$$

$$\frac{d}{dx}(x^n) = nx^{n-1}$$

$$\frac{d}{dx}(e^x) = e^x$$

$$\frac{d}{dx}(\ln x) = \frac{1}{x}$$

$$\frac{d}{dx}(\sin x) = \cos x$$

$$\frac{d}{dx}(\cos x) = -\sin x$$

$$\int x^n dx = \frac{1}{n+1}x^{n+1}, n \neq -1$$

$$\int e^x dx = e^x$$

$$\int \frac{dx}{x} = \ln|x|$$

$$\int \cos x dx = \sin x$$

$$\int \sin x dx = -\cos x$$

Contact Us

National Office

Advanced Placement Program
45 Columbus Avenue
New York, NY 10023-6992
212 713-8066
E-mail: ap@collegeboard.org

AP Services

P.O. Box 6671
Princeton, NJ 08541-6671
609 771-7300
877 274-6474 (toll free in the U.S.
and Canada)
E-mail: apexams@info.collegeboard.org

AP Canada Office

2950 Douglas Street, Suite 550
Victoria, BC, Canada V8T 4N4
250 472-8561
800 667-4548 (toll free in Canada only)
E-mail: gewonus@ap.ca

AP International Office

Serving all countries outside the U.S. and Canada
45 Columbus Avenue
New York, NY 10023-6992
212 373-8738
E-mail: apintl@collegeboard.org

Middle States Regional Office

*Serving Delaware, District of Columbia, Maryland,
New Jersey, New York, Pennsylvania,
Puerto Rico, and the U.S. Virgin Islands*
Two Bala Plaza, Suite 900
Bala Cynwyd, PA 19004-1501
866 392-3019
E-mail: msro@collegeboard.org

Midwestern Regional Office

*Serving Illinois, Indiana, Iowa, Kansas,
Michigan, Minnesota, Missouri,
Nebraska, North Dakota, Ohio, South Dakota,
West Virginia, and Wisconsin*
6111 N. River Road, Suite 550
Rosemont, IL 60018-5158
866 392-4086
E-mail: mro@collegeboard.org

New England Regional Office

*Serving Connecticut, Maine, Massachusetts, New
Hampshire, Rhode Island, and Vermont*
470 Totten Pond Road
Waltham, MA 02451-1982
866 392-4089
E-mail: nero@collegeboard.org

Southern Regional Office

*Serving Alabama, Florida, Georgia, Kentucky,
Louisiana, Mississippi, North Carolina, South Carolina,
Tennessee, and Virginia*
3700 Crestwood Parkway NW, Suite 700
Duluth, GA 30096-7155
866 392-4088
E-mail: sro@collegeboard.org

Southwestern Regional Office

Serving Arkansas, New Mexico, Oklahoma, and Texas
4330 South MoPac Expressway, Suite 200
Austin, TX 78735-6735
866 392-3017
E-mail: swro@collegeboard.org

Western Regional Office

*Serving Alaska, Arizona, California, Colorado, Hawaii,
Idaho, Montana, Nevada, Oregon, Utah, Washington,
and Wyoming*
2099 Gateway Place, Suite 550
San Jose, CA 95110-1051
866 392-4078
E-mail: wro@collegeboard.org



2006-07 Development Committee and Chief Reader

Laurence Cain, Davidson College, North Carolina, *Chair*

Angela Benjamin, Woodrow Wilson Senior High School, Washington, D.C.

Dolores Gende, Parish Episcopal School, Dallas, Texas

Martin Kirby, William S. Hart High School, Newhall, California

Ingrid Novodvorsky, University of Arizona, Tucson

Scott Saltman, Phillips Exeter Academy, Exeter, New Hampshire

Beth Ann Thacker, Texas Tech University, Lubbock

Chief Reader: **William Ingham**, James Madison University, Harrisonburg, Virginia

ETS Consultants: **Will Pfeiffenberger, Ann Marie Zolandz**

apcentral.collegeboard.com

I.N. 060081994