

# R66<sup>®</sup> *TURBINE* HELICOPTER



**ROBINSON HELICOPTER COMPANY**

2901 Airport Drive • Torrance, CA • 90505 • USA • Phone: 310-539-0508 • Fax: 310-539-5198 • [www.robinsonheli.com](http://www.robinsonheli.com)

The **ROBINSON R66 TURBINE** incorporates many of the design features of the R44, including a two-bladed rotor system, T-bar cyclic and an open interior cabin configuration. Notable differences are the R66's increased reserve power, improved altitude performance, fifth seat, and large baggage compartment. Popular upgrades including HID landing lights, leather seats, and a stereo audio control panel are standard in the R66.

## DIMENSIONS

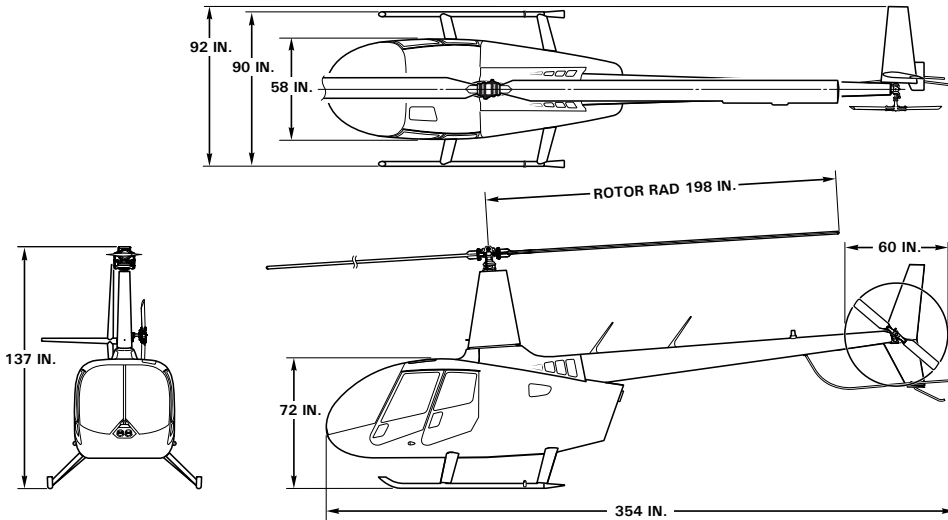

The Rolls Royce RR300 turboshaft engine was specifically designed for the R66.



Five seats in an open cabin configuration provide passengers comfort and an unobstructed view.

## SPECIFICATIONS

*Based on preliminary test data and subject to change*

### Performance:

Cruise Speed . . . . . approx 120 kts  
 Max Range (no reserve) . . . approx 325 nm/375 miles  
 Hover Ceiling IGE . . . . . over 10,000 ft  
 Hover Ceiling OGE . . . . . over 10,000 ft  
 Rate of Climb. . . . . over 1,000 fpm  
 Max Operating Altitude . . . . . 14,000 ft

### Weights:

Gross Weight . . . . . 2,700 lbs  
 Empty Weight (incl oil & std avionics) . . . 1,280 lbs  
 Max Fuel (73.6 gal). . . . . 493 lbs  
 Passengers & Baggage (with max fuel) . . . 927 lbs



A large baggage compartment accommodates full-sized luggage.

Shaded area indicates footprint of optional 9-hole instrument panel



### R66 TURBINE COCKPIT

Shown with 7-hole instrument panel and optional Pilot's Avionics Console