

CHARACTERISTICS, DEVELOPMENT AND UTILIZATION OF GEOTHERMAL RESOURCES

John W. Lund, Geo-Heat Center, Oregon Institute of Technology

INTRODUCTION

Early humans probably used geothermal water that occurred in natural pools and hot springs for cooking, bathing and to keep warm. We have archeological evidence that the Indians of the Americas occupied sites around these geothermal resources for over 10,000 years to recuperate from battle and take refuge. Many of their oral legends describe these places and other volcanic phenomena. Recorded history shows uses by Romans, Japanese, Turks, Icelanders, Central Europeans and the Maori of New Zealand for bathing, cooking and space heating. Baths in the Roman Empire, the middle kingdom of the Chinese, and the Turkish baths of the Ottomans were some of the early uses of balneology; where, body health, hygiene and discussions were the social custom of the day. This custom has been extended to geothermal spas in Japan, Germany, Iceland, and countries of the former Austro-Hungarian Empire, the Americas and New Zealand. Early industrial applications include chemical extraction from the natural manifestations of steam, pools and mineral deposits in the Larderello region of Italy, with boric acid being extracted commercially starting in the early 1800s. At Chaudes-Aigues in the heart of France, the world's first geothermal district heating system was started in the 14th century and is still going strong. The oldest geothermal district heating project in the United States is on Warm Springs Avenue in Boise, Idaho, going on line in 1892 and continues to provide space heating for up to 450 homes.

The first use of geothermal energy for electric power production was in Italy with experimental work by Prince Gionori Conti between 1904 and 1905. The first commercial powerplant (250 kWe) was commissioned in 1913 at Larderello, Italy. An experimental 35 kWe plant was installed in The Geysers in 1932, and provided power to the local resort. These developments were followed in New Zealand at Wairakei in 1958; an experimental plant at Pathe, Mexico in 1959; and the first commercial plant at The Geysers in the United States in 1960. Japan followed with 23 MWe at Matsukawa in 1966. All of these early plants used steam directly from the earth (dry steam fields), except for New Zealand, which was the first to use flashed or separated steam for running the turbines. The former USSR produced power from the first true binary power plant, 680 kWe using 81°C water at Paratunka on the Kamchatka peninsula – the lowest temperature, at that time. Iceland first produced power at Namafjall in northern Iceland, from a 3 MWe non-condensing turbine. These were followed by plants in El Salvador, China, Indonesia, Kenya, Turkey, Philippines, Portugal (Azores), Greece and Nicaragua in the 1970s and 80s. Later plants were installed in Thailand, Argentina, Taiwan, Australia, Costa Rica, Austria, Guatemala, Ethiopia, with the latest installations in Germany and Papua New Guinea. (See Cataldi, et al., 1999 for more background).

GHC BULLETIN, JUNE 2007

TYPES OF GEOTHERMAL RESOURCES

Geothermal energy comes from the natural generation of heat primarily due to the decay of the naturally occurring radioactive isotopes of uranium, thorium and potassium in the earth. Because of the internal heat generation, the Earth's surface heat flow averages 82 mW/m² which amounts to a total heat loss of about 42 million megawatts. The estimated total thermal energy above mean surface temperature to a depth of 10 km is 1.3×10^{27} J, equivalent to burning 3.0×10^{17} barrels of oil. Since the global energy consumptions for all types of energy, is equivalent to use of about 100 million barrels of oil per day, the Earth's energy to a depth of 10 kilometers could theoretically supply all of mankind's energy needs for six million years (Wright, 1998).

On average, the temperature of the Earth increases about 30°C/km above the mean surface ambient temperature. Thus, assuming a conductive gradient, the temperature of the earth at 10 km would be over 300°C. However, most geothermal exploration and use occurs where the gradient is higher, and thus where drilling is shallower and less costly. These shallow depth geothermal resources occur due to: (1) intrusion of molten rock (magma) from depth, bringing up great quantities of heat; (2) high surface heat flow, due to a thin crust and high temperature gradient; (3) ascent of groundwater that has circulated to depths of several kilometers and been heated due to the normal temperature gradient; (4) thermal blanketing or insulation of deep rocks by thick formation of such rocks as shale whose thermal conductivity is low; and. (5) anomalous heating of shallow rock by decay of radioactive elements, perhaps augmented by thermal blanketing (Wright, 1998).

Geothermal resources are usually classified as shown in Table 1, modeled after White and Williams (1975). These geothermal resources range from the mean annual ambient temperature of around 20°C to over 300°C. In general, resources above 150°C are used for electric power generation, although power has recently been generated at Chena Hot Springs Resort in Alaska using a 74°C geothermal resource (Lund, 2006). Resources below 150°C are usually used in direct-use projects for heating and cooling. Ambient temperatures in the 5 to 30°C range can be used with geothermal (ground-source) heat pumps to provide both heating and cooling.

Convective hydrothermal resources occur where the Earth's heat is carried upward by convective circulation of naturally occurring hot water or steam. Some high-temperature convective hydrothermal resources result from deep circulation of water along fractures.

Table 1. Geothermal Resource Types

Resource Type	Temperature Range (°C)
Convective hydrothermal resources	
Vapor dominated	240°
Hot-water dominated	20 to 350°+
Other hydrothermal resources	
Sedimentary basin	20 to 150°
Geopressed	90 to 200°
Radiogenic	30 to 150°
Hot rock resources	
Solidified (hot dry rock)	90 to 650°
Part still molten (magma)	>600°

Vapor dominated systems (Fig. 1) produce steam from boiling of deep, saline waters in low permeability rocks. These reservoirs are few in number, with The Geysers in northern California, Larderello in Italy and Matsukawa in Japan being ones where the steam is exploited to produce electric energy.

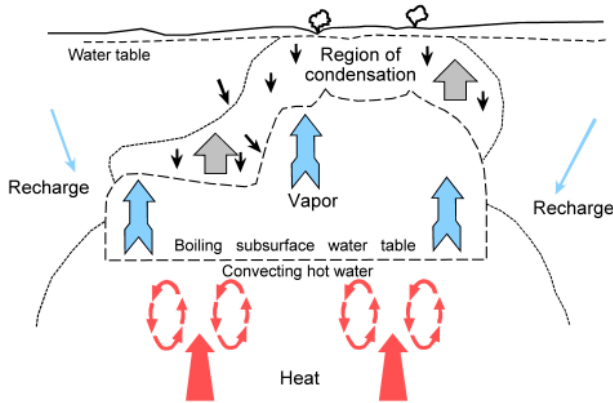

Figure 1. Vapor dominated geothermal system. (White, et al., 1971)

Water dominated systems (Fig.2) are produced by ground water circulating to depth and ascending from buoyancy in permeable reservoirs that are a uniform temperature over large volumes. There is typically an upflow zone at the cen-

ter of each convection cell, an outflow zone or plume of heated water moving laterally away from the center of the system, and a downflow zone where recharge is taking place. Surface manifestations include hot springs, fumaroles, geysers, travertine deposits, chemically altered rocks, or sometimes, no surface manifestations (a blind resource).

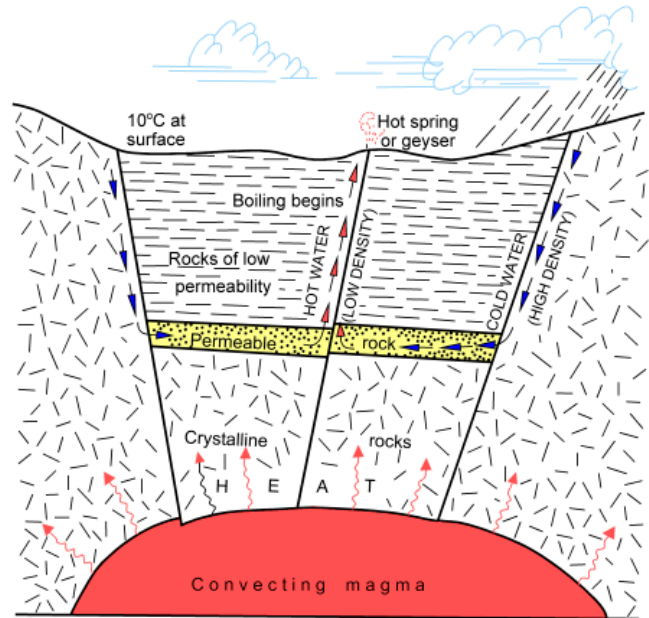

Figure 2. Hot water dominated geothermal system. (White, et al., 1971)

Sedimentary basins (Fig. 3) produce higher temperature resources than the surrounding formations due to their low thermal conductivity or high heat flow or both producing geothermal gradients $>30^{\circ}\text{C}/\text{km}$. These generally extend over large areas and are typical of the Madison Formation of North Dakota, South Dakota, Montana and Wyoming area of the northern United States and the Pannonian Basin of central Europe where it has been used extensively in Hungary.

Geopressed resources (Fig. 4) occur in basin environments where deeply buried fluids contained in permeable sedimentary rocks are warmed in a normal or enhanced geothermal gradient by their great burial depth. The fluids are tightly confined by surrounding impermeable rock and bear

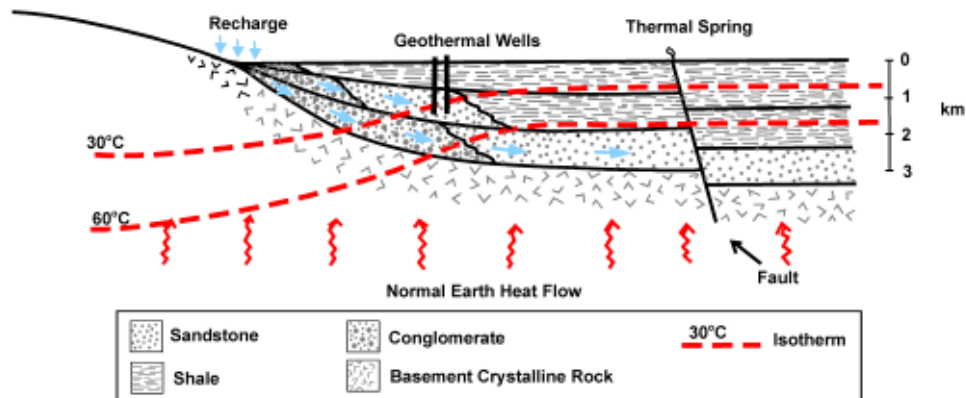

Figure 3. Sedimentary basin geothermal resource. (Anderson & Lund, 1979)

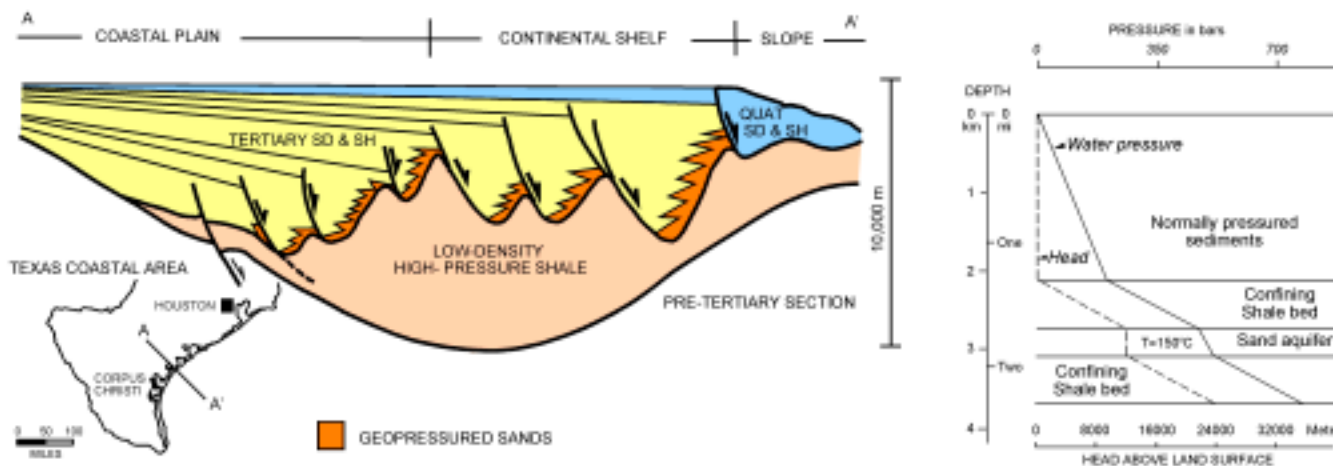

Figure 4. Geopressured geothermal system. (Bebout, et al., 1978)

pressure much greater than hydrostatic. Thermal waters under high pressure in sand aquifers are the target for drilling, mainly as they contain dissolved methane. The source of energy available from this type of resource consists of: (1) heat; (2) mechanical energy; and, (3) methane. The Texas and Louisiana Gulf Coast in the United States has been tested for the geothermal energy; however, due to the great depths of several kilometers, they have not proved economic.

Radiogenic resources (Fig. 5) are found where granitic intrusions are near surface heating up the local groundwater from the decay of radioactive thorium, potassium and uranium. This localized heating increases the normal geothermal gradient providing hot water at economical drilling depths. This type of resource occurs along the eastern United States, but has not been developed commercially.

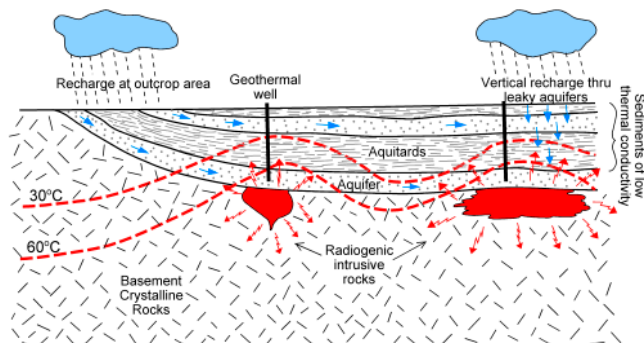

Figure 5. Radiogenic geothermal system. (Anderson & Lund, 1979)

Hot dry rock resources (Fig. 6a & b) are defined as heat stored in rocks within about 10 km of the surface from which energy cannot be economically extracted by natural hot water or steam. These hot rocks have few pore space, or fractures, and therefore, contain little water and little or no interconnected permeability. In order to extract the heat, experimental projects have artificially fractured the rock by hydraulic pressure, followed by circulating cold water down one well to extract the heat from the rocks and then producing from a second well in a closed system. Early experimental projects were undertaken at Fenton Hill (Valdes Caldera) in northern New Mexico and on Cornwall in southwest Eng-

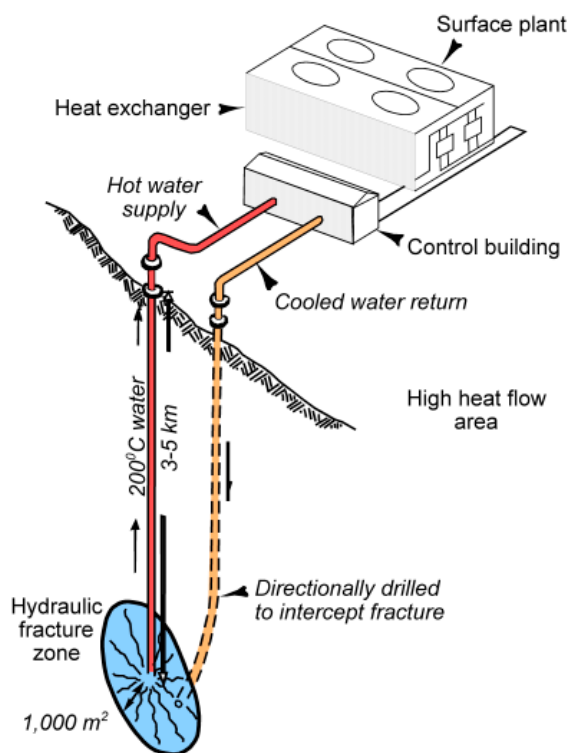

Figure 6a. Hot dry rock exploitation.

land; however both of these projects have been abandoned due to lack of funds and poor results. Projects are currently underway in Soultz-sous-Forêt in the Rhine Graben on the French-German border, in Switzerland at Basil and Zurich, in Germany at Bad Urach, several locations in Japan, and in the Cooper Basin of Australia (Tenzer, 2001).

Molten rock or magma resources have been drilled in Hawaii experimentally to extract heat energy directly from molten rock. It has been used successfully at Heimae in Iceland (one of the Westmann Islands) after the 1973 eruption. A heat exchanger constructed on the surface of the lava flow recovered steam resulting from boiling of downward percolation water from the surface. The heat was used in a space heating system for over 10 years; but, is now shut down due to cooling of the surrounding rock.

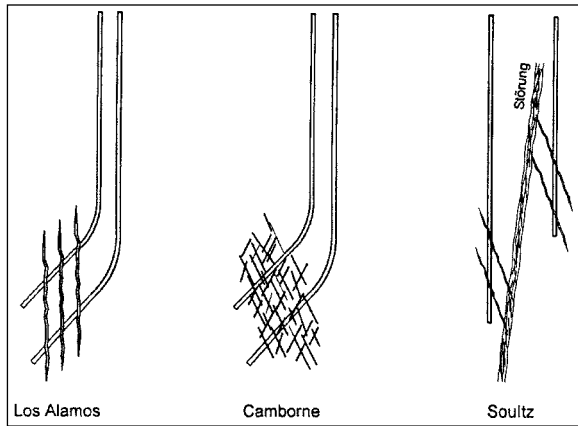

Figure 6b. Examples of hydraulic fracturing. (Tenzer, 2001)

UTILIZATION IN 2005

Based on 68 country update papers submitted to the World Geothermal Congress 2005 (WGC 2005) held in Turkey, the following figures on worldwide geothermal electric and direct-use capacity, are reported. A total of 72 countries have reported some utilization from WGC 2000 and WGC 2005, either electric, direct-use or both (Lund and Freeston, 2001; Lund, et al., 2005a; Bertani, 2005) (Table 2).

Table 2. Total Geothermal Use in 2005

Use	Installed Power MW	Annual Energy Use GWh/yr	Capacity Factor	Countries Reporting
Electric Power	8,933	56,786	0.73	24
Direct Use	28,268	75,943	0.31	72

The figures for electric power capacity (MWe) appear to be fairly accurate; however, several of the country's annual generation values (GWh) had to be estimated which amounted to only 0.5% of the total. The direct-use figures are less reliable and probably are understated by as much as 20%. The author is also aware of at least five countries, which utilize geothermal energy for direct-heat applications, but did not submit reports to WGC 2005. The details of the present installed electric power capacity and generation, and direct-use of geothermal energy can be found in Bertani (2005), and Lund, et al., 2005a. These data are summarized in Table 3.

A review of the above data shows that in electric power generation each major continent has approximately the same percentage share of the installed capacity and energy produced with North America and Asia having over 80% of the total. Whereas, with the direct-use figures, the percentages drop significantly from installed capacity to energy use for the Americas (32.3 to 16.7%) due to the high percentage of geothermal heat pumps with a low capacity factor for these units in the United States. On the other hand, the percentages increased for the remainder of the world due to a lesser reliance on geothermal heat pumps, and the greater number of operating hours per year for these units.

Table 3. Summary of Regional Geothermal Use in 2005

Region	Electric Power		Direct-Use	
	%MWe	%GWh/yr	%MWt	%GWh/yr
Africa	1.5	1.9	0.7	1.1
Americas	43.9	47.0	32.3	16.7
Asia	37.2	33.8	20.9	29.4
Europe	12.4	12.4	44.6	49.0
Oceania	5.0	4.9	1.5	3.8

ELECTRIC POWER GENERATION

Geothermal power is generated by using steam or a secondary hydrocarbon vapor to turn a turbine-generator set to produce electrons. A vapor dominated (dry steam) resource (see Fig. 1 and 7) can be used directly, whereas a hot water resource (see Fig. 2 and 8) needs to be flashed by reducing the pressure to produce steam. In the case of low temperature resource, generally below 150°C, the use of a secondary low boiling point fluid (hydrocarbon) is required to generate the vapor, in a binary or organic Rankine cycle plant (see Fig. 9). Usually a wet or dry cooling tower is used to condense the vapor after it leaves the turbine to maximize the temperature drop between the incoming and outgoing vapor and thus increase the efficiency of the operation. The worldwide installed capacity has the following distribution: 29% dry steam, 37% single flash, 25% double flash, 8% binary/combined cycle/hybrid, and 1% backpressure (Bertani, 2005) (Figures 8 & 9 courtesy EGI).

Electric power has been produced from geothermal energy in 27 countries; however, Greece, Taiwan and Argentina have shut down their plants, due to environmental and economic reasons. Since 2000, the installed capacity in the world has increased almost 1,000 MWe. Since 2000, additional plants have been installed in Costa Rica, France on Guadeloupe in the Caribbean, Iceland, Indonesia, Kenya, Mexico, and the Phillipines. In 2004, Germany installed a 210-kWe binary plant at Neustadt Glewe and a 6-MWe plant has been installed on Papua New Guinea to generate electricity for a remote mine. Russia has completed a new 50-

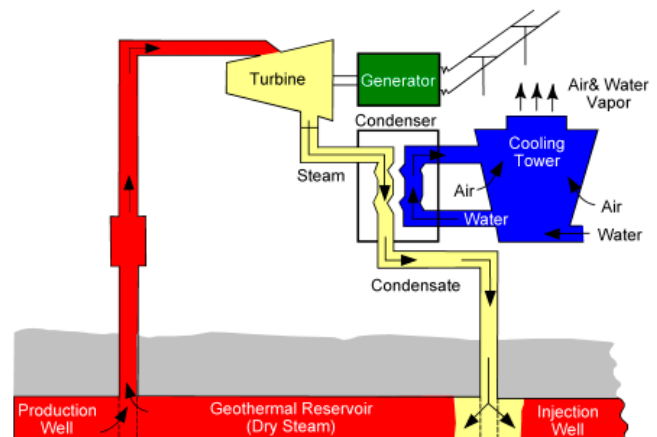

Figure 7. Steam plant using a vapor or dry steam dominated geothermal resource.

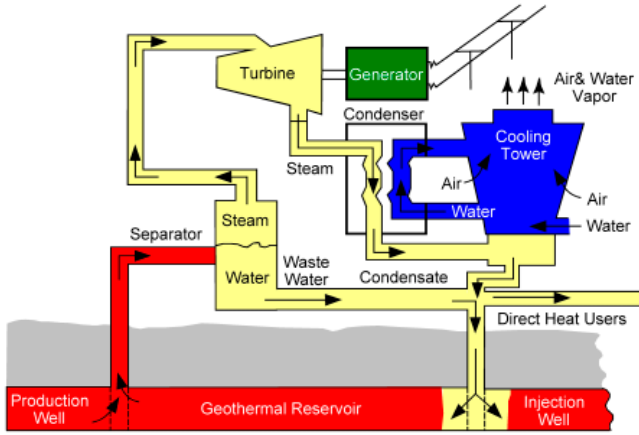

Figure 8. Flash steam plant using a water-dominated geothermal resource with a separator to produce steam.

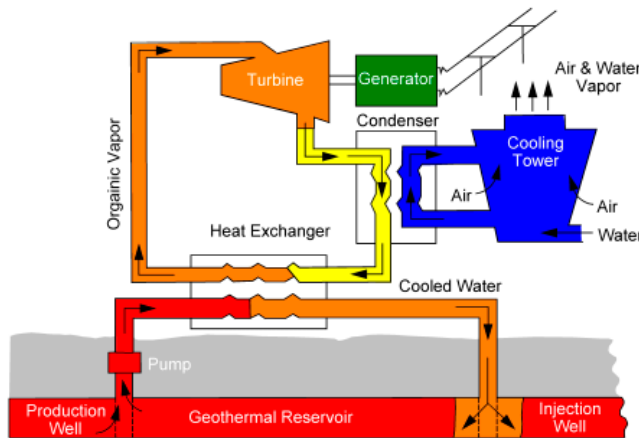

Figure 9. Binary power or organic Rankine cycle plant using a low temperature geothermal resource and a secondary fluid of a low boiling-point hydrocarbon.

MWe plant on Kamchatka. More recently, a 200 kWe binary plant using 74°C geothermal water and 4°C cooling water was installed at Chena Hot Springs Resort in Alaska (Lund,

2006). The operating capacity in the United States has increased since 1995 due to completion of the two effluent pipelines injecting treated sewage water at The Geysers. In an attempt to bring production back, the Southeast Geysers Effluent Recycling Project is now injecting 340 L/s of treated wastewater through a 48-km long pipeline from Clear Lake, adding 77 MWe. A second, 66-km long pipeline from Santa Rosa was placed on-line in 2004, injecting 480 L/s that are projected to add another 100 MWe to The Geysers' capacity. Table 4 lists the leading countries producing electric power.

A recent report (Bertani, 2007) indicates that geothermal installed capacity per power generation has increased to 9,732 MWe.

One of the more significant aspects of geothermal power development is the size of its contribution to national and regional capacity and production of countries. Table 5 shows the countries or regions that lead in this contribution with more than 5% of the electrical energy supplied by geothermal power based on data from WGC2005 (Bertani, 2005).

DIRECT UTILIZATION

Direct-use of geothermal resources is primarily for direct heating and cooling. The main utilization categories are: (1) swimming, bathing and balneology; (2) space heating and cooling including district energy systems; (3) agricultural applications such as greenhouse and soil heating; (4) aquaculture application such as pond and raceway water heating; (5) industrial applications such as mineral extraction, food and grain drying; and, (6) geothermal (ground-source) heat pumps (GHP), used for both heating and cooling. Direct-use of geothermal resources normally uses temperatures below 150°C as illustrated in Figure 10. The main advantage of using geothermal energy for direct use projects in this low- to intermediate-temperature range is that these resources are more widespread and exists in at least 80 countries at economic drilling depths. In addition, there are no conversion

Table 4. Leading Countries in Electric Power Generation (>100 MWe) (Bertani, 2005)

Country	Installed Capacity, MWe	Running Capacity, MWe	Annual Energy Produced, GWh/yr	Running Capacity Factor	Number of Units Operating
United States*	2534	2133	17,840	0.95	209
Philippines	1930	1838	9,253	0.57	57
Mexico	953	953	6,282	0.75	36
Indonesia	797	838	6,085	0.83	15
Italy	791	699	5,340	0.87	32
Japan	535	530	3,467	0.75	19
New Zealand	435	403	2,774	0.79	33
Iceland	202	202	1,483	0.84	19
Costa Rica	163	163	1,145	0.80	5
El Salvador	151	119	967	0.93	5
Kenya	129	129	1,088	0.96	9

*USA figures revised based on (Lund, et al. 2005b)

Table 5. National and Regional Geothermal Power Contributions

Country or Region	% of National or Regional Capacity (MWe)	% of National or Regional Energy (GWh/yr)
Tibet	30.0	30.0
San Miguel Island, Azores	25.0	n/a
Tuscany, Italy	25.0	25.0
El Salvador	14.0	24.0
Iceland	13.7	16.6
Philippines	12.7	19.1
Nicaragua	11.2	9.8
Kenya	11.2	19.2
Lihir Island, Papua New Guinea	10.9	n/a
Guadeloupe (Caribbean)	9.0	9.0
Costa Rica	8.4	15.0
New Zealand	5.5	7.1

efficiency losses and projects commonly use conventional water-well drilling and off-the-shelf heating and cooling equipment (allowing for the temperature and chemistry of the fluid). Most projects can be on line in less than a year. Projects can be on a small scale (“mom and pop operations”) such as for an individual home, single greenhouse or aquaculture pond, but can also be a large scale operation such as for district heating/cooling and for food and lumber drying, and mineral ore extraction. It is often necessary to isolate the geothermal fluid from the user side to prevent corrosion and scaling.

Care must be taken to prevent oxygen from entering the system (geothermal water normally is oxygen free), and dissolved gases and minerals such as boron, arsenic, and hydrogen sulfide must be removed or isolated as they are harmful to plants and animals. On the other hand, carbon dioxide, which often occurs in geothermal water, can be extracted and used for carbonated beverages or to enhance growth in greenhouses. The typical equipment for a direct-use system is illustrated in Figure 11, and includes, downhole and circulation pumps, heat exchangers (normally the plate type), transmission and distribution lines (normally insulated pipes), heat extraction equipment, peaking or back-up plants (usually fossil fuel fired) to reduce the use of geothermal fluids and reduce the number of wells required, and fluid disposal system (injection wells). Geothermal energy can usually meet 95% of the annual heating or cooling demand, yet only be sized for 50% of the peak load. Geothermal heat pumps include both open (using ground-water or lake water) and closed loop (either in horizontal or vertical configuration) systems as illustrated in Figure 12.

The world direct utilization of geothermal energy is difficult to determine; as, there are many diverse uses of the energy and these are sometimes small and located in remote areas. Finding someone, or even a group of people in a country who are knowledgeable on all the direct uses is difficult. In addition, even if the use can be determined, the flow rates and temperatures are usually not known or reported; thus, the capacity and energy use can only be estimated. This is especially true of geothermal waters used for swimming pools, bathing and balneology. Thus, it is difficult to compare changes from one report to the next. This was especially true of Japan and Hungary in the WGC 2000 country updates, as a significant portion of this use was not reported, and was obtained from other sources. For this reason, the values reported in Lund and Freeston (2001),

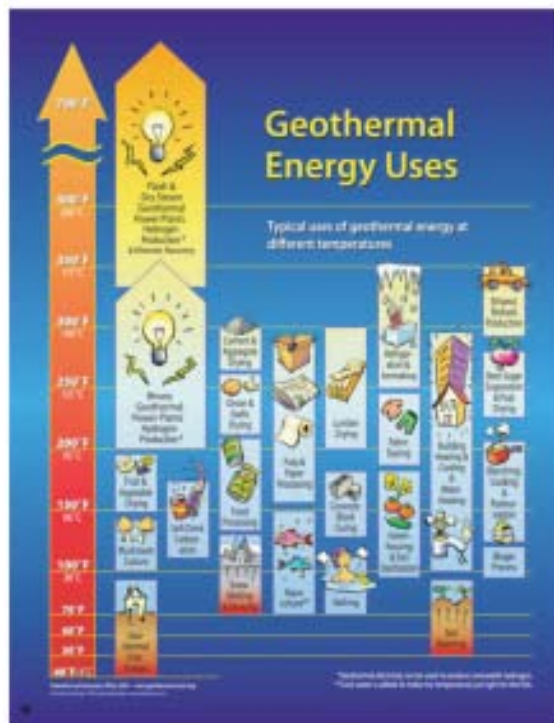

Figure 10. Geothermal energy uses. (Geothermal Education Office)

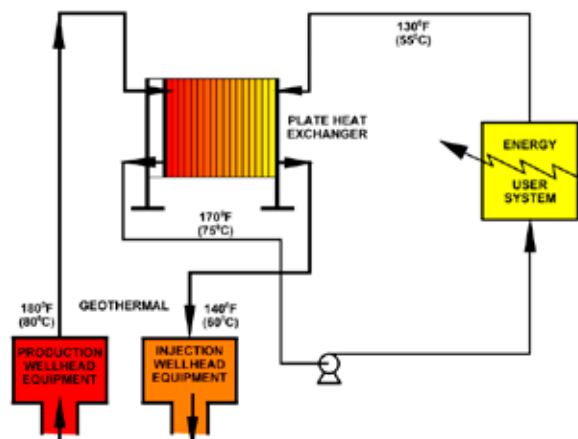

Figure 11. Typical direct use geothermal heating system configuration.

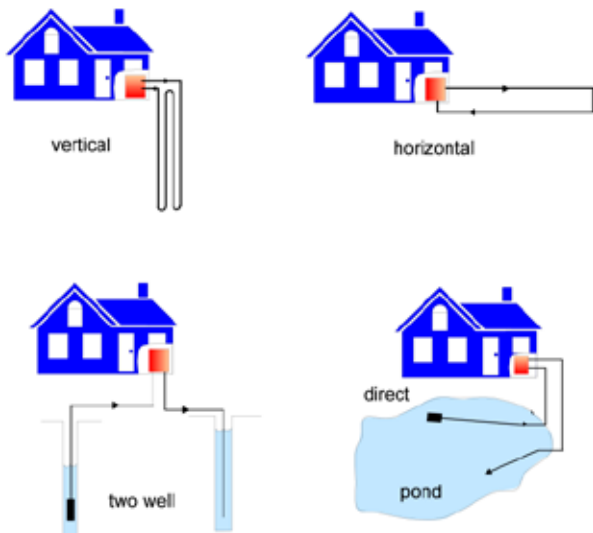

Figure 12. Examples of common geothermal heat pump installations.

have been updated for this paper based on data for WGC 2005 (Lund, et al., 2005a).

One of the significant changes for WGC2005 was the increase in the number of countries reporting use. Fourteen countries were added to the list in the current report as compared to 2000. In addition, the author is aware of four countries (Malaysia, Mozambique, South Africa, and Zambia) that have geothermal direct-uses, but did not provide a report for WGC2005. Thus, there are at least 76 countries with some form of direct utilization of geothermal energy. Table 6 lists the top direct-use countries.

Table 6. Top Direct-Use Countries

Country	GWh/yr	MWt	Main Applications
China	12,605	3,687	bathing
Sweden	12,000	4,200	GHP
USA	8,678	7,817	GHP
Turkey	6,900	1,495	district heating
Iceland	6,806	1,844	district heating
Japan	2,862	822	bathing (onsens)
Hungary	2,206	694	spas/greenhouses
Italy	2,098	607	spas/space heating
New Zealand	1,969	308	industrial uses

Another significant change from 2000 is the large increase in geothermal (ground-source) heat pump installations. They increased by 198% (24% annual growth) in capacity and 272% (30% annual growth) in energy produced over the five-year period to the year 2005. By 2005, they were the largest portion of the installed capacity (56.5%) and 33.2% of the annual energy use. The actual number of installed units is around 1,700,000 in 33 countries, mostly in the United States and Europe; however, the data are incomplete. The equivalent number of 12-kWt units installed (the average size) is approximately 1,500,000. The equivalent number of

full-load heating operating hours per year varies from 1,200 in the U.S., to over 6,000 in Sweden and Finland, with a worldwide average of 2,200 full-load hours/year.

A summary of direct-use installed capacity and annual energy use are as follows: geothermal heat pumps 56.5% and 33.2%; bathing/swimming/spas 17.7% and 28.8%, space heating (including district heating) 14.9% and 20.2%; greenhouse heating 4.8% and 7.5%; aquaculture 2.2% and 4.2%; industrial 1.8% and 4.2%; agricultural drying 0.6% and 0.8%, cooling and snow melting 1.2% and 0.7%; and others 0.3% and 0.4%. District heating is approximately 80% of the space heating use.

In terms of the contribution of geothermal direct-use to the national energy budget, two countries stand out: Iceland and Turkey. In Iceland, it provides 89% of the country's space heating needs, which is important since heating is required almost all year and saves about 100 million US\$ in imported oil. Turkey has increased their installed capacity over the past five years from 820 MWt to 1,495 MWt, most for district heating systems. A summary of some of the significant geothermal direct-use contributions to various countries is shown in Table 7.

Table 7. National Geothermal Direct-Use Contributions

Iceland	provides 89% of country's space heating needs;
Turkey	space heating has increased 50% in the past 5 years, supplying 65,000 equivalent residences and 30% of the country will be heated with geothermal by 2010
Tunisia	greenhouse heating has increased from 10 ha to 100 ha over the past 10 years
Japan	over 2,000 hot spring resorts (onsens), over 5,000 public bath houses, and over 15,000 hotels, visited by 14.5 million guests per year, use natural hot springs
Switzerland	has installed 30,000 geothermal heat pumps = one/two km ² , and 1,000 boreholes are drilled annually. Drain water from tunnels are used to heat nearby villages and they have also developed several geothermal projects to melt snow and ice on roads
United States	has installed 700,000 geothermal heat pump units, mainly in the midwestern and eastern states, with a 15% annual growth. Installation of these units is around 50,000 to 60,000 per year

ENVIRONMENTAL CONSIDERATIONS

Geothermal resources are considered renewable and "green" (Rybach, 2007); however, there are several environmental impacts that must be considered during utilization that are usually mitigated. These are emission of harmful gases, noise pollution, water use and quality, land use, and impact on natural phenomena, wildlife and vegetation (Kagel, et al., 2005).

Emissions: These are usually associated with steam power plant cooling towers that produce water vapor emission (steam), not smoke. The potential gases that can be released, depending upon the reservoir type are carbon dioxide, sulfur dioxide, nitrous oxides, hydrogen sulfide along with particulate matter. A coal-fired power plant produces the following kilograms of emissions per MWh as compared to a geothermal power plant: 994 vs. up to 40 for carbon dioxide, 4.71 vs. up to 0.16 for sulfur dioxide, 1.95 vs. 0 for nitrogen oxides, 0 vs. 0.08 for hydrogen sulfide (H₂S), and 1.01 vs. 0 for particulate matter. Hydrogen sulfide is routinely treated at geothermal power plants, and converted to elemental sulfur. In comparison, oil-fired power plants produce 814 kg and natural gas fired plants 550 kg of H₂S per MWh. Binary power plants and direct-use projects normally do not produce any pollutants, as the water is injected back into the ground after use without exposing it to the atmosphere.

Noise: The majority of the noise produced at a power plant or direct-use site is during the well drilling operation, which normally shuts down at night. The noise from a power plant is not considered an issue of concern, as it is extremely low, unless you are next to or inside the plant. Most of the noise comes from cooling fans and the rotating turbines.

Water use: Geothermal plants use about 20 liters of fresh-water per MWh, while binary air-cooled plants use no fresh water, as compared to a coal plant that uses 1,370 liters per MWh. An oil plant uses about 15% less and nuclear about 25% more than the coal plant (www.cleanenergy.org). The only change in the fluid during use is to cool it, and usually the fluid is returned to the same aquifer so it does not mix with the shallow groundwater. At The Geysers facility in northern California, 42 million liters of treated wastewater from Santa Rosa are pumped daily for injection into the geothermal reservoir, reducing surface water pollution in the community and increasing the production of the geothermal field. A similar project supplies waste water from the Clear Lake area on the northeast side of the The Geysers. These projects have increased the capacity of the field by over 100 MWe.

Land use: Geothermal power plants are designed to “blend-in” with the surrounding landscape, and can be located near recreational areas with minimum land and visual impacts. They generally consist of small modular plants under 100 MWe as compared to coal or nuclear plants of around 1,000 MWe. Typically, a geothermal facility uses 404 square meters of land per GWh compared to a coal facility that uses

3,632 square meters per GWh and a wind farm that uses 1,335 square meters per GWh. Subsidence and induced seismicity are two land use issues that must be considered when withdrawing fluids from the ground. These are usually mitigated by injecting the spent fluid back into the same reservoir. There have been problems with subsidence at the Wairakei geothermal field in New Zealand; however, this has been checked by injection. Neither of these potential problems are associated with direct-use projects, as the fluid use is small and well and pipelines are usually hidden. In addition, utilizing geothermal resources eliminates the mining, processing and transporting required for electricity generation from fossil fuel and nuclear resources.

Impact on natural phenomena, wildlife and vegetation: Plants are usually prevented from being located near geysers, fumaroles and hot springs, as the extraction of fluids to run the turbines, might impact these thermal manifestations. Most plants are located in areas with no natural surface discharges. If plants are located near these natural phenomena, the fluid extraction depth is planned from a different reservoir to prevent any impact. Designers and operators are especially sensitive about preserving manifestations considered sacred to indigenous people. Any site considered for a geothermal power plant, must be reviewed and considered for the impact on wildlife and vegetation, and if significant, provide a mitigation plan. Direct use projects are usually small and thus have no significant impact on natural features.

In summary, the use of geothermal energy is reliable, providing base load power; is renewable; has minimum air emission and offsets the high air emissions of fossil fuel-fired plants; has minimum environmental impacts; is combustion free; and is a domestic fuel source.

ENERGY SAVINGS

Using geothermal energy obviously replaces fossil fuel use and prevents the emission of greenhouse gases. If we assume that geothermal energy replaces electricity generation, the conversion efficiency is estimated at 0.35 (35%). These savings using geothermal energy at this efficiency level is summarized in Table 8 (Goddard and Goddard, 1990).

If the replacement energy for direct-use is provided by burning the fuel directly, then about half this amount would be saved in heating systems (35% vs. 70% efficiency). Savings in the cooling mode of geothermal heat pumps is also included in the figures in Table 8. The savings in fossil fuel

Table 8. Energy and Greenhouse Gas Savings from Geothermal Energy Production

	Fuel Oil (10 ⁶)		Carbon (10 ⁶ t)			CO ₂ (10 ⁶ t)			SO _x (10 ⁶ t)			NO _x (10 ³ t)		
	Barrels	Tonnes	NG	Oil	Coal	NG	Oil	Coal	NG	Oil	Coal	NG	Oil	Coal
Electric	96	15	3	13	15	12	51	59	0	0.3	0.3	2.8	9.6	9.6
Direct-use	174	26	5	24	27	16	67	78	0	0.5	0.5	3.8	12.4	12.4
TOTAL	270	41	8	37	42	28	118	137	0	0.8	0.8	6.6	22.0	22.0

oil is equivalent to about three days (1%) of the world's consumption.

It should be noted when considering these savings, that some geothermal plants do emit limited amounts of the various pollutants; however, these are reduced to near zero where gas injection is used and eliminated where binary power is installed for electric power generation. Since most direct-use projects use only hot water and the spent fluid injected, the above pollutants are essentially eliminated.

CONCLUSIONS

Geothermal growth and development of electricity generation has increased significantly over the past 30 years approaching 15% annually in the early part of this period, and dropping to 3% annually in the last ten years due to an economic slow down in the Far East and the low price of competing fuels. Direct-use has remained fairly steady over the 30-year period at 10% growth annually. The majority of the increase has been due to geothermal heat pumps. At the start of this 30-year period, only ten countries reported electrical production and/or direct utilization from geothermal energy. By the end of this period, 72 countries reported utilizing geothermal energy. This is over a seven-fold increase in participating countries. At least another 10 countries are actively exploring for geothermal resources and should be online by 2010.

Developments in the future will include greater emphases on combined heat and power plants, especially those using lower temperature fluids down to 100°C. This low-temperature cascaded use will improve the economics and efficiency of these systems, such as shown by installations in Germany, Austria and at Chena Hot Springs, Alaska. Also, there is increased interest in agriculture crop drying and refrigeration in tropical climates to preserve products that might normally be wasted. Finally, the largest growth will include the installation and use of geothermal heat pumps, as they can be used anywhere in the world, as shown by the large developments in Switzerland, Sweden, Austria, Germany, Canada, and the United States.

REFERENCES

- Anderson, D.N. and J.W. Lund (Editors), 1979. "Direct Utilization of Geothermal Energy: A Technical Handbook", Special Report No. 7, Geothermal Resources Council, Davis, CA, 250 p.
- Bebout, D.G., Gavenda, V.J., and Gregory, A.R., 1978. "Geothermal Resources, Wilcox Group, Texas Gulf Coast", U.S. Dept. of Energy, contract No.1 EY-76-S-05-4891, 82p.
- Bertani, R., 2005. "World Geothermal General 2001-2005 -- State of the Art." *Geothermics*, Vol 34, No. 6 (Dec.), Elsevier, Amsterdam, Netherlands
- Bertani, R., 2007. "World Geothermal Generation in 2007", *Proceedings European Geothermal Congress*, Unterhaching, Germany, 11 p.
- Cataldi, R., S. Hodgson and J. Lund (editors), 1999. *Stories from a Heated Earth – Our Geothermal Heritage*, Geothermal Resources Council, Davis, CA, 569 p.
- Goddard, W. B. and C. B. Goddard, 1990. "Energy Fuel Sources and Their Contribution to Recent Global Air Pollution Trends." *Geothermal Resources Council Transactions*, v. 14, Davis, CA, pp. 643-649.
- Kagel, A., Bates, D., and K. Gawell, 2005. "A Guide to Geothermal Energy and the Environment," *Geothermal Energy Association*, Washington, D. C., 75 p.
- Lund, J. W. and D. H. Freeston, 2001. "World-Wide Direct Uses of Geothermal Energy 2000." *Geothermics*, v. 30, n.1, Elsevier, Oxford, UK, pp. 29-68 (updated and revised).
- Lund, J. W., D. H. Freeston and T. L. Boyd, 2005a. "World-wide Direct-Uses of Geothermal Energy 2005." *Geothermics*, Vol. 34, No. 6 (Dec.), Elsevier, Amsterdam, Netherlands, pp. 691-727.
- Lund, J. W., Bloomquist, R.G., Boyd, T. L., and J. Renner, 2005b. "The United States of America Country Update – 2005." *Geothermal Resources Council Transactions*, v. 29, Davis, California (CD-ROM), 14 p.
- Lund, J. W. 2006. Chena Hot Springs, *Geo-Heat Center Quarterly Bulletin*, Vol. 27, No. 3 (September), Klamath Falls, OR, pp. 2-4.
- Rybach, L., 2007. "Geothermal Sustainability", *Proceedings European Geothermal Congress*, Unterhaching, Germany, 5 p.
- Tenzer, H., 2001. Development of Hot Dry Rock Technology, *Geo-Heat Center Quarterly Bulletin*, Vol. 22, No. 4, (December), Klamath Falls, OR, pp. 14-22.
- White, D.E., Buffler, L.J.P., and Truesdell, A.H., 1971. "Vapor-Dominated Hydrothermal Systems Compared with Hot-Water Systems", *Economic Geology*, Vol. 66, pp. 75-97.
- White, D. E. and D. L. Williams, Eds., 1975. *Assessment of Geothermal Resources of the United States – 1975*, U.S. Geological Survey Circular 727, U.S., Government Printing Office, 155 p.
- Wright, M., 1998. Nature of Geothermal Resources, in *Geothermal Direct-Use Engineering and Design Guidebook*, edited by John W. Lund, Geo-Heat Center, Klamath Falls, OR, pp. 27-69.