

The Use of Nomenclature in Dispersion Science and Technology

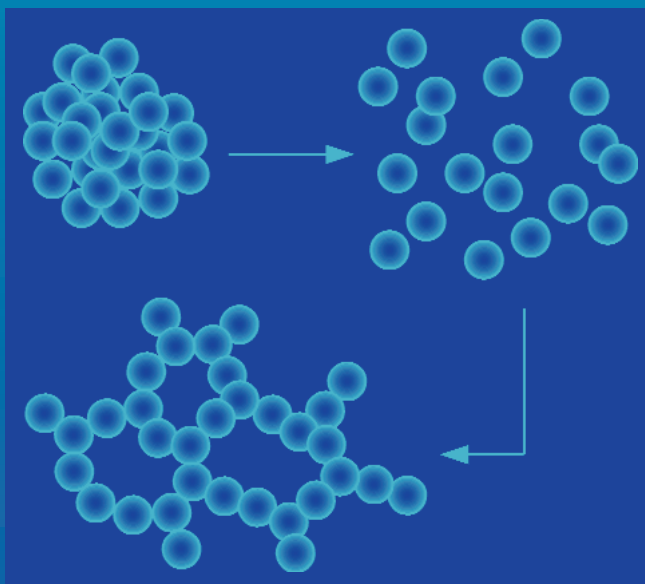

Vincent A. Hackley
Chiara F. Ferraris

NIST
National Institute of
Standards and Technology
Technology Administration
U.S. Department of Commerce

Special
Publication
960-3



Special Publication 960-3

The Use of Nomenclature in Dispersion Science and Technology

Vincent A. Hackley
Materials Science and
Engineering Laboratory

Chiara F. Ferraris
Building & Fire Research Laboratory

Previously issued as NIST
Special Publications 945 and 946

August 2001



U.S. Department of Commerce

Donald L. Evans, Secretary

Technology Administration

Karen H. Brown, Acting Under Secretary of
Commerce for Technology

National Institute of Standards and Technology

Karen H. Brown, Acting Director

Certain commercial entities, equipment, or materials may be identified in this document in order to describe an experimental procedure or concept adequately. Such identification is not intended to imply recommendation or endorsement by the National Institute of Standards and Technology, nor is it intended to imply that the entities, materials, or equipment are necessarily the best available for the purpose.

National Institute of Standards and Technology

Special Publication 960-3

Natl. Inst. Stand. Technol.

Spec. Publ. 960-3

72 pages (August 2001)

CODEN: NSPUE2

U.S. GOVERNMENT PRINTING OFFICE

WASHINGTON: 2001

For sale by the Superintendent of Documents

U.S. Government Printing Office

Internet: bookstore.gpo.gov Phone: (202) 512-1800 Fax: (202) 512-2250

Mail: Stop SSOP, Washington, DC 20402-0001

Foreword

Measurements and standards are universally recognized as playing an integral role in the manufacturing process. They enhance reliability by providing a basis for quantifying and comparing material properties during each phase of manufacturing, from raw materials to the finished product. Equally important is the establishment of a uniform and widely accepted nomenclature for describing experimental methods and instrumentation, for sharing technical ideas and concepts and to provide a sound basis on which to standardize measurement methods and data reporting practices. This is especially true in the ceramics community, due to its cross-disciplinary nature and due to the utilization of ceramic powders throughout numerous industries.

Ceramic suspensions, gels and pastes (i.e., dispersions) are the starting materials for a wide variety of applications, playing critical roles in the processing of products ranging from whitewares, pigments, paper, and cement for the construction industry to multilayer ceramic packages and chemical mechanical planarization slurries for the microelectronics industry. Unfortunately, researchers and engineers working in these diverse fields often speak different languages. Even within the same field, variations in terminology are common. The need for broadly accepted, uniform and precise nomenclature was acknowledged recently by the Ceramic Processing Characterization Consortium (CPCC), a voluntary cooperative organization with participants representing industry, instrument companies, academia and government. A principal goal of the consortium was to develop guidelines and recommended practices for the implementation of process measurements. CPCC members identified nomenclature as a high priority issue in the areas of dispersion and dispersion rheology. As a result, work was initiated on two nomenclature guides, which were ultimately distributed as NIST Special Publications 945 and 946.

The present document is essentially a compilation, with updates, of these two previous publications, and provides guidelines for the use of technical and scientific nomenclature relevant to ceramic dispersions.

Forewordiii
1. Introduction	1
2. Nomenclature for Dispersion Technology	2
2.1 Physical Description of Dispersed Systems	2
2.1.1 Primary Terms	2
2.1.2 Related Terms	3
2.1.3 Recommendations	4
2.2 States of Subdivision (Dispersed Phase)	4
2.2.1 Definitions Based on Size	4
2.2.2 Definitions Based on Structure	5
2.2.3 Related Terms	6
2.2.4 Recommendations	7
2.3 Association and Dissociation Processes	8
2.3.1 Association Processes	8
2.3.2 Dissociation Processes	9
2.3.3 Related Terms	9
2.3.4 Recommendations	10
2.4 Dispersion Stability	10
2.4.1 States of Stability	10
2.4.2 Stability Mechanisms	11
2.4.3 Interaction Terms	11
2.4.4 Related Terms	13
2.4.5 Recommendations	15
2.5 Interfacial and Electrokinetic Properties	15
2.5.1 The Interface	15
2.5.2 Adsorption Processes	16
2.5.3 Electrical Properties	18
2.5.4 Electrokinetic Effects	19
2.5.5 Related Terms	21

◆ Table of Contents

2.6 Bibliography	23
2.6.1 Primary Sources	23
2.6.2 Other Sources	23
Acknowledgements	24
List of Reviewers	24
3. Nomenclature for Rheological Measurements	26
3.1 Fundamental Rheological Properties	26
3.2 Functional Forms of Viscosity	27
3.3 Glossary of Basic Terminology	29
3.4 Classification of Equilibrium Flow Curves	34
3.5 Expressions for Describing Steady Shear Non-Newtonian Flow	35
3.6 Time-Dependent Effects	38
3.7 Oscillatory Measurements	39
3.7.1 Material Functions Derived from Oscillatory Tests	40
3.8 Measurement Apparatus	43
3.8.1 Capillary Methods	43
3.8.2 Rotational Methods	44
3.9 Concrete and Other Coarse-Grained Materials	47
3.9.1 Glossary of Rheological Terms	49
3.9.2 Glossary of Test Methods	50
3.10 Units and Symbols	53
3.10.1 Rheometric Units	53
3.10.2 List of Symbols	54
3.11 Bibliography	56
3.11.1 Primary Sources	56
3.11.2 Other Sources	56
Acknowledgements	57
Ad Hoc Review Committee	58
Index	59

1. INTRODUCTION

The use of nomenclature for describing dispersed particulate systems, along with their associated properties and components, is often inconsistent and subject to misinterpretation in the technical and scientific literature. For example, terms for describing the state of association of particles in suspension (e.g., *aggregate* or *agglomerate*) often carry specific connotations that vary among different authors. This guide has been prepared as a resource for researchers, engineers and students working in dispersion-based applications. In compiling this guide, we drew on a number of resources, including books, review articles and published terminologies. To the extent possible, every effort was made to maintain a degree of uniformity with existing standards and conventions, including published terminologies from the American Concrete Institute (ACI), the British Standards Institute (BSI), the International Union of Pure and Applied Chemistry (IUPAC) and the Society of Rheology, as well as current and draft ASTM and ISO standards.

We intend this guide to serve as a resource for practitioners working in various fields in which ceramic dispersions are used, where *ceramic* is broadly defined as a non-metallic inorganic material. Equations have been used sparingly, and only where necessary for clarity or where they are integral to the subject at hand. This is not, nor is it intended to be, an exhaustive compilation. Rather, this document focuses on commonly encountered terms, and endeavors to provide a consistent framework for improved technical communication.

The technical nomenclature portion of this guide is divided into two sections. The first section is derived from Special Publication 945, and deals with general topics related to dispersion science and technology, such as particle agglomeration and colloidal stability. The second section is based on Special Publication 946, and provides definitions of terms and expressions relating to the measurement of rheological properties in liquid-based ceramic dispersions (i.e., suspensions, pastes and gels).

In addition to the glossaries of basic terms, the guide is organized so that the reader can more readily locate related terms associated with specific subject areas. Defined terms are indicated in boldface type. Where alternative or equivalent terms exist, they are shown in brackets adjacent to the preferred term. Terms used in definitions, and which are defined separately in the guide, are indicated in italic at their first appearance in that paragraph or section. The only exception to this rule is the term viscosity in Part II, which is not italicized when it appears by itself, due to its ubiquity throughout the text.

Descriptions of instrumentation provided in this guide are generic in nature, and are presented solely for the purpose of identifying key measurement techniques and their associated nomenclature.

2. NOMENCLATURE FOR DISPERSION TECHNOLOGY

2.1 Physical Description of Dispersed Systems

2.1.1 Primary Terms

aerosol

Droplets or particles dispersed in a gaseous phase.

continuous phase

Constituting the medium, a phase that exhibits continuity throughout the dispersion; e.g., the liquid in a *suspension*.

dispersed phase [discontinuous phase]

In a *dispersion*, the phase that is distributed in the form of discrete discontinuities (*particles, droplets* or bubbles), in a second immiscible phase that is continuous.

dispersion

In general, a two-phase system in which discontinuities of any kind (solid, liquid, gas) are dispersed in a *continuous phase* of a different composition or state; more specifically in the field of ceramics, the term dispersion is used to describe a *suspension* of solid *particles* in a liquid medium.

emulsion

A *dispersion* consisting of two or more liquid phases.

hydrosol

A *sol* in which water forms the *dispersion* medium.

liquid phase

Consisting of a condensed fluid; e.g., the *dispersion* medium in a *suspension*.

organosol

A *sol* in which an organic liquid forms the *dispersion* medium.

particulate phase [solid phase]

The particles in a *suspension, gel* or *aerosol*.

slip

A term that refers to a *suspension* prepared for the expressed purpose of consolidating the *solid phase* (e.g., by slip-casting, tape-casting or spray drying).

slurry

A concentrated ceramic particulate *suspension*.

sol

A liquid *dispersion* containing particles of *colloidal* dimensions.

suspension

A liquid in which solid particles are dispersed.

2.1.2 Related Terms**heterodisperse**

Describes a *polydisperse* particulate system in which more than one discrete size distribution mode occurs; e.g., bimodal, trimodal, etc.

monodisperse

Realistically, all *dispersions* exhibit a finite spread in their *particle* size distribution. In practice, the term monodisperse can be used to identify a dispersed system in which all particles are of nearly the same size, forming a narrow (unimodal) distribution about an average value. Numerically, a dispersion may be considered monodisperse if 90 % of the distribution (1.645σ , where σ is the standard deviation of the size distribution) lies within ± 5 % of the average size, $\langle d \rangle$:

$$\frac{1.645 \sigma}{\langle d \rangle} \leq 0.05$$

polydisperse

Describes a dispersed system in which many *particle* sizes occur. In practice, a system may be considered polydisperse if less than 90 % of the size distribution (1.645σ , where σ is the standard deviation of the size distribution) lies within ± 5 % of the average size, $\langle d \rangle$:

$$\frac{1.645 \sigma}{\langle d \rangle} > 0.05$$

well-dispersed

A term used to describe a *stable suspension* in which the *minimum particle size* has been achieved.

2.1.3 Recommendations

relative concentration terms

It is recommended that relative descriptive terms relating to particle concentration in *suspension* (e.g., dilute or concentrated) be defined in such a manner that the reader has a clear understanding of their relevance to the measurement or application at hand. For instance, in a light scattering measurement, "dilute" may infer the absence of multiple scattering, whereas in an ultrasonic measurement this term may imply a linear response with concentration. These conditions may vary by several orders of magnitude with respect to particle concentration. Concentration can also be defined on a more fundamental basis, taking into consideration the relative dominance of thermal, hydrodynamic, or surface forces in controlling suspension properties.

2.2 States of Subdivision (Dispersed Phase)

2.2.1 Definitions Based on Size

nanosize [nanophase]

A special state of subdivision implying that the *particles* (or atomic clusters) have average dimensions smaller than roughly 100 nm, and exhibit properties not normally associated with the bulk phase (e.g., quantum optical effects).

colloid

State of subdivision implying that the *particles* have at least in one direction a dimension roughly between 1 nm and 1 μm . Colloids are significantly affected by *Brownian motion* when suspended in a liquid.

ultrafine

State of subdivision implying that the *particles* have in any given direction a maximum dimension lying roughly between 1 μm and 10 μm .

fine [subsieve range]

State of subdivision implying that the *particles* have in any given direction a maximum dimension less than roughly 37 μm .

coarse [sieve range]

State of subdivision implying that the *particles* have in at least one direction a dimension greater than roughly 37 μm .

granule

State of subdivision generally referring to dry particulates with dimensions lying roughly in the 50 μm to 200 μm range; typically, granules are *aggregates* of finer particles produced by spray-drying. Granulation is performed for ease of handling during subsequent consolidation operations.

2.2.2 Definitions Based on Structure**particle**

Any condensed-phase tridimensional discontinuity in a dispersed system may generally be considered a particle; e.g., *droplets* in an *emulsion* or solids dispersed in a liquid. The term is normally used in reference to solid materials. An *aggregate* may also be regarded as a particle.

droplet

Liquid-phase *particle* in an *emulsion* or *aerosol*.

particulate

Composed of distinct *particles*.

primary particle

Smallest identifiable subdivision in a *particulate* system. Primary particles may also be subunits of *aggregates*.

microsphere

Refers to a spherical *particle* in the micrometer size range.

aggregate

A cohesive mass consisting of *particulate* subunits.

hard-aggregate

An *aggregate* that cannot be easily redispersed by the application of moderate mechanical agitation (shaking, stirring, or ultrasonication) and/or mild chemical treatment. Hard-aggregates consist of subunits that have been chemically bonded or *fused*.

agglomerate

In a *suspension*, an *aggregate* held together by physical or electrostatic forces.

coagulate [coagulum]

In a *suspension*, an *aggregate* formed by the addition of electrolyte.

floc

In a *suspension*, an *aggregate* formed by the addition of a polymer. Flocs are generally characterized by a loose structure (low density).

powder

A relatively dry, undispersed accumulation of *particulate* matter with a macroscopic consistency.

gel

Bicontinuous structure with a solid and a liquid component. The solid network may consist of *particles* or polymers, held together by covalent, ionic or dispersion (physical) forces. The network may be elastic, viscoelastic or plastic. The scale of the mesh of the network (distance between cross links) is of *colloidal* dimensions.

aerogel

A porous solid produced from a *gel* in such a way that very little shrinkage occurs. Typically, the term refers to materials made by supercritical extraction of the solvent, although structurally equivalent materials can be made under ambient conditions by increasing network stiffness and/or elastic recovery, and by reducing interfacial tension.

alcogel

A *gel* containing an alcoholic liquid phase.

hydrogel

A *gel* containing an aqueous liquid phase.

xerogel

Porous solid made by drying a *gel* under subcritical conditions.

2.2.3 Related Terms

average agglomeration number (AAN)

An estimate of the degree of *agglomeration* in a *suspension*. AAN is the average number of *primary particles* contained within an *agglomerate*. AAN is calculated from the ratio of the median particle size, as determined by, for example, light scattering, *sedimentation* or electrical zone sensing techniques,

to the average equivalent spherical volume (V_{BET}) given by the BET gas adsorption method, such that:

$$\text{AAN} = \frac{V_{50}}{V_{\text{BET}}} = \left(\frac{D_{50} \cdot \text{SSA} \cdot \rho}{6} \right)^3$$

where V_{50} is the equivalent spherical volume calculated from the median diameter, D_{50} in μm , SSA is the specific surface area in m^2/g and ρ is the particle density in g/cm^3 .

equivalent spherical diameter

The diameter of a sedimenting particle determined from Stokes' law and assuming a spherical shape. The term is sometimes used in conjunction with other measurement techniques and theoretical constructs, where spherical geometry is assumed.

fractal

A structure that has an irregular geometry under all scales of observation (i.e., it is non-Euclidian). The fractal dimension of a species, D_f , is the exponent to which a characteristic length scale must be raised to obtain proportionality with the overall size of the species. Destabilized suspensions tend to form aggregates with fractal structures. In this case, D_f has a value lying between 1 and 3, where $D_f=3$ is a fully dense object.

minimum particle size (MPS)

An experimental quantity operationally defined as the minimum *particle* size that can be achieved by a particular *dispersion* process as determined by an appropriate measurement technique. The characteristic dimension used in determining the MPS should be clearly noted (e.g., mean size, median size, modal size, etc.).

ultimate working unit

An individual *particle* or group of particles that retains its structure throughout a *dispersion* process and subsequent application. See also *minimum particle size*.

2.2.4 Recommendations

floccule

It is recommended that this term not be used in the ceramic literature. (see *floc*)

hard, soft

With the exception of the defined term *hard-aggregate*, it is recommended that such adjectives be avoided in the context of dispersed phase structure. If their use is deemed necessary to convey material-specific information, then the author should make a clear statement that defines the meaning and extent of usage.

2.3 Association and Dissociation Processes

2.3.1 Association Processes

aggregation

A general term defined as any process by which particles collect to form a cohesive mass or cluster; the resulting structure is called an *aggregate*.

agglomeration

Formation of *aggregates* in a *suspension* through physical (van der Waals, hydrophobic) or electrostatic forces. The resulting structure is called an *agglomerate*.

coagulation

A specific type of *agglomeration* in which formation of *aggregates* is induced by the addition of electrolyte to a *suspension*. The resulting structure is termed the *coagulate* or *coagulum*, while the electrolyte additive is termed the *coagulant*.

flocculation

Formation of *aggregates* in a *suspension* mediated by polymeric species, that are either attached to the particles or exist freely in the suspending medium. The resulting structure is called a *floc*, while the polymer additive is termed a *flocculant*. Polymer bridging is a flocculation process.

gelation

Formation of a continuous (space-filling) solid network characterized by a finite static shear modulus (stress/strain ratio); results from percolation of bonds between *particles* or polymers. The resulting structure is termed a *gel*.

fusion

Process by which *particles* form irreversibly bonded structures; often characterized by the appearance of interparticle necks. (see also *hard-aggregates*)

heteroagglomeration, heterocoagulation, heteroflocculation

Generally refers to the *aggregation* of dissimilar particles; in ceramic applications, the formation of *aggregates* by the cohesion between *particles* of different materials (e.g., alumina and silica).

orthokinetic aggregation

The process of aggregation induced by hydrodynamic motions, such as stirring, *sedimentation* or convection.

perikinetic aggregation

The process of *aggregation* induced by *Brownian motion*.

sol-gel

Process for making a *gel* from *colloidal* or molecular precursors.

2.3.2 Dissociation Processes**deagglomeration**

Reversal of *agglomeration*, i.e., the *dispersion* of *agglomerates* to form a *suspension*.

deflocculation

Reversal of *flocculation*, i.e., the *dispersion* of *flocs* to form a *suspension*.

comminution

Breaking down large pieces to the required size; term commonly used in association with milling of ceramic *slurries*.

peptization

Refers to the reversal of *agglomeration* by the addition of a strong acid or strong base, such as HCl or NaOH.

2.3.3 Related Terms**diffusion-limited rate**

Refers to a rate of *aggregation* corresponding to the frequency of encounter (collision rate) of the *particles*. Each collision results in particle adherence (i.e., a sticking probability equal to 1). The rate of encounter is controlled by the diffusion rate, which depends on the viscosity of the medium, the dimensions of the particles, and the concentration of the particles.

reaction-limited rate

Refers to a rate of *aggregation* that is controlled by the reactivity of the *particles* (i.e., the frequency of collisions resulting in particle sticking). Usually characterized by a sticking probability much less than 1. A low sticking probability results from the presence of an energy barrier.

syneresis

Spontaneous shrinking of a *gel* with exudation of liquid.

ultrasonication

Application of high-energy, high-frequency sound to a *suspension* in order to disperse *aggregates*. Dispersion is thought to arise from the energy released during fluid cavitation.

2.3.4 Recommendations

sonication, sonification

It is recommended that these terms not be used in the ceramic literature. (see *ultrasonication*)

2.4 Dispersion Stability

2.4.1 States of Stability

colloidal stability

A physical state that characterizes the relative ability of *colloids* to remain dispersed in a liquid; *suspensions* that do not *aggregate* at a significant rate are said to be colloiddally stable. The precise connotation depends on the time frame under consideration. Colloidal stability is a form of *kinetic stability*, and is therefore considered a metastable thermodynamic state. From this perspective, *aggregation* may be described as a transition from a metastable to a stable state, occurring at rates that depend on the magnitude of the activation energy barrier that separates them.

kinetic stability

Most dispersed systems are thermodynamically unstable, relative to their separate bulk phases; however, a dispersion may exist for an appreciable length of time and therefore exhibit kinetic stability. The term may be used in reference to various destabilizing processes, e.g., *aggregation*, coalescence or *sedimentation*.

stable suspension

A *suspension* that has sufficient *kinetic stability* to prevent the occurrence of significant *aggregation* as measured over a relevant time frame. Stability may be ascertained by suitable experimental means, such as *particle* size, turbidity or *sedimentation* measurements.

unstable suspension

A *suspension* that lacks *kinetic stability* as measured over a relevant time frame; a highly unstable *suspension* is one that is subject to rapid (*diffusion-limited*) *aggregation*.

2.4.2 Stability Mechanisms**electrostatic stabilization**

Mechanism in which *aggregation* is inhibited by the presence of a mutually repulsive electrostatic potential that surrounds each *particle*.

steric stabilization

Mechanism in which *aggregation* is inhibited by the presence of an adsorbed polymer layer that is firmly anchored to the *particle* surface so as not to desorb during collisions. In general, a *steric stabilizing* agent has one portion of its structure that exhibits low solubility in the *dispersion* medium and/or high affinity for the *particle* surface, and the other portion is soluble in the medium.

electrosteric stabilization

Mechanism in which *aggregation* is inhibited by the combined effects of *electrostatic* and *steric stabilization*. Usually associated with the *adsorption* of *polyelectrolytes* onto the *particle* surface.

depletion stabilization

Mechanism in which *aggregation* is inhibited by the presence of free (non-adsorbed) polymer due to the creation of high-energy depletion zones (i.e., depleted of polymer compared to the bulk solution) between closely interacting *particle* surfaces.

2.4.3 Interaction Terms**DLVO**

An abbreviation for a theory of the stability of *colloidal dispersions* describing the pair-wise interaction between charged *particles* in a dielectric medium. The

theory, derived independently by Derjaguin and Landau, and by Verwey and Overbeek, calculates the opposing effects of attractive van der Waals forces and repulsive electrostatic forces on the *interaction potential*.

interaction potential

The potential free energy between two surfaces, typically presented as a function of separation distance. By convention, a positive potential is mutually repulsive and a negative potential is mutually attractive.

primary maximum

The first appearance of a maximum in the *interaction potential energy* curve with increasing separation distance. The primary maximum results from the fact that repulsive and attractive forces decay at different rates as a function of separation distance. In *DLVO* theory, a large primary maximum acts as an energy barrier, preventing *aggregation* of *particles* into the *primary minimum*.

primary minimum

The first appearance of a minimum in the *interaction potential* curve with increasing separation distance. The primary minimum results from the fact that repulsive and attractive forces decay at different rates as a function of separation distance. In *DLVO* theory, a deep (negative) primary minimum acts as an energy well, allowing *particles* to adhere and resulting in a loss of *colloidal stability*.

secondary minimum

A shallow energy minimum (usually of the order of a few kT) in the *interaction potential* curve occurring at relatively large separation distances beyond that of the *primary maximum*. In the presence of such an energy well, secondary minimum *aggregation* may occur. Because of the shallow nature of the secondary minimum, the *aggregates* formed are held together weakly and as such tend to be unstable toward rather small energy inputs such as stirring.

Born repulsion [hard core repulsion]

As two surfaces are brought into close contact, the attractive van der Waals force between them increases continuously. At some point in their approach, the electron clouds of the two surfaces begin to overlap, giving rise to a repulsive force termed the Born or hard core repulsion. This results in a steep increase in the *interaction potential* curve at very small interatomic separation distances, becoming effectively infinite when interpenetration occurs.

solvation [structural] forces

Non-*DLVO* forces that occur at extremely small separation distances (typically

a few molecular diameters) when *particles* interact through an intervening fluid medium. These forces arise whenever liquid molecules are induced to order into quasi-discrete layers between surfaces, and can result in a monotonically increasing (repulsive), monotonically decreasing (attractive) or oscillatory *interaction potential*. In aqueous solvents these forces may be referred to as hydration forces.

Hamaker constant

In the case of *particle* interactions, a material constant that measures the relative strength of the attractive van der Waals forces between two surfaces. Particles interacting through an intervening fluid medium will experience a reduced attractive potential due to the presence of the third component.

hard sphere interaction

A largely theoretical construct in which the *interaction potential* between approaching *particles* is assumed to equal zero, except upon contact where it goes abruptly to infinity (i.e., no interpenetration occurs).

noninteracting

If no barrier to *particle* approach, contact and adherence exists, the *particles* are said to be noninteracting. If the *primary minimum* is sufficiently deep, every *collision* will result in *particles* sticking together. The rate of *aggregation* will then be kinetically controlled (*diffusion-limited rate*).

2.4.4 Related Terms

critical coagulation concentration (CCC)

The molar concentration of electrolyte, C_0 , necessary to induce rapid (*diffusion-limited*) *aggregation*. Experimentally determined by extrapolation of $\ln W$ versus $\ln C_0$ to $\ln W=0$, where W is the *stability ratio*.

coagulant

An electrolyte additive that induces *coagulation* in a *suspension*.

Schulze-Hardy rule

An empirical rule summarizing the general tendency of the *critical coagulation concentration* to vary inversely with the sixth power of the *counter ion* charge number of added electrolyte.

lyotropic series

An ordered series of ions indicating, in decreasing order, their effectiveness in

influencing the behavior of *colloidal dispersions*. Typically associated with an ion's relative propensity to *coagulate a dispersion*.

stability ratio

Ratio of the *diffusion-limited* to *reaction-limited* rate constants for *aggregation*. A large ratio indicates a high degree of *colloidal stability*, whereas a ratio of unity indicates that *diffusion-limited* conditions prevail and the system is *colloidally unstable*. The rate constants are determined experimentally from the initial rates of *aggregation*. Usually denoted by the symbol, *W*.

defoaming agent [antifoaming agent]

A *surfactant* that, when present in small amounts, prevents the formation of a foam or aides in the coalescence of bubbles.

dispersing agent [stabilizing agent, dispersant]

A substance that, when present in small amounts, facilitates the *dispersion* of *aggregates* and improves the *kinetic stability of particles*. For example, *polyelectrolytes* are often used as dispersing agents in *ceramic processing*.

surface active agent [surfactant]

A substance that lowers the interfacial tension between the solution in which it is dissolved, and other phases which are present (e.g., solid *particles* in a *suspension*), and, accordingly, is positively adsorbed at the *interface*.

polyelectrolyte

A macromolecular substance that, on dissolving in water or other ionizing solvent, dissociates to give polyions (polycations or polyanions) - multiple charged ions - together with an equivalent amount of *counter ions*. A *polyelectrolyte* can be a polyacid, a polybase, a polysalt or a polyampholyte. Frequently used as *dispersing agents* in *ceramic slurries*.

sedimentation

The settling of suspended *particles* or *droplets* due to the influence of gravity or an applied centrifugal field.

sedimentation volume

The volume of *particulate* sediment formed in a *suspension*. If the sediment is formed in a centrifugal field, the strength of this field should be explicitly indicated, otherwise normal gravity is understood.

Brownian motion [thermal motion]

Random fluctuations in the density of molecules in a liquid, due to thermal

energy, cause other molecules and small dispersed *particles* to move along random pathways. This random motion is termed Brownian motion, and is most noticeable for *colloidal particles*.

coacervation

When a *colloidal suspension* loses stability, a separation into two liquid phases may occur. This process is termed coacervation. The phase that is more concentrated in the colloid is the coacervate, and the other phase is the equilibrium solution.

2.4.5 Recommendations

deflocculant, dispersing aid

It is recommended that these terms not be used in the ceramic literature. (see *dispersing agent*)

2.5 Interfacial and Electrokinetic Properties

2.5.1 The Interface

interface

A boundary between two immiscible phases, at least one of which is condensed. Experimentally, the portion of the sample through which the first derivative of any concentration versus location plot has a measurable departure from zero. In a *suspension*, the region of contact between the *particle* surface and the suspending medium.

interfacial region [interphase]

The region that exists between two phases where the properties vary from those in the bulk.

surface region

The tridimensional region, extending from the free surface of a condensed phase towards the interior, where the properties differ from the bulk.

electrical double layer (EDL)

The term describes the non-random array of ions at an *interface* in which two oppositely charged layers coexist. For particles dispersed in a fluid, the EDL consists of the surface charge and the solution charge. The solution charge may be further subdivided into *Stern* and *diffuse* layers, which is often referred to as the triple layer model.

double layer thickness

Length characterizing the decrease of potential with distance from a charged *interface*. Typically defined as $1/\kappa$, where κ is the *Debye-Hückel parameter*. For low potentials it represents the distance over which the potential falls to $1/e$ or about one third, of the value of the surface potential.

diffuse layer

The region surrounding a suspended *particle* in which non-specifically adsorbed ions are accumulated and distributed by the opposing action of the electric field and *thermal motion*.

Stern layer [compact layer]

Counter and *co-ions* in immediate contact with a surface are said to reside in the Stern layer, and form with the fixed surface charge a molecular capacitor. Often equated with the immobile portion of the *electrical double-layer* that exists inside the *shear plane*.

inner Helmholtz plane (IHP)

At a charged *interface*, an imaginary plane representing the distance of closest approach of desolvated ions to the surface, and containing the ions or molecules that are specifically adsorbed.

outer Helmholtz plane (OHP)

At a charged interface, an imaginary plane representing the distance of closest approach of solvated (hydrated) ions to the surface. Often equated with the position of the *shear plane*.

shear plane [plane of shear, surface of shear]

In calculating the *electrokinetic potential* from electrokinetic phenomena it is often assumed that a sharp plane separates the liquid adhering to the solid surface from the mobile liquid. This imaginary plane is considered to lie close to the solid surface.

2.5.2 Adsorption Processes

adsorption

The process by which a substance is accumulated at an *interface* or in an *interfacial region*. Should not be confused with absorption, which denotes accumulation inside a material or phase.

adsorbate

A substance that is adsorbed at the *interface* or into the *interfacial region* of a substrate material or *adsorbent*.

adsorbent

The substrate material onto which a substance is adsorbed.

adsorption isotherm

The relationship between the equilibrium quantity of a substance adsorbed and the composition of the bulk phase, at constant temperature.

specific adsorption

Ions are specifically adsorbed when they are present in the *Stern layer* in amounts that exceed those expected from simple electrostatic considerations. Empirically, ions that are specifically adsorbed have a noticeable effect on the *isoelectric point*.

non-specific adsorption

Ions are non-specifically adsorbed when they are kept in the *interphase* only by long-range coulombic interactions. They are believed to retain their solvation shell and in the position of closest approach to the *interface* they are separated from it by one or more solvent molecular layers. Empirically, ions that are non-specific (*indifferent*) have no measurable effect on the value of the *isoelectric point*.

chemical adsorption [chemisorption]

Molecules are chemically adsorbed when they exist within the *Stern layer* and form bonds with the surface groups, which have a significant valence contribution. Empirically, ions that are chemically adsorbed have a noticeable effect on the *isoelectric point* of a *suspension* and exhibit a significant enthalpy (heat of *adsorption*).

physical adsorption [physisorption]

Adsorption in which the forces involved are intermolecular (i.e., van der Waals, hydrogen bonding) of the same kind as those responsible for the non-ideality of real gases and the condensation of vapors, and which do not involve a significant change in the electronic orbital patterns of the species involved.

monolayer adsorption

Adsorption in which only a single layer of molecules becomes adsorbed at an *interface*. In monolayer adsorption, all adsorbed molecules are in the position of closest approach to the substrate surface.

multilayer adsorption

Adsorption in which more than a single layer of molecules is adsorbed at the *interface*. Molecules adsorbed in excess of *monolayer adsorption* are not in the position of closest approach to the substrate surface.

coadsorption

The simultaneous *adsorption* of two or more species.

desorption

The process by which the amount of an adsorbed substance is reduced.

2.5.3 Electrical Properties

isoelectric point (IEP)

For many ceramic systems, the pH at which dispersed *particles* show no *electrophoretic mobility* and the *zeta potential* has a value of zero. More generally, the *pI* value at which zeta is zero, where *I* is the *potential determining ion*.

point of zero charge (PZC)

A *particle* carrying no fixed charge. The precise identification of pzc depends on the definition adopted for surface charge. Typically for *ceramic* systems, the pH at which hydroxyl and proton *adsorption* is just balanced to cancel net charge; here, the hydroxyl and proton are defined as the charge determining species.

surface charge density

The quantity of electrical charge accumulated at a particle-solution *interface*, expressed per unit area; usually represented by the symbol σ_0 .

streaming potential

When a liquid under a pressure gradient is forced through a capillary or porous plug, excess charges (ions) near the wall are swept along by the liquid creating an accumulation of charge downstream. An electric field is also created, which opposes this accumulation. After a steady state has been established, the measured potential difference across the capillary or plug is called the streaming potential and is related to the pressure gradient and to the *shear plane potential*.

zeta potential [electrokinetic potential, shear plane potential]

The potential drop, ζ , across the mobile part of the *electrical double layer*, that is responsible for the *electrokinetic* phenomena. ζ is positive if the potential increases from the bulk of the liquid phase towards the *shear plane*. Certain assumptions or estimations regarding the double layer properties must be made in order to calculate ζ from experimental data. It is therefore essential to indicate in all cases which equations have been used in the calculation of ζ . It can be shown, however, that for the same assumptions about the double

layer properties, all *electrokinetic* phenomena must give the same value for the *electrokinetic* potential.

potential determining ions

Those species of ions that by virtue of their equilibrium distribution between two phases determine the difference in Galvani potential between these phases. They are often, but not always, identical with the ions that stabilize a *colloidal suspension* formed from these phases.

co-ions

In systems containing large ionic species (e.g., *colloids*), co-ions are those that, compared to the large ions, have low molecular mass and the same polarity. For instance, in a *suspension* of negatively charged *particles* containing sodium chloride, the chloride ions are co-ions and the sodium ions are *counterions*.

counterions

In systems containing large ionic species (e.g., *colloids*), counterions are those that, compared to the large ions, have low molecular mass and the opposite polarity. For instance, in a *suspension* of negatively charged *particles* containing sodium chloride, the sodium ions are counterions and the chloride ions are *co-ions*.

charge reversal

The process wherein a charged *particle* is caused to assume a new charge of the opposite polarity. Such a change can be brought about by oxidation, reduction, dissociation, *adsorption* or ion exchange.

2.5.4 Electrokinetic Effects

electrokinetics

Referring to the relative motions of charged species in an electric field. The field may be applied, or it may be created by the motion of a liquid or adjacent solid phase.

electro-osmosis

When a liquid moves in response to an applied electric field, while an adjacent solid phase remains stationary (e.g., in a capillary or porous plug), this is called electro-osmotic flow. Fluid motion is due to the reaction of charged species within the fluid, usually dissolved ions, to the applied field.

electrophoresis

The motion of charged *particles* in an applied electric field.

electrophoretic mobility (static, dynamic)

The *electrophoretic* velocity per unit field strength, symbol $\mu_e=v/E$; μ_e is positive if the *particle* moves toward lower potential and negative in the opposite direction. When measured in a d.c. electric field, μ_e is referred to as the static mobility. When measured in a high-frequency field it is referred to as the dynamic mobility, and given the symbol μ_d or $\mu(\omega)$. Dynamic mobility may be a complex quantity at high frequencies.

electroacoustics

Referring to the electric-acoustic coupling in a fluid containing charged colloids or ions; an effect that is responsible for the *electrokinetic sonic amplitude*, *colloid vibration potential* and *ion vibration potential*.

acoustophoresis

The induced motion of *particles* subjected to an acoustic field. Charged *particles* will generate an electric field as a result of this motion (see *ultrasonic vibration potential*).

ultrasonic vibration potential (UVP)

When a sound wave propagates through a fluid containing charged *particles* (ions or *colloids*), coherent *acoustophoretic* motion of the *particles* creates alternating dipoles that generate a macroscopic potential difference termed the ultrasonic vibration potential.

ion vibration potential (IVP)

The *ultrasonic vibration potential* of an ionic solution; also known as the Debye effect.

colloid vibration current (CVI)

The alternating electrical current generated by the vibration potential of a colloidal suspension. The CVI is related to dynamic mobility of the *particles*; related to *colloid vibration potential*.

colloid vibration potential (CVP)

The *ultrasonic vibration potential* of a *colloidal suspension*. The resulting potential difference is related to the *dynamic mobility* of the *particles*; reciprocal effect to *electrokinetic sonic amplitude*.

electrokinetic sonic amplitude (ESA)

When a high-frequency alternating electric field is applied to a *dispersion* of charged *colloids*, the oscillatory *electrophoretic* motion of the *particles* relative to the surrounding medium results in a measurable acoustic field whose amplitude is related to the *dynamic mobility*; reciprocal effect of *colloid vibration potential*. The phase difference between the applied field and the resulting acoustic response can also be used to estimate the particle size distribution.

2.5.5 Related Terms**amphoteric**

Refers to a type of surface in which the same surface group (reactive site) is able to function as both an acid and a base. That is, the site may dissociate to release a proton or accept a proton.

zwitterionic

Refers to a type of surface in which two distinct surface groups (reactive sites) are present. One is capable of dissociating to release a proton (acid group), and the other is capable of accepting a proton (base group).

hydrophilic

May be used to describe the character of interaction of a particular atomic group (or substance) with an aqueous medium. In this usage the term has the relative qualitative meaning of "water loving." The more general term, lyophilic ("solvent loving"), is used to distinguish a class of colloidal systems.

hydrophobic

The tendency of hydrocarbons (or of lipophilic hydrocarbon-like groups in solutes) to form intermolecular *aggregates* in an aqueous medium, and analogous intramolecular interactions. In this usage the term has the relative qualitative meaning of "water fearing." The more general term, lyophobic ("solvent fearing"), is used to distinguish a class of colloidal systems.

indifferent electrolyte [supporting electrolyte]

An ionic solution, whose constituents are not electroactive (i.e., they have no significant effect on the surface potential of the material under study; no oxidative or reductive capacity) in the range of applied potentials being studied, and whose ionic *strength* (and, therefore, contribution to the conductivity) is usually much larger than the concentration of an electroactive substance to be dissolved in it. The ions constituting an indifferent electrolyte are said to exhibit no specificity for the *particle* surface.

ionic strength

A measure of electrolyte concentration given by $I = \frac{1}{2} \sum c_i z_i^2$, where c_i are the concentrations, in moles per liter, of the individual ions, i , and z_i are their ion charge numbers.

Debye-Hückel parameter

A parameter in the Debye-Hückel theory of electrolyte solutions, denoted as κ . For aqueous solutions at 25 °C, $\kappa = 3.288 \sqrt{I}$ in reciprocal nanometers, where I is the *ionic strength*. See *double layer thickness*.

double layer compression [screening]

Increasing *ionic strength* causes the electrical potential near a charged surface to fall off more rapidly with distance. This is referred to as double layer compression or screening, because the *double layer thickness* shrinks as the *Debye-Hückel parameter* increases with increasing *ionic strength*.

electroviscous effects

For *dispersions* of charged *particles*, these are those components of the viscosity connected with the charge on the *particles*.

suspension effect

The Donnan e.m.f. between a *suspension* and its equilibrium liquid. The effect is most commonly encountered with pH measurements in *colloidal suspensions*.

potentiometric analysis

Analysis based on the measurement of electrical potential using, for example, a pH or ion-selective electrode. Potentiometry is often combined with *titrimetric analysis* in the determination of *particle* surface charge.

titrant

The solution containing the active agent with which a *titration* is made.

titration

The process of determining the amount of a substance A by adding increments of substance B with provision for some means of recognizing the point at which all of A has reacted. This allows the amount of A to be found from the known amount of B added up to this point.

titrimetric analysis

Analysis of test sample properties based on *titration*.

2.6 Bibliography

2.6.1 Primary Sources

Compendium of Chemical Terminology - IUPAC Recommendations, Compiled by V. Gold, K.L. Loening, A.D. McNaught, and P. Sehmi, Blackwell Scientific Publications, Oxford, UK, 1987.

L.L. Schramm, *The Language of Colloid and Interface Science - A Dictionary of Terms*, American Chemical Society, Washington, DC, 1993.

R.J. Hunter, *Foundations of Colloid Science*, Volume 1, Oxford University Press, Oxford, UK, 1989.

P.C. Hiemenz and R. Rajagopalan, *Principles of Colloid and Surface Chemistry*, 3rd Edition, Marcel Dekker, NY, 1997.

G.Y. Onoda and L.L. Hench, "Physical Characterization Terminology," Chapter 5, pp. 35-37 in *Ceramic Processing Before Firing*, Edited by G.Y. Onoda and L.L. Hench, John Wiley & Sons, NY, 1978.

2.6.2 Other Sources

Adsorption of Inorganics at Solid-Liquid Interfaces, Edited by M.A. Anderson and A.J. Rubin, Ann Arbor Science Publishers, Ann Arbor, MI, 1981.

Chemical Processing of Ceramics, Edited by B.I. Lee and E.J.A. Pope, Marcel Dekker, NY, 1994.

Sample Preparation for the Determination of Particle Size Distribution of Ceramic Powders, ISO/DIS 14703, 1998.

Particle Size Analysis: Dispersing Agents for Powders in Liquids, ISO Working Document 14887, 1997.

Surface and Colloid Chemistry in Advanced Ceramics Processing, Edited by R.J. Pugh and L. Bergström, Marcel Dekker, NY, 1994.

Ultrasonic and Dielectric Characterization Techniques for Suspended Particulates, Edited by V.A. Hackley and J. Texter, American Ceramic Society, Westerville, OH, 1998.

C.J. Brinker and G.W. Scherer, *Sol-Gel Science*, Academic Press, NY, 1990.

D.F. Evans and H. Wennerström, *The Colloidal Domain*, VCH Publishers, NY, 1994.

E.K. Fischer, *Colloidal Dispersions*, John Wiley & Sons, NY, 1950.

R.J. Hunter, *Zeta Potential in Colloid Science - Principles and Applications*, Academic Press, NY, 1981.

D. Myers, *Surfaces, Interfaces, and Colloids - Principles and Applications*, Chapter 10, "Colloids and Colloidal Stability," VCH Publishers, NY, 1991.

D.H. Napper, *Polymeric Stabilization of Colloidal Dispersions*, Academic Press, NY, 1983.

R.H. Ottewill, "Stability and Instability in Dispersed Systems," *Journal of Colloid and Interface Science*, 58, 357-373 (1977).

Th.F. Tadros, "Control of the Properties of Suspensions," *Colloids and Surfaces*, 18, 137-173 (1986).

Acknowledgements

A number of terms were included courtesy of the American Chemical Society from the book by L.L. Schramm. Some definitions contained in the Compendium of Chemical Terminology were used, in part or in whole, courtesy of the International Union on Pure and Applied Chemistry.

List of Reviewers

James H. Adair, Merrilea J. Mayo

The Pennsylvania State University, Particulate Materials Center

Jon A. Casey

IBM, Materials Technology

Robert A. Condrate

Alfred University, New York State College of Ceramics

Matthew Frey, William Hunt, Thomas Wood

3M Company, Ceramic Technology Center

George Y. Onoda (retired), **Ajit Jilavenkatesa**

National Institute of Standards and Technology, Ceramics Division

Robert J. Hunter

University of Sydney, School of Chemistry, Australia

George W. Scherer

Princeton University, Department of Chemical Engineering

Ponisseril Somasundaran

Columbia University, Langmuir Center for Colloids and Interfaces

3. NOMENCLATURE FOR RHEOLOGICAL MEASUREMENTS

3.1 Fundamental Rheological Properties

elastic A conservative property in which part of the mechanical energy used to produce *deformation* is stored in the material and recovered on release of *stress*.

electroviscous The collective effects by which the presence of an electrical double-layer influences the *flow* behavior of a liquid. The double-layer is usually associated with charged particles suspended in the liquid or polyelectrolytes dissolved in solution. There are three electroviscous effects:

primary The increase of fluid viscosity due to distortion of the double layer during *shear*. Distortion exerts a drag, increasing energy dissipation.

secondary The increase of fluid viscosity due to the interaction or overlap of adjacent double-layers. Responsible for the formation of gelatin.

tertiary The variation in fluid viscosity that arises from geometrical changes within the fluid due to double-layer interactions. The viscosity of a polyelectrolyte solution depends on the conformation of the molecules, which in turn is affected by intramolecular electrostatic interactions between charged segments located along the polymer backbone or on side chains.

plastic The property of a solid body that is in the *elastic* state when the *stress* is below a critical value, termed the *yield* stress, and in the plastic state when this value is exceeded. During ideal plastic *flow*, energy dissipation and stress are independent of the rate of *deformation*.

viscoelastic A time-dependent property in which a material under *stress* produces both a *viscous* and an *elastic* response. A viscoelastic material will exhibit viscous *flow* under constant stress, but a portion of mechanical energy is conserved and recovered after stress is released. Often associated with polymer solutions, melts and structured suspensions, viscoelastic properties are usually measured as responses to an instantaneously applied or removed constant *stress* or *strain* or a *dynamic* stress or strain.

viscoelectric An effect by which the electric field near a charged interface influences the structure of the surrounding fluid and thereby modifies the viscosity of the fluid.

viscoplastic A hybrid property in which a material behaves like a solid below some critical *stress* value, the *yield stress*, but flows like a viscous liquid when this stress is exceeded. Often associated with highly aggregated suspensions and polymeric gels.

viscous The tendency of a liquid to resist *flow* as a result of internal friction. During viscous flow, mechanical energy is dissipated as heat and the stress that develops depends on the rate of *deformation*.

3.2 Functional Forms of Viscosity

Viscosity nomenclature related to oscillatory measurements is defined here in general terms, but are described more explicitly in section 8.

apparent viscosity, η_{app} The value of viscosity evaluated at some nominal average value of the *shear rate*. The apparent viscosity applies, for instance, in the *capillary method*, where a range of shear rates are employed.

coefficient of fluidity [fluidity], ϕ Reciprocal of the *coefficient of viscosity*.

$$\phi = 1 / \eta$$

coefficient of viscosity [viscosity], η The ratio of *shear stress* to *shear rate* under simple *steady shear*. The abbreviated form "viscosity" is used most often in practice, and is frequently employed without discriminating between Newtonian and non-Newtonian behavior. When the quotient is independent of shear rate (i.e., follows the *Newtonian* model), it is considered a material constant. When the quotient is dependent on shear rate (i.e., *non-Newtonian*), it should be referred to as the **non-Newtonian viscosity**.

$$\eta = \sigma / \dot{\gamma}$$

complex viscosity, η^* The frequency-dependent viscosity function determined during *forced harmonic oscillation of shear stress*; contains both real and imaginary parts.

differential viscosity, η_{diff} The derivative of *shear stress* with respect to *shear rate*.

$$\eta_{\text{diff}} = \partial \sigma / \partial \dot{\gamma}$$

◆ Nomenclature for Rheological Measurements

dynamic viscosity, η' The ratio of the *loss modulus* to the angular frequency, determined during *forced harmonic oscillation* (dynamic) measurements. The real part of the *complex viscosity*.

$$\eta' = G'' / \omega$$

infinite shear viscosity, η_∞ The high *shear rate* limiting value of viscosity. Often associated with the second *Newtonian* region in *pseudoplastic* fluids.

inherent viscosity [logarithmic viscosity], η_{inh} A natural logarithmic function of the *relative viscosity* reduced by the solute concentration.

$$\eta_{inh} = \frac{\ln \eta_r}{c}$$

intrinsic viscosity [limiting viscosity number], $[\eta]$ The zero concentration limiting value of the *reduced specific viscosity*. A characteristic function for the single molecule in solution. $[\eta]$ is equivalent to the effective hydrodynamic specific volume for the solute.

$$[\eta] = \lim_{c \rightarrow 0} \eta_{red}$$

kinematic viscosity, ν The ratio of the viscosity of a fluid to its density.

$$\nu = \eta_s / \rho$$

out-of-phase viscosity, η'' The ratio of the *storage modulus* to the angular frequency, determined during *forced harmonic oscillation* (dynamic) measurements. The imaginary part of the *complex viscosity*.

$$\eta'' = G' / \omega$$

plastic viscosity, η_{pl} For a *Bingham* model, the excess of the *shear stress* over the *yield stress* divided by the *shear rate*, and equal to the *differential viscosity*. For *non-ideal Bingham* materials, the differential viscosity determined in the high-shear limiting, linear portion of the *flow curve*; associated with viscoplastic fluids.

$$\eta_{pl} = \lim_{\dot{\gamma} \rightarrow \infty} \partial \sigma / \partial \dot{\gamma}$$

reduced viscosity [viscosity number], η_{red} The ratio of any viscosity function to the concentration, c , of the solute or particulate phase. By normalizing viscosity in this way, concentration effects become more apparent. For instance, the reduced *specific viscosity* is:

$$\eta_{red} = \eta_{sp} / c$$

relative viscosity [viscosity ratio], η_r Ratio of the viscosity in a suspension or solution to the viscosity of the suspending medium or solvent.

$$\eta_r = \eta / \eta_s$$

specific viscosity, η_{sp} The *relative viscosity* minus unity.

$$\eta_{sp} = \eta_r - 1$$

zero shear viscosity, η_0 The low *shear rate* limiting value of viscosity. Associated with the first *Newtonian* region in many *pseudoplastic* fluids.

$$\eta_0 = \lim_{\dot{\gamma} \rightarrow 0} \eta$$

3.3 Glossary of Basic Terminology

apparent yield stress For non-ideal *viscoplastic* materials, where the *yield stress* is indefinite, an apparent yield stress can be defined, for example, by extrapolation from the linear, high-*shear-rate* portion of the *flow curve* to the stress axis. (see *Bingham* relation)

compliance The quotient of *strain* and *stress* (e.g., *shear compliance*). The reciprocal of *modulus*.

deformation Movement of parts or particles of a material body relative to one another such that the continuity of the body is not destroyed, resulting in a change of shape or volume or both.

dilatant A property often associated with suspensions of irregularly shaped particles, in which the liquid exhibits an increase in volume while being sheared. The term is also used in common practice to mean *shear-thickening*, the increasing resistance to shear with increasing *shear rate*. It is possible for either of these two effects to exist in the absence of the other.

◆ Nomenclature for Rheological Measurements

dynamic equilibrium A state in which dynamic opposing forces just balance to obtain a quasi-equilibrium condition. Dynamic equilibrium is achieved during steady shear flow when break down and rebuilding of *structure* occur at similar rates, and the viscosity is constant at a given *shear rate*.

dynamic [oscillatory] shear flow Condition under which *stress* and *strain* vary harmonically with time during a *rheometric* experiment.

Einstein's Law of Viscosity Describes the relationship between the viscosity of a dilute dispersion and the volume fraction of the dispersed particles. The relationship is derived with two major assumptions, that the particles are solid spheres and that their concentration is very low.

$$\frac{\eta}{\eta_s} = 1 + 2.5\phi + \dots$$

where η_s is the viscosity of the suspending medium and ϕ is the volume fraction. The factor 2.5 is known as the **Einstein coefficient**. To describe more concentrated dispersions, higher terms in the power series have been retained and analyzed with varying success.

equilibrium [steady state] flow Condition under which a constant *stress* or *shear rate* is maintained for a sufficient time to allow *dynamic equilibrium* to be achieved in a fluid containing time-dependent *structure*. An equilibrium *flow curve* can be used to characterize the time-independent *flow* properties of a material.

elastic modulus [modulus of elasticity] A *modulus* of a body that obeys *Hooke's law*.

flow Continuously increasing *deformation* of a material body under the action of finite forces. When the force is removed, if the *strain* does not eventually return to zero, then flow has occurred.

flow curve A graphical representation of the behavior of flowing materials in which *shear stress* is related to *shear rate*.

Hooke's law Provides that the quotient of *stress* and *strain* (i.e., the *modulus*) is a constant. A body obeying Hooke's law cannot be *viscoelastic* nor does *flow* occur.

laminar flow *Flow* without turbulence.

modulus The quotient of *stress* and *strain* where the type of stress and strain is defined by the type of *deformation* employed (e.g., *shear modulus* in shear deformation).

Navier-Stokes equations The equations of motion for a *Newtonian* fluid model describing the balance between external forces (like gravity), the pressure force and the viscous force.

Newtonian *Flow* model of fluids in which a linear relationship exists between *shear stress* and *shear rate*, where the *coefficient of viscosity* is the constant of proportionality.

no-slip Condition in which fluid adjacent to a surface moves with the velocity of that surface. The assumption of no-slip is key to most *rheometric* measurements. Slippage is a significant concern in concentrated suspensions.

non-equilibrium flow Condition under which *shear* is varied at a rate that does not permit *dynamic equilibrium* to be achieved. A *thixotropic loop* is the result of non-equilibrium flow conditions during shear cycling.

non-Newtonian Any *laminar flow* that is not characterized by a linear relationship between *shear stress* and *shear rate*.

normal stress, σ_n The component of stress that acts in a direction normal to the plane of *shear*.

Peclet number, Pe A dimensionless group used to compare the effect of applied shear with the effect of thermal (Brownian) motion; $Pe = r^2 \dot{\gamma} / D$, where r is the particle radius and D is the translational diffusion coefficient. For $Pe \ll 1$, particle behavior is dominated by diffusional relaxation, whereas for $Pe \gg 1$, hydrodynamic effects dominate.

Poiseuille flow *Laminar flow* in a pipe of circular cross section under a constant pressure gradient. (see also *Capillary Methods*)

Reynolds number, Re A dimensionless group that expresses the ratio of the inertial forces to the viscous forces; $Re = Dv\rho/\eta$, where D is a characteristic length (e.g., particle size or pipe diameter), v is a typical fluid speed, and η/ρ is the *kinematic viscosity* of the fluid. The transition from *laminar* to *turbulent flow* is characterized by high Re values.

◆ Nomenclature for Rheological Measurements

rheology The science of the *deformation* and *flow* of matter.

rheometric Refers to the measurement of rheological properties.

shear The relative movement of parallel adjacent layers.

shear compliance, J The ratio of *shear strain* to its corresponding *shear stress*. The reciprocal of *shear modulus*.

shear modulus [modulus of rigidity], G The ratio of *shear stress* to its corresponding *shear strain*. The reciprocal of *shear compliance*.

shear rate (rate of shear strain), $\dot{\gamma}$ The rate of change of *shear strain* with time ($d\gamma/dt$). For liquids, the *shear rate*, rather than *strain*, is generally used in describing *flow*.

shear stress, σ The component of *stress* that causes successive parallel layers of a material body to move, in their own planes (i.e., the plane of *shear*), relative to each other.

shear strain, γ The relative in-plane displacement, Δx , of two parallel layers in a material body divided by their separation distance, y . Alternatively, the shear strain can be defined as $\tan \theta$, where θ is the angle of deformation as shown in Figure 1.

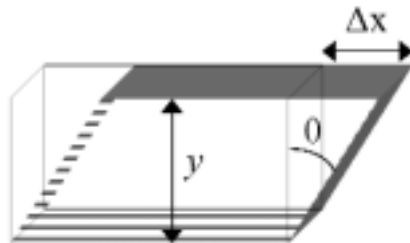

Fig. 1. Shear strain schematic.

shear-thickening An increase in viscosity with increasing *shear rate* during *steady shear flow*. The term *dilatant* is commonly used in practice to indicate shear-thickening, although this usage is strictly incorrect.

shear-thinning [pseudoplastic] A decrease in viscosity with increasing *shear rate* during *steady shear flow*.

simple shear In simple *shear* there is no change in the dimension normal to the plane of shear, and the relative displacement of successive parallel layers of a material body are proportional to their distance from a reference layer. The type of *flow* used in most *rheometric* measurements on fluids can be approximated by simple shear.

steady shear flow Condition under which a fluid is sheared continuously in one direction during the duration of a *rheometric* experiment.

stress Force per unit area.

structure In *rheology*, structure is a term that refers to the formation of stable physical bonds between particles (or chemical bonds between macromolecules) in a fluid. These bonds result in aggregate, floc, or network structure, which impacts the rheological behavior of the fluid and provides *elastic* and *plastic* properties. The term may be extended to include structural effects caused by *electroviscous* interactions, physical bonds between polymers (e.g., associative thickeners), shear-induced alignment of anisotropic particles, and close-packing (radial distribution) correlations in concentrated suspensions. The term "structure" is commonly invoked even when little is known about the cause of observed changes in rheological properties.

Weissenberg effect The tendency of some *viscoelastic* fluids to *flow* in a direction normal to the direction of *shear*. The effect is manifested by behavior such as the climbing of a fluid up a rotating rod.

Weissenberg number, Wi A measure of the degree of nonlinearity or the degree to which *normal stress* differences are exhibited in a *flow*. For *steady, simple shear*, the Weissenberg number is the product of the *shear rate* and a characteristic time of the fluid. In oscillatory shear it is the product of the shear rate amplitude and the characteristic time of the fluid. In converging flows it is proportional to the *Deborah number*.

yield response For non-ideal *viscoplastic* materials, the *yield stress* can be indefinite and yielding may occur continuously over a narrow range of *stress* values. In this case, the behavior may be more properly termed a yield response.

yield stress, σ_y A critical *shear stress* value below which an ideal *plastic* or *viscoplastic* material behaves like a solid (i.e., will not flow). Once the yield stress is exceeded, a plastic material yields (deforms plastically) while a viscoplastic material flows like a liquid.

3.4 Classification of Equilibrium Flow Curves

Steady-shear flow curves for suspensions and solutions measured under equilibrium conditions may exhibit a variety of behaviors over a limited range of *shear rates*. Additionally, some materials may exhibit more than one distinct behavior over different shear rate regions of the same flow curve. Several types of behavior can be classified according to their characteristic shape. The following classification system covers the six most frequently encountered flow types as illustrated in the accompanying graph.

1. **Newtonian** *Differential viscosity and coefficient of viscosity are constant with shear rate.*

2. **shear-thickening** *Differential viscosity and coefficient of viscosity increase continuously with shear rate.*

3. **shear-thinning [pseudoplastic]** *Differential viscosity and coefficient of viscosity decrease continuously with shear rate. No yield value.*

4. **shear thinning [pseudoplastic] with yield response** *Differential viscosity and coefficient of viscosity decrease continuously with shear rate once the apparent yield stress, σ_{app} , has been exceeded.*

5. **Bingham plastic (ideal)** Obeys the *Bingham relation* ideally. Above the Bingham yield stress (σ_B in Figure 2) the *differential viscosity* is constant and is called the *plastic viscosity*, while the *coefficient of viscosity* decreases continuously to some limiting value at infinite *shear rate*.

6. **Bingham plastic (non-ideal)** Above the apparent yield stress the *coefficient of viscosity* decreases continuously, while the *differential viscosity* approaches a constant value with increasing *shear rate*. Extrapolation of the *flow curve* from the linear, high shear rate region (plastic region) to the

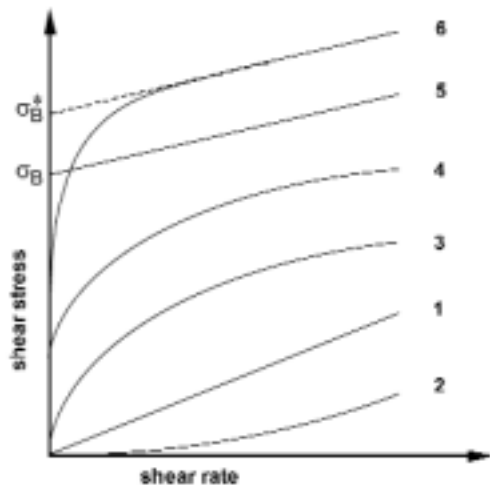

Fig. 2. Identification of flow curves based on their characteristic shape.

stress axis gives the apparent *Bingham* yield stress (σ_B^* in Figure 2). The *differential viscosity* in the linear region is termed the *plastic viscosity*.

3.5 Expressions for Describing Steady Shear Non-Newtonian Flow

The expressions shown in this section are used to characterize the *non-Newtonian* behavior of fluids under equilibrium, *steady shear flow* conditions. Many phenomenological and empirical models have been reported in the literature. Only those having a direct and significant implication for suspensions, gels and pastes have been included here. A brief description of each relationship is given with examples of the types of materials to which it is typically applied. In defining the number of parameters associated with a particular model, the term "parameter" in this case refers to adjustable (arbitrary) constants, and therefore excludes measured quantities. Some of these equations have alternative representations other than the one shown. More detailed descriptions and alternative expressions can be found in the sources listed in the bibliography.

Bingham

$$\begin{aligned}\sigma &= \sigma_B + \eta_{pl} \dot{\gamma} \\ \dot{\gamma} &= 0 \text{ for } \sigma < \sigma_B\end{aligned}$$

The Bingham relation is a two parameter model used for describing *viscoplastic* fluids exhibiting a *yield response*. The ideal Bingham material is an elastic solid at low *shear stress* values and a *Newtonian* fluid above a critical value called the Bingham *yield stress*, σ_B . The *plastic viscosity* region exhibits a linear relationship between shear stress and *shear rate*, with a constant *differential viscosity* equal to the *plastic viscosity*, η_{pl} .

Carreau-Yasuda

$$\frac{\eta - \eta_\infty}{\eta_0 - \eta_\infty} = \left[1 + (\lambda \dot{\gamma})^a \right]^{(n-1)/a}$$

A model that describes *pseudoplastic* flow with asymptotic viscosities at zero (η_0) and infinite (η_∞) *shear rates*, and with no *yield stress*. The parameter λ is a constant with units of time, where $1/\lambda$ is the critical shear rate at which viscosity begins to decrease. The *power-law* slope is $(n-1)$ and the parameter a

◆ Nomenclature for Rheological Measurements

represents the width of the transition region between η_0 and the power-law region. If η_0 and η_∞ are not known independently from experiment, these quantities may be treated as additional adjustable parameters.

Casson

$$\sigma^{1/2} = \sigma_y^{1/2} + \eta_{pl}^{1/2} \dot{\gamma}^{1/2}$$
$$\dot{\gamma} = 0 \text{ for } \sigma < \sigma_y$$

A two parameter model for describing *flow* behavior in *viscoplastic* fluids exhibiting a *yield response*. The parameter σ_y is the *yield stress* and η_{pl} is the differential high shear (*plastic*) viscosity. This equation is of the same form as the *Bingham* relation, such that the exponent is 1/2 for a Casson plastic and 1 for a Bingham plastic.

Cross

$$\frac{\eta - \eta_\infty}{\eta_0 - \eta_\infty} = \frac{1}{(1 + \lambda \dot{\gamma}^m)}$$

A model, similar in form to the *Carreau-Yasuda* relation, that describes *pseudoplastic* flow with asymptotic viscosities at zero (η_0) and infinite (η_∞) *shear rates*, and no *yield stress*. The parameter λ is a constant with units of time, and m is a dimensionless constant with a typical range from 2/3 to 1. If η_0 and η_∞ are not known independently from experiment, these quantities may be treated as additional adjustable parameters.

Ellis

$$\eta = \frac{\eta_0}{1 + \left(\frac{\sigma}{\sigma_2} \right)^{\alpha-1}}$$

A two parameter model, written in terms of *shear stress*, used to represent a *pseudoplastic* material exhibiting a *power-law* relationship between *shear stress* and *shear rate*, with a low shear rate asymptotic viscosity. The parameter σ_2 can be roughly identified as the shear stress value at which η has fallen to half its final asymptotic value.

Herschel-Bulkley

$$\sigma = \sigma_y + k \dot{\gamma}^n$$

A three parameter model used to describe *viscoplastic* materials exhibiting a *yield response* with a *power-law* relationship between *shear stress* and *shear rate* above the *yield stress*, σ_y . A plot of $\log(\sigma - \sigma_y)$ versus $\log \dot{\gamma}$ gives a slope n that differs from unity. The Herschel-Bulkley relation reduces to the equation for a *Bingham* plastic when $n=1$.

Krieger-Dougherty

$$\eta_r = \left(1 - \frac{\Phi}{\Phi_m}\right)^{-[\eta]\Phi_m}$$

A model for describing the effect of particle self-crowding on suspension viscosity, where Φ is the particle volume fraction, Φ_m is a parameter representing the maximum packing fraction and $[\eta]$ is the *intrinsic viscosity*. For ideal spherical particles $[\eta]=2.5$ (i.e., the Einstein coefficient). Non-spherical or highly charged particles will exhibit values for $[\eta]$ exceeding 2.5. The value of $[\eta]$ is also affected by the particle size distribution. The parameter Φ_m is a function of particle shape, particle size distribution and *shear rate*. Both $[\eta]$ and Φ_m may be treated as adjustable model parameters.

The aggregate volume fraction (representing the effective volume occupied by particle aggregates, including entrapped fluid) can be determined using this equation if Φ_m is fixed at a reasonable value (e.g., 0.64 for random close packing or 0.74 for hexagonal close packing) and $[\eta]$ is set to 2.5. In this case, Φ is the adjustable parameter and is equivalent to the aggregate volume fraction.

Meter

$$\eta = \eta_\infty + \frac{\eta_0 - \eta_\infty}{1 + (\sigma/\sigma_2)^{\alpha-1}}$$

A model, expressed in terms of *shear stress*, used to represent a *pseudoplastic* material exhibiting a *power-law* relationship between *shear stress* and *shear rate*, with both high (η_∞) and low (η_0) shear rate asymptotic viscosity limits. The parameter σ_2 can be roughly identified as the shear stress value at which η has fallen to half its final asymptotic value. The Meter and *Carreau-Yasuda* models give equivalent representations in terms of shear stress and shear rate, respectively. If η_0 and η_∞ are not known independently from experiment, these quantities may be treated as additional adjustable parameters.

Powell-Eyring

$$\eta = \eta_{\infty} + (\eta_0 - \eta_{\infty}) \frac{\sinh^{-1}(\tau\dot{\gamma})}{\tau\dot{\gamma}}$$

Derived from the theory of rate processes, this relation is relevant primarily to molecular fluids, but can be used in some cases to describe the *viscous* behavior of polymer solutions and *viscoelastic* suspensions over a wide range of *shear rates*. Here, η_{∞} is the *infinite shear viscosity*, η_0 is the *zero shear viscosity* and the fitting parameter τ represents a characteristic time of the measured system. If η_0 and η_{∞} are not known independently from experiment, these quantities may be treated as additional adjustable parameters.

power-law [Ostwald-de Waele]

$$\sigma = K\dot{\gamma}^n$$

A two parameter model for describing *pseudoplastic* or *shear-thickening* behavior in materials that show a negligible *yield response* and a varying *differential viscosity*. A log-log plot of σ versus $\dot{\gamma}$ gives a slope n (the *power-law* exponent), where $n < 1$ indicates pseudoplastic behavior and $n > 1$ indicates shear-thickening behavior.

3.6 Time-Dependent Effects

Time-dependence includes those effects associated with transient flow conditions as well as those effects associated with irreversible changes that result from shear history.

creep The response of a material to the instantaneous application of a constant stress.

creep function In an applied stress test, where an instantaneous and constant stress is applied to a material while the *shear rate* (or *shear strain*) is measured over time, the shear rate (or strain) vs. time function is termed the *creep* function. The function $J(t) = \gamma(t)/F$ is referred to as the *creep compliance*.

Deborah number, De The ratio of a characteristic *relaxation time* of a material to the duration of the observation. In *equilibrium flow*, the effective duration of the experiment is infinity, and $De = 0$. In oscillatory shear, it is the product of the frequency and the relaxation time of the fluid. In converging flows, the Deborah number is proportional to the *Weissenberg number*.

flow hysteresis A condition resulting from differences in the rate of energy dissipation due to *shear* history. In a typical rheometric test, *shear stress* or *shear rate* is ramped at a fixed speed up to a maximum value, then ramped back down at the same speed to the beginning. In hysteresis, one *flow curve* lies above the other, forming a continuous loop whose internal area depends on the shear and thermal history of the material, and on how rapidly the stress or shear rate was ramped. If the down-curve lies below the up-curve, then it is referred to as a *thixotropic* loop, whereas if the down-curve lies above the up-curve, then it is called a *negative thixotropic* loop.

negative thixotropy [anti-thixotropy] A reversible time-dependent increase in viscosity at a particular shear rate. Shearing causes a gradual growth in *structure* over time.

relaxation time, τ A time characterizing the response of a *viscoelastic* material to the instantaneous application of a constant *strain*.

retardation time, τ A time characterizing the response of a *viscoelastic* material to the instantaneous application of a constant *stress*.

rheomalaxis An irreversible decrease of viscosity during shearing. Attributed to permanent changes in the material *structure*.

rheopexy An effect by which a material recovers some of its pre-sheared viscosity at a faster rate when it is gently sheared compared to when it is allowed to stand. Not to be confused with *negative thixotropy*.

stress growth When an instantaneous and constant *strain* (or *shear rate*) is applied to a material while stress is measured over time, an increasing stress vs. time or *modulus* vs. time function is termed stress growth.

stress relaxation When an instantaneous and constant *strain* (or *shear rate*) is applied to a material while stress is measured over time, a decreasing stress vs. time or *modulus* vs. time function is termed stress relaxation.

thixotropy A reversible time-dependent decrease in viscosity at a particular *shear rate*. Shearing causes a gradual breakdown in *structure* over time.

3.7 Oscillatory Measurements

forced harmonic oscillation is a dynamic *rheometric* test in which both *stress* and *strain* vary harmonically with time, and both *viscous* and *elastic* param-

ters are derived from the material response. Such tests are almost always carried out in the **linear viscoelastic regime**, which is characterized by a linear response of *dynamic viscosity* and *elasticity* with increasing *strain amplitude*.

3.7.1 Material Functions Derived from Oscillatory Tests

In a typical sinusoidal oscillation experiment, the applied stress and resulting *strain* wave forms can be described as follows:

$$\sigma = \sigma_0 \cos \omega t$$

$$\gamma = \gamma_0 \cos(\omega t - \delta)$$

where σ_0 is the **stress amplitude**

γ_0 is the **strain amplitude**

$\omega = 2\pi f$ is the angular frequency

t is time

δ is the **phase lag (loss angle)**

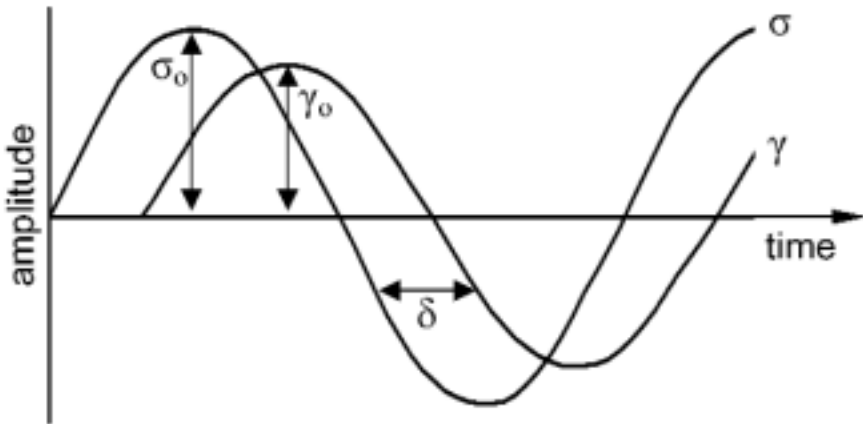

Fig. 3. Sinusoidal wave forms for stress and strain functions.

The phase lag and amplitude ratio (σ_0/γ_0) will generally vary with frequency, but are considered material properties under linear *viscoelastic* conditions. For an ideal solid, $\delta=0^\circ$, and the response is purely *elastic*, whereas for a *Newtonian* fluid yielding a purely viscous response, $\delta=90^\circ$.

The material functions can be described in terms of complex variables having both real and imaginary parts. Thus, using the relationship:

$$\cos x + j \sin x = e^{jx}$$

$$\text{where } j = \sqrt{-1}$$

Then the stress and strain can be expressed as follows:

$$\sigma = \Re(\sigma_0 e^{j\omega t})$$

$$\gamma = \Re(\gamma_0 e^{j(\omega t - \delta)}) = \Re(\gamma_0 e^{-j\delta} e^{j\omega t})$$

where $(\gamma_0 e^{-j\delta})$ is termed the complex strain amplitude. The **shear storage modulus** [or storage modulus, for short], which represents the in-phase (elastic) component of oscillatory flow, is defined as:

$$G' = \text{storage modulus} = \frac{\sigma_0}{\gamma_0} \cos \delta$$

The out-of-phase (viscous) component is termed the **shear loss modulus** [or loss modulus, for short]:

$$G'' = \text{loss modulus} = \frac{\sigma_0}{\gamma_0} \sin \delta$$

The **complex shear modulus**, G^* , is then defined as follows:

$$G^* = \frac{\text{complex stress amplitude}}{\text{complex strain amplitude}} = \frac{\sigma_0}{\gamma_0} \cos \delta + \frac{\sigma_0}{\gamma_0} j \sin \delta$$

so that:

$$G^* = G' + jG''$$

$$\tan \delta = G''/G'$$

The function G''/G' measures the relative importance of viscous to elastic contributions for a material at a given frequency.

Additionally, a *complex viscosity*, η^* , can be defined using the complex strain rate, $\dot{\gamma} = j\omega\gamma$, such that:

$$\eta^* = \frac{\text{complex stress amplitude}}{\text{complex strain rate amplitude}} = \frac{\sigma_0}{j\gamma_0\omega} e^{j\delta} = \frac{G^*}{j\omega}$$

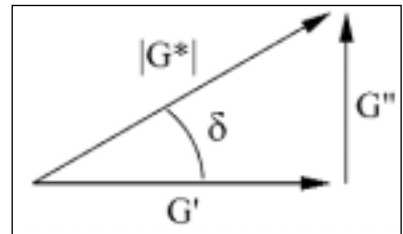

Fig. 4. Vectorial representation of moduli.

or alternatively

$$\eta^* = \eta' - j\eta''$$

$$\eta' = G''/\omega$$

$$\eta'' = G'/\omega$$

where η' is termed the *dynamic viscosity*, and is equivalent to the ratio of the stress in phase with the rate of strain ($\sigma_0 \sin \delta$) to the amplitude of the rate of strain ($\omega\gamma_0$). The term η'' is referred to as the *out-of-phase viscosity*, and is equivalent to the ratio of the stress 90° out of phase with the rate of strain ($\sigma_0 \cos \delta$) to the amplitude of the rate of strain ($\omega\gamma_0$) in the forced oscillation.

Finally, an **absolute shear modulus** is defined as the ratio of the amplitude of the stress to the amplitude of the strain in forced oscillation (*simple shear*), or:

$$|G^*| = \frac{\sigma_0}{\gamma_0} = (G'^2 + G''^2)^{1/2}$$

Alternatively, forced oscillation experiments can be equivalently described in terms of *compliance*, as opposed to the derivation above based on the modulus. Similar arguments lead to the following analogous terms:

complex shear compliance, J^* The ratio of the complex strain (γ^*) to complex stress (σ^*) in forced oscillation (simple shear).

shear storage compliance, J' The ratio of the amplitude of the strain in phase with the stress ($\gamma_0 \cos \delta$) to the amplitude of the stress (σ_0) in forced oscillation (simple shear).

shear loss compliance, J'' The ratio of the amplitude of the strain 90° out of phase with the stress ($\gamma_0 \sin \delta$) to the amplitude of the stress (σ_0) in forced oscillation (simple shear).

absolute shear compliance, $|J^*|$ The ratio of the amplitude of the strain (γ_0) to the amplitude of the stress (σ_0) in forced oscillation (simple shear).

3.8 Measurement Apparatus

There are two common methods used for *rheometric* measurements on fluid systems: capillary (or tube) and rotational. In this section, a brief summary is given for each general method along with descriptions of common measurement devices and geometries. Measurement devices can be grouped into one of two general classifications. A **viscometer** is a device used principally for the measurement of viscosity, while a **rheometer** is a device used for the measurement of rheological properties over a varied and extended range of conditions. More detailed descriptions of these instruments and methods can be found in the primary sources listed in the bibliography. Only a brief coverage is provided here.

3.8.1 Capillary Methods

In capillary methods the test fluid is made to flow through a narrow tube as a result of hydrostatic or applied pressure. Capillary measurements are considered the most precise way of determining the viscosity of *Newtonian* and some *non-Newtonian* viscous fluids, and are generally simpler in design and less expensive relative to *rotational* instruments. **Poiseuille's Law**, which relates the rate of flow through a capillary to the viscosity of the liquid, is the basis for the capillary method.

Glass Capillary Viscometer

Widely used for measuring the viscosity of *Newtonian* fluids, including dilute solutions and suspensions, the glass capillary viscometer is the simplest and least expensive viscometric system available commercially. Typically, in this technique, the time required for a given volume of fluid to flow through a defined length, L , of glass capillary under its own hydrostatic head is measured. The flow time, t , is related to the viscosity using a simple relationship derived from Poiseuille's Law, of the form:

$$\frac{\eta}{\rho} = At + \frac{B}{t}$$

Fig. 5. Ostwald type capillary viscometer. A and B are timing marks, C is a filling mark.

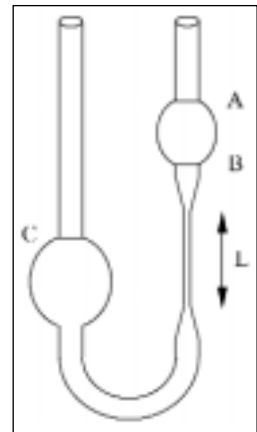

◆ Nomenclature for Rheological Measurements

where A and B are instrument constants. The second term on the right hand side is related to the kinetic energy correction, and can be ignored for long flow times. In this case, a simple linear equation results. The viscometer can be easily calibrated using a standard fluid with known viscosity at the measurement temperature. Capillaries with different diameters can be used for different viscosity ranges, while maintaining reasonable flow times.

Extrusion Capillary Viscometer

These instruments are widely used for measuring viscous fluids, such as asphalt cements, polymer melts, and stable concentrated suspensions. Extrusion viscometers have the advantage of high precision and simple design, and are less subject to temperature effects that can occur during shearing of highly viscous fluids in *rotational* devices.

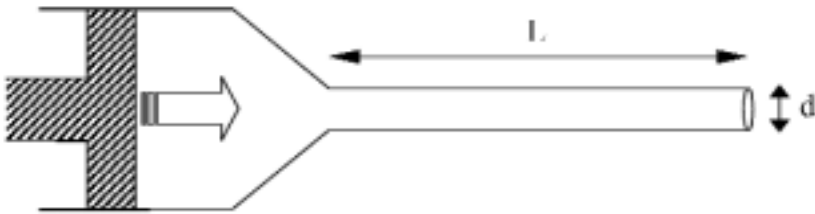

Fig. 6. Diagram of a simple extrusion viscometer.

Extrusion viscometers use a cylindrical piston to force the test fluid from a reservoir through the capillary tube at a constant velocity. By measuring the pressure drop across the capillary as a function of flow rate for multiple capillaries of the same diameter, d , but differing length, L , it is possible to determine the viscosity as a function of *shear rate*.

3.8.2 Rotational Methods

In rotational methods the test fluid is continuously sheared between two surfaces, one or both of which are rotating. These devices have the advantage of being able to *shear* the sample for an unlimited period of time, permitting transient behavior to be monitored or an equilibrium state to be achieved, under controlled *rheometric* conditions. Rotational methods can also incorporate *oscillatory* and *normal stress* tests for characterizing the *viscoelastic* properties of samples. In general, rotational methods are better suited for the measurement of concentrated suspensions, gels and pastes, but are generally less precise as compared to *capillary* methods.

Rotational measurements fall into one of two categories: **stress-controlled** or **rate-controlled**. In stress-controlled measurements, a constant torque is applied to the measuring tool in order to generate rotation, and the resulting rotation speed is then determined. If a well-defined tool geometry is used, the rotation speed can be converted into a corresponding *shear rate*. In rate-controlled measurements, a constant rotation speed is maintained and the resulting torque generated by the sample is determined using a suitable stress-sensing device, such as a torsion spring or strain gauge. Some commercial instruments have the capability of operating in either stress-controlled or rate-controlled modes.

Simple Rotational Viscometer ("Brookfield type")

The least expensive commercial variant of the controlled-rate rotational *viscometer* is commonly referred to as a "Brookfield type" viscometer§. This device measures fluid viscosity at fixed rotation speeds by driving a measurement tool ("spindle"), immersed in the test fluid, through a calibrated torsion spring. Viscous drag of the fluid against the spindle causes the spring to deflect, and this deflection is correlated with torque. The calculated *shear rate* depends on the rotation speed, the tool geometry and the size and shape of the sample container. Conversion factors are needed to calculate viscosity from the measured torque, and are typically pre-calibrated for specific tool and container geometries. For *Newtonian* fluids the torque is proportional to the product of viscosity and rotational speed, but this proportionality is lost in the case of a *non-Newtonian* fluid. Because these instruments are robust and fairly simple to use, they have found wide application in industry, but they offer limited capabilities and precision for research-oriented applications.

Rotational Rheometer

High-precision, continuously-variable-*shear* instruments in which the test fluid is sheared between rotating cylinders, cones or plates, under controlled-stress or controlled-rate conditions, are termed rotational rheometers. Instruments producing *oscillatory* strains are available, and a few commercial

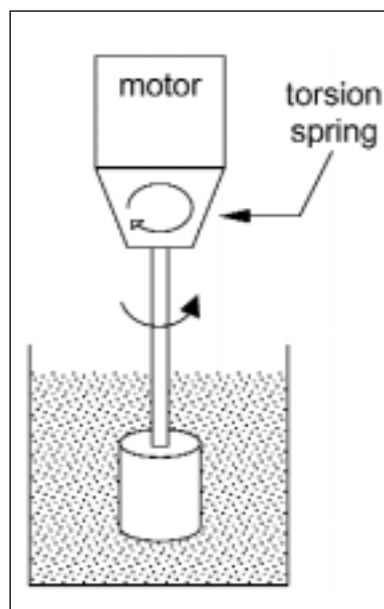

Fig. 7. Schematic diagram of a Brookfield-type viscometer.

◆ Nomenclature for Rheological Measurements

systems permit measurement of the *normal stress*. The basic rotational system consists of four parts: (i) a measurement tool with a well-defined geometry, (ii) a device to apply a constant torque or rotation speed to the tool over a wide range of *shear stress* or *shear rate* values, (iii) a device to determine the stress or shear rate response, and (iv) some means of temperature control for the test fluid and tool. Depending on the design specifications, rheometers may also include built-in corrections or compensations for inertia, drift, and temperature fluctuations during measurement.

Most rheometers are based on the relative rotation about a common axis of one of three tool geometries: concentric cylinder, cone and plate or parallel plates (See Figure 8).

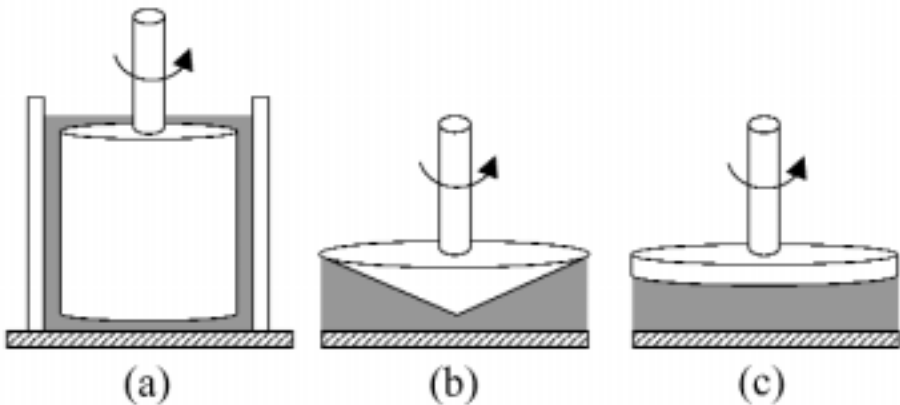

Fig. 8. Schematic diagram of basic tool geometries for the rotational rheometer: (a) concentric cylinder, (b) cone and plate, (c) parallel plate.

In the **concentric cylinder** (also called **Couette** or **Coaxial**) geometry either the inner, outer or both cylinders may rotate, depending on instrument design. The test fluid is maintained in the annulus between the cylinder surfaces. This tool geometry comes in several configurations, of which the three most commonly encountered are illustrated in Figure 9. The **double-gap** configuration is useful for low viscosity fluids, as it increases the total area, and therefore the viscous drag, on the rotating inner cylinder, and generally increases the accuracy of the measurement. The **cone** and **hollow cavity** configurations are specifically designed to reduce or account for end effects. In addition, to prevent slippage, the inner cylinder surface is sometimes serrated or otherwise

roughened. The concentric cylinder geometry is typically used for the analysis of fluid suspensions.

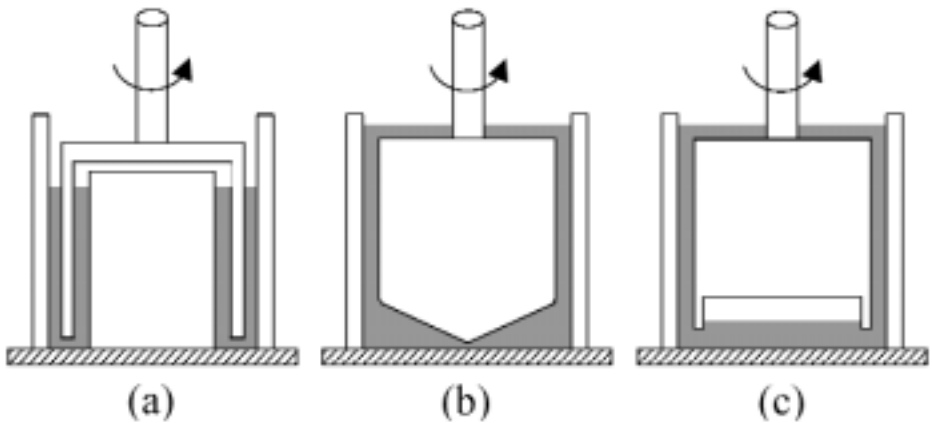

Fig. 9. Schematic diagram showing three alternative cylindrical tool designs in cut-away view: (a) double gap, (b) cone and plate at the bottom, (c) hollow cavity at the bottom to trap air.

The **cone and plate geometry** consists of an inverted cone in near contact with a lower plate. The cone is usually designed with an angle of less than 4° . Either the upper or lower surface may rotate depending on instrument design. The **parallel plate geometry** can be considered a simplified version of the cone and plate, having an angle of 0° . The test fluid is constrained in the narrow gap between the two surfaces. Cone and plate and parallel plate measurement tools are most often used for highly viscous pastes, gels, and concentrated suspensions.

3.9 Concrete and Other Coarse-Grained Materials

Ceramic materials are typically fabricated from particles in the subsieve or fine size range (i.e., less than roughly $37\ \mu\text{m}$), though coarse agglomerates may play a role during some phase of processing. On the other hand, concrete is classified as a ceramic material, but containing a considerably broader range of particle sizes, from less than one micrometer up to about 20 mm (i.e., well into the sieve range). This wide range results from the heterogeneous concrete composition, which includes cement ($5\ \mu\text{m}$ to $60\ \mu\text{m}$), mineral fillers ($< 1\ \mu\text{m}$ to $100\ \mu\text{m}$), fine aggregates (0.1 mm to 5 mm) and coarse aggregates (4 mm to 30 mm or higher in some special concretes) or stones.

As a result of the broad range of particle sizes and the presence of sieve-size particles, methods to measure the *flow* properties of concrete differ significantly from those methods specified for applications involving suspensions of fine particles. Test methods applied to concrete tend to be largely empirical in nature or they are scaled up versions of the techniques described in section 9 for fine particle suspensions. In the former case are the most commonly used tests in the industry; they generally represent an attempt to "imitate" a mode of placement or flow of the concrete during production. In the latter case are less common methods that attempt to measure fundamental rheological properties of concrete. In addition, rheological test methods for concrete tend to fall into one of four general categories:

confined flow The material flows under its own weight or under an applied pressure through a narrow orifice. The orifice is defined as an opening roughly three to five times larger than the maximum particle size. Because coarse aggregates are often of the order of 30 mm, the orifice must typically be 90 mm to 150 mm in diameter. Confined flow methods include *flow cone*, *filling ability* devices, *flow test* through an opening and the *Orimet apparatus*.

free flow The material either flows under its own weight, without any confinement or an object penetrates the material by gravitational settling. Free flow methods include *slump*, *modified slump*, *penetrating rod* and *turning tube viscometer*.

vibration The material flows under the influence of applied vibration. The vibration is applied by using a vibrating table (e.g., Ve-Be time and remolding test), dropping the base supporting the material (*DIN slump cone test*), an external vibrator (e.g., *LCL apparatus*) or an internal vibrator (e.g., *settling method*).

rotational rheometers The material is sheared between two parallel surfaces, one or both of which are rotating. These tests are analogous to rheometers described in section 9, except in this case the gap between surfaces must be scaled up to reflect the much larger dimensions of the concrete particles. Rotational rheometers include *BTRHEOM*, *CEMAGREF*, *two-point* or *Tattersall*, *IBB*, and *BML*.

Separate glossaries of rheological terms and test methods are provided below. For more detailed summaries of the numerous rheological tests used throughout the concrete industry, including empirical tests that are widely implemented, see Ferraris (1999) in the list of primary sources.

3.9.1 Glossary of Rheological Terms

Much of the rheological work on concrete and other cementitious materials has, historically, been directed toward the practical exploitation of the material and, as a result, numerous terms are in common use that are unique to the concrete, mortar and cement industries. The most frequently encountered rheological terms are defined here.

consistency The relative *mobility* or ability of freshly mixed concrete or mortar to *flow*; the usual measurements are *slump* for concrete, flow for mortar or grout, and penetration resistance for neat cement paste. (see: *normal consistency*, *plastic consistency*, *wettest stable consistency*)

consistency factor A measure of grout *fluidity*, roughly analogous to viscosity, that describes the ease with which grout may be pumped into pores or fissures; usually a laboratory measurement in which *consistency* is reported in degrees of rotation of a torque viscometer in a specimen of grout.

consolidation The process of inducing a closer arrangement of the solid particles in freshly mixed concrete or mortar, during and after placement until setting, by the reduction of voids. Consolidation is accomplished by vibration, centrifugation, rodding, tamping or some combination of these actions. This term is also applicable to similar manipulation of other cementitious mixtures, soils, aggregates or the like.

finishing Leveling, smoothing, consolidating and otherwise treating the surfaces of fresh or recently placed concrete or mortar to produce the desired appearance and service.

impending slough *Consistency* of a shotcrete mixture containing the maximum amount of water such that the product will not *flow* or sag after placement.

mobility The ability of fresh mixed concrete or mortar to *flow*.

normal consistency (1) The degree of wetness exhibited by a freshly mixed concrete, mortar, or neat cement grout when the *workability* of the mixture is considered acceptable for the purpose at hand. (2) The physical condition of neat cement paste as determined with the *Vicat apparatus* in accordance with a standard test method (e.g., ASTM C 187).

◆ Nomenclature for Rheological Measurements

plastic consistency Condition of freshly mixed cement paste, mortar or concrete such that *deformation* will be sustained continuously in any direction without rupture.

slump A measure of *consistency* of freshly mixed concrete, mortar or stucco equal to the subsidence measured to the nearest 5 mm (1/4 in) of the molded specimen after removal of the *slump cone*.

wettest stable consistency The condition of maximum water content at which cement grout and mortar will adhere to a vertical surface without sloughing.

workability [placeability] That property of freshly mixed concrete or mortar that determines the ease and homogeneity with which it can be mixed, placed, consolidated and finished.

3.9.2 Glossary of Test Methods

BML Commercial *rotational rheometer* derived from the *two-point test*. The principle of operation is identical to the two-point test, but the shape of the vane has been modified. The vane is as shown in Figure 10(c).

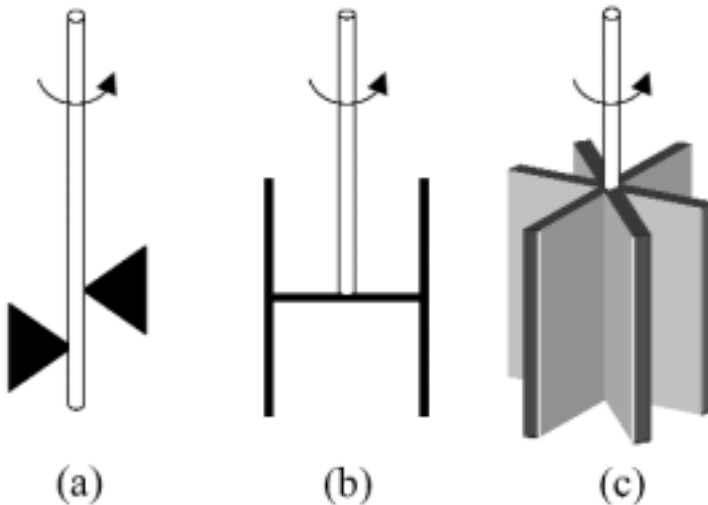

Fig. 10. Various vane geometries used in concrete rheometers: (a) two-point test or Tattersall, (b) IBB, (c) BML.

BTRHEOM Commercial *parallel plate concrete rheometer*. Measurements can be performed with and without applied vibration.

CEMAGREF Coaxial *rotational rheometer* originally developed for testing fluid lava. It has been occasionally employed to test concrete. Only one prototype currently exists.

DIN slump cone test A vibration method. A variation of the *slump cone test* in which the cone is placed on a metal sheet. After filling the cone with concrete, it is lifted and the metal support sheet is raised on one side and dropped from a pre-established height (usually about 100 mm) a specified number of times. The spread of the concrete is measured. This standard test is described in DIN 1045.

filling ability *Confined flow method* measuring the ability of concrete to *flow* into a predefined form. Several different molds are used: U-shaped and L-shaped are the most common. In both cases the concrete is forced by gravity to flow into and fill the mold. The volume occupied by the concrete at the end of the test is a measure of the ability of the concrete to flow or its filling ability.

flow cone [V-funnel cone] *Confined flow method* consisting in filling a funnel with concrete or cement paste and determining the time for the material to *flow* out through the orifice. This time is a measure of the material's ability to flow. There are several types of funnel, some with round and others with parallel piped orifice and upper opening.

flow test Used in accordance with ASTM C1362. This test measures the *flow* of concrete or mortar into a perforated tube. This method is applicable for concrete with coarse aggregates less than 37.5 mm in diameter. The instrument consists of a hollow perforated tube that is inserted in the concrete sample, after which the material is allowed to flow into the hollow tube. The height of the concrete in the hollow tube is considered a measure of the *consistency* of the concrete.

IBB Commercially available *rotational rheometer*. It is derived from the *two-point test*. The principle of operation is identical, but the vane shape has been modified, and the vane moves in a planetary motion and on its axis. The vane is shaped like the letter H and is shown in Figure 10(b).

LCL apparatus A *vibration method*. The concrete is poured behind a gate in a large parallel piped container. The gate is opened and the vibrator is turned

on. The time for the concrete to *flow* and occupy the whole container is measured. A longer time suggests a lower ability of the concrete to flow.

modified slump test Modification of the *slump test* described in ASTM C143. It permits the measurement of the rate at which the concrete is slumping, which gives an estimate of the concrete *plastic viscosity*. This test was developed at NIST, but is not currently a standard method (see Ferraris (1999) in primary sources).

Orimet apparatus *Confined flow method* instrument consisting of a tube 600 mm in length that is closed at the bottom by a removable trap door. The time for the concrete to *flow* through the tube once the trap is released is determined. This time is a measure of the ability of concrete to flow.

penetrating rod *Free flow method* measuring the distance a rod of fixed mass can penetrate a concrete sample. It is a crude determination of whether the *yield stress* of the concrete is higher or lower than a predefined value. It is used to monitor concrete at the job site. A specific application of this test is the *Vicat apparatus*.

settling method [Fritsch test] A *vibration method*, this test measures the capability of concrete to *consolidate* under vibration. Concrete is placed in a container with an internal vibrator. The time to obtain full consolidation is measured. The full consolidation is determined when the surface of the concrete no longer moves.

slump cone test *Free flow method* in which a truncated metal cone, open at both ends and sitting on a horizontal surface, is filled with concrete and lifted gradually. The *slump* of the concrete is measured. This standard test is described in ASTM C143.

turning tube viscometer *Free flow method* consisting of a tube 60 mm in diameter and 800 mm long that can be filled with cement paste or mortar. A ball is dropped into the fluid and its velocity is measured between two points 370 mm apart. Using the Stokes equation, the viscosity can be calculated.

two-point test [Tattersall rheometer] First commercially available *rotational rheometer* for concrete. It is the first attempt to *shear* concrete at different rates and to measure the induced *stress*. It consists of a bucket filled with concrete and a vane, shown in Figure 10(a), that rotates at controlled speeds. The torque generated during rotation is measured.

Ve-Be time [remolding test] Measures the ability of concrete to change shape under vibration. Concrete is placed in a *slump cone*. After the cone is lifted away, the time it takes for the concrete to remold itself into a cylinder while under vibration is measured.

Vicat apparatus A *free flow method*, the Vicat apparatus is a penetration device used in the testing of hydraulic cements and similar materials. The full description of this instrument and the correct procedure to determine the *normal consistency* of cement is described in ASTM C187.

3.10 Units and Symbols

3.10.1 Rheometric Units

All units should conform to the International System of Units (SI) as defined by the National Institute of Standards and Technology.¹ The use of CGS and other non-SI units is discouraged. For convenience, SI units are shown in Table 1 in association with their common non-SI equivalents (including decimal submultiples and conversion factors where appropriate). Table 2 shows the SI-derived units with their underlying base units.

Table 1. SI and equivalent rheometric units.

Quantity	SI Units	Equivalent CGS Units
viscosity	Pa · s	10 P (poise) or 1000 cP (centipoise)
kinematic viscosity	m ² · s ⁻¹	10 ⁴ St (stoke) or 10 ⁶ cSt (centistoke)
shear stress	Pa	0.1 dyn · cm ⁻²
strain	unitless	
shear rate	s ⁻¹	s ⁻¹
modulus	Pa	0.1 dyn · cm ⁻²
compliance	Pa ⁻¹	10 cm ² · dyn ⁻¹
frequency	Hz	
angular frequency	2πf	
phase angle	rad	

¹ B.N. Taylor, *Guide for the Use of the International System of Units (SI)*, NIST Special Publication 811, 2nd Edition, National Institute of Standards and Technology, U.S. Government Printing Office, Washington, DC, 1995.

Table 2. SI derived units expressed in terms of SI base units.

Symbol	Special Name	Other SI Units	SI Base Units
Pa	Pascal	$\text{N} \cdot \text{m}^{-2}$	$\text{kg} \cdot \text{m}^{-1} \cdot \text{s}^{-2}$
Hz	Hertz		s^{-1}
rad	radian		$\text{m} \cdot \text{m}^{-1} = 1$

3.10.2 List of Symbols

σ	shear stress
σ_n	normal stress
σ_y	yield stress
γ	strain
$\dot{\gamma}$	shear rate [rate of shear strain]
De	Deborah number
Pe	Peclet number
Re	Reynolds number
η	coefficient of viscosity [viscosity]
η_{app}	apparent viscosity
η_{diff}	differential viscosity
η_{∞}	infinite shear viscosity
η_{inh}	inherent viscosity
$[\eta]$	intrinsic viscosity
η_{red}	reduced viscosity
η_r	relative viscosity
η_s	viscosity of suspending medium or solvent
η_{sp}	specific viscosity
η_0	zero shear viscosity
ν	kinematic viscosity
ϕ	fluidity
G	shear modulus
G^*	complex shear modulus
G'	shear storage modulus
G''	shear loss modulus
$ G^* $	absolute shear modulus
η^*	complex viscosity
η'	dynamic viscosity (real component of the complex viscosity)
η''	imaginary component of the complex viscosity

J	shear compliance
J^*	complex shear compliance
J'	shear storage compliance
J''	shear loss compliance
$ J^* $	absolute shear compliance
τ	relaxation time, retardation time
σ_0	stress amplitude
γ_0	strain amplitude
δ	phase angle
ω	angular frequency
f	frequency

3.11 Bibliography

This bibliography cites sources used in the compilation of this guide. It is not, nor is it intended to be, an exhaustive list of references available on the vast subject of rheology or rheological instrumentation. Nevertheless, it may serve as a good starting point for those who are relatively new to this field or searching for relatively fundamental information.

3.11.1 Primary Sources

American Concrete Institute, *Cement and Concrete Terminology*, ACI 116R-90, ACI Manual of Concrete Practice 2000, Part 1, Farmington Hills, MI.

British Standards Institution, *Glossary of Rheological Terms*, BS 5168:1975.

A.A. Collyer and D.W. Clegg, Editors, *Rheological Measurement*, Chapman and Hall, London, 1998.

J.M. Dealy, "Official Nomenclature for Material Functions Describing the Response of a Viscoelastic Fluid to Various Shearing and Extensional Deformations," *Journal of Rheology*, **39**[1], 253-265 (1995).

C.F. Ferraris, "Measurement of the Rheological Properties of High Performance Concrete: State of the Art Report," *Journal of Research of the National Institute of Standards and Technology*, **104**[5], 461-478 (1999).

A. Kaye, R.F.T. Stepto, W.J. Work, J.V. Alemán and A.Ya. Malkin, "Definition of Terms Relating to the Non-Ultimate Mechanical Properties of Polymers," IUPAC Recommendations 1997, *Pure and Applied Chemistry*, **70**, 701-754 (1998).

3.11.2 Other Sources

H.A. Barnes, "Shear-Thickening ("Dilatancy") in Suspensions of Nonaggregating Solid Particles Dispersed in Newtonian Liquids," *Journal of Rheology*, **33**[2], 329-366 (1989).

M. Bohdanecky and J. Kovár, *Viscosity of Polymer Solutions*, Elsevier, Amsterdam, 1982.

E.C. Bingham, "An Investigation of the Laws of Plastic Flow," *U.S. Bureau of Standards Bulletin*, **13**, 309-353 (1916).

F.R. Eirich, Editor, *Rheology - Theory and Applications*, Vol. 1, Academic Press, NY, 1956; Vol. 3, 1960; Vol. 4, 1967.

J.W. Goodwin, "Rheology of Ceramic Materials," *Ceramic Bulletin*, **69**[10], 1694-1698 (1990).

P.C. Hiemenz and R. Rajagopalan, *Principles of Colloid and Surface Chemistry*, 3rd Edition, Chapter 4, pp. 145-192, Marcel-Dekker, 1997.

R.J. Hunter, "Rheology of Colloidal Dispersions," Chapter 18 in *Foundations of Colloid Science*, Vol. 2, Oxford University Press, NY, 1989.

J. Mewis and A.J.B. Spaul, "Rheology of Concentrated Dispersions," *Advances in Colloid and Interface Science*, **6**, 173-200 (1976).

D. Quemada, "Models for Rheological Behavior of Concentrated Disperse Media under Shear", pp. 571-582 in *Advances in Rheology*, Vol. 2: Fluids, Universidad Nacional Autonoma de Mexico, Mexico, 1984.

H.N. Stein, "Rheological Behavior of Suspensions," pp. 3-48 in *Encyclopedia of Fluid Mechanics*, Vol. 5: Slurry Flow Technology, Gulf Publishing Company, Houston, 1986.

J.R. Van Wazer, J.W. Lyons, K.Y. Kim, and R.E. Colwell, *Viscosity and Flow Measurement - A Laboratory Handbook of Rheology*, Interscience Publishers, New York, 1963.

R.W. Whorlow, *Rheological Techniques*, Ellis Horwood Ltd., Chichester, 1980.

A.A. Zaman, *Techniques in Rheological Measurements: Fundamentals and Applications*, Instructional Module, NSF Engineering Research Center for Particle Science and Technology, University of Florida, Gainesville, 1998.

Acknowledgments

American Concrete Institute, International Union of Pure and Applied Chemistry (IUPAC), and The Society of Rheology (Journal of Rheology) have kindly granted permission to use or adapt their published definitions in

◆ Acknowledgements

developing the current document. Their publications are fully cited in the list of primary sources shown above. Extracts from BS 5168:1975 are reproduced with the permission of British Standards Institution under license number PD\1999 0296. Complete copies of the standard can be obtained by post from BSI Customer Services, 389 Chiswick High Road, London W4 4AL.

Ad Hoc Review Committee

Lennart Bergström

YKI (Institute for Surface Chemistry), Stockholm, Sweden

John M. Dealy

Faculty of Engineering, McGill University, Montreal, Canada

Edward J. Garboczi

Leader, Inorganic Materials Group, National Institute of Standards and Technology, Gaithersburg, MD

Robert J. Hunter

School of Chemistry, University of Sydney, Sydney, Australia

Kamal Khayat

Department of Civil Engineering, University of Sherbrooke, Sherbrooke, Canada

François de Larrard

Méthodes et Matériels de Construction et d'Entretien des Routes, Laboratoire Central des Ponts et Chaussées, Bouguenais, France

Makio Naito

Japan Fine Ceramics Center, Nagoya, Japan

Celik Ozyildirim

Virginia Transportation Research Council, Charlottesville, VA

Ponserril Somasundaran

Langmuir Center for Colloids & Interfaces, Department of Chemical Engineering, Columbia University, New York, NY

Abbas A. Zaman

NSF Engineering Research Center for Particle Science & Technology, University of Florida, Gainesville, FL

Index

A

AAN. *See* average agglomeration number

acoustophoresis, 20

adsorbate, 16

adsorbent, 17

adsorption, 16

chemical, 17

monolayer, 17

multilayer, 17

non-specific, 17

physical, 17

specific, 17

adsorption isotherm, 17

aerogel, 6

aerosol, 2

agent

antifoaming, 14

defoaming, 14

dispersing, 14

stabilizing, 14

surface active, 14

agglomerate, 5

agglomeration, 8

aggregate, 5

aggregation, 8

orthokinetic, 9

perikinetic, 9

alcogel, 6

amphoteric, 21

anti-thixotropy. *See* thixotropy, negative

average agglomeration number, 6

B

Bingham equation, 35

BML, 50

Born repulsion, 12

Brownian motion, 14

BTRHEOM, 51

C

capillary methods, 43

Carreau-Yasuda equation, 35

Casson equation, 36

CCC. *See* critical coagulation concentration

CEMAGREF, 51

charge reversal, 19

chemisorption, 17

coacervation, 15

coadsorption, 18

coagulant, 13

coagulate, 5

coagulation, 8

coagulum. *See* coagulate

coaxial. *See* concentric cylinder

coefficient of fluidity, 27

co-ions, 19

colloid, 4

comminution, 9

compact layer, *See* Stern layer

compliance, 29

absolute shear modulus, 42

complex shear, 42

shear, 32

shear loss, 42

shear storage, 42

concentration. *See* relative

concentration terms

concentric cylinder, 46

cone configuration, 46

double-gap configuration, 46

hollow cavity configuration, 46

confined flow methods, 48

consistency, 49

normal, 49

plastic, 50
 wettest stable, 50
consistency factor, 49
consolidation, 49
Couette. See concentric cylinder.
counterions, 19
creep, 38
creep function, 38
critical coagulation
 concentration, 13
Cross equation, 36
CVP. See potential, colloid vibration

D

deagglomeration, 9
deborah number, 38
Debye effect. See potential, ion
 vibration
Debye-Hückel parameter, 22
deflocculant. See agent, dispersing
deflocculation, 9
deformation, 29
desorption, 18
diffuse layer, 16
dilatant, 29
dispersant, 14
dispersing aid. See agent, dispersing
dispersion, 2
DLVO, 11
double layer. See electrical double
 layer
double layer compression, 22
droplet, 5
dynamic equilibrium, 30

E

EDL. See electrical double layer
Einstein coefficient, 30
Einstein's law of viscosity, 30
elastic, 26

electrical double layer, 15
electroacoustics, 20
electroactive. See indifferent
 electrolyte
electrokinetics, 19
electrokinetic sonic amplitude, 21
electro-osmosis, 19
electrophoresis, 20
electroviscous, 26
electroviscous effects
 primary, 26
 secondary, 26
 tertiary, 26
Ellis equation, 36
emulsion, 2
equivalent spherical diameter, 7
ESA. See electrokinetic sonic
 amplitude

F

filling ability, 51
finishing, 49
floc, 6
flocculation, 8
floccule, 7
flow, 30
 dynamic shear, 30
 equilibrium, 30
 laminar, 30
 non-equilibrium, 31
 oscillatory. *See* flow, dynamic
 shear
 steady shear, 33
 steady state. *See* flow, equilibrium
flow cone, 51
flow curve, 30
 Bingham plastic, ideal, 34
 Bingham plastic, non-ideal, 34
 Newtonian, 34
 pseudoplastic with yield, 34
 shear-thickening, 34

shear-thinning with yield, 34
 shear-thinning, 34
flow hysteresis, 39
flow test, 51
fluidity. *See* coefficient of fluidity
forced harmonic oscillation, 39
fractal, 7
free flow methods, 48
Fritsch test. *See* settling method
fusion, 8

G

gel, 6
 gelation, 8
 granule, 5

H

Hamaker constant, 13
hard core repulsion. *See* Born
 repulsion
hard sphere interaction, 13
hard-aggregate, 5
Herschel-Bulkley equation, 36
heteroagglomeration, 9
heterocoagulation, 9
heterodisperse, 3
heteroflocculation, 9
Hooke's law, 30
hydration forces. *See* solvation
 forces
hydrogel, 6
hydrophilic, 21
hydrophobic, 21
hydrosol, 2

I

IBB, 51
IEP. *See* isoelectric point
IHP. *See* plane, inner Helmholtz

impending slough, 49
indifferent electrolyte, 21
interface, 15
interfacial region, 15
interphase, 15
ionic strength, 22
isoelectric point, 18
IVP. *See* potential, ion vibration

K

Krieger-Dougherty equation, 37

L

LCL apparatus, 51
limiting viscosity number. *See*
 viscosity, intrinsic
loss angle. *See* phase lag
lyophilic. *See* hydrophilic
lyophobic. *See* hydrophobic
lyotropic series, 13

M

Meter equation, 37
microsphere, 5
minimum particle size, 7
mobility (concrete), 49
mobility
 dynamic, 20
 electrophoretic, 20
 static, 20
modified slump test, 52
modulus, 31
 absolute shear, 42
 complex shear, 41
 elastic, 30
 shear, 32
 shear loss, 41
 shear storage, 41

modulus of elasticity. *See* modulus, elastic
modulus of rigidity. *See* modulus, shear
monodisperse, 3
MPS. *See* minimum particle size

N

nanosize, 4
Navier-Stokes equations, 31
Newtonian, 31
noninteracting, 13
non-Newtonian, 31
no-slip, 31

O

OHP. *See* plane, outer Helmholtz, 2
Orimet apparatus, 52
Ostwald-de Waele equation. *See* power-law
outer Helmholtz plane, 16

P

particle, 5
 coarse, 4
 fine, 4
 primary, 5
 ultrafine, 4
particulate, 5
Peclet number, 31
penetrating rod, 52
peptization, 9
phase
 continuous, 2
 discontinuous, 2
 dispersed, 2
 liquid, 2
 particulate, 2
 solid, 2

phase lag, 40
physisorption, 17
placeability. *See* workability
plane
 inner Helmholtz, 16
 outer Helmholtz, 16
 shear, 16
plane of shear. *See* plane, shear
plastic, 26
point of zero charge, 18
Poiseuille flow, 31
Poiseuille's Law, 43
polydisperse, 3
polyelectrolyte, 14
potential
 colloid vibration, 20
 electrokinetic, 19
 interaction, 12
 ion-vibration, 20
 shear plane, 18
 streaming, 18
 ultrasonic vibration, 20
 zeta, 18
potential determining ions, 19
potentiometric analysis, 22
powder, 6
Powell-Eyring equation, 38
power-law equation, 38
primary maximum, 12
primary minimum, 12
pseudoplastic. *See* shear-thinning
PZC. *See* point of zero charge

R

rate
 diffusion-limited, 9
 reaction-limited, 10
rate of shear strain. *See* shear rate
rate-controlled (rheometric), 45
relative concentration terms, 4
relaxation time, 39

remolding test. *See* Ve-Be time
 retardation time, 39
 Reynolds number, 31
 rheology, 32
 rheomalaxis, 39
 rheometer, 43
 Tattersall, 52
 rheometric, 32
 rheopexy, 39
 rotational methods, 44
 rotational rheometers, 48

S

Schulze-Hardy rule, 13
 screening, 22
 secondary minimum, 12
 sedimentation, 14
 sedimentation volume, 14
 settling method, 52
 shear, 32
 simple, 33
 shear rate, 32
 shear-thickening, 32
 shear-thinning, 32
 sieve range. *See* particle, coarse
 slip, 2
 slump, 50
 slump cone test, 52
 slurry, 3
 sol, 3
 sol-gel, 9
 solvation forces, 12
 sonication, 10
 sonification, 10
 stability
 colloidal, 10
 kinetic, 10
 stability ratio, 14
 stabilization
 depletion, 11
 electrostatic, 11

 electrosteric, 11
 steric, 11
 Stern layer, 16
 strain
 shear, 32
 strain amplitude, 40
 stress, 33
 normal, 33
 shear, 32
 yield, 33
 stress amplitude, 40
 stress growth, 39
 stress relaxation, 39
 stress-controlled (rheometric), 45
 structural forces, 12
 structure, 33
 subsieve range. *See* particle, fine
 supporting electrolyte, 21
 surface charge density, 18
 surface of shear, 16
 surface potential, *See* potential,
 surface
 surface region, 15
 surfactant, 14
 suspension, 3
 stable, 11
 unstable, 11
 suspension effect, 22
 syneresis, 10

T

Tattersall. *See* rheometer,
 Tattersall
 thermal motion, 14
 thixotropy, 39
 negative, 39
 titrant, 22
 titration, 22
 titrimetric analysis, 22
 triple layer model. *See* electrical
 double layer
 two-point test, 52

U

ultimate working unit, 7
ultrasonication, 10
UVP. *See* **potential, ultrasonic vibration**

V

Ve-Be time, 53
V-funnel cone. *See* **flow cone**
vibration methods, 48
Vicat apparatus, 53
viscoelastic, 26
viscoelectric, 26
viscometer, 43
 Brookfield type. *See* **simple rotational extrusion capillary**, 44
 glass capillary, 43
 simple rotational, 45
 turning tube, 52
viscoplastic, 27
viscosity
 apparent, 27
 coefficient of, 27
 complex, 27
 differential, 27
 dynamic, 28
 infinite shear, 28
 intrinsic, 28
 kinematic, 28
 non-Newtonian, 27
 out-of-phase, 28
 plastic, 28

 reduced, 29
 relative, 29
 specific, 29
 zero shear, 29
viscosity number. *See* **viscosity, reduced**
viscosity ratio. *See* **viscosity, relative**
viscous, 27

W

Weissenberg effect, 33
Weissenberg number, 33
well-dispersed, 3
workability, 50

X

xerogel, 6

Y

yield response, 33
yield stress, 33
 apparent, 29

Z

zero point of charge. *See* **point of zero charge**
zeta potential. *See* **potential, zeta zwitterionic**, 21

