



Top-down Shrug with Collar

■ ■ ■ □ Intermediate

Sizes

S (M, L, XL, XXL) Shown in size S (see Notes)

Finished Measurements

Bust, with fronts meeting in center:
32¼ (36¼, 40¼, 44¼, 47¼)" [82 (92, 102, 112.5, 120) cm]
Length from base of collar to lower edge:
11½ (13, 14½, 16, 17)" [29 (33, 37, 40.5, 43) cm]

Yarn

Nashua Handknits Paradise
(48% Baby Alpaca, 48% Wool, 4% Nylon;
50 g = 87 yards [80 m])
NPA.1897 (rust): 5 (6, 7, 7, 8) skeins

Needles and Other Materials

Circular knitting needle (24" or 32" [60 or 80 cm])
in size US 10 [6 mm]
or size needed to obtain gauge
Circular knitting needle (24" or 32" [60 or 80 cm])
in size US 9 [5.5 mm]
Stitch markers
Stitch holders
One 1" [2.5 cm] button

Gauge

16 sts and 21 rows to 4" [10 cm] in St st using larger needle;
16 sts and 30½ rows to 4" [10 cm] in Garter St using larger
needle. **Take time to save time, check your gauge.**

NOTES

The shrug is worked in one piece from the top of the collar down to the lower edge.

Finished sizes are given with the fronts just meeting in the center.

The shrug can also be worn with a gap at center front as shown in the photographs to accommodate larger sizes.

Measure all lengths straight up along a single column of stitches; do not measure lengths along diagonal raglan increase lines.

SHRUG

Collar: With larger needle, cast 102 sts. Do not join. Work Garter St for 7" [18 cm].

Next row (WS): K2, *k2tog, k2; rep from * – 77 sts.

Upper body:

Row 1 (RS): K11 for left front, place marker (pm), k18 for left sleeve, pm, k19 for back, pm, k18 for right sleeve, pm, k11 for right front; slip markers on following rows as you come to them.

Rows 2 and 4 (WS): K8, purl to last 8 sts, k8.

Row 3 (buttonhole row): Knit to last 5 sts, k2tog, yo, k3.

Row 5: *Knit to 1 st before marker, yo, k1, slip marker, k1, yo; rep from * 3 more times, knit to end – 8 sts increased (1 st for each front, 2 sts for back and each sleeve).

Row 6: Rep Row 2.

Row 7: *Knit to 1 st before marker, yo, k1, slip marker, k1, yo, ssk, knit to 3 sts before next marker, k2tog, yo, k1, slip marker, k1, yo; rep from * once more, knit to end – 4 sts increased (1 st for each front, 2 sts for back, no increases for sleeves).

Row 8: Rep Row 2.

Sizes S (M, L) only: Rep Rows 5-8 for patt 10 (12, 14) more times – 209 (233, 257) sts: 33 (37, 41) sts each front, 63 (71, 79) back sts, 40 (44, 48) sts each sleeve; piece meas 9¼ (10¾, 12¼)" [23.5 (27.5, 31) cm] from last row of collar.

Sizes (XL, XXL) only: *Work Rows 5 and 6 twice, then work Rows 7 and 8 once; rep from (5, 4) more times – (209, 189) sts. Rep Rows 5-8 for patt (7, 10) times – (293, 309) sts: (45, 48) sts each front, (87, 93) back sts, (58, 60) sts each sleeve; piece meas (13¾, 14¾)" [(35, 37.5) cm] from last row of collar.

For all sizes: On the next RS row, k33 (37, 41, 45, 48) for left front, place next 40 (44, 48, 58, 60) sts on holder for left sleeve, k63 (71, 79, 87, 93) back sts, place next 40 (44, 48, 58, 60) sts on holder for right

sleeve, k33 (37, 41, 44, 48) for right front – 129 (145, 161, 177, 189) sts.

Lower body: Keeping 8 sts at each side in Garter St, work even in St st for 5 more rows, beg and ending with a WS row. Change to smaller needle and work in Garter St for 1" [2.5 cm]. Bind off all sts.

Sleeves: Return 40 (44, 48, 58, 60) held sts for one sleeve to smaller needle and rejoin yarn with RS facing. Work in Garter St for ¾" [2 cm]. Bind off all sts. Rep for other sleeve.

FINISHING

Sew short sleeve seams. Weave in ends. Sew button to left front to correspond to buttonhole. Weave in ends.

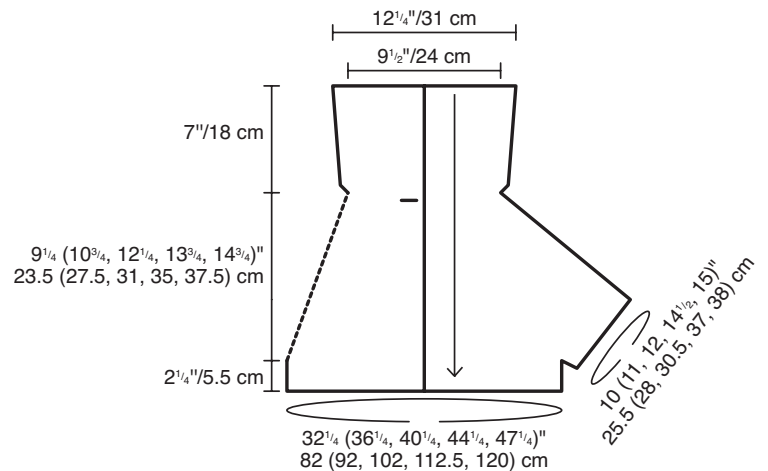

NASHUA
HANDKNITS
NATURAL FIBERS · CREATIVE DESIGNS

from Westminster Fibers, Inc.
www.nashuaknits.com 800 445-9276