

Phase 1 Safety and Immunogenicity Testing of DNA and Recombinant Modified Vaccinia Ankara Vaccines Expressing HIV-1 Virus-like Particles

Paul A. Goepfert,¹ Marnie L. Elizaga,² Alicia Sato,² Li Qin,² Massimo Cardinali,⁴ Christine M. Hay,⁶ John Hural,³ Stephen C. DeRosa,³ Olivier D. DeFawe,³ Georgia D. Tomaras,⁷ David C. Montefiori,⁷ Yongxian Xu,⁸ Lilin Lai,⁹ Spyros A. Kalams,¹⁰ Lindsey R. Baden,¹¹ Sharon E. Frey,¹² William A. Blattner,⁵ Linda S. Wyatt,⁴ Bernard Moss,⁴ Harriet L. Robinson,⁸ and the National Institute of Allergy and Infectious Diseases HIV Vaccine Trials Network

¹Department of Medicine, University of Alabama at Birmingham; ²HIV Vaccine Trials Network Core Operations Center and ³Vaccine and Infectious Disease Institute, Fred Hutchinson Cancer Research Center and University of Washington, Seattle; ⁴National Institute of Allergy and Infectious Diseases, Bethesda; ⁵Institute of Human Virology, University of Maryland at Baltimore; ⁶Department of Medicine, University of Rochester, New York; ⁷Department of Surgery, Duke University Medical Center, Durham, North Carolina; ⁸GeoVax, Smyrna and ⁹Department of Microbiology and Immunology, Emory University, Atlanta, Georgia; ¹⁰Department of Internal Medicine, Vanderbilt University School of Medicine, Nashville, Tennessee; ¹¹Division of Infectious Disease, Brigham and Women's Hospital, Boston, Massachusetts; and ¹²Department of Internal Medicine, Saint Louis University School of Medicine, Missouri

Background. Recombinant DNA and modified vaccinia virus Ankara (rMVA) vaccines represent a promising approach to an HIV/AIDS vaccine. This Phase 1 clinical trial compared the safety and immunogenicity of a rMVA vaccine administered with and without DNA vaccine priming

Methods. GeoVax pGA2/JS7 DNA (D) and MVA/HIV62 (M) vaccines encode noninfectious virus-like particles. Intramuscular needle injections were used to deliver placebo, 2 doses of DNA followed by 2 doses of rMVA (DDMM), one dose of DNA followed by 2 doses of rMVA (DMM), or 3 doses of rMVA (MMM) to HIV-seronegative participants.

Results. Local and systemic symptoms were mild or moderate. Immune response rates for CD4⁺ and CD8⁺ T cells were highest in the DDMM group and lowest in the MMM group (77% vs 43% CD4⁺ and 42% vs 17% CD8⁺). In contrast, response rates for Env binding and neutralizing Ab were highest in the MMM group. The DMM group had intermediate response rates. A 1/10th-dose DDMM regimen induced similar T cell but reduced Ab response rates compared with the full-dose DDMM.

Conclusions. MVA62 was well tolerated and elicited different patterns of T cell and Ab responses when administered alone or in combination with the JS7 DNA vaccine.

The development of an HIV/AIDS vaccine is complicated by numerous factors including the high genetic diversity of the virus, the replication of the virus in immune system cells, and the ability of the virus to become latent. The first 2 candidate HIV vaccines to

enter human efficacy trials (termed AIDS-VAX B/B and AIDS-VAX B/E) consisted of bivalent gp120 subunits of the viral envelope glycoprotein (Env) formulated with alum. These vaccines induced Ab in 100% of vaccinated participants but failed to elicit protective Ab [1]. The next vaccine to complete an efficacy trial was MRKAD5, a trivalent adenovirus 5 (Ad5) vectored vaccine. This vaccine encoded Gag, Pol, and Nef and elicited HIV-specific CD8⁺ and CD4⁺ T cell responses in 75% and 41% of participants, respectively [2], but also failed to protect [3]. The most recent efficacy trial (RV144) tested 4 vaccinations of the vCP1521 canary pox vector, which encoded Gag, protease, and Env, with AIDS-VAX B/E added to the last 2 vaccinations for a protein boost [4].

Received 17 June 2010; accepted 23 November 2010.

Reprints or correspondence: Paul A. Goepfert, MD, University of Alabama at Birmingham, 908 20th Street South, CCB 328, Birmingham, AL 35294 (paulg@uab.edu).

The Journal of Infectious Diseases 2011;203:610–619

© The Author 2011. Published by Oxford University Press on behalf of the Infectious Diseases Society of America. All rights reserved. For Permissions, please e-mail: journals.permissions@oup.com

1537-6613/2011/2035-0001\$15.00

DOI: 10.1093/infdis/jiq105

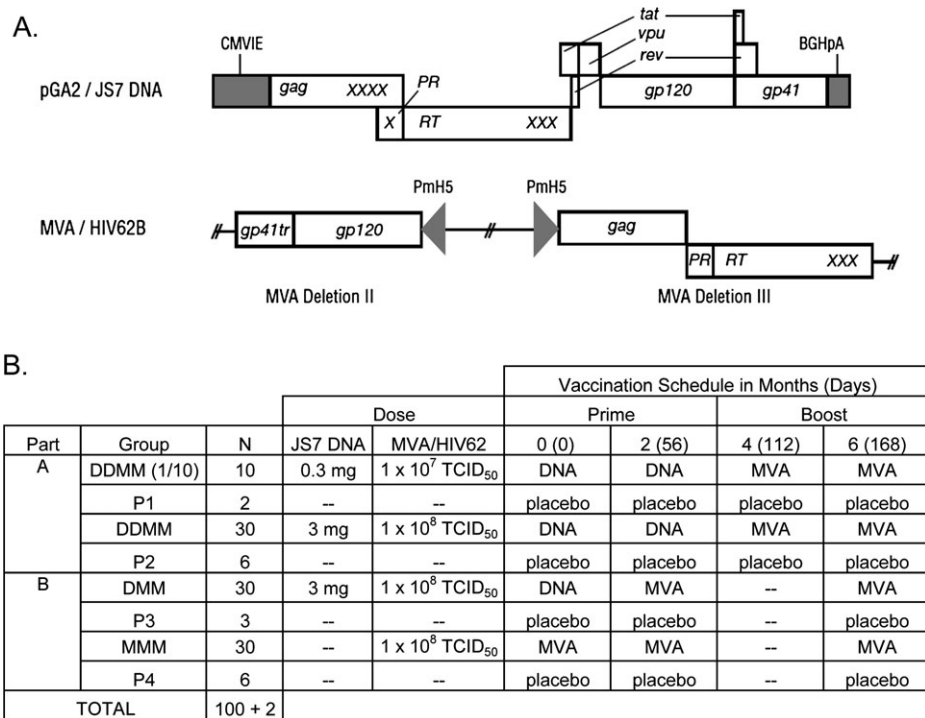

Figure 1. Schematic representations of the HIV-1 vaccines and study design. *A*, Schematics for DNA and recombinant MVA immunogens. *B*, HVTN 065 trial schema. CMVIE, CMV immediate early promoter; *gag*, HIV-1 gene encoding group-specific antigens; PR and RT, protease and reverse transcriptase encoding regions of HIV-1 *pol*; *tat*, *vpu*, and *rev*, HIV-1 regulatory genes; gp120 and gp41, surface and transmembrane subunit-encoding regions of HIV-1 *env*; gp41tr, gp41 with a 115 amino acid C-terminal truncation; BGHPa, bovine growth hormone polyadenylation sequence; x, presence of inactivating point mutations in packaging sequences for viral RNA in Gag and the protease, reverse transcriptase, strand transfer, and RNase H activities of Pol [9]; PmH5, the modified H5 early/late vaccinia promoter; deletions II and III, naturally occurring deletions in MVA.

Although this combination vaccine did not induce measurable CD8⁺ T cells, it did induce antibody and CD4⁺ T cells and provided a 31% protection rate against infection.

The DNA and recombinant modified vaccinia virus Ankara (rMVA) vaccines in this Phase 1 study encode Gag, protease (PR), reverse transcriptase (RT), and the native, membrane-bound trimeric form of Env to produce noninfectious virus-like particles (VLP). In intrarectal challenge studies in macaques, rMVA given with or without DNA prime has induced Ab and T cells, partially controlled high-dose challenges [5, 6], and provided some prevention of infection by repeated moderate-dose challenges [7].

The National Institute of Allergy and Infectious Diseases HIV Vaccine Trials Network (HVTN) conducted a Phase 1 evaluation of the safety and immunogenicity of the pGA2/JS7 DNA and MVA/HIV62 vaccines in healthy, HIV-1 –seronegative adults. MVA62, given alone or with a JS7 DNA priming series, was safe and well tolerated, inducing T cell and antibody responses, which varied depending on the vaccine regimen, dose, and dosing schedule.

SUBJECTS, MATERIALS, AND METHODS

Vaccines

The GeoVax HIV-1 DNA vaccine, pGA2/JS7 DNA (JS7), produces non-infectious virus-like particles (VLPs), and encodes

HIV-1_{HXB-2} Gag, HIV-1_{BH10} PR and RT, and Env, Tat, Rev, and Vpu derived from a recombinant of the HXB-2 and ADA strains of HIV-1 (Figure 1A). The vaccine is rendered noninfectious by gene deletions and inactivating point mutations [8, 9].

Modified vaccinia virus Ankara (MVA) MVA/HIV62 (MVA62) encodes HIV-1 Gag, PR, RT, and Env from the same sequences as JS7 and also produces noninfectious VLP (Figure 1A) [10, 11]. MVA62 contains the RT but not the Gag and PR mutations of JS7. The ADA Env gene is truncated by 115 C-terminal amino acids of gp41, resulting in higher surface expression of Env and the elicitation of higher Ab responses in mice [12].

Study Design

HVTN protocol 065 was a randomized, double-blind, placebo-controlled trial conducted at 6 clinical sites in the United States (Figure 1B). Adults aged 18–49 years who were deemed healthy based on medical history, physical exam, laboratory tests, troponin levels, and electrocardiogram (EKG) were enrolled. The study was designed with 10 participants receiving .3 mg of the JS7 (D) and 10⁷ tissue culture infective doses (TCID₅₀) of MVA62 (1/10th dose [M]) at 8-week intervals in the DDMM schedule. After a safety review of the 1/10th-dose DNA vaccinations, 30 participants were randomized to receive full doses of the vaccines (3 mg and 10⁸ TCID₅₀, respectively) in the DDMM

sequence. Once the full-dose DDMM regimen was demonstrated to be adequately safe and immunogenic, part B of the trial was started. This included the enrollment of 30 participants to receive full-dose vaccines in the DMM or MMM sequences with immunizations administered at 0, 8, and 24 weeks. The placebo product used for all groups was saline, and placebo participants were enrolled at a ratio of placebo recipients to vaccines of 1:5.

Vaccines were delivered as 1 mL into the deltoid region intramuscularly by needle injection. Safety evaluations included physical examinations and standard clinical chemistry and hematological tests, supplemented with tests to expand the ability to identify potential cardiac issues, which included troponin levels and 12-lead EKGs. Local injection site (pain, tenderness, redness, erythema, and induration) and systemic (malaise, headache, fever, chills, myalgias, arthralgias, nausea, vomiting, and fatigue) reactogenicity symptoms were assessed for 3 d following each vaccination or until resolution. Reactions were graded as mild, moderate, or severe according to standard criteria (<http://rcc.tech-res.com/safetyandpharmacovigilance/>).

Immune Response Assays

Peripheral blood mononuclear cells (PBMC) cryopreserved within 8 h of venipuncture were obtained 2 weeks after each vaccination and at 3 and 6 months after the last vaccination [13]. HIV-specific T cell responses were measured using intracellular cytokine staining conducted at HVTN central laboratories [2, 14]. Global potential T cell epitope [15] peptide pools representing HIV Env (3 pools), Gag (2 pools), and Pol (3 pools) were used at the final concentration of 1 μ g for each peptide per milliliter. Cells were first stained with the Violet Live/Dead

Fixable Dead Cell Stain [16] and then fixed, permeabilized, and stained with the following reagents: CD3-ECD, CD4-FITC, CD8-PerCP-Cy5.5, IFN- γ -PE-Cy7, IL-2-PE, TNF- α -Alexa 700, and IL-4-APC. Positive responses were identified using the 1-sided Fisher exact test to support comparison of differences between background measurements and the numbers of CD4⁺ or CD8⁺ T cells producing IFN- γ and/or IL-2 in response to peptide stimulation [14]. The breadth and depth of T cell responses [17] were calculated by the number of peptide pools eliciting a positive reaction per vaccinee (8 maximum).

Assays to measure MVA-specific T cell responses were conducted at the Emory Vaccine Center using similar methods. For the MVA assay, stimulations were conducted by infecting PBMC with Western Reserve vaccinia virus at a multiplicity of infection of 1–2 for 6 h, following which GolgiPlug (Pharmingen) was added, and incubations were continued at 37°C overnight. The antibody reagent used was anti-CD3 Alexa 488, anti-IL-2-PE, anti-IFN- γ APC, anti-CD4 PerCP, or anti-CD8 PerCP. Positive results were defined as twice the background of unstimulated cells and >.01% of the total CD4⁺ or CD8⁺ T cells.

Standard HIV enzyme-linked immunosorbent assay (ELISA) and Western blot testing (Abbott Labs) were performed in participants following the final vaccination. Analyses for Env binding and neutralizing activity were conducted by the HVTN laboratories. An ELISA based on alkaline phosphatase and the AttoPhos fluorescent substrate (Hoffman La Roche) was used to measure total binding Ab to the HIV gp41 immunodominant peptide, SP400 (RVLAVERYLRDQQLGIWGCSEKLICTTAV PWNASWSNKSLSNKI) [18]. Fluorescent readings were measured using an M2 plate reader (Molecular Devices), and mean fluorescent intensity for each pair of replicates, with the

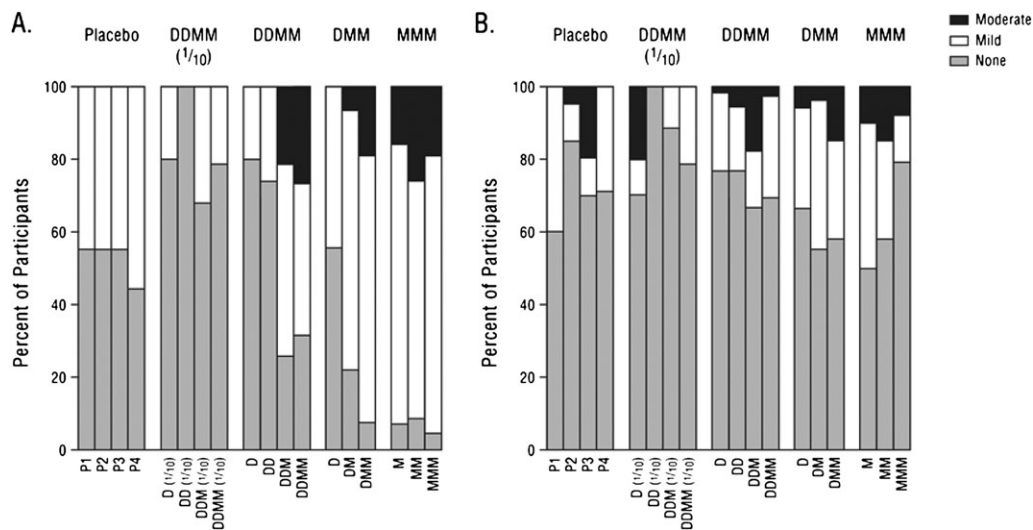

Figure 2. Reactogenicity of study vaccine regimens. The percentage of participants with local pain and/or tenderness (A) or any systemic symptom (B) following each vaccine dose is shown. Reactions were graded as none, mild, moderate, or severe. The vaccine groups are given at the top of the schematics, and the immunization status of groups, at the bottom. D, DNA; M, MVA; P, placebo. The number of Ds and Ms indicates the number of immunizations; for example, DDM means 2 DNA and one MVA immunization. For more details, see Subjects, Materials, and Methods.

background subtracted, was calculated. Standard curves were generated from the plot of fluorescence against the log of serum dilution, and sigmoidal curves were fit using a 4-parameter logistic equation (Softmax Pro). Positive responses for each serum dilution were defined as 3 times the value at baseline.

HIV neutralization was measured as a reduction in luciferase reporter gene expression after a single round of infection in TZM-bl cells [19]. Neutralization titers were defined as the dilution at which relative luminescence units were reduced by 50% compared with virus control wells after subtraction of background. An assay stock of HIV-1 MN was produced in H9 cells, and a stock of molecularly cloned ADA Env-pseudotyped virus was produced by transfection in 293T cells. Samples were considered positive if the neutralization titer that reduced cell killing by 50% was ≥ 25 . Ancillary ELISAs were completed at GeoVax to determine titers of Env Ab specific for the monomeric ADA gp120 produced using a recombinant vaccinia virus. Microtiter plates were coated with sheep Ab to the C-terminus of gp120 (D7324; Aalto BioReagent), ADA gp120 was captured, and serial dilutions of human serum were incubated on duplicate wells with or without ADA gp120. Serial dilutions of HIV-Ig (3957; NIH AIDS Research and Reference Reagent Program) with known levels of gp120-binding Ab were used as the standard on each plate. Bound antibody was detected with IgG-specific antiserum conjugated to peroxidase and TMB peroxidase substrate (KPL). Optical densities were read using a Molecular Devices machine, and the ng of bound antibody was estimated from the HIV-Ig sigmoidal curve generated using 4-parameter logistic software (Softmax Pro). Samples were considered positive if they were at least 3 times background and had a total estimated concentration of ≥ 10 ng of anti-gp120 Ab per milliliter.

Statistical Analysis

For safety, the number and percentage of participants experiencing each type of reactogenicity sign or symptom were tabulated by severity and vaccine regimen using MedDRA preferred terms. Then for a given sign or symptom, each participant's reactogenicity was counted once under the maximum severity for all injection visits or the strongest recorded causal relationship to treatment. For immunogenicity, box plots of local laboratory values by treatment were generated for baseline values and for values measured during the course of the study. Comparisons of immune responses between groups used the Wilcoxon rank-sum test and SAS, S-Plus, or R statistical software.

RESULTS

Participant Accrual, Demographic Data, and Vaccine Safety

The median age of participants was 24 years, and 58% were female. The majority were white (73%) or African American (16%). All 120 participants received their initial vaccine, and 104 (87%) received all prescribed doses. Of those who did not,

all but 1 discontinued further doses for reasons unrelated to the vaccine. Two were discontinued from vaccination due to adverse events. One developed chest tightness and dyspnea 30 min after vaccination, which was probably related to vaccination; another had an adverse event unrelated to vaccination.

The vaccines were safe and well tolerated at both doses and using all schedules without severe reactogenicity (Figure 2). Participants had similar mild or no local side effects after placebo and JS7 DNA administrations (at 1/10th or full dose). The low-dose MVA62 vaccine was also associated with only mild local side effects. However, the full-dose MVA was associated with an increased number of participants experiencing either mild or moderate local reactogenicity (Figure 2A). Most of the local side effects included pain at the injection site. The majority of participants had either no or mild systemic side effects with a few moderate reactions, and there were no differences when compared with placebo recipients (Figure 2B). There were 7 adverse events that were at least probably or definitely attributed to the vaccine, and 6 of these were mild local reactions. One individual experienced a moderate decrease in neutrophils 14 d following the first DNA vaccination, but this resolved and did not recur following subsequent injections. There were no laboratory abnormalities or EKG changes that could be attributable to this vaccine administration.

HIV-1-specific T Cell Responses

HIV-1-specific T cell responses were readily detected in all groups; however, the response rates depended on the vaccine regimen (Figure 3). The DNA prime enhanced both CD4 and CD8 response rates, with 2 DNA primes (either 1/10th or full dose) being more effective than a single full-dose DNA prime. Vaccine-induced CD4⁺ T cells were measured in 88% of individuals vaccinated with the 1/10th-dose and 77% of those vaccinated with the full-dose DDMM regimen. This compared to peak CD4⁺ response rates of 50% for DMM and 43% for MMM regimens (Figure 3A). Peak CD8⁺ T cell responses were 33% in the participants receiving 1/10th-dose and 42% in participants receiving the full-dose DDMM regimens compared to 22% and 17% in participants in the DMM and MMM regimens, respectively (Figure 3B). The magnitudes of responses were overlapping for all groups, with medians between .07 and .17% of total CD4⁺ T cells and between .06 and .65% of total CD8⁺ T cells (Figures 4 and 5A). Male and female participants had similar response rates (data not shown).

The time courses and persistence of T cell responses differed for the full-dose DDMM and MMM regimens (Figures 3 and 4). Both the rates and magnitudes of CD4⁺ T cell responses were maximal and remained maximal after the first MVA inoculation in the DDMM and DMM groups, whereas responses peaked and then fell after the second dose of MVA62 in the MMM group. In contrast, CD8⁺ T cell response rates, but not magnitudes, increased with the last dose of MVA in the DDMM and DMM

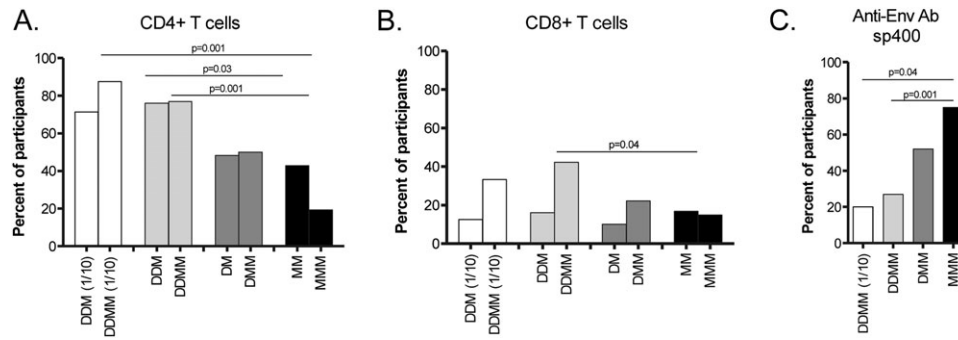

Figure 3. Immune response rates determined in end point assays. Response rates for CD4⁺ T cells (A), CD8⁺ T cells (B), and anti-Env Ab (C). Responses for CD4⁺ and CD8⁺ T cells are for responses to Gag, Env, or Pol measured as IFN- γ – or IL-2–producing cells scored using intracellular cytokine staining (ICS) following stimulation with potential T cell epitope peptide pools. Response rates for anti-Env Ab were measured using an ELISA for the SP400 peptide, a peptide representing the immunodominant region of gp41. Lymphocytes and serum for determining response rates were harvested at 2 weeks following immunizations. Significant differences between groups are indicated where appropriate. All assays were performed in HVTN laboratories on frozen samples. Letters at the bottom of schematics indicate group and the immunization status of groups. See Subjects, Materials, and Methods for more details.

groups, whereas these fell slightly with the last dose of MVA62 in the MMM regimen. At 6 months following the final vaccination, CD4⁺ T cell response rates were 38% for DDMM (49% of their 2-week peak) compared with 8% for MMM (19% of their 2-week peak) ($P = .03$); and CD8⁺ T cell response rates were 38% for DDMM (90% of their peak) compared with 4% for MMM (24% of their peak) (Figure 4).

For the DDMM and MMM regimens, the functionality of T cell responses, as measured by coproduction of IFN- γ , IL-2, and TNF- α , were similar except for different patterns for single-cytokine-producing cells (Figures 4C and 4D). Among the single-cytokine-producing CD4⁺ cells, IL-2 predominated in the DDMM group and TNF- α , in the MMM group. Among single-cytokine-producing CD8⁺ T cells, IFN- γ production was most frequent in the DDMM group, whereas no single cytokine dominated in the MMM group. For both regimens, approximately one-third of the responding cells produced 3, 2, or 1 cytokine (Figures 4E and 4F).

The breadth and depth [17] of T cell responses against 2 Gag, 3 Env, and 3 Pol peptide pools revealed responses primarily directed to Gag and Env (Figure 5A). The DNA prime increased the breadth and depth of the T cell response, and priming with 2 doses of DNA (low or full dose) provided a broader response than priming with a single dose of DNA (Figure 5B). Following the final immunization, CD4⁺ and CD8⁺ T cells in DDMM recipients recognized medians of 4 and 2 peptide pools, respectively, compared to medians of 1 for CD4⁺ and CD8⁺ responses in MMM vaccine recipients. CD4⁺ T cell responses were evenly distributed between Gag and Env for both DDMM groups but showed a bias toward Gag in the DMM group and a strong bias toward Gag in the MMM group. The kinetics of T cell responses differed for Gag and Env: following the final MVA dose, CD8⁺ T cell response rates for Gag increased 9-fold in the DDMM and 4-fold in the MMM group; whereas CD8⁺

responses for Env increased 2-fold for DDMM recipients and decreased by 3-fold for MMM recipients. The DNA prime biased the response toward CD4⁺ T cells. This bias was strongest after the first MVA boost, when it ranged from a 7-fold to a 14-fold excess of CD4⁺ responses over CD8⁺ responses in the DNA-primed groups compared to a 2.4-fold excess of CD4⁺ over CD8⁺ responses in the MMM group.

HIV-1-specific Antibody Responses

In contrast to T cell responses, HIV-1 –specific antibodies were induced more frequently and at higher levels by the full-dose than the 1/10th-dose DDMM regimen, and the highest frequencies and titers of Ab responses were induced by the MMM regimen (Figures 3C and 6). After the final vaccine administration, nearly all MMM recipients (96.6%) tested positive by the Abbott HIV-1/HIV-2 ELISA, whereas only 73% of the DDMM recipients had seroconverted by this test ($P = .03$). A trend toward an increased number of positive Western blot assays was also seen in the MMM (21.4%) versus the full-dose DDMM (4.3%) recipients.

Env-specific antibodies, as measured by binding to an immunodominant Ab for a gp120 monomer of the ADA vaccine Env (SP400 gp41 peptide), and neutralizing activity for HIV-1_{MN}, were all highest in the MMM group (Figure 6). Participants receiving the full-dose DDMM regimen had the lowest Ab responses, and the DMM group had intermediate antibody responses. The higher titers of Ab present in the MMM group were associated with this group receiving 3 doses of MVA. Following 2 doses of MVA, Ab responses were overall similar in the DDMM and DMM groups compared with those in the MMM group after 2 doses of MVA (Figure 6). Samples able to neutralize HIV-1_{MN} were further tested for their ability to neutralize select tier 1 isolates (Figure 6D). Recipients of the DMM and MMM regimens were able to neutralize tier 1 isolates, with

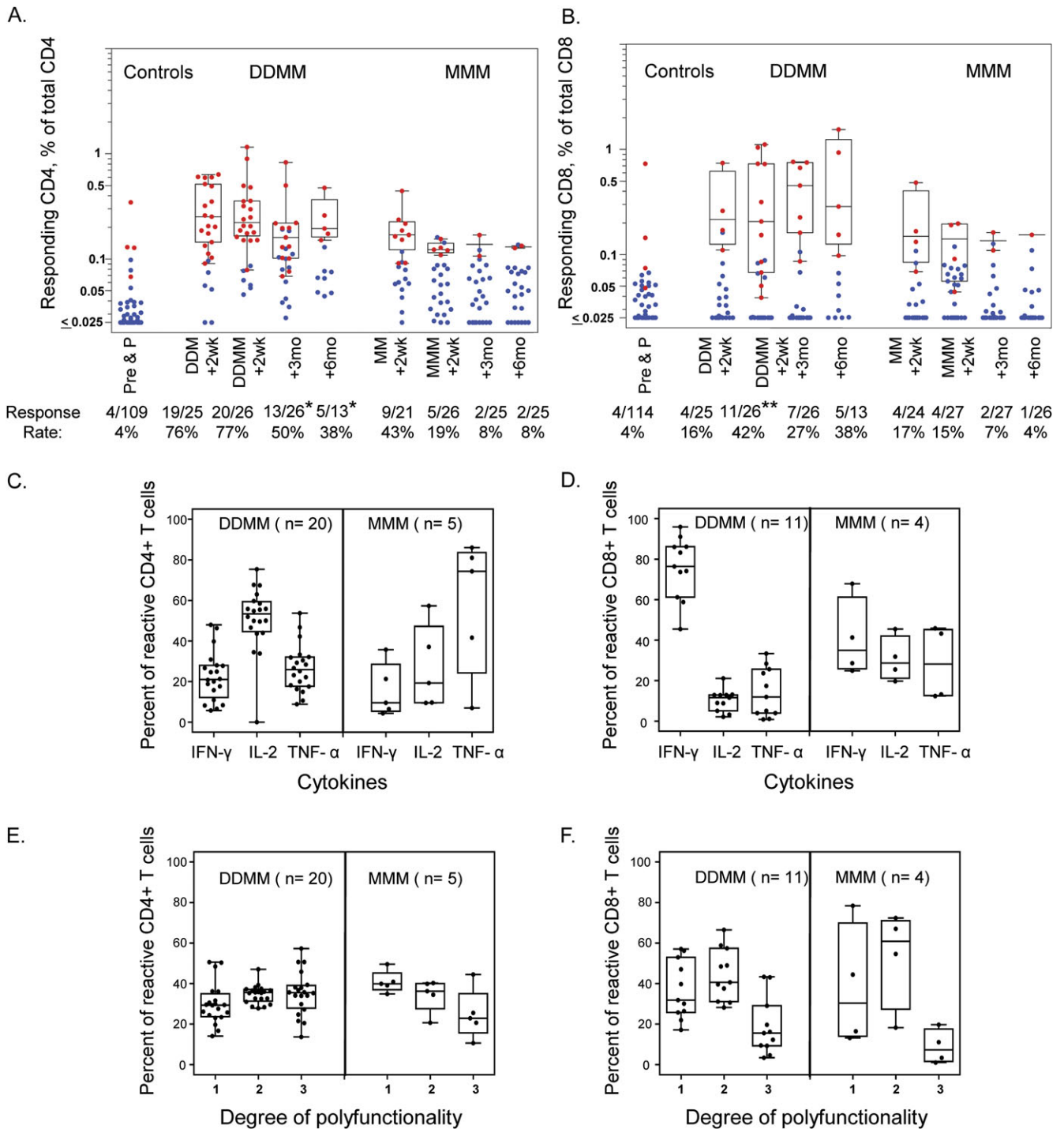

Figure 4. Magnitude and persistence of vaccine-induced T cell responses. The magnitudes of CD4⁺ (A) and CD8⁺ (B) T cell responses following full-dose DDMM and MMM vaccine regimens are shown. Data represent responses directed against Gag and Env as measured by IFN- γ and/or IL-2 production of CD4⁺ and CD8⁺ T cells in an intracellular cytokine staining (ICS) assay (for more details, see Subjects, Materials, and Methods). Box plots represent the median and 25th and 75th percentiles for positive data (indicated by red points); blue points indicate negative data. Response rates are shown below the schematics as the number of participants who tested positive out of the total number of participants tested, with the percentage of responders given immediately below. Pre&P, prebled at baseline and placebo; +2wk, samples harvested at 2 weeks after an injection; +3mo and +6mo, samples harvested at 3 or 6 months after the last injection. Letters at the bottom of the schematics indicate the group and the immunization status of the groups. D, DNA; M, MVA; P, placebo. The number of Ds and Ms indicates the number of immunizations; for example, DDM means 2 DNA and one MVA immunization. * $P < .05$ for CD4⁺ T cell response frequency when compared with the +2-week time point following the final vaccination in the DDMM regimen; ** $P < .05$ for CD8⁺ T cell response frequency when compared with that seen after the first MVA boost in the DDMM regimen or DMM. C–F, Polyfunctionality of the positive responses for IFN- γ , IL-2, and TNF- α production measured using multicolor flow cytometry and Boolean analyses.

A.

T Cell	Group	Vaccination	% Responders			Median Magnitude		Total # of recognized pools
			Gag	Env	Pol	Gag	Env	
CD4	DDMM(1/10)	DDM	71	43	0	0.07	0.16	58
		DDMM	50	50	0	0.08	0.11	36
	DDMM	DDM	68	60	12	0.15	0.11	72
		DDMM	77	62	4	0.12	0.10	73
	DMM	DM	41	21	0	0.14	0.15	29
		DMM	46	17	0	0.17	0.17	25
	MMM	MM	38	14	0	0.10	0.07	22
		MMM	19	0	0	0.12	NA	7
CD8	DDMM(1/10)	DDM	0	13	0	NA	0.10	4
		DDMM	22	22	0	0.06	0.32	17
	DDMM	DDM	4	12	4	0.65	0.15	10
		DDMM	35	23	0	0.15	0.42	22
	DMM	DM	3	7	0	0.08	0.06	3
		DMM	19	4	0	0.12	0.07	7
	MMM	MM	4	13	4	0.20	0.14	9
		MMM	15	4	0	0.07	0.10	6

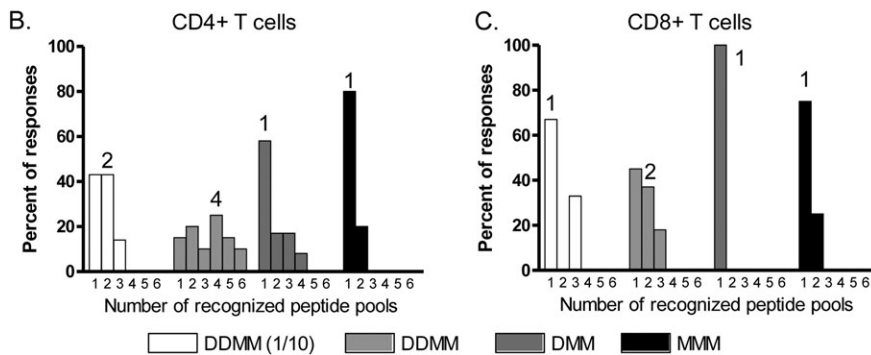

Figure 5. Breadth/depth and magnitude of T cell responses to Gag and Env. *A*, Percent responders, median magnitudes, and total number of recognized peptide pools for the 4 vaccine regimens. The total number of recognized pools represents the sum of all of the peptide pools recognized in assays successfully completed for a group normalized to the maximum number of individuals tested for CD4⁺ and CD8⁺ T cell responses in that group. Note that this normalization was largest for the low-dose DDMM group that had only 10 participants compared to the 30 participants in the other groups. *B–C*, Percent of responders with CD4⁺ or CD8⁺ T cells, respectively, recognizing different numbers of peptide pools. The numbers in the graph are the median number of peptide pools recognized by responders to a particular regimen. D, DNA; M, MVA; P, placebo. The number of Ds and Ms indicates the number of immunizations; for example, DDM means 2 DNA and one MVA immunization. Note that the numbers represent the breadth and/or depth of induced T cells as defined elsewhere [17]. Potential T cell epitope pools are grouped depending on the frequency of HIV-1 epitope variants, so variants of the same epitope may be in different peptide pools [15].

a trend toward the greatest breadth in the MMM group. No neutralization was observed against tier 2 isolates including HIV-1_{ADA}.

Vector-induced Immune Responses

The CD4⁺ and CD8⁺ T cell responses specific to the MVA vector were assessed following the MVA62 boosts. Subsequent to the first MVA boost, both the response rates and magnitudes of vaccinia-specific CD4⁺ and CD8⁺ T cells were significantly

lower in those receiving the DNA prime compared with those receiving only MVA62 ($P < .001$) (Figure 7).

DISCUSSION

The MVA62 immunizations, both with and without JS7 DNA priming, were well tolerated, with only mild to moderate reactivity following the MVA vaccinations. Consistent with pre-clinical testing in rhesus macaques [5, 6, 20, 21], all of the tested

Shown are the percentages of CD4⁺ (*C*) and CD8⁺ (*D*) T cells producing single cytokines and the degree of polyfunctionality for the CD4⁺ (*E*) and CD8⁺ (*F*) responses. 1, the percent of responding cells producing a single cytokine; 2, the percent producing 2 cytokines; 3, the percent producing 3 cytokines. The numbers (*n*) in panels C–F represent the number of participants in each group with positive CD4⁺ or CD8⁺ T cell responses to any gene as measured by IFN- γ and/or IL-2 production.

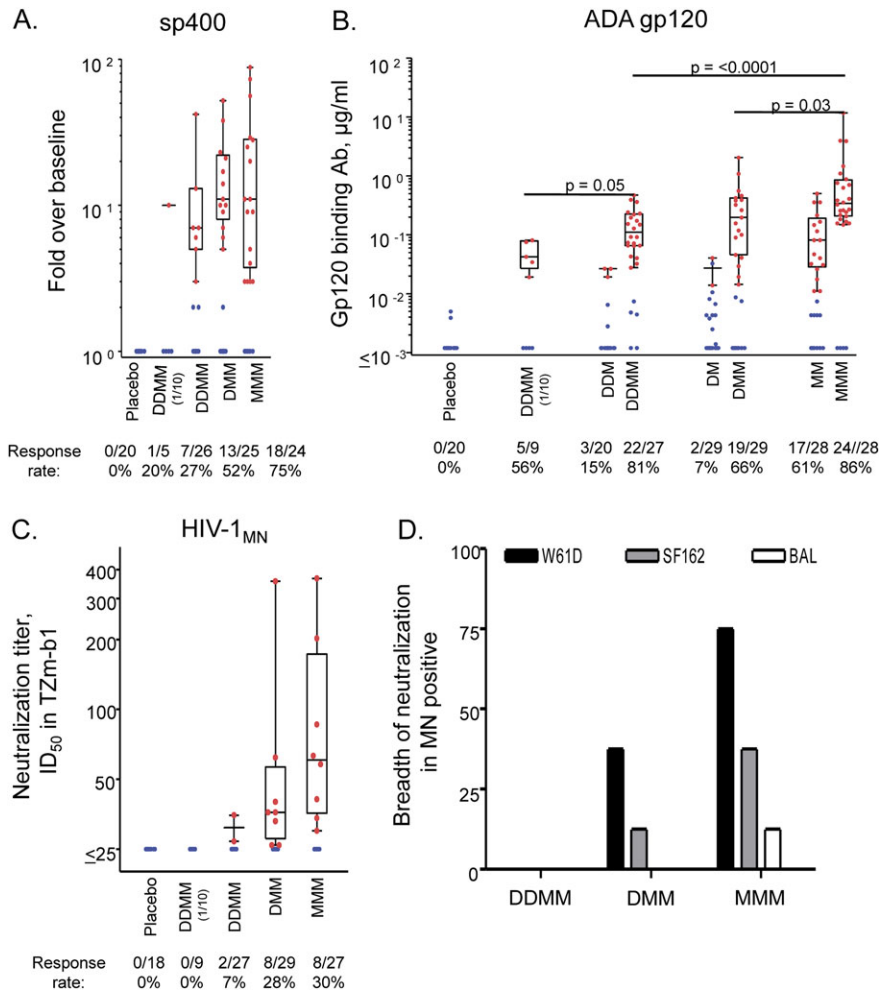

Figure 6. Magnitudes and response rates of Env binding and neutralizing antibodies. *A*, Binding Ab for SP400, a peptide representing the immunodominant region of gp41. *B*, Binding Ab for ADA gp120. *C*, Neutralizing Ab for HIV-1_{MN}. Designations below schematics indicate groups and response rates (see legend to Figure 4 for details). The box plots show median and 25th and 75th percentiles for positive data (indicated by red points); blue points indicate negative data. Data for determining *P* values include only positive data. *D*, Percent of positive MN neutralization responses also neutralizing other tier 1 isolates. Seventeen of the samples demonstrating neutralization against HIV-1_{MN} were evaluated further. The tier 1 isolates are shown including HIV-1_{SF162}, HIV-1_{W61D} (T cell laboratory-adapted strain), and HIV-1_{BAL}.

regimens induced both T cell and Ab responses. However, the DDMM regimen induced the highest frequency and most persistent CD4⁺ and CD8⁺ T cell responses. The DNA prime also increased the breadth and depth of the T cell responses and biased these responses toward CD4⁺ T cells. On the other hand, the MMM regimen induced the highest frequency and magnitude of antibody responses. The single DNA prime (DMM) induced intermediate T cell and Ab responses. The 1/10th-dose DDMM regimen decreased the height of Ab responses but had limited effect on T cell responses.

Priming with 2 DNA vaccinations was important for optimal T cell response rates and breadths following the MVA boost. DNA priming was also important for enhanced persistence of T cell responses. This priming occurred despite detectable T cell responses not being elicited by the JS7 DNA primes (data not shown) or a similar DNA vaccine studied in a previous clinical

trial [22]. Thus T cell responses, below the level of detection by ex vivo analysis, were able to focus T cells to HIV antigens expressed by MVA62. Moreover, the absence of detectable DNA-elicited responses did not preclude the DNA prime curtailing anti-MVA T cell responses. Presumably this effect was due to the DNA prime establishing memory T cells recognizing HIV antigens that competed for antigen presentation during the boost with naive T cells recognizing MVA or HIV antigens.

For all regimens, the number of MVA boosts was important for increasing both anti-Gag CD8⁺ T cell and anti-Env Ab responses. The last MVA boost increased anti-Gag CD8⁺ response rates from 4% to 35% and from 4% to 15% for the DDMM and MMM regimens, respectively. The higher Ab responses in the MMM regimen correlated with this regimen receiving 3 MVA inoculations as opposed to the 2 MVA boosts for the DNA-primed regimens. Prior studies suggest that an additional MVA

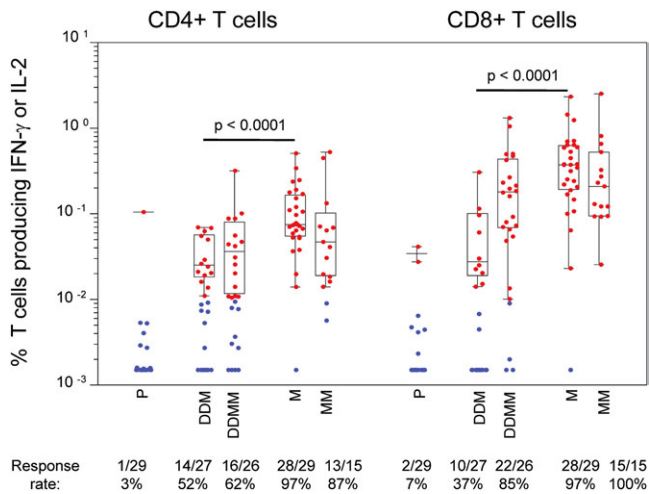

Figure 7. Vector-specific T cells. The percentage of MVA-specific CD4⁺ or CD8⁺ T cells producing IFN- γ by ICS assay is shown for samples analyzed at 1 week following the first or second MVA boost for the DDM and MM vaccine regimens. The percentage of participants with vector-specific T cell responses (response rate) is given below the schematic.

boost would further increase responses but that this increase would be limited by vaccine-induced immunity curtailing further boosting [20, 23]. Ab responses were also affected by the number of DNA primes, with a single full-dose DNA prime tending to give higher Ab responses after the MVA boost than 2 full-dose DNA primes. This could reflect the DNA prime eliciting immune responses that curtailed Ab as well as MVA-specific CD8⁺ responses. Additionally, the JS7 DNA prime may have elicited a Th1-like response so that it more optimally primed memory T than memory B cells [24].

Prior Phase 1 testing of recombinant poxvirus vectors has revealed DNA consistently priming higher T cell responses. However, both the poxvirus vector and the vaccine insert have influenced results. Recombinant DNA and MVA vaccines that express strings of CD8 epitopes have elicited much lower T cell responses than observed in this trial and in another trial expressing whole proteins [25, 26]. Boosting a DNA-primed response with a New York vaccinia virus vector (NYVAC) elicited responses that were biased toward Env and even more biased toward CD4⁺ T cells than elicited by JS7 DNA priming and MVA62 boosting [27]. Also, without DNA priming, the NYVAC vector, in contrast to MVA62, was more effective in women than men [28]. The canary pox vector used in the first HIV/AIDS vaccine trial to generate some protection [4] has been tested with several different inserts and vector variations and has been generally less effective at eliciting CD4⁺ and CD8⁺ T cell responses than MVA62 [29–33].

Despite the MVA62 vaccine eliciting different patterns of immune responses in the presence and absence of a JS7 DNA

prime, it is difficult to predict whether a JS7 prime would add to the protective efficacy of the MVA62 vaccine. The higher Ab elicited by the MVA62 alone could be critical to protection. In preclinical studies, the avidity of the anti-Env Ab response for the native trimeric form of Env has been a strong correlate with control of peak viremia following high-dose intrarectal challenges [20, 21]. However, the higher T cells elicited by MVA62 in the presence of a JS7 DNA prime could also be important. For example, data from preclinical studies using nonreplicating adenovirus- and cytomegalovirus-based vectors have shown the magnitude of T cell responses correlating with protection [34, 35]. Given the fact that a correlate for protection is not known for HIV/AIDS vaccines, both regimens may merit further clinical development.

Acknowledgments

This trial was conducted by the HIV Vaccine Trials Network and was sponsored by the National Institute of Allergy and Infectious Diseases. We gratefully acknowledge the participation and support of many colleagues and staff at each site and are particularly grateful for the participation of the 120 study participants. We also thank Molly Swenson, Carter Bentley, and Huguette Redinger for their tireless support in the daily operations of the protocol.

References

1. Flynn NM, Forthal DN, Harro CD, Judson FN, Mayer KH, Para MF. Placebo-controlled Phase 3 trial of a recombinant glycoprotein 120 vaccine to prevent HIV-1 infection. *J Infect Dis* **2005**; 191:654–65.
2. McElrath MJ, De Rosa SC, Moodie Z, et al. HIV-1 vaccine-induced immunity in the test-of-concept Step Study: a case-cohort analysis. *Lancet* **2008**; 372:1894–905.
3. Buchbinder SP, Mehrotra DV, Duerr A, et al. Efficacy assessment of a cell-mediated immunity HIV-1 vaccine (the Step Study): a double-blind, randomised, placebo-controlled, test-of-concept trial. *Lancet* **2008**; 372:1881–93.
4. Rerks-Ngarm S, Pitisuttithum P, Nitayaphan S, et al. Vaccination with ALVAC and AIDSVAX to prevent HIV-1 infection in Thailand. *N Engl J Med* **2009**; 361:2209–20.
5. Amara RR, Villingier F, Altman JD, et al. Control of a mucosal challenge and prevention of AIDS by a multiprotein DNA/MVA vaccine. *Science* **2001**; 292:69–74.
6. Amara RR, Villingier F, Staprans SI, et al. Different patterns of immune responses but similar control of a simian–human immunodeficiency virus 89.6P mucosal challenge by modified vaccinia virus Ankara (MVA) and DNA/MVA vaccines. *J Virol* **2002**; 76:7625–31.
7. Ellenberger D, Otten RA, Li B, et al. HIV-1 DNA/MVA vaccination reduces the per exposure probability of infection during repeated mucosal SHIV challenges. *Virology* **2006**; 352:216–25.
8. Smith JM, Amara RR, Campbell D, et al. DNA/MVA vaccine for HIV type 1: effects of codon-optimization and the expression of aggregates or virus-like particles on the immunogenicity of the DNA prime. *AIDS Res Hum Retroviruses* **2004**; 20:1335–47.
9. Smith JM, Amara RR, McClure HM, et al. Multiprotein HIV type 1 clade B DNA/MVA vaccine: construction, safety, and immunogenicity in macaques. *AIDS Res Hum Retroviruses* **2004**; 20:654–65.
10. Wyatt LS, Earl PL, Liu JY, et al. Multiprotein HIV type 1 clade B DNA and MVA vaccines: construction, expression, and immunogenicity in rodents of the MVA component. *AIDS Res Hum Retroviruses* **2004**; 20:645–53.

11. Wyatt LS, Earl PL, Vogt J, et al. Correlation of immunogenicities and in vitro expression levels of recombinant modified vaccinia virus Ankara HIV vaccines. *Vaccine* **2008**; 26:486–93.
12. Wyatt LS, Belyakov IM, Earl PL, Berzofsky JA, Moss B. Enhanced cell surface expression, immunogenicity and genetic stability resulting from a spontaneous truncation of HIV Env expressed by a recombinant MVA. *Virology* **2008**; 372:260–72.
13. Bull M, Lee D, Stucky J, et al. Defining blood processing parameters for optimal detection of cryopreserved antigen-specific responses for HIV vaccine trials. *J Immunol Methods* **2007**; 322:57–69.
14. Horton H, Thomas EP, Stucky JA, et al. Optimization and validation of an 8-color intracellular cytokine staining (ICS) assay to quantify antigen-specific T cells induced by vaccination. *J Immunol Methods* **2007**; 323:39–54.
15. Li F, Malhotra U, Gilbert PB, et al. Peptide selection for human immunodeficiency virus type 1 CTL-based vaccine evaluation. *Vaccine* **2006**; 24:6893–904.
16. Peretto SP, Chattopadhyay PK, Lamoreaux L, et al. Amine reactive dyes: an effective tool to discriminate live and dead cells in polychromatic flow cytometry. *J Immunol Methods* **2006**; 313:199–208.
17. Barouch DH, O'Brien KL, Simmons NL, et al. Mosaic HIV-1 vaccines expand the breadth and depth of cellular immune responses in rhesus monkeys. *Nat Med* **2010**; 16:319–23.
18. Tomaras GD, Yates NL, Liu P, et al. Initial B-cell responses to transmitted human immunodeficiency virus type 1: virion-binding immunoglobulin M (IgM) and IgG antibodies followed by plasma anti-gp41 antibodies with ineffective control of initial viremia. *J Virol* **2008**; 82:12449–63.
19. Li M, Gao F, Mascola JR, et al. Human immunodeficiency virus type 1 Env clones from acute and early subtype B infections for standardized assessments of vaccine-elicited neutralizing antibodies. *J Virol* **2005**; 79:10108–25.
20. Lai L, Vodros D, Kozlowski PA, et al. GM-CSF DNA: an adjuvant for higher avidity IgG, rectal IgA, and increased protection against the acute phase of a SHIV-89.6P challenge by a DNA/MVA immunodeficiency virus vaccine. *Virology* **2007**; 369:153–67.
21. Zhao J, Lai L, Amara RR, et al. Preclinical studies of human immunodeficiency virus/AIDS vaccines: inverse correlation between avidity of anti-Env antibodies and peak postchallenge viremia. *J Virol* **2009**; 83:4102–11.
22. Mulligan MJ, Russell ND, Celum C, et al. Excellent safety and tolerability of the human immunodeficiency virus type 1 pGA2/JS2 plasmid DNA priming vector vaccine in HIV type 1 uninfected adults. *AIDS Res Hum Retroviruses* **2006**; 22:678–83.
23. Ourmanov I, Brown CR, Moss B, et al. Comparative efficacy of recombinant modified vaccinia virus Ankara expressing simian immunodeficiency virus (SIV) Gag-Pol and/or Env in macaques challenged with pathogenic SIV. *J Virol* **2000**; 74:2740–51.
24. Mosmann TR, Cherwinski H, Bond MW, Giedlin MA, Coffman RL. Two types of murine helper T cell clone. I. Definition according to profiles of lymphokine activities and secreted proteins. *J Immunol* **1986**; 136:2348–57.
25. Hanke T, Goonetilleke N, McMichael AJ, Dorrell L. Clinical experience with plasmid DNA- and modified vaccinia virus Ankara-vectored human immunodeficiency virus type 1 clade A vaccine focusing on T-cell induction. *J Gen Virol* **2007**; 88:1–12.
26. Sandstrom E, Nilsson C, Hejdeman B, et al. Broad immunogenicity of a multigene, multiclade HIV-1 DNA vaccine boosted with heterologous HIV-1 recombinant modified vaccinia virus Ankara. *J Infect Dis* **2008**; 198:1482–90.
27. Harari A, Bart PA, Stohr W, et al. An HIV-1 clade C DNA prime, NYVAC boost vaccine regimen induces reliable, polyfunctional, and long-lasting T cell responses. *J Exp Med* **2008**; 205:63–77.
28. McCormack S, Stohr W, Barber T, et al. EV02: a Phase I trial to compare the safety and immunogenicity of HIV DNA-C prime-NYVAC-C boost to NYVAC-C alone. *Vaccine* **2008**; 26:3162–74.
29. Goepfert PA, Horton H, McElrath MJ, et al. High-dose recombinant canarypox vaccine expressing HIV-1 protein, in seronegative human subjects. *J Infect Dis* **2005**; 192:1249–59.
30. Hel Z, Nacsa J, Tsai WP, et al. Equivalent immunogenicity of the highly attenuated poxvirus-based ALVAC-SIV and NYVAC-SIV vaccine candidates in SIVmac251-infected macaques. *Virology* **2002**; 304:125–34.
31. Pal R, Venzon D, Letvin NL, et al. ALVAC-SIV-Gag-Pol-Env-based vaccination and macaque major histocompatibility complex class I (A*01) delay simian immunodeficiency virus SIVmac-induced immunodeficiency. *J Virol* **2002**; 76:292–302.
32. Pal R, Venzon D, Santra S, et al. Systemic immunization with an ALVAC-HIV-1/protein boost vaccine strategy protects rhesus macaques from CD4⁺ T-cell loss and reduces both systemic and mucosal simian-human immunodeficiency virus SHIVKU2 RNA levels. *J Virol* **2006**; 80:3732–42.
33. Russell ND, Graham BS, Keefer MC, et al. Phase 2 study of an HIV-1 canarypox vaccine (vCP1452) alone and in combination with rgp120: negative results fail to trigger a Phase 3 correlates trial. *J Acquir Immune Defic Syndr* **2007**; 44:203–12.
34. Hansen SG, Vieville C, Whizin N, et al. Effector memory T cell responses are associated with protection of rhesus monkeys from mucosal simian immunodeficiency virus challenge. *Nat Med* **2009**; 15:293–9.
35. Liu J, O'Brien KL, Lynch DM, et al. Immune control of an SIV challenge by a T-cell-based vaccine in rhesus monkeys. *Nature* **2009**; 457:87–91.