

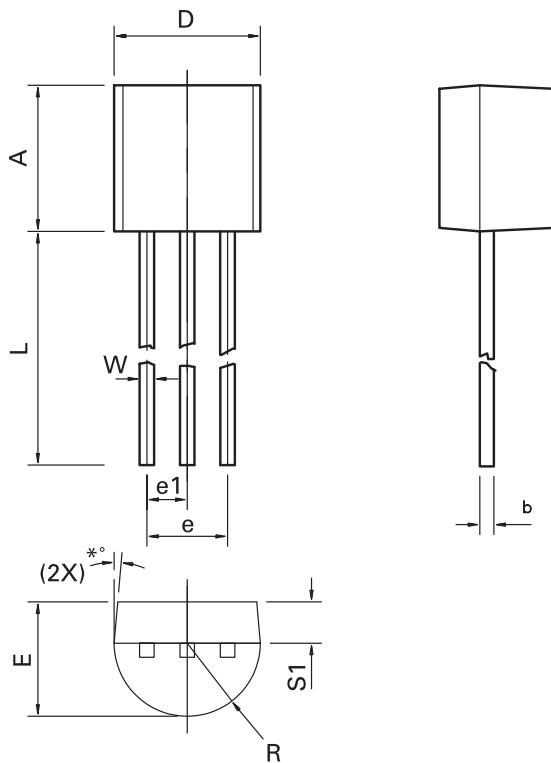

Package information - TO92

Through hole, 3 pin package

Package outline



Dim.	Millimeters		Inches	
	Min.	Max.	Min.	Max.
A	4.32	4.95	0.170	0.195
b	0.36	0.51	0.014	0.020
E	3.30	3.94	0.130	0.155
e	2.41	2.67	0.095	0.105
e1	1.14	1.40	0.045	0.055
L	12.70	15.49	0.500	0.610
R	2.16	2.41	0.085	0.095
S1	1.14	1.52	0.045	0.060
W	0.41	0.56	0.016	0.022
D	4.45	4.95	0.175	0.195
*°	4°	6°	4°	6°

Note: Controlling dimensions are in millimeters. Approximate dimensions are provided in inches

Nominal weight

Nominal weight per device 204mg.

Package information - T092

Tape and reel information

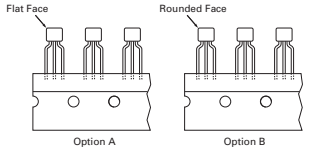
 <p>Flat Face</p> <p>Rounded Face</p> <p>Option A</p> <p>Option B</p>	<p>Part no. suffixed STOB = 1,500 devices on reel</p>
<p>Part no. suffixed STZ = 1,500 devices per folded box</p>	

This publication is issued to provide outline information only which (unless agreed by the company in writing) may not be used, applied or reproduced for any purpose or form part of any order or contract or be regarded as a representation relating to the products or services concerned. The company reserves the right to alter without notice the specification, design, price or conditions of supply of any product or service.