

Multi-period hydrogen management

Ahmad Muhammad Imran., Jobson Megan , Zhang Nan

Centre for Process Integration

School of Chemical Engineering and Analytical Science, The University of Manchester,
PO Box 88, Sackville Street, Manchester, M60 1QD, UK.

Refinery hydrogen network management is a problem of increasing importance as the hydrogen consumption of refineries is rising sharply with additional capacities of hydrocracking and hydrotreating units in order to comply with clean fuel specifications enforced due to environmental concerns. Hydrogen management is the research area dealing with the development of methodologies and approaches for the design and optimisation of refinery hydrogen networks. Hydrogen management technology currently does not account for varying operating conditions of hydrogen consuming processes and assumes constant operating conditions. A novel multi-period approach is developed for design of flexible hydrogen networks that can remain optimally operable under multiple periods of operation. The proposed multi-period hydrogen management can account for pressure constraints, existing equipment, and optimal placement of new equipment such as compressors and purification units.

1. Introduction

Petroleum refineries consist of many processes with complex reactions involving hydrogen consumption or production. Hydrogen management aims to achieve the optimal allocation of hydrogen resources in order to satisfy the demands of refinery processes. Hydrogen management has become a research area with a lot of interest from refiners as the clean fuel specifications are forcing refineries to increase hydroprocessing capacities and the severity of operating conditions. Hydrogen production plants can represent over one-third of the cost of conversion processes for upgrading heavy hydrocarbon feedstocks (Peramanu et al. 1999) therefore hydrogen management is of paramount importance to ensure optimum refinery economic performance.

1.1 Hydrogen network and its components

A hydrogen network can be described as a system of refinery processes that interact with each other through distribution of hydrogen. Refinery processes can be classified as hydrogen producers and hydrogen consumers based on their contribution to the hydrogen network. Hydrogen producers are the units that supply hydrogen to the hydrogen distribution system such as the hydrogen plant and catalytic reforming unit while hydrogen consumers are the conversion processes such as hydrocracking process,

hydrotreating processes, lubricant plants, isomerisation process and hydro de-alkylation unit etc.

2. Review of previous research on hydrogen management

The first systematic approach for the assessment of hydrogen resources of a hydrogen network was proposed by Tower et al. (1996) based on cost and value composite curves. Alves (1999) developed the hydrogen pinch analysis approach based on the analogy to pinch analysis for heat exchanger networks. The hydrogen pinch analysis approach is a tool for the estimation of minimum hydrogen utility requirement of a hydrogen network before the system design. Alves (1999) developed a framework of sinks and sources for hydrogen pinch analysis. A sink is a stream that consumes hydrogen from the hydrogen distribution system while a source is defined as a stream supplying hydrogen to the system. The hydrogen producers and hydrogen consuming processes are represented in the framework of sinks and sources.

Liu (2002) developed a superstructure based optimisation approach for the design of hydrogen networks. This automated design approach also provides a strategy for selection of purification processes and their integration with hydrogen networks.

2.1 Limitations of previous research on hydrogen management

The previous design approaches assume constant operating conditions for all refinery processes constituting a hydrogen network. Because of this assumption these hydrogen management techniques can only help reduce the hydrogen utility but do not provide a framework for analysing the optimal utilisation of the possible saving of hydrogen surplus. Sun (2004) discussed the utilisation of hydrogen, freed up using the network design methods, to improve the performance of a hydrogen consuming process. However, the impact of the changing process conditions on the performance of the hydrogen network is not addressed in his integration analysis.

3. Multi-period hydrogen management

The hydrogen network design approaches discussed so far can not be applied for optimal utilisation of hydrogen to improve the economic performance of refinery processes (Hallale et al. 2002). Hydrogen networks designed using data for one set of process conditions i.e. a single-period data, may not be able to satisfy the requirements of hydrogen consuming processes when the operating conditions of one or more refinery processes are changed. The methodology developed in this work is an extension of automated design approach of Liu (2002) for multiple periods of operation and can provide retrofit and design of flexible hydrogen networks that can operate under different operating conditions with minimum overall costs.

3.1 Multi-period hydrogen network model constraints

The design of hydrogen networks requires the process constraints to be satisfied for all the sources and sinks of a system. The process constraints are the overall material and hydrogen balance. All other constraints such as for compressors, purification units, piping system to connect sources and sinks, and pressure constraints are handled similar to the automated design approach. A comprehensive account of the modelling equations can be found elsewhere (Liu, 2002).

3.2 Design and optimisation strategy

The multi-period hydrogen network design and optimisation is a mixed integer non-linear programming (MINLP) problem with continuous variables such as flow rates and purities for each operating period and binary variables indicating the existence of units such as compressors, purification units and piping connections. A linear relaxation methodology (Quesada and Grossmann, 1995) is used to transform the problem into a mixed integer linear programming problem for which a global optimum can be obtained. The solution of this mixed integer linear programming formulation is employed as an initialisation of the original MINLP formulation. In this way the convergence to a feasible solution is guaranteed and the probability of obtaining a good local optimum solution is improved.

4. Case study

In this section a case study is presented to elaborate the need and strengths of the methodology developed for multi-period hydrogen management. The objective of this case study is to design a flexible hydrogen network that would have a lower overall cost, compared to single period hydrogen network design, and would satisfy the demands of hydrogen consuming processes for all the periods of operation under consideration. The process data for the refinery configuration is classified as source and sink data and is shown in Table 1 and Table 2.

It should be noted here that some refinery processes with minor hydrogen consumptions have been represented as a combined process sink “CPROC”. It can be seen from Table 1 that diesel hydrotreating unit is largest hydrogen consumer and may cause a bottleneck for any expansion that may require additional hydrogen consumption.

The hydrogen pinch analysis indicates that a reduction of 3.42 t/h of hydrogen gas stream flow rate is possible in the catalytic reformer, which is the hydrogen producer for the system under consideration.

Table 1 Net hydrogen sink data.

Unit	Flow rate (t/h)	Purity (mass fraction)	Pure H ₂ Flow (t/h)
NHT	3.108	0.262	0.815
RHT	5.081	0.2624	1.333
HC	3.251	0.2624	0.853
DHT	25.798	0.2015	5.198
ISOM	5.913	0.2596	1.535
CPROC	2.53494	0.2624	0.665
CCR fuel	0.446	0.2624	0.117

Sun (2004) demonstrated that the available surplus hydrogen can be optimally utilised for blending 5 volume % of light cycle oil in the diesel hydrotreater feed.

Table 2 Net hydrogen source data.

Unit	Flow rate (t/h)	Purity (mass fraction)	Pure H ₂ Flow (t/h)
CCR	16.73	0.2624	4.39
NHT	2.24	0.2857	0.64
RHC	4.95	0.2436	1.21
HC	3.16	0.2436	0.77
DHT	18.79	0.1802	3.38
ISOM	4.58	0.2588	1.18

This change in the diesel hydrotreater feed increases the net sink requirement of the diesel hydrotreating process to 27.798 t/h and consumes the surplus hydrogen that was originally available in the refinery hydrogen distribution system under consideration.

In this case study first a hydrogen network would be designed based on this new scenario, with increased diesel hydrotreating process hydrogen consumption, using the automated design approach which can only handle single period operating conditions. A multi-period hydrogen network would then be designed for the same refinery configuration using the methodology developed in this work and compared with automated design approach to elucidate the advantages of multi-period hydrogen network design.

The economic data for this case study e.g. the capital and operating cost data for compressors, piping system etc. has been taken from Liu (2002). The total annualised cost obtained for the design using automated design approach is 147.3 MM \$US/yr. The capital cost consists of the investment for installation of compressors and piping system while the operating cost consists of the power tariff and cost of hydrogen from the catalytic reforming unit.

The impact of catalyst deactivation on the process conditions of diesel hydrotreating unit is predicted using a molecular reaction model (Sun, 2004). The operating conditions of diesel hydrotreating process have been classified into three operating periods based on catalyst life. The changing hydrogen consumption of diesel hydrotreating process results into different net source flows i.e. the recycle and purge flows available from the diesel hydrotreating unit are different for different operating periods.

The net source flow rate available from the diesel hydrotreating process increases in the second and third operating periods. This change results in additional pure hydrogen flow of 0.187 t/h that can be utilised to improve hydrogen allocation in later operating periods (Ahmad, 2008). The single-period hydrogen network design approaches can not handle such considerations and usually result in excess hydrogen being sent to the fuel system or to be flared eventually.

The multi-period hydrogen network design obtained using the proposed methodology is shown in Figure 1. A comparison of the cost breakdown for this flexible hydrogen network design with the single-period design obtained using automated design approach is shown in Table 3.

Table 3 A comparison of cost breakdown between the hydrogen network designs.

	Single-period hydrogen network design	Multi-period hydrogen network design
Operating cost (MM \$US/yr)	133.508	123.304
Hydrogen cost	130.309	118.551
Electricity	3.198	4.753
Capital cost (MM \$US)	49.901	56.908
Compressors	43.535	47.897
Piping	6.365	9.010
TAC (MM \$US/yr)	147.305	136.450

The optimum hydrogen network design obtained using the multi-period formulation has a total annualised cost of 136.45 MM \$US/yr and results in a saving of 10.86 MM \$US/yr corresponding to a reduction of 7.4% in the total annualised cost.

5. Conclusions

Hydrogen management is essential for efficient economic operation of refineries. The multi-period hydrogen network design approach developed in this work addresses the simplifying assumption of constant operating conditions of refinery processes for hydrogen network design. The new methodology can handle changes in operating conditions of refinery processes and provides flexible hydrogen networks that can operate under multiple periods of operation with minimum overall costs.

NOMENCLATURE

CCR	continuous catalytic reformer
CPROC	combined process sink
DHT	diesel hydrotreater
HC	hydrocracker unit
ISOM	isomerisation process
MINLP	mixed integer non-linear programming
NHT	naphtha hydrotreater
TAC	total annualized cost

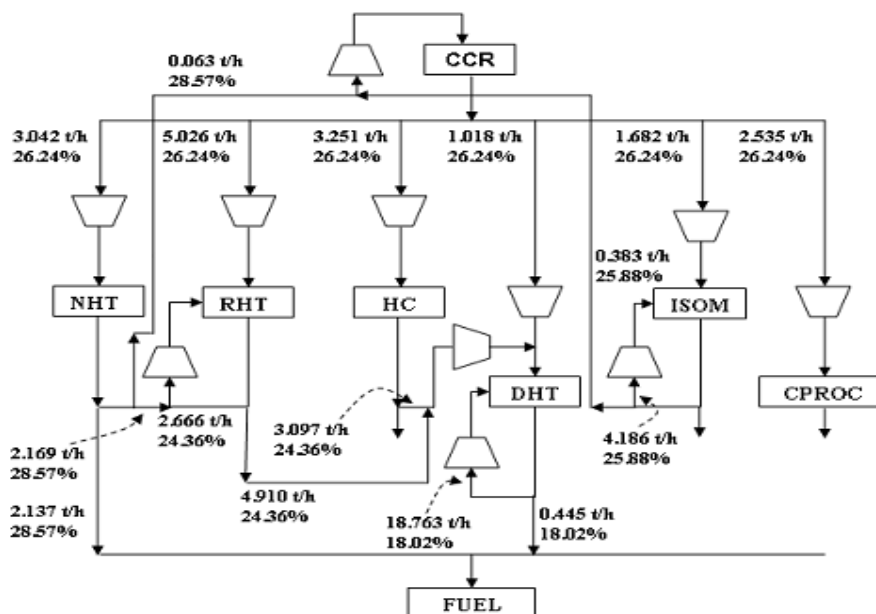

Figure 1 Flexible hydrogen network design obtained using multi-period hydrogen management.

ACKNOWLEDGEMENT

Ahmad acknowledges the financial support from N.W.F.P University of Engineering & Technology Peshawar and European Community EMINENT2 project TREN/05/FP6EN/S07.56209/019886.

References

- Ahmad, M.I., 2008, Multi-period aspects of hydrotreating process design, PIRC meeting, Manchester.
- Alves, J.J., 1999, Analysis and design of refinery hydrogen distribution systems, PhD thesis, Department of Process Integration, UMIST.
- Hallale, N., Moore, I., Vauk, D., 2002, Hydrogen: Liability or asset?, Chem. Eng. Prog. 98(9), 66-75.
- Liu, F., 2002, Hydrogen integration in oil refineries, PhD thesis, Department of process integration, UMIST.
- Peramanu, S., Cox, B.G., Pruden, B.B., 1999, Economics of hydrogen recovery processes for the purification of hydroprocessor purge and off-gases, Int. J. Hyd. Energy. 24, 405-424.
- Quesada, I., Grossmann, I.E., 1995, Global optimisation of bilinear process networks with multi-component flows, Compt. Chem. Eng. 19(12), 1219-1242.
- Sun, J., 2004, Molecular modelling and integration analysis of hydroprocessors, PhD thesis, Department of process integration, UMIST.
- Towler, G.P., Mann, R., Serriere, A.J., Gabaude, C.M.D., 1996, Refinery hydrogen management: Cost analysis of chemically integrated facilities, Ind. Eng. Chem. Res. 35, 2378-2388.