

NUCLEAR MARINE PROPULSION

© M. Ragheb

7/20/2011

1. INTRODUCTION

Several trends may end up shaping the future of naval ship technology: the all electrical ship, stealth technology, littoral vessels and moored barges for power production. The all-electric ship propulsion concept was adopted for the future USA surface combatant power source. This next evolution or Advanced Electrical Power Systems (AEPS) involves the conversion of virtually all shipboard systems to electric power; even the most demanding systems, such as propulsion and catapults aboard aircraft carriers. It would encompass new weapon systems such as modern electromagnetic rail-guns and free electron lasers as well as flywheel and capacitive energy storage systems.

An all-electric ship is the CVN-21 next-generation USA Navy aircraft carrier, planned to replace the half-century-old USS Enterprise CVN-65. The CVN-21's new nuclear reactor not only will provide three times the electrical output of current carrier power plants, but also will use its integrated power system to run an Electro Magnetic Aircraft Launch System (EMALS) to replace the current steam-driven catapults, combined with an Electromagnetic Aircraft Recovery System (EARS).

Littoral vessels are designed to operate closer to the coastlines than existing vessels such as cruisers and destroyers. Their mission would be signal intelligence gathering, stealth insertion of Special Forces, mine clearance, submarine hunting and humanitarian relief missions. Unmanned Underwater Vehicles (UUVs) monitored by nuclear-powered Virginia-class submarines would use Continuous Active Sonar (CAS) arrays which release a steady stream of energy, the sonar equivalent of a flashlight and would be used to as robots to protect carrier groups and turning attacking or ambushing submarines from being hunters into being the prey.

The largest experience in operating nuclear power plants since the late 1950s has been in nuclear marine propulsion, particularly aircraft carriers (Fig. 1) and submarines. The nuclear powered vessels comprise about 40 percent of the USA Navy's combatant fleet, including the entire sea based strategic nuclear deterrent. All the USA Navy's operational submarines and over half of its aircraft carriers are nuclear-powered.

The USA Navy had as of 10 Nimitz-class carriers, one Enterprise-class carrier; to be retired, 18 Ohio-class missile boats; 14 carrying ballistic missiles, and 4 armed with cruise missiles, 44 Los Angeles class attack submarines, and 3 Seawolf class attack submarines; including the signal intelligence and special forces insertion special warfare designed USS Jimmy Carter. As of 2008 it operated 99 vessels powered by nuclear reactors including 10 nuclear powered aircraft carriers and 71 submarines. It has operated nuclear powered ships for more than 50 years. As of 2001, about 235 naval reactors had been built at a unit cost of about \$100 million for a submarine and \$200 million for an aircraft carrier reactor.

The main considerations here are that nuclear powered submarines do not consume oxygen like conventional power plants, and that they have large endurance or mission times before fuel resupply, limited only by the available food and air purification supplies on board. Surface

vessels equipped with nuclear plants have long refueling intervals and do not need to be accompanied by vulnerable fuel supply tankers .



Figure 1. Nuclear aircraft carrier USS Theodore Roosevelt, Nimitz Class CVN71, powered with two A4W (A for Aircraft carrier, 4 for fourth generation and W for Westinghouse) nuclear reactors with 100 MW of power each, crossing the Suez Canal, Egypt, during the first Gulf War, January 1991. Source: USA Navy.

By 2002, the USA Navy operated 53 attack submarines (SSN) and 18 ballistic missile submarines (SSBN). These used by 1999 about 129 nuclear reactors exceeding the number of commercial power plants at 108. The mission for nuclear powered submarines is being redefined in terms of signal intelligence gathering and special operations.

During World War II, submarines used diesel engines that could be run on the water surface, charging a large bank of electrical batteries. These could later be used while the submarine is submerged, until discharged. At this point the submarine had to resurface to recharge its batteries and become vulnerable to detection by aircraft and surface vessels.

Even though special snorkel devices were used to suck and exhaust air to the submarine shallowly submerged below the water's surface, a nuclear reactor provides it with a theoretical infinite submersion time. In addition, the high specific energy, or energy per unit weight of nuclear fuel, eliminates the need for constant refueling by fleets of vulnerable tankers following a fleet of surface or subsurface naval vessels. On the other hand, a single refueling of a nuclear reactor is sufficient for long intervals of time.

assigned

Initially, the General Electric (GE) Company was assigned to develop a liquid metal concept; and the Westinghouse Company, a pressurized water concept. Each company built an AEC-owned and -financed nuclear development laboratory. Westinghouse purchased the original site of the Allegheny County Airport in a suburb of Pittsburgh, Pennsylvania for what became known as the Bettis Atomic Power Laboratory. GE built the Knolls Atomic Power Laboratory in New York.

The Westinghouse program produced results first. Using pressurized water as the coolant showed how corrosive hot water could be on the metal cladding surrounding the fuel. Westinghouse discovered that pure zirconium resisted such corrosion. Westinghouse built its own facility to produce it. The pure metal initially formed the cladding for the fuel elements to be later replaced by a zirconium alloy, Zircaloy that improved its performance.

With a high enrichment level of 93 percent, capable of reaching 97.3 percent in U^{235} , naval reactors, are designed for a refueling after 10 or more years over their 20-30 years lifetime, whereas land based reactors use fuel enriched to 3-5 percent in U^{235} , and need to be refueled every 1-1 1/2 years period. New cores are designed to last 50 years in carriers and 30-40 years in submarines, which is the design goal of the Virginia class of submarines.

Burnable poisons such as gadolinium or boron are incorporated in the cores. These allow a high initial reactivity that compensates for the build up of fission products poisons over the core lifetime, as well as the need to overcome the reactor dead time caused by the xenon poison changes as a result of operation at different power levels.

Naval reactors use high burn up fuels such as uranium-zirconium, uranium-aluminum, and metal ceramic fuels, in contrast to land-based reactors which use uranium dioxide UO_2 . These factors provide the naval vessels theoretical infinite range and mission time. For these two considerations, it is recognized that a nuclear reactor is the ideal engine for naval propulsion.

A compact pressure vessel with an internal neutron and gamma ray shield is required by the design while maintaining safety of operation. Their thermal efficiency is lower than the thermal efficiency of land based reactors because of the emphasis on flexible power operation rather than steady state operation, and of space constraints.

Reactor powers range from 10 MWth in prototypes to 200 MWth in subsurface vessels, and 500 MWth in surface ships larger submarines. Newer designs use jet pump propulsion instead of propellers, and aim at an all electrical system design, including the weapons systems such as electromagnetic guns.

2. NUCLEAR NAVAL VESSELS

Jules Verne, the French author in his 1870 book: "20,000 Leagues Under the Sea," related the story of an electric submarine. The submarine was called the "Nautilus," under its captain Nemo. Science fiction became reality when the first nuclear submarine built by the USA Navy was given the same name. Figure 2 shows a photograph of the Nautilus, the first nuclear powered submarine.

Construction of the Nautilus (SSN-571) started on June 14, 1952, its first operation was on December 30, 1954 and it reached full power operation on January 13, 1955. It was commissioned in 1954, with its first sea trials in 1955. It set speed, distance and submergence records for submarine operation that were not possible with conventional submarines. It was the

first ship to reach the North Pole. It was decommissioned in 1980 after 25 years of service, 2,500 dives, and a travelled distance of 513,000 miles. It is preserved at a museum at Croton, Connecticut.



Figure 2. The "Nautilus", the first nuclear powered submarine.

Figure 3 shows the experimental setup S1W prototype for the testing of the Nautilus's nuclear reactor built at the Idaho National Laboratory (INL) in 1989. The section of the hull containing the reactor rested in a "sea tank" of water 40 feet deep and 50 feet in diameter. The purpose of the water was to help shielding specialists study "backscatter," radiation that might escape the hull, bounce off the water molecules, and reflect back into the living quarters of the ship.

The advantage of a nuclear engine for a submarine is that it can travel long distances undetected at high speed underwater avoiding the surface wave resistance, without refueling. Unlike diesel engine driven submarines, the nuclear engine does not need oxygen to produce its energy.

The reactor for the Nautilus was a light water moderated, highly enriched in Uranium²³⁵ core, with zirconium clad fuel plates. The high fuel enrichment gives the reactor a compact size, and a high reactivity reserve to override the xenon poison dead time. The Nautilus beat numerous records, establishing nuclear propulsion as the ideal driving force for the world's submarine fleet. Among its feats was the first underwater crossing of the Arctic ice cap. It traveled 1,400 miles at an average speed of 20 knots. On a first core without refueling, it traveled 62,000 miles.

Zirconium has a low neutron absorption cross section and, like stainless steel, forms a protective, invisible oxide film on its surface upon exposure to air. This oxide film is composed of zirconia or ZrO_2 and is on the order of only 50 to 100 angstroms in thickness. This ultra thin oxide prevents the reaction of the underlying zirconium metal with virtually any chemical reagent under ambient conditions. The only reagent that will attack zirconium metal at room temperature is hydrofluoric acid, HF, which will dissolve the thin oxide layer off of the surface

of the metal and thus allow HF to dissolve the metal itself, with the concurrent evolution of hydrogen gas.

Another nuclear submarine, the Triton reenacted Magellan's trip around the Earth. Magellan traveled on the surface, while the Triton did it completely submerged.

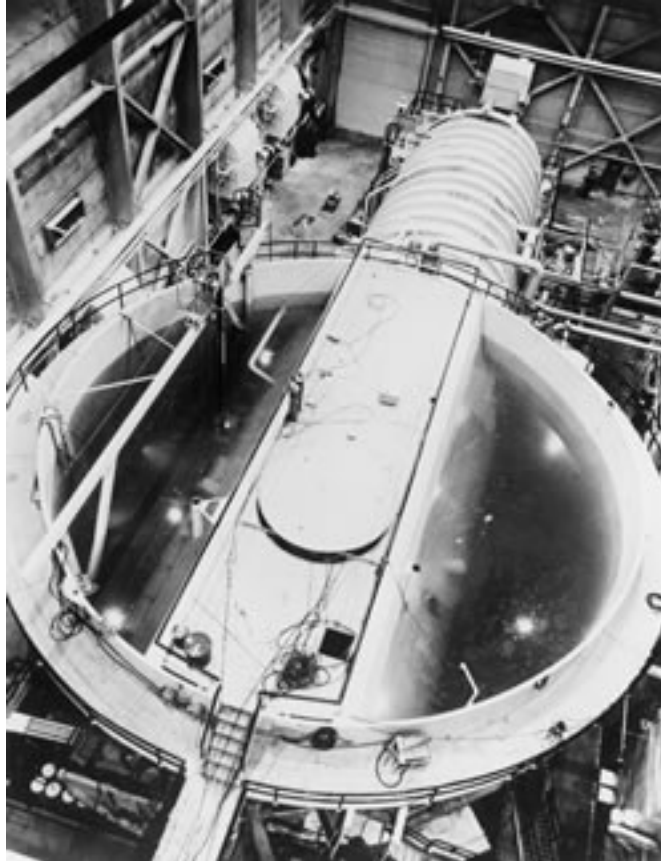

Figure 3. Experimental setup for testing Nautilus type naval reactors at the Idaho National Engineering Laboratory, INEL, 1989.

3. NAVAL REACTOR DEVELOPMENT

INTRODUCTION

There have been more reactor concepts investigated in the naval propulsion area by different manufacturers and laboratories than in the civilian field, and much can be learned from their experience for land applications.

According to the type of vessel they power they have different first letter designations: A for Aircraft carrier, C for Cruiser, D for Destroyer or Cruiser and S for Submarine.

They are also designated with a last letter according to the designer institution or lead laboratory: B for Bechtel, C for Combustion Engineering, G for General Electric and W for Westinghouse.

A middle number between the first and last letter refers to the generation number of the core design. For instance, the A1B is the first generation of a core design for aircraft carriers with Bechtel operating the lead laboratory for the design.

Naval reactors designs use boron as a burnable neutron poison. The fuel is an alloy of 15 percent zirconium and 85 percent uranium enriched to a level of 93 percent in U^{235} . The burnable poisons and high enrichment allow a long core lifetime and provides enough reactivity to overcome the xenon poisoning reactor dead time. The vertical direction doping provides a long core life, and the radial doping provides for an even power and fuel burnup distribution.

STR OR S1W PRESSURIZED WATER REACTOR DESIGN

The Westinghouse Electric Corporation under contract to the USA Navy constructed, tested and operated a prototype pressurized water reactor submarine reactor plant. This first reactor plant was called the Submarine Thermal Reactor, or STR. On March 30, 1953, the STR was brought to power for the first time and the age of naval nuclear propulsion was born. In 1953 it achieved a 96 hours sustained full power run simulating a crossing of the Atlantic Ocean. The second S1W core sustained in 1955 a 66 days continuous full power simulating a high speed run twice around the globe.

The STR was redesigned as the first generation submarine reactor S1W, which became critical on March 30, 1953, was the prototype of the USS Nautilus (SSN 571) reactor and was followed in the middle to late 1950s by the Aircraft carrier A1W, the prototype of the aircraft carrier USS Enterprise plant.

Westinghouse's Bettis Atomic Power Laboratory was assigned the responsibility for operating the reactor it had designed and built, hence the W in the name. The crew was increasingly augmented by naval personnel as the cadre of trained operators grew

The fuel elements are sandwich plates made of U and Zr and clad in Zr. The maximum temperature in the fuel was 645 °F and the sheath temperature was 551 °F with an average cycle time of 600 hours or just $600 / 24 = 25$ days. The reactor temperature is limited by the pressure needed to prevent boiling, necessitating high pressure vessels, piping and heat exchangers. The steam was generated at a relatively low pressure. A high level of pumping power was required, and the fuel was costly. However this design had few hazards, has been proven in service, and an expensive moderator was not needed.

The S1C reactor used an electric drive rather than a steam turbine like in the subsequent S5W reactor design rated at 78 MWth and a 93 percent U^{235} enriched core that was the standard in the 1970s. The S6G reactor plant was rated at 148 MWth and the D2W core was rated at 165 MWth.

The S6G reactor is reported to be capable of propelling a Los Angeles class submarine at 15 knots or 27.7 km/hr when surfaced and 25 knots or 46.3 km/hr while submerged.

The Sea wolf class of submarines was equipped with a single S6W reactor, whereas the Virginia class of submarines is expected to be equipped with an S9G reactor.

The higher achievable submerged speed is due to the absence of wave friction underwater suggesting that submarine cargo ships would offer a future energy saving alternative to surface cargo ships.

LARGE SHIP REACTORS, A1W-A, A1W-B PROTOTYPE PLANTS

The A1W (aircraft carrier, first prototype, Westinghouse) plant consisted of a pair of prototype reactors for the USS Enterprise USA Navy nuclear-powered aircraft carrier. Located at the Naval Reactors Facility, the two pressurized-water reactors (designated A and B) were built within a portion of a steel hull. The plant simulated the Enterprise's engine room. All components could withstand seagoing use.

The A1W plant was the first in which two reactors powered one ship propeller shaft through a single-gear turbine propulsion unit. As the Navy program evolved, new reactor cores and equipment replaced many of the original components. The Navy trained naval personnel at the A1W plant and continued a test program to improve and further develop operating flexibility.

The A1W prototype plant was started in 1956 for surface ships using two pressurized water reactors. The plant was built as a prototype for the aircraft carrier USS Enterprise (CVN 65), which was the first nuclear-powered aircraft carrier. Power operation of the A1W plant started in October of 1958.

In the A1W and A2W designs, the coolant was kept at a temperature between 525-545 °F or 274-285 °C. In the steam generators, the water from the feed system is converted to steam at 535 °F or 279 °C and a pressure of about 600 psi or 4 MPa. The reactor coolant water was recirculated by four large electric pumps for each reactor.

The steam was channeled from each steam generator to a common header, where the steam is then sent to the main engine, electrical generators, aircraft catapult system, and various auxiliaries. The main propulsion turbines are double ended, in which the steam enters at the center and divides into two opposing streams.

The main shaft was coupled to a reduction gear in which the high rotational velocity of the turbine shaft is stepped down to a usable turn rate for propelling the ship.

In the A3W reactor design used on the USS John F. Kennedy a 4 reactor design is used. In the A4W design with a life span of 23 years on the Nimitz class carriers only two reactors per ship are used with each providing 104 MWth of power or 140,000 shaft HP. The A1B is also a two reactor design for the Gerald R. Ford class of carriers.

SIR OR S1G INTERMEDIATE FLUX BERYLLIUM SODIUM COOLED REACTOR

This reactor design was built by the General Electric (GE) Company, hence the G designation. The neutron spectrum was intermediate in energy. It used UO₂ fuel clad in stainless steel with Be used as a moderator and a reflector. The maximum temperature in the fuel could reach 1,700 +/- 300 °F with a maximum sheath temperature of 900 °F, with a cycle time of 900 hours or $900 / 24 = 37.5$ days.

A disadvantage is that the coolant becomes activated with the heat exchangers requiring heavy shielding. In addition Na reacts explosively with water and the fuel element removal is problematic. On the other hand high reactor and steam temperatures can be reached with a higher thermal efficiency. A low pressure is used in the primary system.

Beryllium has been used as a moderator in the Sea Wolf class of submarines reactors. It is a relatively good solid moderator, both from the perspectives of slowing down power and of the moderating ratio, and has a very high thermal conductivity. Pure Be has good corrosion

resistance to water up to 500 °F, to sodium to 1,000 °F, and to air attack to 1,100 °F. It has a noted vapor pressure at 1,400 °F and is not considered for use much above 1,200 °F even with an inert gas system. It is expensive to produce and fabricate, has poor ductility and is extremely toxic necessitating measures to prevent inhalation and ingestion of its dust during fabrication.

A considerably small size thermal reactor can be built using beryllium oxide as a moderator. It has the same toxicity as Be, but is less expensive to fabricate. It can be used with a sodium cooled thermal reactor design because BeO is corrosion resistant to sodium. It has similar nuclear properties to Be, has a very high thermal conductivity as a ceramic, and has a good resistance to thermal shock. It can be used in the presence of air, Na and CO₂. It is volatile in water vapor above 1,800 °F. In its dense form, it resists attack by Na or Na-K at a temperature of 1,000 °F. BeO can be used as a fuel element material when impregnated with uranium. Low density increases its resistance to shock. A BeO coating can be applied to cut down on fission products release to the system.

The USS Seawolf submarine, initially used a Na cooled reactor that was replaced in 1959 by a PWR to standardize the fleet, because of superheater bypass problems causing mediocre performance and as a result of a sodium fire. The steam turbines had their blades replaced to use saturated rather than superheated steam. The reactor was housed in a containment vessel designed to contain a sodium fire.

The eighth generation S8G reactor was capable of operating at a significant fraction of full power without reactor coolant pumps. The S8G reactor was designed by General Electric for use on the Ohio class (SSGN/SSBN-726) submarines. A land based prototype of the reactor plant was built at Knolls Atomic Power Laboratory at Ballston Spa, New York. The prototype was used for testing and crew training throughout the 1980s. In 1994, the core was replaced with a sixth generation S6W Westinghouse reactor, designed for the Sea Wolf class submarines.

EXPERIMENTAL BERYLLIUM OXIDE REACTOR, EBOR

The Experimental Beryllium Oxide Reactor's objective was to develop beryllium oxide as a neutron moderator in high-temperature, gas-cooled reactors. The project was canceled in 1966 before construction was complete.

Among the reasons for the cancellation was the encouraging progress achieved, concurrent with EBOR construction, in developing graphite as a moderator. This reduced the importance of developing beryllium oxide as an alternate.

No uranium fuel ever was loaded into the Experimental Beryllium Oxide reactor and it never operated or went critical before the program was canceled. It was "a reactor," but never an operating one.

SC-WR SUPER CRITICAL WATER REACTOR

The Super Critical Water Reactor (SC-WR) was considered with an intermediate energy neutron spectrum. The fuel was composed of UO₂ dispersed in a stainless steel matrix. It consisted of 1 inch square box with parallel plates and sine wave filters with a type 347 stainless steel cladding 0.007 inch thick. The maximum temperature in the fuel reached 1,300 °F with an average cycle time of 144 hours or $144 / 24 = 6$ days.

The materials for high pressure and temperature and the retention of mechanical seals and other components were a service problem.

The water coolant reached a pressure of 5,000 psi. The high pressure and temperature steam results in a high cycle efficiency, small size of the reactor with no phase change in the coolant.

ORGANIC MODERATED REACTOR EXPERIMENT, MORE

The Organic Cooled and Moderated Reactor has been considered as a thermal neutron spectrum shipboard power plant.

The waxy coolant was considered promising because it liquified at high temperatures but didn't corrode metal like water did.

Also, it operated at low pressures, significantly reducing the risk of leaking. A scaled-up reactor, the Experimental Organic Cooled Reactor, was built next door in anticipation of further development of the concept.

The rectangular-plates fuel clad in aluminum can be natural uranium since the Terphenyl organic coolant can have good moderating properties. The cladding temperature can reach 800 °F with an average cycle time of 2,160 hours or $2,160 / 24 = 90$ days.

The overall heat transfer coefficient of the coolant is low with the formation of polymers under irradiation that require a purification system. The advantages are negligible corrosion and the achievement of low pressure at a high temperature.

A diphenyl potential coolant broke down under irradiation. The hydrogen in the compound turned into a gas forming bubbles. The bubbles reduced the moderator density and made it difficult to maintain the chain reaction. The initially clear liquid turned into a gummy and black breakup product.

No uranium fuel ever was loaded into the reactor and it never operated or went critical before the program was canceled. It was "a reactor," but never "an operating reactor."

LEAD-BISMUTH COOLED FAST REACTORS

The alpha class of Russian submarines used an alloy of Pb-Bi 45-50 percent by weight cooled fast reactors. The melting point of this alloy is 257 °F. They faced problems of corrosion of the reactor components, melting point, pump power, polonium activity and problems in fuel unloading.

Refueling needed a steam supply to keep the liquid metal molten. Bismuth leads to radiation from the activated products, particularly polonium. An advantage is that at decommissioning time, the core can be allowed to cool into a solid mass with the lead providing adequate radiation shielding.

This class of submarines has been decommissioned.

NATURAL CIRCULATION S5G PROTOTYPE

The S5G was the prototype of a pressurized-water reactor for USS Narwhal. Located at the Naval Reactors Facility, it was capable of operating in either a forced or natural circulation flow mode. In the natural circulation mode, cooling water flowed through the reactor by thermal

circulation, not by pumps. Use of natural circulation instead of pumps reduced the noise level in the submarine.

To prove that the design concept would work in an operating ship at sea, the prototype was built in a submarine hull section capable of simulating the rolling motion of a ship at sea.

The S5G continued to operate as part of the Navy's nuclear training program until that program was reduced after the end of the Cold War.

The S5G reactor had two coolant loops and two steam generators. It had to be designed with the reactor vessel situated low in the boat and the steam generators high in order for natural circulation of the coolant to be developed and maintained.

This nuclear reactor was installed both as a land-based prototype at the Nuclear Power Training Unit, Idaho National Engineering Laboratory near Idaho Falls, Idaho, and on board the USS Narwhal (SSN-671), now decommissioned.

The prototype plant in Idaho was given a rigorous performance check to determine if such a design would work for the USA Navy. It was largely a success, although the design never became the basis for any more fast attack submarines besides the Narwhal. The prototype testing included the simulation of essentially the entire engine room of an attack submarine. By floating the plant in a large pool of water, the whole prototype could be rotated along its long axis to simulate a hard turn. This was necessary to determine whether natural circulation would continue even during hard maneuvers, since natural circulation is dependent on gravity.

The USS Narwhal had the quietest reactor plant in the USA naval fleet. Its 90 MWth reactor plant was slightly more powerful than the other fast attack USA nuclear submarines of that era such as the third generation S3G and the fifth generation S5W. The Narwhal contributed significantly to the USA effort during the Cold War. With its quiet propulsion and the pod attached to its hull, it used a towed sonar array and possibly carried a Remotely Operated Vehicle (ROV) for tapping into communication cables and maintaining a megaphones tracking system at the bottom of the oceans.

It was intended to test the potential contribution of natural circulation technology to submarine noise suppression by the avoidance of forced flow pump cooling. The reactor primary coolant pumps are one of the primary sources of noise from submarines in addition to the speed reduction gearbox and cavitation from the propeller. The elimination of the coolant pumps and associated equipment would also reduce mechanical complexity and the space required by the propulsion equipment.

The S5G was the direct precursor to the eighth generation S8G reactor used on the Ohio class ballistic missile submarines; a quiet submarine design.

The S5G was also equipped with coolant pumps that were only needed in emergencies to attain high power and speed. The reactor core was designed with very smooth paths for the coolant. Accordingly, the coolant pumps were smaller and quieter than the ones used by the competing S5W core, a Westinghouse design. They were also fewer in numbers. In most situations, the submarine could be operated without using the coolant pumps, useful for stealth operation. The reduction in electrical requirements enabled this design to use only a single electrical turbine generator plant.

The S8G prototype used natural circulation allowing operation at a significant fraction of full power without using the reactor pumps, providing a silent stealth operation mode.

To further reduce engine plant noise, the normal propulsion setup of two steam turbines driving the propeller screw through a reduction gear unit was changed instead to one large

propulsion turbine without reduction gears. This eliminated the noise from the main reduction gears, but at the expense of a large main propulsion turbine. The turbine was cylindrical, about 12 feet in diameter and 30 feet in length. This large size was necessary to allow it to turn slowly enough to directly drive the screw and be fairly efficient in doing so. The same propulsion setup was used on both the USS Narwhal and its land based prototype.

FAIL SAFE CONTROL AND LOAD FOLLOWING S7G DESIGN

The S7G core was controlled by stationary gadolinium clad tubes that were partially filled with water. Water was pumped from the portion of the tube inside the core to a reservoir above the core, or allowed to flow back down into the tube. A higher water level in the tube within the core slowed down the neutrons allowing them to be captured by the gadolinium tube cladding rather than the uranium fuel, leading to a lower power level.

The system had a fail safe control system. The pump needed to run continually to keep the water level pumped down. Upon an accidental loss of power, all the water would flow back into the tube, shutting down the reactor.

This design also had the advantage of a negative reactivity feedback and a load following mechanism. An increase in reactor power caused the water to expand to a lower density lowering the power. The water level in the tubes controlled average coolant temperature, not reactor power. An increase in steam demand resulting from opening the main engines throttle valves would automatically increase reactor power without action by the operator.

S9G HIGH ENERGY DENSITY CORE

The S9G is a PWR built by General Electric with increased energy density, and new plant components, including a new steam generator design featuring improved corrosion resistance and a reduced life cycle cost. This reactor in the Virginia class SSN-774 submarines is designed to operate for 33 years without refueling and last the expected 30 year design life of a typical submarine. It produces about 40,000 shaft horsepower, or about 30 MW of power.

The higher power density decreases not only size but also enhances quiet operation through the elimination of bulky control and pumping equipment. It would be superior to any Russian design from the perspective of noise reduction capability, with 30 units planned to be built.

Table 1. Power ratings of naval reactor designs.

Reactor type	Rated power	
	shaft horse power, [shp]	[MW]*
A2W	35,000	26.1
A4W/A1G	140,000	104.4
C1W	40,000	29.8
D2G	35,000	26.1
S5W	15,000	11.2
S5G	17,000	12.7

S6W	35,000	26.1
S8G	35,000	26.1
S9G	40,000	29.8

*1 shp = 745.6999 Watt = 0.7456999 kW

EXPENDED CORE FACILITY, ECF

The Expended Core Facility was built in 1957. It was used to examine expended naval reactor fuel to aid in the improvement of future generations of naval reactors. In the middle 1960s, the fifth generation S5G, the prototype of the submarine USS Narwhal reactor, and predecessor to the reactor plant used to propel the Trident Fleet Ballistic Missile Submarines, was built and placed in service by the General Electric Company.

The Expended Core Facility ECF was built to examine and test fuel from nuclear powered vessels, prototype plants, and the Shippingport Power Plant. It has examined specimens of irradiated fuel that were placed in a test reactor, such as the Advanced Test Reactor (ATR).

The information from detailed study of this fuel has enabled the endurance of naval nuclear propulsion plants to be increased from two years for the first core in Nautilus to the entire 30+ year lifetime of the submarines under construction today.

It originally consisted of a water pool and a shielded cell with a connecting transfer canal. It has been modified by the addition of three more water pools and several shielded cells. The water pools permit visual observation of naval spent nuclear fuel during handling and inspection while shielding workers from radiation. The shielded cells are used for operations which must be performed dry.

NAVAL REACTORS RESEARCH AND DEVELOPMENT

The USA Navy's research and development expanded in eastern Idaho, and by late 1954, the Nuclear Power Training Unit was established. In 1961, the Naval Administrative Unit set up shop in Blackfoot. In 1965, the unit moved to a location at Idaho Falls

In the early 1950s work was initiated at the Idaho National Engineering and Environmental Laboratory (INEEL) to develop reactor prototypes for the USA Navy. The Naval Reactors Facility, a part of the Bettis Atomic Power Laboratory, was established to support development of naval nuclear propulsion. The facility was operated by the Westinghouse Electric Corporation under the direct supervision of the DOE's Office of Naval Reactors. The facility supports the Naval Nuclear Propulsion Program by carrying out assigned testing, examination, and spent fuel management activities.

The facility consisted of three naval nuclear reactor prototype plants, the Expended Core Facility, and various support buildings. The Submarine Thermal Reactor (STR) prototype was constructed in 1951 and shut down in 1989; the large ship reactor prototype was constructed in 1958 and shut down in 1994; and the submarine reactor plant prototype was constructed in 1965 and shut down in 1995.

The prototypes were used to train sailors for the nuclear navy and for research and development purposes. The Expended Core Facility, which receives, inspects, and conducts research on naval nuclear fuel, was constructed in 1958.

The initial power run of the prototype reactor (S1W) as a replacement of the STR for the first nuclear submarine, the Nautilus, was conducted at the INEEL Laboratory in 1953. The A1W prototype facility consisted of a dual-pressurized water reactor plant within a portion of the steel hull designed to replicate the aircraft carrier Enterprise. This facility began operations in 1958 and was the first designed to have two reactors providing power to the propeller shaft of one ship. The S5G reactor was a prototype pressurized water reactor that operated in either a forced or natural circulation flow mode. Coolant flow through the reactor was caused by natural convection rather than pumps. The S5G prototype plant was installed in an actual submarine hull section capable of simulating the rolling motions of a ship at sea.

The Test Reactor Area (TRA) occupied 102 acres in the southwest portion of the INEEL laboratory. The TRA was established in the early 1950s with the development of the Materials Test Reactor (MTR). Two other major reactors were subsequently built at the TRA: the Engineering Test Reactor (ETR) and the Advanced Test Reactor (ATR). The Engineering Test Reactor has been inactive since January 1982. The Materials Test Reactor was shut down in 1970.

The major program at the TRA became the Advanced Test Reactor. Since the Advanced Test Reactor achieved criticality in 1967, it was used almost exclusively by the Department of Energy's Naval Reactors Program. After almost 30 years of operation, it is projected to remain a major facility for research, radiation testing, and isotope production into the next century.

The Navy makes shipments of naval spent fuel to INEEL that are necessary to meet national security requirements to defuel or refuel nuclear powered submarines, surface warships, or naval prototype or training reactors, or to ensure examination of naval spent fuel from these sources. The total number of shipments of naval spent fuel to INEEL through 2035 would not exceed 575 shipments or 55 metric tonnes of spent fuel.

4. COMMERCIAL NUCLEAR SHIPS:

The USA built one single nuclear merchant ship: the Savannah. It is shown in Fig. 4. It was designed as a national showpiece, and not as an economical merchant vessel. Figure 5 shows the design of its nuclear reactor. For compactness, the steam generators and steam drums surround the reactor core. This configuration also provides shielding for the crew. It was retired in 1970.

The 630-A reactor, a low-power critical experiment, was operated at the Idaho National Laboratory (INL) to explore the feasibility of an air-cooled, water-moderated system for nuclear-powered merchant ships. Further development was discontinued in December 1964 when decisions were made to lower the priority of the entire nuclear power merchant ship program.

Nuclear Ice Breakers like the Russian Lenin and the Arktica were a good success, not requiring refueling in the arctic regions.

The Otto Hahn bulk ore carrier was built by Germany. It operated successfully for ten years.

The Mutsu was an oceanographic research vessel built in Japan in 1974. Due to a design flaw causing a radiation leakage from its top radiation shield, it never became fully operational.

The Sturgis MH-1A was a floating nuclear power plant ship (Fig. 6). It was carrying a 45 Megawatts Thermal (MWth) Pressurized water Reactor (PWR) for remote power supplies for the USA Army.



Figure 4. The Savannah, the first USA merchant ship.

5. MARINE AND NAVAL REACTOR DESIGNS

The nuclear navy benefited the civilian nuclear power program in several ways. It first demonstrated the feasibility of the Pressurized Water Reactor (PWR) concept, which is being currently used in the majority of land based power reactors. Second, naval reactors accumulated a large number of operational experience hours, leading to improvements in the land based reactors. The highly trained naval operational crews also become of great value to the civilian nuclear utilities providing them with experienced staffs in the operation and management of the land based systems.

Land based reactors differ in many way from naval reactors. The power of land based reactors is in the range of 3,000 MWth or higher. In contrast, a submarine reactor's power is smaller in the range of the hundreds of MWths. Land based systems use uranium fuel enriched to the 3-5 percent range. Highly enriched fuel at the 93-97 percent level is used in naval reactors to provide enough reactivity to override the xenon poison dead time, compactness as well as provide higher fuel burnup and the possibility for a single fuel loading over the useful service time of the powered ship.

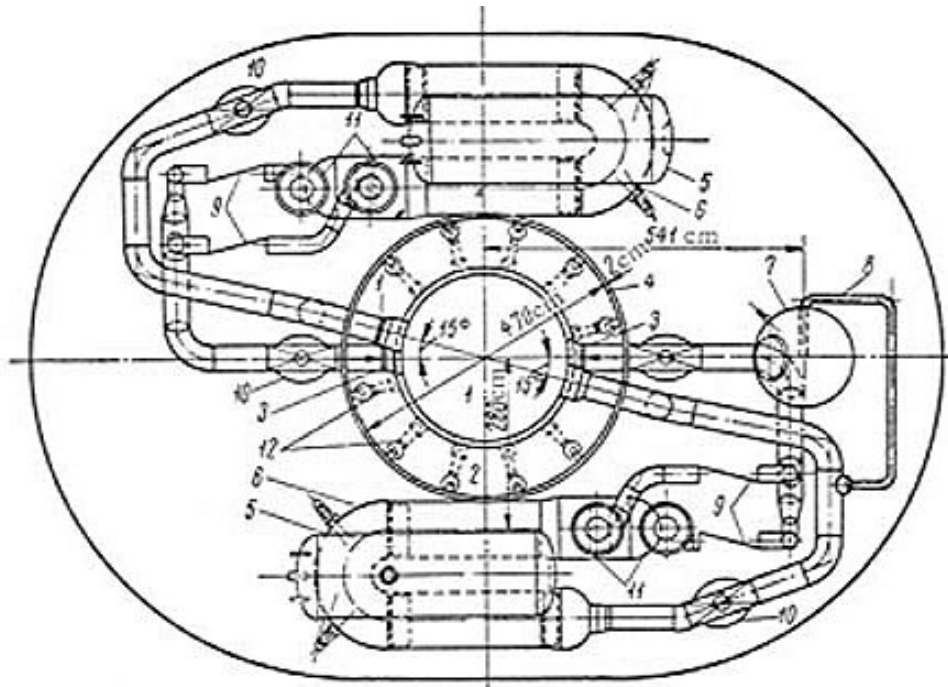

Figure 5. Loop type of naval reactor design for the nuclear ship Savannah. The reactor core is surrounded by the heat exchangers and the steam drums. The horizontal steam generator was replaced by a vertical tube steam generator and an integrated system in future designs. 1: Reactor core, 2: Water shield, 3: Coolant inlet, 4: Pb Shield layer, 5: Steam drum, 6: Heat exchanger, 7: Pressurizer, or volume compensator, 8: Equalizer line, 9: Cutoff channel, 10: Gate valve, 11: Coolant pumps, 12: Channels with apparatus [5].



Figure 6. The MH-1A Sturgis Floating Nuclear Power Plant for remote power applications for the USA Army.

Table 2 shows the composition of highly enriched fuel used in nuclear propulsion as well as space reactor designs such as the SAFE-400 and the HOMER-15 designs. Most of the activity is caused by the presence of U^{234} , which ends up being separated with the U^{235} component during the enrichment process. This activity is primarily alpha decay and does not account for any appreciable dose. Since the fuel is highly purified and there is no material such as fluorine or oxygen causing any (α , n) reactions in the fuel, the alpha decay of U^{234} does not cause a neutron or gamma ray dose. If uranium nitride (UN) is used as fuel, the interaction threshold energy of nitrogen is well above the alpha emission energies of U^{234} . Most of the dose prior to operation from the fuel is caused by U^{235} decay gammas and the spontaneous fission of U^{238} . The total exposure rate is 19.9 [μ Röntgen / hr] of which the gamma dose rate contribution is 15.8 and the neutron dose rate is 4.1.

Table 2. Composition of highly enriched fuel for naval and space reactors designs.

Isotope	Composition (percent)	Activity (Curies)	Decay Mode	Exposure Contribution [μ R/hr]
U^{234}	0.74	6.1	Alpha decay	unappreciable
U^{235}	97.00		Decay gammas	appreciable
U^{238}	2.259		Spontaneous fissions	appreciable
Pu^{239}	0.001		Alpha decay	unappreciable
Total		6.5		19.9

Reactor operators can wait for a 24 hours period; the reactor dead time, on a land based system for the xenon fission product to decay to a level where they can restart the reactor. A submarine cannot afford to stay dead in the water for a 24 hour period if the reactor is shutdown, necessitating highly enriched fuel. A nuclear submarine has the benefit of the ocean as a heat sink, whereas a land based reactor needs large amounts of water to be available for its safety cooling circuits

For these reasons, even though the same principle of operation is used for naval and land based reactor designs, the actual designs differ substantially. Earlier naval reactors used the loop type circuit for the reactor design as shown in Fig. 5 for the Savannah reactor. There exists a multitude of naval reactor designs. More modern designs use the Integral circuit type shown in Fig. 7.

Because of the weight of the power plant and shielding, the reactor and associated steam generation equipment is located at the center of the ship. Watertight bulkheads isolating the reactor components surround it. The greater part of the system is housed in a steel containment, preventing any leakage of steam to the atmosphere in case of an accident. The containment vessel for the Savannah design consisted of a horizontal cylindrical section of 10.7 meters diameter, and two hemispherical covers. The height of the containment was 15.2 meters. The control rod drives are situated in a cupola of 4.27 m in diameter, on top of the containment. The

containment vessel can withstand a pressure of 13 atm. This is the pressure attained in the maximum credible accident, which is postulated as the rupture of the primary loop and the subsequent flashing into steam of the entire coolant volume.

The secondary shielding consists of concrete, lead, and polyethylene and is positioned at the top of the containment. A prestressed concrete wall with a thickness of 122 cm surrounds the lower section of the containment. This wall rests on a steel cushion. The upper section of the secondary shielding is 15.2 cm of lead to absorb gamma radiation, and 15.2 cm of polyethylene to slow down any neutrons. The space between the lead plates is filled with lead wool. The lead used in the shielding is cast by a special method preventing the formation of voids and inhomogeneities.

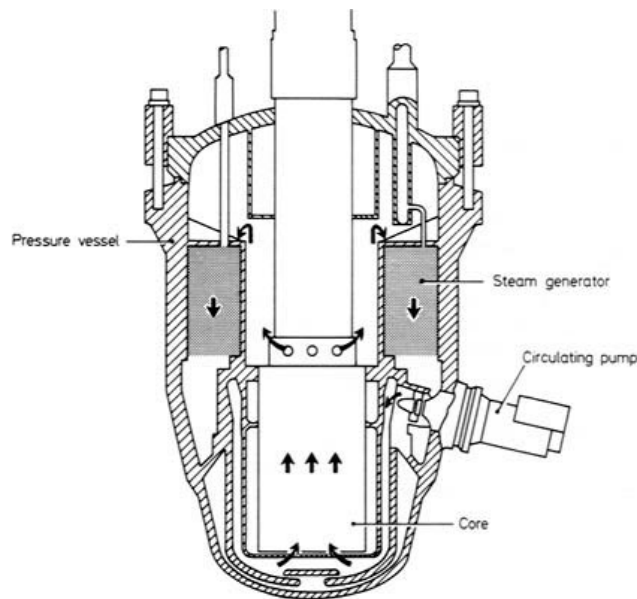

Figure 7. Integral type of naval reactor vessel [4].

The polyethylene sheets are spaced so as to allow thermal expansion. Thick collision mats consisting of alternate layers of steel and wood are placed on the sides of the containment. The effective dose rate at the surface of the secondary sheet does not exceed 5 rem/year.

The containment is airtight. Personnel can remain in it for up to 30 minutes after reactor shutdown and the radiation level would have fallen to less than 0.2 rem/hr.

The primary shielding is here made of an annular water tank that surrounds the reactor and a layer of lead attached to the outer surface of the tank, to minimize space. The height of the tank is 5.2 m, the thickness of the water layer, 84 cm, and the thickness of the lead is 5-10 cm.

The weight of the primary shields is 68.2 tons, and with the water it is 118.2 tons. The weight of the containment is 227 tons. The secondary shielding weighs 1795 tons consisting of: 561 tons of ordinary concrete, 289 tons of lead, 69 tons of polyethylene, and 160 tons of collision mats. The latter consist of 22 tons of wood and 138 tons of steel.

The shielding complex is optimized to minimize the space used, while providing low radiation doses to the crew quarters. It is comparatively heavy because of the use of lead and steel, and is complicated to install.

Figure 7 shows a naval reactor of the Integral circuit type. In this case, the design offers a substantial degree of inherent safety since the pumps; the steam generators and reactor core are all contained within the same pressure vessel. Since the primary circulating fluid is contained within the vessel, any leaking fluid would be contained within the vessel in case of an accident. This also eliminates the need for extensive piping to circulate the coolant from the core to the steam generators. In loop type circuits, a possibility exists for pipe rupture or leakage of the primary coolant pipes. This source of accidents is eliminated in an integral type of a reactor.

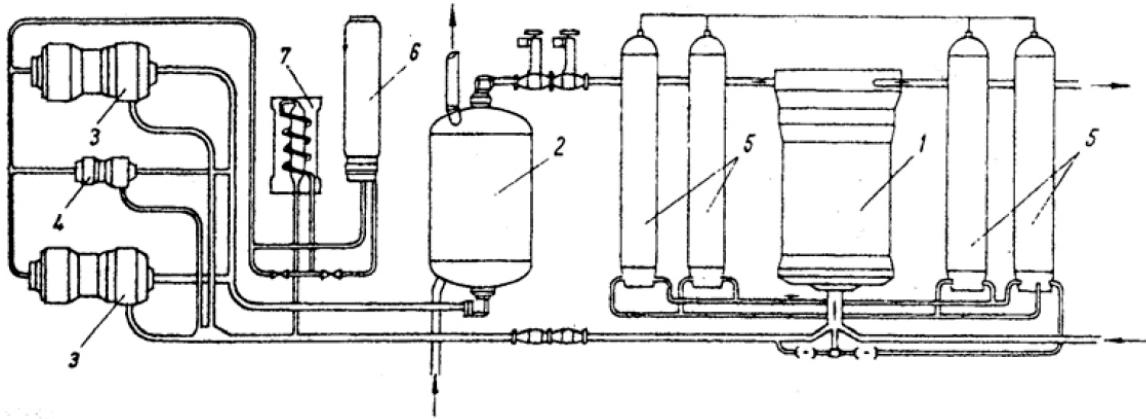

Figure 8. Components of OK-150 plant. 1: Reactor, 2: Steam generator, 3: Main circulation pumps, 4: Emergency cooling pump, 5: Pressurizers, 6: Filter, 7: Filter cooler.

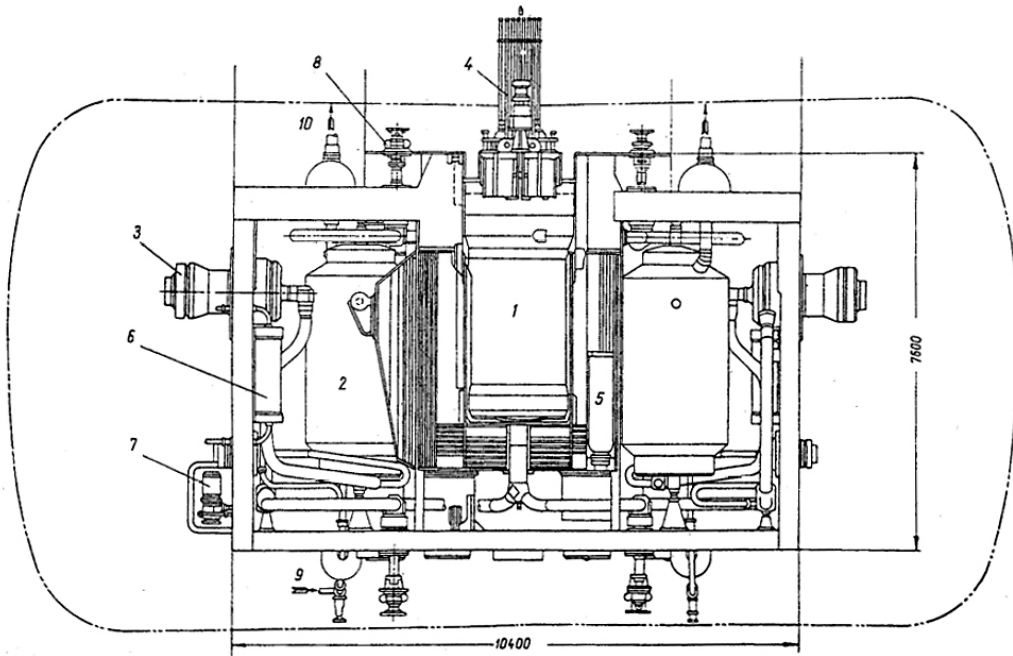

Figure 9. Layout of OK-150 plant. 1: Reactor, 2: Steam generator, 3: Main circulation pumps, 4: Control rod drives mechanism, 5: Filter, 6: Cooler, 7: Emergency cooling pump, 8: Primary circuit pressure relief valve, 9: Feedwater inlet, 10: Steam outlet.

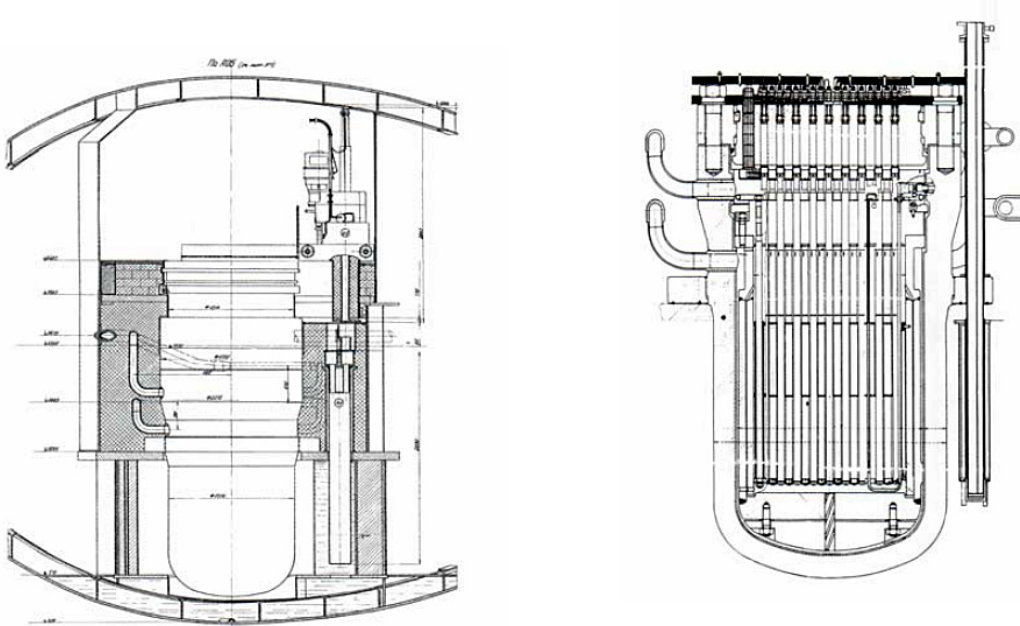
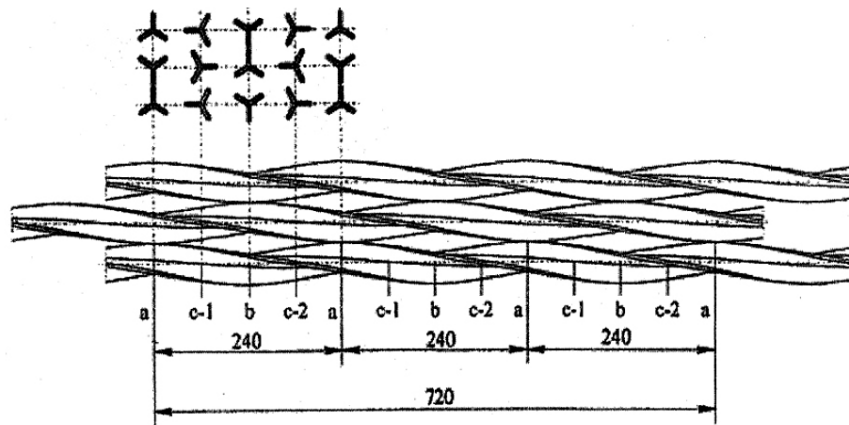

Figure 10. First generation VM-A Russian submarine reactor vessel.



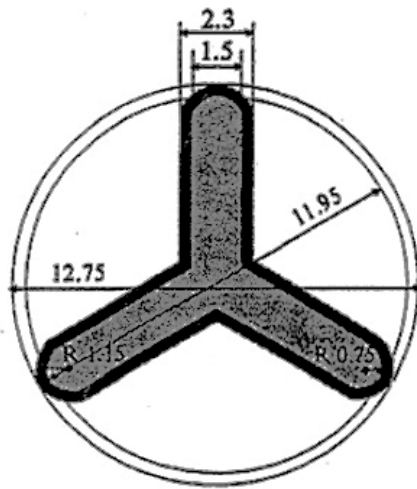

Figure 11. Spiral fuel element configuration.

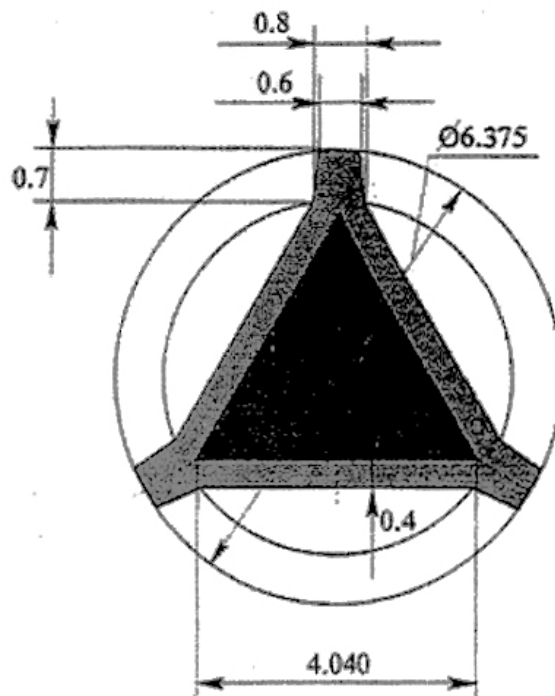

Figure 12. Triangular fuel element configuration.

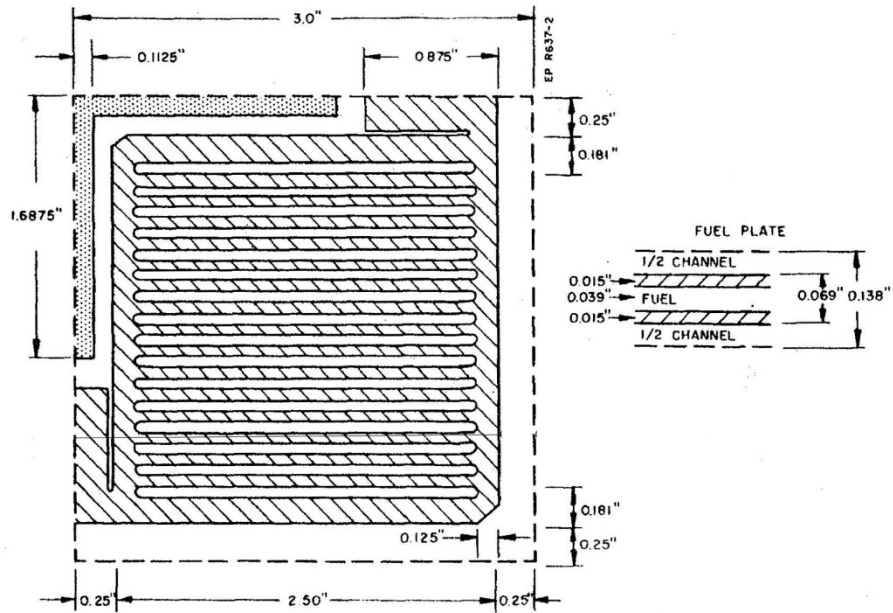

Figure 13. Plate fuel element configuration.

5. XENON FORMATION

The fission process generates a multitude of fission products with different yields. Table 3 shows some of these fission products yields resulting from the fission of three fissile isotopes:

Table 3. Fission products yields from thermal 2200 m/sec neutrons, γ_i [nuclei/fission event].

Isotope	${}_{92}\text{U}^{233}$	${}_{92}\text{U}^{235}$	${}_{94}\text{Pu}^{239}$
${}_{53}\text{I}^{135}$	0.04750	0.06390	0.06040
${}_{54}\text{Xe}^{135}$	0.01070	0.00237	0.01050
${}_{61}\text{Pm}^{149}$	0.00795	0.01071	0.01210

The most prominent of these fission products from the perspective of reactor control is ${}_{54}\text{Xe}^{135}$. It is formed as the result of the decay of ${}_{53}\text{I}^{135}$. It is also formed in fission and by the decay of the Tellurium isotope: ${}_{52}\text{Te}^{135}$. This can be visualized as follows:

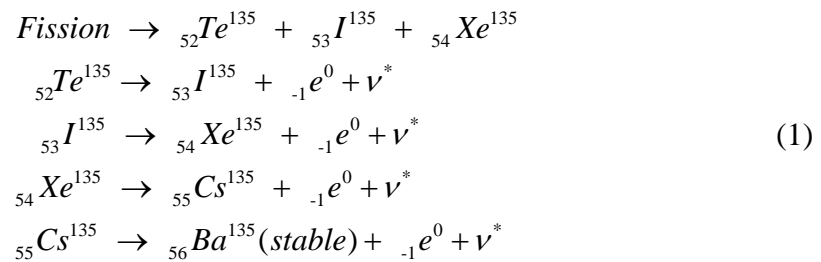

The half lives of the components of this chain are shown in Table 4. The end of the chain is the stable isotope $^{56}\text{Ba}^{135}$.

Because $^{52}\text{Te}^{135}$ decays rapidly with a half life of 11 seconds into $^{53}\text{I}^{135}$, one can assume that all $^{53}\text{I}^{135}$ is produced directly in the fission process.

Denoting $I(t)$ as the atomic density of iodine in [nuclei/cm³], one can write a rate equation for the iodine as:

$$\begin{aligned} \frac{dI(t)}{dt} &= [\text{rate of formation of Iodine from fission}] \\ &\quad - [\text{rate of radioactive transformations of Iodine}] \end{aligned} \quad (2)$$

$$\frac{dI(t)}{dt} = \gamma_I \Sigma_f \psi - \lambda_I I(t)$$

where: γ_I is the fission yield in [nuclei/fission event],

ψ is the thermal neutron flux in [n/(cm².sec)],

Σ_f is the thermal fission cross section in [cm⁻¹],

λ_I is the decay constant in [sec⁻¹], with $\lambda_I = \frac{\ln 2}{T_{1/2}}$, $T_{1/2}$ is the half life.

Table 4. Half lives of isotopes in the xenon chain.

Isotope	Half Life, $T_{1/2}$
$^{52}\text{Te}^{135}$	11 sec
$^{53}\text{I}^{135}$	6.7 hr
$^{54}\text{Xe}^{135}$	9.2 hr
$^{55}\text{Cs}^{135}$	2.3×10^6 yr
$^{56}\text{Ba}^{135}$	Stable

A rate equation can also be written for the xenon in the form:

$$\begin{aligned} \frac{dX(t)}{dt} &= [\text{rate of formation of Xenon from fission}] \\ &\quad + [\text{rate of formation of Xe from the transformation of the Iodine}] \\ &\quad - [\text{rate of radioactive transformations of Xenon}] \\ &\quad - [\text{rate of disappearance of Xenon (X) through neutron absorptions}], \end{aligned} \quad (3)$$

or:

$$\frac{dX(t)}{dt} = \gamma_X \Sigma_f \psi + \lambda_I I(t) - \lambda_X X(t) - \sigma_{aX} \psi X(t)$$

where σ_{aX} is the thermal microscopic absorption cross section for Xenon equal to 2.65×10^6 [b].

The large value of the absorption cross section of Xe, and its delayed generation from Iodine, affect the operation of reactors both under equilibrium and after shutdown conditions.

6. IODINE AND XENON EQUILIBRIUM CONCENTRATIONS

Under equilibrium conditions, the rate of change of the Iodine as well as the xenon concentrations is zero:

$$\frac{dI(t)}{dt} = \frac{dX(t)}{dt} = 0 \quad (4)$$

This leads to an equilibrium concentration for the Iodine as:

$$I_0 = \frac{\gamma_I \Sigma_f \psi}{\lambda_I} \quad (5)$$

The equilibrium concentration for the Xenon will be:

$$X_0 = \frac{\gamma_X \Sigma_f \psi + \lambda_I I_0}{\lambda_X + \sigma_{aX} \psi} \quad (6)$$

Substituting for the equilibrium concentration of the iodine, we can write:

$$X_0 = \frac{(\gamma_X + \gamma_I) \Sigma_f \psi}{\lambda_X + \sigma_{aX} \psi} \quad (7)$$

7. REACTIVITY EQUIVALENT OF XENON POISONING

Ignoring the effects of neutron leakage, since it has a minor effect on fission product poisoning, we can use the infinite medium multiplication factors for a poisoned reactor in the form of the four factor formula:

$$k = \eta \epsilon p f \quad (8)$$

and for an unpoisoned core as:

$$k_0 = \eta \epsilon p f_0 \quad (9)$$

We define the reactivity ρ of the poisoned core as:

$$\rho = \frac{k - k_0}{k} = \frac{\Delta k}{k} = \frac{f - f_0}{f} = 1 - \frac{f_0}{f} \quad (10)$$

In this equation,

$\eta = \frac{\nu \Sigma_f}{\Sigma_{aF}}$, is the regeneration factor,
 ϵ is the fast fission factor,
 p is the resonance escape probability,
 ν is the average neutron yield per fission event,
 Σ_f is the macroscopic fission cross section,
 Σ_{aF} is the macroscopic absorption cross section of the fuel,
 f is the fuel utilization factor.

The fuel utilization factor for the unpoisoned core is given by:

$$f_0 = \frac{\Sigma_{aF}}{\Sigma_{aF} + \Sigma_{aM}} \quad (11)$$

And for the poisoned core it is:

$$f = \frac{\Sigma_{aF}}{\Sigma_{aF} + \Sigma_{aM} + \Sigma_{aP}} \quad (12)$$

where:

Σ_{aM} is the moderator's macroscopic absorption coefficient,
 Σ_{aP} is the poison's macroscopic absorption coefficients.

From the definition of the reactivity in Eqn. 10, and Eqns. 11 and 12 we can readily get:

$$\rho = - \frac{\Sigma_{aP}}{\Sigma_{aF} + \Sigma_{aM}} \quad (13)$$

It is convenient to express the reactivity in an alternate form. For the unpoisoned critical core:

$$1 = k_0 = \eta \epsilon p f_0 = \eta \epsilon p \frac{\Sigma_{aF}}{\Sigma_{aF} + \Sigma_{aM}} \quad (14)$$

From which:

$$\Sigma_{aF} + \Sigma_{aM} = \eta \epsilon p \Sigma_{aF} \quad (15)$$

Substituting this value in the expression of the reactivity, and the expression for the regeneration factor, we get:

$$\rho = - \frac{1}{v\epsilon p} \frac{\Sigma_{aP}}{\Sigma_f} \quad (16)$$

For equilibrium Xenon:

$$\Sigma_{aP} = \sigma_{aX} X_0 = \frac{(\gamma_X + \gamma_I) \Sigma_f \psi \sigma_{aX}}{\lambda_X + \sigma_{aX} \psi} \quad (17)$$

Inserting the last equation for the expression for the reactivity we get:

$$\rho = - \frac{(\gamma_X + \gamma_I) \psi \sigma_{aX}}{(\lambda_X + \sigma_{aX} \psi) v \epsilon p} \quad (18)$$

Dividing numerator and denominator by σ_{aX} we get:

$$\rho = - \frac{(\gamma_X + \gamma_I) \psi}{\left(\frac{\lambda_X}{\sigma_{aX}} + \psi\right) v \epsilon p} \quad (18)'$$

The parameter:

$$\varphi = \frac{\lambda_X}{\sigma_{aX}} = 0.77 \times 10^{13} \quad (20)$$

at 20 degrees C, and has units of the flux [neutrons/(cm².sec)].

The expression for the reactivity is written in terms of ϕ as:

$$\rho = - \frac{(\gamma_X + \gamma_I) \psi}{(\varphi + \psi) v \epsilon p} \quad (18)''$$

For a reactor operating at high flux,

$$\varphi \approx \psi,$$

and we can write:

$$\rho = - \frac{(\gamma_X + \gamma_I)}{v \epsilon p} \quad (21)$$

For a reactor fueled with U^{235} , $\nu = 2.42$, $p = \epsilon = 1$, the value for ρ for equilibrium xenon is:

$$\rho = - \frac{(0.00237 + 0.06390)}{2.42} = - \frac{0.06627}{2.42} = -0.027384$$

or a negative 2.74 percent.

8. REACTOR DEAD TIME

A unique behavior occurs to the xenon after reactor shutdown. Although its production ceases, it continues to build up as a result of the decay of its iodine parent. Therefore the concentration of the xenon increases after shutdown. Since its cross section for neutrons is so high, it absorbs neutrons and prevents the reactor from being restarted for a period of time denoted as the reactor dead time. In a land based reactor, since the xenon eventually decays, after about 24 hours, the reactor can then be restarted. In naval propulsion applications, a naval vessel cannot be left in the water unable to be restarted, and vulnerable to enemy attack by depth charges or torpedoes. For this reason, naval reactor cores are provided with enough reactivity to overcome the xenon negative reactivity after shutdown.

To analyze the behavior, let us rewrite the rate equations for iodine and xenon with ψ equal to 0 after shutdown:

$$\frac{dI(t)}{dt} = - \lambda_I I(t) \quad (22)$$

$$\frac{dX(t)}{dt} = + \lambda_I I(t) - \lambda_X X(t) \quad (23)$$

Using Bateman's solution, the iodine and xenon concentrations become:

$$I(t) = I_0 e^{-\lambda_I t} \quad (24)$$

$$X(t) = X_0 e^{-\lambda_X t} + \frac{\lambda_I}{\lambda_I - \lambda_X} I_0 (e^{-\lambda_X t} - e^{-\lambda_I t}) \quad (25)$$

Substituting for the equilibrium values of X_0 and I_0 we get:

$$X(t) = \frac{(\gamma_X + \gamma_I) \Sigma_f \psi}{\lambda_X + \sigma_{aX} \psi} e^{-\lambda_X t} + \frac{\gamma_I}{\lambda_I - \lambda_X} \Sigma_f \psi (e^{-\lambda_X t} - e^{-\lambda_I t}) \quad (26)$$

The negative reactivity due to xenon poisoning is now a function of time and is given by:

$$\begin{aligned}
\rho(t) &= - \frac{1}{v\epsilon p} \frac{\Sigma_{aP}(t)}{\Sigma_f} \\
&= - \frac{1}{v\epsilon p} \frac{\sigma_{aP} X(t)}{\Sigma_f} \\
&= - \frac{\sigma_{aP}\psi}{v\epsilon p} \left[\frac{\gamma_X + \gamma_I}{\lambda_X + \sigma_{aX}\psi} e^{-\lambda_X t} + \frac{\gamma_I}{\lambda_I - \lambda_X} (e^{-\lambda_X t} - e^{-\lambda_I t}) \right]
\end{aligned}
\tag{27}$$

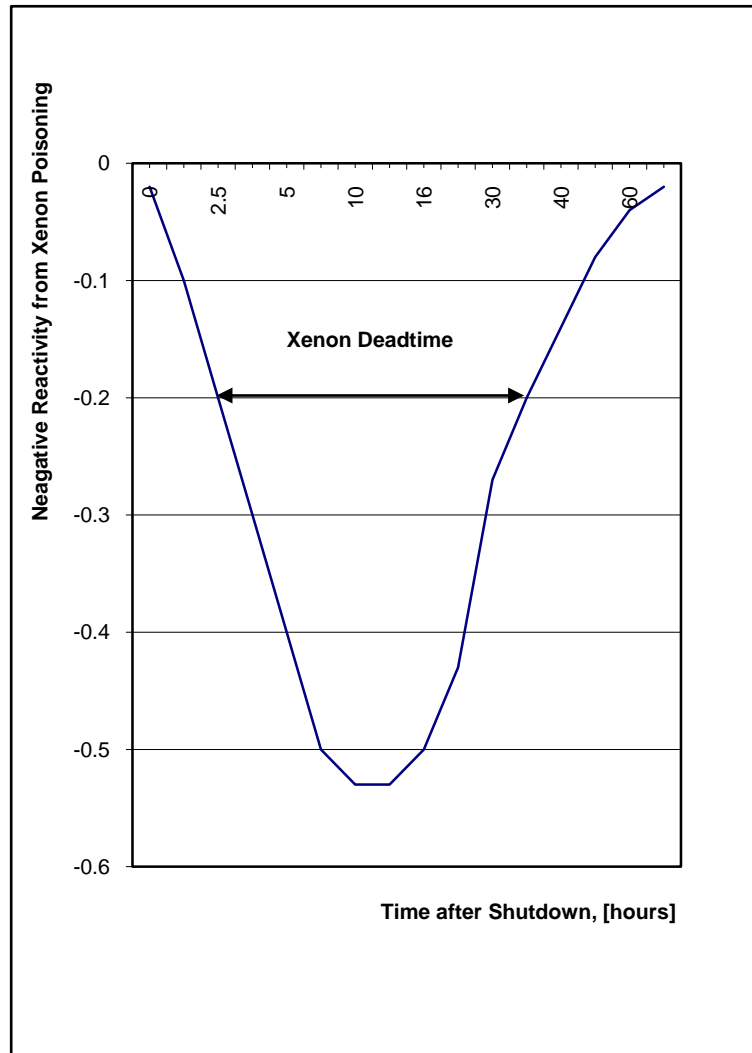

Figure 14. Negative reactivity due to xenon poisoning. Flux = 5×10^{14} [n/(cm².sec)].

Figure 14 shows the negative reactivity resulting from xenon after reactor shutdown. It reaches a minimum value, which occurs at about 10 hours after shutdown. This post shutdown reactivity is important in reactors that have operated at a high flux level. If at any time after shutdown, the positive reactivity available by removing all the control rods is less than the

negative reactivity caused by xenon, the reactor cannot be restarted until the xenon has decayed. In Fig. 14, at an assumed reactivity reserve of 20 percent, during the time interval from 2.5 hours to 35 hours, the reactor cannot be restarted. This period of $35 - 2.5 = 32.5$ hours is designated as the "Reactor Dead Time."

This reactor dead time is of paramount importance in mobile systems that may be prone to accidental scrams. This is more important at the end of core lifetime, when the excess reactivity is limited. For this reason, mobile reactors necessitate the adoption of special design features, providing the needed excess reactivity to override the negative xenon reactivity, such as the use of highly enriched cores.

In land based systems such as the CANDU reactor, booster rods of highly enriched U^{235} are available to override the xenon dead time after shutdown, leading to a higher capacity factor. Power fluctuations induced to follow demand in any power reactor lead to xenon oscillations without any reactor shutdown. The changes of xenon concentrations due to load following are compensated for by adjusting the chemical shim or boron concentration in the coolant, and by control rods adjustments.

9. NUCLEAR NAVIES

INTRODUCTION

The USA nuclear fleet grew rapidly at the height of the east west cold war in the 1980s. About one fourth of the submarine fleet carried intercontinental ballistic missiles. These can be ejected by the use of compressed air while the submarine is totally submerged, with the rocket engine starting once the missile is above the water surface.

In the Falkland Islands War, a single nuclear British submarine paralyzed the entire Argentina Naval fleet. It sunk the cruiser "General Belgrano" and forced the Argentine Navy to not deploy out of port..

During the first and second the Gulf Wars, the USA Navy had unchallenged use of the oceans and protected 85 percent of the war supplies that were transported by ships.

NAVY CARRIER FORCE

The mission of the aircraft carrier force is to provide a credible, sustainable, independent forward presence and a conventional deterrence in peace times. In times of crisis, it operates as the cornerstone of joint and/or allied maritime expeditionary forces. It operates and support air attacks on enemies, protects friendly forces and engages in sustained independent operations in times of war. The vital statistics of the nuclear Nimitz Class aircraft carrier are:

Power Plant:	Two nuclear reactors, four shafts.
Length:	1,092 feet.
Beam:	134 feet.
Displacement:	97,000 tons at full load.
Speed:	30 knots, 34.5 miles per hour.
Aircraft:	85.
Crew:	500 officers, 5,000 enlisted.

NUCLEAR SUBMARINE FORCE

The USA submarine force maintains its position as the world's preeminent submarine force. It incorporates new and innovative technologies allowing it to maintain dominance throughout the naval battle space. It incorporates the multiple capabilities of submarines and develops tactics supporting national objectives through battle space preparation, high seas control, land battle support as well as strategic deterrence. It also fills the role of a stealthy signal and intelligence gathering and a full spectrum of special operations and expeditionary missions. It includes forces of ballistic missile submarines (SSBN), guided missile submarines (SSGN), and attack submarines (SSN). The vital statistics of the Ballistic Missile Trident submarines and the guided missiles submarines are:

Armament, SSBN:	Trident missiles.
Armament, SSGN:	154 Tomahawk missiles, 66 Special operation Forces.
Power Plant:	One nuclear reactor, one shaft.
Length:	560 feet.
Beam:	42 feet.
Displacement:	18,750 tons, submerged.
Speed:	20 knots, 23 miles per hour.
Crew:	15 officers, 140 enlisted.

The statistics for the fast attack Los Angeles class submarines are:

Power Plant:	One nuclear reactor, one shaft.
Length:	360 feet.
Beam:	33 feet.
Displacement:	6,900 tons, submerged.
Speed:	25 knots, 28 miles per hour.
Crew:	12 officers, 121 enlisted.



Figure 15. Christening of a Trident submarine, with two other submarines in different stages of assembly.

RUSSIAN NAVY

The nuclear Russian navy also reached its peak at the same time as the USA navy. The first of the TYPHOON class 25,000 ton strategic ballistic missile submarines was launched in 1980 from the Severodvinsk Shipyard on the White Sea. In the same year the first OSCAR class guided missile was launched. It is capable of firing 24 long range antiship cruise missiles while remaining submerged. Five shipyards produced seven different classes of submarines. Table 5 shows some of the nuclear powered components of the Russian Navy as it existed then.

Table.5. Principal Components of the Russian Nuclear Navy

Designation	Type	Number
Nuclear Powered Submarines		
SSBN	Ballistic Missile Submarines, YANKEE, DELTA, TYPHOON classes.	62
SSBN	Ballistic Missile Submarines, HOTEL class	7
SSGN	Cruise missile Submarines, ECHO I, II, CHARLIE I, II.	50
SSN	Torpedo Attack submarines.	60
Nuclear Powered Cruiser		
CGN	Guided Missile Cruiser, Kirov Class	1

The Delta IV class is nuclear-powered with two VM-4 pressurized water reactors rated at 180 MWth. There are two turbines, type GT3A-365 rated at 27.5MW. The propulsion system drives two shafts with seven-bladed fixed-pitch propellers.

CHINESE NAVY

Five hundred years ago the contender for the dominance of the world's oceans was the Chinese imperial exploration fleet which was at its peak technologically centuries ahead of its competitors. A strategic mistake by its emperor was to neglect its sea access with the result of opening the door to European and then Japanese military intervention and occupation. Being the world's second largest importer of petroleum after the USA, China seeks to protect its energy corridors by sea and free access to Southeast Asia sea lanes beyond the Indochinese Peninsula.

China's naval fleet as of 2008 had 5 nuclear powered fast attack submarines and one ballistic missiles submarine carrying 12-16 nuclear tipped missiles with range of 3,500 km. This is in addition to 30 diesel electric submarines with 20 other submersibles under construction.

The Chinese submarine fleet is expected to exceed the number of USA's Seventh Fleet ships in the Pacific Ocean by 2020 with the historic patience and ambition to pursue a long term strategy of eventually matching and then surpassing the USA's dominance of the sea.

SURFACE VESSELS

Around 1986, the USA's nuclear navy reached the level of 134 nuclear submarines, 9 cruisers, and 4 aircraft carriers. By 2001, the number of nuclear carriers increased to 9, as shown in Table 6 for the Nimitz class of carriers. These aircraft carriers are powered by two nuclear reactors providing propulsion to 4 shafts each. Typically, the power produced is 280,000 Horse Power (HP). Since 1 HP is equal to 745.7 Watts, this corresponds to a power of:

$$280,000 \times 745.7 = 208.8 \text{ MWth.}$$

Smaller reactors are used in the Enterprise class each of a power of about 26 MWth. With four propulsion plants each consisting of 2 reactors for a total of 8 reactors corresponding to 8 steam boilers the total produced power is about $8 \times 26 = 208$ MWth. Hafnium is used in the control rods as a neutron absorber. In the newer Nimitz class, reactor sizes are larger at about 105 MWth, all that is needed are two reactors with a total power of $2 \times 105 = 210$ MWth. Figure 16 shows the Enterprise nuclear aircraft carrier (CVN-65).



Figure 16. The USS nuclear powered aircraft carrier Enterprise CVN-65, 1998. Source: USA Navy.

The crew of the Enterprise is about 5,000 sailors with an average age of 25 years, and its first military operation was in the Cuban missile crisis in 1962. It can top a speed of 30 knots. Its bridge rises six decks above the flight deck. Its flight deck has an area of 4.47 acres.

It is armed with eight air-wing squadrons, Sea Sparrow missiles, and sophisticated intelligence gathering and countermeasures equipment. Its mission is to carry military force within striking range of any point on the planet.

Airplanes land and are catapult launched on two runways. Its air wing has 250 pilots, but thousands of other sailors plan each flight, maintain the planes and move them using massive elevators from the hangar deck to the flight deck. The ship is maneuvered so that the head wind is “sweet” across the deck. Catapults driven with steam from the nuclear reactors fling 30 ton aircraft to full flight in a space shorter than a football field accelerating it from zero to 165 miles/hr in 2 seconds. Carrier pilots have 350 feet of runway to land. They must come at the right angle and position to hook one of the four arresting cables or wires. That will bring the plane to a dead stop. This maneuver has to be completed with engines at full power in case all the four wires are missed, and the plane has to abort the landing.



Figure 17. The Nuclear Powered Guided Missile Cruiser, KIROV.



Figure 18. The Phalanx radar-guided gun, nicknamed as R2-D2 from the Star-Wars movies, is used for close-in ship defense. The radar controlled Gatling gun turret shooting tungsten armor-piercing, explosive, or possibly depleted uranium munitions on the USS Missouri, Pearl Harbor, Hawaii. Photo: M. Ragheb.

The Russian navy's nuclear powered guided missile cruiser KIROV, shown in Fig. 17 from astern, reveals a superstructure massed with radars and electronic sensors, a stern door for Anti Submarine Warfare (ASW) sonar, and a Ka-25 Hormone ASW helicopters deck. The deck is bordered by Gatling guns (Fig. 18) using tungsten or depleted uranium projectiles, short range surface to air missiles and 100 mm dual purpose gun mounts.

Table 6. Principal Components of the USA Nuclear Aircraft Carrier Fleet.

Designation	Name	Class
	Enterprise	Enterprise Class, 8 reactors, 4 shafts, 1961. 93,000 tons full load displacement, 1,123 feet length, 257 ft flight deck width, 33 knots speed, 70 aircraft
CVN68	Nimitz	Nimitz Class, 2 reactors, 4 shafts, 1975.
CVN69	Dwight D. Eisenhower	97,000 tons full load displacement,
CVN70	Carl Vinson	1.073 feet flight deck width,
CVN71	Theodore Roosevelt	252 ft flight deck width,
CVN72	Abraham Lincoln	32 knots speed,
CVN73	George Washington	70 aircraft.
CVN74	John C. Stennis	
CVN75	Harry S. Truman	
CVN76	Ronald Reagan	
CVN77	George W. H. Bush	

This kind of nuclear powered ship has a displacement of 23,000 tons, larger than any surface combatant other than an aircraft carrier built since World War II. It is meant as a multipurpose command ship capable of providing a battle group with enhanced air defense and surface strike capability. Its primary armament is heavy, highly sophisticated surface to air and long range antiship cruise missiles. It carries 20 long range cruise missiles, and includes 12 vertical launch tubes for surface to air missiles.

The Russian navy has conducted research and experimentation on new types of propulsion concepts. It recognized, for instance the advantages of gas turbines for naval propulsion, and dramatically shifted toward it. Gas turbines offer low weight and volume, in addition to operational flexibility, reduced manning levels, and ease of maintenance. Even though gas turbines have been used in surface vessels, it is not clear whether the Brayton gas turbine cycle has been used instead of the Rankine steam cycle on the nuclear powered ships. They have built fast reactors, and studied the use of less reactive lead and lead-bismuth alloys instead of sodium cooling in them. They may also have considered new propulsion concepts such as dissociating gases and magneto hydrodynamic propulsion.

NUCLEAR CRUISE MISSILE SUBMARINES



Figure 19. Russian cruise missile submarine Project 949A Orel.

The nuclear powered ECHO I and II, and the CHARLIE I and II can fire eight antiship weapons cruise missiles while remaining submerged at a range of up to 100 kilometers from the intended target. These cruise missile submarines also carry ASW and antiship torpedoes.

The nuclear cruise missile submarines are meant to operate within range of air bases on land. Both forces can then launch coordinated attacks against an opponent's naval forces. Reconnaissance aircraft can provide target data for submarine launched missiles.

NUCLEAR BALLISTIC MISSILE SUBMARINES

Submarine Launched Ballistic Missiles (SLBMs) on Nuclear Powered Ballistic Missile Submarines (SSBNs) have been the basis of strategic nuclear forces. Russia had more land based Intercontinental Ballistic Missiles (ICBMs) than the SLBM forces.

The Russian ICBM and SLBM deployment programs initially centered on the SS-9 and SS-11 ICBMs and the SS-N-6/YANKEE SLBM/SSBN weapons systems. They later used the Multiple Independently targetable Reentry Vehicles (MIRVs) SS-N-18 on the DELTA class nuclear submarines, and the SS-NX-20 on the nuclear TYPHOON class SSBN submarine.

The Russian SLBM force has reached 62 submarines carrying 950 modern SLBMs with a total of almost 2,000 nuclear warhead reentry vehicles. Russia deployed 30 nuclear SSBNs, and the 20 tube very large TYPHOON SSBN in the 1980s. These submarines were capable to hit targets across the globe from their homeports.



Figure 20. The Nuclear Powered Russian Ballistic Missile Submarine Project 667 DRM.



Figure 21. USA Ballistic missile nuclear submarine SSN Ohio.

The 34 deployed YANKEE class nuclear submarines each carried 16 nuclear tipped missiles. The SS-N-6/YANKEE I weapon system is composed of the liquid propellant SS-N-6 missile in 16 missile tubes launchers on each submarine. One version of the missiles carries a single Reentry Vehicle (RV) and has an operational range of about 2,400 to 3,000 kilometers. Another version carries 2 RVs , and has an operational range of about 3,000 kilometers.

The DELTA I and II classes of submarines displaced 11,000 tons submerged and have an overall length of about 140 meters. These used the SS-N-8 long range, two stages, liquid

propellant on the 12-missile tube DELTA I and the 16 missile tube DELTA II submarines. The SS-N-8 has a range of about 9,000 kilometers and carries one RV. The SS-N-18 was used on the 16 missile tube DELTA III submarines, and has MIRV capability with a booster range of 6,500 to 8,000 kilometers, depending on the payload configuration. The DELTA III nuclear submarines could cover most of the globe from the relative security of their home waters with a range of 7,500 kilometers. Figure 20 shows a DELTA I class SSBN. Figure 21 shows the SSN Ohio ballistic missile submarine.

The TYPHOON class at a 25,000 tons displacement, twice the size of the DELTA III with a length of 170 m and 20 tubes carrying the SS-NX-20 missile each with 12 RVs, has even greater range at 8,300 kms, higher payload, better accuracy and more warheads. Figure 22 shows the known Russian nuclear Ballistic submarines and their missiles systems.

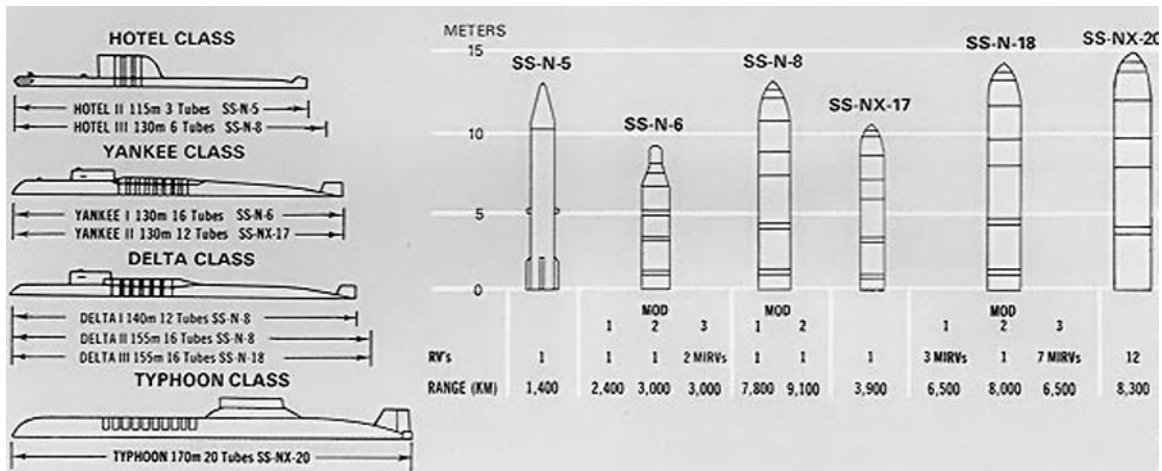

Figure 22. Nuclear Ballistic Missile Submarines and their missiles characteristics.

NUCLEAR ATTACK SUBMARINES

At some time the Russian navy operated about 377 submarines, including 180 nuclear powered ones, compared to 115 in the USA navy.

The Russian navy operated 220 attack submarines, 60 of them were nuclear powered. These included designs of the NOVEMBER, ECHO, VICTOR, and ALFA classes. Figure 23 shows the SSN 23 Jimmy Carter Seawolf class attack submarine. Figure 24 shows a VICTOR-class attack submarine, characterized by deep diving capability and high speed.



Figure 23. SSN 23, Jimmy Carter nuclear attack submarine, 2005.

ALFA CLASS SUBMARINES

The ALFA class submarine was the fastest submarine in service in any navy. It was a deep diving, titanium hull submarine with a submerged speed estimated to be over 40 knots. The titanium hull provided strength for deep diving. It also offered a reduced weight advantage leading to higher power to weight ratios resulting in higher accelerations. The higher speed could also be related to some unique propulsion system. The high speeds of Russian attack submarines were meant to counter the advanced propeller cavitation and pump vibration reduction technologies in the USA designs, providing them with silent and stealth hiding and maneuvering.



Figure 24. The Nuclear Powered Russian VICTOR I class Attack Submarine.

The alpha class of Russian submarines used a lead and bismuth alloy cooled fast reactors. They suffered corrosion on the reactor components and activation through the formation of the highly toxic Po^{210} isotope. Refueling needed a steam supply to keep the liquid metal molten above 257 °F.

Advantages are a high cycle efficiency and that the core can be allowed to cool into a solid mass with the lead providing adequate radiation shielding. This class of submarines has been decommissioned.

10. SEAWOLF CLASS SUBMARINES

The Seawolf class of submarines provided stealth, endurance and agility and are the most heavily armed fast attack submarines in the world.

They provided the USA Navy with undersea weapons platforms that could operate in any scenario against any threat, with mission and growth capabilities that far exceed Los Angeles-class submarines. The robust design of the Seawolf class enabled these submarines to perform a wide spectrum of crucial military assignments, from underneath the Arctic icepack to littoral regions anywhere in the world.

This ship class was capable of entering and remaining in the backyards of potential adversaries undetected, preparing and shaping the battle space, and, if so directed, striking rapidly and decisively.



Figure 25. Rollout of the SSN 23 Jimmy Carter attack submarine.

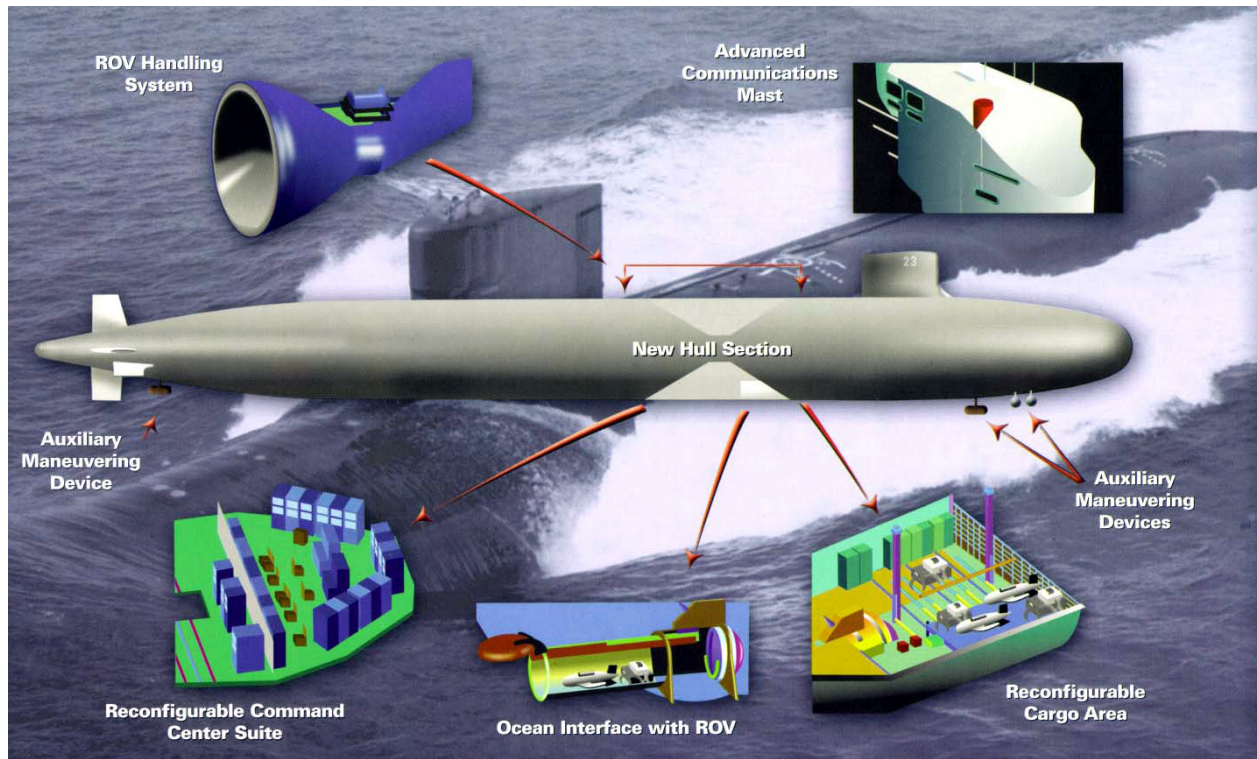

Figure 26. Special features of the SSN 23 Jimmy Carter.



Figure 27. Communications gear on the mast of SSN 23, Jimmy Carter.

Their missions include surveillance, intelligence collection, special warfare, cruise missile strike, mine warfare, and anti-submarine and anti-surface ship warfare

Table 7. Seawolf class of submarines technical specifications.

Builder	General Dynamics, Electric Boat Division.
Power plant	One S6W nuclear reactor, one shaft.
Length	SSN 21 and SSN 22: 353 feet (107.6 meters) SSN 23: 453 feet (138 meters)
Beam	40 feet (12.2 meters)
Submerged Displacement	SSN 21 and SSN 22: 9,138 tons (9,284 metric tons) SSN 23 12,158 tons (12,353 metric tons)
Speed	25+ knots (28+ miles / hour, 46.3+ kilometers / hour)
Crew	140: 14 Officers; 126 Enlisted
Armaments	Tomahawk missiles, MK-48 torpedoes, eight torpedo tubes
Commissioning dates	Seawolf: July 19, 1997 Connecticut: December 11, 1998; Jimmy Carter: February 19, 2005.

11 JIMMY CARTER SSN 23

The \$3.2 billion Jimmy Carter is the third and last of the USA Seawolf class, the huge, deep-diving subs. With a 50-torpedo payload and eight torpedo tubes, the 453-foot, 12,000-ton vessel is the biggest of them all. It was delayed to install a 100 foot hull extension.

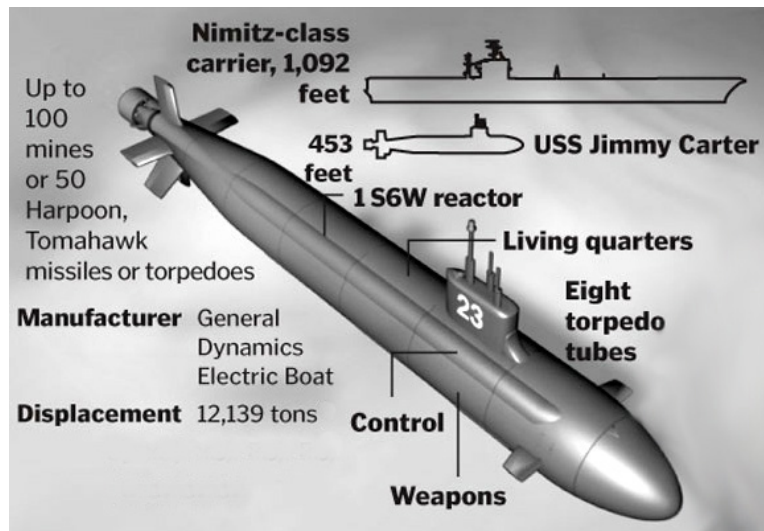

Figure 28. Comparison of size of SSN 23 Jimmy Carter attack submarine to a Nimitz class carrier.

It possesses the ability to tap fiber optic undersea cables and eavesdrop on the communications passing through them. The Carter was extensively modified for communications or signal intelligence through the airwaves gathering from its basic design, given a \$923 million hull extension that allows it to house technicians and gear to perform cable-tapping, and other secret missions. The Carter's hull, at 453 feet, is 100 feet longer than the other two subs in the Seawolf class.

Some of the Carter's special abilities: In the extended hull section, the boat can provide berths for up to 50 special operations troops, such as Navy SEALs. It has an ocean interface that serves as a sort of hangar bay for smaller Remotely Operated Vehicles (ROVs) and drones. It has the usual torpedo tubes and Tomahawk cruise missiles, and it will serve as a platform for researching new technologies useful on submarines.

To listen to fiber-optic transmissions, intelligence operatives must physically place a tap somewhere along the route. If the stations that receive and transmit the communications along the lines are on foreign soil or otherwise inaccessible, tapping the line is the only way to eavesdrop on it.

During the 1970s, a USA submarine placed a tap on an undersea cable along the Soviet Pacific coast, and subs had to return every few months to pick up the tapes. The mission ultimately was betrayed by a spy, and the recording device is now at the KGB museum in Moscow.

Table 8. USS Jimmy Carter technical specifications.

Displacement:	12,140 tons
Power plant	Single S6W reactor.
Length	453 feet
Beam	40 feet
Payload	50 weapons and special operations forces.
Weapons	Tomahawk land attack missiles, Mark 48 advanced capability torpedoes, advanced mobile mines, and unmanned undersea vehicles.
Special Warfare	Dry Deck Shelter, Advanced SEAL Delivery System, Ocean Interface (OI)
Sonars	Spherical active/passive arrays, wide aperture arrays, TB-16 and TB-29 towed arrays, high frequency sail array, high frequency and low frequency bow arrays
Countermeasures	Internal; reloadable, 32 external non-reloadable

12. OHIO CLASS SUBMARINES

The Ohio class submarine is equipped with the Trident strategic ballistic missile from Lockheed Martin Missiles and Space. The Trident was built in two versions, Trident I (C4), which is being phased out, and the larger and longer range Trident II (D5), which entered service in 1990. The first eight submarines, (SSBN 726 to 733 inclusive) were equipped with Trident I and the following ten (SSBN 734 to 743) carry the Trident II. Conversion of the four Trident I submarines remaining after START II (Henry M. Jackson, Alabama, Alaska and Nevada), to

Trident II began in 2000 and is planned to complete in 2008. Lockheed Martin received a contract in January 2002 for the production of 12 Trident II missiles for the four submarines.

The submarine has the capacity for 24 Trident missile tubes in two rows of 12. The dimensions of the Trident II missile are length 1,360 cm x diameter 210 cm and the weight is 59,000 kg. The three-stage solid fuel rocket motor is built by ATK (Alliant Techsystems) Thiokol Propulsion. The US Navy gives the range as “greater than 7,360 km” but this could be up to 12,000 km depending on the payload mix. Missile guidance is provided by an inertial navigation system, supported by stellar navigation. Trident II is capable of carrying up to twelve MIRVs (multiple independent re-entry vehicles), each with a yield of 100 kilotons, although the SALT treaty limits this number to eight per missile. The circle of equal probability (the radius of the circle within which half the strikes will impact) is less than 150 m. The Sperry Univac Mark 98 missile control system controls the 24 missiles.

The Ohio class submarine is fitted with four 533mm torpedo tubes with a Mark 118 digital torpedo fire control system. The torpedoes are the Gould Mark 48 torpedoes. The Mark 48 is a heavy weight torpedo with a warhead of 290kg, which has been operational in the US Navy since 1972. The torpedo can be operated with or without wire guidance and the system has active and/or passive acoustic homing. Range is up to 50 km at a speed of 40 knots. After launch the torpedo carries out target search, acquisition and attack procedures delivering to a depth of 3,000ft.

The Ohio class submarine is equipped with eight launchers for the Mk 2 torpedo decoy. Electronic warfare equipment is the WLR-10 threat warning system and the WLR-8(V) surveillance receiver from GTE of Massachusetts. The WLR-8(V) uses seven YIG tuned and vector tuned super heterodyne receivers to operate from 50MHz up to J-band. An acoustic interception and countermeasures system, AN/WLY-1 from Northrop Grumman, has been developed to provide the submarine with an automatic response against torpedo attack.

The surface search, navigation and fire control radar is BPS 15A I/J band radar. The sonar suite includes: IBM BQQ 6 passive search sonar, Raytheon BQS 13, BQS 15 active and passive high-frequency sonar, BQR 15 passive towed array from Western Electric, and the active BQR 19 navigation sonar from Raytheon. Kollmorgen Type 152 and Type 82 periscopes are fitted.

The main machinery is the pressurized water reactor GE PWR S8G with two turbines providing 60,000 hp and driving a single shaft. The submarine is equipped with a 325 hp Magnatek auxiliary propulsion motor. The propulsion provides a speed in excess of 18 knots surfaced and 25 knots submerged.

13. DEEP SUBMERGENCE NUCLEAR SUBMARINE

The NR-1 is a one of a kind nuclear-powered, deep-submergence submarine, capable of exploring ocean depths to 3,000 feet. Launched on January 25, 1969, and decommissioned on November 21, 2008, it was one of the oldest nuclear-powered submarines in the nuclear USA fleet.

This allows access to most of the world’s continental shelves. Its displacement is just under 400 long tons, which is 1/16th the size of a Los Angeles-class submarine. With her small size its crew to a mere three officers and eight enlisted men. It has exceptional endurance with a nuclear propulsion plant allowing uninterrupted bottom operations for up to 30 days. Its

operational period is limited only by the food and air purification supplies that it carries on board.



Figure 29. The NR-1 deep submergence submarine and its mother ship the SSV Carolyn Chouest.

The NR-1 was conceived in the 1960s as a deep-ocean, bottom-exploring submarine. Her turbo-electric drive train provides power to twin 50-horsepower propulsion motors outside the pressure hull. This results in a mere maximum speed of 3 knots submerged. She is equipped with four ducted thrusters that enable her to maneuver in every direction, even while hovering within inches of the ocean floor. She has a conventional rudder and diving planes mounted on the sail for depth control.

In its nearly 40-year career, the NR-1 was called for countless missions, from searching for wrecked and sunken naval aircraft to finding debris from the space shuttle Challenger after its loss in 1986, to tapping into underwater communication cables.

Its highly advanced sonar, unlike the system on an attack submarine, which is directed at the entire water column, was pointed downward and could detect an “empty soda can buried in the sand a mile away.”

Some unique features of the NR-1 include having wheels for motion on the ocean floor, three viewing ports for visual observation, and 29 exterior lights to support 13 television and still cameras, an object recovery claw, a manipulator arm for various gripping and cutting tools, and a work basket to hold items recovered from the sea. Numerous protuberances around the ship include two retractable bottoming wheels mounted with alcohol filled Goodyear truck tires giving the ship a unique bottom sitting and crawling capability.

The NR-1’s nuclear propulsion plant gives her the ability to operate independently of surface ships, since it provides ample electrical power for all onboard sensors and life-support systems and gives the ship essentially unlimited endurance. Due to her small size and relatively

slow speed on the surface, the NR-1 is towed while submerged to and from remote mission locations by a dedicated support vessel, the SSV Carolyn Chouest (Fig. 29).

14. FUTURE SUBMARINE FORCE: VIRGINIA CLASS

The Virginia class of submarines represents the future nuclear navy force in the USA. The USA Navy plans on developing the Virginia Class into a fully modular, all-electric submarine that will accommodate large modules to provide interfaces for future payloads and sensors. It is a 30 ships class replacing the Los Angeles Class SSNs, possessing the stealth of the Seawolf Class of submarines but at a 30 percent lower total cost. It has mission reconfigurable modules capabilities. It is equipped with Unmanned Undersea Vehicles (UUVs) and improved sensors and communication systems. It is characterized with improved habitability, and is equipped with advanced strike munitions and deployable networked sensors.

The main propulsion units are the ninth generation GE Pressurized Water Reactor S9G, designed to last as long as the submarine, two turbine engines with one shaft and a United Defense pump jet propulsor, providing 29.84 MW. The speed is 25+ knots dived.

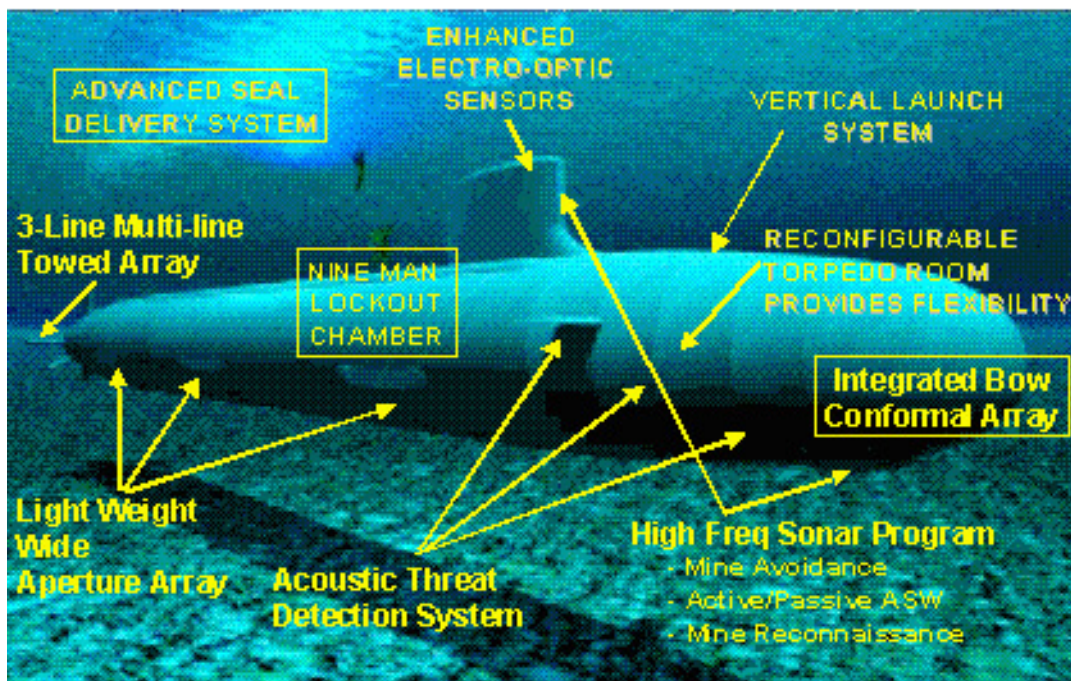

Figure 30. Characteristics of the Virginia class of the nuclear all-electric submarines.

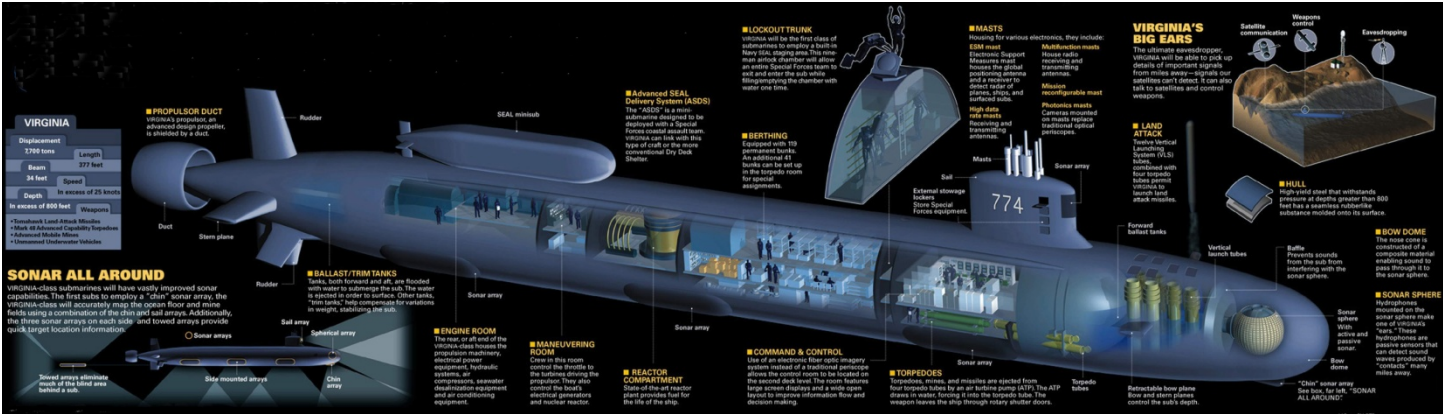

Figure 31. Cutout of Virginia class submarine. Note the innovative jet pump propulsion system at left. Source: General Dynamics.

Its principal features are:

1. An all electrical ship.
2. Enhanced stealth.
3. Modular isolated decks.
4. Open system architecture.
5. Modular masts.
6. Structurally integrated enclosures.
7. Mission reconfigurable torpedo room.
8. Enhanced special warfare capabilities.
9. Enhanced Littoral performance.

The Technical Specifications of the Virginia Class submarine are listed in Table 9.

Table 9. Technical Specifications of the Virginia Class of Submarines.

Power Plant	Single S9G PWR Single shaft with pump jet propulsion One secondary propulsion submerged motor
Displacement	7,800 tons, submerged
Length	277 ft
Draft	32 ft
Beam	34 ft
Speed	25+ knots, submerged
Horizontal tubes	Four 21 inches torpedo tubes
Vertical tubes	12 Vertical Launch System Tubes
Weapon systems	39, including: Vertical Launch System Tomahawk Cruise Missiles Mk 48 ADCAP Heavy weight torpedoes Advanced Mobile Mines Unmanned Undersea Vehicles

Special warfare	Dry Deck Shelter
Sonars	Spherical active/passive arrays Light Weight Wide Aperture Arrays TB-16, TB-29 and future towed arrays High frequency chin and sail arrays
Counter measures	1 internal launcher 14 external launchers
Crew	113 officers and men

It is designed for mine avoidance, special operations forces delivery and recovery. It uses non acoustic sensors, advanced tactical communications and non acoustic stealth. In the future it will be equipped with conformal sonar arrays. Conformal sonar arrays seek to provide an optimally sensor coated submarine with improved stealth at a lower total ownership cost. New technology called Conformal Acoustic Velocity Sonar (CAVES) will replace the existing Wide Aperture Array technology and will be implemented starting in early units of the Virginia class.

High Frequency Sonar will play more important role in future submarine missions as operations in the littorals require detailed information about the undersea environment to support missions requiring high quality bathymetry, precision navigation, mine detection or ice avoidance. Advanced High Frequency Sonar systems are under development and testing that will provide submarines unparalleled information about the undersea environment. This technology will be expanded to allow conformal sonar arrays on other parts of the ship that will create new opportunities for use of bow and sail structure volumes while improving sonar sensor performance.

15. S9G NINTH GENERATION REACTOR DESIGN

The S9G Next Generation Reactor and associated components will have increased energy density. The core that is under development for the New Attack Submarine is expected to last the life of the ship. The design goals include eliminating the need for a refueling, will reduce life cycle costs, cut down the radiation exposure of shipyard workers, and lessen the amount of radioactive waste generated. This is possible because of many developments such as use of advanced computers to perform three-dimensional nuclear, thermal, and structural calculations; further exploitation of the modified fuel process; and better understanding of various reactor technologies which permits more highly optimized designs. Performance improvements are gained through advances in such areas as thermal hydraulics and structural mechanics, and by optimizing reactor-to-systems interfaces.

The new reactor which will have increased energy density, and new plant components, such as a new concept steam generator, with improved corrosion resistance and reduced life-cycle costs. The new steam generators will also allow greater plant design flexibility and decreased construction costs due to smaller size, spatial orientation, and improved heat transfer efficiency which reduces coolant flow requirements. A new concept steam generator would alleviate the corrosion concerns encountered in existing designs of steam generators, while reducing component size and weight and providing greater flexibility in overall arrangement.

16. NUCLEAR ICE BREAKERS

INTRODUCTION

Nuclear-powered icebreakers were constructed by Russia for the purpose of increasing the shipping along the northern coast of Siberia, in ocean waters covered by ice for long periods of time and river shipping lanes. The nuclear powered icebreakers have far more power than their diesel powered counterparts, and for extended time periods. During the winter, the ice along the northern Russian sea way varies in thickness from 1.2 - 2 meters. The ice in the central parts of the Polar Sea, is 2.5 meters thick on average. Nuclear-powered icebreakers can break this ice at speeds up to 10 knots. In ice free waters the maximum speed of the nuclear powered icebreakers is 21 knots.

In 1988 the NS Sevmorpu was commissioned in Russia to serve the northern Siberian ports. It is a 61,900 metric tonnes, 260 m long and is powered by the KLT-40 reactor design, delivering 32.5 propeller MW from the 135 MWth reactor.

APPLICATIONS

Russia operated at some time up to eight nuclear powered civilian vessels divided into seven icebreakers and one nuclear-powered container ship. These made up the world's largest civilian fleet of nuclear-powered ships. The vessels were operated by Murmansk Shipping Company (MSC), but were owned by the Russian state. The servicing base Atomflot is situated near Murmansk, 2 km north of the Rosta district.



Figure 32. Nuclear icebreaker Arktika.

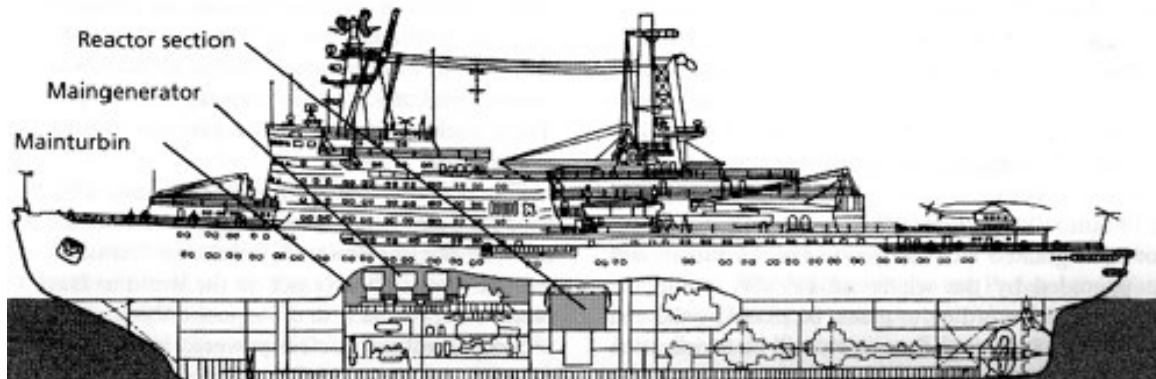

Figure 33. Schematic of Russian Nuclear icebreaker Arktika showing emplacement of nuclear reactor at its center.

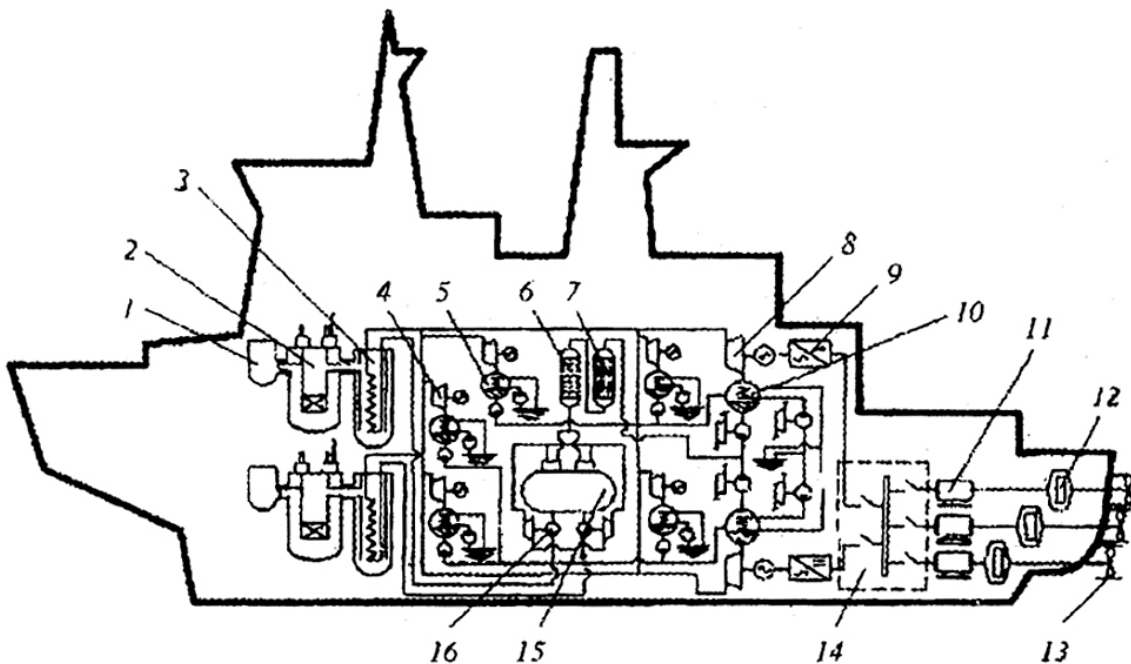

Figure 34. Nuclear reactor components of the icebreaker Arktika. 1: Circulation pumps, 2: Reactor vessel, 3: Steam generator, 4: Auxiliary turbo generator, 5: Condenser, 6: Ion exchange resins filter, 7: Mechanical filter, 8: Main turbo electrical generator, 9: Converter, 10: Main condenser, 11: Electrical propeller motor, 12: Intermediate bearing, 13: Screw propeller, 14: Circuit breaker for propeller motor, 15: Deaerator, 16: Turbo feed pump.

Icebreakers facilitated ores transportation from Norilsk in Siberia to the nickel foundries on the Kola Peninsula, a journey of about 3,000 kms.

Since 1989 the nuclear icebreakers have been used to transport wealthy Western tourists to visit the North Pole. A three week long trip costs \$ 25,000.

The icebreaker Lenin, launched in 1957 was the world's first civilian vessel to be propelled by nuclear power. It was commissioned in 1959 and retired from service in 1989. Eight other civilian nuclear-powered vessels were built: five of the Arktika class, two river icebreakers and one container ship. The nuclear icebreaker Yamal, commissioned in 1993, is the most recent nuclear-powered vessel added to the fleet as shown in Table 10.

Table 10. Russian civilian ice breakers operated by the Murmansk Shipping Company.

Ice Breaker	Launch / Decommissioning Dates	Class or Type
Lenin	1959 / 1989	Icebreaker
Arktika	1975	Arktika
Sibir	1977	Arktika
Rossiia	1985	Arktika
Sevmorput	1988	Container ship
Taimyr	1989	River icebreaker
Sovyetskiy	1990	Arktika
Soyuz	-	Soyuz
Vaigach	1990	River icebreaker
Jamal	1993	Arctika

REACTOR TYPES FOR ICEBREAKERS

The nuclear icebreakers are powered by pressurized water reactors of the KLT-40 type. The reactor contains fuel enriched to 30-40 percent in U²³⁵. By comparison, nuclear power plants use fuel enriched to only 3-5 percent. Weapons grade uranium is enriched to over 90 percent. American submarine reactors are reported to use up to 97.3 percent enriched U²³⁵. The irradiated fuel in test reactors contains about 32 percent of the original U²³⁵, implying a discharge enrichment of $97.3 \times 0.32 = 31.13$ percent enrichment.

Under normal operating conditions, the nuclear icebreakers are only refueled every three to four years. These refueling operations are carried out at the Atomflot service base. Replacement of fuel assemblies takes approximately 1 1/2 months.

For each of the reactor cores in the nuclear icebreakers, there are four steam generators that supply the turbines with steam. The third cooling circuit contains sea water that condenses and cools down the steam after it has run through the turbines. The icebreaker reactors' cooling system is especially designed for low temperature Arctic sea water.

17. DECOMMISSIONING AND DEFUELING

Navy nuclear ships are decommissioned and defueled at the end of their useful lifetime, when the cost of continued operation is not justified by their military capability, or when the ship is no longer needed. The Navy faces the necessity of downsizing the fleet to an extent that was not envisioned in the 1980's before the end of the Cold War. Most of the nuclear-powered cruisers will be removed from service, and some Los Angeles Class submarines are scheduled

for removal from service. Eventually, the Navy will also need to decommission Ohio Class submarines.

Nuclear ships are defueled during inactivation and prior to transfer of the crew. The defueling process removes the nuclear fuel from the reactor pressure vessel and consequently removes most of the radioactivity from the reactor plant. Defueling is an operation routinely accomplished using established processes at shipyards used to perform reactor servicing work.

After a nuclear-powered ship no longer has sufficient military value to justify continuing to maintain the ship or the ship is no longer needed, the ship can be: (1) placed in protective storage for an extended period followed by permanent disposal or recycling; or (2) prepared for permanent disposal or recycling. The preferred alternative is land burial of the entire defueled reactor compartment at the Department of Energy Low Level Waste Burial Grounds at Hanford, Washington.

A ship can be placed in floating protective storage for an indefinite period. Nuclear-powered ships can also be placed into storage for a long time without risk to the environment. The ship would be maintained in floating storage. About every 15 years each ship would have to be taken out of the water for an inspection and repainting of the hull to assure continued safe waterborne storage. However, this protective storage does not provide a permanent solution for disposal of the reactor compartments from these nuclear-powered ships. Thus, this alternative does not provide permanent disposal.

Unlike the low-level radioactive material in defueled reactor plants, the Nuclear Waste Poficy Act of 1982, as amended, requires disposal of spent fuel in a deep geological repository.

The Hanford Site is used for disposal of radioactive waste from DOE operations. The pre Los Angeles Class submarine reactor compartments are placed at the Hanford Site Low Level Burial Grounds for disposal, at the 218-E-12B burial ground in the 200 East area. The land required for the burial of approximately 100 reactor compartments from the cruisers, Los Angeles, and Ohio Class submarines would be approximately 4 hectares or 10 acres..

An estimated cost for land burial of the reactor compartments is \$10.2 million for each Los Angeles Class submarine reactor compartment, \$12.8 million for each Ohio Class submarine reactor compartment, and \$40 million for each cruiser reactor compartment.

The estimated total Shipyard occupational radiation exposure to prepare the reactor compartment disposal packages is 13 rem generating a risk of approximately 0.005 additional latent cancer fatalities for each Los Angeles Class submarine package, 14 rem or a risk of approximately 0.006 additional latent cancer fatalities for each Ohio Class submarine package and 25 rem or a risk of approximately 0.01 additional latent cancer fatalities for each cruiser package.

18. ACCIDENTS OCCURRENCES

INTRODUCTION

Naval vessels are built in a highly sturdy fashion to withstand combat conditions and their crews are highly professional and well trained. Accordingly, accidents occurrences have been rare, but reporting about them is sketchy even though there is a need to learn from their experience to avoid their future occurrence. The Naval Reactors office at the USA Department

of Energy (USDOE) defines an “accident” as an event in which a person is exposed to radiation above the prescribed safe federal limits.

The most notable accidents for the USA Navy were the loss of the Thresher and the Scorpion nuclear submarines. The discovery of the Titanic wreck was a spinoff of the technology developed for investigating these accidents at great water depths.

USS THRESHER, SSN-593, ACCIDENT, 1963

The USS Thresher of the Permit class attack submarine was powered with a Westinghouse S5W nuclear reactor, with a displacement of 4,300 metric tonnes, a length of 85 meters, and a maximum speed of 30 knots. The crew of 129 comprised 12 officers, 96 enlisted men, 4 shipyard officers, and 17 civilian specialists.

On April 9, 1963 the USS Thresher, accompanied by the submarine rescue ship USS Skylark (ASR-20), sailed out of Portsmouth, New Hampshire for a planned 2 days of deep diving test trials.

On the morning of April 10, 1963 at 8:53 am, the Thresher dived contacting the Skylark at every 49 meters of its dive. As it neared its test depth, around 9:10 am it did not respond to the Skylark’s communications. The Skylark’s queries were answered by the ominous sound of compartments collapsing. Surface observers realized that the Thresher was lost when their sonar operations heard the sound of compressed air for 20-30 seconds. The Skylark reported to headquarters that it lost contact with the Thresher at 9:17 am. The accident sequence lasted about 7 minutes.

The possible causes of the accident were surmised to be:

1. Water leaking from damaged pipes inside the pressure hull,
2. The pressure hull disintegrating when the submarine approached its maximum diving depth of 3,000 feet or $(304 \times 3,000) / 1,000 = 912$ meters. (1,000 feet = 304 meters),
3. The submarine dived below its maximum diving depth due to crew error in an area with a depth of 8,400 feet or $(304 \times 8,400) / 1,000 = 2,560$ meters.

An extensive underwater search using the deep diving bathyscaphe Trieste located the Thresher on the sea floor broken into 6 major sections. The debris field covered an area of 134,000 m² or 160,000 square yards. A possible human error could be related to the initial testing being undertaken at a relatively high depth location.

USS SCORPION, SSN-589, ACCIDENT, 1968

The USS Scorpion was a 3,500 ton Skipjack class nuclear-powered attack submarine built at Groton, Connecticut. It was commissioned in July 1960 and assigned to the Atlantic Fleet. The Scorpion was assigned to a Mediterranean cruise in February 1968. The following May, while homeward bound from that tour, she was lost with her entire crew some 400 miles southwest of the Azores Island.

The Scorpion was designed primarily for anti submarine warfare against the USSR nuclear submarine fleet and it carried special teams of Russian-speaking linguists to eavesdrop on transmissions by the USSR Navy and other military units.

On May 17, 1968, led by Cmdr. Francis Slattery, the Scorpion had just completed a three month deployment to the Mediterranean Sea with the USA 6th Fleet and was on its way home to

Norfolk, Virginia. Vice Adm. Arnold Schade, commander of the Atlantic Submarine Force in Norfolk, had a new mission for the Scorpion. The submarine was ordered to head at high speed toward the Canary Islands, 1,500 miles away off the east coast of Africa, to gather intelligence on a group of USSR ships lurking in the eastern Atlantic southwest of the Azores island chain. The Soviet ships there included an Echo-II class nuclear submarine designed to attack aircraft carriers but also armed with anti-submarine torpedoes.

In late October 1968, the remains of the Scorpion were found on the sea floor over 10,000 feet below the surface by a towed deep-submergence vehicle deployed from the USNS submersible craft Mizar (T-AGOR-11).

Photographs showed that her hull had suffered fatal damage while she was running submerged and that even more severe damage occurred as she sank. The cause of the initial damage continues to generate controversy decades later and may have been a casualty of the Cold War.

On May 17, 1968, the USS Scorpion had received a top secret message shortly before midnight to change course and head for the Canary Islands, where a collection of USSR ships had caught the Navy's attention. Thirty three minutes later, the Scorpion surfaced at the USA submarine base at Rota, Spain, to transfer two crewmen ashore via a Navy tug. The men had emergency leave orders, one for a family matter and the other for medical reasons. The submarine sank five days later on May 22, 1968.

More than five months later, the Scorpion's wreckage was found on the ocean floor, two miles deep in the Atlantic. All 99 men aboard were lost.

The USA Navy's initial position was that the Scorpion sank because of a malfunction while returning to its home port of Norfolk, Virginia. While the precise cause of the loss remained undetermined, there was no information to support the theory that the submarine's loss resulted from hostile action of any involvement by a USSR ship or submarine.

Another opinion suggested that the Scorpion was at the center of a web of intelligence gathering and surveillance and a possible Cold War military activity that resulted in an alleged agreement by both the USA and the former USSR to cover up the full accounting of what happened.

A scenario dramatically different from the official Navy version was reported alleging that the Scorpion was not on a routine crossing of the Atlantic, but had been diverted to a top-secret mission to spy on a group of Soviet ships, including a nuclear submarine. Although the Navy's official explanation was of a mechanical malfunction, this countered an earlier conclusion by a panel of senior Navy officials that the Scorpion was sunk by a torpedo. The panel concluded it was one of the Scorpion's own torpedoes that went errant. Experts still disagree about whether it could have been a USSR torpedo.



Figure 35. Launch of the USS Scorpion.

An allegation was that even though the Scorpion believed it was operating in secret, Navy warrant officer John Walker, the Navy's most notorious spy, had communicated to the USSR the codes they needed to track the USA submarine in the hours before it sank. The USSR had the ability to monitor all electronic transmissions to the Scorpion, including the encrypted orders sending it on its intelligence gathering mission.

Russian Navy admirals said that senior Navy officials in both the USA and the USSR agreed to never disclose details of the Scorpion incident and the loss of a Soviet missile sub in the Pacific two months earlier in 1968.

Two months before the Scorpion sank, a Soviet missile sub known as the K-129 sank thousands of miles away, in the Pacific Ocean, also under mysterious conditions. There have been assertions by Russian submarine veterans over the years that the K-129 sank after an alleged collision with a USA attack submarine that allegedly had been shadowing it. USA military officials insisted the Golf-class submarine went down with its 98 man crew after an internal explosion, based on analysis of the sounds of the sinking captured on Navy hydrophones.

Retired Capt. Peter Hutchhausen was the USA Naval attaché in Moscow in the late 1980s, two decades after both incidents. He reported that he had several terse but pointed conversations with counterpart Soviet admirals about the two sinkings of the Scorpion and the K-K-129. One encounter was in June 1987 with Admiral Pitr Navoytsev, first deputy chief for operations of the Soviet Navy. When he asked Navoytsev about the Scorpion, Capt. Hutchhausen recalls his response: "Captain, you are very young and inexperienced, but you will learn that there are some things both sides have agreed not to address, and one is that event and our K-129 loss, for similar reasons." In another discussion in October 1989, Capt. Huchthausen said Vice Adm. B.M. Kamarov told him that a secret agreement had been reached between the USA and USSR in which both sides agreed not to press the other government on the loss of their submarines in 1968. The motivation, Capt. Huchthausen said, was to preserve the thaw in superpower relations.

A senior admiral in the Pentagon at the time of the Scorpion sinking said that USA intelligence agencies feared the submarine was headed into possible danger, based on intercepted Soviet naval communications in the Atlantic Ocean.

There was some communications analysis that the Scorpion had been detected by the group she had been shadowing and conceivably they had trailed her. There were some speculations that not only did they track her but attacked her as a tit-for-tat for the K-129 sinking. A further suggestion was that it was lured into a trap and ambushed. However, the intelligence of USSR hostility has never been confirmed.

The Navy mounted a secret search for the submarine within 24 hours of its sinking. The search was highly classified. The rest of the Navy, and even a Navy Court of Inquiry that investigated the sinking later in 1968, were never told about it.

The Court of Inquiry that probed the loss of the Scorpion in the summer and fall of 1968 described the Soviet presence as an undefined "hydro-acoustic" research operation involving two research vessels and a submarine rescue ship among others, implying the Soviets were merely engaging in research on oceanographic studies of sound effects in the ocean rather than a military mission. Pentagon officials had been concerned that the USSR was developing a way to support warships and submarines at sea without requiring access to foreign seaports for supplies.

What is known is that 15 hours after sending its final message, the Scorpion exploded at 6:44 pm on May 22, 1968, and sank in more than 2 miles of water depth about 400 miles southwest of the Azores. The Navy said it could not identify the "certain cause" of the loss of the Scorpion.

In late 1993, the Navy declassified most of the Court of Inquiry's 1968 conclusions that it had earlier classified. Headed by retired Vice Adm. Bernard Austin, the court had concluded that the best evidence pointed to an errant Scorpion own torpedo that circled around and exploded against the hull of the sub. The court's conclusion stemmed in part from records showing that the Scorpion has had a similar occurrence in 1967 with an unarmed training torpedo that suddenly started up and had to be jettisoned.

In its final 1,354-page report, the Court of Inquiry rejected two alternative theories for the loss: the contention by that an unspecified mechanical problem had set off a chain of events leading to massive flooding inside the submarine, and a scenario that an explosion inside the submarine touched off the sinking. The court also concluded that it was "improbable" the Scorpion sank as the result of "enemy action."

In 1970, a different Navy panel completed another classified report that disavowed the Court of Inquiry's conclusion. Instead of an accidental torpedo strike, the new group suggested a mechanical failure caused an irreparable leak that flooded the submarine. That report said the bulk of the evidence suggested an internal explosion in the submarine's massive electrical battery caused the sub to flood and sink.

Two senior Navy officials involved in the initial Scorpion probe in the summer of 1968 suggested that the Court of Inquiry conclusion of an accidental torpedo strike remains the most realistic scenario because of the key acoustic recordings of the sinking. Underwater recordings retrieved from three locations in the Atlantic, the Canary Islands and two sites near Newfoundland, captured a single sharp noise followed by 91 seconds of silence, then a rapid series of sounds corresponding to the overall collapse of the submarine's various compartments and tanks. There was no way one can have the hull implode and then have 91 seconds of silence while the rest of the hull decides to try and hang itself together.

Retired Adm. Bernard Clarey, who in 1968 was the Navy's senior submariner, dismissed the battery explosion theory asserting that such a mishap could not have generated the blast and acoustic energy captured on the hydrophone recordings.

While several retired submariners over the years have speculated the Scorpion was ambushed and sunk by a Soviet submarine, no conclusive proof of a deliberate attack has appeared. The Navy concluded in 1968 probe there was “no evidence of any Soviet preparations for hostilities or a crisis situation as would be expected in the event of a premeditated attack on Scorpion.”

The Court of Inquiry report was silent on whether an inadvertent clash may have resulted in the sinking. A Navy spokesperson said the Court of Inquiry had found the Scorpion was 200 miles away from the Soviet ships at the time it sank.

JOHN S. STENNIS, CVN-74 LOCA ACCIDENT, 1999

On November 30, 1999 the nuclear aircraft carrier CVN-74 John S. Stennis ran aground in a shallow area adjacent to its turning basin as it attempted to maneuver off the California coast near Naval Air Station North Island, San Diego. This resulted into clogging by silt of the inlet coolant pipes to its two reactors and causing what would amount to a loss of cooling accident for a period of 45 minutes. One reactor was shut down by the automatic control system and the second was left running at low power to provide energy to the vessel and eventually taken offline by the operators until an alternate cooling supply was provided. The vessel was possibly lightened of its water and fuel supplies and towed by tugboats to its pier at high tide. The cleanup cost about \$2 million.

SAN FRANCISCO UNDERWATER COLLISION, 2005

A January 8, 2005 incident occurred to the USS San Francisco nuclear submarine which sustained structural damage that shredded its bow and destroyed a water filled fiberglass sonar dome and forward ballast tanks when it hit in a glancing blow an underwater mountain 525 feet underwater that was not on its navigational charts.

Satellites images showed the presence of the mountain but were not incorporated into the navigational charts. The submarine was travelling at 30 knots when the accident occurred. The accident caused the death of one sailor and injured 60 others. The submarine crew took emergency measures to blast to the surface and keep the vessel afloat. An air blower was run for 30 hours to limit water seepage from holes in the forward ballast tanks keeping the vessel from sinking too low to maneuver.

The hull of a submarine is composed of two parts made of high strength steel such as HY-80 for the LA class submarines. The inner hull, that is much thicker and stronger than the outer hull and encloses the crew's living quarters and working spaces, held firm. The high yield steel can withstand pressure at depths greater than 800 feet and has a seamless rubberlike substance molded onto its surface. The ballast tanks are positioned between the two hulls. Two doors that shutter the torpedo hatches held tight and did not flood. The nuclear reactor was unaffected and powered the vessel back 360 miles northeast to its port at Guam.

The nose cone that is constructed of a composite material enabling sound to pass through it to a sonar sphere with active and passive sonar, was shattered. The sonar sphere is covered

with hydrophones mounted on its surface and is isolated from sounds generated by the submarine by a baffle. In addition to the spherical array, the Virginia class of submarines is equipped with a chin, sail, three side mounted arrays on each side and a towed array that eliminates much of the blind area behind the submarine.

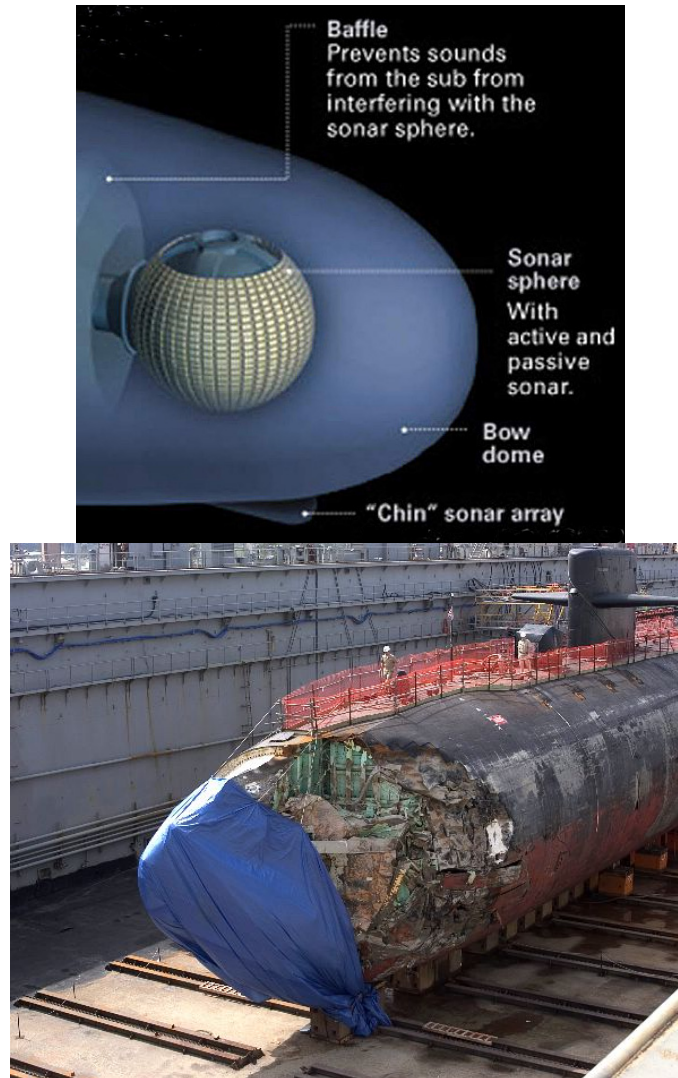

Figure 36. USS San Francisco accident, January 8, 2005. Damage from the glancing collision to the bow dome and to the double hull structure can be observed. A bulge over the hull can also be noticed.

NERPA, AKULA CLASS FIRE, 2008

An accident occurred on the Nerpa, an Akula Class Russian nuclear attack submarine on sea trials in the Pacific Ocean that was planned to be leased to the Indian Navy on November 8, 2008. The event claimed twenty deaths and 21 injuries to people who were not able to use the portable breathing gear issued to Russian submarine crews. The deaths were caused by the

inhalation of the freon toxic gas used as a fire suppressant in the vessel's fire extinguishing system that went off unexpectedly. Most of the injured were civilian workers from the Amur Ship Building Enterprise shipyard that built the submarine. Seventeen victims were civilian employees and three were sailors. Reportedly, 208 people or about 3 times the size of the usual crew were on board the submarine during its testing.



Figure 37. Akula Class Russian nuclear submarine with its tail sonar gear.

USS HOUSTON COOLANT LEAK, 2008

In 2008, it was reported that the nuclear submarine USS Houston had a coolant leak. This was the first coolant leakage of its kind, and because of its small magnitude; it went undetected for two years.

HMS VANGUARD, LE TRIOMPHANT COLLISION, 2009

While travelling at low speed, the ballistic missile submarine HMS Vanguard sustained dents and scratches on its hull when it collided in the Atlantic with the French ballistic missile submarine Le Triomphant in early 2009. The latter incurred damage to its sonar dome located under its bow. The sophisticated sonar equipment failed to detect the presence of the other submarine directly ahead of it.



Figure 38. British nuclear submarine HMS Vanguard to the left, and French Le Triomphant (The Triumphant) to the right collided in the Atlantic in 2009.

The UK possesses four ballistic missile submarines, as do the French, the USA has 14, the Russians 15, and the Chinese three. The 173 meter or 567 feet long Dimitry Donskoy is the world's largest strategic submarine with twice the displacement of the Kursk, which sank in the Barents Sea with 118 sailors in 2000. The hull of the Vanguard is as tall as a four story building and roughly 150 meters or 492 feet in length, and carries 16 ballistic missiles armed with nuclear warheads with a combined power more than about 6 Mt of TNT equivalent.

The methods used to detect submarines do not function reliably except for the passive and active sonars. Special magnetic detectors have been developed to detect the imprints a large steel vessel makes in the Earth's magnetic field, but many external factors can interfere with the devices. Infrared receivers can detect the heat wake generated by a nuclear reactor, but they also mistakenly identify the water being churned up behind a freighter as a submarine. Laser scanning beams cannot penetrate far enough beneath the ocean surface. Bioluminescence detectors detect the light emitted by microbes agitated by a submarine's propellers, but the same microbes also emit light for other reasons. The radioactive wake from neutron activation of the sodium in sea water salt is hard to detect.

Active sonar transmits “ping” noises into the water like whales, and the resulting echo enables the sonar device to compute the location and size of a submarine. However, sound travels far underwater, and a submarine that transmits sound will be revealing its location to a potential adversary. That is why strategic nuclear submarines use passive sonar which a system of highly sensitive hydrophones that uses computers to interpret underwater sounds. A problem is that submarines are extremely quiet; thanks to the use of special propellers and sound insulated engines, and their commanders usually driving them at no more than a walking pace making “less noise than a crab.”

In addition, the ocean is a structured labyrinth for submarine commanders. Layers of water with different salinity levels mimic horizontal ramps and the solid ocean floor, because the layers between them reflect and refract sound waves. Warm currents build vertical walls in the same way. This creates safe spots in the middle of the ocean into which strategic submarine

commanders like to lurk and embed their vessels in, as well as to follow hidden paths that tend to be used by all submarines.

The UK and the USA coordinate the positions of their submarines with France expected to join the NATO military command structure. That leaves Russia and China out.

HARTFORD AND NEW ORLEANS ACCIDENT, 2009

In the morning of March 20, 2009, the 2,899 ton nuclear submarine USS Hartford as part of the USA 5th fleet, was transiting into the Persian Gulf through the Hormuz Straits. It was accompanying an amphibious surface ship, the USS New Orleans, LPD-18, which was making her first extended deployment. The Hartford was submerged but near the surface at the time of the collision.

The two ships collided, and the submarine Hartford rolled 85 degrees to starboard. The impact and rolling caused injuries to 15 Sailors onboard. The bow planes and sail of the submerged Hartford ripped into the hull of the New Orleans.

The collision punched a 16-by-18 foot hole in the fuel tanks of the New Orleans. Two interior ballast tanks were also damaged. The New Orleans lost about 25,000 gallons of diesel fuel, which rapidly dissipated in the ocean and could not be tracked after a few days. There were no injuries to the New Orleans crew of 360 or the embarked unit of 700 USA Marines.

The nuclear powered submarine Hartford was severely damaged as its sail was torn from its mountings to the vessel's pressure hull. The submarine's communication masts and periscope were warped and became inoperable. The watertight integrity of the pressure hull became suspect, yet the Hartford transited on its own power on the surface to Bahrain, where it tied up to a military pier. The nuclear power plant was unaffected by the collision.

The Hartford ran aground in 2003 near La Maddalena, Italy damaging the bottom and rudder. Repairs involved the installment of equipment that was cannibalized from a decommissioned submarine.



Figure 39. The collision of the Hartford with the New Orleans on March 20, 2009 caused damage to its communication gear and bent its sail.

Table 11. Nuclear submarine accidents since 1968.

Accident	Location	Date
USA Navy submarine Scorpion sinks with 99 men aboard.	East of Norfolk, Virginia	May-June 1968
French submarine, The Eurydice sinks with 57 crew members	Off Saint Tropez, Mediterranean Sea	March 4, 1970
Soviet November Class nuclear attack submarine sinks with 88 crew members	Atlantic Ocean, off Spain	April 12, 1970
Explosion on a Russian submarine sends up the reactor lid 100 meters, claiming a maintenance crew of 10 people	Chazma Bay on the Pacific coast by Vladivostock	August 10, 1985
Soviet Mike Class submarine develops a fire with a loss of	Off northern Norway	April 7, 1989

42 lives		
Toxic fuel leaked from a ballistic missile and poisoned several Russian service men	Russia's far east	June 16, 2000
Russian Oscar-II Class submarine Kursk sinks with 118 crew members after a possible collision and two explosions onboard	Barents Sea	August 12, 2000
USA Navy 360 foot submarine, The Greenville sinks a Japanese fishing trawler after colliding with it in a resurfacing training maneuver, killing 9 sailors aboard the boat	Pacific Ocean off Pearl Harbor, Hawaii	February 9, 2001
Russian K-139 submarine sank while being towed to a shipyard with 9 crew members aboard		August 28, 2003
USA San Francisco runs into undocumented underground mountain, killing one crew member	Off Guam, Pacific Ocean	January 2005
Fire on board the Viktor-3 class Russian Navy submarine St. Daniel of Moscow kills 2 crew members	Moored near Finnish border	September 6, 2006
British submarine the Tireless during an exercise has 2 soldiers killed and 1 injured	Arctic Ocean	March 21, 2007
The Nerpa, Akula class Russian submarine fire causes the death of 20 people and injuring 21 while on sea trials	Pacific Ocean	November 8, 2008
The Hartford nuclear submarine while submerged but near the surface collides with the surface ship USS New Orleans. The collision caused 15 injuries on the Hartford.	Strait of Hormuz	March 20, 2009

ALL ELECTRIC PROPULSION AND STEALTH SHIPS

Three trends are shaping the future of naval ship technology: the all electrical ship, stealth technology and littoral vessels.

The all-electric ship propulsion concept was adopted from the propulsion system of cruise ships for the future surface combatant power source. It would encompass new weapon systems such as modern electromagnetic rail-guns and lasers under development.

Planned as an all-electric ship is the CVN-21 next-generation USA Navy aircraft carrier, scheduled for launch around 2011-2013 to replace the then half-century-old USS Enterprise CVN 65.

The CVN-21's new nuclear reactor not only will provide three times the electrical output of current carrier power plants, but also will use its integrated power system to run an Electro Magnetic Aircraft Launch System, EMALS to replace the current steam-driven catapults. Combined with an Electromagnetic Aircraft Recovery System, EARS, EMALS will enable the new carrier to conduct high-intensity aircraft launch and recovery operations consistently with minimal recovery or maintenance downtime.

To store large amounts of energy, flywheels, large capacitor banks or other energy storage systems would have to be used.

A typical ship building experience involved the design conversion of one class of submarines to an all-electric design. The electric drive reduced the propulsion drive system size and weight; eliminating the mechanical gearbox. However, the power system required extensive harmonic filtering to eliminate harmonic distortion with the consequence that the overall vessel design length increased by 10 feet.

Tests have been conducted to build stealth surface ships based on the technology developed for the F-117 Nighthawk stealth fighter. The first such system was built by the USA Navy as "The Sea Shadow."





Figure 40. The Sea Shadow stealth ship used radar deflecting technology used in the F-117 Nighthawk stealth fighter. Source: USAF.



Figure 41. Lockheed-Martin RQ-170 Sentinel Stealth Unmanned Aerial Vehicle (UAV) drone, known as the Beast of Kandahar. Source: Lockheed-Martin.



Figure 42. To hide it from satellite imaging, the Sea Shadow stealth ship was moored under the canopy of the “Hughes Miner Barge” that was allegedly used to retrieve a section of a sunken Russian submarine with possibly its code machine and weapons systems.



Figure 43. Stealth radar deflecting technology implemented into a French Lafayette class frigate, 2001.

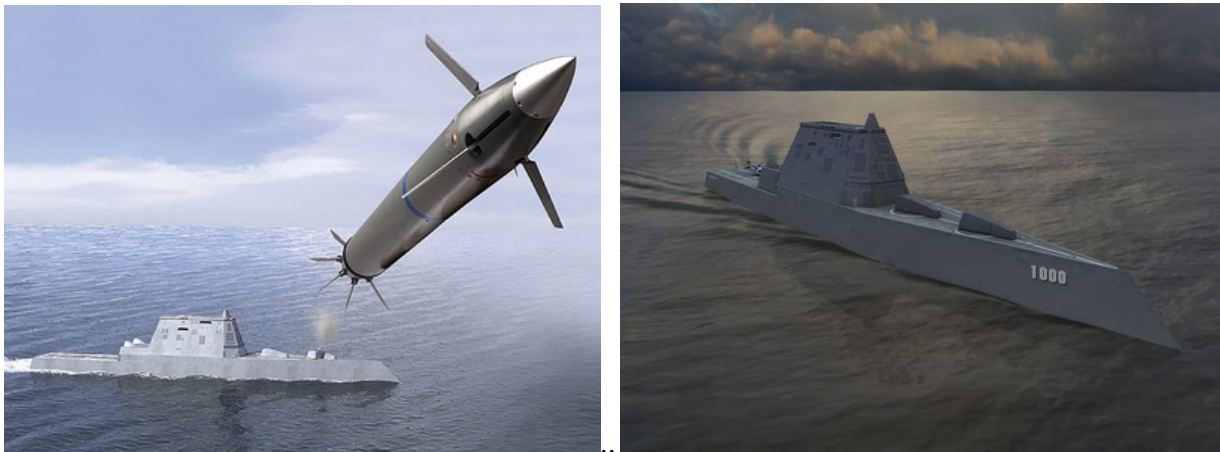

Figure 44. The DDG-1000 stealth destroyer is optimized for firing land-attack missiles; not Ballistic Missile Defense, BMD missiles. The Raytheon Company builds the DDG-1000's SPY-3 radar, and Bath Iron Works, the Maine shipyard builds the DDG-1000.

The threat from ballistic anti ship missiles and the potential of nuclear tipped missiles has slowed down the development of stealth surface ships. The USA Navy cut its \$5 billion each DDG-1000 stealth destroyer ships from an initially planned seven to two units.

Missile defense emerged as a major naval mission at the same time that the DDG-1000's stealth destroyer design limitations and rising costs converged, all while shipbuilding budgets were getting squeezed.

The SM-3 Standard missile, fired only by warships, is the most successful naval missile defense system; having passed several important trials while other Ballistic Missile Defense, BMD weapons are under testing. The ballistic-missile threat is such that the USA Navy decided it needed 89 ships capable of firing the SM-3 and that the DDG-1000 realistically would never be able to fire and guide the SM-3 since the stealth destroyer is optimized for firing land-attack missiles not Standard missiles.

The USA Navy has 84 large surface combatants, split between Arleigh-Burke Class destroyers and the Ticonderoga Class cruisers, capable of carrying the combination of Standard missiles and the BMD capable Aegis radar. The DDG-1000 cannot affordably be modified to fire SM-3s. So the Navy needs another 12 SM-3 "shooters" to meet the requirement for missile defense, and there was no time to wait for the future CG-X cruiser. With new amphibious ships, submarines, carriers and Littoral Combat Ships in production alongside the DDG-1000s, there was no room in the budget for five extra DDG-1000s.

LITTORAL COMBAT SHIP, LCS

Littoral Combat Ships are designed to operate closer to the coastlines than existing vessels such as destroyers. Their mission is signal intelligence gathering, insertion of special forces, mine clearance, submarine hunting and humanitarian relief. New missions involve pirates and drug smuggling interdiction.

The two firms Austal and Lockheed-Martin are to build 10 LCS apiece through 2015, each using their own distinct design. The cost per ship is \$450 million, at least \$200 million below the cost of each of four built prototypes.

The Lockheed-Martin's version has in its USS Freedom prototype the largest marine gas turbines in the world; essentially the engines of a Boeing 777 jetliner. The turbines' 100,000 horsepower can propel the LCS at up to 50 knots, compared to 30 for most warships. That high speed would use up a fuel supply in half a day.

The high speed could help the LCS respond better to pirate attacks and assaults by small fast boats. However, an extra 20 knots are not likely to make much difference against supersonic anti-ship missiles.

The 20 LCS ships would help the USA Navy reverse the slow decline of its 280-strong fleet. After retiring many of its minesweepers, patrol boats and frigates, the Navy does not have is enough low-end warships for all the mundane work of a busy, globally deployed military. The LCS can help correct that imbalance. This at a time when the USA Navy is not involved in at-sea combat, and instead spends much of its time in pirates and smuggler "other-than-war" tasks. In these cases, speed and sheer numbers of vessels o matter.

The LCS includes a large hangar for carrying Marine troops, manned helicopters, aerial drones and surface-skimming robots.

An ocean-going robot quiet sonar-equipped submarine chaser could come into service aboard the LCS.



Figure 45. Trimaran Littoral Combat Ship. Photo: Austal.

ANTI SUBMARINE WARFARE ASW CONTINUOUS TRAIL UNMANNED VESSEL, ACTUV

As new submarine classes achieve ever increasing levels of acoustic quieting and operational performance, tracking submarines has become more difficult. Some modern diesel-electric submarines are able to challenge conventional tracking approaches, risking future USA capability in the undersea battle-space. This creates the incentive for the Anti-Submarine Warfare, ASW Continuous Trail Unmanned Vessel, ACTUV program.

The ACTUV concept is based on an independently deployed unmanned naval vessel optimized for continuous trail of quiet submarines. It would be a clean sheet unmanned ship design with no person stepping aboard at any point in its operating cycle and enable a unique architecture for robust platform performance across a range of conventional and non-conventional.

The program seeks to advance autonomous operations technology with a goal of full compliance with safe navigation requirements while executing its tactical mission under a sparse remote supervisory control model.

It will leverage its unique characteristics to employ a novel suite of sensors capable of robustly tracking quiet diesel electric submarines to deliver a game changing operational capability.

Six contractor teams will support the development of concept designs for the ACTUV system: Northrop Grumman Undersea Systems, based in Annapolis, Maryland; Science Applications International Corp (SAIC) Intelligence, Security, and Technology Group, based in Long Beach, Mississippi.; Qinetiq North America Technology Solutions Group, based in Waltham, Massachusetts, the University of Washington Applied Physics Laboratory, in Seattle, Washington for testing of high frequency active sonar for acquisition and tracking of submarine targets; Spatial Integrated Systems, based in Kinston, North Carolina, for development and at-sea demonstration of unmanned surface vessel autonomous algorithms for submarine tracking and

Rules of the Road compliance; and Sonalysts based in Waterbury, Connecticut., for development of an exploratory crowd-sourced tactics simulator.

DIRECTED ENERGY WEAPONRY

FREE ELECTRON LASER, FEL TUNABLE LASER

The Free Electron laser is contemplated as a directed energy weapon system that can replace in the 2020s the radar-guided Phalanx gun used for close-in ship defense and used against rocket and mortar attacks.

Lasers require a medium to turn light into a directed energy beam. Solid state lasers use crystals and glass. Chemical lasers use gaseous media and toxic liquid materials. These two types generate the lasers at a specific wave length. The chemical lasers use toxic chemical reactants such as ethylene and nitrogen trifluoride.

Free Electron Lasers (FELs) do not need a gain medium and use a stream of energetic electrons to generate variable wave length lasers. An FEL system can adjust its wavelength for a variety of tasks and to cope with different environmental conditions. It can also run from a vessel's electrical power supply rather than its own, and does not need to stop and reload. Such a system for naval vessel needs to have a power of 100 kW. More than that would be needed to counter anti-ship ballistic missiles.

The tunable laser is a desirable feature since particles in the sea air, like condensation, can reduce the effectiveness of a defined wavelength laser. The Free Electron laser can fire at different points along the spectrum picking out the frequency that would penetrate the moist air.

The FEL is composed of a relativistic electron tube that uses an oscillator and an open optical resonator running at 10 percent efficiency. An electron beam is injected into a high gain amplifier series of alternating magnets called a "wiggler." In the wiggler, the electron beam bends or wiggles back and forth undergoing acceleration and emitting coherent laser radiation.

It can be used for multiple uses, for instance as a sensor for detection and tracking when it is not used to hit an incoming missile. It could also be used for location, time-of-flight location, information exchange, communications, for target location and for disruption of radar and communications.

Electrical generators planned in the all-electric fleet can have a capacity of about 2 MW of power, and can easily provide the future MW level of power to the FEL, particularly if more than one generator is installed on a given ship. The electron accelerator has to eventually be shrunk in size to fit on a naval vessel.

ELECTROMAGNETIC RAIL GUN

A 32 MJ rail gun can generate a projectile travelling 10 nautical miles in 6 minutes. A 64 MJ gun the projectile would travel 200 miles in six minutes.

A rail gun powered from a ship's electrical supply can shoot 20 rocket propelled artillery shells in less than a minute on targets 63 nautical miles away. Two rail guns would have the firepower of a 640 persons artillery battalion.

A plasma armature method of propulsion is used where a plasma arc is generated behind the metallic projectile along copper rails.

The rounds would travel at 6 km/sec. This means that the rounds fired per ship would increase from 232 to 5,000. These inert rounds also travel at around Mach 7, carrying a large amount of kinetic energy at double the energy of conventional explosive shells. The force of the projectile hitting a target have been compared to hitting a target with a medium size car at 380 mph. They would also travel farther to 200-300 nautical miles.

Each projectile would cost about \$1,000, whereas a cruise missile would cost about \$1,000,000. A ship can have thousands of the small projectiles stored on board instead of just about 100 cruise missiles.

The key technology hurdle is the development of an intermediate energy storage system that can release the power as needed. From a pulse-capacitor storage approach, those systems exist today. Ships, by the very nature of their size, have the amount of energy available and those will be seen there long before they are seen on aircraft or tanks or wheeled vehicles, because of the power availability.

For a rail-gun system, the capacitors can be charged for several seconds, then discharged in milliseconds. Achieving those levels of power in a system small enough to fit on a ship requires high energy densities. Volumetric energy densities of 4 joules/cm³ were achieved during the 1980s; and capacitors storing 40,000 joules were built.

Higher densities in smaller scales, on the order of 5.8 joules/cm³ are currently achievable with a goal of 8 joules/cm³ that is approaching a level where a rail gun can be installed on a tank.

HIGH POWERED MICROWAVE, HPM BEAMS

A "defense-suppression mission" involves taking out air defenses, radars, missile launchers and command centers. It can be achieved by degrading, damaging or frying their electronics using directed microwave beams.

Directed energy microwave weapons have been successfully used to destroy buried Improvised Explosive Devices (IEDs) in Iraq.

Cryogenic technology can be used to develop a high-power microwave active denial system. This allows the setting up of an electric fence around an area to prevent people from entering it.

For a ship at sea, a perimeter can be set around the ship. It would be designed to be non-lethal heating up the skin up very fast and would force an intruder to turn away. The primary interest in the USA Navy is for protecting shore facilities."

MULTIPURPOSE FLOATING BARGES

The vision of floating barges with nuclear reactors to produce electrical power for industrial and municipal use, hydrogen for fuel cells, as well as fresh desalinated water at the shores of arid areas of the world may become promising future prospects. The electricity can be used to power a new generation of transportation vehicles equipped with storage batteries, or the hydrogen can be used in fuel cells vehicles.

An urban legend is related about a USA Navy nuclear submarine under maintenance at Groton, Connecticut, temporarily supplying the neighboring port facilities with electricity when an unexpected power outage occurred.



Figure 46. Multi-purpose Military Barge concept.

This would have required the conversion, of the 120 Volts and 400 Hz military electricity standard to the 10-12 kV and 60 Hz civilian one. Submarines tied up at port connect to a connection network that matches frequency and voltage so that the reactors can be shut down. The two electrical generators on a typical submarine would provide about $3 \text{ MWe} \times 2 = 6 \text{ MWe}$ of power, with some of this power used by the submarine itself. In case of a loss of local power, docked vessels have to start their reactors or their emergency diesel generators anyway.

ANTISUBMARINE WARFARE, ASW

Submarines are vulnerable to deep underwater nuclear explosions. Anti Submarine Warfare (ASW) uses conventional torpedoes as well as nuclear devices. The Wigwam nuclear underwater test was conducted on May 15, 1955. It used an underwater 30 kT TNT-equivalent charge. It took place 450 miles SW of San Diego, California in the open ocean. The device had to be reinforced for operation at the large pressures encountered at great water depth. It was a large 8,250 lbs (5,700 lbs when submerged) B7 Betty depth charge suspended with 2,000 feet cable from a floating barge. A shock wave resulted with the fireball rising to the water surface.



Figure 47. Wigwam B3 Betty nuclear depth charge test in open water off San Diego, California. May 15, 1955.



Figure 48. Nuclear B57 depth charge Anti Submarine Warfare (ASW) device.

A navy Lockheed S3 carrier-based aircraft was used as a delivery vehicle for both conventional torpedoes and nuclear charges. It was used as aircraft carrier ASW defense. It was equipped with a surface search radar and could drop sono-buoys submarines listening devices.



Figure 49. The Navy Lockheed S3 ASW aircraft has been withdrawn from service.

A side effect of underwater shock waves is the oceanographic effect of bottom bounce. In this case, a sound wave would be reflected or refracted from water layers of different salinities or temperatures. It could be reflected back from the ocean's bottom and can divert uncontrolled substantial amounts of energy miles away on subsurface and surface floating structures.

APPENDIX

SHIPPINGPORT PRESSURIZED WATER REACTOR AND LIGHT WATER BREEDER REACTOR

The Shippingport power station, first operated in December 1957 and was the first USA's commercial nuclear power reactor operated by the Duquesne Light Company. It was a pressurized water reactor with the first two reactor cores as "seed and blanket" cores. The seed assemblies had highly enriched uranium plate fuel clad in zirconium, similar to submarine cores, and the blanket assemblies had natural uranium.

The first core, PWR-1, had 32 seed assemblies with each seed assembly including four subassemblies for a total of 128. Each subassembly contained 15 fuel elements for a total of 1920. The U^{235} loading for the first seed core 75 kgs and the subsequent seeds had 90 kgs loadings.

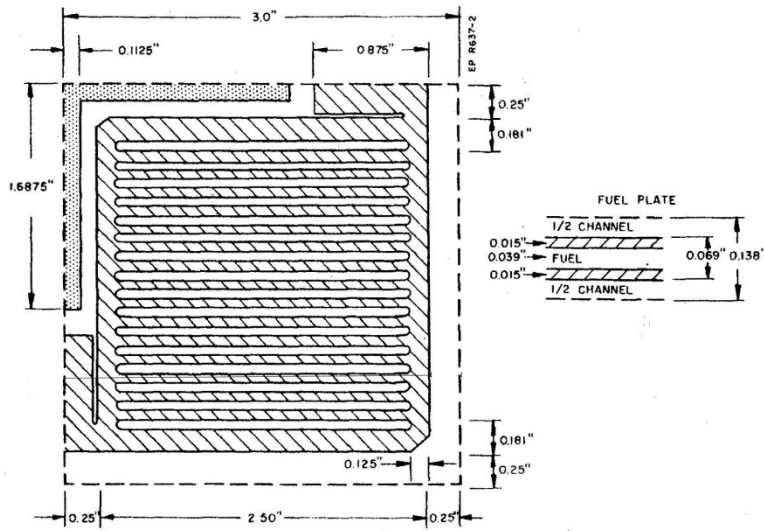

Figure I. Shippingport Reactor PWR-1 seed subassembly showing the highly enriched zirconium clad fuel and coolant channels. Dimensions in inches.

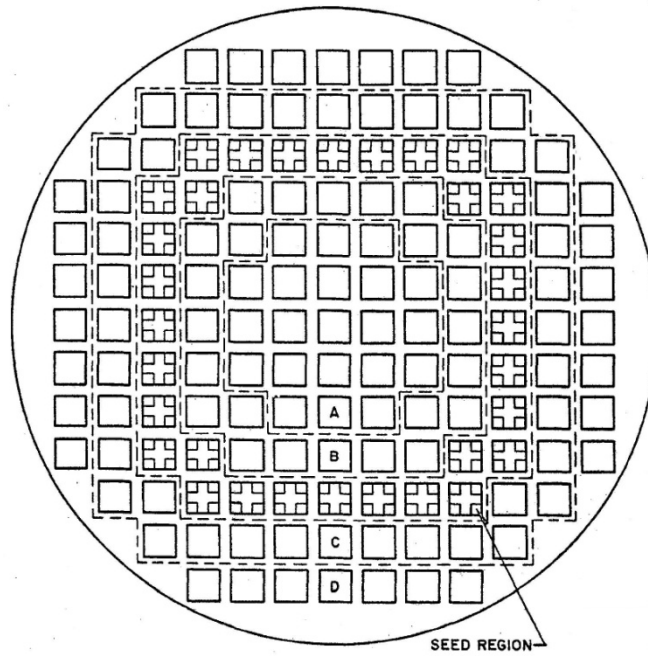

Figure II. Cross section of Shippingport PWR-1 core showing the seed region and the blanket regions A, B, C and D.

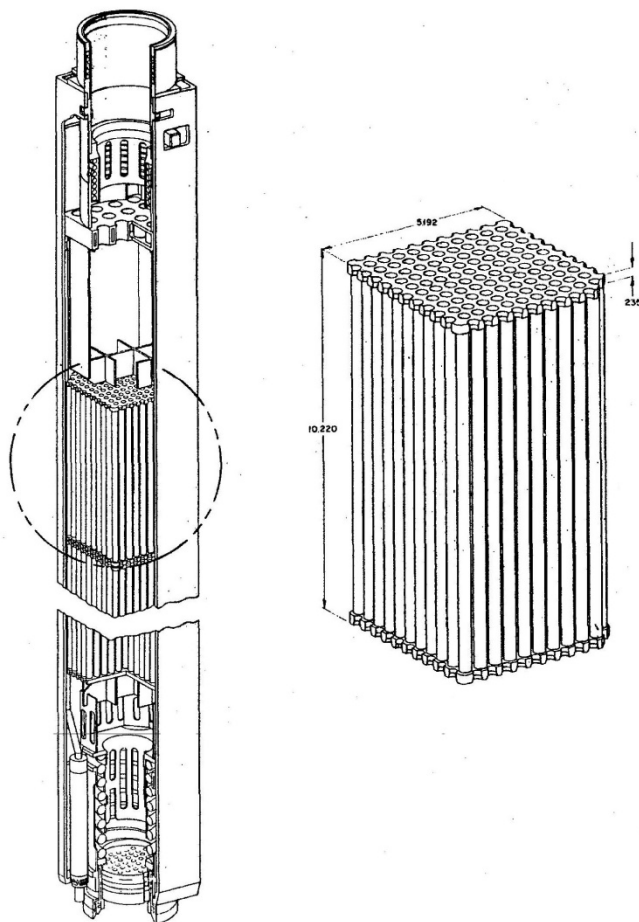

Figure III. Shippingport reactor blanket fuel assembly.

The PWR-1 blanket fuel was made of natural uranium in the form of natural UO_2 pellets clad with Zircaloy tubes. Each blanket assembly was made from seven stacked fuel bundles. Each fuel bundle was an array of short Zircaloy tubes with natural uranium oxide pellets in the tubes. PWR-1 had 113 blanket assemblies each containing seven fuel bundles for a total of 791, and each bundle contained 120 short fuel rods for a total of 94,920. The natural uranium loading for the blanket fuel was 12,850 kgs of natural uranium.

Subsequently, the Shippingport blanket was replaced by a thorium control assembly to introduce the light water breeder concept where U^{233} is bred from Th^{232} in a thermal neutron spectrum.

EXERCISE

1. For a reactor fueled with U^{235} , $\nu = 2.42$, $p = 0.8$, $\epsilon = 1.05$, calculate the value for the reactivity ρ for equilibrium xenon.

REFERENCES

1. M. Ragheb, "Lecture Notes on Fission Reactors Design Theory," FSL-33, University of Illinois, 1982.
2. John Lamarsh, "Introduction to Nuclear Engineering," Addison-Wesley Publishing Company, 1983.
3. Raymond L. Murray, "Nuclear Energy," Pergamon Press, 1988.
4. John G. Collier and Geoffrey F. Hewitt, "Introduction to Nuclear Power," Hemisphere Publishing Corp., Springer Verlag, 1987.
5. D. L. Broder, K. K. Popkov, and S. M. Rubanov, "Biological Shielding of Maritime Reactors," AEC-tr-7097, UC-41, TT-70-5006, 1970.
6. Caspar W. Weinberger, "Soviet Military Power," USA Department of Defense, US Government Printing Office, 1981.
7. T. R. Reid, "The Big E," National Geographic, January 2002.
8. David I. Poston, "Nuclear design of the SAFE-400 space fission reactor," Nuclear News, p.28, Dec. 2002.
9. Ole Reistad and Povl L. Olgaard, "Russian Power Plants for Marine Applications," NKS-138, Nordisk Kernesikkerhedsforskning, April 2006.