

650 Flexible Disc File

OEM Manual

2944.010

MEMOREX

**Disc Storage
Products**

Memorex 650 Flexible Disc File OEM Manual



© 1972, MEMOREX CORPORATION

Table Of Contents

<u>SECTION</u>	<u>PAGE</u>
INTRODUCTION	1
GENERAL DESCRIPTION	1
DESIGN FEATURES	1
SPECIFICATIONS SUMMARY	3
FUNCTIONAL CHARACTERISTICS	5
GENERAL OPERATION	5
LOGIC AND ANALOG FUNCTIONAL DESCRIPTIONS	8
Control Logic	8
Write and Safety Logic	10
Read Logic	11
TIMING SEQUENCES	12
Initial Mode of Operation	12
Track Access Mode of Operation	13
Write or Read Mode of Operation	13
DATA FORMAT	15
INSTALLATION	19
ENVIRONMENT	19
CONNECTORS AND CABLES	19
MOUNTING DIMENSIONS	21
WEIGHT	21
OPTIONAL MOUNTING DIMENSIONS (CHASSIS SLIDES)	21
INTERFACE DESCRIPTION	25
GENERAL	25
CONTROL	25
Input	27
Output	28
DATA	28
POWER	29

Table Of Contents (Cont)

<u>SECTION</u>	<u>PAGE</u>
INTERFACE CIRCUITRY	30
Control Interface Circuitry	30
Data Interface Circuitry	31
OPERATING PROCEDURES	33
CARTRIDGE LOADING AND HANDLING	33
ERROR DETECTION AND CORRECTION	34
Write Error	34
Read Error	35

List Of Illustrations

<u>FIGURE</u>		<u>PAGE</u>
1	650 Functional Diagram	6
2	Head Load Mechanical Assembly	7
3	Disc Cartridge and Disc Configuration	8
4	Initial Sequence	12
5	Typical Write Sequence	14
6	Write Data Timing Function	14
7	Separated Clock and Data	15
8	Sector Recording Format	16
9	Index Recording Format	17
10	Signal Connector Keying	20
11	Flexible Disc Mounting Dimensions	22
12	Flexible Disc Mounting Dimensions (Chassis Slides)	23
13	Flexible Disc Wiring Diagram	26
14	Control Line Driver and Line Receiver	30
15	Write Data Signal and Driver	31
16	Separated (SEP) Data and Clock Signals and Receivers	32
17	Cartridge Loading	33

List Of Tables

<u>TABLE</u>		<u>PAGE</u>
1	SPECIFICATIONS SUMMARY	3
2	TEMPERATURE-HUMIDITY RANGES FOR FILE AND DISC CARTRIDGE	19
3	CONNECTORS SUPPLIED BY USER	20
4	INPUT CONTROL SIGNALS	27
5	OUTPUT CONTROL SIGNALS	28
6	DATA SIGNAL INTERFACE	28
7	POWER PARTITIONING	29

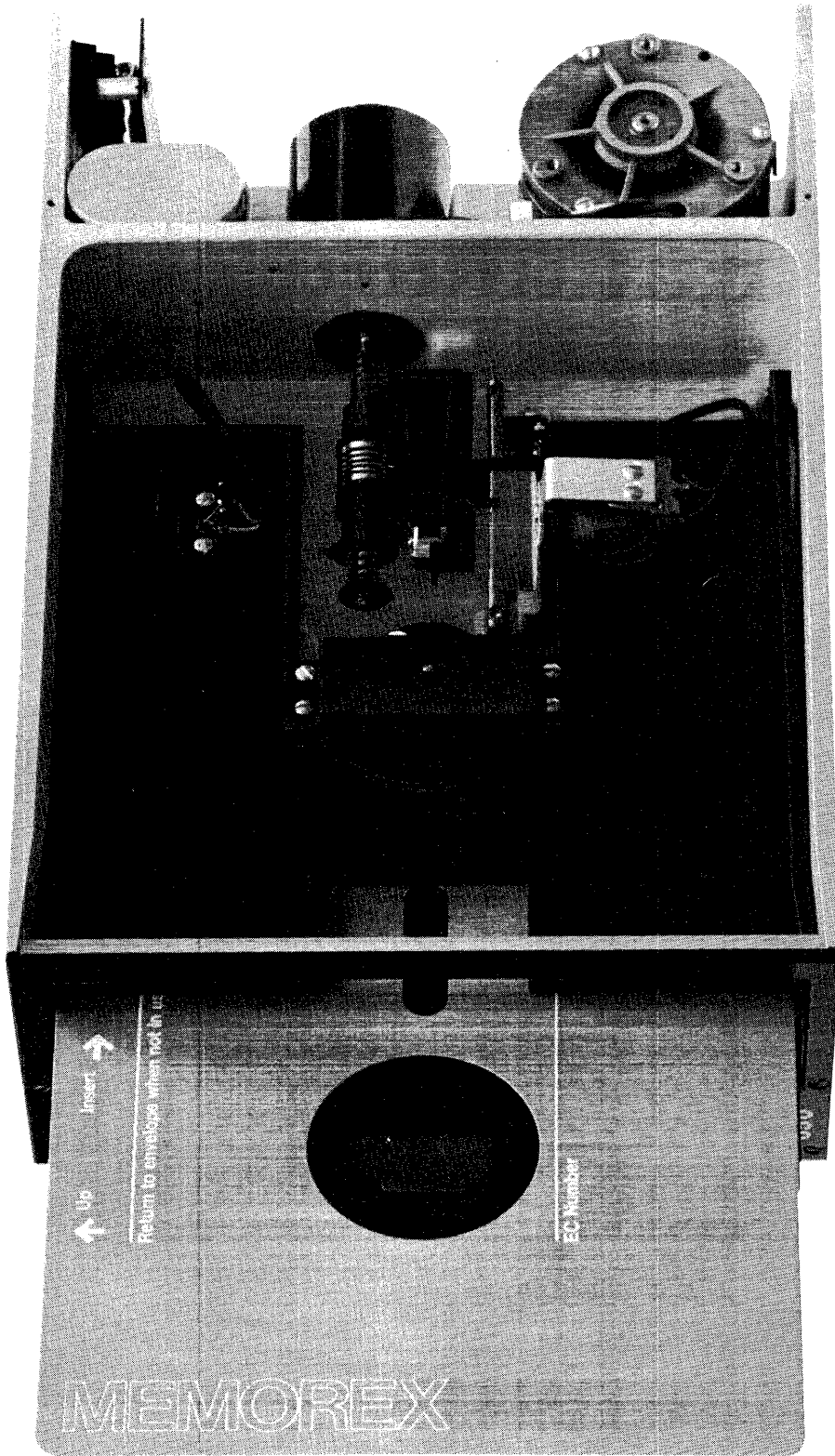

Introduction

GENERAL DESCRIPTION

The Memorex 650 Flexible Disc File is a compact, direct access, removable disc unit intended to simplify the distribution, processing and storage of digital information.

The 650 is designed for applications that demand data handling simplicity and convenience, plus a high degree of operational reliability. Typical applications for the 650 are control store loading, auxiliary storage, data logging, key-entry recording, programmable calculator storage, point-of-sale recording and accounting machine storage.

The 650 is composed of a drive mechanism, read/write head, head actuator and associated electronics. Connections are made to the host system by signal and power cables with addressing, function requests, data formatting and power supplied by the user.

The 650 can write and read discs interchangeably from unit to unit. For those applications not requiring a write capability, a read-only option is available.

The FD/III Flexible Disc Cartridge used in the 650 is a flat disc composed of a Mylar® substrate coated with a magnetic oxide. For protective purposes during handling, operation and storage, the disc is encased in a flexible plastic envelope, eight inches square by one-sixteenth inch thick.

DESIGN FEATURES

The 650 includes the following operational features:

Digital Applications Oriented

Designed specifically for digital data processing applications. Its unique design makes it an attractive alternative to tape cassettes, tape cartridges, paper tape, or card readers.

High Performance Parameters

The 1.5 megabit capacity, 200K bps transfer rate, and random access capability, makes it an ideal device for applications requiring low-cost, on-line data storage.

Read/Write Capability	Designed to be used as a file in applications requiring recording and retrieving of data on a disc interchangeable basis.
Compact	Small and compact allows the designer more freedom for integration into a system.
Interlocks	Contains interlocks which prevent damage to a disc during loading or unloading.
Write Protect	Logic is provided to disable the write circuits should the user wish to protect data recorded on the disc.
Reliability	Designed for trouble-free operation with exceptionally reliable data handling capabilities.

OPTIONS

The following options can be provided with the 650:

Power	Available for 220 Vac 50/60 Hz applications.
Read Only	It can be ordered as a read-only device. All operating characteristics are the same except that the write functions are omitted.
Prerecorded Disc Service	Memorex provides the service of writing discs to the customer's requirements. By utilizing this service, a customer receives verified prerecorded discs certified to be error free.
Chassis Slides	Available with chassis slides where there are space limitations and easier accessibility is desired for servicing.

SPECIFICATIONS SUMMARY

Table 1 contains a summary of 650 specifications.

TABLE 1. SPECIFICATIONS SUMMARY

DATA RETRIEVAL TIMES	
Rotational Speed	375 rpm
Track to Track Access Time	20 msec
Data Transfer Rate	200 kilobits/sec.
DISC CHARACTERISTICS	
Number of Tracks	50
Recording Density	2400 bits per inch (inside track)
Record Length Sectorized (8 per track)	3.5 kilobits
Record Length Indexed (1 per track)	30 kilobits
Disc Capacity Sectorized	1.4 megabits
Disc Capacity Indexed	1.5 megabits
DATA RECORDING FORMAT	
Recording Mode	Frequency modulation
Sectors per Track	8
Index per Track	1

Functional Characteristics

GENERAL OPERATION

The 650 consists of control and read/write electronics, disc drive motor, read/write head, head actuator, track access mechanism, and removable disc. The primary functions performed by the 650 are:

- Receive and generate control signals
- Access the appropriate track
- Write or read data upon command

The internal functions of the 650 and the required interface signals to and from the using system are shown in Figure 1. The Read, Write, Safety and Control Logic are the interface electronics between the user system and the 650. The Track Positioning Actuator positions the read/write head to the desired track on the disc. The Head Load Actuator loads the disc against the read/write head and data may then be recorded or read from the disc. Each of the logic blocks and signal names shown are later discussed under Logic and Analog Functional Descriptions.

The electronics are packaged on one PCB. The PCB contains:

1. Sector/Index Detector Circuits
2. Track Position Actuator Driver
3. Head Load Actuator Driver
4. Read/Write Amplifier and Transition Detector
5. Data/Clock Separation Circuits
6. Safety Sensing Circuits

An electrical stepping motor (Track Position Actuator) and lead screw positions the read/write head. The stepping motor rotates the lead screw clockwise or counterclockwise in 15° increments. A 15° rotation of the lead screw moves the read/write head one track position. The using system increments the stepping motor to the desired track. Track verification is accomplished by checking track addresses.

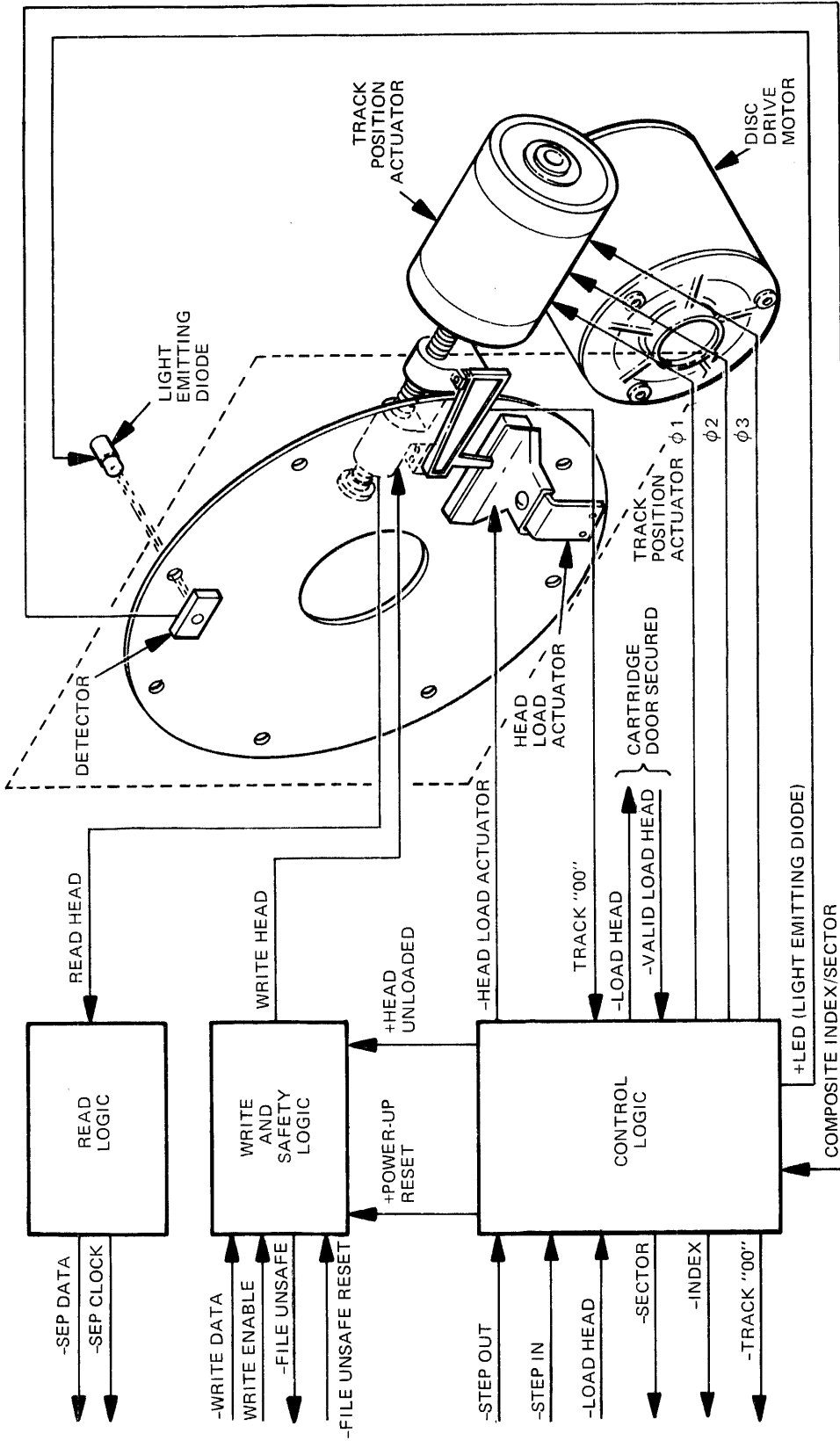

00562

Figure 1. 650 Functional Diagram

The disc drive motor rotates the spindle at 375 rpm through a belt-drive system. 50 or 60 Hz power is accommodated by means of a stepped pulley. A registration hub, centered on the face of the spindle, positions the disc. A clamp (that moves in conjunction with the insertion door) fixes the disc to the registration hub.

The read/write head is in direct contact with the disc. The head surface has been designed to obtain maximum signal transfer to and from the magnetic surface of the disc with minimum head/disc wear. The write portion of the head is wider than the read portion. When reading with a narrow head, a normal deviation from the center of the track does not affect the signal-to-noise ratio, and permits disc interchangeability from unit to unit.

The read/write head is mounted on a carriage that is moved by the lead screw. As shown in Figure 2, head load is achieved when the disc is lightly loaded against the rigidly mounted head by moving a load pad against the disc with a solenoid actuated bail. Head to disc compliance is achieved by restraining the disc between the head and the load pad.

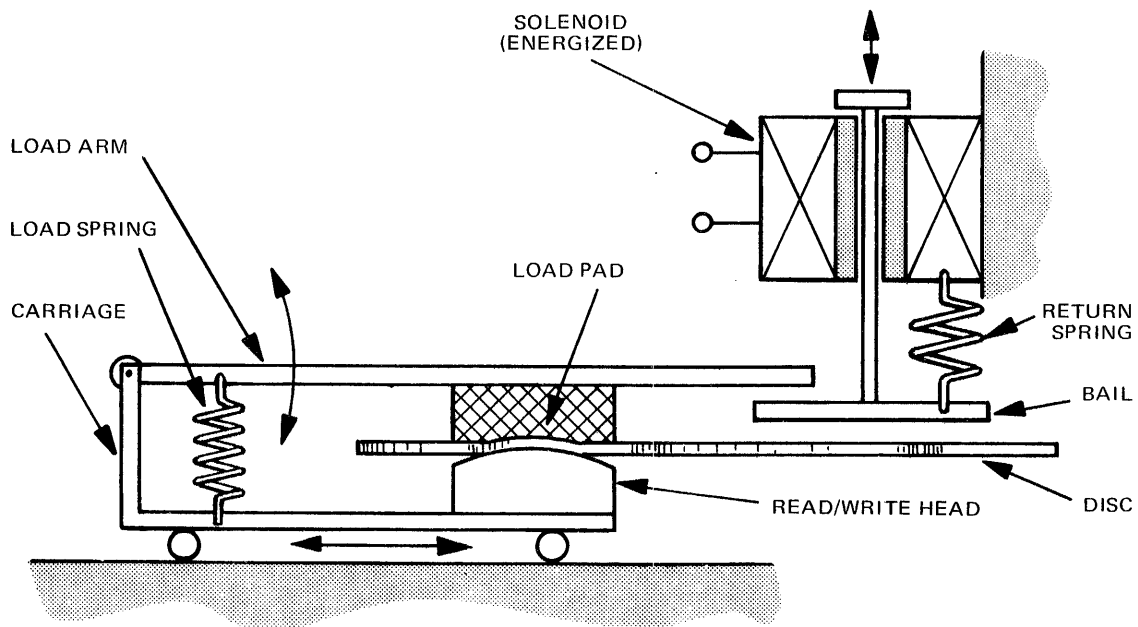

Figure 2. Head Load Mechanical Assembly

00563

The disc is vertically mounted in the 650. It rotates at 375 rpm in a plastic envelope, which protects and cleans the recording surface during operation. The disc, 7.5 inches in diameter, has eight holes spaced around the periphery for sector definition. There is also one additional hole for indexing. Figure 3 shows the disc cartridge and disc configuration.

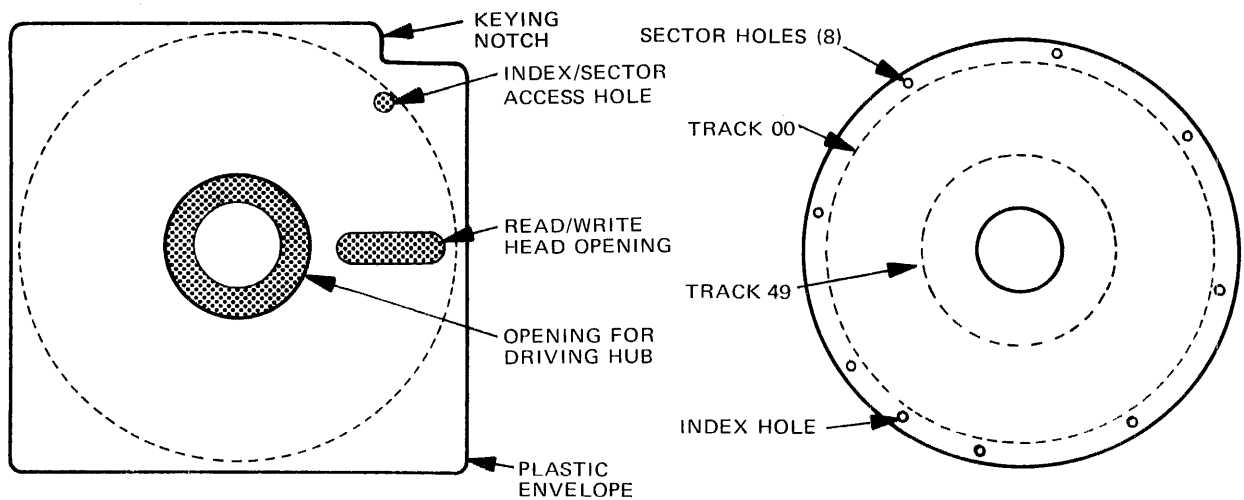

Figure 3. Disc Cartridge and Disc Configuration

00564

LOGIC AND ANALOG FUNCTIONAL DESCRIPTIONS

This section discusses each logic block and signal name shown in Figure 1. The descriptions are divided into each of three logic blocks: Control, Write and Safety, and Read. All input interface functions are generated by the user. All output interface functions are generated by the 650.

Control Logic

The basic functions of the Control Logic are to place the read/write head on the proper track, hold the disc against the head for write or read operations, and indicate disc rotational position. User interface functions are as follows:

STEP OUT

Increments the Track Position Actuator. Each pulse moves the head one track outward from the center of the disc.

STEP IN	Increments the Track Position Actuator. Each pulse moves the head one track inward toward the center of the disc.
LOAD HEAD	Loads or unloads the disc from the read/write head.
SECTOR and INDEX	Provides disc sector and index position information. Each signal is a separate output. These pulses are generated from equally spaced holes located around the periphery of the disc (Figure 3) and are used for the formatting and orientation of data on the disc.
TRACK 00	Indicates when the read/write head is located at Track 00.

Transducer signals between the 650 Control Logic and electromechanical assemblies are as follows:

POWER-UP RESET	Resets the internal logic to the proper state when power is turned on.
HEAD UNLOADED	Logic signal to the Write and Safety Logic to insure that the disc is loaded against the read/write head before write operations begin.
HEAD LOAD ACTUATOR	Energizes the solenoid shown in Figure 2. It is a function of LOAD HEAD (user supplied).
TRACK 00	Switch closure indicating that the read/write head is located at Track 00.
LOAD HEAD, VALID LOAD HEAD	Switch closure interlock indicating that the cartridge door is secured. If this condition is not satisfied, the read/write head cannot be loaded.

TRACK POSITION ACTUATOR	Driving function to increment the Track Position Actuator motor clockwise or counterclockwise. It is a function of STEP OUT or STEP IN.
LED	Provides power to the Light Emitting Diode (LED).
COMPOSITE INDEX/SECTOR	Detector signal input to the Control Logic. As shown in Figure 3, eight holes (0.10 inches diameter) divide the disc into equal sectors. The ninth hole (same diameter) spaced midway between two sector holes indicates one disc revolution. The LED and Detector (photo transistor) are placed on opposite sides of the disc (Figure 1). As the disc revolves, the holes pass between the LED and Detector illuminating the Detector and turning it on. The Detector output is shaped by a threshold detector and an output pulse is obtained. Output is normally at +5 Volts with a transition to 0 Volts for the pulse. Internally within the Control Logic, the INDEX and SECTOR signals are separated and are transmitted via separate interface lines to the user.

Write and Safety Logic

The basic function of the Write and Safety Logic is to convert digital data received from the user into analog form for recording on the disc, and to insure that the file is in proper condition before recording begins. User interface functions are as follows:

WRITE DATA	A user generated composite signal consisting of alternating data and clock.
WRITE ENABLE	A gating function activated during the write operation. This signal is used to control the recording of data on the proper track and sector.

FILE UNSAFE

Any one of the underlisted electronic conditions within the 650 can produce this signal and disable the write driver circuits:

1. Write enable and no write current.
2. Write current and no write enable.
3. Write enable and head not loaded.
4. Write enable and no write data.

FILE UNSAFE RESET

Resets a latch in the Write and Safety Logic block when conditions have been corrected which produced the FILE UNSAFE signal. Initially, when power comes on, the latch is reset automatically within the 650. Manual intervention is recommended for this function.

Transducer signal communication between the 650 Write Logic and the write head is as follows:

WRITE HEAD

Supplies current to the write head. The direction of this current reverses each time a WRITE DATA pulse is received.

Read Logic

The basic function of the Read Logic is to receive pulses from the disc and convert this composite signal into separate clock and data lines. Data and clock come from the Read Logic block when the disc is loaded onto the head. User interface functions are as follows:

SEP DATA

Digital data bits read from the disc.

SEP CLOCK

Digital clock bits read from the disc.

Transducer signal communication between the 650 Read Logic and the read head is as follows:

READ HEAD

An analog representation of the recorded information described previously for WRITE DATA and WRITE HEAD. This signal is amplified, differentiated, limited, and then shaped. The shaped data is input to a data separator circuit which separates the data bits from the clock bits.

TIMING SEQUENCES

The 650 timing sequences are divided into the following three modes of operation: Initial, Track Access, and Write or Read. The Initial mode is used when the power is turned on. During normal operation, the desired track is located with Track Access, and either Write or Read is performed. Unless otherwise noted, all signals shown on the timing sequences are to or from the using system.

Initial Mode of Operation

The initial timing is shown in Figure 4.

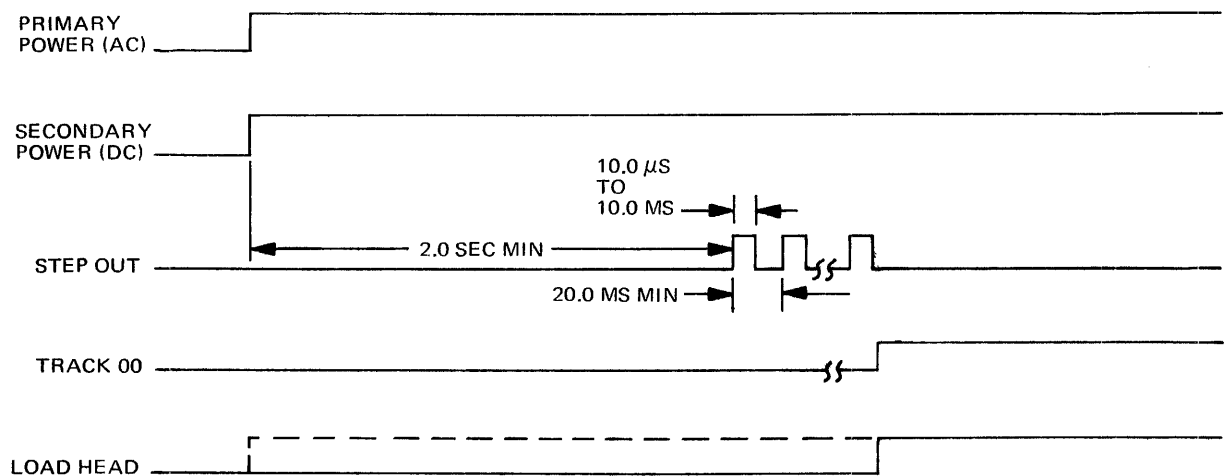

Figure 4. Initial Sequence

00565

The user applies PRIMARY and SECONDARY POWER to the 650. After a two-second delay (user provided) from power on, STEP OUT is applied until the read/write head is positioned at Track 00. This operation is performed to insure that the head is properly oriented before a read or write operation begins. When the head is positioned at Track 00, the TRACK 00 signal becomes true. It changes to false when the head leaves that track.

Memorex recommends that the user have some type of add/subtract track counter available. This counter would be reset to zero at Track 00. During normal write or read operations, the read/write head could be moved from track to track at random, and the track counter would always indicate the proper track location.

The LOAD HEAD signal can be applied any time after the power has been turned on. When the LOAD HEAD line is false, the read/write head is unloaded from the disc. The disc must be loaded on the head before a write or read operation can begin. At the user's option, this signal can be made true at the same time as power is applied to the 650 and will remain on until power is removed, or it can be applied when the head has been positioned at Track 00. Preferably, the former option should be used since it minimizes disc wear during track to track accessing. If a read, write, or head positioning command is not executed within four revolutions of the disc, the head should be unloaded.

Track Access Mode of Operation

The STEP OUT and STEP IN functions are used for positioning the read/write head to the desired track. The only restriction placed on these signals is that each pulse must be spaced by at least 20 msec. The STEP IN pulse width is the same as the pulse width for STEP OUT shown in Figure 4.

Write or Read Mode of Operation

The write and read timing sequences are basically the same. They are discussed separately for clarity. As stated previously, the read/write head must be loaded with LOAD HEAD before a write or read operation can begin.

Write. Figure 5 shows a typical write timing sequence.

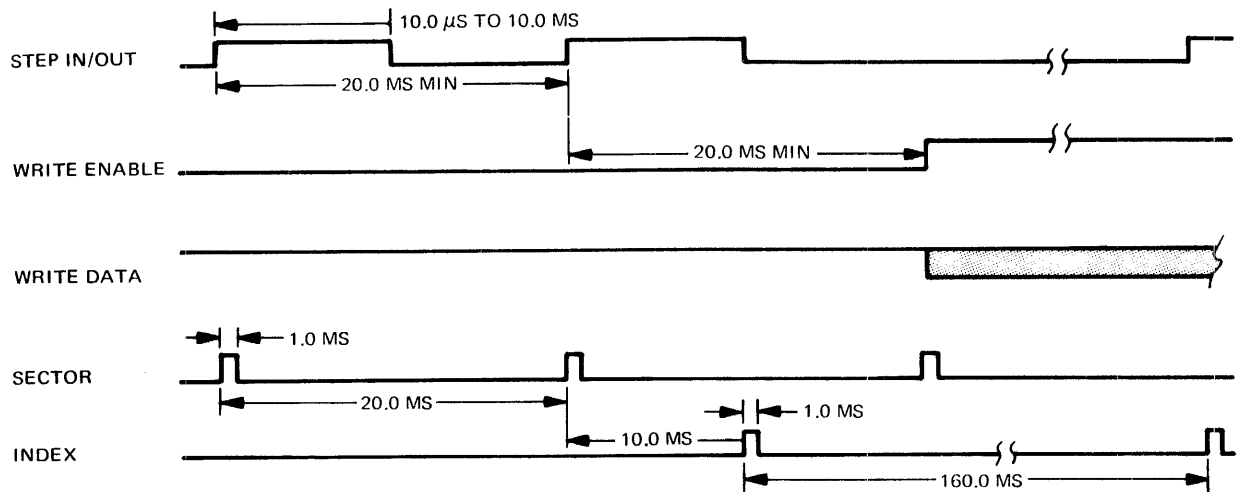

Figure 5. Typical Write Sequence

00566

WRITE ENABLE can be made true 20 msec after the leading edge of the last desired STEP IN or STEP OUT pulse has occurred. WRITE DATA may begin when WRITE ENABLE is true. Even though SECTOR and INDEX are asynchronous relating to the track access and head load mechanisms, they are shown here to suggest that the user should synchronize these functions with WRITE ENABLE to achieve maximum data storage on the disc.

An example of the WRITE DATA function is shown in Figure 6.

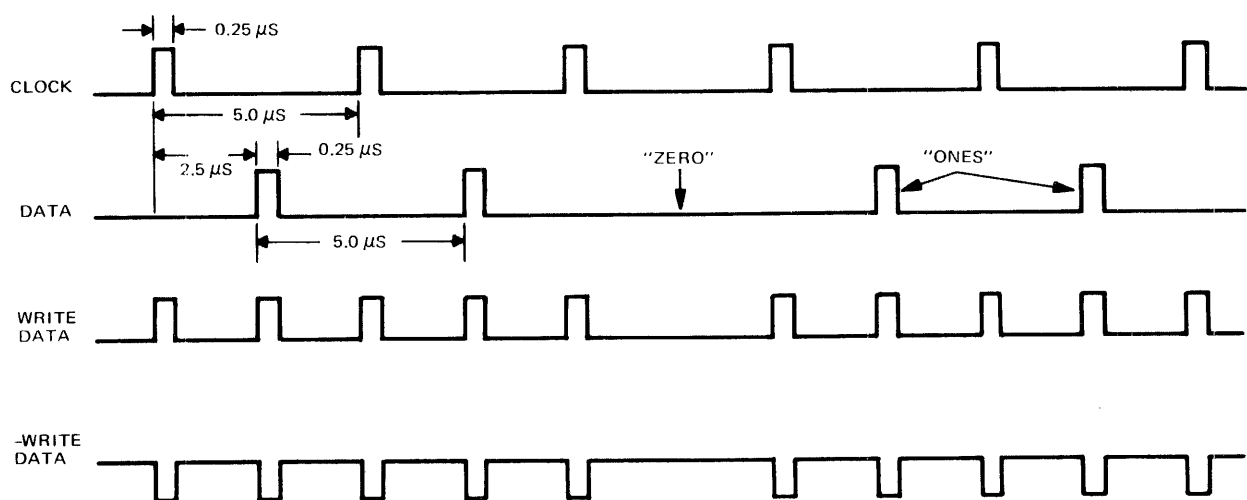

Figure 6. Write Data Timing Function

00567

The using system must generate separate CLOCK and DATA. These functions are combined into the composite WRITE DATA input to the 650. CLOCK and DATA should have logic gates to control their respective functions for proper formatting on the disc.

Read. For read operations, the output functions SEP DATA and SEP CLOCK can be substituted for WRITE DATA in Figure 5. Even though data is outputted immediately when the disc is loaded on the read/write head, reading should not start until the STEP IN or STEP OUT accessing has been completed. The user could accomplish this gating with a Read Enable function which would be used the same as for WRITE ENABLE. As suggested previously for Write, the user should use the SECTOR or INDEX pulses for gating output data from the 650. One of these functions would be connected to Read Enable (user provided) for proper synchronization.

Figure 7 is a representation of the SEPARATED CLOCK and SEPARATED DATA pulses as they are provided to the using system.

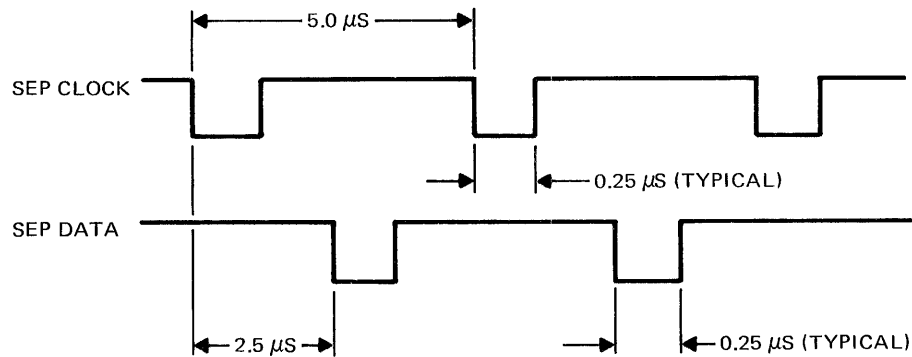

Figure 7. Separated Clock and Data

00568

DATA FORMAT

The user should optimize the data format to achieve maximum data storage and accessibility. The following paragraphs give two examples of data formatting.

Data can be organized in multiple records/track (sector) format or a single record/track (index) format. At the beginning of each record, 192 clock bits are required for synchronization of the internal data separator. Following the clock bits, two or more "data identifier" bytes (specified

by the user) are required for data synchronization and to recognize the start of data. Typically, the data identifier consists of two 8-bit bytes. In Memorex products that utilize the 650, two bytes of HEX 32 are used. For ease of searching and record verification, each data identifier block may be followed by one address byte consisting of track and sector identification. In applications where data integrity is critical, the address byte should be read to verify track and sector location before attempting a write operation. A read back check is recommended after the write operation.

Using sector format, the data is recorded with eight records per track. This format is shown in Figure 8.

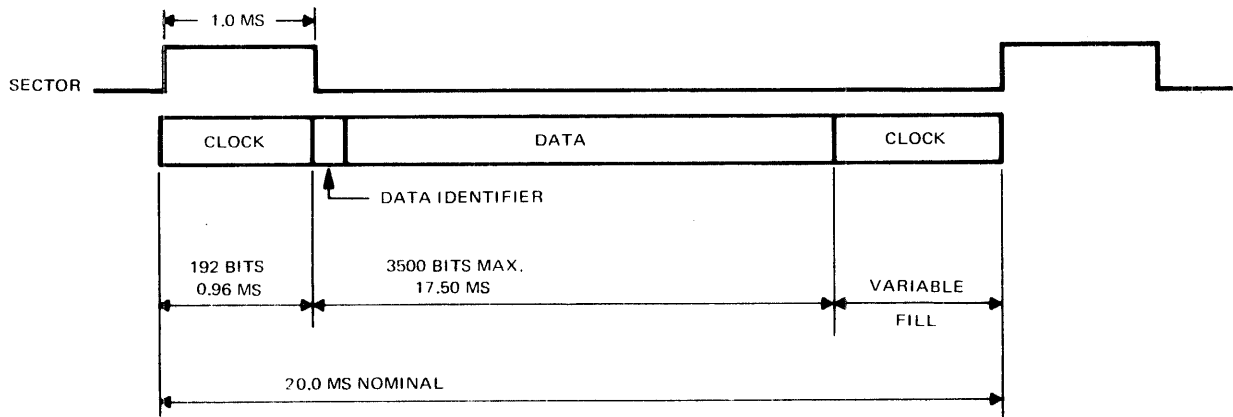

Figure 8. Sector Recording Format

00569

To generate this format, the user would input clock and data to the WRITE DATA line. At the beginning of the SECTOR pulse, WRITE DATA is enabled and 192 clock bits must be generated. At this point, the data and clock are combined on the WRITE DATA line and transmitted to the 650 for a maximum of 3500 data bits. The data is then stopped and the clock continues for the remainder of the 20 msec time period.

Figure 9 shows the index format. Data is recorded with one record per track.

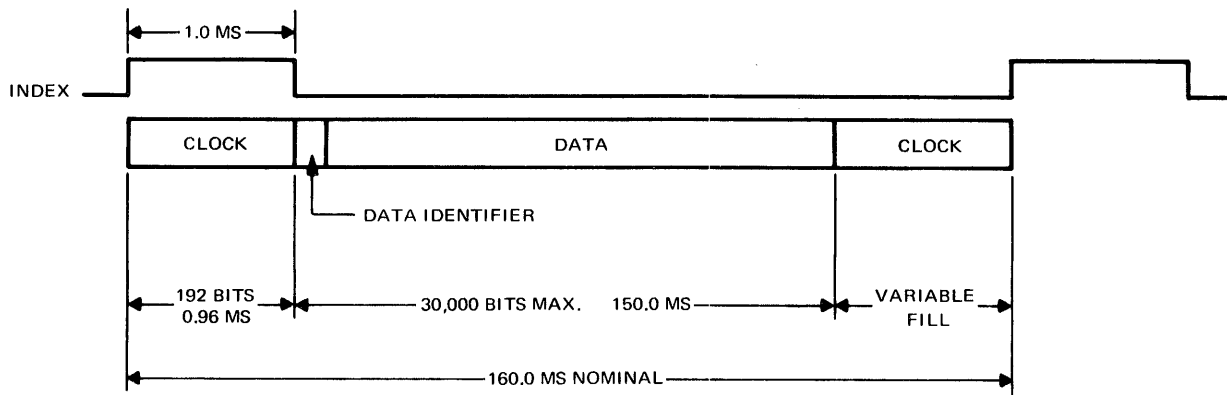

Figure 9. Index Recording Format

00570

To generate the index format, the user would use the same procedure as discussed earlier (Figure 8) for sector recording. The length of the data record is the only difference between index and sector format.

Installation

ENVIRONMENT

The file is designed to operate within the temperature and humidity ranges specified in Table 2.

TABLE 2. TEMPERATURE-HUMIDITY RANGES FOR FILE AND DISC CARTRIDGE

	OPERATING	NON-OPERATING
Temperature	60° F to 100° F	40° F to 120° F
Relative Humidity	20% to 80%	90% max
Wet Bulb Temperature (max)	78° F	
Heat Generated (max)	346 BTU/hr	

The disc must be used within the operating temperature and humidification conditions specified above to ensure interchangeability. Also, exposure of the disc to magnetic fields greater than 50 oersteds can cause loss of data.

Performance of the 650 can be seriously degraded by improper environment. Dust and other airborne contaminants are a major threat to the operating life of the recording components and the actuator. The file utilizes a vertical disc drive arrangement to minimize particle settling at the head/disc area. Environmental protection similar to that used for magnetic tape and removable disc pack installations should be observed.

CONNECTORS AND CABLES

All internal cables are factory installed prior to shipment. Recommended connectors and cable lengths which must be supplied by the user are shown in Table 3. The male sides of required interface connectors are mounted to the 650 frame.

TABLE 3. CONNECTORS SUPPLIED BY USER

Part	Part Number		Notes	Propose	Recommended Cable Length
	Memorex	Manufacturer			
Block, 42 position	158570	Amp 202516-1	Single signal wire +24V or multiple crimps Outside thread Inside thread Outside thread Inside thread	Input DC Power, Control signals, and data signals	15 feet Maximum including harness wiring in using system, coax should be 93 ohms for 3 data lines.
Socket, 20-22 AWG	150246	Amp 66331-6			
Socket, 16-18 AWG	150290	Amp 66100-6			
Coax, socket	158572	Amp 1-201146-2			
Jackscrew, short	150725	Amp 201388-2			
Jackscrew, short	150540	Amp 201389-2			
Jackscrew, long	150724	Amp 200871-1			
Jackscrew, long	150546	Amp 200867-1			
Hood, short	-----	Amp 201182-2			
Hood, long	-----	Amp 201847-1			
Connector Housing	150265	Amp 1-480303-0	center socket is ground	AC Power	Restricted only by approved wiring codes and Underwriter Laboratories
Socket	150203	Amp 61117-1			

Keying of the signal connector is accomplished by the jackscrew arrangement shown in Figure 10.

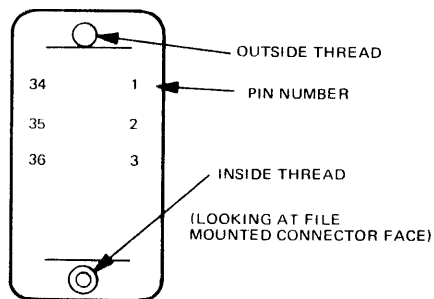

Figure 10. Signal Connector Keying

00571

MOUNTING DIMENSIONS

The mounting dimensions for the 650 are shown in Figure 11.

WEIGHT

The weight of the 650 without accessories is approximately 20 pounds.

OPTIONAL MOUNTING DIMENSIONS (CHASSIS SLIDES)

The mounting dimensions for the 650 with optional chassis slides are shown in Figure 12.

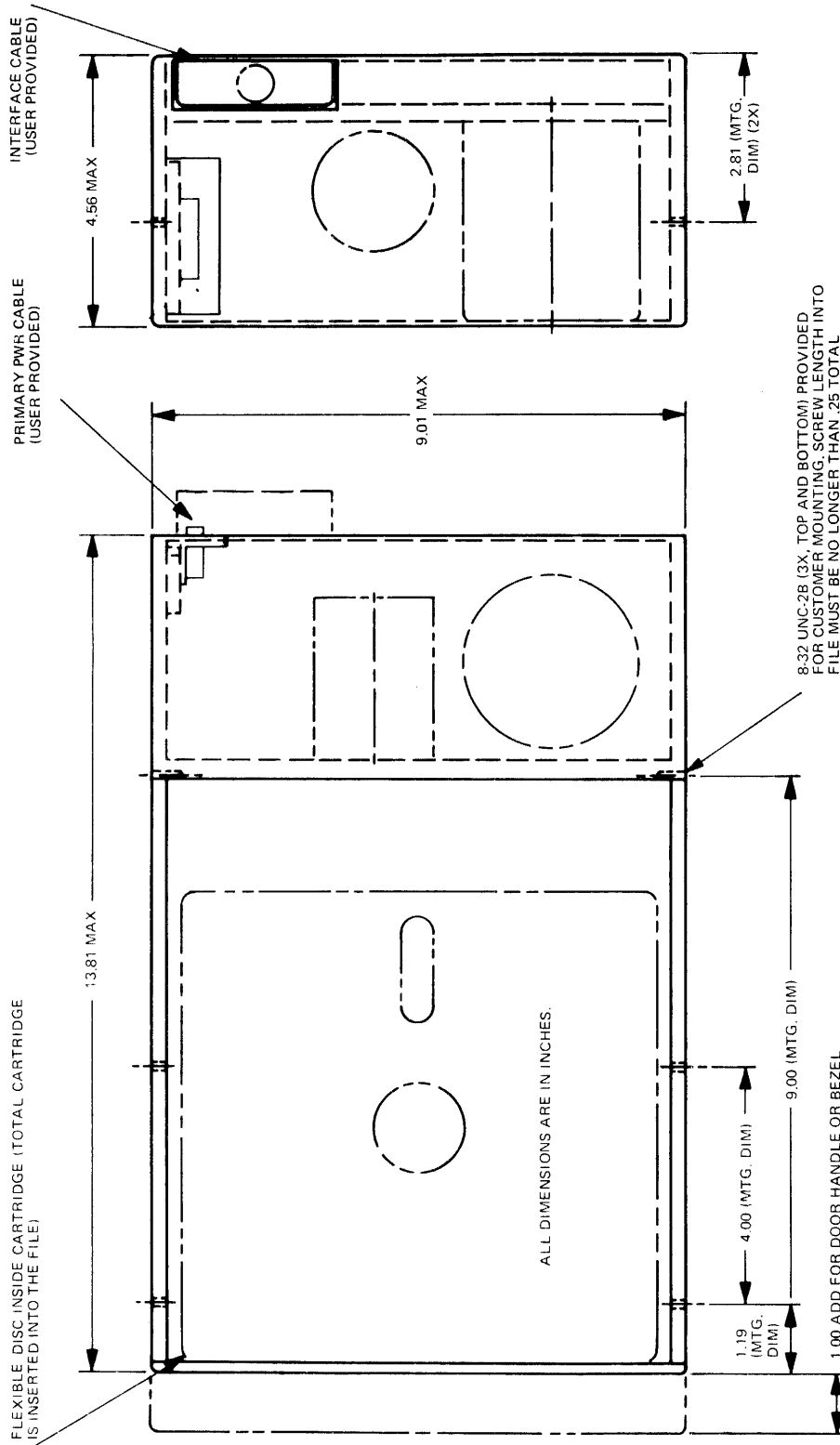

00572

Figure 11. Flexible Disc Mounting Dimensions

Interface Description

GENERAL

The interface requirements can be divided into three categories: Control, Data, and Power. The following paragraphs describe the requirements with relationship to connector, polarity, load level, and pulse width. Figure 13 is the wiring diagram of the 650 with signal names, pin numbers, and connectors. The 650 requires only two cables, power and control-data. The twisted-pair lines are physically four wires and are wired as illustrated below.

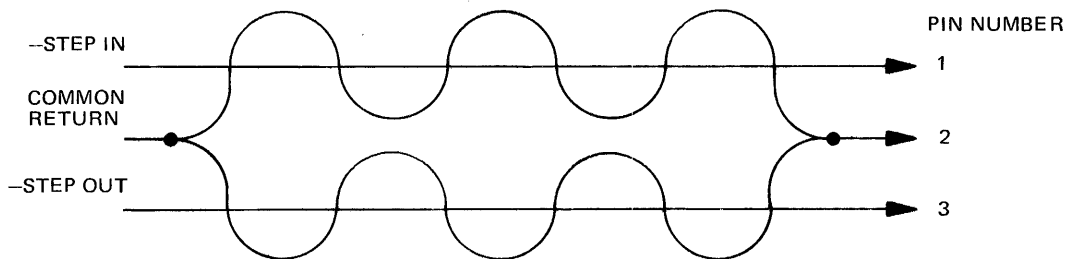

CONTROL

The control signals are divided into two types: input and output. The input signals are provided by the host system and output signals are from the 650. The FUNCTIONAL CHARACTERISTICS section previously described these signals. Polarity for logic signals indicates "negative going" for negative and "positive going" for positive pulses.

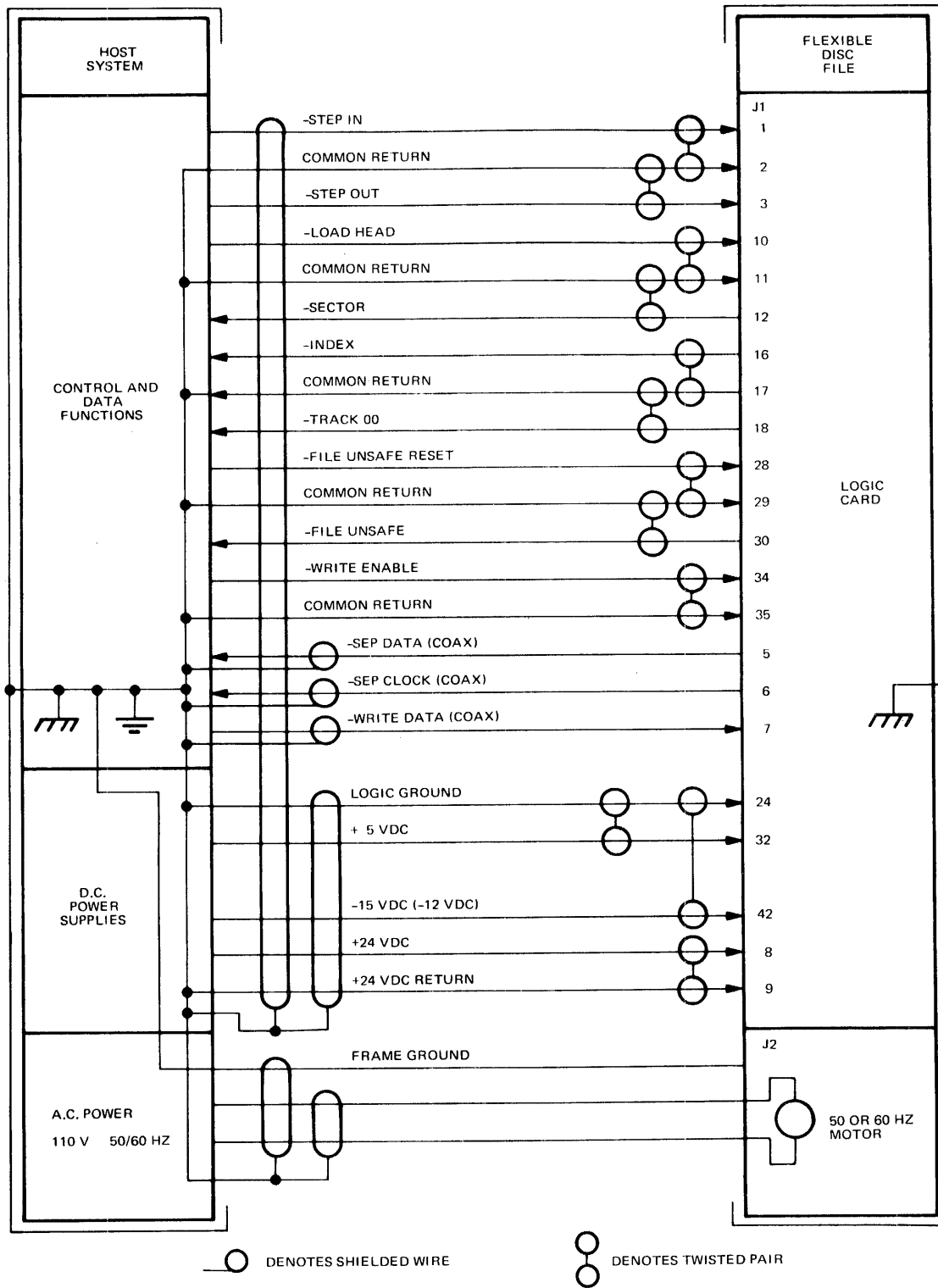

Figure 13. Flexible Disc Wiring Diagram

00574

Input

Table 4 lists the input signals.

TABLE 4. INPUT CONTROL SIGNALS

INPUT SIGNAL DESIGNATION	CONNECTOR AND PIN	POLARITY	PULSE WIDTH	COMMENTS
-STEP IN	J1-1	Negative	10 μ s to 10 ms	Track Positioning
COMMON RETURN	J1-2	Negative Return		
-STEP OUT	J1-3	Negative	10 μ s to 10 ms	
-LOAD HEAD	J1-10	Negative	Level	Enables head load solenoid
COMMON RETURN	J1-11	Negative Return		
-FILE UNSAFE RESET	J1-28	Negative	Level	Reset for 650 control logic
COMMON RETURN	J1-29	Negative Return		
-WRITE ENABLE	J1-34	Negative	Level	Enabling function for writing data
COMMON RETURN	J1-35	Negative Return		

Output

Table 5 lists the output signals

TABLE 5. OUTPUT CONTROL SIGNALS

OUTPUT SIGNAL DESIGNATION	CONNECTOR AND PIN	POLARITY	PULSE WIDTH	COMMENTS
-SECTOR	J1-12	Negative	1ms	Indicates location on disc
COMMON RETURN	J1-11	Negative Return		
-INDEX	J1-16	Negative	1ms	Indicates location on disc
COMMON RETURN	J1-17	Negative Return		
-TRACK 00	J1-18	Negative	Level	Indicates when head is positioned on Track 00
COMMON RETURN	J1-17	Negative Return		
-FILE UNSAFE	J1-30	Negative	Level	Safety sensing signal indicating file malfunction
COMMON RETURN	J1-29	Negative Return		

DATA

The data input and output signals are listed in Table 6.

TABLE 6. DATA SIGNAL INTERFACE

DATA SIGNAL DESIGNATION	CONNECTOR AND PIN	POLARITY	PULSE WIDTH	COMMENTS
-SEP DATA	J1-5	Negative	0.25 μ Sec	Output data from disc
-SEP CLOCK	J1-6	Negative	0.25 μ Sec	Output clock from disc
-WRITE DATA	J1-7	Negative	0.25 μ Sec	Input data and clock signal to file

POWER

The power inputs required are listed in Table 7.

TABLE 7. POWER PARTITIONING

POWER SIGNAL DESIGNATION	CONNECTOR AND PIN	POLARITY	DRIVE CHARACTERISTIC	PULSE WIDTH	COMMENTS
LOGIC GROUND	J1-24	Logic ground	Logic ground	Logic ground	DC power supply ground
+5VDC	J1-32	Positive	+5 ± 0.10VDC @ 0.6A 50 mv ripple	Power level	Logic Power supply
-15VDC	J1-42	Negative	-15 ± 0.30VDC @ 0.12A 50 mv ripple	Power level	DC power supply for read/write amplifiers
(-12VDC)*			-12 ± 0.25VDC @ 0.12A 50 mv ripple		
+24VDC	J1-8	Positive	+22 ± 1VDC @ 2.0A 100 mv ripple	Power level	DC power supply for head positioning motor and head load solenoid
+24VDC RETURN	J1-9	DC Power ground	DC power ground	DC power ground	+24VDC power ground
110 VAC 50/60Hz	J2 Three terminal socket	Line AC	110 ± 10% VAC @ 0.75A 50/60 ± 0.5Hz single phase	Line AC	Must be provided from a branch circuit protected at no more than 20 amperes.
FRAME GROUND	J2 Center Socket	Frame ground	Frame ground	Frame ground	Center socket of 3-wire AC socket

*May be used in lieu of -15 Volts with no modifications to the file or cables.

INTERFACE CIRCUITRY

Memorex recommends that the host system use the following interface circuitry. These circuits are used for Control and Data input/output functions. Memorex uses transistor-transistor logic (TTL); therefore, logic symbols used in the interface circuitry have TTL characteristics. In all cases:

High = False = Logical "0"
 Low = True = Logical "1"

Control Interface Circuitry

All transmitted signals to the file should originate from open collector drivers capable of current sinking 20 milliamps. Conversely, the user's receiver should be a current source of 10 milliamps. Figure 14 shows the recommended circuits for the line driver and line receiver. Line receiver is a circuit which receives signals from the 650 and a line driver transmits signals to the 650. The line receiver should detect a true signal no higher than +1.5 volts, and a false signal no lower than +2.5 volts.

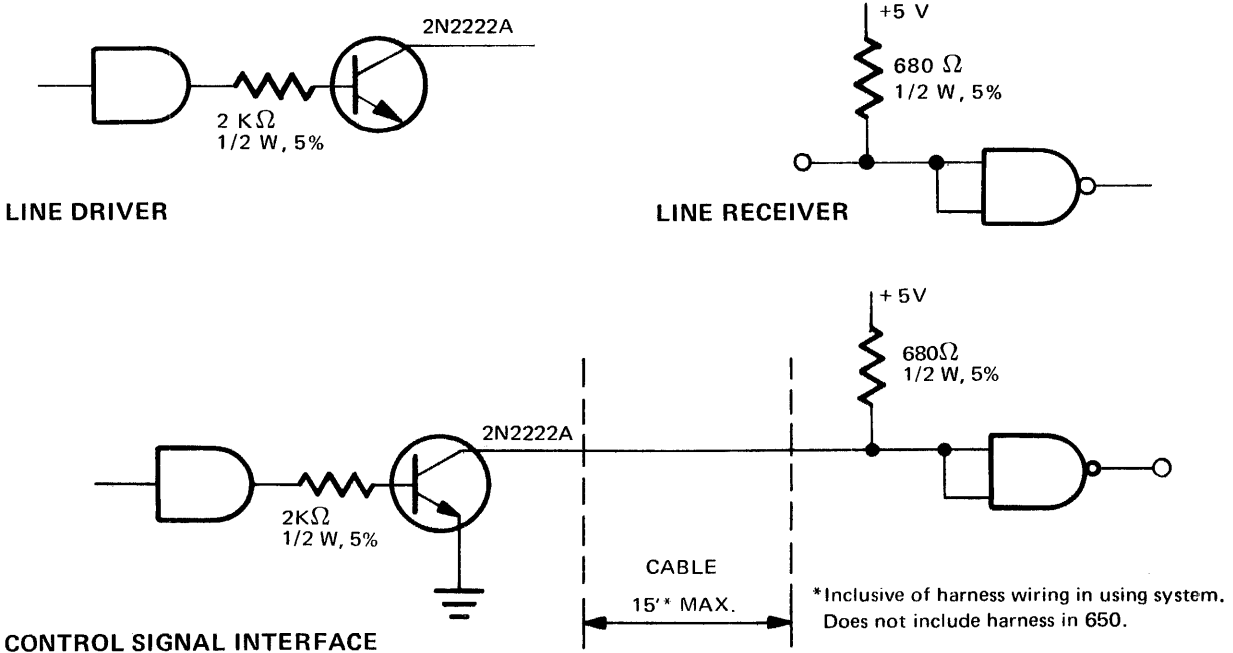
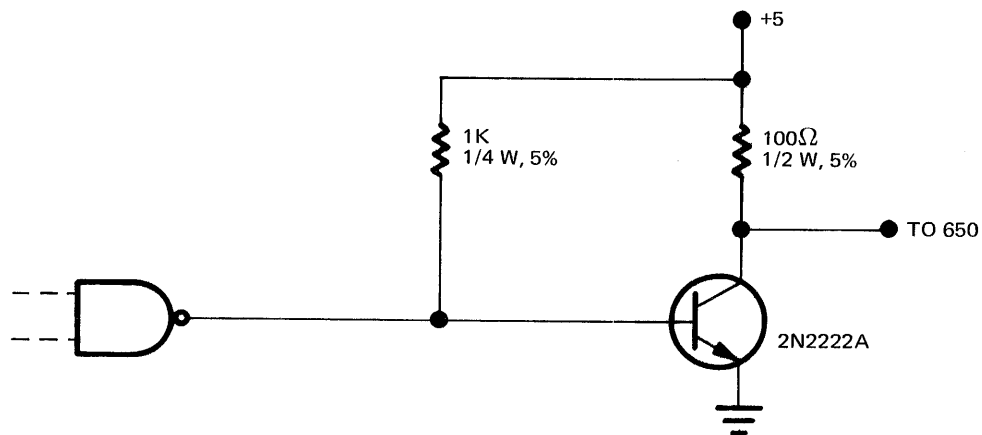
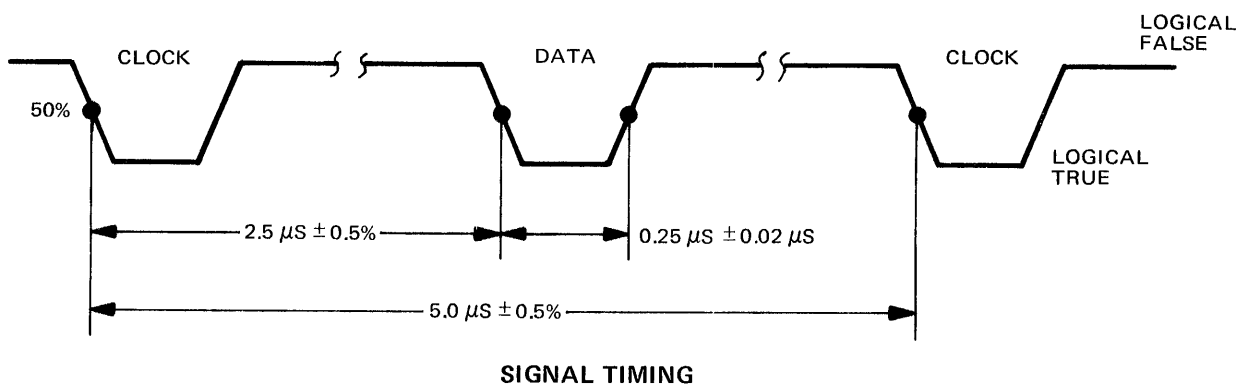

Figure 14. Control Line Driver and Line Receiver

00575

Data Interface Circuitry

The recommended WRITE DATA signal and circuit are shown in Figure 15. The composite signal was described earlier in the FUNCTIONAL CHARACTERISTICS section.



WRITE DATA DRIVER

Figure 15. Write Data Signal and Driver

00576

The recommended SEP DATA and SEP CLOCK signals and circuits are shown in Figure 16. All time measurements are made at the output of the read channel PCB of the 650. Maximum sink current during true time is 55 milliamps. The source current is zero.

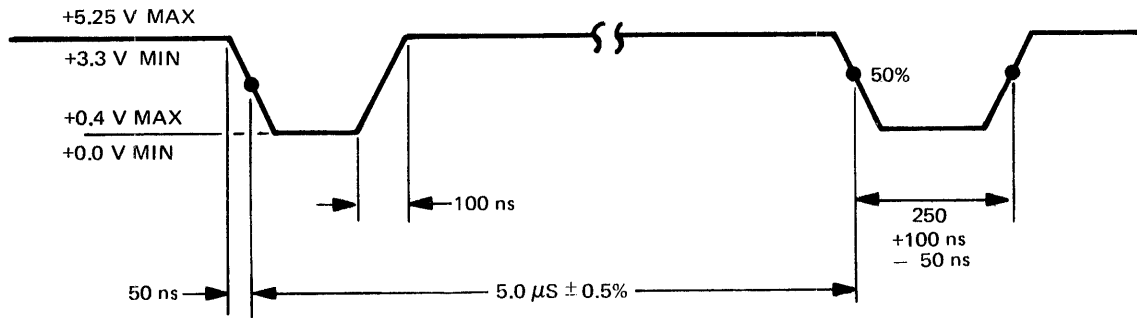

SEP DATA AND SEP CLOCK SIGNALS

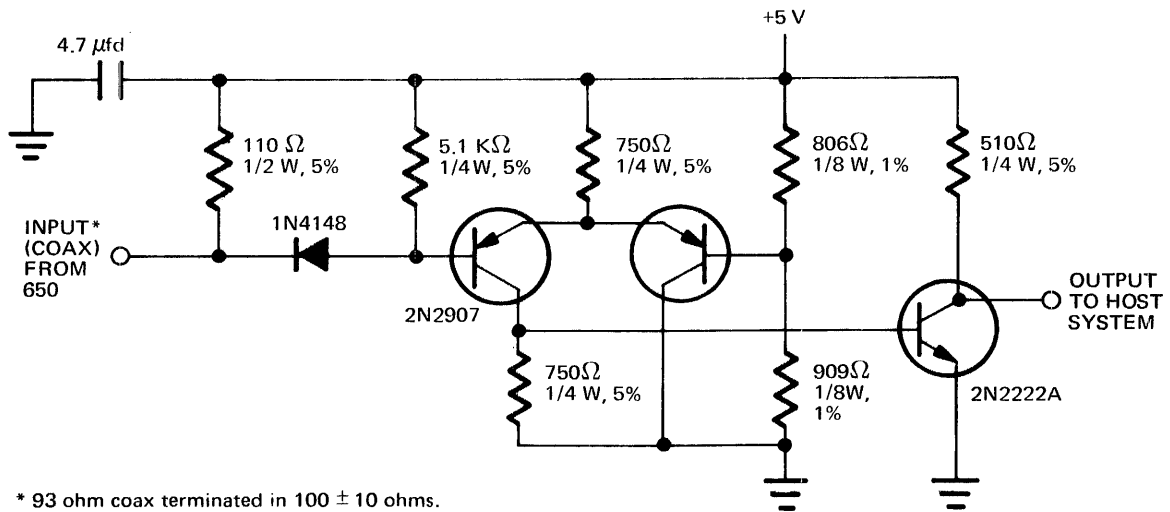

SEP DATA AND SEP CLOCK RECEIVERS

Figure 16. Separated (SEP) Data and Clock Signals and Receivers

00577

Operating Procedures

Operation of the 650 is fully automated requiring no operator intervention during normal operation. The disc cartridge should be handled carefully when being inserted or removed from the 650. The following paragraphs give procedures necessary for insertion of the disc cartridge into the 650 and for cartridge handling. Also included are some suggested software procedures for handling error conditions which might occur during writing or reading operations.

CARTRIDGE LOADING AND HANDLING

The cartridge consists of the flexible disc encased in a plastic jacket. Wipe cushions are bonded to the inside of the jacket. The disc is housed and rotates between these cushions during normal operation. Figure 17 shows how the cartridge is inserted in the cartridge guide. This is accomplished by merely opening the door, inserting the cartridge into the cartridge guide, and closing the door.

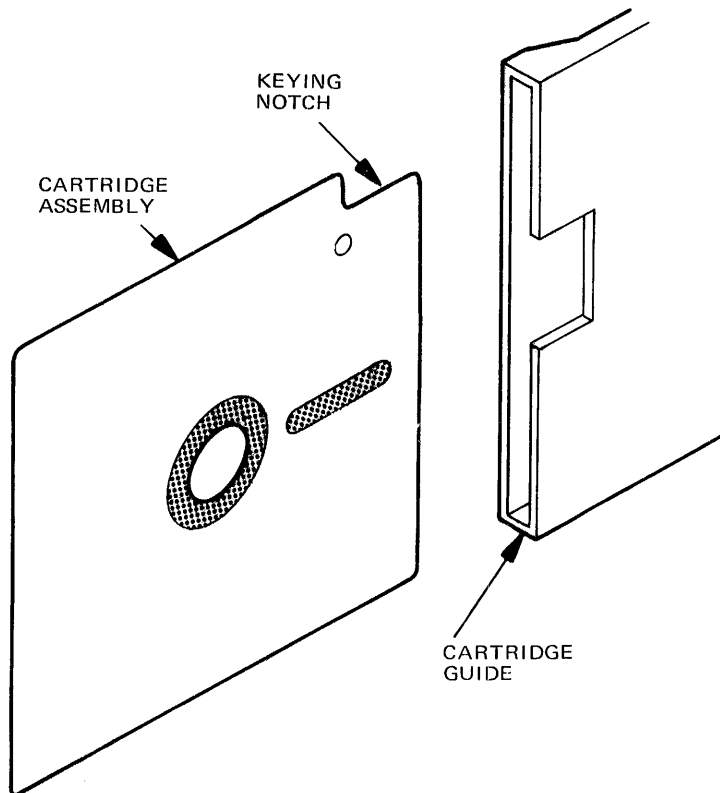

Figure 17. Cartridge Loading

00578

When removed from the 650, the cartridge is stored in a plastic coated envelope. To protect the cartridge, the same care and handling procedures specified for computer magnetic tape apply. These precautionary procedures are as follows:

1. Return the cartridge to its storage envelope whenever it is removed from file.
2. Store cartridges vertically.
3. Keep cartridges away from magnetic fields and from ferromagnetic materials which might become magnetized. Strong magnetic fields can distort recorded data on the disc.
4. Replace storage envelopes when they become worn, cracked, or distorted. Envelopes are designed to protect the disc.
5. Do not write on the plastic cartridge with a lead pencil or ball-point pen. Writing pressure may damage the disc.
6. Do not smoke while handling cartridges. Heat and contamination from a carelessly dropped ash can damage the disc.
7. Do not expose cartridges to heat or sunlight. The read/write head on the 650 cannot properly track a warped disc.
8. Do not touch or attempt to clean the disc surface. Abrasions may cause loss of stored data.

ERROR DETECTION AND CORRECTION

Write Error

If an error occurs during a write operation, it will be detected on the next revolution by doing a read operation, commonly called a "write check". To correct the error, another write and write check operation must be done. If the write operation is not successful after 10 attempts have

been made, error correction should be attempted on another track. If the error still persists, the disc should be considered defective and discarded.

Read Error

Most errors that occur will be "soft" errors; that is, by performing an error recovery procedure the data will be recovered.

Soft errors are usually caused by:

1. Airborne contaminants that pass between the read/write head and the disc. These contaminants will generally be removed by the cartridge self-cleaning wiper.
2. Random electrical noise which usually lasts for a few μsec .
3. Small defects in the written data and/or track not detected during the write operation which may cause a soft error during a read.

The following procedures are recommended to recover from the above mentioned soft errors:

1. Reread the track 10 times or until such time as the data is recovered.
2. If data is not recovered after using step 1, access the head to the adjacent track in the same direction previously moved, then return to the desired track (i.e., if at track 20, then moved to track 30 where an error occurs, move to track 31, and return to track 30.)
3. Repeat Step 1.
4. If data is not recovered, the error is not recoverable.