

NEW DEVOLATILIZATION PROCESS FOR THERMOSENSITIVE AND HIGHLY VISCOUS POLYMERS IN HIGH VOLUME KNEADER REACTORS

*Dr. Daniel U. Witte
LIST AG, Arisdorf, Switzerland*

Abstract

The achievable final volatile content within kneader devolatilization processes is highly dependent on the final melt temperature. For thermosensitive polymers the state of the art process performs poorly. The amount of dissipated energy leads to a heat up of the polymer, limiting the maximal kneader shaft speed and therefore volatile removal rate. This new process uses a suitable additional volatile compound to cool off the dissipated energy by evaporation using the off gas to strip and boost the mass transfer coefficient. A complex multi-parameter study is presented, to predict performance of industrial equipment from pilot scale data.

Introduction

A previous study of mass transport in kneader reactors for devolatilization [1] has shown that achieved mass transfer rates highly depend on product temperature for three reasons:

- From thermodynamics of polymer / solvent mixtures, it is known that at low temperatures, the achievable final volatile content would be a couple thousand ppm of hexane, toluene or other similar solvents.
- The mass transfer coefficient highly depends on temperature.
- During the kneading process mechanical heat is dissipated into the polymer. This heat leads to an increased product temperature over the length of the kneader process chamber unless it is removed by contact cooling. Or, the ability of the kneader to remove heat by contact is limited especially at higher polymer rates and decreases with equipment size due to the lower heat exchange area to reactor volume ratio. The amount of dissipated mechanical heat depends on shaft torque and speed. The shaft torque is directly related to the available mass exchange surface of the product. The shaft speed determines the surface renewal rate. The higher the possible product end temperature, the faster the kneader can turn leading to more surface renewal and therefore a more efficient solvent removal. This limits particularly the

processing of highly viscous melts since viscosity, fill, and shaft torque are interconnected in a kneader.

A couple of years ago, a new evaporator technology has been introduced [2] specifically targeting thermosensitive and highly viscous polymer solutions, aiming the thermal separation of the solvent from the polymer cement stream (polymer cement is defined as solution of polymer dissolved in a solvent or a solvent dissolved in a polymer stream. This new technology provides a constant cement flow of about 5 to 10 % remaining volatile content at around 100 °C. In order to remove the remaining volatile content, a further finishing step is necessary that so far did not exist. The conventional technology to treat such polymer cement streams is steam stripping avoiding the handling of highly viscous melts, but requiring large amounts of steam.

The goal of this study was to investigate if a liquid additive applied to the finisher stream would allow for improved temperature control of the polymer stream within the kneader. The additive would evaporate and enrich the gas room around the bulk polymer thus providing a stripping effect. A pre-study had shown that both of these effects would be insufficient to boost the capacity of the kneader to an economically feasible process solution. We therefore hoped that the mass transfer coefficient would be positively affected as well. A further goal of this study was to get a first approximation of that mass transfer coefficient and to provide a reliable method to scale up this process to industrial size.

Experimental

A schematic view of the internal of the kneader equipment is given on Figure 1. The kneader provides a large interface between the polymer melt and the surrounding gas phase. This means that there is plenty of opportunity to degas and mix liquid additives into the melt. The tests were performed on two separate set ups of different sizes 7, 30 and 170 L respectively to better quantify the effect of equipment size on devolatilization efficiency. The set up is shown on Figure 2. The liquid polymer cement solution of about 85% volatile content was pre-concentrated in a kneader evaporator to 5% final volatile content before entering the High Volume Finishing Kneader. Water was added by means of metering pumps separately at three locations over the length section of the kneader process chamber. By the

nature of the high volume kneader design, the water hits the hot polymer at the same pressure as is applied throughout the process chamber. The polymer stream exited the kneader by means of a twin shaft screw. The volatiles were condensed and off-gases evacuated into a vent. Optionally, off-gases would be compressed by a vacuum pump allowing the test of various vacuum levels within the kneader process chamber.

The polymer we treated was High Cis Polybutadiene Rubber (BR), Mooney 20, but also some Styrene Polybutadiene Rubber (SBR) grades. The volatile (solvent) was toluene or hexane.

Polymer samples were taken at the exit of the discharge screw. Samples were analyzed using head space GC. The kneader was adjusted to keep a constant shaft torque during one campaign and emptied out after each campaign to get the corresponding fill. We also measured Mooney loss and color.

We adjusted different parameters such as vacuum level, shaft speed, polymer rate and polymer temperature. The amount of water was adjusted to keep the desired polymer temperature constant. So, there is no independent determination of water feed rate possible.

In order to assess results, a process model had to be established. There are multiple, fluctuating parameters such as temperature, gas flow composition, solvent and additive content, which change over the kneader length and can influence the final volatile content. Considering plug flow behavior, the differential heat balance at the position x fraction of the reactor length is:

$$\frac{dU_x}{dt} = 0 = \dot{H}_x - \dot{H}_{x+dx} + d\dot{Q}_{contact,x} + d\dot{Q}_{diss,x} \quad (1)$$

whereas the enthalpy difference is the following:

$$\dot{H}_x - \dot{H}_{x+dx} = - \left(\dot{m}_{pol,x} c_{p,pol,x} + \sum_{i=1}^{n_{liq}} \dot{m}_{liq,i,x} c_{p,i,liq,x} \right) \frac{\partial T_x}{\partial x} dx \quad (2)$$

$$+ \sum_{i=1}^{n_{liq}} \Delta h_{v,i,x} \frac{\partial \dot{m}_{liq,i,x}}{\partial x} dx$$

Since the polymer stream is not volatile, we can substitute it as follows:

$$\dot{m}_{liq,i,x} = \dot{m}_{pol,x} \frac{w_i}{1 - \sum_{i=1}^{n_{liq}} w_i} \quad (3)$$

The water is considered not being mixed in at a spot (the feed spreads out over a certain kneader length), but is considered evenly spread over a specified length fraction. A fraction of it is mixed into the bulk cement stream:

$$\frac{\partial \dot{m}_{liq,i,x}}{\partial x} = \frac{\partial \dot{m}_{trans,i,x}}{\partial x} + \Phi \frac{\partial \dot{m}_{add,i,x}}{\partial x} \quad (4)$$

For the volatile that has to be removed, the adder is 0. Likewise, we can make a mass balance over the gas stream:

$$\frac{\partial \dot{m}_{gas,i,x}}{\partial x} = - \frac{\partial \dot{m}_{trans,i,x}}{\partial x} + (1 - \Phi) \frac{\partial \dot{m}_{add,i,x}}{\partial x} \quad (5)$$

Note that the gas room in the kneader is interconnected. The off gas flows over the product until a vapor disengagement dome, which was placed at different length positions of the process chamber. From the calculated gaseous mass stream, its composition can be calculated and therefore the stripping effect determined.

The transferred volatile can be calculated using a mass transfer law:

$$\frac{\partial \dot{m}_{trans,i,x}}{\partial x} = -2 \sqrt{\frac{D_{i,eff}}{\pi t_{contact}}} A_i \rho_{cement} (w_i - w_{i,eq}) \quad (6)$$

This is the penetration theory described previously [1]. The mass balance is shown schematically on Figure 3.

The contact heat has been calculated according to:

$$\dot{Q}_{contact,x} = \alpha A_H (T_H - T) \quad (7)$$

The heat transfer coefficient was adjusted in order to fit the model product temperatures with the measured product temperatures. The mechanical heat input was calculated using a proprietary calculation method for High Volume Kneader Reactors [3]. Both mechanical heat input and polymer to gas interphase depend on the local fill the kneader. A model to describe axial conveying was used that has been described previously [4].

The equilibrium concentration was calculated according to the Flory-Huggins Theory:

$$\frac{P_i}{P_0} = e^{\ln(\phi_i) + (1-\phi_i) + \chi(1-\phi_i)^2} \quad (8)$$

For toluene / BR-mixtures, χ number of 0.38 was used [5]. For water, we used the same number, since we did not find published data. Since the prime focus of this study was to determine organic volatile content, and the water content in the final product does agree reasonably well with calculated data, we think a better correlation will not be of much use for the purpose of this study. To determine the effective diffusion coefficient, we used a previously published approach [1]. We investigated the two boundary assumptions of either no or complete interaction of the two volatile compounds on mass transfer coefficient.

Results and discussion

Visually, we could observe through a sight glass that the rubber was white when entering the kneader. This confirms that bubble kinetics is driving the devolatilization. It appears that the heat transfer coefficient is difficult to accurately calculate giving that the difference between jacket and product temperature was small. A simulated temperature profile is shown on Figure 4. There were only three product temperature measurements over the reactor length. The projected temperature fluctuations exceed what possibly could be measured. The rubber was stated to be temperature stable up to around 130°C. None of the samples showed thermal degradation and no Mooney increase was observed.

Figure 5 shows a calculated solvent content profile. Since measured final volatile contents were very low, the model is quite difficult to calibrate properly. The results can be easily off by one magnitude. Still, this is expected because of the complexity of the mass transport situation in the kneader. Pilot size kneaders have specific mass transfer areas, which are 5 to 10 times higher than industrial scale kneaders. For industrial kneaders, we project that final volatile compound residual levels will be higher than those measured on pilot scale kneaders. This means that the calculation should show good agreement both for high and low volatile levels. This seems difficult to achieve and we probably need more data to better quantify the model assumptions.

The operation range of this kneader application seems narrow. The rubber tends to turn over into a free flowing granular product at higher shaft speed and low fill. Since shaft speed is key to get good devolatilization especially for larger kneader units, it is important to keep the fill above a specified value of about 30 to 40 % depending on the rubber grade in order to keep the product pasty at all time. Once the product is granular, shaft torque decreases dramatically and no mixing within the rubber particles takes place limiting greatly the amount of liquid stripping agent that can be incorporated into the rubber. No surface renewal takes place within a granular bed and the voidage between the rubber particles leads to much lower possible product hold up within the process chamber. Since the product fill profile over the kneader length depends on shaft speed, the conveying characteristics of the kneader have to be designed carefully to get a horizontal fill profile at design rate and shaft speed. The simulation predicted that the pilot finisher would convey the material too fast and indeed we could observe granular product in the feed zone of the kneader.

For the larger pilot kneader (160 L), we still observed very low volatile levels around 10 ppm. This is an encouraging result, but shows that confirming the model

for those measured values is difficult. There is a lower tendency to form granular material for this kneader size. Still, conveying was too strong to get an equilibrated fill profile at higher shaft speed and a tendency to form granular material in the feed zone could be observed. We were limited to test a residence time range between 30 and 45 min since the evaporator did not allow exceeding this rate. Still, we managed to process up to 65 kg per hr of rubber of homogenous quality without Mooney increase. Another important finding was that the torque level on the drive shaft of the kneader was high, up to 100 Nm/L of reactor volume. It seems difficult to lower this torque significantly. This means that in order the process to be economical, the residence time must be minimal and a very sturdy kneader design is required.

For the medium sized pilot of 25 L, we managed to lower the residence time to 20 min. Still, we got low final organic volatile contents. The process was less stable and we observed 1 to 2 % of water in the discharged polymer at high rates. Results are summarized on Table 1.

Using the above described model to predict the performance of an industrial scale kneader, we predict that we would achieve a final volatile level of 300 ppm at a shaft speed around 40 to 60 RPM. This is a higher shaft speed as we observed during the tests. The higher shaft speed is required to compensate for the lower surface renewal to volume ratio of the larger sized equipment. The projected energy consumption is roughly 1 to 2 MJ/kg produced rubber. The choice of the transport angle will be even more critical to avoid a low fill situation in a length section of the kneader.

Summary

A new process of removing organic volatiles from highly viscous polymer melts in kneader equipment is described. The process allows processing of these polymer streams at much higher rate and reduced final organic volatile levels than the state-of-the-art technology. A model was established to predict performance of industrial kneader equipment using this process type. The new process appears to be scaleable to typical industrial size capacities for BR rubber.

Nomenclature

A	surface	[m ²]
c _p	specific enthalpy	[J/kg/K]
D	diffusion coefficient	[m ² /s]
Δh _v	enthalpy of evaporation	[J/kg]
\dot{H}	enthalpy stream	[W]

•		
m	mass stream	[kg/s]
n	number of	
p	(partial) operating pressure	[Pa]
p_0	vapor pressure	[Pa]
•		
\dot{Q}	added heat stream	[W]
T	(product) temperature	[K]
T	temperature	[K]
t	time, duration	[s]
U	inner energy	[J]
w	mass fraction	[kg/kg]
w	mass part	[kg/kg]
x	reactor length position (between 0 and 1)	[-]

greek:

α	heat transfer coefficient	[W/m ² /K]
ϕ	volumetric part	[m ³ /m ³]
Φ	mass fraction, which is compounded in of additive	[kg/kg]
χ	Flory-Huggins interaction parameter	[-]
ρ	density	[kg/m ³]

indices:

add	added liquid volatile and liquid volatile components
cement	mixture of non volatile polymer
contact	contact
diss	dissipated
eff	effective
eq	at equilibrium
gas	of gas stream
H	of heat exchange area
I	of interphase
i	one of the liquid volatile component interface boundary
liq	of liquid (dissolved) volatile phase
pol	of polymer (non volatile) phase
trans	transferred through liquid to gas
x	at reactor length position x

3. D.Jermann, T.Lukic "Newton-Reynoldszahl für LIST-Kneter", Diploma work, Fachhochschule beider Basel (FHBB), 2003
4. Daniel Witte, "Axial transport in kneader reactors", Antec (2007)
5. Hwang, W.-G., Wei, K.-H, Chang-Mou Wu, C.-M., "Synergistic effect of compatibilizer in organo-modified layered silicate reinforced butadiene rubber nanocomposites",

Key Words

Devolatilization, stripping, kneader, finishing, diffusion, mass transfer

References

1. Daniel Witte, "Prediction of mass transport of solvent / polymer systems in high volume kneader reactors at finite solvent concentrations", Antec (2009)
2. Safrit, B., Diener, A., "Kneader Technology for the Direct Devolatilization of Temperature Sensitive Elastomers", Antec (2008)

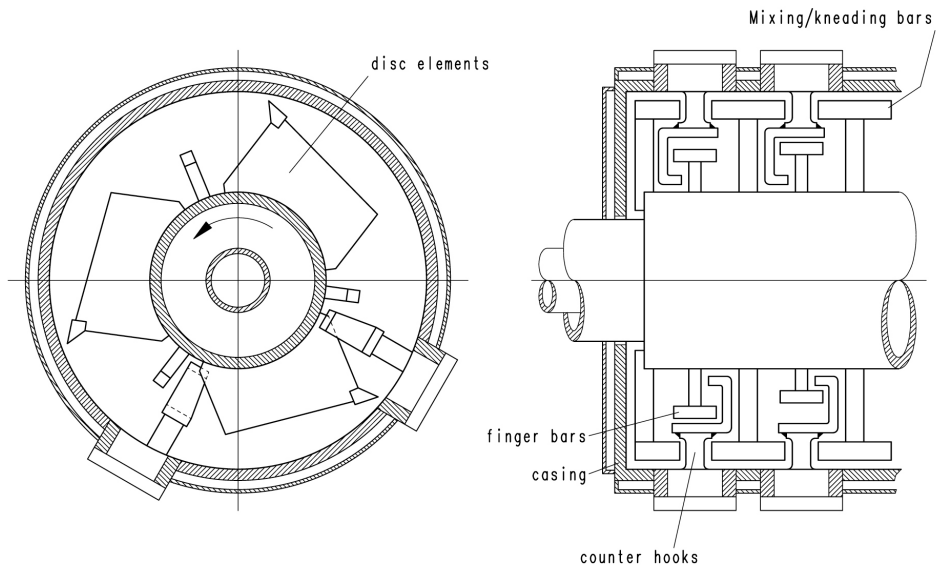

Figure 1: Single shaft kneader

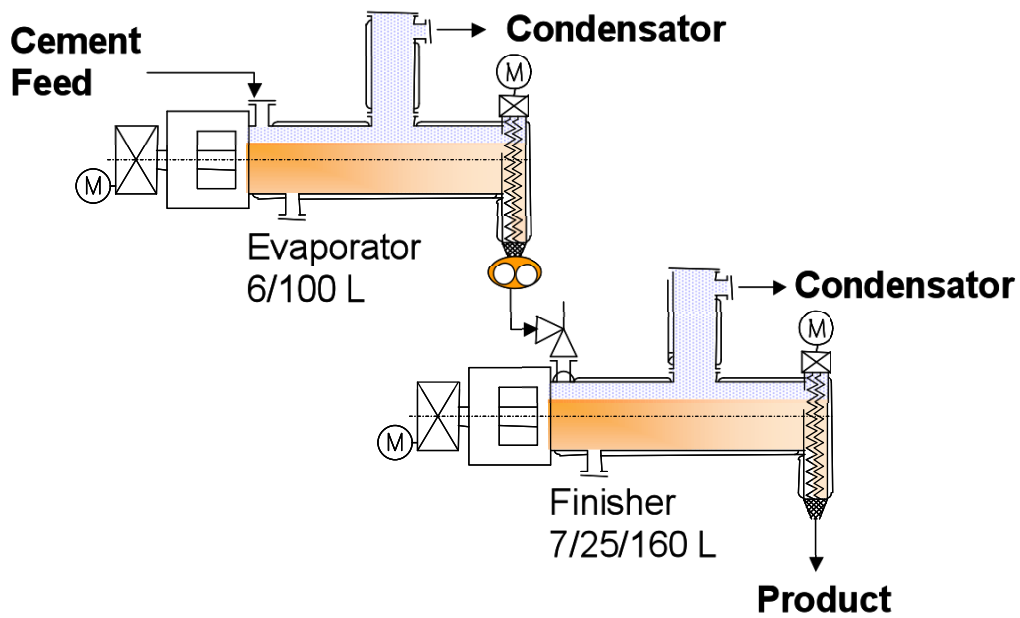

Figure 2: Test set up

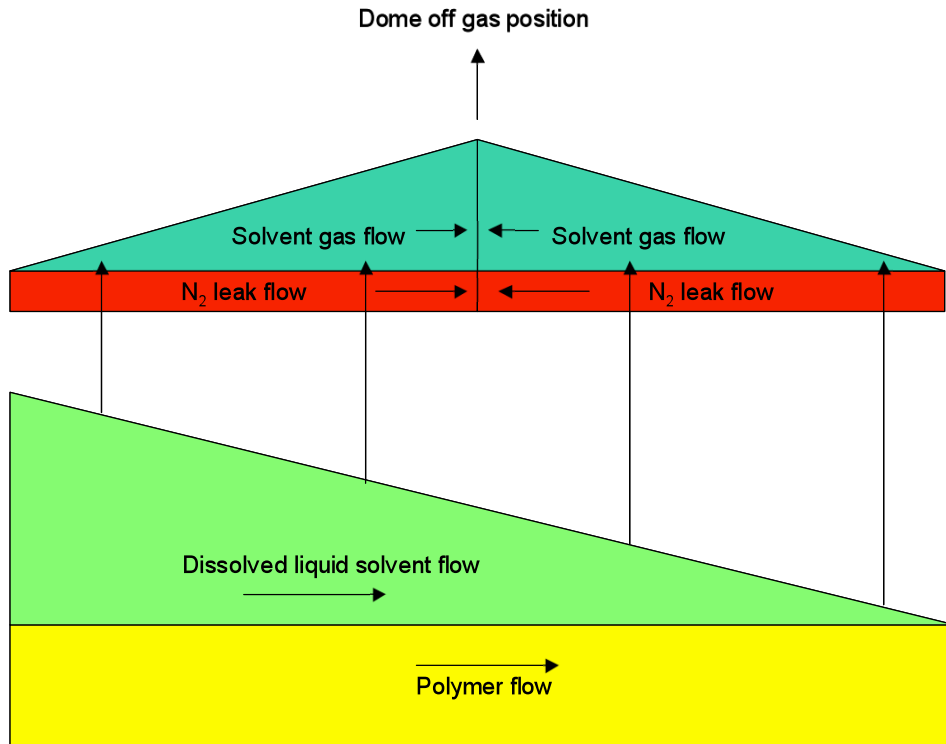

Figure 3: Schematic mass balance in devolatilization kneader

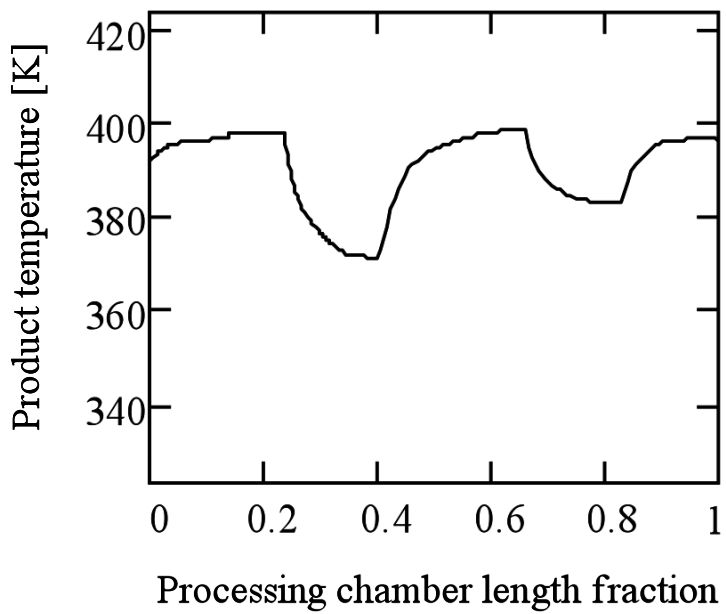

Figure 4: Typical simulated temperature profile in kneader equipment

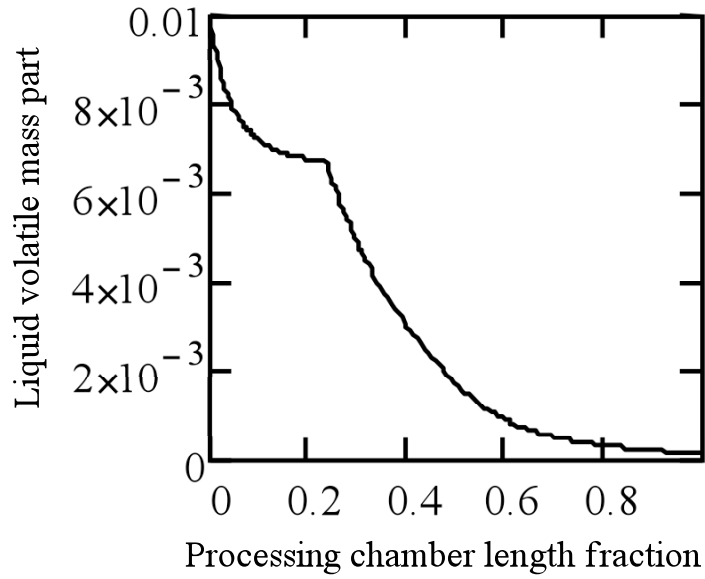

Figure 5: Liquid volatile mass part on kneader length fraction

Kneader finisher size	Rubber Capacity	Final VOC	Total volatiles
7 liter	2.5 kg/hr	< 10 ppm	5000 ppm
30 liter	30 kg/hr	< 50 ppm	5000 ppm
100 liter	50 kg/hr	< 50 ppm	5000 ppm
200 liter	50 kg/hr	< 15 ppm	5000 ppm

Table 1: Results of continuous test run