



U.S. Department
of Transportation

**Federal Highway
Administration**

Publication No. FHWA NHI 01-003
March 2001

Hydraulic Engineering Circular No. 23

Bridge Scour And Stream Instability Countermeasures

Experience, Selection, and Design Guidance

Second Edition



NATIONAL HIGHWAY INSTITUTE

Training Solutions for Transportation Excellence

1. Report No. FHWA NHI 01-003 HEC-23	2. Government Accession No.	3. Recipient's Catalog No.	
4. Title and Subtitle BRIDGE SCOUR AND STREAM INSTABILITY COUNTERMEASURES Experience, Selection and Design Guidance Second Edition		5. Report Date March 2001	
7. Author(s) P.F. Lagasse, L.W. Zevenbergen, J.D. Schall, P.E. Clopper		6. Performing Organization Code	
9. Performing Organization Name and Address Ayres Associates 3665 JFK Parkway Building 2, Suite 200 Fort Collins, Colorado 80525		8. Performing Organization Report No.	
12. Sponsoring Agency Name and Address Office of Bridge Technology National Highway Institute FHWA, Room 3203 4600 North Fairfax Dr., Suite 800 400 Seventh Street, SW Arlington, Virginia 22203 Washington, D.C. 20590		10. Work Unit No. (TRAIS)	
15. Supplementary Notes Project Manager: Mr. Jorge E. Pagán-Ortiz, FHWA Technical Assistants: Larry Arneson, J. Sterling Jones, Jorge E. Pagán-Ortiz, FHWA; A. Firenzi, Johnny L. Morris, E.V. Richardson, W.J. Spitz, Arlo Waddoups, Ayres Associates		11. Contract or Grant No. DTFH61-00-T-25060	
16. This document identifies and provides design guidelines for bridge scour and stream instability countermeasures that have been implemented by various State departments of transportation (DOTs) in the United States. Countermeasure experience, selection, and design guidance are consolidated from other FHWA publications in this document to support a comprehensive analysis of scour and stream instability problems and provide a range of solutions to those problems. Selected innovative countermeasure concepts and guidance derived from practice outside the United States are introduced. Management strategies for developing a Plan of Action for scour critical bridges are outlined, and guidance is provided for scour monitoring using portable and fixed instrumentation. In addition to minor editorial revisions, the following substantive changes have been made in this revised edition of HEC-23: corrected definition of density of water, ρ , (p. ix); and corrected multiplier for kinematic viscosity in Appendix A (Table A.7).		13. Type of Report and Period Covered	
17. Key Words stream stability, scour, countermeasures, plan of action, bendway weirs, soil cement, wire enclosed riprap, articulated concrete block systems, cable-tied concrete, grout filled mattresses, grout bags, rock riprap, spurs, guide banks, check dams, revetments, scour monitoring instrumentation	18. Distribution Statement This document is available to the public through the National Technical Information Service, Springfield, VA 22161 (703) 487-4650		
19. Security Classif. (of this report) Unclassified	20. Security Classif. (of this page) Unclassified	21. No. of Pages 398	22. Price

TABLE OF CONTENTS

DESIGN GUIDELINES	iv
LIST OF FIGURES	v
LIST OF TABLES	vii
LIST OF SYMBOLS.....	ix
ACKNOWLEDGMENTS	x
GLOSSARY.....	xi
CHAPTER 1. INTRODUCTION	1.1
1.1 PURPOSE	1.1
1.2 BACKGROUND	1.1
1.3 MANUAL ORGANIZATION.....	1.1
1.4 COMPREHENSIVE ANALYSIS	1.2
1.5 PLAN OF ACTION.....	1.4
1.6 DUAL SYSTEM OF UNITS.....	1.5
CHAPTER 2. PLAN OF ACTION AND THE COUNTERMEASURES MATRIX	2.1
2.1 STRATEGIES FOR PROTECTING SCOUR CRITICAL BRIDGES.....	2.1
2.1.1 Technical Advisories.....	2.1
2.1.2 Management Strategies for a Plan of Action	2.2
2.1.3 Inspection Strategies in a Plan of Action	2.3
2.1.4 Closure Instructions	2.4
2.1.5 Countermeasure Alternatives and Schedule.....	2.4
2.1.6 Other Information Necessary in a Plan of Action.....	2.5
2.1.7 Identifying Countermeasures for the Plan of Action.....	2.5
2.2 OVERVIEW OF THE MATRIX.....	2.5
2.3 COUNTERMEASURE GROUPS	2.10
2.3.1 Group 1. Hydraulic Countermeasures.....	2.10
2.3.2 Group 2. Structural Countermeasures.....	2.11
2.3.3 Group 3. Monitoring	2.12
2.4 BIOLOGICAL COUNTERMEASURES.....	2.12
2.5 COUNTERMEASURE CHARACTERISTICS	2.12
2.5.1 Functional Applications	2.13
2.5.2 Suitable River Environment	2.14
2.5.3 Maintenance	2.14
2.5.4 Installation/Experience by State Departments of Transportation	2.15
2.5.5 Design Guideline Reference	2.15
2.6 SUMMARY	2.15
CHAPTER 3. CONSIDERATIONS FOR SELECTING COUNTERMEASURES	3.1
3.1 INTRODUCTION	3.1
3.2 SELECTION OF COUNTERMEASURES FOR STREAM INSTABILITY.....	3.2
3.2.1 Erosion Mechanism	3.2
3.2.2 Stream Characteristics.....	3.2
3.2.3 Construction and Maintenance Requirements.....	3.4

3.2.4	Vandalism	3.4
3.2.5	Costs	3.4
3.3	COUNTERMEASURES FOR MEANDER MIGRATION	3.4
3.4	COUNTERMEASURES FOR CHANNEL BRAIDING AND ANABRANCHING	3.7
3.5	COUNTERMEASURES FOR DEGRADATION AND AGGRADATION	3.7
3.5.1	Countermeasures to Control Degradation	3.8
3.5.2	Countermeasures to Control Aggradation	3.9
3.6	SELECTION OF COUNTERMEASURES FOR SCOUR AT BRIDGES	3.10
3.6.1	Countermeasures for Contraction Scour	3.11
3.6.2	Countermeasures for Local Scour	3.12
3.6.3	Monitoring	3.14
CHAPTER 4. COUNTERMEASURE DESIGN CONCEPTS		4.1
4.1	COUNTERMEASURE DESIGN APPROACH	4.1
4.1.1	Investment in Countermeasures	4.1
4.1.2	Design Approach	4.1
4.2	ENVIRONMENTAL PERMITTING	4.2
4.3	HYDRAULIC ANALYSIS	4.3
4.3.1	Overview	4.3
4.3.2	Physical Models	4.4
4.3.3	Scour at Transverse Structures	4.6
4.3.4	Scour at Longitudinal Structures	4.6
4.3.5	Scour at Protected Bendways	4.9
4.4	RIPRAP	4.13
4.4.1	Overview	4.13
4.4.2	Turbulence Intensity	4.14
4.4.3	Grouted and Partially Grouted Riprap	4.14
4.4.4	Armor Units	4.15
4.4.5	Concrete Prisms and Cubes	4.17
4.4.6	Installation Techniques	4.19
4.5	FILTER REQUIREMENTS	4.20
4.5.1	Overview	4.20
4.5.2	Fascine Mats	4.20
4.5.3	Geotextile Containers	4.21
4.6	EDGE TREATMENT	4.23
4.7	BIOTECHNICAL ENGINEERING	4.23
4.7.1	Overview	4.23
4.7.2	Advantages and Disadvantages of Biotechnical Engineering	4.24
4.7.3	Design Considerations for Biotechnical Engineering	4.25
4.7.4	Streambank Zones	4.27
4.7.5	Biotechnical Engineering Treatments	4.28
4.7.6	Summary	4.30

CHAPTER 5. COUNTERMEASURE DESIGN GUIDELINES.....	5.1
5.1 INTRODUCTION	5.1
5.2 DESIGN GUIDELINES	5.1
CHAPTER 6. OTHER COUNTERMEASURES AND CASE HISTORIES OF PERFORMANCE	6.1
6.1 INTRODUCTION	6.1
6.2 HARDPOINTS	6.1
6.3 RETARDER STRUCTURES.....	6.1
6.3.1 Jacks and Tetrahedrons.....	6.2
6.3.2 Fence Retarder Structures.....	6.4
6.3.3 Timber Pile.....	6.4
6.3.4 Wood Fence	6.5
6.4 LONGITUDINAL DIKES.....	6.5
6.4.1 Earth or Rock Embankments	6.8
6.4.2 Rock Toe-Dikes	6.8
6.4.3 Crib Dikes	6.8
6.4.4 Bulkheads.....	6.8
6.5 CHANNEL RELOCATION.....	6.11
6.6 CASE HISTORIES OF COUNTERMEASURE PERFORMANCE.....	6.13
6.6.1 Flexible Revetment	6.14
6.6.2 Rigid Revetments.....	6.15
6.6.3 Bulkheads.....	6.16
6.6.4 Spurs	6.16
6.6.5 Retardance Structures	6.17
6.6.6 Dikes.....	6.18
6.6.7 Guide Banks	6.18
6.6.8 Check Dams	6.19
6.6.9 Jack or Tetrahedron Fields	6.19
6.6.10 Special Devices for Protection of Piers	6.20
6.6.11 Willow/Board Mattress	6.20
6.6.12 Channel Alterations.....	6.20
6.6.13 Modification of Bridge Length and Relief Structures.....	6.21
6.6.14 Investment in Countermeasures	6.21
CHAPTER 7. SCOUR MONITORING AND INSTRUMENTATION.....	7.1
7.1 INTRODUCTION	7.1
7.2 PORTABLE INSTRUMENTATION.....	7.2
7.2.1 Components of a Portable Instrument System	7.2
7.2.2 Instrument for Making the Measurement.....	7.2
7.2.3 System for Deploying the Instrument	7.7
7.2.4 Positioning Information	7.9
7.2.5 Data Storage Devices	7.10
7.3 FIXED INSTRUMENTATION.....	7.11
7.3.1 NCHRP Project 21-3.....	7.11
7.3.2 Scour Measurement.....	7.11
7.3.3 Laboratory Testing.....	7.13
7.3.4 Field Testing	7.14

7.3.5	Evaluation of Instrument Performance	7.20
7.3.6	Application Guidelines	7.22
7.3.7	Summary	7.22
7.4	SELECTING INSTRUMENTATION	7.23
7.5	FIXED INSTRUMENT FIELD INSTALLATIONS	7.27
7.5.1	Introduction	7.27
7.5.2	Typical Field Installations	7.27
CHAPTER 8.	REFERENCES	8.1

DESIGN GUIDELINES

DESIGN GUIDELINE 1 - BENDWAY WEIRS/STREAM BARBS.....	DG1.1
DESIGN GUIDELINE 2 - SOIL CEMENT	DG2.1
DESIGN GUIDELINE 3 - WIRE ENCLOSED RIPRAP MATTRESS.....	DG3.1
DESIGN GUIDELINE 4 - ARTICULATED CONCRETE BLOCK SYSTEM.....	DG4.1
DESIGN GUIDELINE 5 - GROUT FILLED MATTRESSES	DG5.1
DESIGN GUIDELINE 6 - CONCRETE ARMOR UNITS	DG6.1
DESIGN GUIDELINE 7 - GROUT/CEMENT FILLED BAGS	DG7.1
DESIGN GUIDELINE 8 - ROCK RIPRAP AT PIERS AND ABUTMENTS	DG8.1
DESIGN GUIDELINE 9 - SPURS	DG9.1
DESIGN GUIDELINE 10 - GUIDE BANKS	DG10.1
DESIGN GUIDELINE 11 - CHECK DAMS/DROP STRUCTURES.....	DG11.1
DESIGN GUIDELINE 12 - REVETMENTS	DG12.1
APPENDIX A - METRIC SYSTEM, CONVERSION FACTORS, AND WATER PROPERTIES.....	A.1

LIST OF FIGURES

Figure 1.1	Flow chart for scour and stream stability analysis and evaluation	1.3
Figure 3.1	Countermeasure costs per meter of bank protected	3.5
Figure 3.2	Comparison of channel bend cross sections (a) for natural conditions, and (b) for stabilized bend	3.6
Figure 3.3	Meander migration in (a) a natural channel, and (b) a channel with stabilized bend	3.6
Figure 3.4	Typical guide bank layout and section	3.13
Figure 4.1	BAW laboratory, Karlsruhe, Germany, pier scour model of railway bridge over Rhine River near Mannheim	4.5
Figure 4.2	Scour along a vertical wall as a function of unconstrained valley width	4.9
Figure 4.3	Definition sketch of width (W) and mean water depth (D_{mnc}) at the crossing upstream of the bend and maximum water depth in the bend (D_{mxb})	4.11
Figure 4.4	Relationship between radial stress and structure type for South Fork Tillatoba Creek, Mississippi, based on a 2-year return period discharge.....	4.12
Figure 4.5	Partially grouted riprap undergoing testing at the Federal Waterway Engineering and Research Institute (BAW), Karlsruhe, Germany.....	4.16
Figure 4.6	"Conglomerate" of partially grouted riprap, Federal Waterway Engineering and Research Institute, Karlsruhe, Germany	4.16
Figure 4.7	Reuss River bridge failure near Wassen, Uri Canton Switzerland, August 1987	4.18
Figure 4.8	Massive precast concrete prisms placed as a groin field, Switzerland	4.18
Figure 4.9	Concrete cube bank revetment, Waimakariri River, New Zealand	4.19
Figure 4.10	Bottom dump pontoon barge used in Germany for placing riprap	4.20
Figure 4.11	Fascine mattress: Fascine bundles tied on a base of woven geosynthetic fabric	4.21
Figure 4.12	Batch plant for filling numerous geotextile containers on-site.....	4.22
Figure 4.13	Schematic of pier scour repair using geocontainers as filter and fill, and partially grouted riprap as cover layer.....	4.22
Figure 4.14	Details of brush mattress technique with stone toe protection.....	4.26
Figure 4.15	Details of rootwad and boulder revetment technique.....	4.26
Figure 4.16	Bank zones defined for slope protection	4.27

Figure 6.1	Perspective view of hardpoint installation with section detail.....	6.2
Figure 6.2	Typical tetrahedron design.....	6.3
Figure 6.3	Typical jack unit.....	6.3
Figure 6.4	Retarder field schematic.....	6.4
Figure 6.5	Timber pile bent retarder structure.....	6.5
Figure 6.6	Typical wood fence retarder structure.....	6.6
Figure 6.7	Light double row wire fence retarder structure.....	6.6
Figure 6.8	Heavy timber-pile and wire fence retarder structures.....	6.7
Figure 6.9	Typical longitudinal rock toe-dike geometries.....	6.9
Figure 6.10	Longitudinal rock toe-dike tiebacks.....	6.9
Figure 6.11	Timber pile, wire mesh crib dike with tiebacks.....	6.10
Figure 6.12	Anchorage schemes for a sheetpile bulkhead.....	6.11
Figure 6.13	Encroachments on meandering streams.....	6.12
Figure 7.1	Sounding pole measurement.....	7.4
Figure 7.2	Lead-line sounding weight.....	7.4
Figure 7.3	Portable sonar in use.....	7.5
Figure 7.4	Kneeboard float.....	7.5
Figure 7.5	Pontoon float.....	7.6
Figure 7.6	AIDI system.....	7.6
Figure 7.7	Geophysical instrument in use.....	7.7
Figure 7.8	FHWA articulated arm in use.....	7.8
Figure 7.9	Unmanned, remote control boat.....	7.10
Figure 7.10	Manual read out magnetic sliding collar device.....	7.16
Figure 7.11	Automated read out magnetic sliding collar system.....	7.17
Figure 7.12	Above-water serviceable low-cost fathometer system.....	7.19
Figure 7.13	Installation of a sonar scour monitor on Salinas River bridge near Soledad, California (Highway 101) by CALTRANS.....	7.29
Figure 7.14	Close up of sonar scour monitor on Salinas River bridge near Soledad, CA.....	7.29
Figure 7.15	CALTRANS drilling with hollow stem auger for installation of float out devices at Salinas River bridge (Highway 101) near Soledad, CA.....	7.30

Figure 7.16	Installation of float out device on Salinas River bridge near Soledad, CA.....	7.30
Figure 7.17	Typical instrument shelter with data logger, cell-phone telemetry, and a solar panel/gel-cell for power	7.31
Figure 7.18	Installation of a float out device by Nevada DOT to monitor riprap stability.....	7.32

LIST OF TABLES

Table 1.1	Commonly Used Engineering Terms in SI and English Units.....	1.5
Table 2.1	Stream Instability and Bridge Scour Countermeasures Matrix	2.7
Table 7.1	Comparison of Devices Tested With Mandatory and Desirable Criteria	7.21
Table 7.2	Instrumentation Summary by Category.....	7.24
Table 7.3	Portable Instrumentation Summary.....	7.25
Table 7.4	Fixed Instrumentation Summary	7.25
Table 7.5	Positioning System Summary	7.26
Table 7.6	Estimated Cost Information	7.26

(page intentionally left blank)

LIST OF SYMBOLS

a	=	structure length projecting normal to the flow, m (ft)
A_b	=	area of outer bank (m^2 or ft^2)
D_{50}	=	riprap size, m (ft)
D_{mxb}	=	maximum water depth in the bend, m (ft)
D_{mnc}	=	average water depth in the crossing upstream of the bend, m (ft)
F	=	centripetal force, N (lbs)
F_r	=	upstream Froude Number
K	=	coefficient
Q	=	discharge, m^3/s (ft^3/s)
R_c	=	centerline radius of the bend, m (ft)
S_s	=	specific gravity of the riprap (usually 2.65)
V	=	flow velocity, m/s (ft/s)
W	=	width (or topwidth) of the bend, m (ft)
Y	=	mean flow depth, m (ft)
y_s	=	equilibrium depth of scour (measured from the mean bed level to the bottom of the scour hole), m (ft)
y_1	=	average upstream flow depth in the main channel or on the overbank, m (ft)
θ	=	angle between the impinging flow direction and the vertical wall
ρ	=	fluid density, kg/m^3 (slugs/ ft^3)

ACKNOWLEDGMENTS

This manual is a major revision of the first edition of HEC-23 which was published in 1997. The writers wish to acknowledge the contributions made by Morgan S. Byars (formerly Ayres Associates) as a co-author of the first edition. Mr. Byars was responsible for contacting and coordinating state and federal agency input to selected design guidelines for the first edition.

GLOSSARY

abrasion:	Removal of streambank material due to entrained sediment, ice, or debris rubbing against the bank.
aggradation:	General and progressive buildup of the longitudinal profile of a channel bed due to sediment deposition.
alluvial channel:	Channel wholly in alluvium; no bedrock is exposed in channel at low flow or likely to be exposed by erosion.
alluvial fan:	A fan-shaped deposit of material at the place where a stream issues from a narrow valley of high slope onto a plain or broad valley of low slope. An alluvial cone is made up of the finer materials suspended in flow while a debris cone is a mixture of all sizes and kinds of materials.
alluvial stream:	A stream which has formed its channel in cohesive or noncohesive materials that have been and can be transported by the stream.
alluvium:	Unconsolidated material deposited by a stream in a channel, floodplain, alluvial fan, or delta.
alternating bars:	Elongated deposits found alternately near the right and left banks of a channel.
anabranch:	Individual channel of an anabranching stream.
anabranching stream:	A stream whose flow is divided at normal and lower stages by large islands or, more rarely, by large bars; individual islands or bars are wider than about three times water width; channels are more widely and distinctly separated than in a braided stream.
anastomosing stream:	An anabranching stream.
angle of repose:	The maximum angle (as measured from the horizontal) at which gravel or sand particles can stand.
annual flood:	The maximum flow in one year (may be daily or instantaneous).
apron:	Protective material placed on a streambed to resist scour.
apron, launching:	An apron designed to settle and protect the side slopes of a scour hole after settlement.
armor (armoring):	Surfacing of channel bed, banks, or embankment slope to resist erosion and scour. (a) Natural process whereby an erosion-resistant layer of relatively large particles is formed on a streambed due to the removal of finer particles by streamflow; (b) placement of a covering to resist erosion.

articulated concrete mattress:	Rigid concrete slabs which can move without separating as scour occurs; usually hinged together with corrosion-resistant cable fasteners; primarily placed for lower bank protection.
average velocity:	Velocity at a given cross section determined by dividing discharge by cross sectional area.
avulsion:	A sudden change in the channel course that usually occurs when a stream breaks through its banks; usually associated with a flood or a catastrophic event.
backfill:	The material used to refill a ditch or other excavation, or the process of doing so.
backwater:	The increase in water surface elevation relative to the elevation occurring under natural channel and floodplain conditions. It is induced by a bridge or other structure that obstructs or constricts the free flow of water in a channel.
backwater area:	The low-lying lands adjacent to a stream that may become flooded due to backwater.
bank:	The sides of a channel between which the flow is normally confined.
bank, left (right):	The side of a channel as viewed in a downstream direction.
bankfull discharge:	Discharge that, on the average, fills a channel to the point of overflowing.
bank protection:	Engineering works for the purpose of protecting streambanks from erosion.
bank revetment:	Erosion-resistant materials placed directly on a streambank to protect the bank from erosion.
bar:	An elongated deposit of alluvium within a channel, not permanently vegetated.
base floodplain:	The floodplain associated with the flood with a 100-year recurrence interval.
bed:	The bottom of a channel bounded by banks.
bed form:	A recognizable relief feature on the bed of a channel, such as a ripple, dune, plane bed, antidune, or bar. Bed forms are a consequence of the interaction between hydraulic forces (boundary shear stress) and the bed sediment.
bed layer:	A flow layer, several grain diameters thick (usually two) immediately above the bed.

bed load:	Sediment that is transported in a stream by rolling, sliding, or skipping along the bed or very close to it; considered to be within the bed layer (contact load).
bed load discharge (or bed load):	The quantity of bed load passing a cross section of a stream in a unit of time.
bed material:	Material found in and on the bed of a stream (May be transported as bed load or in suspension).
bedrock:	The solid rock exposed at the surface of the earth or overlain by soils and unconsolidated material.
bed sediment discharge:	The part of the total sediment discharge that is composed of grain sizes found in the bed and is equal to the transport capability of the flow.
bed shear (tractive force):	The force per unit area exerted by a fluid flowing past a stationary boundary.
bed slope:	The inclination of the channel bottom.
blanket:	Material covering all or a portion of a streambank to prevent erosion.
boulder:	A rock fragment whose diameter is greater than 250 mm.
braid:	A subordinate channel of a braided stream.
braided stream:	A stream whose flow is divided at normal stage by small mid-channel bars or small islands; the individual width of bars and islands is less than about three times water width; a braided stream has the aspect of a single large channel within which are subordinate channels.
bridge opening:	The cross-sectional area beneath a bridge that is available for conveyance of water.
bridge waterway:	The area of a bridge opening available for flow, as measured below a specified stage and normal to the principal direction of flow.
bulk density:	Density of the water sediment mixture (mass per unit volume), including both water and sediment.
bulkhead:	A vertical, or near vertical, wall that supports a bank or an embankment; also may serve to protect against erosion.
bulking:	Increasing the water discharge to account for high concentrations of sediment in the flow.
catchment:	See drainage basin.

causeway:	Rock or earth embankment carrying a roadway across water.
caving:	The collapse of a bank caused by undermining due to the action of flowing water.
cellular-block mattress:	Interconnected concrete blocks with regular cavities placed directly on a streambank or filter to resist erosion. The cavities can permit bank drainage and the growth of vegetation where synthetic filter fabric is not used between the bank and mattress.
channel:	The bed and banks that confine the surface flow of a stream.
channelization:	Straightening or deepening of a natural channel by artificial cutoffs, grading, flow-control measures, or diversion of flow into an engineered channel.
channel diversion:	The removal of flows by natural or artificial means from a natural length of channel.
channel pattern:	The aspect of a stream channel in plan view, with particular reference to the degree of sinuosity, braiding, and anabranching.
channel process:	Behavior of a channel with respect to shifting, erosion and sedimentation.
check dam:	A low dam or weir across a channel used to control stage or degradation.
choking (of flow):	Excessive constriction of flow which may cause severe backwater effect.
clay (mineral):	A particle whose diameter is in the range of 0.00024 to 0.004 mm.
clay plug:	A cutoff meander bend filled with fine grained cohesive sediments.
clear-water scour:	Scour at a pier or abutment (or contraction scour) when there is no movement of the bed material upstream of the bridge crossing at the flow causing bridge scour.
cobble:	A fragment of rock whose diameter is in the range of 64 to 250 mm.
concrete revetment:	Unreinforced or reinforced concrete slabs placed on the channel bed or banks to protect it from erosion.
confluence:	The junction of two or more streams.
constriction:	A natural or artificial control section, such as a bridge crossing, channel reach or dam, with limited flow capacity in which the upstream water surface elevation is related to discharge.
contact load:	Sediment particles that roll or slide along in almost continuous contact with the streambed (bed load).

contraction:	The effect of channel or bridge constriction on flow streamlines.
contraction scour:	Contraction scour, in a natural channel or at a bridge crossing, involves the removal of material from the bed and banks across all or most of the channel width. This component of scour results from a contraction of the flow area at the bridge which causes an increase in velocity and shear stress on the bed at the bridge. The contraction can be caused by the bridge or from a natural narrowing of the stream channel.
Coriolis force:	The inertial force caused by the Earth's rotation that deflects a moving body to the right in the Northern Hemisphere.
countermeasure:	A measure intended to prevent, delay or reduce the severity of hydraulic problems.
crib:	A frame structure filled with earth or stone ballast, designed to reduce energy and to deflect streamflow away from a bank or embankment.
critical shear stress:	The minimum amount of shear stress required to initiate soil particle motion.
crossing:	The relatively short and shallow reach of a stream between bends; also crossover or riffle.
cross section:	A section normal to the trend of a channel or flow.
current:	Water flowing through a channel.
current meter:	An instrument used to measure flow velocity.
cut bank:	The concave wall of a meandering stream.
cutoff:	(a) A direct channel, either natural or artificial, connecting two points on a stream, thereby shortening the original length of the channel and increasing its slope; (b) A natural or artificial channel which develops across the neck of a meander loop (neck cutoff) or across a point bar (chute cutoff).
cutoff wall:	A wall, usually of sheet piling or concrete, that extends down to scour-resistant material or below the expected scour depth.
daily discharge:	Discharge averaged over one day (24 hours).
debris:	Floating or submerged material, such as logs, vegetation, or trash, transported by a stream.
degradation (bed):	A general and progressive (long-term) lowering of the channel bed due to erosion, over a relatively long channel length.

depth of scour:	The vertical distance a streambed is lowered by scour below a reference elevation.
design flow (design flood):	The discharge that is selected as the basis for the design or evaluation of a hydraulic structure.
dike:	An impermeable linear structure for the control or containment of overbank flow. A dike-trending parallel with a streambank differs from a levee in that it extends for a much shorter distance along the bank, and it may be surrounded by water during floods.
dike (groin, spur, jetty):	A structure extending from a bank into a channel that is designed to: (a) reduce the stream velocity as the current passes through the dike, thus encouraging sediment deposition along the bank (permeable dike); or (b) deflect erosive current away from the streambank (impermeable dike).
discharge:	Volume of water passing through a channel during a given time.
dominant discharge:	(a) The discharge of water which is of sufficient magnitude and frequency to have a dominating effect in determining the characteristics and size of the stream course, channel, and bed; (b) That discharge which determines the principal dimensions and characteristics of a natural channel. The dominant formative discharge depends on the maximum and mean discharge, duration of flow, and flood frequency. For hydraulic geometry relationships, it is taken to be the bankfull discharge which has a return period of approximately 1.5 years in many natural channels.
drainage basin:	An area confined by drainage divides, often having only one outlet for discharge (catchment, watershed).
drift:	Alternative term for vegetative "debris."
eddy current:	A vortex-type motion of a fluid flowing contrary to the main current, such as the circular water movement that occurs when the main flow becomes separated from the bank.
entrenched stream:	Stream cut into bedrock or consolidated deposits.
ephemeral stream:	A stream or reach of stream that does not flow for parts of the year. As used here, the term includes intermittent streams with flow less than perennial.
equilibrium scour:	Scour depth in sand-bed stream with dune bed about which live bed pier scour level fluctuates due to variability in bed material transport in the approach flow.
erosion:	Displacement of soil particles due to water or wind action.

erosion control matting:	Fibrous matting (e.g., jute, paper, etc.) placed or sprayed on a streambank for the purpose of resisting erosion or providing temporary stabilization until vegetation is established.
fabric mattress:	Grout-filled mattress used for streambank protection.
fall velocity:	The velocity at which a sediment particle falls through a column of still water.
fascine:	A matrix of willow or other natural material woven in bundles and used as a filter. Also, a streambank protection technique consisting of wire mesh or timber attached to a series of posts, sometimes in double rows; the space between the rows may be filled with rock, brush, or other materials.
fetch:	The area in which waves are generated by wind having a rather constant direction and speed; sometimes used synonymously with fetch length.
fetch length:	The horizontal distance (in the direction of the wind) over which wind generates waves and wind setup.
fill slope:	Side or end slope of an earth-fill embankment. Where a fill-slope forms the streamward face of a spill-through abutment, it is regarded as part of the abutment.
filter:	Layer of fabric (geotextile) or granular material (sand, gravel, or graded rock) placed between bank revetment (or bed protection) and soil for the following purposes: (1) to prevent the soil from moving through the revetment by piping, extrusion, or erosion; (2) to prevent the revetment from sinking into the soil; and (3) to permit natural seepage from the streambank, thus preventing the buildup of excessive hydrostatic pressure.
filter blanket:	A layer of graded sand and gravel laid between fine-grained material and riprap to serve as a filter.
filter fabric (cloth):	Geosynthetic fabric that serves the same purpose as a granular filter blanket.
fine sediment load:	That part of the total sediment load that is composed of particle sizes finer than those represented in the bed (wash load). Normally, the fine-sediment load is finer than 0.062 mm for sand-bed channels. Silts, clays and sand could be considered wash load in coarse gravel and cobble-bed channels.
flanking:	Erosion around the landward end of a stream stabilization countermeasure.

flashy stream:	Stream characterized by rapidly rising and falling stages, as indicated by a sharply peaked hydrograph. Typically associated with mountain streams or highly disturbed urbanized catchments. Most flashy streams are ephemeral, but some are perennial.
flood-frequency curve:	A graph indicating the probability that the annual flood discharge will exceed a given magnitude, or the recurrence interval corresponding to a given magnitude.
floodplain:	A nearly flat, alluvial lowland bordering a stream, that is subject to frequent inundation by floods.
flow-control structure:	A structure either within or outside a channel that acts as a countermeasure by controlling the direction, depth, or velocity of flowing water.
flow hazard:	Flow characteristics (discharge, stage, velocity, or duration) that are associated with a hydraulic problem or that can reasonably be considered of sufficient magnitude to cause a hydraulic problem or to test the effectiveness of a countermeasure.
flow slide:	Saturated soil materials which behave more like a liquid than a solid. A flow slide on a channel bank can result in a bank failure.
fluvial geomorphology:	The science dealing with the morphology (form) and dynamics of streams and rivers.
fluvial system:	The natural river system consisting of (1) the drainage basin, watershed, or sediment source area, (2) tributary and mainstem river channels or sediment transfer zone, and (3) alluvial fans, valley fills and deltas, or the sediment deposition zone.
freeboard:	The vertical distance above a design stage that is allowed for waves, surges, drift, and other contingencies.
Froude Number:	A dimensionless number that represents the ratio of inertial to gravitational forces in open channel flow.
gabion:	A basket or compartmented rectangular container made of wire mesh. When filled with cobbles or other rock of suitable size, the gabion becomes a flexible and permeable unit with which flow- and erosion-control structures can be built.
general scour:	General scour is a lowering of the streambed across the stream or waterway at the bridge. This lowering may be uniform across the bed or non-uniform. That is, the depth of scour may be deeper in some parts of the cross section. General scour may result from contraction of the flow or other general scour conditions such as flow around a bend.

geomorphology/ morphology:	That science that deals with the form of the Earth, the general configuration of its surface, and the changes that take place due to erosion and deposition.
grade-control structure (sill, check dam):	Structure placed bank to bank across a stream channel (usually with its central axis perpendicular to flow) for the purpose of controlling bed slope and preventing scour or headcutting.
graded stream:	A geomorphic term used for streams that have apparently achieved a state of equilibrium between the rate of sediment transport and the rate of sediment supply throughout long reaches.
gravel:	A rock fragment whose diameter ranges from 2 to 64 mm.
groin:	A structure built from the bank of a stream in a direction transverse to the current to redirect the flow or reduce flow velocity. Many names are given to this structure, the most common being "spur," "spur dike," "transverse dike," "jetty," etc. Groins may be permeable, semi-permeable, or impermeable.
grout:	A fluid mixture of cement and water or of cement, sand, and water used to fill joints and voids.
guide bank:	A dike extending upstream from the approach embankment at either or both sides of the bridge opening to direct the flow through the opening. Some guidebanks extend downstream from the bridge (also spur dike).
hardpoint:	A streambank protection structure whereby "soft" or erodible materials are removed from a bank and replaced by stone or compacted clay. Some hard points protrude a short distance into the channel to direct erosive currents away from the bank. Hard points also occur naturally along streambanks as passing currents remove erodible materials leaving nonerodible materials exposed.
headcutting:	Channel degradation associated with abrupt changes in the bed elevation (headcut) that generally migrates in an upstream direction.
helical flow:	Three-dimensional movement of water particles along a spiral path in the general direction of flow. These secondary-type currents are of most significance as flow passes through a bend; their net effect is to remove soil particles from the cut bank and deposit this material on a point bar.
hydraulics:	The applied science concerned with the behavior and flow of liquids, especially in pipes, channels, structures, and the ground.
hydraulic model:	A small-scale physical or mathematical representation of a flow situation.
hydraulic problem:	An effect of streamflow, tidal flow, or wave action such that the integrity of the highway facility is destroyed, damaged, or endangered.

hydraulic radius:	The cross-sectional area of a stream divided by its wetted perimeter.
hydraulic structures:	The facilities used to impound, accommodate, convey or control the flow of water, such as dams, weirs, intakes, culverts, channels, and bridges.
hydrograph:	The graph of stage or discharge against time.
hydrology:	The science concerned with the occurrence, distribution, and circulation of water on the earth.
imbricated:	In reference to stream bed sediment particles, having an overlapping or shingled pattern.
icing:	Masses or sheets of ice formed on the frozen surface of a river or floodplain. When shoals in the river are frozen to the bottom or otherwise dammed, water under hydrostatic pressure is forced to the surface where it freezes.
incised reach:	A stretch of stream with an incised channel that only rarely overflows its banks.
incised stream:	A stream which has deepened its channel through the bed of the valley floor, so that the floodplain is a terrace.
invert:	The lowest point in the channel cross section or at flow control devices such as weirs, culverts, or dams.
island:	A permanently vegetated area, emergent at normal stage, that divides the flow of a stream. Islands originate by establishment of vegetation on a bar, by channel avulsion, or at the junction of minor tributary with a larger stream.
jack:	A device for flow control and protection of banks against lateral erosion consisting of three mutually perpendicular arms rigidly fixed at the center. Kellner jacks are made of steel struts strung with wire, and concrete jacks are made of reinforced concrete beams.
jack field:	Rows of jacks tied together with cables, some rows generally parallel with the banks and some perpendicular thereto or at an angle. Jack fields may be placed outside or within a channel.
jetty:	(a) An obstruction built of piles, rock, or other material extending from a bank into a stream, so placed as to induce bank building, or to protect against erosion; (b) A similar obstruction to influence stream, lake, or tidal currents, or to protect a harbor (also spur).
lateral erosion:	Erosion in which the removal of material is extended horizontally as contrasted with degradation and scour in a vertical direction.
launching:	Release of undercut material (stone riprap, rubble, slag, etc.) downslope or into a scoured area.

levee:	An embankment, generally landward of top bank, that confines flow during high-water periods, thus preventing overflow into lowlands.
live-bed scour:	Scour at a pier or abutment (or contraction scour) when the bed material in the channel upstream of the bridge is moving at the flow causing bridge scour.
load (or sediment load):	Amount of sediment being moved by a stream.
local scour:	Removal of material from around piers, abutments, spurs, and embankments caused by an acceleration of flow and resulting vortices induced by obstructions to the flow.
longitudinal profile:	The profile of a stream or channel drawn along the length of its centerline. In drawing the profile, elevations of the water surface or the thalweg are plotted against distance as measured from the mouth or from an arbitrary initial point.
lower bank:	That portion of a streambank having an elevation less than the mean water level of the stream.
mathematical model:	A numerical representation of a flow situation using mathematical equations (also computer model).
mattress:	A blanket or revetment of materials interwoven or otherwise lashed together and placed to cover an area subject to scour.
meander or full meander:	A meander in a river consists of two consecutive loops, one flowing clockwise and the other counter-clockwise.
meander amplitude:	The distance between points of maximum curvature of successive meanders of opposite phase in a direction normal to the general course of the meander belt, measured between center lines of channels.
meander belt:	The distance between lines drawn tangent to the extreme limits of successive fully developed meanders.
meander length:	The distance along a stream between corresponding points of successive meanders.
meander loop:	An individual loop of a meandering or sinuous stream lying between inflection points with adjoining loops.
meander ratio:	The ratio of meander width to meander length.
meander radius of curvature:	The radius of a circle inscribed on the centerline of a meander loop.
meander scrolls:	Low, concentric ridges and swales on a floodplain, marking the successive positions of former meander loops.

meander width:	The amplitude of a fully developed meander measured from midstream to midstream.
meandering stream:	A stream having a sinuosity greater than some arbitrary value. The term also implies a moderate degree of pattern symmetry, imparted by regularity of size and repetition of meander loops. The channel generally exhibits a characteristic process of bank erosion and point bar deposition associated with systematically shifting meanders.
median diameter:	The particle diameter of the 50th percentile point on a size distribution curve such that half of the particles (by weight, number, or volume) are larger and half are smaller (D_{50} .)
mid-channel bar:	A bar lacking permanent vegetal cover that divides the flow in a channel at normal stage.
middle bank:	The portion of a streambank having an elevation approximately the same as that of the mean water level of the stream.
migration:	Change in position of a channel by lateral erosion of one bank and simultaneous accretion of the opposite bank.
mud:	A soft, saturated mixture mainly of silt and clay.
natural levee:	A low ridge that slopes gently away from the channel banks that is formed along streambanks during floods by deposition.
nominal diameter:	Equivalent spherical diameter of a hypothetical sphere of the same volume as a given sediment particle.
nonalluvial channel:	A channel whose boundary is in bedrock or non-erodible material.
normal stage:	The water stage prevailing during the greater part of the year.
overbank flow:	Water movement that overtops the bank either due to stream stage or to overland surface water runoff.
oxbow:	The abandoned former meander loop that remains after a stream cuts a new, shorter channel across the narrow neck of a meander. Often bow-shaped or horseshoe-shaped.
pavement:	Streambank surface covering, usually impermeable, designed to serve as protection against erosion. Common pavements used on streambanks are concrete, compacted asphalt, and soil-cement.
paving:	Covering of stones on a channel bed or bank (used with reference to natural covering).
peaked stone dike:	Riprap placed parallel to the toe of a streambank (at the natural angle of repose of the stone) to prevent erosion of the toe and induce sediment deposition behind the dike.

perennial stream:	A stream or reach of a stream that flows continuously for all or most of the year.
phreatic line:	The upper boundary of the seepage water surface landward of a streambank.
pile:	An elongated member, usually made of timber, concrete, or steel, that serves as a structural component of a river-training structure.
pile dike:	A type of permeable structure for the protection of banks against caving; consists of a cluster of piles driven into the stream, braced and lashed together.
pipng:	Removal of soil material through subsurface flow of seepage water that develops channels or "pipes" within the soil bank.
point bar:	An alluvial deposit of sand or gravel lacking permanent vegetal cover occurring in a channel at the inside of a meander loop, usually somewhat downstream from the apex of the loop.
poised stream:	A stream which, as a whole, maintains its slope, depths, and channel dimensions without any noticeable raising or lowering of its bed (stable stream). Such condition may be temporary from a geological point of view, but for practical engineering purposes, the stream may be considered stable.
probable maximum flood:	A very rare flood discharge value computed by hydrometeorological methods, usually in connection with major hydraulic structures.
quarry-run stone:	Stone as received from a quarry without regard to gradation requirements.
railbank protection:	A type of countermeasure composed of rock-filled wire fabric supported by steel rails or posts driven into streambed.
rapid drawdown:	Lowering the water against a bank more quickly than the bank can drain without becoming unstable.
reach:	A segment of stream length that is arbitrarily bounded for purposes of study.
recurrence interval:	The reciprocal of the annual probability of exceedance of a hydrologic event (also return period, exceedance interval).
regime:	The condition of a stream or its channel with regard to stability. A stream is in regime if its channel has reached an equilibrium form as a result of its flow characteristics. Also, the general pattern of variation around a mean condition, as in flow regime, tidal regime, channel regime, sediment regime, etc. (used also to mean a set of physical characteristics of a river).

regime change:	A change in channel characteristics resulting from such things as changes in imposed flows, sediment loads, or slope.
regime channel:	Alluvial channel that has attained, more or less, a state of equilibrium with respect to erosion and deposition.
regime formula:	A formula relating stable alluvial channel dimensions or slope to discharge and sediment characteristics.
reinforced-earth bulkhead:	A retaining structure consisting of vertical panels and attached to reinforcing elements embedded in compacted backfill for supporting a streambank.
reinforced revetment:	A streambank protection method consisting of a continuous stone toe-fill along the base of a bank slope with intermittent fillets of stone placed perpendicular to the toe and extending back into the natural bank.
relief bridge:	An opening in an embankment on a floodplain to permit passage of overbank flow.
retard (retarder structure):	A permeable or impermeable linear structure in a channel parallel with the bank and usually at the toe of the bank, intended to reduce flow velocity, induce deposition, or deflect flow from the bank.
revetment:	Rigid or flexible armor placed to inhibit scour and lateral erosion. (See bank revetment).
riffle:	A natural, shallow flow area extending across a streambed in which the surface of flowing water is broken by waves or ripples. Typically, riffles alternate with pools along the length of a stream channel.
riparian:	Pertaining to anything connected with or adjacent to the banks of a stream (corridor, vegetation, zone, etc.).
riprap:	Layer or facing of rock or broken concrete dumped or placed to protect a structure or embankment from erosion; also the rock or broken concrete suitable for such use. Riprap has also been applied to almost all kinds of armor, including wire-enclosed riprap, grouted riprap, sacked concrete, and concrete slabs.
river training:	Engineering works with or without the construction of embankment, built along a stream or reach of stream to direct or to lead the flow into a prescribed channel. Also, any structure configuration constructed in a stream or placed on, adjacent to, or in the vicinity of a streambank that is intended to deflect currents, induce sediment deposition, induce scour, or in some other way alter the flow and sediment regimes of the stream.
rock-and-wire mattress:	A flat wire cage or basket filled with stone or other suitable material and placed as protection against erosion.

roughness coefficient:	Numerical measure of the frictional resistance to flow in a channel, as in the Manning's or Chezy's formulas.
rubble:	Rough, irregular fragments of materials of random size used to retard erosion. The fragments may consist of broken concrete slabs, masonry, or other suitable refuse.
runoff:	That part of precipitation which appears in surface streams of either perennial or intermittent form.
sack revetment:	Sacks (e.g., burlap, paper, or nylon) filled with mortar, concrete, sand, stone or other available material used as protection against erosion.
saltation load:	Sediment bounced along the streambed by energy and turbulence of flow, and by other moving particles.
sand:	A rock fragment whose diameter is in the range of 0.062 to 2.0 mm.
scour:	Erosion of streambed or bank material due to flowing water; often considered as being localized (see local scour, contraction scour, total scour).
sediment or fluvial sediment:	Fragmental material transported, suspended, or deposited by water.
sediment concentration:	Weight or volume of sediment relative to the quantity of transporting (or suspending) fluid.
sediment discharge:	The quantity of sediment that is carried past any cross section of a stream in a unit of time. Discharge may be limited to certain sizes of sediment or to a specific part of the cross section.
sediment load:	Amount of sediment being moved by a stream.
sediment yield:	The total sediment outflow from a watershed or a drainage area at a point of reference and in a specified time period. This outflow is equal to the sediment discharge from the drainage area.
seepage:	The slow movement of water through small cracks and pores of the bank material.
shear stress:	See unit shear force.
shoal:	A relatively shallow submerged bank or bar in a body of water.
sill:	(a) A structure built under water, across the deep pools of a stream with the aim of changing the depth of the stream; (b) A low structure built across an effluent stream, diversion channel or outlet to reduce flow or prevent flow until the main stream stage reaches the crest of the structure.
silt:	A particle whose diameter is in the range of 0.004 to 0.062 mm.

sinuosity:	The ratio between the thalweg length and the valley length of a stream.
slope (of channel or stream):	Fall per unit length along the channel centerline or thalweg.
slope protection:	Any measure such as riprap, paving, vegetation, revetment, brush or other material intended to protect a slope from erosion, slipping or caving, or to withstand external hydraulic pressure.
sloughing:	Sliding or collapse of overlying material; same ultimate effect as caving, but usually occurs when a bank or an underlying stratum is saturated.
slope-area method:	A method of estimating unmeasured flood discharges in a uniform channel reach using observed high-water levels.
slump:	A sudden slip or collapse of a bank, generally in the vertical direction and confined to a short distance, probably due to the substratum being washed out or having become unable to bear the weight above it.
soil-cement:	A designed mixture of soil and Portland cement compacted at a proper water content to form a blanket or structure that can resist erosion.
sorting:	Progressive reduction of size (or weight) of particles of the sediment load carried down a stream.
spill-through abutment:	A bridge abutment having a fill slope on the streamward side. The term originally referred to the "spill-through" of fill at an open abutment but is now applied to any abutment having such a slope.
spread footing:	A pier or abutment footing that transfers load directly to the earth.
spur:	A permeable or impermeable linear structure that projects into a channel from the bank to alter flow direction, induce deposition, or reduce flow velocity along the bank.
spur dike:	See guide bank.
stability:	A condition of a channel when, though it may change slightly at different times of the year as the result of varying conditions of flow and sediment charge, there is no appreciable change from year to year; that is, accretion balances erosion over the years.
stable channel:	A condition that exists when a stream has a bed slope and cross section which allows its channel to transport the water and sediment delivered from the upstream watershed without aggradation, degradation, or bank erosion (a graded stream).

stage:	Water-surface elevation of a stream with respect to a reference elevation.
stone riprap:	Natural cobbles, boulders, or rock dumped or placed as protection against erosion.
stream:	A body of water that may range in size from a large river to a small rill flowing in a channel. By extension, the term is sometimes applied to a natural channel or drainage course formed by flowing water whether it is occupied by water or not.
streambank erosion:	Removal of soil particles or a mass of particles from a bank surface due primarily to water action. Other factors such as weathering, ice and debris abrasion, chemical reactions, and land use changes may also directly or indirectly lead to bank erosion.
streambank failure:	Sudden collapse of a bank due to an unstable condition such as removal of material at the toe of the bank by scour.
streambank protection:	Any technique used to prevent erosion or failure of a streambank.
suspended sediment discharge:	The quantity of sediment passing through a stream cross section above the bed layer in a unit of time suspended by the turbulence of flow (suspended load).
sub-bed material:	Material underlying that portion of the streambed which is subject to direct action of the flow. Also, substrate.
subcritical, supercritical flow:	Open channel flow conditions with Froude Number less than and greater than unity, respectively.
tetrahedron:	Component of river-training works made of six steel or concrete struts fabricated in the shape of a pyramid.
tetrapod:	Bank protection component of precast concrete consisting of four legs joined at a central joint, with each leg making an angle of 109.5° with the other three.
thalweg:	The line extending down a channel that follows the lowest elevation of the bed.
tieback:	Structure placed between revetment and bank to prevent flanking.
timber or brush mattress:	A revetment made of brush, poles, logs, or lumber interwoven or otherwise lashed together. The completed mattress is then placed on the bank of a stream and weighted with ballast.
toe of bank:	That portion of a stream cross section where the lower bank terminates and the channel bottom or the opposite lower bank begins.

toe protection:	Loose stones laid or dumped at the toe of an embankment, groin, etc., or masonry or concrete wall built at the junction of the bank and the bed in channels or at extremities of hydraulic structures to counteract erosion.
total scour:	The sum of long-term degradation, general (contraction) scour, and local scour.
total sediment load:	The sum of suspended load and bed load or the sum of bed material load and wash load of a stream (total load).
tractive force:	The drag or shear on a streambed or bank caused by passing water which tends to move soil particles along with the streamflow.
trench-fill revetment:	Stone, concrete, or masonry material placed in a trench dug behind and parallel to an eroding streambank. When the erosive action of the stream reaches the trench, the material placed in the trench armors the bank and thus retards further erosion.
turbulence:	Motion of fluids in which local velocities and pressures fluctuate irregularly in a random manner as opposed to laminar flow where all particles of the fluid move in distinct and separate lines.
ultimate scour:	The maximum depth of scour attained for a given flow condition. May require multiple flow events and in cemented or cohesive soils may be achieved over a long time period.
uniform flow:	Flow of constant cross section and velocity through a reach of channel at a given time. Both the energy slope and the water slope are equal to the bed slope under conditions of uniform flow.
unit discharge:	Discharge per unit width (may be average over a cross section, or local at a point).
unit shear force (shear stress):	The force or drag developed at the channel bed by flowing water. For uniform flow, this force is equal to a component of the gravity force acting in a direction parallel to the channel bed on a unit wetted area. Usually in units of stress, Pa (N/m^2) or (lb/ft^2).
unsteady flow:	Flow of variable discharge and velocity through a cross section with respect to time.
upper bank:	The portion of a streambank having an elevation greater than the average water level of the stream.
velocity:	The time rate of flow usually expressed in m/s (ft/sec). The average velocity is the velocity at a given cross section determined by dividing discharge by cross-sectional area.
vertical abutment:	An abutment, usually with wingwalls, that has no fill slope on its streamward side.

vortex:	Turbulent eddy in the flow generally caused by an obstruction such as a bridge pier or abutment (e.g., horseshoe vortex).
wandering channel:	A channel exhibiting a more or less non-systematic process of channel shifting, erosion and deposition, with no definite meanders or braided pattern.
wandering thalweg:	A thalweg whose position in the channel shifts during floods and typically serves as an inset channel that conveys all or most of the stream flow at normal or lower stages.
wash load:	Suspended material of very small size (generally clays and colloids) originating primarily from erosion on the land slopes of the drainage area and present to a negligible degree in the bed itself.
watershed:	See drainage basin.
waterway opening width (area):	Width (area) of bridge opening at (below) a specified stage, measured normal to the principal direction of flow.
weephole:	A hole in an impermeable wall or revetment to relieve the neutral stress or pore pressure in the soil.
windrow revetment:	A row of stone placed landward of the top of an eroding streambank. As the windrow is undercut, the stone is launched downslope, thus armoring the bank.
wire mesh:	Wire woven to form a mesh; where used as an integral part of a countermeasure, openings are of suitable size and shape to enclose rock or broken concrete or to function on fence-like spurs and retards.

(page intentionally left blank)

CHAPTER 1

INTRODUCTION

1.1 PURPOSE

The purpose of this document is to identify and provide design guidelines for bridge scour and stream instability countermeasures that have been implemented by various State departments of transportation (DOTs) in the United States. Countermeasure experience, selection, and design guidance are consolidated from other FHWA publications in this document to support a comprehensive analysis of scour and stream instability problems and provide a range of solutions to those problems. In addition, selected innovative countermeasure concepts and guidance derived from practice outside the United States are introduced.

1.2 BACKGROUND

Scour and stream instability problems have always threatened the safety of our nation's highway bridges. Countermeasures for these problems are defined as measures incorporated into a highway-stream crossing system to monitor, control, inhibit, change, delay, or minimize stream instability and bridge scour problems. A plan of action, which can include timely installation of stream instability and scour countermeasures, should be developed for each scour critical bridge. Monitoring structures during and/or after flood events as a part of a plan of action, can also be considered an appropriate countermeasure.

Numerous measures are available to counteract the actions of humans and nature which contribute to the instability of alluvial streams. These include measures installed in or near the stream to protect highways and bridges by stabilizing a local reach of the stream, and measures which can be incorporated into the highway design to ensure the structural integrity of the highway in an unstable stream environment. Countermeasures include river stabilizing works over a reach of the river up- and downstream of the crossing. Countermeasures may be installed at the time of highway construction or retrofitted to resolve scour and instability problems as they develop at existing crossings. The selection, location, and design of countermeasures are dependent on hydraulic and geomorphic factors that contribute to stream instability, as well as costs and construction and maintenance considerations.

While considerable research has been dedicated to design of countermeasures for scour and stream instability, many countermeasures have evolved through a trial and error process. In addition, some countermeasures have been applied successfully in one locale, state or region, but have failed when installations were attempted under different geomorphic or hydraulic conditions. In some cases, a countermeasure that has been used with success in one state or region is virtually unknown to highway design and maintenance personnel in another state or region. Thus, there is a significant need for information transfer regarding stream instability and bridge scour countermeasure design, installation, and maintenance.

1.3 MANUAL ORGANIZATION

This manual is organized to:

- Provide management strategies for developing a Plan of Action for a scour critical bridge (Chapter 2)

- Highlight the various groups of countermeasures and identify their individual characteristics (Chapter 2)
- For a wide-range of countermeasures, list information on their functional applicability to a particular problem, their suitability to specific river environments, the general level of maintenance resources required, and which DOTs have experience with specific countermeasures (Chapter 2 and the Countermeasures Matrix).
- Provide general criteria for selection of countermeasures for bridge scour and stream instability problems (Chapter 3)
- Discuss countermeasure design concepts including design approach, hydraulic analysis, environmental permitting, special design considerations related to riprap, filters, and edge treatment, and biotechnical engineering approaches (Chapter 4).
- Provide detailed design guidelines for specific bridge scour and stream instability countermeasures (Chapter 5 and Design Guidelines 1 through 12).
- Summarize general guidance for other countermeasures and case histories of countermeasure performance (Chapter 6).
- Provide criteria for selecting portable and fixed instrumentation for monitoring scour at bridges (Chapter 7).

1.4 COMPREHENSIVE ANALYSIS

This manual is part of a set of Hydraulic Engineering Circulars (HEC) issued to provide guidance for bridge scour and stream stability analyses. The three manuals in this set are:

- HEC-18 Evaluating Scour at Bridges
- HEC-20 Stream Stability at Highway Structures
- HEC-23 Bridge Scour and Stream Instability Countermeasures

The Flow Chart shown in Figure 1.1 illustrates the interrelationship between these three documents and emphasizes that they should be used as a set. A comprehensive scour analysis or stability evaluation must be based on information presented in all three documents.

While the flow chart does not attempt to present every detail of a complete stream stability and scour evaluation, it has sufficient detail to show the major elements in a complete analysis, the logical flow of a typical analysis or evaluation, and the most common decision points and feedback loops. It clearly shows how the three documents tie together, and recognizes the differences between design of a new bridge and evaluation of an existing bridge.

The HEC-20 block of the flow chart outlines initial data collection and site reconnaissance activities leading to an understanding of the problem, evaluation of river system stability and potential future response. The HEC-20 procedures include both qualitative and quantitative geomorphic and engineering analysis techniques which help establish the level of analysis necessary to solve the stream instability and scour problem for design of a new bridge, or for the evaluation of an existing bridge that may require rehabilitation or countermeasures. The "Classify Stream," "Evaluate Stream Stability," and "Assess Stream Response" portions of the HEC-20 block are expanded in HEC-20 into a six-step Level 1 and an eight-step Level 2 analysis procedure. In some cases, the HEC-20 analysis may be sufficient to determine that stream instability and/or scour problems do not exist, i.e., the bridge has a "low risk of failure" regarding scour susceptibility.

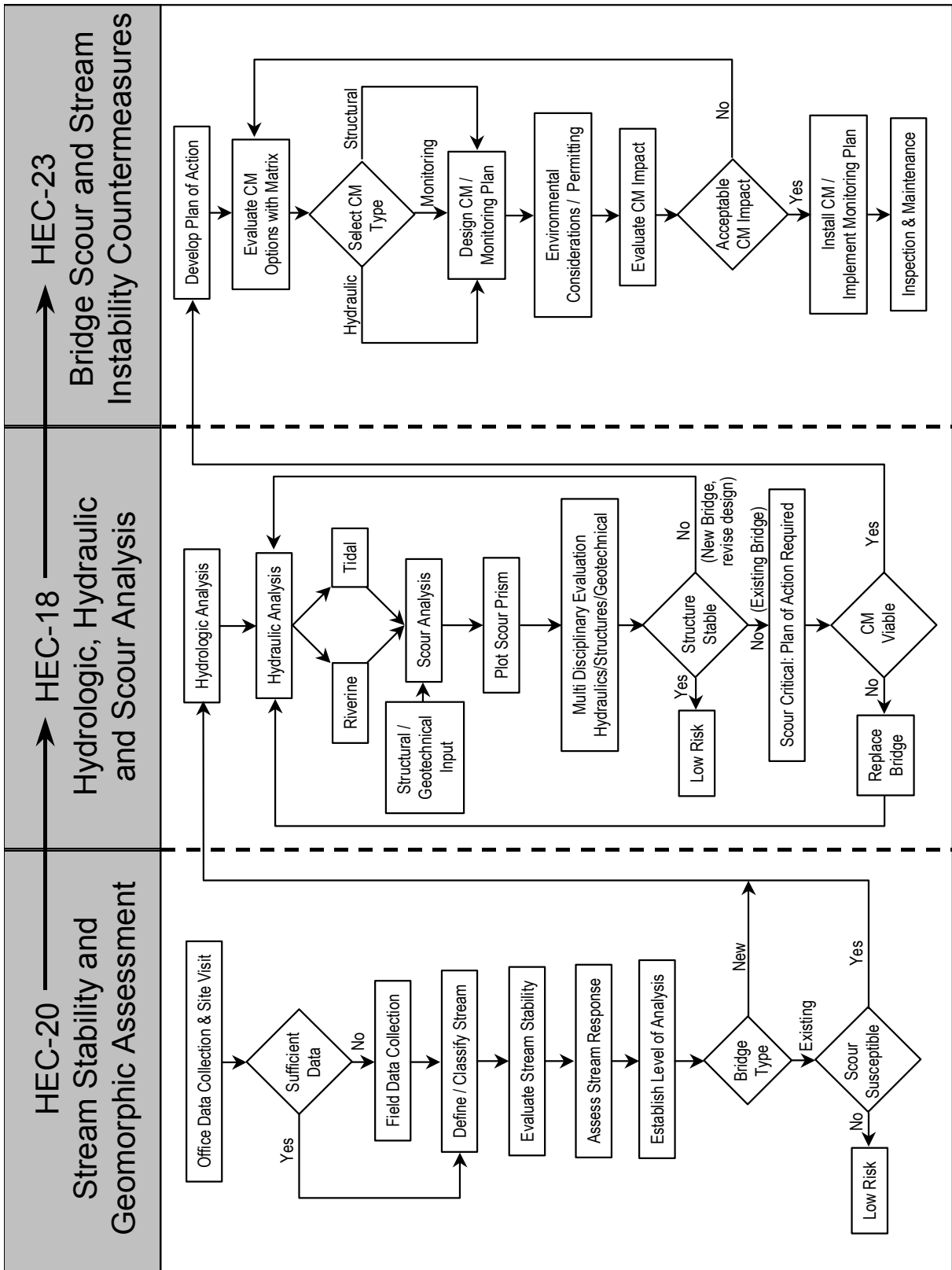

Figure 1.1. Flow chart for scour and stream stability analysis and evaluation.

In most cases, the analysis or evaluation will progress to the HEC-18 block of the flow chart. Here more detailed hydrologic and hydraulic data are developed, with the specific approach determined by the level of complexity of the problem and waterway characteristics (e.g., tidal or riverine). The "Scour Analysis" portion of the HEC-18 block encompasses a seven-step specific design approach which includes evaluation of the components of total scour.

Since bridge scour evaluation requires multidisciplinary inputs, it is often advisable for the hydraulic engineer to involve structural and geotechnical engineers at this stage of the analysis. **Once the total scour prism is plotted, then all three disciplines must be involved in a determination of the structural stability of the bridge foundation.**

For a new bridge design, if the structure is stable the design process can proceed to consideration of environmental impacts, cost, constructability, and maintainability or if the bridge is unstable, revise the design and repeat the analysis. For an existing bridge, a finding of structural stability at this stage will result in a "low risk" evaluation, with no further action required. However, a Plan of Action should be developed for an unstable existing bridge (scour critical) to correct the problem as outlined in Sections 1.5 and 2.1.

The scour problem may be so serious that installing countermeasures would not provide a viable solution and a replacement or substantial bridge rehabilitation would be required. If countermeasures would correct the stream instability or scour problem at a reasonable cost and with acceptable environmental impacts, the analysis would progress to the HEC-23 block of the flow chart.

Hydraulic Engineering Circular 23 provides a range of resources to support bridge scour and stream instability countermeasure selection and design. A countermeasure matrix (Chapter 2) presents a variety of countermeasures that have been used to control scour and stream instability at bridges.

HEC-23 also includes specific Design Guidelines for the most common (and some uncommon) countermeasures used by DOTs, or references to sources of design guidance. Inherent in the design of any countermeasure are an evaluation of potential environmental impacts, permitting for countermeasure installation, and redesign, if necessary, to meet environmental requirements. As shown in the flow chart, to be effective most countermeasures will require a monitoring plan, inspection, and maintenance.

1.5 PLAN OF ACTION

Each bridge identified as scour critical in Item 113 of the National Bridge Inspection Standards should have a plan of action describing what will be done to address the scour problem. The plan of action should include a monitoring program and a schedule for the timely design and construction of hydraulic or structural countermeasures, if any are warranted. The purpose of the plan of action is to provide for the safety of the traveling public, and to minimize the potential for bridge failure, by prescribing site-specific actions that will be taken at the bridge to correct the scour problem. The actions (or countermeasures) taken can be categorized as hydraulic countermeasures, structural countermeasures, or a monitoring program (see Chapter 2).

Hydraulic countermeasures are primarily designed to modify the stream flow or resist erosive forces. Examples of hydraulic countermeasures include the installation of river training structures and the placement of riprap at piers or abutments (Lagasse et al. 1997b).

Structural countermeasures usually involve modification of the bridge substructure to increase bridge stability. Typical structural countermeasures are underpinning and pier modification.

A properly designed scour monitoring program as part of the plan of action includes two primary components:

1. The frequency and type of measurements to facilitate early identification of potential scour problems, and
2. Specific instructions describing precisely what must be done if a bridge is at risk due to scour.

Note that a monitoring program involves more than just instrumentation. It must describe specific actions to be taken once a scour problem has been identified. In some cases, a properly designed scour monitoring program can be an acceptable countermeasure by itself. However, monitoring does not fix the scour problem, and therefore, does not allow changing the Item 113 coding on a scour-critical bridge. In other cases, a monitoring program allows time to implement hydraulic or structural countermeasures. Information in Section 2.1 outlines how to develop a plan of action for a scour critical bridge, and provides specific strategies for deciding when and how to implement a monitoring program.

1.6 DUAL SYSTEM OF UNITS

This edition of HEC-23 uses dual units (SI metric and English). The "English" system of units as used throughout this manual refers to U.S. Customary units. **In Appendix A, the metric (SI) unit of measurement is explained. The conversion factors, physical properties of water in the SI and English systems of units, sediment particle size grade scale, and some common equivalent hydraulic units are also given.** This edition uses for the unit of length the meter (m) or foot (ft); of mass the kilogram (kg) or slug; of weight/force the newton (N) or pound (lb); of pressure the Pascal (Pa, N/m²) or (lb/ft²); and of temperature the degree Centigrade (°C) or Fahrenheit (°F). The unit of time is the same in SI as in English system (seconds, s). Sediment particle size is given in millimeters (mm), but in calculations the decimal equivalent of millimeters in meters is used (1 mm = 0.001 m) or for the English system feet (ft). The value of some hydraulic engineering terms used in the text in SI units and their equivalent English units are given in Table 1.1.

Table 1.1. Commonly Used Engineering Terms in SI and English Units.		
Term	SI Units	English Units
Length	1 m	3.28 ft
Volume	1 m ³	35.31 ft ³
Discharge	1 m ³ /s	35.31 ft ³ /s
Acceleration of Gravity	9.81 m/s ²	32.2 ft/s ²
Unit Weight of Water	9800 N/m ³	62.4 lb/ft ³
Density of Water	1000 kg/m ³	1.94 slugs/ft ³
Density of Quartz	2647 kg/m ³	5.14 slugs/ft ³
Specific Gravity of Quartz	2.65	2.65
Specific Gravity of Water	1	1
Temperature	°C = 5/9 (°F - 32)	°F

(page intentionally left blank)

CHAPTER 2

PLAN OF ACTION AND THE COUNTERMEASURES MATRIX

2.1 STRATEGIES FOR PROTECTING SCOUR CRITICAL BRIDGES

2.1.1 Technical Advisories

The National Bridge Inspection Standards (23 CFR 650, Subpart C) requires bridge owners to maintain a bridge inspection program that includes procedures for underwater inspection. A national scour evaluation program as an integral part of the National Bridge Inspection standards was established in 1988 by Technical Advisory T5140.20.

Technical Advisory T5140.20 was superceded in 1991 by Technical Advisory T 5140.23, to provide more guidance on the development and implementation of procedures for evaluating bridge scour to meet the requirements of 23 CFR 650, Subpart C. Specifically, Technical Advisory T5140.23 provides guidance on:

1. Developing and implementing a scour evaluation for designing new bridges
2. Evaluating existing bridges for scour vulnerability
3. Using scour countermeasures
4. Improving the state-of-practice for estimating scour at bridges.

The Technical Advisory suggests that scour evaluations of both new and existing bridges should be conducted by an interdisciplinary team comprised of hydraulic, geotechnical and structural engineers. The recommendation for new bridges is to design the bridge foundation for potential scour by assuming that all streambed material in the computed scour prism has been removed and is not available for bearing or lateral support. Bridge foundations should be designed to withstand scour during floods equal to or less than the 100-year flood, and should be checked to ensure they will not fail during a superflood (on the order of the 500-year event). The procedures for computing the scour prism, which represents calculated scour conditions, are detailed in HEC-18.

The recommendation for existing bridges is to evaluate every bridge over a waterway for scour to determine if it is scour critical or low risk. For a scour critical bridge, prudent measures should be taken for its protection. A scour critical bridge is one with abutment or pier foundations that are rated as unstable due to (1) observed scour at the bridge site, or (2) scour potential as determined from a scour evaluation study. A bridge that is not scour critical was defined as low risk, generally considered to have little potential for scour or stream instability problems. Results of the scour evaluation study for existing bridges are coded in Item 113 of the 1995 Recording and Coding Guide for the Structure Inventory and Appraisal of the Nations Bridges - FHWA Report PD-96-001 (more commonly known as the Coding Guide). Descriptions of Item 113 codes are currently being updated and will be implemented in the 2001 edition of the Coding Guide.

Technical Advisory T 5140.23 specifies that a plan of action should be developed for each existing bridge found to be scour critical. The two primary components of the plan of action are instructions regarding the type and frequency of inspections to be made at the bridge, and a schedule for the timely design and construction of scour countermeasures. The Technical Advisory further recommends appropriate training and instruction for bridge

inspectors in scour issues. These include issues such as collection and comparison of cross section data, identification of conditions indicative of potential scour problems, and effective notification procedures when an actual or potential problem is identified at or in the vicinity of the bridge.

Information in this chapter provides direction for developing a plan of action. Issues related to the type and frequency of inspections are described first, followed by the range of scour countermeasures available that could be incorporated in the plan of action. The countermeasures matrix is introduced, which provides a concise summary of the available countermeasures in categories classified as hydraulic, structural and monitoring. The remainder of HEC-23 details the various scour countermeasures available in each category, which might be implemented through a plan of action.

2.1.2 Management Strategies for a Plan of Action

As described above, when a bridge is found to be scour critical, either by inspection or by calculation, a plan of action should be developed and implemented for that bridge. While many bridges may be found to be scour critical, the severity of the problem and the risk involved to the traveling public can vary dramatically. As a result, the management strategy for the plan of action, including factors such as the urgency of the response, the type and frequency of the inspection work, the redundancy in the plan, and amount of money and resources allocated to countermeasures (including monitoring), can vary from one scour critical bridge to the next.

For example, a bridge found to be scour critical by inspection, such as during an underwater inspection that finds a substantial scour hole undermining the foundation, would obviously be a greater concern than a bridge that is currently stable, but rated scour critical based on calculations of conditions that might develop during the 100-year flood. In the first case, the bridge has already experienced scour and is at risk of failure, whereas in the second case the bridge is not presently at risk, but might develop a scour problem in the future when it is subjected to the 100-year flood. The resulting management strategy for developing and implementing the plan of action would be much more urgent in the first case.

The management strategy may also vary according to the importance of the roadway to the transportation network and may require a risk-based analysis. For example, a bridge with high average daily traffic (ADT), or one that provides the only access in and out of a given area would be a greater concern than a low ADT bridge, or one for which alternate routes or detours were available. Similarly, a bridge that provides access for a hospital or fire station would be very important and might justify more resources or concern in developing and implementing a plan of action. A bridge that is along an evacuation route or provides access to an airport might also require a different level of response in developing a plan of action.

The management strategy might vary as a result of other repair or replacement plans. For example, a bridge found to be scour critical but already programmed for replacement in the near future might be treated differently from another bridge that was newer, or not considered for replacement for many years. In the first case, the use of monitoring as a countermeasure until replacement can occur might be reasonable, whereas in the second case, a structural countermeasure, at substantially greater cost, would probably be necessary.

Updates to Item 113 codes will allow bridge owners to consider countermeasures when coding a bridge as stable, low risk, or scour critical, based on the results of a bridge inspection and/or a scour evaluation. Hydraulic or structural countermeasures that have been selected and designed by the interdisciplinary team, and properly installed can change a scour critical coding under Item 113 of the updated coding guide. Also, the updates will allow bridge owners to consider mitigation measures installed during and/or immediately after a flood event in determining the appropriate Item 113 code. For this case, a plan of action must include specific instructions for monitoring the countermeasures to reduce the risk to the public users from a bridge failure. For additional information, see HEC-18, Chapters 10, 11, and 12, and Appendix I.

2.1.3 Inspection Strategies in a Plan of Action

The type and frequency of inspection work called for in the plan of action can also vary dramatically based on the management strategy. Bridges that are more important, or at higher risk, may justify more intense inspection efforts. Factors such as when to begin the inspection work, how often to visit the bridge during a flood, and when monitoring is no longer necessary must be addressed in the plan of action.

If a bridge foundation is determined to be unstable for the assessed or calculated stream stability or scour condition, and field inspection shows no evidence of a scour problem, the inspection requirements may not be any more than those required by the National Bridge Inspection Standards (NBIS). For example, a bridge that is rated scour critical by calculations, but has a relatively deep piles in an erosion-resistant material and has been in place for many years with no sign of scour, might adequately be addressed through the regular inspection cycle and after major flood events.

If more frequent inspections are required, the plan of action needs to describe when to begin monitoring efforts. Initiation of inspection work can be based on discharge or stage measurements. While discharge is used to define or analyze scour conditions (e.g. scour during the 100-year flood), it is typically not the best criteria for triggering flood monitoring and inspection work. The primary limitation of a discharge based criteria is that the inspector often does not have a way of determining the discharge in the river, such as gaging station or flood forecasting results.

A more viable approach to define when to begin scour measurements has been to use the stage data corresponding to a critical discharge condition. However, even stage data must be specified in a manner that is easily understood and measurable by bridge inspection crews. For example, defining the initiation of scour measurements based on flood stage is only practical if stage information is readily available, and/or a gaging station is located at or near the bridge. Alternatively, if the critical water surface elevation is defined based on the distance from the guard rail or curb line of the bridge, the inspector can readily measure that distance and know when to begin data collection. An even more direct approach is to mark a line on a pier or abutment that defines when data collection or monitoring should be initiated.

On a basin wide basis, it may be possible to define flood watch requirements based on flood forecasting information. A simplistic approach is to implement monitoring after a given amount of rain has occurred. For example, the criteria might be to begin monitoring after a cumulative rainfall of 40 cm (10 inches) in 24 hours. A general criteria such as this might require the bridge inspection crews to immediately begin monitoring all scour critical bridges in that basin. Alternatively, in a more instrumented watershed with extensive flood warning

systems, the use of GIS data and flood forecasting models could define in advance which bridges will need to be monitored at what times during the flood.

Once the flood inspection program is underway, the inspector needs to know exactly what constitutes a critical scour condition, and what to do when this condition has been detected. Specifically, a scour critical elevation should be defined in the plan of action for each pier or abutment to be monitored. Information on who to call and what action to take once that elevation has been reached should also be detailed in the plan of action. This could extend as far as discussion of emergency repair measures and/or bridge closure directions.

2.1.4 Closure Instructions

Closure instructions can range from load restrictions, lane closures or complete bridge closure, again depending on the severity of the problem and the risk involved. The method of closure should also be described. In some cases barricades may be adequate, while in other cases it may require, or justify based on the risk involved, the posting of a law enforcement officer at the bridge to insure that no one attempts to cross the structure. The availability and description of detour routes should be included in the plan of action, so when a bridge is closed an alternative route has already been defined to minimize traffic disruption. The scour vulnerability of bridges along the detour route should be known and evaluated in developing detour alternatives.

Instructions on the criteria for re-opening the bridge or traffic lane, or removing the load restriction, should also be provided. In many cases, the act of closing is easier than re-opening. Virtually anyone who detects a problem, such as an inspector, law enforcement officer, or bridge owner could make the decision to close a bridge, but the decision about when it is safe to re-open may require more information and engineering analysis by the interdisciplinary team. The person authorized to make the decision to re-open should be identified in the plan of action.

2.1.5 Countermeasure Alternatives and Schedule

The two primary components of the plan of action are instructions regarding the type and frequency of inspections to be made at the bridge, and a schedule for the timely design and construction of scour countermeasures. Developing a schedule for the timely construction of countermeasures first requires defining the preferred countermeasure alternative. It is typical that several different alternatives might be appropriate countermeasures for a given scour or stream stability problem at a bridge. A comprehensive plan of action should provide enough information that an independent reviewer could arrive at the same conclusion regarding the preferred alternative.

In order to evaluate alternatives a conceptual design should be developed for various alternatives. This facilitates evaluation of the engineering feasibility of the alternative, and allows developing preliminary cost estimates. The various alternatives developed should be presented in the plan of action, and a narrative provided describing why the preferred alternative was chosen.

Once the preferred alternative is selected, a schedule should be developed for the timely design and construction of the preferred alternative. It may be that a more intense

monitoring alternative is recommended as a measure to reduce the risk from scour, prior to design and construction of countermeasures to make the bridge safe from scour.

2.1.6 Other Information Necessary In a Plan of Action

The plan of action can include other information to the inspector, including special conditions to watch for such as debris build-up and associated problems. It might include instructions on communications with the media, such as who is authorized to make statements and what information should be provided. Actions such as bridge closures and/or bridge failures generate a lot of interest and concern from both the media and the public. Developing a communications plan ahead of time can minimize confusion and mis-communication. The plan of action might also describe emergency action countermeasures, such as what type of riprap is adequate, local sources, and installation methods during a flood situation.

2.1.7 Identifying Countermeasures for the Plan of Action

As suggested by the various scenarios already described, a risk-based analysis may be necessary to develop the plan of action for multiple bridges with scour critical ratings. The level of response and the actions taken will be different from one scour critical bridge to the next. Given limited resources and multiple options, it is up to the interdisciplinary team to formulate the best alternative for any given plan of action considering all available information.

Selecting the countermeasures to be included in the plan of action requires evaluating a number of alternatives. These alternatives could include hydraulic countermeasures, structural countermeasures or monitoring, either individually or in some combination. To facilitate selection of alternatives to be considered in the plan of action, a matrix describing the various countermeasures and their attributes has been developed. This countermeasure matrix is introduced and described in the next section.

2.2 OVERVIEW OF THE MATRIX

A wide variety of countermeasures have been used to control channel instability and scour at bridge foundations. The countermeasure matrix, presented in Table 2.1, is organized to highlight the various groups of countermeasures and to identify their individual characteristics. The left column of the matrix lists types of countermeasures in groups. In each row of the matrix, distinctive characteristics of a particular countermeasure are identified. The matrix identifies most countermeasures used by DOTs and lists information on their functional applicability to a particular problem, their suitability to specific river environments, the general level of maintenance resources required, and which states have experience with specific countermeasures. Finally, a reference source for design guidelines is noted, where available.

Countermeasures have been organized into groups based on their functionality with respect to scour and stream instability. The three main groups of countermeasures are: **hydraulic countermeasures**, **structural countermeasures** and **monitoring**. The following outline identifies the countermeasure groups in the matrix:

Group 1. Hydraulic Countermeasures

- Group 1.A: River training structures
 - Transverse structures
 - Longitudinal structures
 - Areal structures
- Group 1.B: Armoring countermeasures
 - Revetment and Bed Armor
 - + Rigid
 - + Flexible/articulating
 - Local armoring

Group 2. Structural Countermeasures

- Foundation strengthening
- Pier geometry modification

Group 3. Monitoring

- Fixed Instrumentation
- Portable instrumentation
- Visual Monitoring

2.3 COUNTERMEASURE GROUPS

2.3.1 Group 1. Hydraulic Countermeasures

Hydraulic countermeasures are those which are primarily designed either to modify the flow or resist erosive forces caused by the flow. Hydraulic countermeasures are organized into two groups: **river training structures and armoring countermeasures**. The performance of hydraulic countermeasures is dependent on design considerations such as filter requirements and edge treatment, which are discussed in Sections 4.5 and 4.6, respectively.

Group 1.A River Training Structures. River training structures are those which modify the flow. River training structures are distinctive in that they alter hydraulics to mitigate undesirable erosional and/or depositional conditions at a particular location or in a river reach. River training structures can be constructed of various material types and are not distinguished by their construction material, but rather, by their orientation to flow. River training structures are described as **transverse**, **longitudinal** or **areal** depending on their orientation to the stream flow.

- **Transverse river training structures** are countermeasures which project into the flow field at an angle or perpendicular to the direction of flow.
- **Longitudinal river training structures** are countermeasures which are oriented parallel to the flow field or along a bankline.

Table 2.1 STREAM INSTABILITY AND BRIDGE SCOUR COUNTERMEASURES MATRIX.

Countermeasure Group	Countermeasure Characteristics										DESIGN GUIDELINE REFERENCE*			
	FUNCTIONAL APPLICATIONS					SUITABLE RIVER ENVIRONMENT						MAINTENANCE	INSTALLATION EXPERIENCE BY STATE	
	Local Scour	Contraction Scour	Stream Instability	River Type	Stream Size	Bank Radius	Velocity	Bed Material	Ice/Debris Load	Bank Condition				Floodplain
Abutments Piers	Floodplain and Channel	Vertical Lateral	B = braided M = meandering S = straight	W = wide M = moderate S = small	L = long M = moderate S = short	F = fast M = moderate S = slow	C = coarse bed S = sand bed F = fine bed	H = high M = moderate L = low	V = vertical S = steep F = flat	N = wide M = moderate N = narrow/none	H = high M = moderate L = low			
GROUP 1.0. HYDRAULIC COUNTERMEASURES														
GROUP 1.A. RIVER TRAINING STRUCTURES														
TRANSVERSE STRUCTURES														
Impermeable spurs (tetties, groins, wing dams)	●	○	○	B, M	W, M	L, M	✓	✓	✓	✓	✓	M - L	Widely Used	DG9, 1, 4
Permeable spurs (fences, netting)	●	○	○	B, M	W, M	L, M	✓	✓	✓	✓	✓	H - M	Widely Used	DG9, 1, 2, 4
Transverse dikes	○	○	○	B, M	W, M	✓	✓	✓	✓	✓	✓	M - L	NE	DG1
Bendway weirs/Stream baffles ¹	●	○	○	M	✓	M, S	✓	✓	✓	✓	✓	L	CO, ID, IL, MO, MT, OR, WA	DG1
Hardpoints	○	○	○	✓	✓	✓	✓	✓	✓	✓	✓	L	CA, ND, NE, SD	CH6, 1, 4, 5
Drop structures (check dams, grade control)	○	○	○	✓	✓	✓	✓	✓	✓	✓	✓	M	Widely Used	DG11, 4
Embankment Spurs	○	○	○	✓	✓	✓	✓	✓	✓	✓	✓	L	AK, OK	12
LONGITUDINAL STRUCTURES														
Longitudinal dikes (crib/rock toe/embankments)	○	○	○	✓	✓	L, M	✓	✓	✓	✓	✓	M - L	AK, AZ, CA, OR, MS	CH6, 2, 4
Retards	○	○	○	✓	✓	L, M	✓	✓	✓	✓	✓	H - M	Widely Used	CH6, 2, 4
Bulkheads	○	○	○	✓	✓	✓	✓	✓	✓	V, S	✓	M	Widely Used	CH6, 2, 4
Guide banks	○	○	○	✓	✓	✓	✓	✓	✓	✓	✓	M - L	Widely Used	DG10, 4, 5
AREAL STRUCTURES/TREATMENTS														
Jackstruttedon jetty fields	○	○	○	B, M	W, M	L	M, S	✓	✓	✓	✓	M	L, MS, MS, NM, OK, SD, TX	CH6, 1, 2, 4
Vanes	○	○	○	B, M	W, M	L, M	M, S	✓	✓	✓	✓	H - M	IA	6, 14
Channelization	○	○	○	B, M	✓	✓	✓	✓	✓	✓	✓	M	MS, MO, MT, TX	CH6
Flow relief (overflow, relief bridge)	○	○	○	✓	✓	✓	✓	✓	✓	✓	✓	M	Widely Used	
Sediment detention basin	○	○	○	✓	✓	✓	✓	✓	✓	C, S	✓	H - M	Widely Used	
GROUP 1.B. ARMORING COUNTERMEASURES														
REVETMENTS AND BED ARMOR														
Rigid														
Soil cement	●	●	●	✓	✓	✓	✓	✓	✓	✓	✓	L	AZ, CO, NM	DG2, 4
Concrete pavement	●	●	●	✓	✓	✓	✓	✓	✓	S, F	✓	M	Widely Used	2, 3
Rigid grout filled mattress/concrete fabric mat	●	●	●	✓	✓	✓	✓	✓	✓	S, F	✓	M	GA, MA, MD, ME, SD, WA	15
Grouted riprap	●	○	○	✓	✓	✓	✓	✓	✓	S, F	✓	M	AZ, CA, CT, ME, MI, TN	2, 3
Flexible/articulating														
Riprap	○	○	○	✓	✓	✓	✓	✓	✓	S, F	✓	M	Widely Used	DG12, 2, 3, 4
Self launching riprap (windrow)	○	○	○	✓	✓	✓	✓	✓	✓	C, S	✓	H - M	GA, CA, IL, PA	DG12, 2, 4, 6
Riprap fill-trench	○	○	○	✓	✓	✓	✓	✓	✓	✓	✓	M	Widely Used	DG12, 2, 3, 4
Gabions/gabion mattress ²	○	○	○	✓	✓	✓	✓	✓	✓	S, F	✓	M	Widely Used	2, 3, 4, 5, 18
Wire enclosed riprap mattress (rail bank/sausage)	○	○	○	✓	✓	✓	M, S	✓	✓	S, F	✓	M	AZ, CO, NM	DG3, 7
Articulated blocks (interlocking and/or cable tied)	○	○	○	✓	✓	✓	✓	✓	✓	S, F	✓	M - L	AZ, CA, FL, MI, MN, OH, ME, TX	DG4, 2, 3, 8, 9, 10, 17
Concrete/grout mattress (fabric-formed)	○	○	○	✓	✓	✓	✓	✓	✓	S, F	✓	M - L	OR, CA, IL, AZ	DG5, 15
LOCAL SCOUR ARMORING														
Riprap (fill/apron)	●	N/A	N/A	✓	✓	✓	✓	✓	✓	S, F	✓	H - M	Widely Used	DG8, 4
Grouted riprap	○	N/A	N/A	✓	✓	✓	✓	✓	✓	S, F	✓	H - M	Widely Used	3
Concrete armor units (Toshianes, tetrapods, etc.) ³	●	N/A	N/A	✓	✓	✓	✓	✓	✓	S, F	✓	M - L	AZ, PA, NY, VA	DG6, 19, 21
Grout filled bags/sand cement bags	●	N/A	N/A	✓	✓	✓	✓	✓	✓	S, F	✓	H - M	Widely Used	DG7, 2, 4, 7, 21
Gabions	●	N/A	N/A	✓	✓	✓	✓	✓	✓	S, F	✓	M	FL, WA, TN, OR	
Articulated blocks (interlocking and/or cable tied)	●	N/A	N/A	✓	✓	✓	✓	✓	✓	S, F	✓	M - L	AZ, CA, FL, MI, MN, OH, ME, TX	DG4, 11, 21
Sheet pile/cofferdam	●	N/A	N/A	✓	✓	✓	✓	✓	✓	S, F	✓	M - L	CA, CT, FL, NH, WA	2, 3, 4, 5

● well suited/primary use
 ● possible application/secondary use
 ○ unsuitable/rarely used
 N/A not applicable

✓ suitable for the full range of the characteristic

DG# design guideline attached
 CH# HEC-23 chapter

*see Chapter 6 for complete reference list

(page intentionally left blank)

Table 2.1 STREAM INSTABILITY AND BRIDGE SCOUR COUNTERMEASURES MATRIX (continued).

Countermeasure Group	Countermeasure Characteristics												DESIGN GUIDELINE REFERENCE*	
	FUNCTIONAL APPLICATIONS			SUITABLE RIVER ENVIRONMENT				MAINTENANCE		INSTALLATION EXPERIENCE BY STATE				
	Local Scour	Contraction Scour	Stream instability	River Type	Stream Size	Bend Radius	Velocity	Bed Material	Ice/Debris Load		Bank Condition	Floodplain		Estimated Allocation of Resources
Abutments Piers	Floodplain and Channel	Vertical Lateral	St. braided M = meandering S = straight	Nr. wide M = moderate S = small	L = long M = moderate S = short	F = fast M = moderate S = slow	C = coarse bed S = sand/cast F = fine bed	H = high M = moderate L = low	V = vertical S = steep F = fill	Nr. wide M = moderate S = narrow/none	H = high M = moderate L = low			
GROUP 2. STRUCTURAL COUNTERMEASURES														
FOUNDATION STRENGTHENING														
Catch basins/Underpinning	●	●	●	✓	✓	✓	✓	✓	✓	✓	✓	L	FL, NC, OR, TX	
Cross bracing	●	●	○	✓	✓	✓	✓	✓	✓	✓	✓	L	NC, FL, LA	
Continuous spans	○	●	○	✓	✓	✓	✓	✓	✓	✓	✓	L	NC	
Pumped concrete/grout under footing	●	●	●	✓	✓	✓	✓	✓	✓	✓	✓	M	GA, MD, ME, MN, NC, NY, OR	DC7
Lower foundation	●	●	●	✓	✓	✓	✓	✓	✓	✓	✓	L	CA, OR, TX	
PIER GEOMETRY MODIFICATION														
Extended footings	N/A	N/A	N/A	✓	✓	✓	✓	✓	✓	✓	✓	L	AK, AZ, NV, PA, TN, TX, WA	21
Pier shape modifications	N/A	N/A	N/A	✓	✓	✓	✓	✓	✓	✓	✓	M	FL	
Debris deflectors	N/A	N/A	N/A	✓	✓	✓	✓	✓	✓	✓	✓	H - M	CA, FL, NM, OR	20, 22
Sacrificial piles/dolphins	N/A	N/A	N/A	✓	✓	✓	✓	✓	✓	✓	✓	H - M		
GROUP 3. MONITORING														
FIXED INSTRUMENTATION														
Sonar scour monitor	●	●	●	✓	✓	✓	✓	✓	✓	✓	✓	M	CO, FL, IN, NY, VA, TX	CH7, 13, 16
Magnetic sliding collar	●	●	●	✓	✓	✓	✓	S, F	✓	✓	✓	M	CO, FL, IN, MI, MN, NM, NY, TX	CH7, 13, 16
Floot out device	●	●	●	✓	✓	✓	✓	S, F	✓	✓	✓	L	AZ, CA, NV	CH7
Sounding rods	●	●	●	✓	✓	✓	✓	C	✓	✓	✓	H	AR, IA, NY	CH7, 13, 16
PORTABLE INSTRUMENTATION														
Physical probes	●	●	●	✓	✓	✓	✓	✓	✓	✓	✓	L	Widely Used	13, 16
Sonar probes	●	●	●	✓	✓	✓	✓	✓	✓	✓	✓	L	Widely Used	13, 16
VISUAL MONITORING														
Periodic inspection	●	●	●	✓	✓	✓	✓	✓	✓	✓	✓	H	Widely Used	13, 16
Flood watch	●	●	●	✓	✓	✓	✓	✓	✓	✓	✓	H	Widely Used	13, 16

well suited/primary use
possible application/secondary use
unsuitable/rarely used
N/A not applicable

✓ suitable for the full range of the characteristic

DG# design guideline attached
CH# HEC-23 chapter

*see Chapter 8 for complete reference list

NOTES:
1. There is limited but successful field experience using bendway weirs/stream bars as stream instability countermeasures.
2. Performance of welded versus twisted wire and PVC coated versus uncoated wire gabions is not distinguished in the matrix.
3. There is limited field experience using concrete armor units as protection for bridge piers.

REFERENCES (numbers represent those in design guideline reference column)

- BROWN1: Brown, S.A., 1965. "Design of Typical Scour Protection Structures." FHWA/RD-84/101, FHWA, Washington, D.C.
- BROWN2: Brown, S.A., 1965. "Scour Protection Measures for Highway Engineers." FHWA/RD-84/100, FHWA, Washington, D.C.
- HEC-11: Brown, S.A., E.S. Clyde, 1989. "Design of Riprap Retention." Hydraulic Engineering Circular No. 11, FHWA-P-016, prepared for FHWA, Washington, D.C.
- HIRE: Richardson, E.V., D.B. Simons, P.F. Lagasse, 2001. "Highways in the River Environment." HDS-6, FHWA, Washington, D.C.
- HDS-4: Bradley, J.N., 1978. "Hydraulics of Bridge Waterways." Hydraulic Design Series No. 1, U.S. Department of Transportation, FHWA.
- USCOE: U.S. Army Corps of Engineers, 1981. "The Streambank Erosion Control Evaluation and Demonstration Act of 1974." Final Report to Congress, Executive Summary and Conclusions
- KEOWN: Keown, M.P., 1983. "Streambank Protection Guidelines for Landowners and Local Governments." U.S. Army Corps of Engineers, Waterways Experiment Station, Vicksburg, Mississippi
- CLOPPER1: Clopper, P.E., 1989. "Hydraulic Stability of Articulated Concrete Block Revetment Systems During Overtopping Flow." FHWA-RD-89-199, Office of Engineering and Highway Operations R&D, McLean VA.
- CLOPPER2: Clopper, P.E., Y. Chen, 1998. "Minimizing Embankment Damage During Overtopping Flow." FHWA-RD-88-181, Office of Engineering and Highway Operations R&D, McLean VA.
- McCORQUODALE1: McCorquodale, J.A., 1991. "Guide for the Design and Placement of Cable Concrete Mats." Report Prepared for the Manufacturers of Cable Concrete.
- 11 McCORQUODALE2: McCorquodale, J.A., 1993. "Cable-tied Concrete Block Erosion Protection." Hydraulic Engineering 93, San Francisco, CA, Proceedings (1993), pp. 1367-1372
- BRICE & BLODGETT: Brice, J.C., Blodgett, J.C., 1978. "Countermeasure for Hydraulic Problems at Bridges, Volumes 1 and 2." FHWA-RD-78-162 and 163, US95, Menlo Park, CA.
- DP-97: Scour Monitoring and Instrumentation, Demonstration Project 97, Participants Workbook (November 1995)
- ODGAARD: Odgaard, A.J. and Wang, Y., "Seelment Management with Submerged Vans, 1 and II." Journal of Hydraulic Engineering, ASCE Vol. 117, 3 (1991a and b) pp. 267-283 and 284-302.
- KARIM: Karim, M., 1975. "Concrete Fabric Mat." Highway Focus, Vol. 7, pp. 16 - 23.
- NCHRP213: Lagasse, P.F., Richardson, E.V., Schall, J.D., Price, G.R., 1997. "Instrumentation for Measuring Scour at Bridge Piers and Abutments." NCHRP Project 213, Transportation Research Board, February.
- CLOPPER3: Clopper, P.E., 1992. "Protecting Embankment Dams with Concrete Block Systems." Hydro Review, Vol. X, No. 2, April.
- SIMONS: Simons, D.B., Chen Y.H., et al., 1984. "Hydraulic Tests to Develop Design Criteria for the Use of Reno Mattresses." Civil Engineering Department - Engineering Research Center, CSU, Fort Collins, Co, Report.
- FOTHERBY: Fotherby, L.M., Ruff, J.F., 1995. "Bridge Scour Protection System Using Toskanes - Phase 1." Pennsylvania Department of Transportation, Report 91-02.
- PAICE & HEY: Paice, C., Hey, R., 1993. "The Control and Monitoring of Local Scour at Bridge Piers." Hydraulic Engineering 93, San Francisco, CA, Proceedings (1993), pp. 1051-1055
- TRC 01: Berardi, D.A., Jones, S., Glenn, S.M., Higgins, T., Aboye, A.T., 1996. "An Experimental Study of Scour Protection Alternatives at Bridge Piers." FHWA-RD-95-187, Office of Engineering and Highway Operations, McLean VA.
- CHANG: Chang, L. and M. Karim, 1972. "An Experimental Study of Reducing Scour Around Bridge Piers Using Piles." South Dakota Department of Highways, Report.

(page intentionally left blank)

- **Areal river training structures** are countermeasures which cannot be described as transverse or longitudinal when acting as a system. This group also includes countermeasure “treatments” which have areal characteristics such as channelization, flow relief, and sediment detention.

Group 1.B Armoring Countermeasures. Armoring countermeasures are distinctive because they resist the erosive forces caused by a hydraulic condition. Armoring countermeasures do not necessarily alter the hydraulics of a reach, but act as a resistant layer to hydraulic shear stresses providing protection to the more erodible materials underneath. Armoring countermeasures generally do not vary by function, but vary more in material type. Armoring countermeasures are classified by two functional groups: **revetments and bed armoring** or **local armoring**.

- **Revetments and bed armoring** are used to protect the channel bank and/or bed from erosive/hydraulic forces. They are usually applied in a blanket type fashion for areal coverage. Revetments and bed armoring can be classified as either **rigid** or **flexible/articulating**. **Rigid** revetments and bed armoring are typically impermeable and do not have the ability to conform to changes in the supporting surface. These countermeasures often fail due to undermining. **Flexible/articulating** revetments and bed armoring can conform to changes in the supporting surface and adjust to settlement. These countermeasures often fail by removal and displacement of the armor material.
- **Local scour armoring** is used specifically to protect individual substructure elements of a bridge from local scour. Generally, the same material used for revetments and bed armoring is used for local armoring, but these countermeasures are designed and placed to resist local vortices created by obstructions to the flow.

2.3.2 Group 2. Structural Countermeasures

Structural countermeasures involve modification of the bridge structure (foundation) to prevent failure from scour. Typically, the substructure is modified to increase bridge stability after scour has occurred or when a bridge is assessed as scour critical. These modifications are classified as either **foundation strengthening** or **pier geometry modifications**.

- **Foundation strengthening** includes additions to the original structure which will reinforce and/or extend the foundations of the bridge. These countermeasures are designed to prevent failure when the channel bed is lowered to an expected scour elevation, or to restore structural integrity after scour has occurred. Design and construction of bridges with continuous spans provide redundancy against catastrophic failure due to substructure displacement as a result of scour. Retrofitting a simple span bridge with continuous spans could also serve as a countermeasure after scour has occurred or when a bridge is assessed as scour critical.
- **Pier geometry modifications** are used to either reduce local scour at bridge piers or to transfer scour to another location. These modifications are used primarily to minimize local scour.

2.3.3 Group 3. Monitoring

Monitoring describes activities used to facilitate early identification of potential scour problems. Monitoring could also serve as a continuous survey of the scour progress around the bridge foundations. Monitoring allows for action to be taken before the safety of the public is threatened by the potential failure of a bridge. Monitoring can be accomplished with instrumentation or visual inspection. A well designed monitoring program can be a very cost-effective countermeasure. Two types of instrumentation are used to monitor bridge scour: **fixed instruments** and **portable instruments** (see Chapter 7).

- **Fixed instrumentation** describes monitoring devices which are attached to the bridge structure to detect scour at a particular location. Typically, fixed monitors are located at piers and abutments. The number and location of piers to be instrumented should be defined, as it may be impractical to place a fixed instrument at every pier and abutment on a bridge. Instruments such as sonar monitors can be used to provide a timeline of scour, whereas instruments such as magnetic sliding collars can only be used to monitor the maximum scour depth. Data from fixed instruments can be downloaded manually at the site or it can be telemetered to another location.
- **Portable instrumentation** describes monitoring devices that can be manually carried and used along a bridge and transported from one bridge to another. Portable instruments are more cost effective in monitoring an entire bridge than fixed instruments; however, they do not offer a continuous watch over the structure. The allowable level of risk will affect the frequency of data collection using portable instruments.
- **Visual inspection** describes standard monitoring practices of inspecting the bridge on a regular interval and increasing monitoring efforts during high flow events (flood watch). Typically, bridges are inspected on a biennial schedule where channel bed elevations at each pier location are taken. The channel bed elevations should be compared with historical cross sections to identify changes due to scour. Channel elevations should also be taken during and after high flow events. If measurements cannot be safely collected during a high flow event, the bridge owner should determine if the bridge is at risk and if closure is necessary. Underwater inspections of the foundations could be used as part of the visual inspection after a flood.

2.4 BIOLOGICAL COUNTERMEASURES

A countermeasure group not included in the matrix is biological countermeasures such as biotechnical/bioengineering stabilization. This group was not listed because it is not as well accepted as the classical engineering approaches to bridge stability. Bioengineering is a relatively new field with respect to scour and stream instability at highway bridges. There is research being conducted in this field, but bioengineering techniques have generally not been tested specifically as a countermeasure to protect bridges in the riverine environment. For further discussion of bioengineered countermeasures, see Section 4.7.

2.5 COUNTERMEASURE CHARACTERISTICS

The countermeasure matrix (Table 2.1) was developed to identify distinctive characteristics for each type of countermeasure. Five categories of countermeasure characteristics were defined to aid in the selection and implementation of countermeasures:

- Functional Applications
- Suitable River Environment
- Maintenance
- Installation/Experience by State
- Design Guidelines Reference

These categories were used to answer the following questions:

- For what type of problem is the countermeasure applicable?
- In what type of river environment is the countermeasure best suited or, are there river environments where the countermeasure will not perform well?
- What level of resources will need to be allocated for maintenance of the countermeasure?
- What states or regions in the U.S. have experience with this countermeasure?
- Where do I obtain design guidance reference material?

2.5.1 Functional Applications

The functional applications category describes the type of scour or stream instability problem for which the countermeasure is prescribed. The five main categories of functional applications are local scour at abutments and piers, contraction scour, and vertical and lateral instability. Vertical instability implies the long-term processes of aggradation or degradation over relatively long river reaches, and lateral instability involves a long-term process of channel migration and bankline erosion problems. To associate the appropriate countermeasure type with a particular problem, filled circles, half circles and open circle are used in the matrix as described below:

- **well suited/primary use** - the countermeasure is well suited for the application; the countermeasure has a good record of success for the application; the countermeasure was implemented primarily for this application.
- ◐ **possible application/secondary use** - the countermeasure can be used for the application; the countermeasure has been used with limited success for the application; the countermeasure was implemented primarily for another application but also can be designed to function for this application.

In addition, this symbol can identify an application for which the countermeasure has performed successfully and was implemented primarily for that application, but there is only a limited amount of data on its performance and therefore the application cannot be rated as well suited.

- **unsuitable/rarely used** - the countermeasure is not well suited for the application; the countermeasure has a poor record of success for the application; the countermeasure was not intended for this application.

N/A not applicable - the countermeasure is not applicable to this functional application.

2.5.2 Suitable River Environment

This category describes the characteristics of the river environment for which a given countermeasure is best suited or under which there would be a reasonable expectation of success. Conversely, this category could indicate conditions under which experience has shown a countermeasure may not perform well. The river environment characteristics that can have a significant effect on countermeasure selection or performance are:

- River type
- Stream size (width)
- Bend radius
- Flow velocity
- Bed material
- Ice/debris load
- Bank condition
- Floodplain (width)

For each environmental characteristic, a qualitative range is established (e.g., stream size: **Wide**, **Moderate**, or **Small**) to serve as a suitability discriminator. While most characteristics are self explanatory, both HEC-20⁽²³⁾ ("Stream Stability at Highway Structures") and HDS 6⁽⁴⁾ ("River Engineering for Highway Encroachments") provide guidance on the range and definitions of these characteristics of the river environment. In the context of this matrix, the bank condition characteristic (**Vertical**, **Steep**, or **Flat**) considers the effectiveness of a given countermeasure to **protect** a bank with that configuration, **not** the suitability for installation of the countermeasure **on** a bank with that configuration.

- ✓ Where a block is **checked** for a given countermeasure under an environmental characteristic, the countermeasure is considered suitable or has been applied successfully for the full range of that environmental characteristic.

The checked block means that the characteristic **does not influence** the selection of the countermeasure, i.e., the countermeasure is suitable for the full range of that characteristic. For example, **guide banks** have been applied successfully in braided, meandering, and straight streams; however, **bendway weirs/stream barbs** are most suitable for installation on meandering streams.

2.5.3 Maintenance

The maintenance category identifies the estimated level of maintenance that may need to be allocated to service the countermeasure. The ratings in this category range from "**Low**" to "**High**" and are subjective. The ratings represent the relative amount of resources required for maintenance with respect to other countermeasures within the matrix shown in Table 2.1. A low rating indicates that the countermeasure is relatively maintenance free, a moderate rating indicates that some maintenance is required, and a high rating indicates that the countermeasure requires more maintenance than most of the countermeasures in the matrix.

2.5.4 Installation/Experience by State Departments of Transportation

This category identifies DOTs for which information on the use of a particular countermeasure was available. These listings may not include all of the states which have used a particular countermeasure. Information on state use was obtained from three sources: a National Cooperative Highway Program questionnaire (University of Minnesota survey for NCHRP Project 24-7); Brice and Blodgett, "Countermeasures for Hydraulic Problems at Bridges, Volumes 1 and 2," (1978)⁽¹²⁾; and correspondence with DOT staff. **It is expected that additional information on state use will be obtained as this matrix is distributed and revised.** Certain countermeasures are used by many states. These countermeasures have a listing of "Widely Used" in this category. Both successful, and unsuccessful experiences are reflected by the listing.

2.5.5 Design Guideline Reference

Reference manuals which provide guidance in countermeasure design have been developed by government agencies through research programs. The FHWA has produced a wealth of information through the federally coordinated program of highway research and development. The design guideline reference column identifies reference manuals where guidance on design of the countermeasures can be obtained. The references are symbolized by numbers in this column. The numbers correspond to the numbers of the references listed on the second page of the matrix (see also Chapter 8, References). Countermeasures for which design guidelines are provided within this document are referenced using **DG#**, where # represents a number assigned to the design guideline (see Chapter 5, Countermeasure Design Guidelines).

2.6 SUMMARY

The countermeasures matrix is convenient reference guide on a wide range of countermeasures applicable to scour and stream stability problems. A comprehensive plan of action would provide conceptual design and cost information on several alternative countermeasures, with a recommended alternative based on a variety of engineering, environmental and cost factors. The countermeasures matrix is a good way to begin identifying and prioritizing possible alternatives. The information provided in the matrix related to functional applications, suitable river applications and maintenance issues should facilitate preliminary selection of feasible alternatives prior to more detailed investigation.

(page intentionally left blank)

CHAPTER 3

CONSIDERATIONS FOR SELECTING COUNTERMEASURES

3.1 INTRODUCTION

As previously noted, a countermeasure is defined as a measure incorporated into a highway-stream crossing system to monitor, control, inhibit, change, delay, or minimize stream and bridge stability problems. A plan of action for monitoring structures during and/or after flood events and river stabilizing works over a reach of the river up and downstream of the crossing can also be considered countermeasures.

Countermeasures may be installed at the time of highway construction or retrofitted to resolve stability problems at existing crossings. Retrofitting is good economics and good engineering practice in many locations because the magnitude, location, and nature of potential stability problems are not always discernible at the design stage, and indeed, may take a period of several years to develop.

A countermeasure does not need to be a separate structure, but may be an integral part of the highway. For example, relief bridges on floodplains are countermeasures which alleviate scour from flow contraction at the bridge over the stream channel. Some features that are integral to the highway design serve as countermeasures to minimize stream stability problems. Abutments and piers oriented with the flow reduce local scour and contraction scour. Also, reducing the number of piers and/or setting back the abutments reduces contraction scour.

Countermeasures which are not integral to the highway may serve one function at one location and a different function at another. For examples, bank revetment may be installed to control bank erosion from meander migration, or it may be used to stabilize streambanks in the contracted area at a bridge. Other countermeasures are useful for one function only. This category of countermeasures includes spurs constructed in the stream channel to control meander migration.

In selecting a countermeasure it is necessary to evaluate how the stream might respond to the countermeasure, and also how the stream may respond as the result of the activities of other parties.

A countermeasure for scour critical bridges and unknown foundations could also be monitoring a bridge during and/or after a flood event. If monitoring is selected and if the risk of scour failure is high, protection to reduce the risk such as riprap or instrumentation should be provided. At this time the sizing of riprap to resist scour is not fail-safe (for additional guidance see HEC-18, Appendix I). Therefore, even if riprap is placed around piers or abutments, the high risk bridge should be monitored during and inspected after floods. If monitoring is selected, a plan of action should be implemented which includes a notification process, flood watch procedures, a highway closure process, documentation of available detours, inspection procedures, assessment procedures, and a repair notification process (see Sections 1.5, 2.1, and HEC-18⁽²⁴⁾).

The next section provides some general criteria for the selection of countermeasures for stream instability. Then, the selection of countermeasures for specific stream instability and bridge scour problems is discussed.

3.2 SELECTION OF COUNTERMEASURES FOR STREAM INSTABILITY

The selection of an appropriate countermeasure for a specific bank erosion problem is dependent on factors such as the erosion mechanism, stream characteristics, construction and maintenance requirements, potential for vandalism, and costs. Perhaps more important, however, is the effectiveness of the measure selected in performing the required function.

Protection of an existing bank line may be accomplished with revetments, spurs, retardance structures, longitudinal dikes, or bulkheads (see Chapter 2 and Table 2.1). Spurs, longitudinal dikes, and area retardance structures can be used to establish a new flow path and channel alignment, or to constrict flow in a channel. Because of their high cost, bulkheads may be appropriate for use only where space is at a premium. Channel relocation may be used separately or in conjunction with other countermeasures to change the flow path and flow orientation.

3.2.1 Erosion Mechanism

Bank erosion mechanisms are surface erosion and/or mass wasting. Surface erosion is the removal of soil particles by the velocity and turbulence of the flowing water. Mass wasting is by slides, rotational slip, piping and block failure. In general slides, rotational slip and block failure result from the bank being undercut by the flow. Also, seepage force of the pore water in the bank is another factor that can cause surface erosion or mass wasting. The type of mechanism is determined by the magnitude of the erosive forces of the water, type of bed and bank material, vegetation, and bed elevation stability of the stream. These mechanisms are described in HDS 6⁽⁴⁾ and HEC-20.⁽²³⁾

3.2.2 Stream Characteristics

Stream characteristics that influence the selection of countermeasures include (see also Table 2.1):

- Channel width
- Bank height
- Channel configuration
- Channel material
- Vegetative cover
- Sediment transport condition
- Bend radii
- Channel velocities and flow depth
- Ice and debris
- Floodplain characteristics

Channel Width. Channel width influences the use of bendway weirs and other spur-type countermeasures. On smaller streams (<75 m (250 feet) wide), flow constriction resulting from the use of spurs may cause erosion of the opposite bank. However, spurs can be used on small channels where the purpose is to shift the location of the channel.

Bank Height. Low banks (<3 m (10 feet)) may be protected by any of the countermeasures, including bulkheads. Medium height banks (from 3 to 6 m (10 to 20 feet)) may be protected by revetment, retardance structures, spurs, and longitudinal dikes. High banks (>6 m (20 feet)) generally require revetments used alone or in conjunction with other measures.

Channel Configuration. Spurs and jack fields have been successfully used as a countermeasure to control the location of the channel in meandering and braided streams. Also, bulkheads, revetments, and riprap have been used to control bank erosion resulting from stream migration. On anabranching streams, revetments, riprap, and spurs have been used to control bank erosion and channel shifting. Also, channels that do not carry large flows can and have been closed off. In one case, HDS 6 reports that a large channel was closed off and revetment and riprap used to control erosion in the other channel.⁽⁴⁾

Channel Material. Spurs, revetments, riprap, jack fields, or check dams can be used in any type of channel material if they are designed correctly. However, jack fields should only be placed on streams that carry appreciable debris and sediment in order for the jacks to cause deposition and eventually be buried.

Bank Vegetation. Vegetation such as willows can enhance the performance of structural countermeasures and may, in some cases, reduce the level of structural protection needed. Meander migration and other bank erosion mechanisms are accelerated on many streams in reaches where vegetation has been cleared.

Sediment Transport. The sediment transport conditions can be described as regime, threshold, or rigid. Regime channel beds are those which are in motion under most flow conditions, generally in sand or silt-size noncohesive materials. Threshold channel beds have no bed material transport at normal flows, but become mobile at higher flows. They may be cut through cohesive or noncohesive materials, and an armor layer of coarse-grained material can develop on the channel bed. Rigid channel beds are cut through rock or boulders and rarely or never become mobile. In general, permeable structures will cause deposition of bed material in transport and are better suited for use in regime and some threshold channels than in rigid channel conditions. Impermeable structures are more effective than permeable structures in channels with little or no bed load, but impermeable structures can also be very effective in mobile bed conditions. Revetments can be effectively used with mobile or immobile channel beds.

Bend Radii. Bend radii affect the design of countermeasures, because some countermeasures will only function properly in long or moderate radius bends. Thus, the cost per meter (foot) of bank protection provided by a specific countermeasure may differ considerably between short-radius and longer radius bends.

Channel Velocities and Flow Depth. Channel hydraulics affect countermeasure selection because structural stability and induced scour must be considered. Some of the permeable flow retardance measures may not be structurally stable and countermeasures which utilize piles may be susceptible to scour failure in high velocity environments.

Ice and Debris. Ice and debris can damage or destroy countermeasures and should always be considered during the selection process. On the other hand, the performance of some permeable spurs and area retardance structures is enhanced by debris where debris accumulation induces additional sediment deposition.

Floodplains. In selecting countermeasures for stream stability and scour, the amount of flow on the floodplain is an important factor. For example, if there is appreciable overbank flow, then the use of guide banks to protect abutments should be considered. Also, spurs perpendicular to the approach embankment may be required to control erosion.

3.2.3 Construction and Maintenance Requirements

Standard requirements regarding construction or maintenance such as the availability of materials, construction equipment requirements, site accessibility, time of construction, contractor familiarity with construction methods, and a program of regular maintenance, inspection, and repair are applicable to the selection of appropriate countermeasures. Additional considerations for countermeasures located in stream channels include: constructing and maintaining a structure that may be partially submerged at all times, the extent of bank disturbance which may be necessary, and the desirability of preserving streambank vegetative cover to the extent practicable.

3.2.4 Vandalism

Vandalism is always a maintenance concern since effective countermeasures can be made ineffective by vandals. Documented vandalism includes dismantling of devices, burning, and cutting or chopping with knives, wire cutters, and axes. Countermeasure selection or material selection for construction may be affected by concerns of vandalism. For example, rock-filled baskets (gabions) may not be appropriate in some urban environments.

3.2.5 Costs

Cost comparisons should be used to study alternative countermeasures with an understanding that the measures were installed under widely varying stream conditions, that the conservatism (or lack thereof) of the designer is not accounted for, that the relative effectiveness of the measures cannot be quantitatively evaluated, and that some measures included in the cost data may not have been fully tested by floods.

Figure 3.1 provides some insight regarding the relative costs of major countermeasure types. Although the study was done in 1985 and costs have increased, the relative cost probably has not changed. The bars represent the cost range for each countermeasure included in the comparison and the darkened portion of each bar represents the dominant range of costs. Numbers following the countermeasure type are the number of sites included in the cost analysis. The figure shows that rock spurs, horizontal wood slat spurs, rock windrow revetments, vegetation, jack retardance structures, wood-fence retardance structures, and rock toe dikes are usually the least expensive. Henson-type (vertical wood slat) spurs, cellular block revetments, and concrete-filled mats are generally the most expensive. Rock riprap revetment costs per meter of bank protection vary widely, but the dominant range of costs are not out of line with costs for other countermeasures.

3.3 COUNTERMEASURES FOR MEANDER MIGRATION

The best countermeasure against meander migration is to locate the bridge crossing on a relatively straight reach of stream between bends. At many such locations, countermeasures may not be required for several years because of the time required for the bend to move to a location where it becomes a threat to the highway facility. However, bend migration rates on other streams may be such that countermeasures will be required after a few years or a few flood events and, therefore, should be installed during initial construction. See HEC-20⁽²³⁾ for further discussion of lateral channel instability.

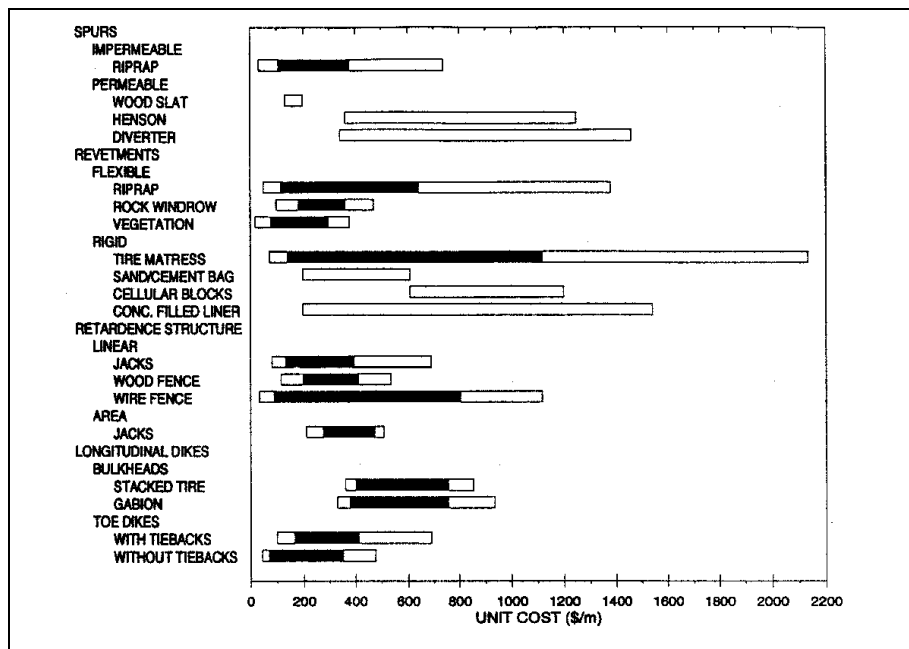

Figure 3.1. Countermeasure costs per meter of bank protected (after Brown).⁽²⁾

Stabilizing channel banks at a highway stream crossing can cause a change in the channel cross section and an increase in stream sinuosity upstream of the stabilized banks. Figure 3.2a illustrates a natural channel section in a bend with the deeper section at the outside of the bend and a gentle slope toward the inside bank resulting from point bar growth. Figure 3.2b illustrates the scour which results from stabilizing the outside bank of the channel and the resulting steeper slope of the point bar on the inside of the bend. This effect must be considered in the design of the countermeasure and the bridge (see Section 4.3.5). It should also be recognized that the thalweg location and flow direction can change as sinuosity upstream increases.

Figure 3.3a illustrates meander migration in a natural stream and Figure 3.3b, the effects of bend stabilization on upstream sinuosity. As sinuosity increases, meander amplitude may increase, meander radii will become smaller, deposition may occur because of reduced slopes, and the channel width-depth ratio may increase as a result of bank erosion and deposition, as at the bridge location shown in Figure 3.3b. Ultimately, cutoffs can occur. These changes can also result in hydraulic problems downstream of the stabilized bend.

Countermeasures for meander migration include those that:

- Protect an existing bank line
- Establish a new flow line or alignment
- Control and constrict channel flow

The classes of countermeasures identified for bank stabilization and bend control are bank revetments, spurs, retardance structures, longitudinal dikes, vane dikes, bulkheads, and channel relocations. Also, a carefully planned cutoff may be an effective way to counter problems created by meander migration. These measures may be used individually or in combination to combat meander migration at a site. Some of these countermeasures are also applicable to bank erosion from causes other than bend migration.

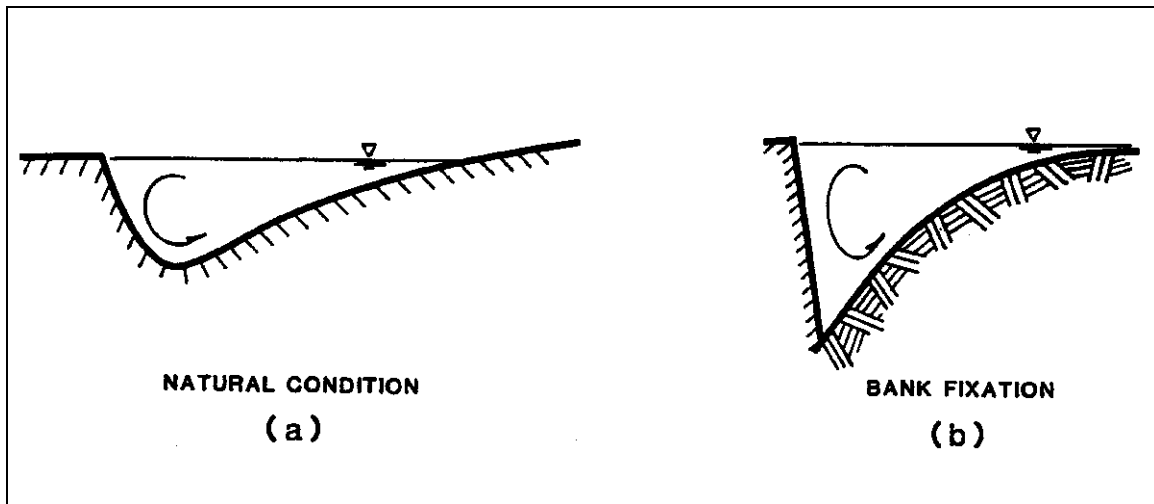

Figure 3.2. Comparison of channel bend cross sections (a) for natural conditions, and (b) for stabilized bend (after Brown).⁽²⁾

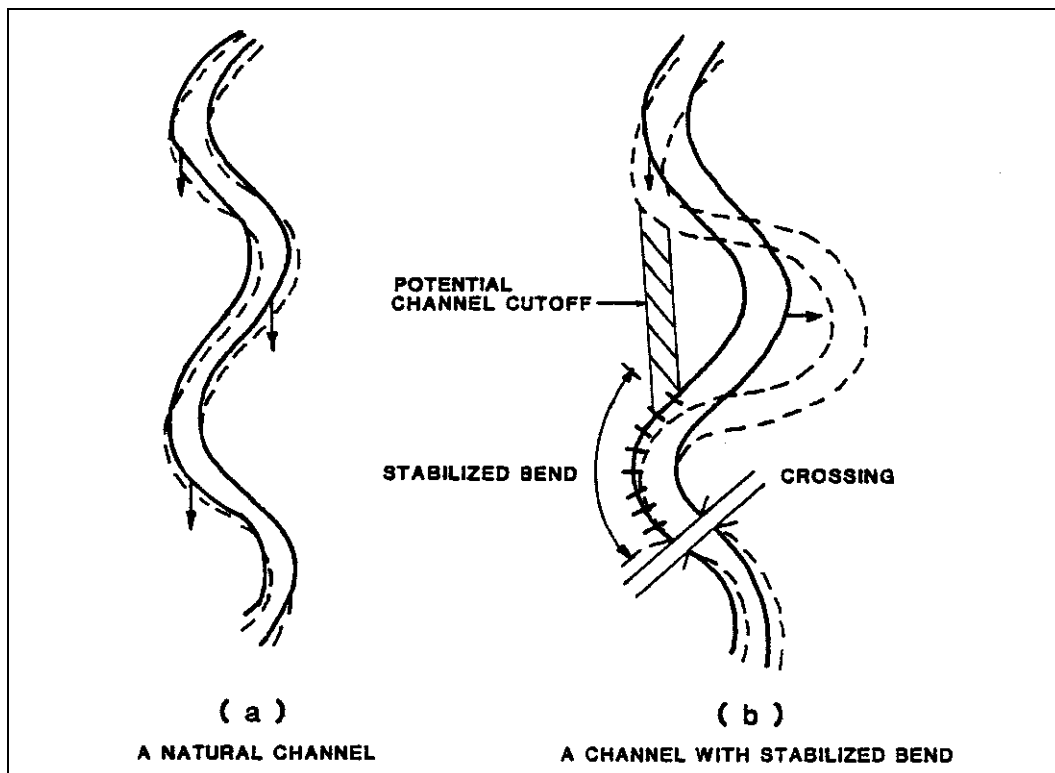

Figure 3.3. Meander migration in (a) a natural channel, and (b) a channel with stabilized bend (after Brown).⁽²⁾

3.4 COUNTERMEASURES FOR CHANNEL BRAIDING AND ANABRANCHING

Channel braiding occurs in streams with an overload of sediment, causing deposition and aggradation. As aggradation occurs, the slope of the channel increases, velocities increase, and multiple, interconnected channels develop. The overall channel system becomes wider and multiple channels are formed as bars of sediment are deposited in the main channel.

Braiding can also occur where banks are easily eroded and there is a large range in discharge. The channel becomes wider at high flows, and low-flow forms multiple interconnected channels. In an anabranching stream, flow is divided by islands rather than bars, and the anabranching channels are more permanent than braided channels and generally convey more flow.

A meandering stream may change to a braided stream if the slope is increased by channel straightening or the dominant discharge is increased. Lane's relation may be used to determine if there can be a shift from a meandering channel to a braided one. If, after a change in discharge or slope the stream still plots in the meandering zone, then it will remain a meandering stream. However, if it moves closer to or into the braided zone, then the stream may become braided (see HEC-20,⁽²³⁾ Chapter 4).

Braided channels change alignment rapidly, and are very wide and shallow even at flood flow. They present problems at bridge sites because of the high cost of bridging the complete channel system, unpredictable channel locations and flow directions, difficulties with eroding channel banks, and in maintaining bridge openings unobstructed by bars and islands.

Countermeasures used on braided and anabranching streams are usually intended to confine the multiple channels to one channel. This tends to increase the sediment transport capacity in the principal channel and encourage deposition in secondary channels. These measures usually consist of dikes constructed from the margins of the braided zone to the channel over which the bridge is constructed. Guide banks at bridge abutments (Design Guideline 10) in combination with revetment on highway fill slopes (Design Guideline 12), riprap on highway fill slopes only, and spurs (Design Guideline 9) arranged in the stream channels to constrict flow to one channel have also been used successfully.

Since anabranches are permanent channels that may convey substantial flow, diversion and confinement of an anabranching stream is likely to be more difficult than for a braided stream. The designer may be faced with a choice of either building more than one bridge, building a long bridge, or diverting anabranches into a single channel.

3.5 COUNTERMEASURES FOR DEGRADATION AND AGGRADATION

Bed elevation instability problems are common on alluvial streams. Degradation in streams can cause the loss of bridge piers in stream channels and can contribute to the loss of piers and abutments located on caving banks. Aggradation causes the loss of waterway opening in bridges and, where channels become wider because of aggrading streambeds, overbank piers and abutments can be undermined. At its worst, aggradation may cause streams to abandon their original channels and establish new flow paths which could isolate the existing bridge. See HEC-20⁽²³⁾ for further discussion of vertical channel instability.

3.5.1 Countermeasures to Control Degradation

Countermeasures used to control bed degradation include check dams and channel linings. Check-dams and structures which perform functions similar to check-dams include drop structures, cutoff walls, and drop flumes. A check-dam is a low dam or weir constructed across a channel to prevent upstream degradation (Design Guideline 11).

Channel linings of concrete and riprap have proved unsuccessful at stopping degradation. To protect the lining, a check-dam may have to be placed at the downstream end to key it to the channel bed. Such a scheme would provide no more protection than would a check dam alone, in which case the channel lining would be redundant.

Bank erosion is a common hydraulic hazard in degrading streams. As the channel bed degrades, bank slopes become steeper and bank caving failures occur. The USACE found that longitudinal stone dikes, or rock toe-dikes (Chapter 6), provided the most effective toe protection of all bank stabilization measures studied for very dynamic and/or actively degrading channels.

The following is a condensed list of recommendations and guidelines for the application of countermeasures at bridge crossings experiencing degradation:

- Check-dams or drop structures are the most successful technique for halting degradation on small to medium streams.
- Channel lining alone may not be a successful countermeasure against degradation problems.
- Combinations of bulkheads and riprap revetment have been successfully used to protect abutments where steep streambanks threaten abutment fill slopes.
- Riprap on channel banks and spill slopes will fail if unanticipated channel degradation occurs.
- Successful pier protection involves providing deeper foundations at piers and pile bents.
- Jacketing piers with steel casings or sheet piles has also been successful where expected degradation extends only to the top of the original foundation.
- The most economical solution to degradation problems at new crossing sites on small to medium size streams is to provide adequate foundation depths. Adequate setback of abutments from slumping banks is also necessary.
- Rock-and-wire mattresses are recommended for use only on small (<30 m [100 ft]) channels experiencing lateral instability and little or no vertical instability.
- Longitudinal stone dikes placed at the toe of channel banks are effective countermeasures for bank caving in degrading streams. Precautions to prevent outflanking, such as tiebacks to the banks, may be necessary where installations are limited to the vicinity of the highway stream crossing.

3.5.2 Countermeasures to Control Aggradation

Currently, measures used in attempts to alleviate aggradation problems at highways include channelization, debris basins, bridge modification, and/or continued maintenance, or combinations of these. Channelization may include dredging and clearing channels, constructing small dams to form debris basins, constructing cutoffs to increase the local slope, constructing flow control structures to reduce and control the local channel width, and constructing relief channels to improve flow capacity at the crossing. Except for debris basins and relief channels, these measures are intended to increase the sediment transport capacity of the channel, thus reducing or eliminating problems with aggradation. Cutoffs must be designed with considerable study as they can cause erosion and degradation upstream and deposition downstream. These studies would involve the use of sediment transport relations given in HDS 6⁽⁴⁾ or the use of sediment transport models such as BRI-STARS⁽²⁵⁾ or HEC-6.⁽²⁶⁾ The most common bridge modifications are increasing the bridge length by adding spans and increasing the effective flow area beneath the structure by raising the bridge deck.

A program of continuing maintenance has been successfully used to control problems at bridges on aggrading streams. In such a program, a monitoring system is set up to survey the affected crossing at regular intervals. When some pre-established deposition depth is reached, the bridge opening is dredged or cleared of the deposited material. In some cases, this requires opening a clearing after every major flood. This solution requires surveillance and dedication to the continued maintenance of an adequate waterway under the bridge. Otherwise, it is only a temporary solution. A debris basin or a deeper channel upstream of the bridge may be easier to maintain. Continuing maintenance is not recommended if analysis shows that other countermeasures are practicable.

Over the short term, maintenance programs prove to be very cost effective when compared with the high cost of channelization, bridge alterations, or relocations. When costs over the entire life of the structure are considered, however, maintenance programs may cost more than some of the initially more expensive measures. Also, the reliability of maintenance programs is generally low because the programs are often abandoned for budgetary or priority reasons. However, a program of regular maintenance could prove to be the most cost efficient solution if analysis of the transport characteristics and sediment supply in a stream system reveals that the aggradation problem is only temporary (perhaps the excess sediment supply is coming from a construction site) or will have only minor effects over a relatively long period of time.

An alternative similar to a maintenance program which could be used on streams with persistent aggradation problems, such as those on alluvial fans, is the use of controlled sand and gravel mining from a debris basin constructed upstream of the bridge site. Use of this alternative would require careful analysis to ensure that the gravel mining did not upset the balance of sediment and water discharges downstream of the debris basin. Excessive mining could induce degradation downstream, potentially impacting the bridge or other structures.

Following is a list of guidelines regarding aggradation countermeasures:

- Extensive channelization projects have generally proven unsuccessful in alleviating general aggradation problems, although some successful cases have been documented. A sufficient increase in the sediment carrying capacity of the channel is usually not achieved to significantly reduce or eliminate the problem. Channelization should be considered only if analysis shows that the desired results will be achieved.
- Alteration or replacement of a bridge is often required to accommodate maximum aggradation depths.
- Maintenance programs have been unreliable, but they provide the most cost-effective solution where aggradation is from a temporary source or on small channels where the problem is limited in magnitude.
- At aggrading sites on wide, shallow streams, spurs or dikes with flexible revetment have been successful in several cases in confining the flow to narrower, deeper sections.
- A debris basin and controlled sand and gravel mining might be the best solution on alluvial fans (see HEC-20⁽²³⁾) and at other crossings with severe problems.

3.6 SELECTION OF COUNTERMEASURES FOR SCOUR AT BRIDGES

The selection of an appropriate countermeasure for scour at a bridge requires an understanding of the erosion mechanism producing the specific scour problem. For example, contraction scour results from a sediment imbalance across most or all of the channel while local scour at a pier or abutment results from the action of vortices at an obstruction to the flow. Degradation is a component of total scour, but is considered a channel instability problem (see Section 3.5). Since the selection of a countermeasure depends on the type of scour involved this section provides a brief overview of the principal scour components.

Scour is the result of the erosive action of running water, excavating and carrying away material from the bed and banks of streams. Different materials scour at different rates. Loose granular soils are rapidly eroded under water action while cohesive or cemented soils are more scour-resistant. However, ultimate scour in cohesive or cemented soils can be as deep as scour in sand-bed streams. Scour will reach its maximum depth in sand and gravel bed materials in hours; cohesive bed materials in days; glacial tills, poorly cemented sand stones and shales in months; hard, dense and cemented sandstone or shales in years; and granites in centuries. Massive rock formations with few discontinuities can be highly resistant to scour and erosion during the lifetime of a typical bridge. See HEC-18⁽²⁴⁾ for detailed discussion and equations for calculating all bridge scour components.

Designers and inspectors need to carefully study site-specific subsurface information in determining scour potential at bridges, giving particular attention to foundations on rock.

Total Scour. Total scour at a highway crossing is comprised of three components. These components are:

- Aggradation and Degradation. These are long-term streambed elevation changes due to natural or human-induced causes within the reach of the river on which the bridge is located (see Section 3.5).
- Contraction Scour. This type of scour involves the removal of material from the bed and banks across all or most of the width of a channel. This scour can result from a contraction of the flow by the approach embankments to the bridge encroaching onto the floodplain and/or into the main channel, a change in downstream control of the water surface elevation, or the location of the bridge in relation to a bend. In each case, the scour is caused by an increase in transport of the bed material in the bridge cross section.
- Local Scour. This scour occurs around piers, abutments, spurs, and embankments and is caused by the acceleration of the flow and the development of vortex systems induced by these obstructions to the flow.

In addition to the types of scour mentioned above, lateral migration of the stream may also erode the approach roadway to the bridge or change the total scour by changing the angle of the flow in the waterway at the bridge crossing. Factors that affect lateral migration and the stability of a bridge are the geomorphology of the stream, location of the crossing on the stream, flood characteristics, and the characteristics of the bed and bank materials (see HEC-20).⁽²³⁾

3.6.1 Countermeasures for Contraction Scour

Severe contraction of flow at highway stream crossings has resulted in numerous bridge failures at abutments, approach fills, and piers from contraction scour. Design alternatives to decrease contraction scour include longer bridges, relief bridges on the floodplain, superstructures at elevations above flood stages of extreme events, and a crest vertical profile on approach roadways to provide for overtopping during floods exceeding the design flood event (see HEC-20).⁽²³⁾ These design alternatives are integral features of the highway facility which reduce the contraction at bridges and, therefore, reduce the magnitude of contraction scour.

The elevation of bridge superstructures is recognized as important to the integrity of the bridge because of hydraulic forces that may damage the superstructure. These include buoyancy and impact forces from ice and other floating debris (see HEC-18).⁽²⁴⁾ Contraction scour is another consideration in setting the superstructure elevation. When the superstructure of a bridge becomes submerged or when ice or debris lodged on the superstructure causes the flow to contract, flow may be accelerated and more severe scour can occur. For this reason, where contraction scour is of concern, bridge superstructures should be located with clearance for debris, and, if practicable, above the stage of floods larger than the design flood.

Another design feature which should be considered relative to contraction scour is the effective depth of the superstructure. Present day superstructures often include bridge railings which are solid parapets. These increase the effective depth of the superstructure and the importance of locating the bridge superstructure above high water with clearance for debris passage. It also increases the importance of alternate provisions for the passage of flood waters in the event of debris blockage of the waterway or superstructure submergence. Possible alternate provisions include relief bridges on the floodplain and a highway profile which provides for overtopping before the bridge superstructure begins to become submerged.

Similarly, pier design, span length, and pier location become more important contributors to contraction scour where debris can lodge on the piers and further contract flow in the waterway. In streams which carry heavy loads of debris, longer, higher spans and solid piers will help to reduce the collection of debris. Where practicable, piers should be located out of the main current in the stream, i.e., outside the thalweg at high flow. There are numerous locations where piers occupy a significant area in the stream channel and contribute to contraction scour, especially where devices to protect piers from ship traffic are provided.

The stream channel cross section under a bridge is sometimes designed to increase the waterway area and thereby decrease backwater upstream of the bridge and contraction scour in the waterway. In streams which carry large sediment loads, deposition may occur in the enlarged section of channel during smaller floods and on the recession of larger floods, thus rendering the channel excavation ineffective. However, for streams which do not carry a significant sediment load and on floodplains, excavation within the bridge waterway area will compensate for some of the lateral contraction of flow and reduce contraction scour.

Countermeasures used to reduce flow contraction include measures which retard flow along highway embankments on floodplains. Flow along highway fills usually intersects with flow within bridge openings at large angles. This causes additional contraction of the flow, vortices, and turbulence which produce local scour. The contraction of flow can be reduced by using spurs on the upstream side of the highway embankment to retard flow parallel with the highway.⁽⁵⁾

Guide banks (also referred to as spur dikes) at bridge abutments serve a similar purpose in addition to the purpose of aligning flow in the bridge opening. They reduce contraction scour because they increase the efficiency of the bridge opening and hence reduce flow contraction. The primary purpose of these guide banks, however, is to reduce local scour at abutments (Design Guideline 10).

The principal countermeasure used for reducing the effects of contraction is revetment on channel banks and fill slopes at bridge abutments (Design Guideline 12). However, guide banks may be used to reduce the effects of contraction by moving the site of local scour caused by the turbulence of intersecting flows and contraction away from the bridge abutment.

The potential for undesired effects from stabilizing all or any portion of the channel perimeter at a contraction should be considered. Stabilization of the banks may only result in exaggerated scour in the streambed near the banks or, in a relatively narrow channel, across the entire channel. Stabilization of the streambed may also result in exaggerated lateral scour in any size stream. Stabilization of the entire stream perimeter may result in downstream scour or failure of some portion of the countermeasures used on either the streambed or banks.

3.6.2 Countermeasures for Local Scour

Local scour occurs in bridge openings at piers and abutments. In general, design alternatives against structural failure from local scour consist of measures which reduce scour depth, such as pier shape and orientation, and measures which retain their structural integrity after scour reaches its maximum depth, such as placing foundations in sound rock and using deep piling. Countermeasures which can reduce the risk from scour include riprap.

Abutments. Countermeasures for local scour at abutments consist of measures which improve flow orientation at the bridge end and move local scour away from the abutment, as well as revetments and riprap placed on spill slopes to resist erosion.

Guide banks are earth or rock embankments placed at abutments. Flow disturbances, such as eddies and cross-flow, will be eliminated where a properly designed and constructed guide bank is placed at a bridge abutment. Guide banks also protect the highway embankment, reduce local scour at the abutment and adjacent piers, and move local scour to the end of the guide bank (Design Guideline 10).

Local scour also occurs at abutments as a result of expanding flow downstream of the bridge, especially for bridges on wide, wooded floodplains that have been cleared for construction of the highway. Short guide banks extending downstream of the abutment to the tree line will move this scour away from the abutment, and the trees will retard velocities so that flow redistribution can occur with minimal scour.

The effectiveness of guide banks is a function of stream geometry, the quantity of flow on the floodplain, and the size of bridge opening. A typical guide bank at a bridge opening is shown in Figure 3.4.

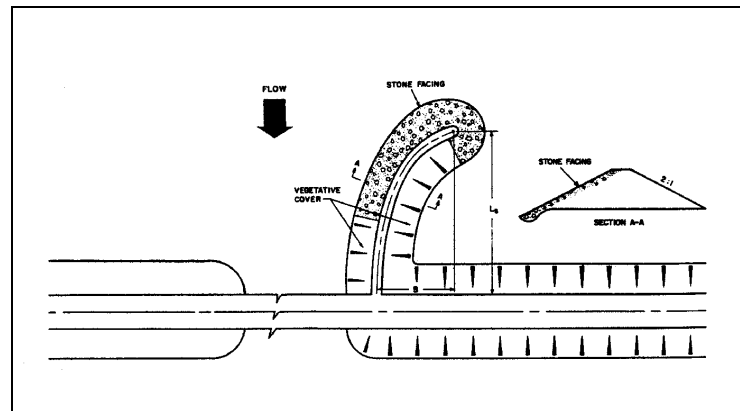

Figure 3.4. Typical guide bank layout and section (after Bradley).⁽⁵⁾

Revetments may consist of pervious rock or rigid concrete. Rock riprap revetment provides an effective countermeasure against erosion on spill slopes.⁽³⁾ Rigid revetments have been more successful where abutments are on the floodplain rather than in stream channels because hydrostatic pressure behind the revetments is not usually a problem. Precautions against undermining of the toe and upstream terminus of all revetments are always required (Design Guideline 12).

Other countermeasures have been successfully used to inhibit scour at abutments where the abutment is located at the streambank or within the stream channel. These measures include dikes to constrict the width of braided streams and retards to reduce velocities near the streambank.

Piers. Three basic methods may be used to prevent damage from local scour at piers. The first method is to place the foundation of the structure at such a depth that the structural stability will not be at risk with maximum scour. This must be done on all new or replacement bridges.⁽²⁴⁾ The second (for existing bridges) is to provide protection at or below the streambed to inhibit the development of a scour hole. The third measure is to prevent erosive vortices from forming or to reduce their strength and intensity.

Streamlining the pier nose decreases flow separation at the face of the pier, reducing the strength of the horseshoe vortices which form at piers. Practical application of this principle involves the use of rounded or circular shapes at the upstream and downstream faces of piers in order to reduce the flow separation. However, flow direction can and does change with time and with stage on some streams. Piers oriented with flow direction at one stage or at one point in time may be skewed with flow direction at another. Also, flow direction changes with the passage of bed forms. In general, piers should be aligned with the main channel design flow direction and skew angles greater than 5 degrees should be avoided. Where this is not possible, a single cylindrical pier or a row of cylindrical columns will produce a lesser depth of local scour.

The tendency of a row of columns to collect debris should be considered. Debris can greatly increase scour depths. Webwalls have been used between columns to add to structural strength and to reduce the tendency to collect debris. Webwalls should be constructed at the elevation of stream flood stages which carry floating debris and extended to the elevation of the streambed. When installing a webwall as a countermeasure against debris, the potential for significantly increased scour depths should be considered if the approach flow might impinge on the wall at a high angle of attack.

Riprap is commonly used to inhibit local scour at piers at existing bridges. This practice is not recommended as an adequate substitute for foundations or piling located below expected scour depths for new or replacement bridges. It is recommended as a retrofit or a measure to reduce the risk where scour threatens the integrity of a pier (Design Guideline 8). The practice of heaping stones around a pier is not recommended because experience has shown that continual replacement is usually required. Success rates have been better with alluvial bed materials where the top of the riprap was placed at or below the elevation of the streambed.

Piles (sheet, H beams or concrete) have been successfully used as a retrofit measure to lower the effective foundation elevation of structures where footings or pile caps have been exposed by scour. The piling is placed around the pile footings and anchored to the pile cap or seal to retain or restore the bearing capacity of the foundation. The increased mass of the retrofit pile will, however, produce greater depth of scour.

Where sheet pile cofferdams are used during construction, the sheet piling should be removed or cut off below the level of expected contraction scour in order to avoid contributing to local scour. Cofferdams should not be much wider than the pier itself since the effect may be to greatly increase local scour depth. Leaving or removing cofferdams must be carefully evaluated because leaving a cofferdam that is higher than the contraction scour elevation may increase local scour depth. Recent work by Jones gives a method to evaluate the expected scour depths for cofferdams.⁽²⁷⁾

3.6.3 Monitoring

Monitoring or closing a bridge during high flows and inspection after the flood may be an effective countermeasure to reduce the risk from scour. However, monitoring of bridges during high flow may not reveal that they are about to collapse from scour. It also may not be practical to close the bridge during high flow because of traffic volume, no (or poor) alternate routes, the need for emergency vehicles to use the bridge, etc. Under these circumstances, scour countermeasures such as riprap could be installed. A countermeasure installed at a bridge to reduce the risk from scour along with monitoring during and inspection after high flows could provide for the security of the public without closing the bridge.

CHAPTER 4

COUNTERMEASURE DESIGN CONCEPTS

4.1 COUNTERMEASURE DESIGN APPROACH

4.1.1 Investment in Countermeasures

At stream crossings, the objective of highway agencies is to protect highway users and the investment in the highway facility, and to avoid causing damage to other properties, to the extent practicable. Countermeasures should be designed and installed to stabilize only a limited reach of stream and to ensure the structural integrity of highway components in an unstable stream environment. Countermeasures are often damaged or destroyed by the stream, and streambanks and beds often erode at locations where no countermeasure was installed. However, as long as the primary objectives are achieved in the short-term as a result of countermeasure installation, the countermeasure installation can be deemed a success. Therefore, the highway agency's interest in stream stability often entails long-term protection of costly structures by committing to maintenance, reconstruction, and installation of additional countermeasures as the responses of streams and rivers to natural and man-induced changes are identified.

While it is sometimes possible to predict that bank erosion will occur at or near a given location in an alluvial stream, one can frequently be in error about the exact location or magnitude of potential erosion. At some locations, unexpected lateral erosion occurs because of a large flood, a shifting thalweg, or from other actions of the stream or human activities. Where the investment in a highway crossing is not in imminent danger of being lost, it is often prudent to delay the installation of countermeasures until the magnitude and location of the problem becomes obvious.

Thus, for stream instability countermeasures, a "wait and see" attitude may constitute the most economical approach. Retrofitting can be considered sound engineering practice in many locations because the magnitude, location, and nature of potential instability problems are not always discernible at the design stage, and indeed, may take a period of several years to develop.

4.1.2 Design Approach

The design of any countermeasure for the protection of highway crossings requires the designer to be cognizant of the factors which affect stream stability and the morphology of the stream. In most cases, the installation of any countermeasure will cause the bed and banks to respond to the change in hydraulic conditions imposed by the countermeasure. Thus, the analyses procedures outlined in HEC-20⁽²³⁾ are a necessary prerequisite to the detailed design of specific countermeasures. The goal in any countermeasure design is to achieve a response which is beneficial to the protection of the highway crossing and to minimize adverse effects either upstream or downstream of the highway crossing.

The bridge scour and stream instability countermeasures matrix (Table 2.1) helps define the set of specific countermeasures that are best suited to specific site conditions. The countermeasures matrix is intended, primarily, to assist with the selection of an appropriate countermeasure. Consideration of potential environmental impacts, maintenance, construction-related activities, and legal aspects can be used to refine the selection. The final selection criteria, and perhaps the most important, are the initial and long-term costs.

The countermeasure that provides the desired level of protection at the lowest total cost may be the “best” for a particular application.

The following principles should be followed in designing and constructing stream instability and bridge scour countermeasures:

- The initial and long-term cost should not exceed the benefits to be derived. Countermeasures to make the bridge safe from scour and stream instability should be used for important bridges on main roads and where the results of failure would be intolerable. Expendable works may be used where traffic volumes are light, alternative routes are available, and the risk of failure is acceptable.
- Designs should be based on studies of channel trends and processes and on experience with comparable situations. The environmental effects of the countermeasures on the channel both up- and downstream should be considered.
- Field reconnaissance by the designer is highly desirable and should include the watershed and river system up- and downstream from the bridge.
- Evaluation of time-sequenced aerial photography is a useful tool to detect long-term trends in river stability.
- Soil and geotechnical characteristics of the site and their influence on countermeasure design must be considered.
- The possibility of using physical model studies as a design aid should receive consideration at an early stage.
- Countermeasures must be inspected periodically after floods to check performance and modify the design, if necessary. The first design may require modification. Continuity in treatment, as opposed to sporadic attention, is advisable. The condition of the countermeasure should be documented with photographs to enable comparison of its condition from one inspection to another.
- In most cases, the countermeasure does not "cure" the instability or scour problem, and planning (funding) for continued maintenance of the countermeasure will be required.

In some cases, a combination of two or more countermeasures could be required due to site-specific problems or as a result of changing conditions after the initial installation. The great number of possible countermeasure combinations makes it impractical to suggest design procedures for combined countermeasures. However, combined countermeasures should complement each other. That is to say, the design of one countermeasure must not adversely impact on another or the overall protection of the highway crossing. The principles of river mechanics, as discussed in HDS 6⁽⁴⁾ and HEC-20,⁽²³⁾ coupled with sound engineering judgment should be used to design countermeasure strategies involving two or more countermeasures.

4.2 ENVIRONMENTAL PERMITTING

The environmental permitting process can have a significant effect on the planning, design and implementation of river engineering works. Often, permitting can become a lengthy

process for the implementation of bridge scour and stream instability countermeasures. To expedite this process, a memorandum dated February 11, 1997,⁽²⁸⁾ was prepared jointly by the U.S. Army Corps of Engineers (USACE) Directorate of Civil Works and the Federal Highway Administration (FHWA). The purpose of the memorandum is to facilitate timely decisions on permit applications for work associated with measures to protect bridges determined to be at risk as the result of scouring around their foundations. The USACE and FHWA consider this agreement essential to assure the safety of the traveling public while protecting the environment. Since installing protective armoring is usually determined to be the most feasible and economical method to protect bridge foundations, it is expected that USACE Districts may experience a significant increase in requests from bridge owners for permits for the installation of this type of scour countermeasure.

Recognizing the importance of protecting the foundations of our Nation's scour critical bridges with properly designed scour countermeasures and the need for environmentally sound projects, the FHWA and the USACE agree to work together with the bridge owners, in a cooperative effort, to plan ahead for managing projects that will need a USACE permit. A strong cooperative effort will aid in advanced planning to avoid and minimize environmental impacts, and in identifying locations where mitigation may be appropriate. If the bridge foundation has been determined to be scour critical as part of the bridge owner's scour evaluation program, the USACE will give priority to the bridge owner's request for authorization for the installation of scour countermeasures. Bridge owners must provide the FHWA and USACE Districts advance notice of the proposed countermeasure design and construction schedule. The notice must include an evaluation of the environmental impacts of the proposed scour countermeasure and appropriate mitigation of unavoidable impacts to aquatic resources, including fisheries and wetlands. This will allow appropriate and timely cooperation on project reviews. The USACE will make the maximum use possible of forms of expedited authorization, such as nationwide permits and regional permits, and Letters of Permission and the use of FHWA's Categorical Exclusion when the condition of the bridge foundation meets the criteria for codes 0 through 4 for Item 113.⁽²⁹⁾

4.3 HYDRAULIC ANALYSIS

4.3.1 Overview

To be successful, the design of any countermeasure must incorporate some level of hydraulic analysis. The hydraulic principles of open channel flow and fundamentals of alluvial channel flow are summarized in HDS 6⁽⁴⁾ and hydraulic factors that influence stream stability are presented in HEC-20.⁽²³⁾ In addition, HEC-20 provides a general solution approach which includes hydrologic and hydraulic analysis steps in a multi-level analysis procedure (see also Figure 1.1). Finally, HEC-18⁽²⁴⁾ provides references and discussion of the standard one- and two-dimensional hydraulic computer models used for riverine and tidal analyses.

Both physical hydraulic modeling in a laboratory and numerical computer modeling are among the standard techniques available to analyze the scour problem and design countermeasures. This section introduces the use of physical modeling for the design of scour and stream instability countermeasures. Guidance is also provided for the analysis of several complex hydraulic conditions applicable to countermeasure design: scour at transverse structures (spurs, jetties, dikes, and guidebanks) and longitudinal structures (bendway revetment and vertical walls).

4.3.2 Physical Models

The use of hydraulic models as a tool in hydraulic design is commonly accepted. Many hydraulic phenomena which occur in nature are too complex to be described by rigorous mathematical techniques and models are used as an alternative means of obtaining the information necessary to complete an efficient and satisfactory design. Even in relatively simple situations, such as the design of spillways or water diversion structures, it is often impossible to predict the exact nature of the flow patterns without conducting a model study.⁽³⁰⁾

A summary of the principles of physical modeling for both rigid-boundary and movable-bed river models can be found in Shen⁽³¹⁾ who notes that hydraulic modeling has contributed significantly to design of hydraulic structures, training of rivers, and basic hydraulic research. It is a common practice to conduct hydraulic model tests to verify or modify the design of prototype structures. Hydraulic model tests are particularly useful in the study of complex flow phenomena for which no completely satisfactory theoretical analysis is available.

Some hydraulic tests are rather routine; many others are complex. For simple situations, hydraulic model tests provide accurate information that can be applied directly to prototype situations. However, for complex situations, hydraulic modeling is still more of an art than a science.⁽³¹⁾ The following comments summarize important considerations for applying a physical model to the design of hydraulic structures, including countermeasures for bridge scour and stream instability.

- A physical model is very useful in the study of characteristics of complex flow phenomena involving significant flow variations in all three dimensions where no theoretical analysis is available.
- Dimensional analysis, physical reasoning, and inspection analysis are essential approaches to the selection of the governing similarity criteria. If more than one similarity criterion are needed, extensive knowledge of the basic process under investigation is necessary to deal with the situation.
- If the prototype is large, a distorted model may be necessary. In a distorted model the vertical model scale is usually smaller than the horizontal scale.
- A movable bed model may be necessary if a significant 3-dimensional variation of sediment movement occurs in the prototype. Since movable bed model results are difficult to interpret, it can be advantageous to first investigate general flow variations in a fixed bed model.
- The verification of model results is absolutely necessary. Model results are usually verified with at least three flow conditions: high, medium, and low flow.
- In order to design a river model study correctly, one must decide the purpose of the model tests, know the principles of modeling thoroughly, and also have a thorough technical knowledge of hydraulics and river mechanics.

FHWA's "River Engineering for Highway Encroachments" (HDS 6)⁽⁴⁾ provides additional discussion of similitude for rigid-boundary and mobile-bed models.

A 1998 investigation of European practice for bridge scour and stream instability countermeasures⁽³²⁾ concluded that in Europe it is much more likely that physical modeling, often in conjunction with computer modeling, will be used as an integral part of the hydraulic design process for bridge foundations and countermeasures than we are accustomed to in the United States. Government research agencies and private sector laboratories (e.g., Delft Hydraulics in the Netherlands) maintain extensive physical modeling capabilities for the following reasons: validation of computer modeling, fundamental research with respect to physical processes, and solving problems for which computers cannot presently be applied.

In a report on testing the effectiveness of scour countermeasures by physical modeling, the Federal Waterways Engineering and Research Institute (BAW) in Karlsruhe, Germany notes that the physical modeling of the scouring process at bridge piers is a proven method to get information about the size of the scour and the flow velocities generating the scour. On the basis of this information, appropriate countermeasures can be designed. The advantage of the physical model is its application on even the most complex pier geometries.⁽³³⁾

At BAW, model tests were conducted for the piers of a new bridge over the Rhine River near Mannheim, Germany (Figure 4.1). Soon after the driving of sheet pile as a formwork for the lower part of the pier (pier width 11 m (36 ft) below mean water level and 5.5 m (18 ft) above mean water level) severe scouring of the river bed ($d_{50} = 8$ mm) occurred. As a consequence, the stability of the sheet pile formwork was endangered. An emergency countermeasure of placing riprap of 15-45 cm (6-8 inches) diameter into the scour hole did not stop local scouring; however, an additional cover layer of coarser stones (diameter 20-60 cm [8 - 24 inches]) was placed on top of the previous layer, stopping the erosion process at mean flow. A series of model tests were conducted in order to estimate the durability and stability of the emergency countermeasure for flood events. The tests proved the riprap to be stable even at flood stage while the scour was shifted away from the pier to the margin between the riprap and the sand of the natural river bed.

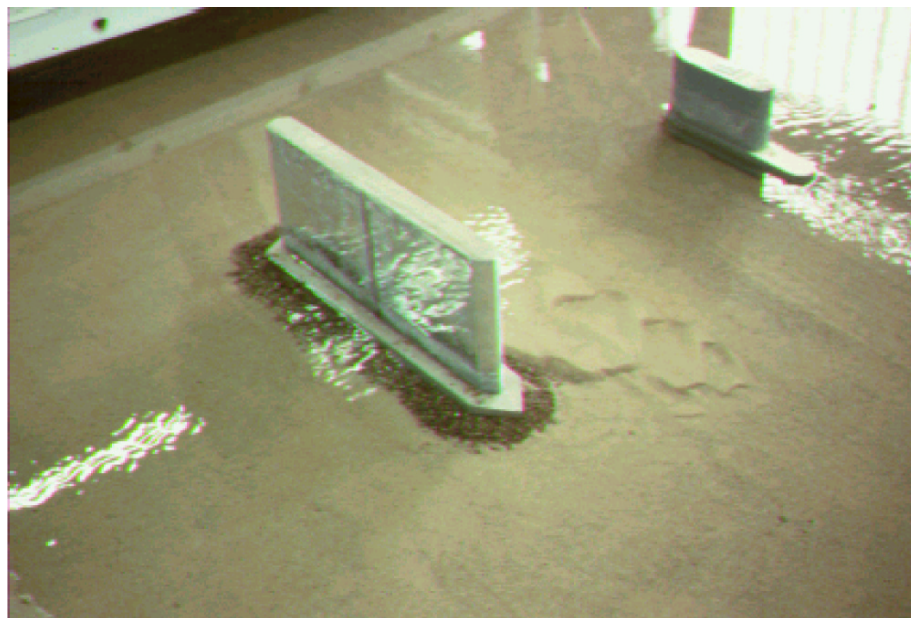

Figure 4.1. BAW laboratory, Karlsruhe, Germany, pier scour model of railway bridge over Rhine River near Mannheim.⁽³³⁾

4.3.3 Scour at Transverse Structures

Several commonly used countermeasures for channel instability or scour protection project transversely into the flow (e.g., spurs, dikes, and jetties) or intercept overbank flow as it returns to the main channel (e.g., guidebanks). Estimating scour at the nose of these structures is critical to successful design. Equation 4.1 is presented in HEC-18⁽²⁴⁾ as an alternative abutment scour equation when the projecting embankment/abutment length is large in relation to flow depth ($a/y_1 > 25$).

$$\frac{y_s}{y_1} = 4 F_r^{0.33} \quad (4.1)$$

where:

- y_s = Equilibrium depth of scour (measured from the mean bed level to the bottom of the scour hole), m (ft)
- y_1 = Average upstream flow depth in the main channel or on the overbank outside the influence of the structure, m (ft)
- a = Structure length projecting normal to the flow, m (ft)
- F_r = Upstream Froude Number outside the influence of the structure

This equation is based on field data on scour at the nose of rock spurs in the Mississippi River (obtained by the USACE) and is suggested here for estimating local scour at the nose of any transverse structure projecting into the flow.

For cases where the transverse structure length is small in comparison to flow depth ($a/y_1 \leq 25$) HDS 6⁽⁴⁾ (see "Highways in the River Environment," 1990 Edition) presents the following equation for local live-bed scour in sand at a stable spill slope when the flow is subcritical:

$$\frac{y_s}{y_1} = 1.1 \left(\frac{a}{y_1} \right)^{0.4} F_r^{0.33} \quad (4.2)$$

Where the variables are defined as for Equation 4.1. This equation is suggested here for estimating local scour at the nose of a transverse structure projecting into the flow when the conditions for Equation 4.1 are not met.

4.3.4 Scour at Longitudinal Structures

Variations in bed elevation during flow events or after bank hardening can result in the undermining of bank protection structures including longitudinal structures. Therefore, methods are needed for estimating maximum scour in order to design stable bank protection. The following sections provide methods for estimating scour along longitudinal countermeasures such as bulkheads and vertical walls.

Scour with Flow Parallel to a Vertical Wall. The probable mechanism causing scour along a vertical wall when the flow is parallel to the wall is an increase in boundary shear stress produced by locally increased velocity gradients that result from the reduced roughness of the vertical wall, as compared to the natural channel. It is reasonable to conclude that this scour will continue until the local flow area has increased enough to reduce the local velocity, and hence the local boundary shear stress, to values typical of the rest of the channel cross section.⁽³⁴⁾

The distribution of boundary shear stress around the perimeter of a channel is not constant. In channels of uniform roughness, the boundary shear stress has a maximum value near the channel centerline, and a secondary peak about one-third of the way up the sideslope. On average, the maximum on the bottom is about 0.97 times the average boundary shear stress (e.g., as defined by γRS) for the cross section and the maximum on the side is about 0.76 times the average boundary shear stress. However, experimental data indicate a range of values, with maximum shear stresses as much as 1.6 times the average. In general, the boundary shear stress distribution is more uniform as the width to depth ratio increases.

Similar information is not available for channel cross sections of nonuniform roughness; however, reasonable conclusions can be drawn from intuitive arguments. For a straight channel with a vertical wall with smoother roughness than the rest of the channel along one side, the boundary shear stress distribution would be skewed towards the wall side of the channel. The sideslope peak value would be larger and could possibly be greater than the peak along the channel bed, which would also be shifted off the centerline location. These effects would be more pronounced in narrow channels and/or channels with steep sideslopes. As the channel gets wider, or the sideslope flattens, these effects would be diminished.

Insight on the magnitude of these effects can be obtained by considering local velocity conditions as determined by conveyance weighting concepts (see HEC-18⁽²⁴⁾ and HEC-20⁽²³⁾). The analysis assumes that the boundary roughness within the channel can be divided into two distinct regions: one region defining the roughness of the channel and the other defining the roughness of the channel bottom (note that this division of roughness, while logical, is not always analytically useful as it can create numerical problems leading to errors in the computation of conveyance for the entire cross section).

For purposes of illustration, a wide, shallow natural channel has a uniform roughness with a Manning's n value of 0.03, but with a concrete vertical wall the n value of the bank region is reduced by a factor of two, to 0.015. Evaluation of the distribution of discharge by conveyance weighting shows that this reduction of "n" nearly doubles the conveyance, discharge, and velocity adjacent to the bank (i.e., next to the wall). Recognizing that boundary shear stress is proportional to velocity squared; this increase in velocity increases the boundary shear stress by a factor of 4.

Based on the experimental results for a uniform roughness channel, the maximum boundary shear stress along the vertical wall could be as much as 3 times the average boundary shear stress. However, this is not totally accurate given the simplistic assumptions made and the likely changes in the distribution pattern that would result under conditions produced by a vertical wall. Nonetheless, this simplified analysis suggests that significant increases in the boundary shear stress are possible adjacent to the wall.

To apply this concept, it is appropriate to define a shear stress multiplier that can be applied to the average boundary shear stress to define the locally increased boundary shear stress adjacent to a vertical wall. Based on the above argument, a shear stress factor of 3 is suggested. Recognizing that boundary shear stress is proportional to velocity squared, the reduction in velocity necessary to lower the shear stress to an acceptable value is defined by the inverse of the square root of the shear stress multiplier (0.577) for the shear stress factor of 3. For the reduction in velocity to occur, the flow area must then be increased by the inverse of this factor ($1/0.577 = 1.73$). For a vertical wall, this calculation simplifies to a unit width basis and the scour depth is a multiplier of the average flow depth ($0.73 y_1$).

It is important to understand that this provides a first approximation of the potential scour along a vertical wall due to flow parallel to the wall. Using this relation, the total scour along the wall due to parallel flow can be approximated as the sum of the above relation, which

results from a differential in shear stress, plus scour associated with the passage of antidunes (see HDS 6⁽⁴⁾). This results in the following relationship:⁽³⁴⁾

$$\frac{y_s}{y_1} = 0.73 + 0.14 \pi F_r^2 \quad (4.3)$$

where:

- y_s = Equilibrium depth of scour (measured from the mean bed level to the bottom of the scour hole), m (ft)
- y_1 = Average upstream flow depth in the main channel, m (ft)
- F_r = Upstream Froude Number

This equation is applicable only where parallel flow can be assured (e.g., vertical walls along both banks).

Scour with Flow Impinging at an Angle on a Vertical Wall. When an obstruction such as an abutment or vertical wall projects into the flow, the depth of scour at the nose or face of the obstruction can be estimated from Equation 4.1. Considering the physical configuration of the channels for which the data on which this relation is based, this can reasonably be assumed to be the upper limit of the scour that could be expected for flow along a vertical wall when the flow impinges on the wall at an approximately 90° angle. The total scour along a vertical wall, thus, will vary as a proportion of that given by Equations 4.1 and 4.3. Assuming that the relative significance of the two scour mechanisms is related to the change in momentum associated with the change in flow direction from some angle θ relative to the wall, the two relations can be combined using a weighting factor based on the sine or cosine, respectively, of the angle of the flow to the wall (0° to 90°). The resulting relationship is given by:⁽³⁴⁾

$$\frac{y_s}{y_1} = (0.73 + 0.14 \pi F_r^2) \text{Cos } \theta + 4 F_r^{0.33} \text{Sin } \theta \quad (4.4)$$

where:

- θ = Angle between the impinging flow direction and the vertical wall

Scour Along a Vertical Wall Relative to Unconstrained Valley Width. The potential scour that could occur along a vertical wall due to changes in planform as the channel evolves can be estimated by combining Equation 4.4 with the relationships for ideal meander geometry (see HEC-20⁽²³⁾). Using these relationships, it can be shown that the maximum angle will vary from zero, when the width of the valley is constrained to the width of the channel, to approximately 71°, when the unconstrained valley width is approximately 3.5 times the width of the channel. These values are based on the assumption that the meander wavelength is 14 times the channel width. The resulting dimensionless scour depth as a function of the unconstrained valley width is plotted in Figure 4.2 for a range of Froude Numbers (F_r).

It is possible for the channel to impinge perpendicular to the wall due to local flow deflection or other local factors. For this case, the angle of impingement is no longer related to the valley width, and the maximum scour depth can best be estimated based strictly on Equation 4.1.

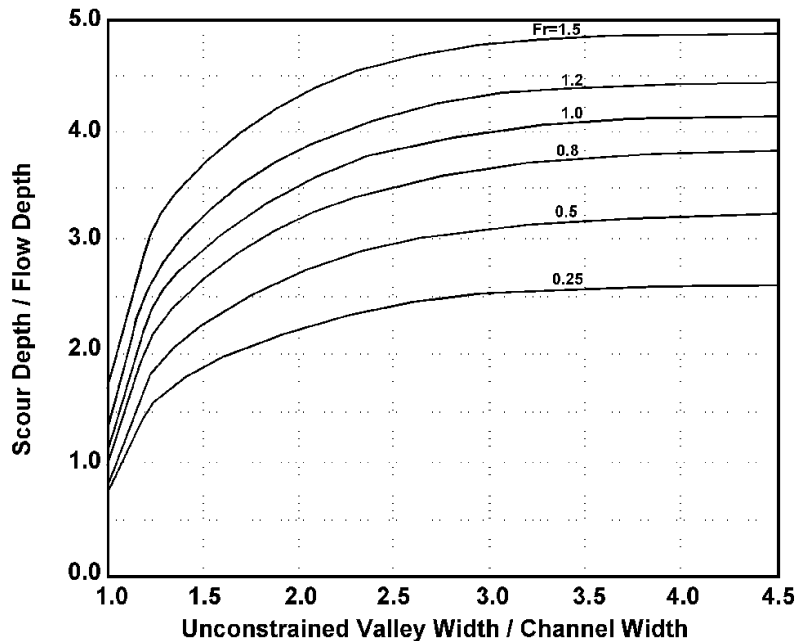

Figure 4.2. Scour along a vertical wall as a function of unconstrained valley width.⁽³⁴⁾

In using Figure 4.2, it is important to recognize that the relationships are based on an assumed ideal meander geometry and scour relationships that, while they are the best available, are very approximate. Considering the extreme local variability that can occur in a given stream and the approximate nature of the relationships upon which these results are based, engineering judgement is critical in evaluating the reasonableness of the results for a specific problem. In particular, the potential for flow deflection and its effect on the angle of impingement on the wall should be considered and a conservatively large angle applied in Equation 4.4. If there is any reasonable possibility of flow perpendicular to the wall, an angle of 90° (thus, Equation 4.1) is recommended. When the results of this analysis are used to design the burial depth for a vertical wall, a safety factor of at least 0.3 m (1 ft) should be added to the predicted scour depth.

4.3.5 Scour at Protected Bendways

Bend Scour. Deep sections at the toe of the outer bank of a bendway are the result of scour. High velocity along the outer bank is caused by secondary currents and greater outer-bank depths, and together with the resultant shear stress, produce scour and cause a difference between the sediment load entering and exiting the outer-bank zone. Since secondary currents transport sediment supplied, in large part, from outer bank erosion toward the inner bank of a bend, hardening of the outer bank by longitudinal bank protection structures may cause the channel cross section to narrow and deepen by preventing the recruitment of eroded outer bank sediments.

Experience is usually the most reliable means of estimating scour depth when designing a bank protection project for a particular stream. Lacking experience on a particular stream, scour depths may be estimated using physically based analytical models or empirical methods. Although scour-depth can be estimated analytically or empirically, empirical methods were generally found to provide better agreement with observed data.

Maynard⁽³⁵⁾ provides an empirical method for determining scour depths on a typical bendway bank protection project. Although his studies are restricted to sand bed streams, the Maynard method agrees reasonably well with the limited number of gravel-bed data points obtained by Thorne and Abt.⁽³⁶⁾ Nonetheless, the techniques presented by Maynard are restricted to meandering channels having naturally developed widths and depths, and cannot be applied to channels that have been confined to widths significantly less than a natural system.

Maynard's method of estimating scour depth is based on a regression analysis of 215 data points. The scour data used in developing his equation were measured at high discharges that were within the channel banks and had return intervals of 1-5 years. Maximum depth as defined in his best-fit equation for scour depth estimation is a function of R_c/W , width to depth ratio, and mean depth as follows:

$$\frac{D_{mxb}}{D_{mnc}} = 1.8 - 0.051 \left(\frac{R_c}{W} \right) + 0.0084 \left(\frac{W}{D_{mnc}} \right) \quad (4.5)$$

where:

- R_c = Centerline radius of the bend, m (ft)
- W = Width of the bend, m (ft)
- D_{mxb} = Maximum water depth in the bend, m (ft)
- D_{mnc} = Average water depth in the crossing upstream of the bend, m (ft)

The terms D_{mxb} and D_{mnc} are defined in Figure 4.3. Maynard's method includes incorporation of a safety factor of 1 to 1.19 that is dependent on the number of data points that are significantly unconservative. It is recommended that a safety factor of 2 be used with Equation 4.5.⁽³⁷⁾

The applicability of Maynard's equation is limited to streams with R_c/W from 1.5 to 10 and W/D_{mnc} from 20 to 125 because of the lack of data outside these ranges. He recommends that for channels with $R_c/W < 1.5$ or width to depth ratios less than 20, the scour depth for $R_c/W = 1.5$ and $W/D_{mnc} = 20$, respectively, be used.

In addition, Thorne and Abt⁽³⁶⁾ suggest these methods are valid until there is significant interaction between the main channel flow and overbank flow. Therefore, Maynard⁽³⁵⁾ recommends that application of these empirical methods to overbank flow conditions should be limited to overbank depth less than 20 percent of main channel depth.

Radial Stress. The ratio of bend radius of curvature to flow width provides insight into the force on the meander bend margin, but this parameter does not include discharge. A quantitative technique which considers a single-event discharge and an estimate of the radial stress on a meander bend margin was developed to evaluate the performance of alternative streambank erosion protection techniques for the U.S. Army Corps of Engineers, Vicksburg District.⁽³⁸⁾ This technique could also be used by highway engineers to evaluate alternative channel instability countermeasures for a bridge located in a meander bend.

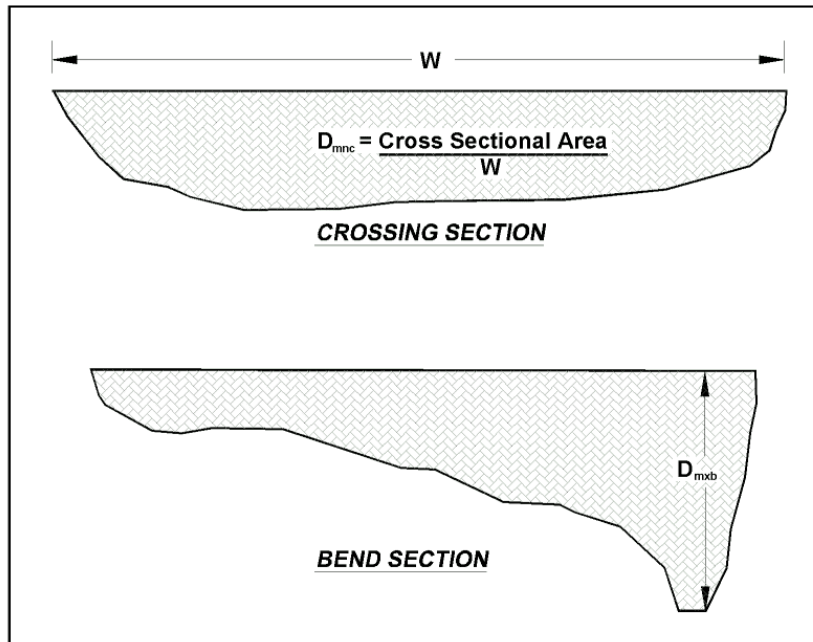

Figure 4.3. Definition sketch of width (W) and mean water depth (D_{mnc}) at the crossing upstream of the bend and maximum water depth in the bend (D_{mxb}).

Begin⁽³⁹⁾ defines radial stress as the centripetal force divided by the outer bank area. The centripetal force is responsible for deflecting the flow around the bend and is equal to the apparent reactive force of the flow on the bend. Based on this concept of centripetal force, the equation for the radial stress (ϕ_r) of flow on a meander bend is:

$$\phi_r = \frac{F}{A_b} = \frac{\rho QV}{Y(R_c + W/2)} \quad (4.6)$$

where:

- F = Centripetal force, N (lbs)
- A_b = Area of outer bank, m^2 (ft^2)
- ρ = Fluid density, kg/m^3 (lbs/ft^3)
- Q = Discharge, m^3/s (ft^3/s)
- V = Flow velocity, m/s (ft/s)
- Y = Mean flow depth, m (ft)
- R_c = Radius of curvature, m (ft)
- w = Topwidth, m (ft)

Thus, the radial stress is defined as a force per unit area (N/m^2 or lbs/ft^2). Although it is not suggested that the radial stress is directly responsible for meander bend migration or failure of bank protection countermeasures, Begin did show that the radial stress is related to meander migration.⁽³⁹⁾ It is assumed that shear stress is related to radial stress because of water surface superelevation and increased near-bank velocity gradients.

Field investigations and computation of radial stress on banklines for channels in the Yazoo River basin in Mississippi clearly showed that rudimentary countermeasures, such as used-tire revetment were generally unsuccessful in bends with even low to moderate radial stress.⁽³⁸⁾ The study also showed that stone structures including longitudinal stone dikes and stone spurs performed well in reaches of high radial stress. Isolated failures of stone structures did occur at locations with the highest radial stress. The 2-year storm discharge was used in the computations for radial stress at these sites.

For example, in a 1990 study, the South Fork Tillatoba Creek had the greatest variety of structures of any of the study streams and as shown in Figure 4.4, with the exception of the board fence dikes, the non-stone structures did not perform well. Of the stone structures, one peaked longitudinal stone dike failed at a site with high radial stress, resulting in bank erosion. Two board fence dikes performed well on meander bends with moderate radial stress. Figure 4.4 indicates that board fence dikes could have been used successfully at many of the locations where transverse stone dikes were used, and could have replaced at least two of the peaked and non-peaked longitudinal stone dikes. The figure clearly shows that used-tire revetment, tire- and hay bale-filled wire crib, sand-cement bag revetment, and cable fence dikes were generally unsuccessful even at low radial stress bends.

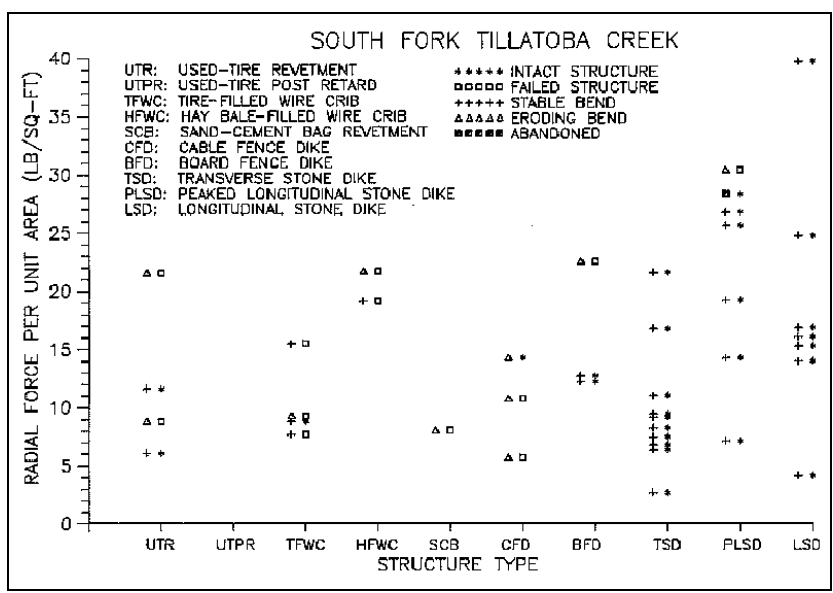

Figure 4.4. Relationship between radial stress and structure type for South Fork Tillatoba Creek, Mississippi, based on a 2-year return period discharge.⁽³⁸⁾

Although a variety of factors other than radial stress can affect structure performance and are not accounted for in this analysis, this relatively simple quantitative analysis technique can provide specific guidelines for evaluation and design of countermeasures against lateral channel instability. Comparing meander bend radial stress with structure performance helped explain structure failures and suggested that some bends, with moderate values of radial stress, might have been protected with less intensive (and less expensive) treatment. Thus, this analysis can potentially be used to rank meander bends to determine which are in greatest need of protection and what type of structure could provide adequate protection.

4.4 RIPRAP

4.4.1 Overview

Riprap consists of a layer or facing of rock, dumped or hand-placed on channel and structure boundaries to limit the effects of erosion. It is the most common type of countermeasure due to its general availability, ease of installation and relatively low cost. Any successful riprap design must account for several possible modes of failure. These included riprap particle erosion, substrate material erosion and mass failure. Riprap particle erosion is primarily limited by sizing the riprap to withstand hydraulic and turbulence forces, but is also be affected by riprap slope, impact and abrasion, ice, waves and vandalism. Substrate particle erosion occurs when the base material erodes and migrates through the riprap voids causing the riprap to settle. Substrate particle erosion is limited by placing a granular or geotextile filter between the riprap and the base material. Mass failure occurs when large sections of the riprap and/or base material slide or slump due to gravity forces. Mass failure can be caused by excess pore water pressures, bank steepness and loss of basal support through scour or channel migration. Also, a filter fabric that is too fine can block and cause the buildup of pore water pressures in the underlying soil.

Riprap that is large enough to resist all the hydraulic forces can fail if channel migration or scour undermines the toe support. When the riprap toe is undermined it can shift and remain functional to some degree. Often an extra volume of riprap is included at the toe for this purpose, or the riprap toe is trenched to the depth of potential degradation and contraction scour.

Graded riprap is more stable than uniform riprap because the range of sizes helps the riprap layer to interlock. Care must be taken during construction to ensure that the graded rocks are uniformly distributed. If large rocks roll to the base of the bank and the smaller rocks accumulate at the top, the benefits of using graded riprap will be lost. Also, a relatively uniform riprap surface will be more stable than an extremely uneven riprap surface.

Riprap design requires hydraulic, scour, and stream instability analyses as well as geotechnical investigations of channel and bank stability. Riprap placed at a pier can become ineffective if the underlying material washes through the riprap voids and the riprap settles. Pier riprap can fail if contraction scour or channel bed degradation causes the stones to launch and roll away from the pier. Abutment riprap can fail if channel migration undermines the toe support of the rock. Channel bank riprap can fail if excess pore pressures or toe scour produce a mechanically unstable bank. These failures could occur even if the riprap size was appropriate for the particular application.

Hydraulic Engineering Circular-11, "Design of Riprap Revetment" is FHWA's primary reference for riprap design.⁽³⁾ Design Guideline 12 provides a summary of HEC-11 recommendations in relation to revetment riprap design for countermeasures (spurs, guidebanks, etc.). Special design considerations for riprap at bridge piers and abutments are presented in Design Guideline 8. In addition to these references to the primary sources of design guidance on the use of riprap as a scour or channel instability countermeasure, this section contains insights derived from reviews of standard practice outside the United States regarding application of riprap and its alternatives as a countermeasure.

4.4.2 Turbulence Intensity

According to Hoffmans and Verheij⁽⁴⁰⁾ riprap can be sized using either the Isbash or Shields stability criteria if turbulence intensity is incorporated into the velocity component. The effect of turbulence is to increase instantaneous velocities well above the levels for unobstructed flow. This concept is particularly applicable to the pier riprap equations.

The standard Isbash formula for sizing riprap on a channel bed is:

$$D_{50} = \frac{0.692(KV)^2}{(2g(S_s - 1))} \quad (4.7)$$

where:

- D_{50} = Riprap size, m (ft)
- V = Velocity, m/s (ft/s)
- S_s = Specific gravity of the riprap (usually 2.65)
- K = 1.0

To incorporate the effects of turbulence intensity, Hoffmans and Verheij⁽⁴⁰⁾ recommend that the value of K be adjusted above a value of 1.0. In the specific case of circular piers, they recommend using the local velocity upstream of the pier and values of K up to 2.0. This amount of adjustment is equivalent to increasing shear stress by a factor of four.

This approach is similar to the equations presented in Design Guideline 8 and in the riprap sizing formula presented by Parola.⁽⁴¹⁾ The only difference is the recommended values of K in the design guideline are 1.5 for circular piers and 1.7 for square piers, and the recommended values of K by Parola ranged from 1.44 to 1.90 depending on pier and footing geometry and approach flow angle of attack.

4.4.3 Grouted and Partially Grouted Riprap

The following discussion on grouted riprap is adapted from HEC-11⁽³⁾ and the Transportation Research Board.⁽³²⁾ Grouted riprap is rock slope paving with voids filled with concrete grout forming a monolithic armor. Because grouted riprap is a rigid structure, it will not conform to bank settlement or toe undermining as loose riprap does. Therefore, grouted riprap is susceptible to mass failure, especially if pore water is not allowed to drain properly. Although the revetment is rigid, it is not particularly strong and even a small loss of toe or bank support can result in the failure of large portions of the structure.

The primary advantage of grouted riprap is that the grout anchors the rock and eliminates particle erosion of the revetment. Therefore, smaller rock can be used for the revetment, and the total thickness of the revetment can be reduced as compared with traditional riprap revetment. Another advantage is that a relatively smooth surface can be achieved and, therefore, the hydraulic efficiency of the waterway is improved. Filters are not required for fully grouted riprap but drainage of pore water must be provided. A significant disadvantage of fully grouted riprap is that a complete layer of grout converts a flexible revetment to a rigid cover, subject to the potential problems of any rigid slope paving, including undercutting at the toe, out flanking, and the possibility of catastrophic failure.

An alternative to grouted riprap is partially grouted riprap. In general, the objective is to increase the stability of the riprap without sacrificing all of the flexibility. Partial grouting of riprap may be well suited for areas where rock of sufficient size is not available to construct a loose riprap revetment.

The River and Channel Revetments design manual recently published by H.R. Wallingford in the United Kingdom⁽⁴²⁾ provides design guidance for grouting "hand pitched stone" with both bituminous and cement grout. For grouting riprap in the United Kingdom, bitumen is the material most commonly used. Although various degrees of grouting are possible, effective solutions are usually produced when the bituminous mortar envelopes the loose stone and leaves relatively large voids between rock particles. The degrees of bituminous grouting available are:

- Surface grouting (which does not penetrate the whole thickness of the revetment and corresponds to about one-third of the voids filled)
- Various forms of pattern grouting (where only some of the surface area of the revetment is filled, between 50 to 80 percent of voids)
- Full grouting (an impermeable type of revetment)

Partial grouting of riprap with a cement slurry is presented as one of several standard design approaches for permeable revetments in a discussion of considerations regarding the experience and design of German inland waterways.⁽⁴³⁾ The grout is placed on the riprap leaving significant voids in the riprap matrix and considerable open space on the surface. Most of the grout is in the upper one-third of the riprap layer with significant amounts of grout in the center one-third and relatively little grout in the lower one-third. Assuming that the riprap occupies approximately 60 percent of the total volume, the remaining 40 percent of the space should be three parts grout to one part void in the upper third, equal amounts of grout and void in the middle third and one part grout to three parts void in the lower third of the riprap layer (Figure 4.5).

The holes in the grout allow for drainage of pore water so a filter is required. The grout forms conglomerates of riprap so the stability against particle erosion is greatly improved and, as with fully grouted riprap, a smaller thickness of stone can be used (Figure 4.6). Although not as flexible as riprap, partially grouted riprap will conform somewhat to bank settlement and toe exposure.

An important consideration for partially grouted riprap is that construction methods must be closely monitored to insure that the appropriate voids and surface openings are provided. Contractors in Germany have developed techniques and equipment to achieve the desired grout coverage and the right penetration. Various European countries have developed special grout mixes and construction methods for underwater installation of partially grouted riprap.⁽³²⁾

4.4.4 Armor Units

Three-dimensional concrete armor units can be used in place of riprap and are distinguished from block or grout filled mattresses by the fact that they do not form a veneer over the protected area. An example of a 3-dimensional armor unit is Toskanes (see Design Guide 6) which are concrete units with some interlocking capabilities. As with articulating block mattress, the design of armor units relies on access to standards developed from laboratory hydraulic testing conducted for the manufacturer. Without this information there can be no assurance that the armor unit layer will survive the hydraulic stresses.



Figure 4.5. Partially grouted riprap undergoing testing at the Federal Waterway Engineering and Research Institute (BAW), Karlsruhe, Germany.⁽⁴³⁾



Figure 4.6. "Conglomerate" of partially grouted riprap, Federal Waterway Engineering and Research Institute, Karlsruhe, Germany.⁽⁴³⁾

Armor units can be placed individually (as with the Toskanes) or in interconnected groups. The groups can be assembled and interconnected off-site and placed en masse with a crane or can be assembled at the location requiring protection and interconnected as a final step. Filter layers or bedding material may also be required to achieve the desired hydraulic performance (see Design Guideline 6).

As with any countermeasure, the armor units must withstand several potential failure modes. Providing resistance against the hydraulic stresses may not be sufficient for structure success. If the armor units are used to counter pier scour, they must also remain stable for channel degradation, contraction scour, and the passage of bed forms (dunes). If armor units are used as bank revetment, then the stability of the bank must be analyzed for potential toe scour, pore water pressures and saturated soil strengths.

4.4.5 Concrete Prisms and Cubes

As an alternative to small interlocking 3-dimensional armor units, large concrete prisms or cubes have been used effectively for bank protection. In Switzerland,⁽⁴⁴⁾ laboratory testing resulted in the design of massive precast concrete armor units (prisms) for a site-specific countermeasure installation. Similarly, in New Zealand,⁽⁴⁵⁾ concrete cubes have been used to provide a countermeasure against channel bank erosion at bridges. These techniques are highlighted below.

In Switzerland the floods of August 24-25, 1987 caused considerable damage in the Reuss River valley near Wassen, in Uri Canton. The Swiss experienced a near catastrophic failure of a major national highway bridge when the Reuss River migrated laterally and undermined the foundation of a bridge pier (Figure 4.7). The countermeasure system developed by the Laboratory of Hydraulics, Hydrology, and Glaciology/Swiss Federal Institute (VAW/ETH) included a pile wall in front of the bridge piers, five concrete spurs, large concrete groins, and the placement of about 175 precast concrete prisms to correct and prevent further channel migration or lateral erosion.

The river bank between the groins was protected by the precast concrete prisms, triangular in cross section, placed individually as revetment. In lieu of smaller interlocking armor units that would be costly to fabricate, the decision was made to cast much larger prisms with a simple shape and use the mass of the prisms to protect against river bank scour. The precast, hollow prisms were filled with concrete after they were placed in their final position. The groin field and prism revetment were then covered with a layer of natural stone for aesthetic and environmental reasons (Figure 4.8).⁽⁴⁴⁾

Concrete cubes were used to control bank erosion on the Waimakariri River in New Zealand (Figure 4.9). These concrete cubes were 1.22 m (4.0 ft) on each side with rails through two or three axes that extended approximately 1 m (3 ft) from the sides. Rebar "eye-bolts" were also projected from several sides so the cubes could be tethered together with the cable terminated at a deadman buried in the channel bank. Although no design criteria are available, the cube mass and rails make the cubes very stable. These cubes appeared to have been in place for many years on this active braided mountain channel.⁽⁴⁵⁾



Figure 4.7. Reuss River bridge failure near Wassen, Uri Canton Switzerland, August 1987.⁽⁴⁴⁾



Figure 4.8. Massive precast concrete prisms placed as a groin field, Switzerland.⁽⁴⁴⁾



Figure 4.9. Concrete cube bank revetment, Waimakariri River, New Zealand.⁽⁴⁵⁾

4.4.6 Installation Techniques

In Europe, riprap is considered an effective and permanent countermeasure against channel instability and scour, including local scour at bridge piers. Considerable effort has been devoted to techniques for determining size, gradation, layer thickness and horizontal extent, filters, and placement techniques and equipment for riverine and coastal applications.⁽³²⁾ Engineers in Europe emphasize the need for designing the riprap for a specific site, and in many cases a hydraulic model study will be performed to verify riprap stability (see Section 4.3.2 and Figure 4.1). The intensity of turbulence in relation to the structure to be protected is analyzed to assist in developing the most economical riprap design, with larger rock being specified for areas of high turbulence (see Section 4.4.2).

Great care is taken in placing the riprap at critical locations, and in many cases stones are placed individually in the riprap matrix. Highly specialized equipment has been developed by construction contractors in Europe for placing riprap, particularly for coastal installations. The use of bottom dump or side dump pontoons (barges) is common in both Germany and the Netherlands. By loading pontoon "bins" selectively with different sizes of rock, a design gradation in the riprap can be achieved. For large installations, vessels for placing riprap are equipped with dynamic positioning systems using Differential Global Positioning System technology and thrusters to maintain position, and echo sounders (or divers) to verify the coverage of the riprap layer. Some of the smaller pontoon systems, particularly the bottom dump pontoons developed in Germany could be used to place riprap in water at larger bridges (Figure 4.10).



Figure 4.10. Bottom dump pontoon barge used in Germany for placing riprap.⁽³²⁾

4.5 FILTER REQUIREMENTS

4.5.1 Overview

Granular or geosynthetic filters are essential to the performance of hydraulic countermeasures, especially armoring countermeasures. Filters prevent soil erosion beneath the armoring material, prevent migration of fine soil particles through voids in the armoring material, distribute the weight of the armor units to provide a more uniform settlement, and permit relief of hydrostatic pressure within the soils. Experience has indicated that the proper design of filters is critical to the stability of revetments. If openings in the filter material are too large, excessive piping through the filter can result in erosion of the subgrade beneath the armor. Conversely, if openings in the filter are too small, hydrostatic pressures can build up in the underlying soil and result in failure of the countermeasure. Guidelines for the selection, design, and specifications of filter material can be found in HEC-11⁽³⁾ (see Design Guideline 12), and detailed information on the use of geosynthetic filters can be found in Holtz et al. (FHWA HI-95-038).⁽⁴⁶⁾ The State of California Department of Transportation also provides guidance on the use of geotextile filters with slope protection measures.⁽⁴⁷⁾ The following paragraphs illustrate several additional filter concepts from current European practice.

4.5.2 Fascine Mats

In Europe, fascine mats, a very old, traditional approach for scour protection, are currently used to assist in the placement of a geotextile filter. While the fascine alone will not function as a filter,⁽⁴³⁾ it provides a means of placing a geotextile filter in deep water. The fascines consist of a matrix of willow or other natural material woven in long bundles (15- to 20-cm [6 to 8 in.] in diameter) to form a matrix which is assembled over a layer of woven geotextile (Figure 4.11). The geotextile has ties which permit fastening it to the fascine mat. The fascine mattress, sometimes called a "sinker mat" is floated into position and sunk into place by dropping riprap on it from a barge. Fascine sinker mats and riprap have been used to protect the toe of the riprap installation at a major storm surge barrier in Germany and for coastal applications in the Netherlands.⁽³²⁾



Figure 4.11. Fascine mattress: Fascine bundles tied on a base of woven geosynthetic fabric.⁽⁴³⁾

4.5.3 Geotextile Containers

In Europe, a significant investment has been made in the development and testing of geosynthetic materials, and innovative installation techniques have been developed that could find application for bridge pier and abutment countermeasures in the United States. Highly specialized laboratory equipment is available for testing a wide range of geotextile characteristics, including: (1) impact test (to determine punching resistance, e.g., when large stone is dropped on the geotextile); (2) abrasion test; (3) permeability, clay clogging, and sand clogging tests; and (4) tests of material characteristics such as elongation and strength. Through this testing program, geotextile materials have been developed that permit innovative approaches to filter placement for riprap and other countermeasures.⁽³²⁾

Because of the extensive testing program in Europe, geotextile filters can be manufactured with consistent quality and in accordance with the requirements of a specific application. The wide choice in synthetics also allows the use of an inert material which will not interact with the environment. While the filtration capacity of a woven geotextiles is restricted to narrowly graded grain size distributions, a non-woven fabric can be designed for nearly any given grain size distribution of the subsoil. It is also possible to combine a woven and a nonwoven geotextiles to combine, for example, good filtration capacity with high strength. The main function of geosynthetics in scour countermeasures is that of a filter, but they also can be used as containment or as reinforcement.⁽⁴³⁾

Geotextile containers (large sand bags) made of mechanically bonded non-woven fabrics up to 1.25 cubic meters (44 ft³) in volume have been used to provide a filter layer for riprap installation at several large projects in Germany (Figure 4.12). The containers are sewn on three sides at a factory and filled on-site to approximately 80 percent of capacity with sand/gravel filter material using a hopper system. The final seam is sewn on site. The containers are placed in layers using a side-dump pontoon on bottom dump split barge. The elongation capabilities of the fabric and partial filling allow the containers to adjust to irregularities of the substrate at the installation site. Riprap is then placed over the layer of geotextile containers.

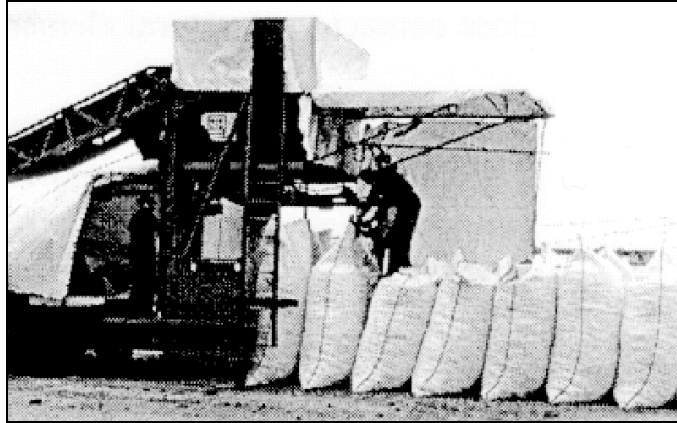

Figure 4.12. Batch plant for filling numerous geotextile containers on-site.⁽⁴³⁾

Since geotextile containers are designed as filters for a specific subsoil, it is essential that there are no gaps between the single container elements. Usually at least two layers of containers are required. Figure 4.13 illustrates a typical installation of two layers of geotextile containers and partially grouted riprap as a pier scour countermeasure. Thus, geocontainers are multi-purpose elements. They can be manufactured according to size, shape, filtration capacity, and strength. According to the demands of a specific site, only a few containers may be necessary, or many may be required.⁽⁴³⁾

To obtain a perfect filter, the fill of a geocontainer should be graded according to grain filter rules. The grain filter in a container may also be of a well graded and/or a widely graded grain size distribution, since no segregation will take place when dumping such filter material in containers. Such filter layers work well even when some elements are damaged. As noted, experience has shown that containers should be filled not more than 80 percent of the theoretical content to ensure a good adaptation to the ground and to the neighboring element. The choice of a non-woven geotextile will minimize the risk of damage during dumping due to its high strain capacity. By allowing large deformations, containers will be able to withstand the shock load with the ground and the impact of stones dumped upon the containers. With geotextile containers, a very reliable scour repair or protection can be achieved at individual bridge piers or on major projects such as coastal protection works.⁽⁴³⁾

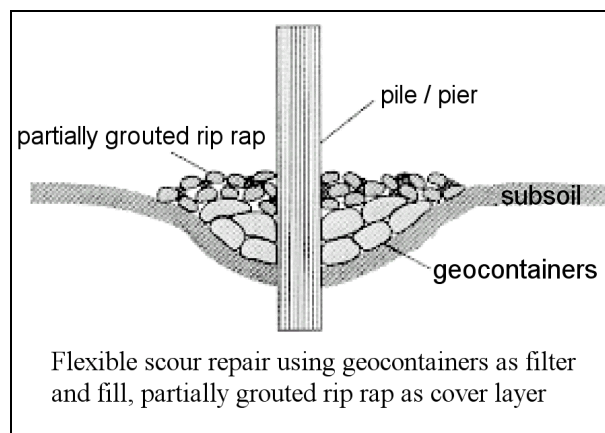

Figure 4.13. Schematic of pier scour repair using geocontainers as filter and fill, and partially grouted riprap as cover layer.⁽⁴³⁾

4.6 EDGE TREATMENT

Undermining of the edges of armoring countermeasures is one of the primary mechanisms of failure. The edges of the armoring material (head, toe, and flanks) should be designed so that undermining will not occur. For channel bed armoring, this is accomplished by keying the edges into the subgrade to a depth which extends below the combined expected contraction scour and long-term degradation depth. For side slope protection, this is achieved by trenching the toe of the revetment below the channel bed to a depth which extends below the combined expected contraction scour and long-term degradation depth. When excavation to the contraction scour and degradation depth is impractical, a launching apron can be used to provide enough volume of rock to launch into the channel while maintaining sufficient protection of the exposed portion of the bank. Continuous systems, such as articulating concrete block systems and grout filled mattresses applied on side slopes, should be designed with an apron or toe trench so that the system provides protection below the combined expected contraction scour and long-term degradation depth. Tension anchors may be used to increase stability at the edges of these continuous systems. Additional guidelines on edge treatment for armoring countermeasures can be found in Design Guideline 12 and HEC-11.⁽³⁾

4.7 BIOTECHNICAL ENGINEERING

4.7.1 Overview

Vegetation has been used increasingly over the past few decades to control streambank erosion or as a bank stabilizer. It has been used primarily in stream restoration and rehabilitation projects and can be applied independently or in combination with structural countermeasures. There are several synonymous terms that describe the field of vegetative streambank stabilization and countermeasures. Terms for the use of 'soft' revetments (consisting solely of living plant materials or plant products) include bioengineering, soil bioengineering, ground bioengineering, and ecological bioengineering. Terms describing the techniques that combine the use of vegetation with structural (hard) elements include biotechnical engineering, biotechnical slope protection, bioengineered slope stabilization, and biotechnical revetment. The terms soil bioengineering and biotechnical engineering are most commonly used to describe stream bank erosion countermeasures and bank stabilization methods that incorporate vegetation.

The effective application of soil bioengineering and biotechnical engineering techniques requires expertise in channel and watershed processes, biology, and streambank stabilization techniques. Due to a lack of technical training and experience, there is a reluctance to resort to soil bioengineering and biotechnical engineering techniques and stability methods. In addition, bank stabilization systems using vegetation have not been standardized for general application under particular flow conditions. There is a lack of knowledge about the properties of the materials being used in relation to force and stress generated by flowing water and there are difficulties in obtaining consistent performance from countermeasures that rely on living materials.

Stabilization of eroding stream banks using vegetative countermeasures has proven effective in many documented cases in Europe and the United States. However, the use of soil bioengineering and biotechnical engineering with respect to scour and stream instability at highway bridges is a relatively new field. There is research being conducted in these fields, but these techniques have generally not been tested specifically as a countermeasure to protect bridges in the river environment.

Most hydraulic engineers in Europe would not recommend the reliance on bioengineering countermeasures as the only countermeasure technique when there is a risk of damage to property or a structure, or where there is potential for loss of life if the countermeasure fails. Soil bioengineering is not suitable where flow velocities exceed the strength of the bank material or where pore water pressure causes failures in the lower bank. In contrast, biotechnical engineering is particularly suitable where some sort of engineered structural solution is required, but the risk associated with using just vegetation is considered too high. Nonetheless, this group of countermeasures is not as well accepted as the classical engineering approaches to bridge stability.⁽³²⁾

Design of biotechnically engineered countermeasures to minimize rates of stream bank erosion requires accounting for hydrologic, hydraulic, geomorphic, geotechnical, vegetative, and construction factors. Although most of the literature dealing with biotechnical engineering on rivers is associated with stream bank stabilization relative to channel restoration and rehabilitation projects, it is also generally applicable to bank stabilization associated with bridge crossings. Bentrup and Hoag,⁽⁴⁸⁾ Johnson and Stypula,⁽⁴⁹⁾ U.S. Army Engineer Waterways Experiment Station,⁽⁵⁰⁾ and the Federal Interagency Stream Restoration Working Group⁽⁵¹⁾ provide detailed guidelines, techniques, and methods of biotechnical engineering for bank stabilization in the United States. Guidelines, methodology, and design of biotechnically engineered streambank stabilization in Europe and the United Kingdom are discussed in Schiechl and Stern,⁽⁵²⁾ Morgan et al.,⁽⁵³⁾ and Escarameia.⁽⁴²⁾

4.7.2 Advantages and Disadvantages of Biotechnical Engineering

Specific ways vegetation can protect stream banks as part of a biotechnical engineering approach include:

- The root system binds soil particles together and increases the overall stability and shear strength of the bank.
- The exposed vegetation increases surface roughness and reduces local flow velocities close to the bank, which reduces the transport capacity and shear stress near the bank, thereby inducing sediment deposition.
- Vegetation dissipates the kinetic energy of falling raindrops, and depletes soil water by uptake and transpiration.
- Vegetation reduces surface runoff through increased retention of water on the surface and increases groundwater recharge.
- Vegetation deflects high-velocity flow away from the bank and acts as a buffer against the abrasive effect of transported material.
- Vegetation improves the conditions for fisheries and wildlife and helps improve water quality.

In addition, biotechnical engineering is often less expensive than most methods that are entirely structural and it is often less expensive to construct and maintain when considered over the long-term.

The critical threats to the successful performance of biotechnical engineering projects are improper site assessment, design or installation, and lack of monitoring and maintenance (especially following floods and during droughts). Some of the specific limitations to the use of vegetation for streambank erosion control include:

- Lack of design criteria and knowledge about properties of vegetative materials
- Lack of long-term quantitative monitoring and performance assessment
- Difficulty in obtaining consistent performance from countermeasures relying on live materials
- Possible failure to grow and susceptibility to drought conditions
- Depredation by wildlife or livestock
- It may require significant maintenance

More importantly, the type of plants that can survive at various submersions during the normal cycle of low, medium, and high stream flows is critical to the design, implementation, and success of biotechnical engineering techniques.

4.7.3 Design Considerations for Biotechnical Engineering

In an unstable watershed, careful study should be made of the causes of instability before biotechnical engineering is contemplated (see HEC-20,⁽²³⁾ Chapter 4, Reconnaissance Classification, and Response). Since bank erosion is tied to channel stability, a stable channel bed must be achieved before the banks are addressed. Scour and erosion of the bank toe produce the dominant failure modes (see HEC-20⁽²³⁾), consequently, most biotechnical engineering projects documented in the literature contain some form of structural (hard) toe stabilization, such as rock riprap (Figure 4.14), rock gabions, cribs, cable anchored logs, or logs with root wads anchored by boulders (Figure 4.15). Note the use of a fascine bundle in Figure 4.14 as part of the rock toe protection (see Section 4.5.2). Toe protection should be keyed into the channel bed sufficiently deep to withstand significant scour and the biotechnically engineered revetment should be keyed into the bank at both the upstream and downstream ends (called refusals) to prevent flanking. Deflectors such as fences, dikes, and pilings may also be utilized to deflect flow away from the bankline.

Other factors that need to be considered when selecting a design option include climate and hydrology, soils, cross-sectional dimensions (is there sufficient room for the countermeasure), flow depth, flow velocity (both magnitude and direction), and slope of the bankline being protected. Most methods of biotechnical engineering will require some amount of bank regrading. Because structure design is based on flood velocities and depths, one or more design flows will need to be analyzed. Of particular interest is the bankfull or overtopping event, since this event generates the greatest velocities and tractive forces. Local (at or near the project site) flow velocities should be used for the design, especially along the outside of bends. The erosion protection should extend far enough downstream, particularly on the outer banks of bends. The highest velocities generally occur at the downstream arc of a bend and on the outer bank of the exit reach immediately downstream. As noted, the countermeasures should be tied into the bank at both ends to prevent flanking.

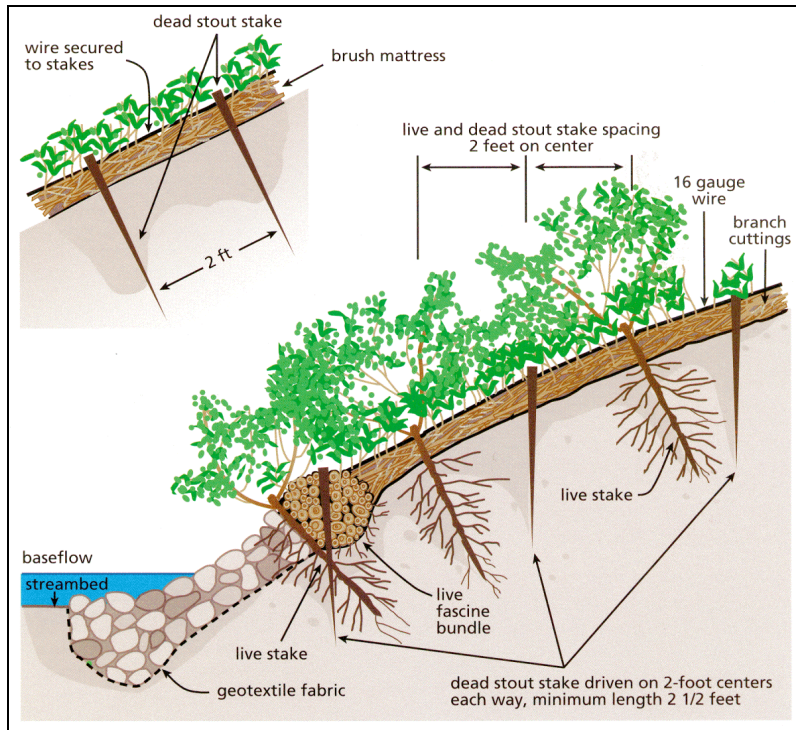

Figure 4.14. Details of brush mattress technique with stone toe protection.⁽⁵¹⁾

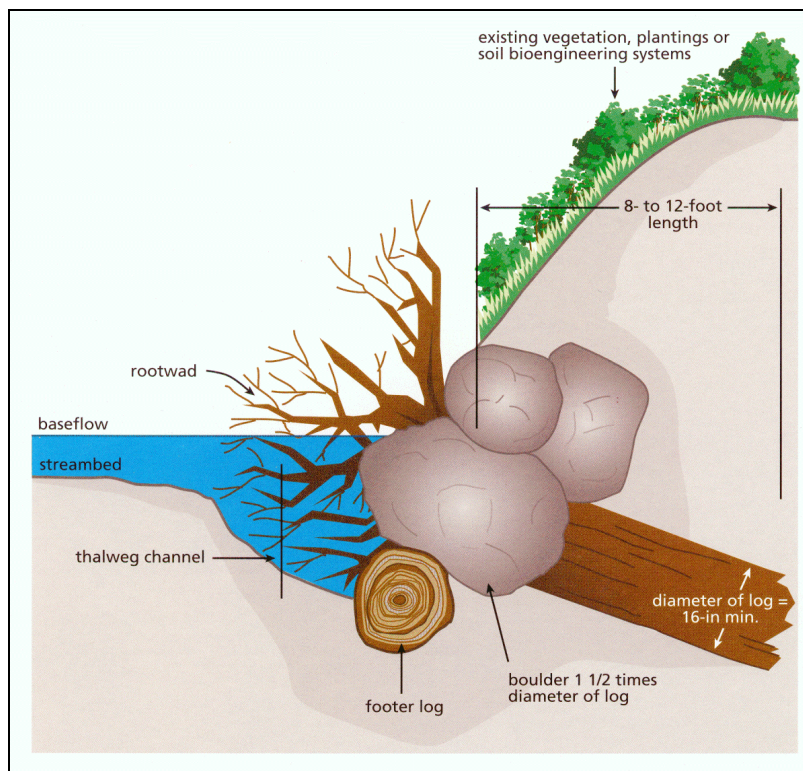

Figure 4.15. Details of rootwad and boulder revetment technique.⁽⁵¹⁾

4.7.4 Streambank Zones

As indicated by U.S. Army Engineer Waterways Experiment Station (WES),⁽⁵⁰⁾ plants should be positioned in various elevational zones of the bank based on their ability to tolerate certain frequencies and durations of flooding, and their attributes of dissipating current- and wave-energies. The stream bank is generally broken into three or four zones to facilitate prescription of the biotechnical erosion control treatment. Because of daily and seasonal variations in flow, the zones are not precise and distinct. The zones are based on their bank position and are defined as the toe, splash, bank and overbank zones (Figure 4.16).

The *toe zone* is the area between the bed and the average normal stage. This zone is often under water more than six months of the year. It is a zone of high stress and is susceptible to undercutting and scour resulting in bank failure.

The *splash zone* is located between the normal high-water and normal low-water stages and is inundated throughout much of the year (at least six months). Water depths fluctuate daily, seasonally, and by location within the zone. This zone is also an area of high stress, being exposed frequently to wave-wash, erosive currents, ice and debris movement, wet-dry cycles, and freeze-thaw cycles.

Because the toe and splash zones are the zones of highest stress, these zones are treated as one zone with a structural revetment, such as rock, stone, logs, cribs, gabions, or some other 'hard' treatment. Within the splash zone, flood-resistant herbaceous emergent aquatic plants like reeds, rushes, and sedges may be planted in the structural element of the bank protection.

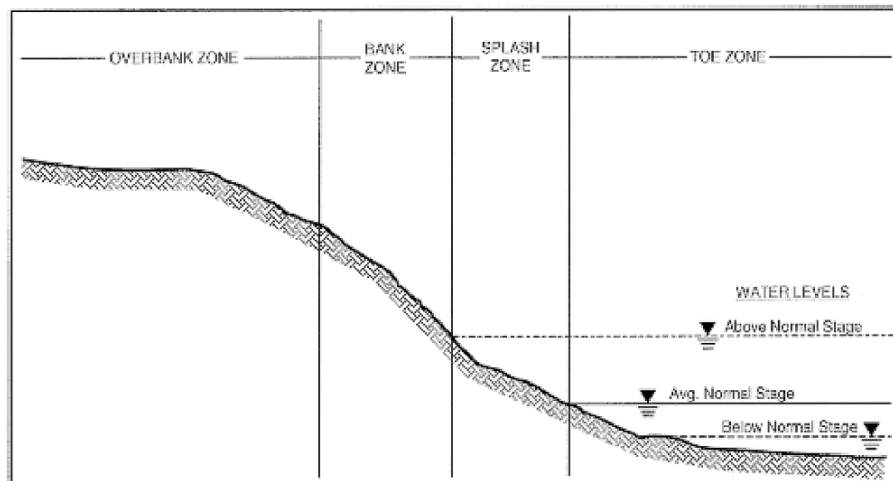

Figure 4.16. Bank zones defined for slope protection.⁽⁵⁰⁾

The *bank zone* is usually located above the normal high-water level, but is exposed periodically to wave-wash, erosive flows, ice and debris movement, and traffic by animals or man. This zone is inundated for at least a 60-day duration once every two to three years and is influenced by a shallow water table. Herbaceous (i.e., grasses, clovers, some sedges, and other herbs) and woody plants (i.e., willows, alder, and dogwood) that are flood tolerant and able to withstand partial to complete submergence for up to several weeks are used in this zone. Whitlow and Harris⁽⁵⁴⁾ provide a listing of very flood-tolerant woody species and a few herbaceous species by geographic area within the United States.

The *overbank zone* includes the top bank area and the area inland from the bank zone, and is usually not subjected to erosive forces except during occasional flooding. Vegetation in this zone is extremely important for intercepting overbank floodwater, binding the soil in the upper bank together through its root system, helping reduce super-saturation of the bank, and decreasing the weight of unstable banks through evapotranspiration processes. This zone can contain grasses, herbs, shrubs, and trees that are less flood-tolerant than those in the bank zone. The rooting depth of trees can be an extremely important part of bank stability. Besides erosion control, wildlife habitat diversity, aesthetics, and access for project construction and long-term maintenance are important considerations in this zone.

4.7.5 Biotechnical Engineering Treatments

Descriptions and guidelines for biotechnical engineering treatments or combinations of treatments, and plant species that can be used in the treatments are described in detail by WES,⁽⁵⁰⁾ Bentrup and Hoag,⁽⁴⁸⁾ and Schiechl and Stern.⁽⁵²⁾ The following is a brief summary of some of the major types of biotechnical engineering treatments that can be used separately or in some combination.

Toe Zone. Structural revetments such as riprap, gabions, cribs, logs, or rootwads in a biotechnical engineering application are used at the toe in the zone below normal water levels and up to where normal water levels occur. There are no definitive guidelines for how far up the bank to extend the structural revetment. Instead, it is common practice to extend the revetment from below the predicted contraction and local scour depth up to at least where the water flows the majority of the year. Vegetative treatments are placed above or behind this structural toe protection.

Splash Zone. Several treatments may be used individually or in combination with other treatments in the splash zone above or behind the structural toe protection. These include coir rolls and mats, brush mattresses, wattles or fascines, brush layering, vegetative geogrid, dormant posts, dormant cuttings, and root pads.

Coir is a biodegradable geotextile fabric made of woven fibers of coconut husks and is formed into either rolls (coir roll) or mats (coir fiber mats). Coir rolls are often placed above the structural toe protection parallel to the bank with wetland vegetation planted or grown in the roll. Coir fiber mats are made in various thicknesses and are often prevegetated at a nursery with emergent aquatic plants or sometimes sprigged on-site with emergent aquatic plants harvested from local sources.

Brush mattresses, sometimes called brush matting or brush barriers, are a combination of a thick layer of long, interlaced live willow switches or branches and wattling. Wattling, also known as fascine, is a cigar-shaped bundle of live, shrubby material made from species that root rapidly from the stem. The branches in the mattress are placed perpendicular to the bank with their basal ends inserted into a trench at the bottom of the slope in the splash zone, just above the structural toe protection. The fascines are laid over the basal ends of the brush mattress in the ditch and staked. The mattress and fascines are kept in place by either woven wire or tie wire that is held in place by wedge-shaped construction stakes. Both are covered with soil and tamped. Figure 4.14 shows an example of this type of treatment.

Brush layering, also called branch layering or branch packing, is used in the splash zone as well as in the bank zone. This treatment consists of live branches or brush that quickly sprout, such as willow or dogwood species, placed in trenches dug into the slope, on contour, with their basal ends pointed inward and the tips extending beyond the fill face. Branches should be arranged in a criss-cross fashion and covered with firmly compacted soil. This treatment can also be used in combination with live fascines and live pegs.

Vegetative geogrid is also used in the splash zone and can extend farther up into the bank zone and possibly the overbank zone. This system is also referred to as "fabric encapsulated soil" and consists of successive walls of several lifts of fabric reinforcement with intervening long, live willow whips. The fabric consists of two layers of coir fabric which provide both structural strength and resistance to piping of fine sediments.

Dormant post treatment consists of placing dormant, but living stems of woody species that sprout stems and roots from the stem, such as willow or cottonwood, in the splash zone and the lower part of the bank zone. Post holes are formed in the bank so that the end of the post is below the maximum predicted scour depth. Posts can also be planted in riprap revetments.

Dormant cuttings, also known as live stakes, consists of inserting and tamping live, single stem, rootable cuttings into the ground or sometimes geotextile substrates. In the splash zone of high velocity streams, this method is used in combination with other treatments, such as brush mattresses and root wads. Dormant cuttings can be used as live stakes in the brush mattress and fascines in the place of or in combination with the wedge-shaped construction stakes (Figure 4.14).

Root pads are clumps of shrubbery composed of woody species that are often placed in the splash zone between root wads (Figure 4.15). Root pads can also be used in the bank and overbank zones, but should be secured with stakes on slopes greater than 1V:6H.

Bank Zone. This zone can be stabilized with the treatments previously described as well as with sodding, mulching, or a combination of treatments. Sodding of flood-tolerant grasses can be used to provide rapid bank stabilization where only mild currents and wave action are expected. The sod usually must be held in place with some sort of wire mesh, geotextile mesh such as a coir fabric, or stakes. Coir mats may extend into this zone. Shrub-like woody transplants or rooted cuttings are also effective in this zone and are often placed in combination with tied-down and staked mulch that is used to temporarily reduce surface erosion. For areas where severe erosion or high currents are expected, methods such as brush mattress should be carried into the bank zone.

Contour wattling consists of fascines, often used independent of the brush mattress, placed along contours, and buried across the slope, parallel or nearly parallel to the stream course. The bundles can be living or constructed from wood and are staked to the bank. Contour wattles are often installed in combination with a coir fiber blanket over seed and a straw mulch to prevent the development of rills or gullies.⁽⁵⁰⁾

Brush layering with some modifications can be used in the bank zone. Geotextile fabrics should be used between the brush layers and keyed into each branch layer trench to prevent unraveling of the bank between the layers.⁽⁵⁰⁾

Overbank Zone. Bioengineered treatments are generally not used in this zone except to control gullying or where slopes are greater than 1V:3H. In these cases, brush layering or contour wattling may be employed across the gully or on the contour of the slope.

Deep-rooting plants, such as larger flood-tolerant trees, are required in this zone in order to hold the bank together. Care should be taken in the placement of trees that may grow to be fairly large since their shade can kill out vegetation in the splash and bank zones. Trees planted in the overbank zone are planted either as container-grown or bare-root plants.

Depending on their shade tolerance, grasses, herbs, and shrubs can be planted between the trees. Hydroseeding and hydromulching are useful and effective means of direct seeding in the overbank zone.

4.7.6 Summary

Biotechnical engineering can be a useful and cost-effective tool in controlling bank erosion or providing bank stability at highway bridges, while increasing the aesthetics and habitat diversity of the site. However, where failure of the countermeasure could lead to failure of the bridge or highway structure, the only acceptable solution may be traditional, "hard" engineering approaches. Biotechnical engineering needs to be applied in a prudent manner, in conjunction with channel planform and bed stability-analysis, and rigorous engineering design. Designs must account for a multitude of factors associated with the geotechnical characteristics of the site, the local and watershed geomorphology, local soils, plant biology, hydrology, and site hydraulics. Finally, programs for monitoring and maintenance, which are essential to the success and effectiveness of any biotechnical engineering project, must be included in the project and strictly adhered to.

CHAPTER 5

COUNTERMEASURE DESIGN GUIDELINES

5.1 INTRODUCTION

Following Chapter 8, design guidelines are provided for a variety of stream instability and bridge scour countermeasures. Most of these countermeasures have been applied successfully on a state or regional basis, but, in several cases, only limited design references are available in published handbooks, manuals, or reports. No attempt has been made to include in this document design guidelines for all the countermeasures listed in the matrix (Table 2.1). There are, however, references in the matrix to publications that contain at least a sketch or photograph of a particular countermeasure, and in many cases contain more detailed design guidelines.

Countermeasure design guidelines formerly presented in HEC-20⁽²³⁾ (spurs, guide banks, drop structures) and in HEC-18⁽²⁴⁾ (riprap at abutments and piers) are now consolidated in this document as Design Guidelines 8-11. Since many bridge scour and stream instability countermeasures require revetment riprap as an integral component of the countermeasure, revetment riprap design guidance from HEC-11⁽³⁾ is summarized in Design Guideline 12.

As noted, FHWA has two additional publications dealing with stream instability and bridge scour countermeasures. "River Engineering for Highway Encroachments" (HDS 6),⁽⁴⁾ and HEC-11 "Design of Riprap Revetment"⁽³⁾ contain the following design guidance.

- Riprap stability factor design - HDS 6
- General revetment design - HEC-11

Reference to these documents is suggested for design guidelines on these countermeasures. For guidelines on the use of geotextiles for filters for countermeasures see Holz et al. FHWA HI-95-038.⁽⁴⁶⁾

A number of highway agencies provided specifications, procedures, or design guidelines for bridge scour and stream instability countermeasures that have been used successfully locally, but for which only limited design guidance is available outside the agency. Several of these are presented as design guidelines for the consideration of and possible adaptation to the needs of other highway agencies (see for example, Design Guideline 3, wire enclosed riprap mattress, and Design Guideline 7, grout cement filled bags). These specifications, procedures, or guidelines have not been evaluated, tested, or endorsed by the authors of this document or by the FHWA. They are presented here in the interests of information transfer on countermeasures that **may** have application in another state or region.

5.2 DESIGN GUIDELINES

The following specifications, procedures, or design guidelines are included following Chapter 8. The application of the countermeasure and the contributing source(s) of information are also indicated below.

Design Guideline 1

- **Bendway Weirs/Stream Barbs**
 - **Source(s):** Colorado Department of Transportation
Washington State Department of Transportation
Tennessee Department of Transportation
Soil Conservation Service (now Natural Resources Conservation Service)
U.S. Army Corps of Engineers
 - **Application:** Bankline protection and flow alignment in meandering channel bends

Design Guideline 2

- **Soil Cement**
 - **Source(s):** Portland Cement Association
Pima County Arizona
Maricopa County Arizona
 - **Application:** Revetment for banklines and sloping abutments

Design Guideline 3

- **Wire Enclosed Riprap Mattress (Railbank or Rock Sausage)**
 - **Source(s):** New Mexico State Highway and Transportation Department
 - **Application:** Revetment for banklines, guide banks, and sloping abutments

Design Guideline 4

- **Articulated Concrete Block System**
 - **Source(s):** Hydro Review
ASCE Hydraulic Engineering
Federal Highway Administration
Maine Department of Transportation
Minnesota Department of Transportation
 - **Application 1:** Bankline and abutment revetment and bed armor
 - **Application 2:** Pier scour protection

Design Guideline 5

- **Grout Filled Mattresses**
 - **Source(s):** Oregon Department of Transportation
Arizona Department of Transportation
 - **Application:** Bankline and abutment revetment and bed armor

Design Guideline 6

- **Concrete Armor Units**
 - **Source(s):** Pennsylvania Department of Transportation
Toskanes tested at Colorado State University (CSU)
A-Jacks Testing Manual (CSU)
A-Jacks Design Manual (Ayres Associates)
 - **Application:** Pier scour protection

Design Guideline 7

- **Grout/Cement Filled Bags**
 - **Source(s):** Maryland State Highway Administration
Maine Department of Transportation
 - **Application:** Protection of undermined areas at pier and abutments

Design Guideline 8

- **Rock Riprap at Piers and Abutments**
 - **Source(s):** HEC-18 Scour at Bridges (Third Edition)
 - **Application:** Pier and Abutment Scour Protection

Design Guideline 9

- **Spurs**
 - **Source(s):** HEC-20 Stream Stability at Highway Structures (Second Edition)
 - **Application:** Bankline stabilization and flow alignment

Design Guideline 10

- **Guide Banks**
 - **Source(s):** HEC-20 Stream Stability at Highway Structures (Second Edition)
 - **Application:** Abutment protection

Design Guideline 11

- **Check Dams/Drop Structures**
 - **Source(s):** HEC-20 Stream Stability at Highway Structures (Second Edition)
HEC-14 Hydraulic Design of Energy Dissipators for Culverts and Channels
 - **Application:** Correcting or preventing channel degradation

Design Guideline 12

- **Revetments**
 - **Source(s):** HEC-11 Design of Riprap Revetment
 - **Application:** Bankline/abutment protection and riprap component of many other countermeasures

(page left intentionally blank)

CHAPTER 6

OTHER COUNTERMEASURES AND CASE HISTORIES OF PERFORMANCE

6.1 INTRODUCTION

Design Guidelines 1 through 12 contain specific design procedures for a variety of stream instability and bridge scour countermeasures that have been applied successfully on a state or regional basis. Other countermeasures such as retarder structures, longitudinal dikes, bulkheads, and even channel relocations may be used to mitigate scour at bridges or stream bank erosion. Some of these measures are discussed and general guidance is summarized in this chapter. Chapter 4 (Section 4.3.5) illustrates the use of the concept of radial stress on a meander bend to evaluate the performance of fence, dike, and retarder type structures in protecting an eroding bankline.

Case histories of hydraulic problems at bridge sites can provide information on the success (or failure) of the various countermeasures used to stabilize streams. This chapter also summarizes the evaluation of countermeasure performance compiled for FHWA from case histories at 224 bridge sites.⁽¹²⁾

6.2 HARDPOINTS

Hardpoints consist of stone fills spaced along an eroding bank line, protruding only short distances into the channel. A root section extends landward to preclude flanking. The crown elevation of hardpoints used by the USACE at demonstration sites on the Missouri River was generally at the normal water surface elevation at the toe, sloping up at a rate of about 1 m in 10 m (1 ft in 10 ft) toward the bank. Hardpoints are most effective along straight or relatively flat convex banks where the streamlines are parallel to the bank lines and velocities are not greater than 3 m/s (10 ft/s) within 15 m (50 ft) of the bank line. Hardpoints may be appropriate for use in long, straight reaches where bank erosion occurs mainly from a wandering thalweg at lower flow rates. They would not be effective in halting or reversing bank erosion in a meander bend unless they were closely spaced, in which case spurs, retarder structures, or bank revetment would probably cost less. Figure 6.1 is a perspective of a hardpoint installation. Hardpoints have been used effectively as the first "spur" in a spur field (see Design Guideline 9).

6.3 RETARDER STRUCTURES

Retarder structures are permeable or impermeable devices generally placed parallel to streambanks to reduce velocities and cause deposition near the bank. They are best suited for protecting low banks or the lower portions of streambanks. Retarder structures can be used to protect an existing bank line or to establish a different flow path or alignment. Retards do not require grading of the streambank, and they create an environment which is favorable to the establishment of vegetation.

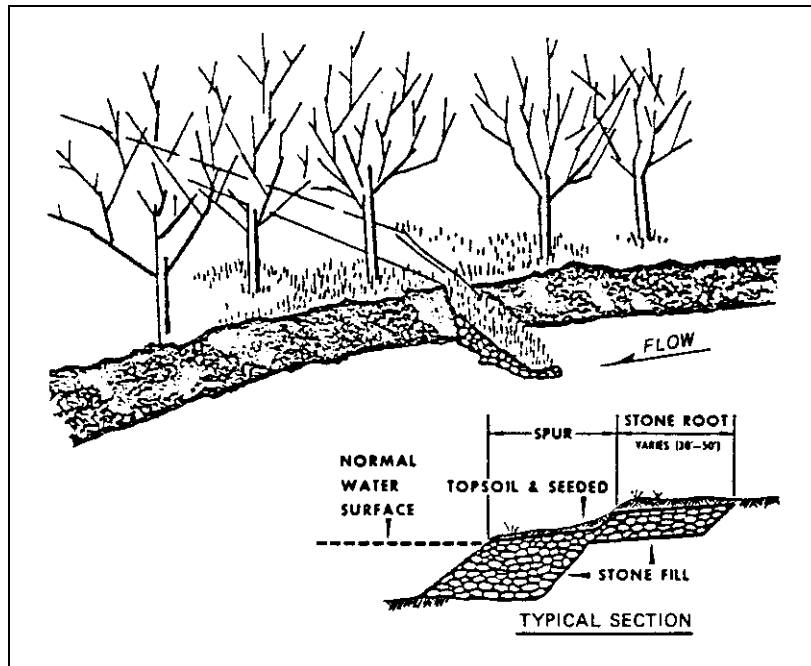

Figure 6.1. Perspective view of hardpoint installation with section detail (after Brown).⁽²⁾

6.3.1 Jacks and Tetrahedrons

Jacks most commonly consist of three linear members fixed together at their midpoints so that each member is perpendicular to the other two. Wires are strung on the members to resist distortion and to collect debris. Cables are used to tie individual jacks together and for anchoring key units to deadmen. Tetrahedrons consist of six members of equal length fixed together so as to form three faces, each of which is an equilateral triangle, i.e, a tetrahedron. The tetrahedron unit may be braced as shown in Figure 6.2 and wire mesh added to enhance flow retardance. Tetrahedrons are not as widely used as are jacks.

Jacks and tetrahedrons are effective in protecting banks from erosion only if light debris collects on the structures thereby enhancing their performance in retarding flow. However, heavy debris and ice can damage the structures severely. They are most effective on mild bends and in wide, shallow streams which carry a large sediment load.

Where jacks are used to stabilize meandering streams, both lateral and longitudinal rows are often installed to form an area retarder structure rather than a linear structure. Lateral rows of jacks are usually oriented in a downstream direction from 45° to 70°. Spacing of the lateral rows of jacks may be 15 to 75 m (50 to 200 ft) depending on the debris and sediment load carried by the stream. A typical jack unit is shown in Figure 6.3 and a typical area installation is shown in Figure 6.4.

Outflanking of jack installations is a common problem. Adequate transitions should be provided between the upstream bank and the structure, and the jack field should be extended to the overbank area to retard flow velocities and provide additional anchorage. Jacks are not recommended for use in corrosive environments or at locations where they would constitute a hazard to recreational use of the stream.

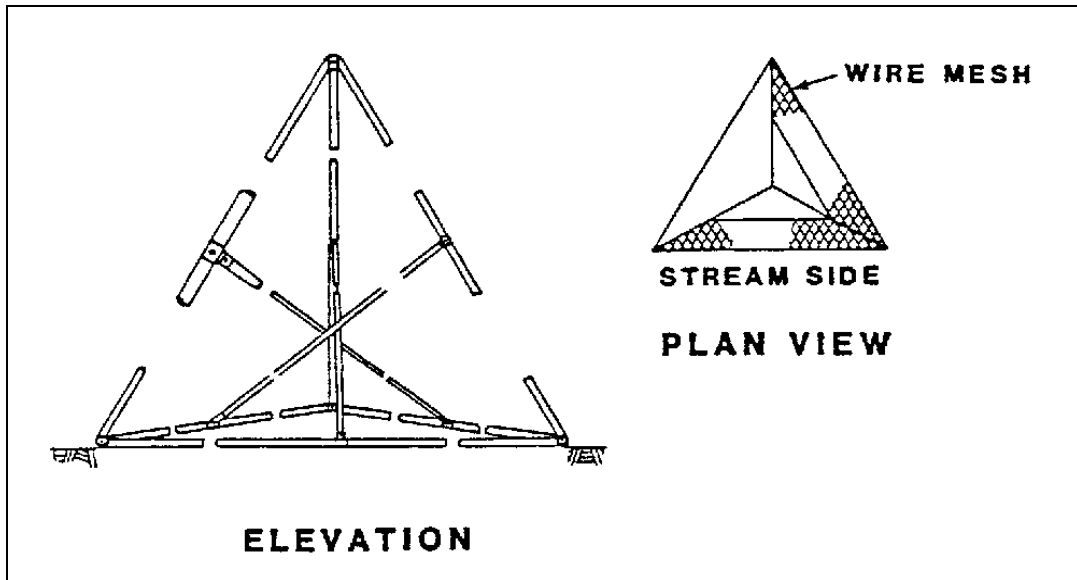

Figure 6.2. Typical tetrahedron design (after Brown).⁽²⁾

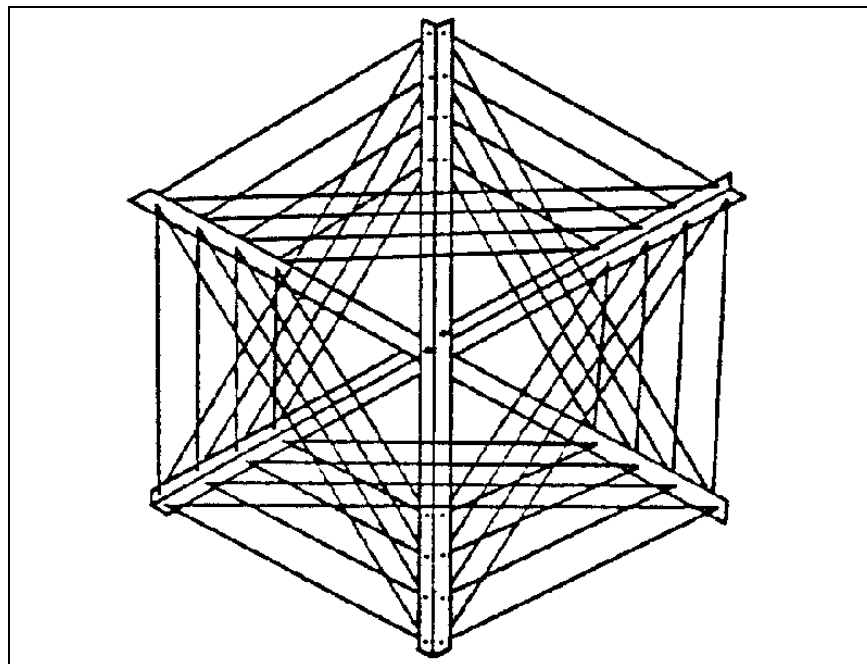

Figure 6.3. Typical jack unit (after Brown).⁽²⁾

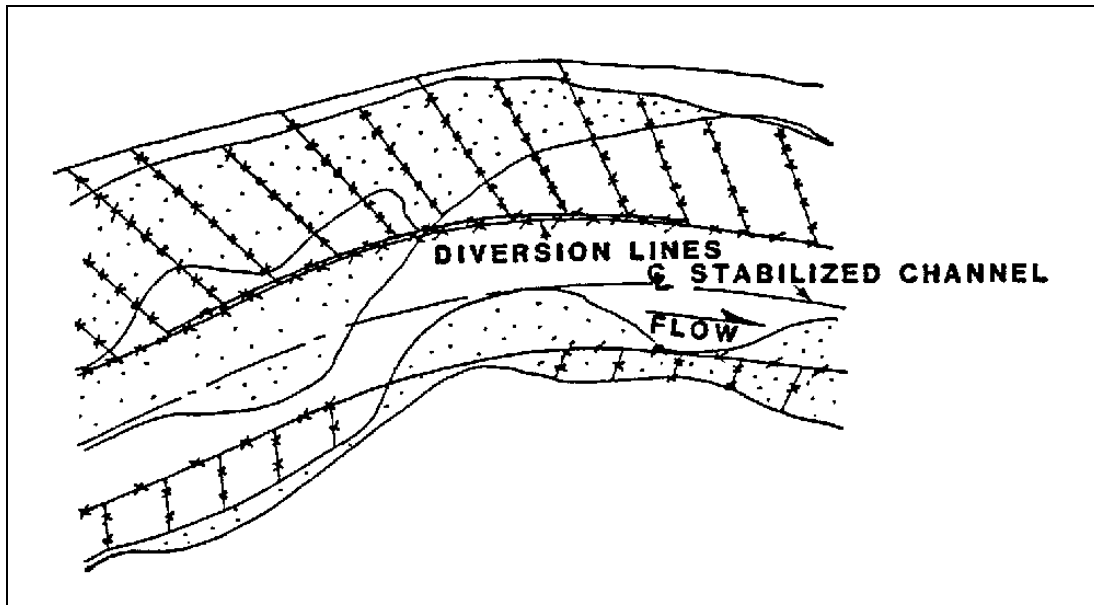

Figure 6.4. Retarder field schematic (after HDS 6).⁽⁴⁾

6.3.2 Fence Retarder Structures

Fence retarder structures provide protection to the lower portions of banks of relatively small streams. Posts may be of wood, steel, or concrete and fencing may be composed of wood planks or wire.

Scour and the development of flow channels behind linear structures are common causes of failure of longitudinal fences. Scour at the supporting members of the structure can be reduced by placing rock along the fence or the effects of scour can be overcome by driving supporting members to depths below expected scour. Tiebacks can be used to retard velocities between the linear structure and the streambank, thus reducing the ability of the stream to develop flow channels behind the structure.

6.3.3 Timber Pile

Timber pile retarder structures may be of a single, double, or triple row of piles with the outside of the upstream row faced with wire mesh or other fencing material. They have been found to be effective at sharp bends in the channel and where flows are directly attacking a bank. They are effective in streams which carry heavy debris and ice loads and where barges or other shipping vessels could damage other countermeasures or a bridge. As with other retarder structures, protection against scour failure is essential. Figure 6.5 illustrates a design.

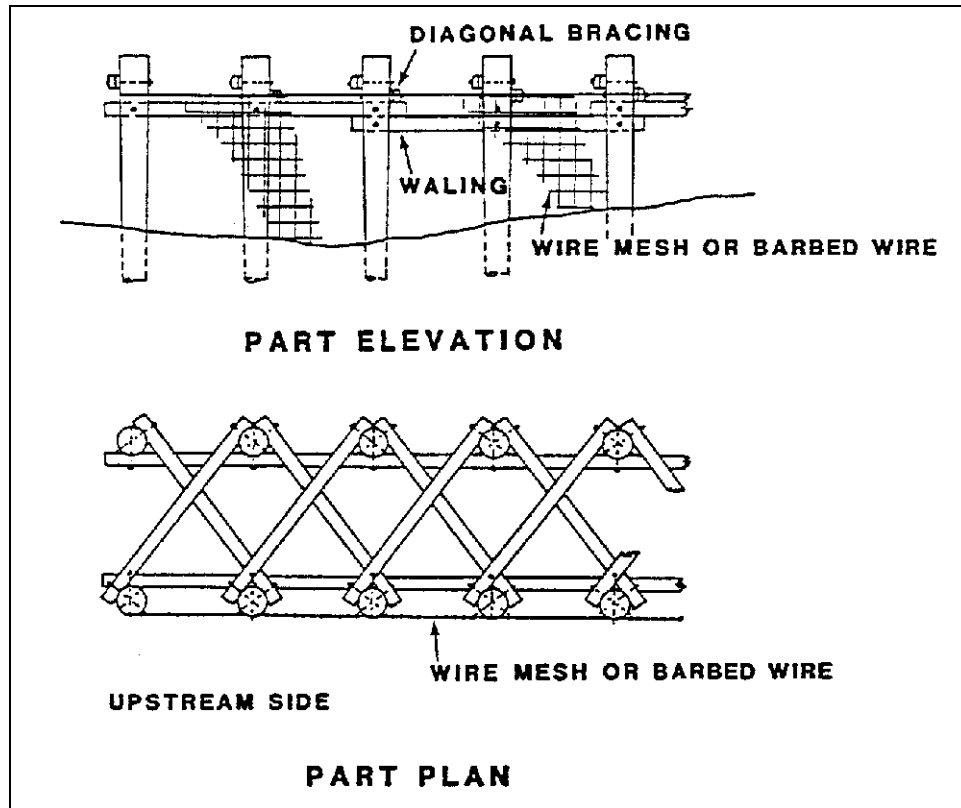

Figure 6.5. Timber pile bent retarder structure (Modified from California Department of Public Works, 1970 (after Brown).⁽²⁾)

6.3.4 Wood Fence

Wood fence retarder structures have been found to provide a more positive action in maintaining an existing flow alignment and to be more effective in preventing lateral erosion at sharp bends than other retarder structures. Figure 6.6 is an end view of a typical wood fence design with rock provided to protect against scour.

Wire fence retarder structures may be of linear or area configuration, and linear configurations may be of single or multiple fence rows. Double-row fence retards are sometimes filled with brush to increase the flow retardance. Figures 6.7 and 6.8 illustrate two types of wire fence retarder structures.

6.4 LONGITUDINAL DIKES

Longitudinal dikes are essentially impermeable linear structures constructed parallel with the streambank or along the desired flow path. They protect the streambank in a bend by moving the flow current away from the bank. Longitudinal dikes may be classified as earth or rock embankment dikes, crib dikes, or rock toe-dikes.

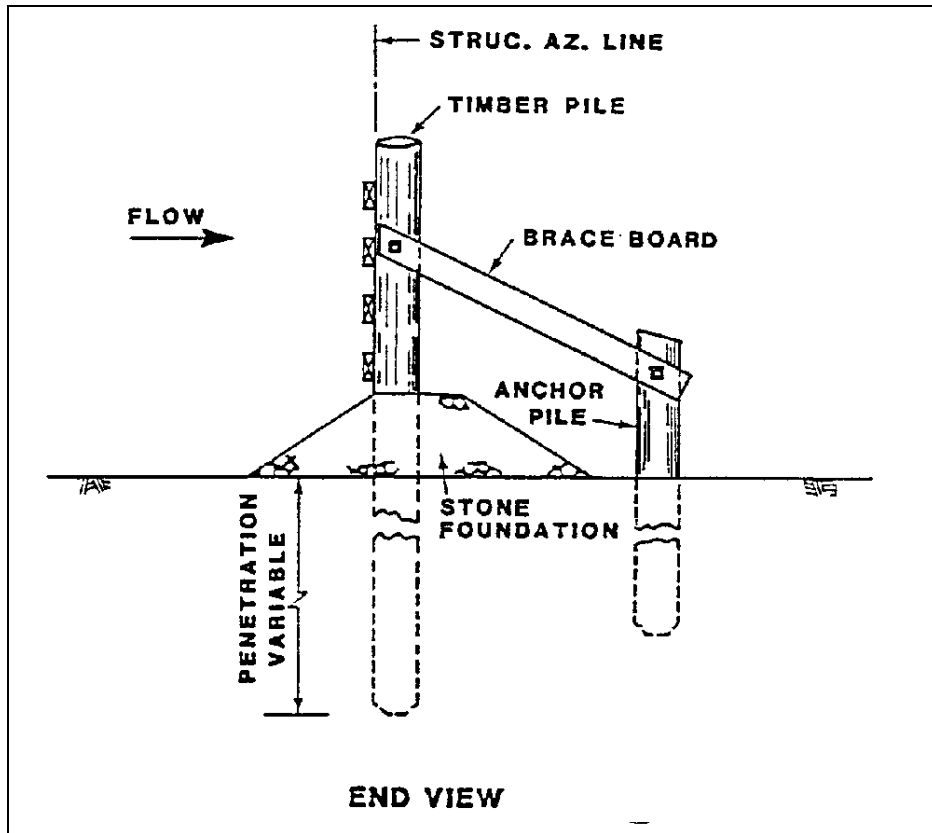

Figure 6.6. Typical wood fence retarder structure (modified from USACE 1981, after Brown).⁽²⁾

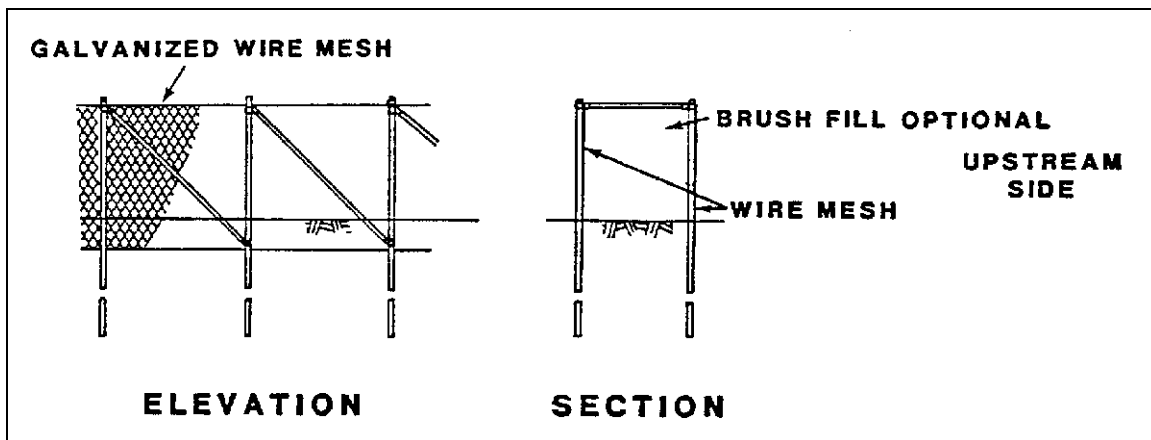

Figure 6.7. Light double row wire fence retarder structure (after Brown).⁽²⁾

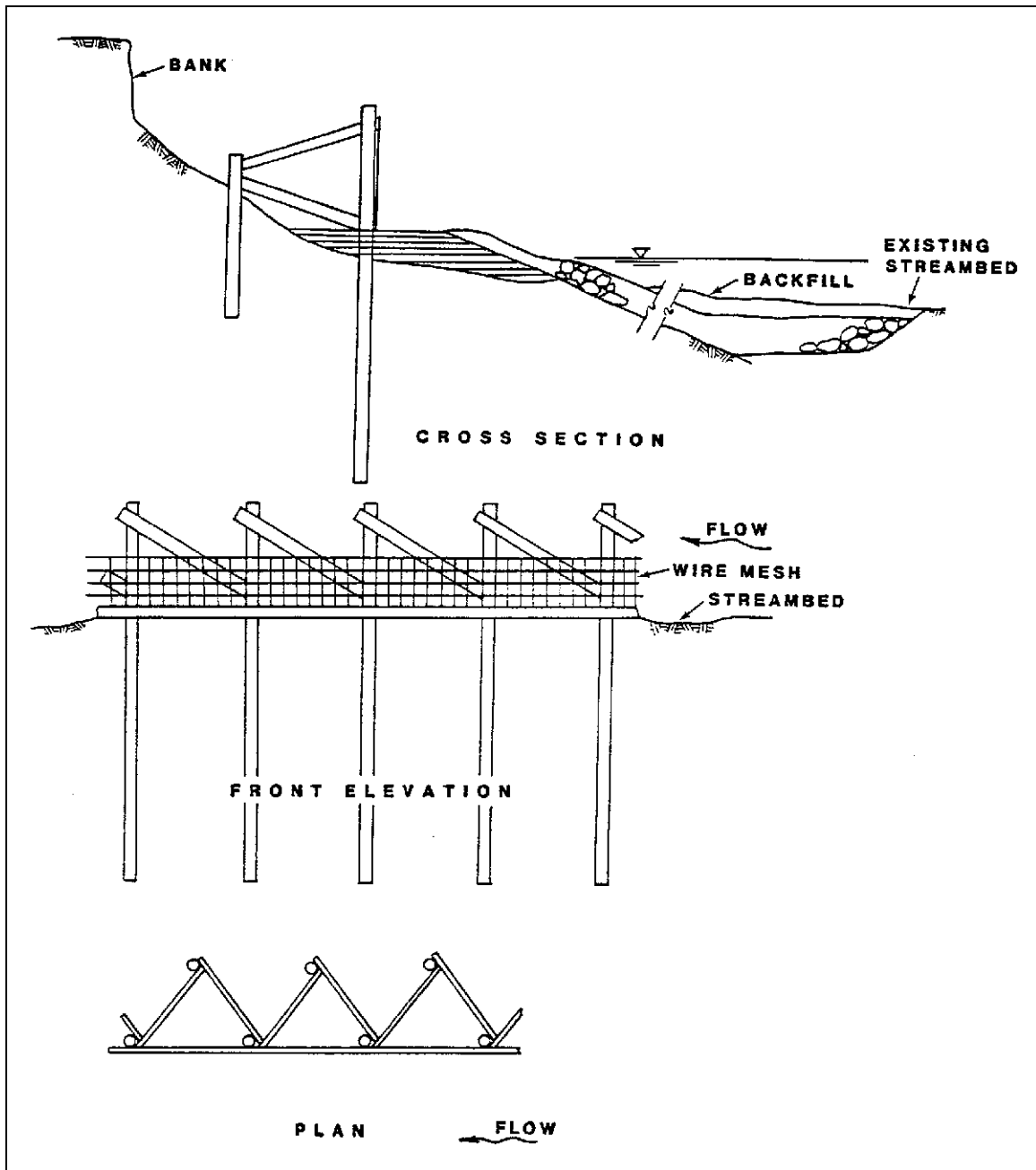

Figure 6.8. Heavy timber-pile and wire fence retarder structures (Modified from USACE, after Brown).^(2,6)

6.4.1 Earth or Rock Embankments

As the name implies, these dikes are constructed of earth with rock revetment or of rock. They are usually as high or higher than the original bank. Because of their size and cost, they are useful only for large-scale channel realignment projects.

6.4.2 Rock Toe-Dikes

Rock toe-dikes are low structures of rock riprap placed along the toe of a channel bank. They are useful where erosion of the toe of the channel bank is the primary cause of the loss of bank material. The USACE has found that longitudinal stone dikes provide the most successful bank stabilization measure studied for channels which are actively degrading and for those having very dynamic beds. Where protection of higher portions of the channel bank is necessary, rock toe-dikes have been used in combination with other measures such as vegetative cover and retarder structures.

Figure 6.9 shows the typical placement and sections of rock toe-dikes. The volume of material required is 1.5 to 2 times the volume of material that would be required to armor the sides of the anticipated scour to a thickness of 1.5 times the diameter of the largest stone specified. Rock sizes should be similar to those specified for riprap revetments (see Design Guideline 12). Tiebacks are often used with rock toe-dikes to prevent flanking, as illustrated in Figure 6.10. Tiebacks should be used if the toe-dike is not constructed at the toe of the channel bank.

Rock toe-dikes are useful on channels where it is necessary to maintain as wide a conveyance channel as possible. Where this is not important, spurs could be more economical since scour is a problem only at the end projected into the channel. However, spurs may not be a viable alternative in actively degrading streams (Design Guideline 9).

6.4.3 Crib Dikes

Longitudinal crib dikes consist of a linear crib structure filled with rock, straw, brush, automobile tires or other materials. They are usually used to protect low banks or the lower portions of high banks. At sharp bends, high banks would need additional protection against erosion and outflanking of the crib dike. Tiebacks can be used to counter outflanking.

Crib dikes are susceptible to undermining, causing loss of material inside the crib, thereby reducing the effectiveness of the dike in retarding flow. Figure 6.11 illustrates a crib dike with tiebacks and a rock toe on the stream side to prevent undermining.

6.4.4 Bulkheads

Bulkheads are used for purposes of supporting the channel bank and protecting it from erosion. They are generally used as protection for the lower bank and toe, often in combination with other countermeasures that provide protection for higher portions of the bank. Bulkheads are most frequently used at bridge abutments as protection against slumping and undermining at locations where there is insufficient space for the use of other types of bank stabilization measures, and where saturated fill slopes or channel banks cannot otherwise be stabilized.

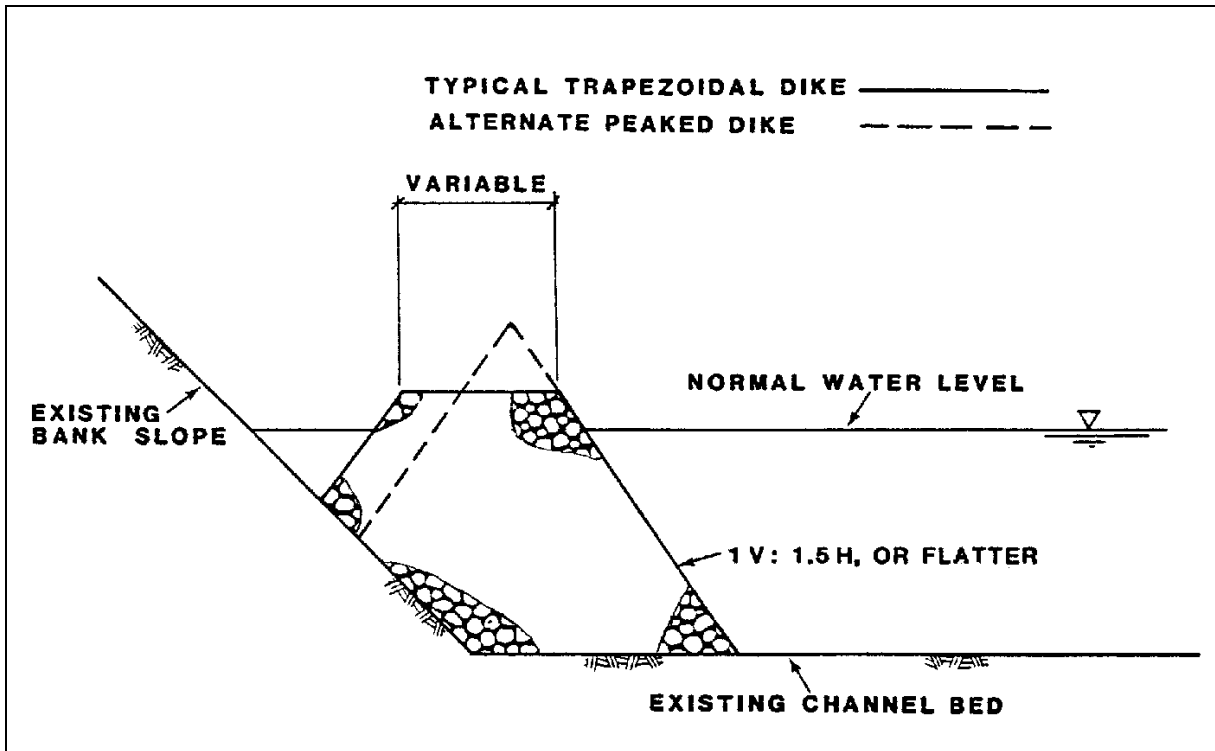

Figure 6.9. Typical longitudinal rock toe-dike geometries (after Brown).⁽²⁾

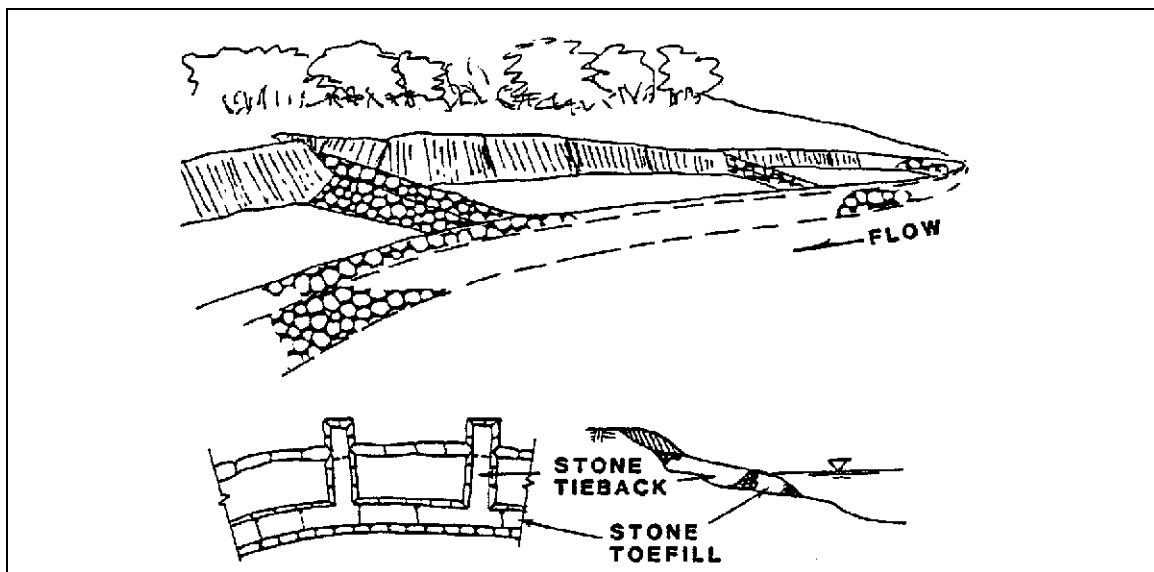

Figure 6.10. Longitudinal rock toe-dike tiebacks (after Brown).⁽²⁾

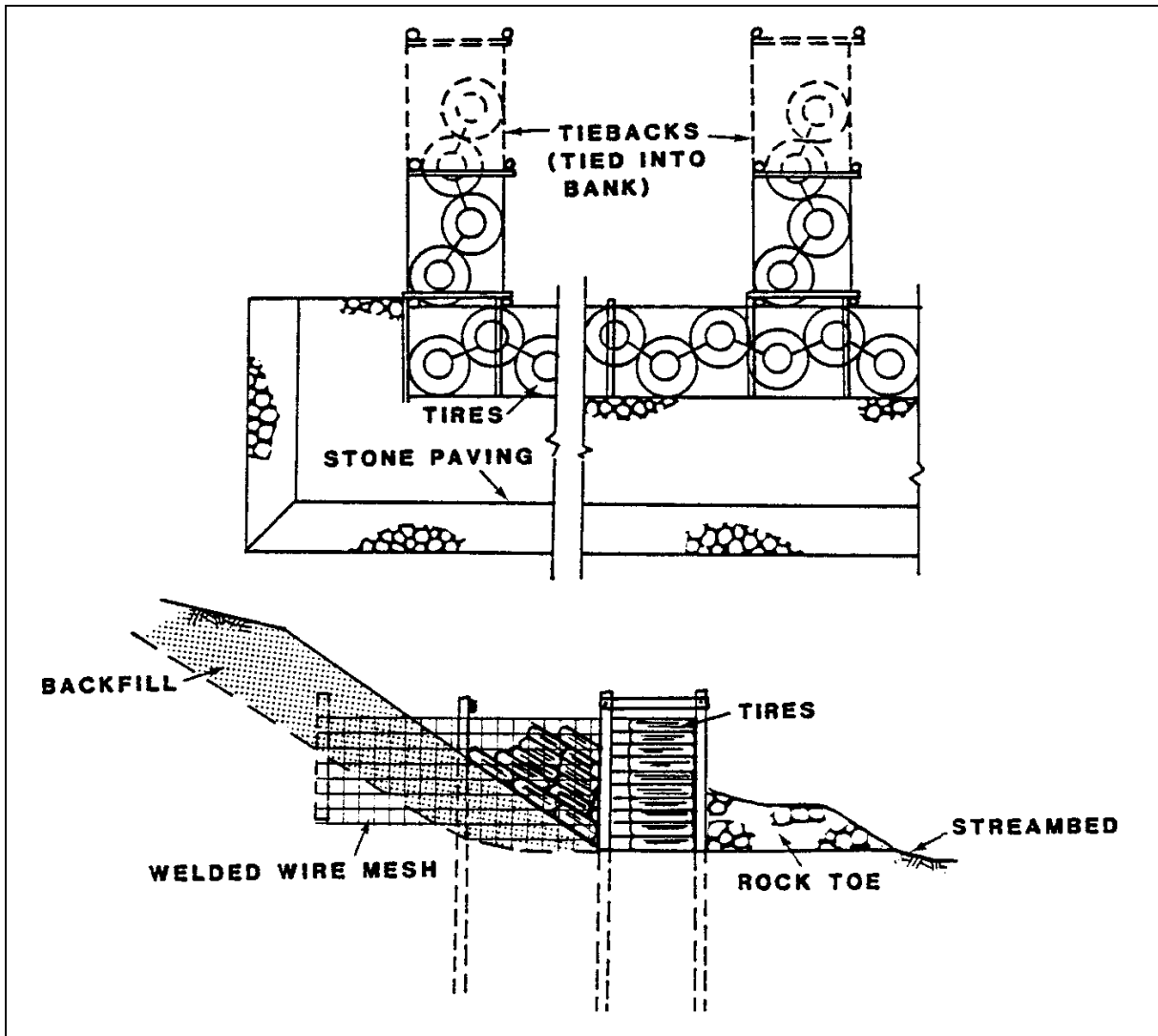

Figure 6.11. Timber pile, wire mesh crib dike with tiebacks (modified from USACE, after Brown).^(2,6)

Bulkheads are classified on the basis of construction methods and materials. They may be constructed of concrete, masonry, cribs, sheet metal, piling, reinforced earth, used tires, gabions, or other materials. They must be protected against scour or supported at elevations below anticipated total scour, and where sections of the installation are intermittently above water, provisions must be made for seepage through the wall. Some bulkhead types, such as crib walls and gabions, should be provided with safeguards against leaching of materials from behind the wall.

Bulkheads must be designed to resist the forces of overturning, bending and sliding, either by their mass or by structural design. Figure 6.12 illustrates anchorage schemes for a sheetpile bulkhead. Because of costs, they should be used as countermeasures against meander migration only where space is not available to construct other types of measures.

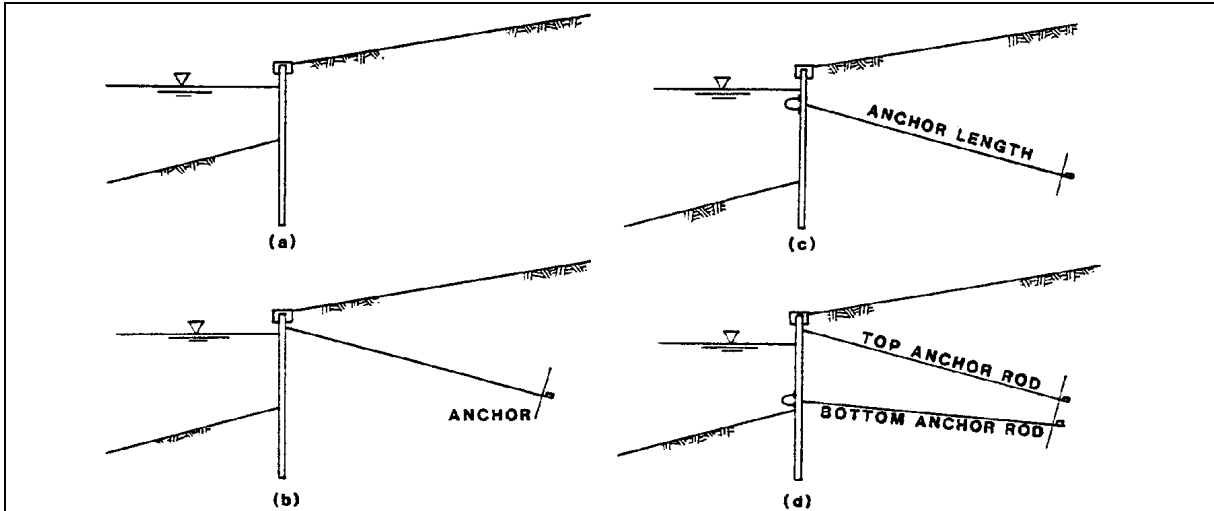

Figure 6.12. Anchorage schemes for a sheetpile bulkhead (after Brown).⁽²⁾

6.5 CHANNEL RELOCATION

At some locations, it may be advantageous to realign a stream channel, either in combination with the use of other countermeasures against meander migration or in lieu of other countermeasures.

Figure 6.13 illustrates hypothetical highway locations fixed by considerations other than stream stability. To create better flow alignment with the bridge, consideration could be given to channel realignment as shown in this figure (parts a and b). Similarly, consideration for realignment of the channel would also be advisable for a hypothetical lateral encroachment of a highway as depicted in part c of the figure. In either case, criteria are needed to establish the cross-sectional dimensions.

Before realigning a stream channel, the stability of the existing channel must be examined. The stream classification, recent and older aerial photographs, and field surveys are necessary. The realigned channel may be made straight without curves, or may include one or more curves. If curves are included, decisions regarding the radius of curvature, the number of bends, the limits of realignment (hence the length and slope of the channel) and the cross-sectional area have to be made. Different streams have different historical backgrounds and characteristics with regard to bend migration, discharge, stage, geometry, and sediment transport, and an understanding and appreciation of river hydraulics and morphology is important to decision making. It is difficult to state generalized criteria for channel relocation applicable to all streams. HEC-20⁽²³⁾ provides quantitative techniques for evaluating and predicting lateral channel migration and analyzing vertical channel stability (Chapter 6), as well as an introduction to channel restoration concepts that should be considered for channel relocation projects (Chapter 7).

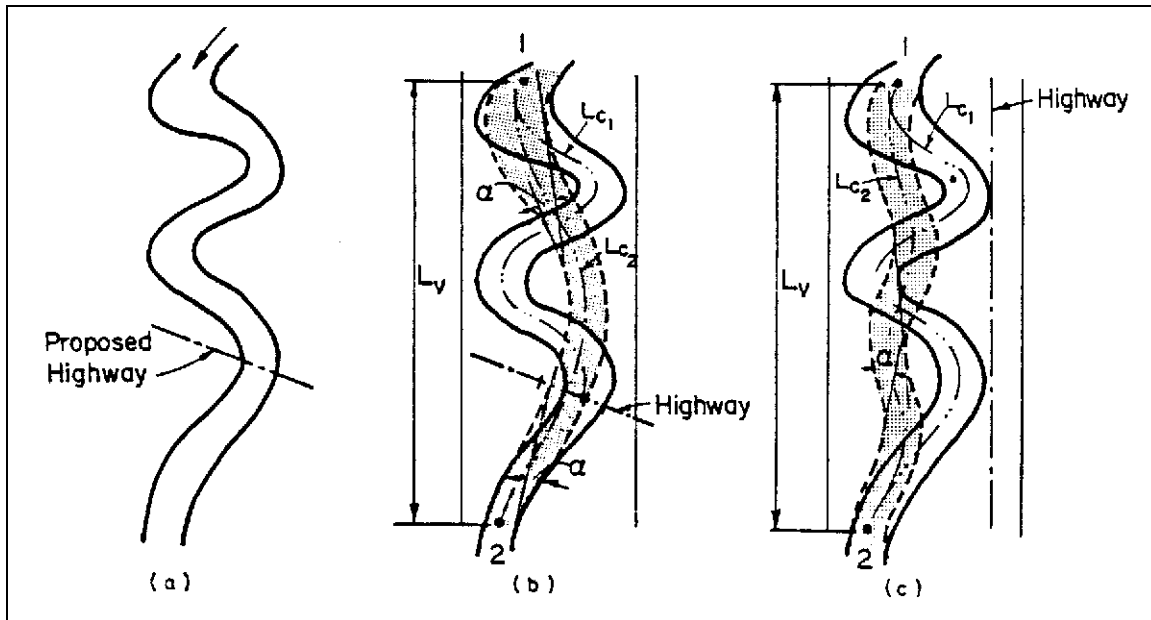

Figure 6.13. Encroachments on meandering streams (after HDS 6).⁽⁴⁾

Based on a study of the stability of relocated channels, Brice presented the following recommendations and conclusions regarding specific aspects of planning and construction of channel realignment.⁽⁵⁵⁾

- Channel Stability Prior to Realignment.

Assessment of the stability of a channel prior to realignment is needed to assess the risk of instability. An unstable channel is likely to respond unfavorably. Bank stability is assessed by field study and by stereoscopic examination of aerial photographs (see HEC-20⁽²³⁾, Section 6.2.2). The most useful indicators of bank instability are cut or slumped banks, fallen trees along the bank line, and exposed wide point bars. Bank recession rates are measured by comparison of time-sequential aerial photographs. Vertical instability is equally important but more difficult to determine. It is indicated by changes in channel elevation at bridges and gaging stations. Serious degradation is usually accompanied by generally cut or slumped banks along a channel and by increased debris transport.

- Erosional Resistance of Channel Boundary Materials.

The stability of a channel, whether natural or relocated, is partly determined by the erosional resistance of materials that form the wetted perimeter of the channel (see HEC-20⁽²³⁾, Appendix B). Resistant bedrock outcrops in the channel bottom or that lie at shallow depths will provide protection against degradation, but not all bedrock is resistant. Erosion of shale, or of other sedimentary rock types interbedded with shale, has been observed. Degradation is not a problem at most sites where bed sediment is of cobble and boulder size. However, degradation may result from the relocation of any alluvial channel, whatever the size of bed material, but the incidence of serious degradation of channels relocated by highway agencies is small in number. The erosional resistance of channel beds tends to increase with clay content. Banks of weakly cohesive sand or silt are clearly subject to rapid erosion, unless protected with

vegetation. No consistent relation has been found between channel stability and the cohesion of bank materials, probably because of the effects of vegetation.

- Length of Realignment.

The length of realignment contributes significantly to channel instability at sites where its value exceeds 250 channel widths. When the value is below 100 channel widths, the effects of length of relocation are dominated by other factors. The probability of local bank erosion at some point along a channel increases with the length of the channel. The importance of vegetation, both in appearance and in erosion control, would seem to justify a serious and possibly sustained effort to establish it as soon as possible on graded banks.

- Bank Revetment.

Revetment makes a critical contribution to stability of relocated stream channels at many sites. Rock riprap is by far the most commonly used and effective revetment (see Design Guideline 12). Concrete slope paving is prone to failure. Articulated concrete block is effective where vegetation can establish in the interstices between blocks (Design Guideline 4).

- Check Dams (drop structures).

In general, check dams are effective in preventing channel degradation in relocated channels. The potential for erosion at a check dam depends on its design and construction, its height and the use of revetment on adjoining banks. A series of low check dams, less than about 0.5 m (1.5 ft) in height, is probably preferable to a single higher structure, because of increased safety and reduced potential for erosion and failure. By simulating rapids, low check dams may add visual interest to the flow in a channel. One critical problem arising with check dams relates to improper design for large flows. Higher flows have worked around the ends of many installations to produce failure (see Design Guideline 11).

- Maintenance.

Problems which could be resolved by routine maintenance were observed along relocated channels. These were problems with the growth of annual vegetation, reduction of channel conveyance by overhanging trees, local bank cutting, and bank slumping. The expense of routine maintenance or inspection of relocated channels beyond the highway right-of-way may be prohibitive; however, most of the serious problems could be detected by periodic inspection, perhaps by aerial photography, during the first five to ten years after construction. Hydraulic engineers responsible for the design of relocated stream channels should monitor their performance to gain experience and expertise.

6.6 CASE HISTORIES OF COUNTERMEASURE PERFORMANCE

Case histories of hydraulic problems at bridge sites can provide information on the relative success of the various countermeasures used to stabilize streams. The following case histories are taken from Brice and Blodgett,⁽¹²⁾ Brice,⁽⁵⁶⁾ and Brown et al.⁽⁵⁷⁾ Site data are from Brice and Blodgett.⁽¹²⁾ This compilation of case histories at 224 bridge sites is

recommended reference material for those responsible for selecting countermeasures for stream instability. Additional case histories are given in HDS 6.⁽⁴⁾

6.6.1 Flexible Revetment

Rock Riprap. Dumped rock riprap is the most widely used revetment in the United States. Its effectiveness has been well established where it is of adequate size, of suitable size gradation, and properly installed. Brice et al. documented the use of rock riprap at 110 sites (Volume 1, Table 2).⁽¹²⁾ They rated the performance at 58 sites and found satisfactory performance at 34 sites, partially satisfactory performance at 12 sites, and failure to perform satisfactorily at 12 sites. Keeley concluded that riprap used in Oklahoma performed without significant failure and provides basic and efficient bank control on the meandering streams in Oklahoma.⁽⁵⁸⁾

A review of the causes of failure at the sites studied by Brice et al. is instructive (Volume 1, Table 3).⁽¹²⁾ They found the absence of a filter blanket clearly the cause of the failure at a site subject to tides and wave action. The riprap was placed on a fill of sand and fine gravel which eroded through the interstices of the riprap.

Internal slope failure was the cause of failure of riprap at the abutment of bridges at two sites. At one site, failure was attributed to saturation of a high fill by impounded water in a reservoir. Wave action also probably contributed to the failure. The other site is difficult to include as a riprap failure because the rock was not placed as riprap revetment. Thirty-three freight car loads of rock were dumped as an emergency measure to stop erosion at a bridge abutment during high-flow releases from a reservoir. The rock was displaced, and the high streambanks and highway fill are still susceptible to slumps. At both sites, riprap failed to prevent slumps in high fills.

Inadequate rock size and size gradation was given as the cause of failure at eight sites. All of these sites are complex, and it is difficult to assign failure to one cause, but rock size was definitely a factor.

Channel degradation accounted for failure at three sites in Mississippi. Channel degradation at these sites is due to channel straightening and clearing by the SCS (NRCS) and USACE. Riprap installations on the streambanks, at bridge abutments and in the streambed have failed to stop lateral erosion. At one site, riprap placed on the banks and bed of the stream resulted in severe bed scour and bank erosion downstream of the riprap.

Failure of riprap at one site was attributed to the steep slope on which the riprap was placed. At this site, rock riprap failed to stop slumping of the steep banks downstream of a check dam in a degrading stream.

Successful rock riprap installations at bends were found at five sites. Bank erosion was controlled at these sites by rock riprap alone. Installations rated as failing were damaged at the toe and upstream end, indicating inadequate design and/or construction, and damage to an installation of rounded boulders, indicating inadequate attention to riprap specifications. Other successful rock riprap study sites were sites where bank revetment was used in conjunction with other countermeasures, such as spurs or retards. The success of these installations was attributed more to the spurs or retards, but the contribution of the bank revetment was not discounted.

Broken Concrete. Broken concrete is commonly used in emergencies and where rock is unavailable or very expensive. No specifications were found for its use. Performance was found to be more or less unsatisfactory at three sites.

Rock-and-Wire Mattress and Gabions. The distinction made between rock-and-wire mattress and gabions is in the dimensions of the devices. Rock-and-wire mattress is usually 0.3 m (1.0 ft) or less in thickness and a gabion is thicker and nearly equidimensional. The economic use of rock-and-wire mattress is favored by an arid climate, availability of stones of cobble size, and unavailability of rock for dumped rock riprap. Corrosion of wire mesh is slow in arid climates, and ephemeral streams do not subject the wire to continuous abrasion. Where large rock is not available, the use of rock-and-wire mattress may be advantageous in spite of eventual corrosion or abrasion of the wire.

Rock-and-wire mattress performance was found to be generally satisfactory although local failure of the wire mesh and spilling out of the rock was not uncommon. Mattresses are held in place against the bank by railroad rails at sites in New Mexico and Arizona where good performance was documented (see Design Guideline 3). This is known locally as "railbank protection." The steel rail supported rock-and-wire mattress stays in place better than dumped rock riprap on the unstable vertical banks found on the ephemeral streams of this area. Mattress held in place by stakes has been found to be effective in Wyoming.

The use of rock-and-wire mattress has diminished in California because of the questionable service of wire mesh, the high cost of labor for installation, and the efficiency of modern methods of excavating for dumped riprap toe protection. The Los Angeles Flood Control District, however, has had installations in-place for 15 years or more with no evidence of wire corrosion. On the other hand, Montana and Maryland reported abrasion damage of wire. These experiences illustrate that economical use of countermeasures is dependent on the availability of materials, costs, and the stream environment in which the measure is placed.

Several sites were identified where gabions were installed, but the countermeasures had been tested by floods at only one site where gabions placed on the downstream slope of a roadway overflow section performed satisfactorily.

Other Flexible Revetment. Favorable performance of precast-concrete blocks at bridges was reported in Louisiana. Vegetation is reported to grow between blocks and contribute to appearance and stability. Vegetation apparently is seldom used alone at bridges. Iowa relies on sod protection of spur dikes, but Arkansas reported failure of sod as bank protection.

6.6.2 Rigid Revetments

Failure of rigid revetment tends to be progressive; therefore, special precautions to prevent undermining at the toe and termini and failure from unstable soils or hydrostatic pressure are warranted.

Concrete Pavement. Well-designed concrete paving is satisfactory as fill slope revetment, as revetment on streams having low gradients, and in other circumstances where it is well protected against undermining at the toe and ends. The case histories include at least one location where riprap launching aprons were successful in preventing undermining at the toe from damaging the concrete pavement revetment. Weep holes for relief of hydrostatic pressure are required for many situations (see Design Guideline 12).

Documented causes of failure in the case histories are undermining at the toe (six sites), erosion at termini (five sites), eddy action at downstream end (two sites), channel degradation (two sites), high water velocities (two sites), overtopping (two sites), and hydrostatic pressure (one site). Good success is reported with concrete slope paving in Florida, Illinois, and Texas.

Sacked Concrete. No highway agency reported a general use of sacked concrete as revetment. California was reported to regard this as an expensive revetment almost never used unless satisfactory riprap was not available. Sacked concrete revetment failures were reported from undermining of the toe (two sites), erosion at termini (one site), channel degradation (two sites), and wave action (one site) (see Design Guideline 12).

Concrete-Grouted Riprap. Concrete-grouted riprap permits the use of smaller rock, a lesser thickness, and more latitude in gradation of rock than in dumped rock riprap. No failures of grouted riprap were documented in the case histories, but it is subject to the same types of failures as other rigid revetments (see Chapter 4, Section 4.4).

Concrete-Filled Fabric Mat. Concrete-filled fabric mat is a patented product (Fabriform) consisting of porous, pre-assembled nylon fabric forms which are placed on the surface to be protected and then filled with high-strength mortar by injection. Variations of Fabriform and Fabricast consist of nylon bags similarly filled. Successful installations were reported by the manufacturer of Fabriform in Iowa, and North Dakota reported successful installations (see Design Guideline 5).

Soil Cement. In areas where any type of riprap is scarce, use of in-place soil combined with cement provides a practical alternative. The resulting mixture, soil cement, has been successfully used as bank protection in many areas of the Southwest (see Design Guideline 2). Unlike other types of bank revetment, where milder side slopes are desirable, soil cement in a stairstep construction can be used on steeper slopes (i.e., typically one to one), which reduces channel excavation costs. For many applications, soil cement is generally more aesthetically pleasing than other types of revetment.

6.6.3 Bulkheads

A bulkhead is a steep or vertical wall used to support a slope and/or protect it from erosion (See Section 6.4). Bulkheads usually project above ground, although the distinction between bulkheads and cutoff walls is not always sharp. Most bulkhead applications were found at abutments. They were found to be most useful at the following locations: (1) on braided streams with erodible sandy banks, (2) where banks or abutment fill slopes have failed by slumping, and (3) where stream alignment with the bridge opening was poor, to provide a transition between streambanks and the bridge opening. It was not clear what caused failures at five sites summarized in Brice and Blodgett, but in each case, the probable cause was undermining.

6.6.4 Spurs

Spurs are permeable or impermeable structures which project from the bank into the channel. Spurs may be used to alter flow direction, induce deposition, or reduce flow velocity. A combination of these purposes is generally served. Where spurs project from embankments to decrease flow along the embankment, they are called embankment spurs.

These may project into the floodplain rather than the channel, and thus function as spurs only during overbank flow. According to a summary prepared for the Transportation Research Board, spurs may protect a streambank at less cost than riprap revetment, and by deflecting current away from the bank and causing deposition, they may more effectively protect banks from erosion than revetment.⁽⁵⁹⁾ Uses other than bank protection include the constriction of long reaches of wide, braided streams to establish a stable channel, constriction of short reaches to establish a desired flow path and to increase sediment transport capacity, and control of flow at a bend. Where used to constrict a braided stream to a narrow flow channel, the structure may be more correctly referred to as a dike or a retard in some locations (see Design Guideline 9).

Several factors enter into the performance of spurs, such as permeability, orientation, spacing, height, shape, length, construction materials, and the stream environment in which the spur is placed.

Impermeable Spurs. The case histories show good success with well-designed impermeable spurs at bends and at crossings of braided stream channels (eight sites). At one site, hardpoints barely projecting into the stream and spaced at about 30 to 45 m (100 to 150 feet) failed to stop bank erosion at a severe bend. At another site, spurs projecting 12 m (40 feet) into the channel, spaced at 30 m (100 feet), and constructed of rock with a maximum diameter of 0.5 m (1.5 feet) experienced erosion between spurs and erosion of the spurs. At a third site, spurs constructed of timber piling filled with rock were destroyed. Failure was attributed to the inability to get enough penetration in the sand-bed channel with timber piles and the unstable wide channel in which the thalweg wanders unpredictably. Spurs (or other countermeasures) are not likely to be effective over the long term in such an unstable channel unless well-designed, well-built, and deployed over a substantial reach of stream. Although no failures from ice damage were cited for impermeable spurs, North Dakota uses steel sheet pile enclosed earth fill spurs because of the potential for ice damage. At one site, such a spur sustained only minor damage from 0.75 m (2.5 feet) of ice.

Permeable Spurs. A wide variety of permeable spur designs were also shown to successfully control bank erosion by the case histories. Failures were experienced at a site which is highly unstable with rapid lateral migration, abundant debris, and extreme scour depths. Bank revetments of riprap and car bodies and debris deflectors at bridge piers, as well as bridges, have also failed at this site. At another site, steel H-pile spurs with wire mesh have partially failed on a degrading stream.

6.6.5 Retardance Structures

A retardance structure (retard) can be a permeable or impermeable linear structure in a channel, parallel with and usually at the toe of the bank. The purposes of retardance structures are to reduce flow velocity, induce deposition, or to maintain an existing flow alignment. They may be constructed of earth, rock, timber pile, sheet pile, or steel pile. Steel jacks or tetrahedrons are also used (see Section 6.3).

Most retardance structures are permeable and most have good performance records. They have proved to be useful in the following situations: (1) for alignment problems very near a bridge or roadway embankment, particularly those involving rather sharp channel bends and direct impingement of flow against a bank (ten sites), and (2) for other bank erosion problems that occur very near a bridge, particularly on streams that have a wandering thalweg or very unstable banks (seven sites).

The case histories include a site where a rock retardance structure similar to a rock toe dike was successful in protecting a bank on a highly unstable channel where spurs had failed. There were, however, deficiencies in the design and construction of the spur installation. At another site, a rock retardance structure similar to a rock toe-dike has reversed bank erosion at a bend in a degrading stream. The USACE reported that longitudinal rock toe dikes were the most effective bank stabilization measure studied for channels having very dynamic and/or actively degrading beds.⁽⁶⁾

6.6.6 Dikes

Dikes are impermeable linear structures for the control or containment of overbank flow (see Section 6.4). Most are in floodplains, but they may be within channels, as in braided streams or on alluvial fans. Dikes at study sites were used to prevent flood water from bypassing a bridge at four sites, or to confine channel width and maintain channel alignment at two sites. Performance of dikes at study sites was judged generally satisfactory.

6.6.7 Guide Banks

The major use of guide banks (formerly referred to as spur dikes) in the United States is to prevent erosion by eddy action at bridge abutments or piers where concentrated flood flow traveling along the upstream side of an approach embankment enters the main flow at the bridge (see Design Guideline 10). By establishing smooth parallel streamlines in the approaching flow, guide banks improve flow conditions in the bridge waterway. Scour, if it occurs, is near the upstream end of the guide bank away from the bridge. A guide bank differs from dikes described above in that a dike is intended to contain overbank flow while a guide bank only seeks to align overbank flow with flow through the bridge opening. An extension of the usual concept of the purpose for guide banks, but not in conflict with that concept, is the use of guide banks and highway fill to constrict braided channels to one channel. At three sites studied, guide banks only or guide banks plus revetment on the highway fill were used to constrict wide braided channels rather severely, and the installations have performed well.

Guide bank performance was found to be generally satisfactory at all study sites. Performance is theoretically affected by construction materials, shape, orientation, and length.

Most guide banks are constructed of earth with revetment to inhibit erosion of the dike. At two sites, guide banks of concrete rubble masonry performed well. Riprap revetment is most common, but concrete revetment with rock riprap toe protection, rock-and-wire mattress, gabions, and grass sod have also performed satisfactorily. Since partial failure of a guide bank during a flood usually will not endanger the bridge, wider consideration should be given to the use of vegetative cover for protection. Partial failure of any countermeasure is usually of little significance so long as the purpose of protecting the highway stream crossing is accomplished.

Guide banks of elliptical shape, straight, and straight with curved ends performed satisfactorily at study sites, although there is evidence at one site that flow does not follow the nose of the straight guide bank. Clear evidence of the effect of guide bank orientation was not found at study sites although the conclusion from a study of guide banks in Mississippi that guide banks should be oriented with valley flow for skewed crossings of

wooded floodplains was cited.⁽⁶⁰⁾ There was evidence at one site that a guide bank may be severely tested where a large flow is diverted along the roadway embankment, as at a skewed crossing or on a wide floodplain which is severely constricted by the bridge. At these locations, embankment spurs may be advisable to protect the embankment from erosion and to reduce the potential for failure of the guide bank.

Guide banks at study sites tended to be longer than recommended by Bradley at most sites, except at five sites where they ranged from 5 to 23 m (16 to 75 ft).⁽⁵⁾ All guide banks appeared to perform satisfactorily. Not enough short guide banks were included in the study to reach conclusions regarding length.

6.6.8 Check Dams

Check dams are usually used to stop degradation in the channel in order to protect the substructure foundation of bridges (see Design Guideline 11). At one site, however, a check dam was apparently used to inhibit contraction scour in a bridge waterway. The problem with vertical scour was resolved, but lateral scour became a problem and riprap revetment on the streambanks failed.⁽¹²⁾

Scour downstream of check dams was found to be a problem at two sites, especially lateral erosion of the channel banks. Riprap placed on the streambanks at the scour holes also failed, at least in part because of the steep slopes on which the riprap was placed. At the time of the study, lateral erosion threatened damage to bridge abutments and highway fills. At another site, a check dam placed at the mouth of a tributary stream failed to stop degradation in the tributary and the delivery of damaging volumes of sediment to the main stream just upstream of a bridge.

No structural failure of check dams was documented. Failures are known to have occurred, however, and the absence of documented failures in this study should not be given undue weight. Failure can occur by bank erosion around the ends of the structure resulting in outflanking; by seepage or piping under or around the structure resulting in undermining and structural or functional failure; by overturning, especially after degradation of the channel downstream of the structure; by bending of sheet pile; by erosion and abrasion of wire fabric in gabions or rock-and-wire mattress; or by any number of structural causes for failure.

6.6.9 Jack or Tetrahedron Fields

Jacks and tetrahedrons function as flow control measures by reducing the water velocity along a bank, which in turn results in an accumulation of sediment and the establishment of vegetation. Steel jacks, or Kellner jacks which consist of six mutually perpendicular arms rigidly fixed at the midpoints and strung with wire are the most commonly used (see Section 6.3). Tetrahedrons apparently are not currently used by highway agencies. Jacks are usually deployed in fields consisting of rows of jacks tied together with cables.

Four sites where steel jack fields were used are included in the case histories.⁽¹²⁾ At two sites, the jack fields performed satisfactorily. Jacks were buried in the streambed and rendered ineffective at one site, and jacks were damaged by ice at one site, but apparently continued to perform satisfactorily. From Keeley's observations of the performance of jack fields used in Oklahoma and findings of the study of countermeasures by Brice et al., the following conclusions were reached regarding performance:^(58,12)

- The probability of satisfactory performance of jack fields is greatly enhanced if the stream transports small floating debris and sediment load in sufficient quantity to form accumulations during the first few years after construction.
- Jack fields may serve to protect an existing bank line, or to alter the course of a stream if the stream course is realigned and the former channel backfilled before the jack field is installed.
- On wide shallow channels, which are commonly braided, jack fields may serve to shift the bank line channelward if jacks of large dimensions are used.

6.6.10 Special Devices for Protection of Piers

Countermeasures at piers have been used to combat abrasion of piers, to deflect debris, to reduce local scour (see Design Guidelines 4 and 8), and to restore structural integrity threatened by scour. Retrofit countermeasures installed after problems develop are common. The usual countermeasure against abrasion consists of steel armor on the upstream face of a pier in the area affected by bed load. At one site, a pointed, sloping nose on a massive pier, called a special "cutwater" design, and a concrete fender debris deflector has functioned to prevent debris accumulation at the pier. At another site, a steel rail debris deflector worked until channel degradation caused all countermeasures to fail.

Countermeasures for local scour at piers are discussed in Chapter 3, except for a measure installed on a bridge over an estuary in Florida where about 11.3 m (37 ft) of scour had occurred. This measure consists of flat plates installed around piers to deflect plunging currents. The plates are 2.4 m (8 ft) in diameter and are installed around 510 mm (20 in.) diameter piles. It was recommended that the plates be installed at or slightly below the elevation of the streambed, but strong tidal currents prevented underwater installation at uniform locations. Two years after installation, some deposition had occurred but performance could not be judged.

Countermeasures used to restore structural integrity of bridge foundations included in the case histories include underpinning, sheet pile driven around the pier, and a grout curtain around the pier foundation.

6.6.11 Willow/Board Mattress

On large rivers such as the Mississippi and the Atchafalaya, willow/board mattresses weighted with riprap have been used for protection against scour during construction (see discussion of facine sinker mats, Chapter 4, Section 4.5). This procedure has been used for many years with success. The mattresses are usually placed at the time of construction to provide for scour protection of the caissons used to build the bridge during the construction phase and are left in place for added protection of the piers. To date, there is no information on their use on bridges where scour has been detected after construction.

6.6.12 Channel Alterations

Although channel alterations or modifications have been curtailed due to environmental concerns, their judicious use can be a viable countermeasure not to be dismissed. It is recognized that extensive channelization projects, usually made to reduce flood-plain

damage, have resulted in serious channel degradation and lateral erosion. However, there is little documentation of upstream or downstream environmental damage of an alteration of a short reach in the vicinity of a bridge.⁽¹²⁾

In a United State Geological Survey study for FHWA of 103 stream channels that were altered for purpose of bridge construction mostly during the period of 1960-1970, the stability of the relocated channel was rated as good at 36 sites, as fair to good at 42 sites, as fair at 15 sites, and as poor at 7 sites. In comparison with bank stability of the channels where such data was available before and after relocation, bank stability was about the same at 45 sites, better at 28 sites, and worse at 14 sites. At sites where the value of channel relocation length to channel width was below 100, the effects of length of channel relocation were dominated by other factors⁽⁵⁵⁾ (see Section 6.5).

6.6.13 Modification of Bridge Length and Relief Structures

A countermeasure for contraction scour and lateral movement of stream banks that may not always be considered for an existing bridge but may be needed is to increase its length. Increase bridge length was used at 11 sites and increased freeboard was provided at 2 sites. Other techniques that have been used by State Highway Agencies include the design of abutments as piers so that the bridge may be extended to accommodate future movement of the stream. Other means of providing additional relief to flow would be the use of a relief bridge.

6.6.14 Investment in Countermeasures

While it may be possible to predict that bank erosion will occur at or near a given location in an alluvial stream, one can frequently be in error about the location or magnitude of potential erosion. At some locations, unexpected lateral erosion occurs because of a large flood, a shifting thalweg, or from other actions of the stream or activities of man. Therefore, where the investment in a highway crossing is not in imminent danger of being lost, it is often prudent to delay the installation of countermeasures until the magnitude and location of the problem becomes obvious. In many, if not most, of the case histories collected by Brice et al., highway agencies invested in countermeasures after a problem developed rather than in anticipation of a problem.^(12,56)

(page intentionally left blank)

CHAPTER 7

SCOUR MONITORING AND INSTRUMENTATION

7.1 INTRODUCTION

There are many scour critical bridges on spread footings or shallow piles in the United States and a large number of bridges with unknown foundation conditions.⁽⁶¹⁾ With limited funds available, these bridges cannot all be replaced or repaired. Therefore, they must be monitored and inspected following high flows. During a flood, scour is generally not visible and during the falling stage of a flood, scour holes generally fill in. Visual monitoring during a flood and inspection after a flood cannot fully determine that a bridge is safe. Instruments to measure or monitor maximum scour would resolve this uncertainty. As introduced in Chapter 2 (Section 2.2), monitoring as a countermeasure for a scour critical bridge involves two basic categories of instruments: portable instruments and fixed instruments.

Whether to use fixed or portable instruments in a scour monitoring program depends on many different factors. Unfortunately, there is not one type of instrument that works in every situation encountered in the field. Each instrument has advantages and limitations that influence when and where they should be used. The idea of a toolbox, with various instruments that can be used under specific conditions, best illustrates the strategy to use when trying to select instrumentation for a scour monitoring program. Specific factors to consider include the frequency of data collection desired, the physical conditions at the bridge and stream channel, and traffic safety issues.

Fixed instrumentation is used when frequent measurements or regular, ongoing monitoring (e.g., weekly, daily, or continuous) are required. Portable instruments would be preferred when only occasional measurements are required, such as after a major flood, or when many different bridges must be monitored on a relatively infrequent basis. The physical conditions at the bridge, such as height off the water and type of superstructure, can influence the decision to use fixed or portable equipment. For example, bridges that are very high off the water, or that have large deck overhang or projecting geometries, would complicate portable measurements from the bridge deck. Making portable measurements from a boat assumes that a boat ramp is located near the bridge, and/or there are not issues with limited clearance under the bridge that would prohibit safe passage of a boat. Bridges with large spread footings or pile caps, or those in very deep water can complicate the installation of some types of fixed instruments. Stream channel characteristics include sediment and debris loading, air entrainment, ice accumulation, or high velocity flow, all of which can adversely influence various measurement sensors used in fixed or portable instruments. Traffic safety issues include the need for traffic control or lane closures when either installing or servicing fixed instruments, or attempting to make a portable measurement from the bridge deck.

Therefore, it is apparent that the selection of the instrument category (fixed or portable) and the specific instrument types to be used in a monitoring plan is not always straightforward. In some situations there is no clearly definable plan that will be successful, and the monitoring plan is developed knowing that the equipment may not always work as well as might be desired. Ultimately, the selection of any type of instrumentation must be based on a clear understanding of its advantages and limitations, and in consideration of the conditions that exist at the bridge and in the channel.

To improve the state-of-practice when adopting fixed instrumentation as a countermeasure, the Transportation Research Board (TRB) under the National Cooperative Highway Research Program (NCHRP) initiated NCHRP Project 21-3 "Instrumentation for Measuring Scour at Bridge Piers and Abutments" in 1989.^(62,63,64) In addition, to facilitate the technology transfer of instrumentation-related research to the highway industry, particularly those in inspection and maintenance operations, the Federal Highway Administration (FHWA) developed a Demonstration Project (DP97) on scour monitoring and instrumentation. The purpose of Demonstration Project 97 was to promote the use of new and innovative equipment, both fixed and portable, to measure scour, monitor changes in scour over time, detect the extent of past scour, and serve as countermeasures.^(13,65) This chapter provides information on the use of portable and fixed instrumentation for scour monitoring. The fixed instrument discussion includes results from NCHRP Project 21-3 and highlights fixed instrument installations conducted by FHWA under DP97. Information on implementation and experience of several State Highway Agencies with scour monitoring instrumentation is also summarized.

7.2 PORTABLE INSTRUMENTATION

7.2.1 Components of a Portable Instrument System

Portable instrumentation is typically used when a fixed instrument has not been installed at a bridge; however, portable instruments are also useful when it is necessary to supplement fixed instrument data at other locations along the bridge. Physical probing has been used for many years as the primary method for portable scour monitoring by many DOTs. More recently, sonar has seen increased use, in part due to the technology transfer provided through FHWA's Demonstration Project 97.⁽¹³⁾ The use of these methods during low-flow conditions has been very successful, for example during the 2-year inspection cycle; however, their success during flood conditions, when the worst scour often occurs, has been more limited. When appropriate, portable instrumentation is an important part of a scour monitoring program.

A portable scour measuring system typically includes four components:⁽⁶⁶⁾

1. Instrument for making the measurement
2. System for deploying the instrument(s)
3. Method to identify and record the horizontal position of the measurement
4. Data-storage device

7.2.2 Instrument for Making the Measurement

A wide variety of instruments have been used for making portable scour measurements. In general, the methods for making a portable scour measurement can be classified as:

1. Physical probing
2. Sonar
3. Geophysical

Physical Probes. Physical probes refer to any type of device that extends the reach of the inspector, the most common being sounding poles and sounding weights. Sounding poles

are long poles used to probe the bottom (Figure 7.1). Sounding weights, sometimes referred to as lead lines, are typically a torpedo shaped weight suspended by a measurement cable (Figure 7.2). This category of device can be used from the bridge or from a boat. An engineer diver with a probe bar is another example of physical probing. Physical probes only collect discrete data (not a continuous profile), and can be limited by large depth and velocity (e.g., during flood flow condition) or debris and/or ice accumulation. Advantages of physical probing include not being affected by air entrainment or high sediment loads, and it can be effective in fast, shallow water.

Sonar. Sonar instruments (also called echo sounders, fathometers or acoustic depth sounders) measure the elapsed time that an acoustic pulse takes to travel from a generating transducer to the channel bottom and back.⁽¹³⁾ Sonar is an acronym for SOund NAVigation and Ranging that was developed largely during World War II. However, early sonar systems were used during World War I to find both submarines and icebergs and called ASDICs (named for the Antisubmarine Detection Investigation Committee). As technology has improved in recent years better methods of transmitting and receiving sonar and processing the signal have developed, including the use of digital signal processing (DSP). The issues of transducer frequency (typically around 200 kHz) and beamwidth are important considerations in the use of sonar for scour monitoring work. Additionally, sonar can be adversely impacted by high sediment or air entrainment.

Applications of single beam sonar range from fish finders to precision survey-grade hydrographic survey fathometers. Low-cost fish-finder type sonar instruments have been widely used for bridge scour investigations (Figure 7.3) with a tethered float to deploy the transducer. Float platforms have included kneeboards (Figure 7.4) and pontoon-style floats (Figure 7.5).

Other types of sonar, such as side scan, multi-beam and scanning sonar, are specialized applications of basic sonar theory. These devices are commonly used for oceanographic and hydrographic survey work, but have not been widely utilized for portable scour monitoring. Side scan sonar transmits a specially shaped acoustic beam to either side of the support craft. These applications often deploy the transducer in a towfish, normally positioned behind and below the surface vessel.

While side scan sonar is one of the most accurate systems for imaging large areas of channel bottom, most side scan systems do not provide depth information. Multi-beam systems provide a fan-shaped coverage similar to side scan, but output depths rather than images. Additionally, multi-beam systems are typically attached to the surface vessel, rather than being towed. Scanning sonar works by rotation of the transducer assembly or sonar "head," emitting a beam while the head moves in an arc. Since the scanning is accomplished by moving the transducer, rather than towing, it can be used from a fixed, stationary position. Scanning sonar is often used as a forward looking sonar for navigation, collision avoidance and target delineation.

The Sonar Scour Vision system was developed by American Inland Divers, Inc (AIDI) using a rotating, and sweeping 675 Khz high resolution sonar.⁽⁶⁷⁾ The transducer is mounted in a relatively large hydrodynamic submersible, or fish, that creates a downward force adequate to submerge the transducer in velocities exceeding 6 m/s (20 ft/s) (Figure 7.6). Given the forces created, the fish must be suspended from a crane or boom truck on the bridge. From a single point of survey, the system can survey up to 100 m (328 ft) radially. Data collected along the face of the bridge can be merged into a real-time 3-dimensional image with a range of 90 m (295 ft) both upstream and downstream of the bridge.



Figure 7.1 Sounding pole measurement.



Figure 7.2. Lead-line sounding weight.



Figure 7.3. Portable sonar in use.



Figure 7.4. Kneeboard float.



Figure 7.5. Pontoon float.



Figure 7.6. AIDI system.

Geophysical. Surface geophysical instruments are based on wave propagation and reflection measurements. A signal transmitted into the water is reflected back by interfaces between materials with different physical properties. A primary difference between sonar and geophysical techniques is that geophysical methods provide subbottom, while sonar can only "see" the water-soil interface and is not able to penetrate the sediment layer. The main difference between different geophysical techniques are the types of signals transmitted and the physical property changes that cause reflections. A seismic instrument uses acoustic signals, similar to sonar, but at a lower frequency (typically 2-16 kHz). Like sonar, seismic signals can be scattered by air bubbles and high sediment concentrations. A ground penetrating radar (GPR) instrument uses electromagnetic signals (typically 60-300 mHz), and reflections are caused by interfaces between materials with different electrical properties. In general, GPR will penetrate resistive materials and not conductive materials. Therefore, it does not work well in dense, moist clays, or saltwater conditions.

The best application of geophysical technology in scour monitoring may be as a forensic evaluation tool, used after the flood during lower flow conditions to locate scour holes and areas of infilling (Figure 7.7). In general, the cost and complexity of the equipment and interpretation of the data are limiting factors for widespread use and application as a portable scour monitoring device. These issues have moderated as newer, lower cost GPR devices with computerized data processing capabilities have been developed. However, GPR may still be limited by cost and complexity, and often the need for bore hole data and accurate bridge plan information to properly calibrate and interpret the results.



Figure 7.7. Geophysical instrument in use.

7.2.3 System for Deploying the Instrument

The system for deploying the scour instrument is a critical component in a successful portable scour measurement system. In practical application, particularly under flood flow conditions, the inability to properly position the instrument is often the limiting factor in making a good measurement. The use of different measurement technologies from different deployment platforms can produce a wide variety of alternative measurement approaches.

Deployment methods for portable instruments can be divided into two primary categories

1. From the bridge deck
2. From the water surface

Bridge Deck Deployment. Bridge deck deployment can be defined by two categories, non-floating and floating. Non-floating systems generally involved standard stream gaging equipment and procedures, including the use of various equipment cranes and sounding weights for positioning a sensor in the water. This category could also include devices that use a probe or arm with the scour measurement device attached to the end. Probes or arms include things as simple as an extendable pole or rod (such as a painter's pole), to a remotely controlled articulated arm. Hand held probes or arms are not generally useable at flood flow conditions.

A prototype articulated arm to position a sonar transducer was developed under an FHWA research project.⁽⁶⁸⁾ An onboard computer calculated the position of the transducer based on the angle of the boom and the distance between the boom pivot and transducer.

Additionally, the system could calculate the position of the boom pivot relative to a known position on the bridge deck. The system was mounted on a trailer for transport and could be used on bridge decks from 5-15 m (16-50 ft) above the water surface (Figure 7.8). Field testing during the 1994 floods in Georgia indicated that a truck mounted system would provide better maneuverability, and that a submersible head or the ability to raise the boom pivot was necessary to allow data collection at bridges with low clearance (less than 5 m (16 ft)).

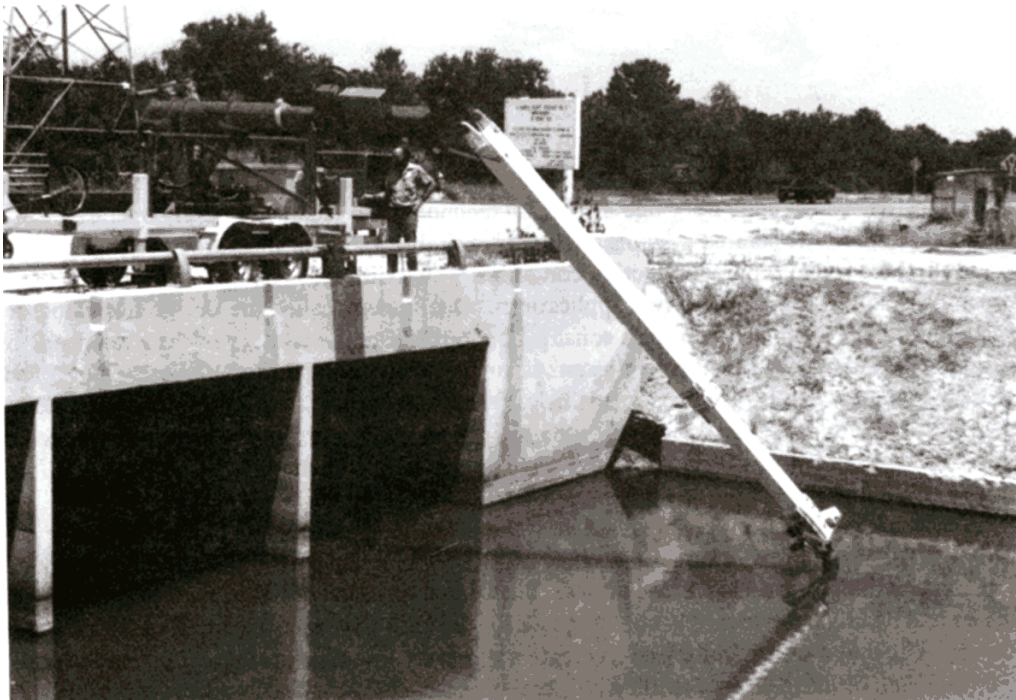

Figure 7.8. FHWA articulated arm in use.

Float based systems permit measurement beneath the bridge and along side the bridge piers. Tethered floats are a low-cost approach that have been used with some success during flood flow conditions. A variety of float designs have been proposed and used to varying degrees for scour measurements, typically to deploy a sonar transducer. Common designs include foam boards, PVC pontoon configurations, spherical floats, water skis and kneeboards.⁽¹³⁾ The size of the float is important to stability in fast moving, turbulent water.

Floating or non-floating systems can be also be deployed from a bridge inspection truck, an approach that is particularly useful when the bridge is high off the water. For example, bridges that are greater than 15 m (50 ft) off the water are typically not accessible from the bridge deck without using this approach.

Water Surface Deployment. Water surface deployment typically involves a manned boat, however, safety issues under flood conditions have suggested the use of unmanned vessels. The use of manned boats generally requires adequate clearance under the bridge and nearby launch facilities. This can be a problem at flood conditions when the river stage may approach or submerge the bridge low chord, and/or boat ramps may be underwater. Smaller boats may be easier to launch, but safety at high flow conditions may dictate use of a larger boat, further complicating these problems.

When clearance is not an issue, the current and turbulence in the bridge opening may be avoided using one of the tethered floating or nonfloating methods described above from a boat positioned upstream of the bridge. For example, a pontoon or kneeboard float with a sonar transducer could be maneuvered into position from a boat holding position upstream of the bridge, thereby avoiding the current and turbulence problems at the bridge itself.

The safety, launching and clearance issues have suggested that an unmanned or remote control boat might be a viable alternative. A prototype unmanned boat using a small flat bottom jon boat and an 8 hp outboard motor with remote controls (Figure 7.9) was successfully tested during six flood events.⁽⁶⁶⁾

7.2.4 Positioning Information

In order to evaluate the potential risk associated with a measured scour depth it is necessary to know the location of the measurement, particularly relative to the bridge foundation. Location measurements can range from approximate methods, such as 1 m (3 ft) upstream of pier 3, to precise locations based on standard land and hydrographic surveying technology.

The most significant advancement for portable scour measurement positioning may be in the use of Global Positioning Systems (GPS). GPS is a positioning system based on a constellation of satellites orbiting the earth. An advantage of GPS over traditional land-based surveying techniques is that line-of-sight between control points is not necessary. A GPS survey can be completed between control points without having to traverse or even see the other point. GPS also works at night and during inclement weather, which could be a real advantage for scour monitoring during flood conditions. The most significant disadvantage of GPS is the inability to get a measurement in locations where overhead obstructions exist, such as tree canopy or bridge decks. However, GPS measurements up to the bridge face, without venturing under the bridge, have been successful.



Figure 7.9. Unmanned, remote control boat.

7.2.5 Data Storage Devices

Portable scour monitoring data are typically manually recorded in a field book, however, there has been a growing interest in more automated data collection using various data storage devices. Available data storage devices include hydrometeorological data loggers, laptop computers and more recently palm computers and organizers. Data loggers provide a compact storage device, however, they are generally not very user friendly with each company typically having a unique programming language and approach. In field applications, laptop computers are bulky and need to be ruggedized to survive the rain, dirt and dust of a field environment. Palm computers and organizers may have an application as their capability and user-friendliness continue to improve. The advantage of laptop computers and palm computers is the ability to integrate data reduction software, such as plotting or topographic mapping programs to visual the results, often in real time mode while the data collection occurs.

7.3 FIXED INSTRUMENTATION

7.3.1 NCHRP Project 21-3

The basic objective of NCHRP Project 21-3 was to develop, test, and evaluate fixed instrumentation that would be both technically and economically feasible for use in measuring or monitoring maximum scour depth at bridge piers and abutments.⁽⁶²⁾ The scour measuring or monitoring device(s) were required to meet the following mandatory criteria.

Mandatory Criteria

- Capability for installation on or near a bridge pier or abutment
- Ability to measure maximum scour depth within an accuracy of ± 0.3 m (± 1 ft)
- Ability to obtain scour depth readings from above the water or from a remote site
- Operable during storm and flood conditions

Where possible, the devices should meet the following desirable criteria:

Desirable Criteria

- Capability to be installed on most existing bridges or during construction of new bridges
- Capability to operate in a range of flow conditions
- Capability to withstand ice and debris
- Relatively low cost
- Vandal resistant
- Operable and maintainable by highway maintenance personnel

Since the mandatory criteria required that the instruments be capable of installation on or near a bridge pier or abutment, the research was limited to fixed instruments only. While the research was conducted in phases, a final project report was prepared to integrate and summarize the findings, interpretation, conclusions and recommendations for the total research effort.⁽⁶²⁾ A separate Installation, Operation, and Fabrication Manual was developed for both the magnetic sliding collar device and low-cost sonic instrument system that resulted from this research.^(69, 70)

7.3.2 Scour Measurement

Although a vast literature exists relating to bridge scour, relatively few reports deal specifically with instrumentation. The final report for NCHRP Project 21-3 includes an extensive bibliography on equipment for scour measurement and monitoring.⁽⁶²⁾ A detailed survey of the evolution of scour measuring instrumentation was presented at the Transportation Research Board Third Bridge Engineering Conference in 1991.⁽⁷¹⁾ This section summarizes the development of scour measuring equipment and techniques that had particular relevance to the instrumentation developed under the NCHRP project.

Major advances in instrumentation such as sonar, sonic sounders, electronic positioning equipment, and radar occurred during World War II. By the mid 1950s, many devices became commercially available and were introduced into scientific studies of rivers. A dual channel sonic stream monitor was used in the 1960s to study alluvial channel bed configurations and the scour and fill associated with migrating sand waves. Commercial sonic sounders became available about the same time and soon were used extensively in hydrographic surveys.

In the 1970s, many scour studies were undertaken in New Zealand. One of the instruments used in the field to measure maximum scour depth at bridge piers was called the "Scubamouse." The device consists of a vertical pipe buried or driven into the streambed in front of the bridge pier around which is placed a horseshoe-shaped collar that initially rests on the streambed. The collar slides down the pipe and sinks to the bottom of the scour hole as scour progresses during a flood. The position of the collar is determined by sending a detector down the inside of the pipe after the flood. Earlier models involved a metal detector inside a PVC pipe, but the pipe was sometimes damaged by debris, so the current models use a steel pipe, a radioactive collar, and a radiation detector inside the pipe. This device has been installed on many bridges in New Zealand.⁽⁷²⁾

In the United Kingdom, Hydraulic Research Limited of Wallingford has developed and deployed a buried rod instrument system to monitor bed scour during flood events.⁽⁷³⁾ This 'Tell Tail' scour monitoring system is based on omni-directional motion sensors, buried in the river or sea bed adjacent to the structure. The sensors are mounted on flexible 'tails' and are connected to the water surface via protected cables. Under normal flow conditions, the detectors remain buried and do not move. When a scour hole develops, the sensors are exposed and transmit alarm signals to the surface.

In the early 1990s, there were no accepted methods or off-the-shelf equipment for collecting scour data in the United States. In part, this was because there had been no coordinated long-term effort to study scour processes. Also, most scour studies were site-specific and the equipment and techniques that were used were tailored to the geometry of the site and its hydrology and hydraulic conditions. The Brisco Monitor™, a sounding rod device, was available, but had not been tested extensively in the field.

Scour studies in the United States were carried out with a great variety of portable equipment and techniques, and, through the U.S. Geological Survey (USGS) National Scour Study, conducted in cooperation with the Federal Highway Administration (FHWA), efforts were made to standardize the collection of scour data.⁽⁷⁴⁾ Techniques for determining the extent of local scour include the use of divers and visual inspection, direct measures of scour with mechanical and electronic devices, and indirect observations using ground-penetrating radar and other geophysical techniques.⁽⁷⁵⁾

In the early 1990s, the USGS investigated the use of fixed instruments for scour measurement at a new bridge on U.S. Highway 101 across Alsea Bay near Walport, Oregon. Depth soundings were made using commercially available sonic sounders. The transducers for sounding were mounted on brackets attached to the piers and pointed out slightly to avoid interference from the side of the pier. The system worked well, but the installation was not subject to debris, ice, or air entrainment from highly turbulent flows.⁽⁷⁶⁾

In summary, an initial literature search on scour instrumentation in 1990 revealed, and a resurvey of technology in 1994 confirmed, that fixed scour-measuring and -monitoring instruments can be grouped into four broad categories:

1. Sounding rods - manual or mechanical device (rod) to probe streambed
2. Buried or driven rods - device with sensors on a vertical support, placed or driven into streambed
3. Fathometers - commercially available sonic depth finder
4. Other Buried Devices - active or inert buried sensor (e.g., buried transmitter)

As a result of the literature review a laboratory testing program was designed to test at least one device from each category and to select devices for field testing that would have the greatest potential for meeting mandatory and desirable criteria.

7.3.3 Laboratory Testing

The laboratory testing program was conducted at the Hydraulics Laboratory located at the Engineering Research Center of Colorado State University (CSU). In this section, the significant results from the laboratory testing program are summarized for each instrument tested.

Sounding Rods. The laboratory investigations indicated that the mechanical sounding rods are susceptible to bed surface penetration in sand bed channels which influences their performance and accuracy. From this, and from tests with enlarged baseplates, it was apparent that the bearing stress of the sounding rod device needs to be kept below a threshold maximum when it is installed on sand bed channels. The test data on the sounding rod class of device also indicated that these devices may be best suited for piers or abutments where the instrument can be mounted in a vertical orientation. Installing a sounding rod through a pier footing is not recommended because of a tendency of the device to jam or stick.

Low-Cost Fathometers. The survey of instrument technology revealed that there are several sophisticated, research-quality fathometers available commercially. Rather than adopt one of these relatively expensive instruments to a scour-measuring function, it was of interest to determine if, and to what extent, low-cost fathometers could be used for measuring scour. Such devices are readily available from several manufacturers.

Fathometers must be mounted so the transducer is aimed at the location where maximum scour will occur and the signal must be unobscured by debris or ice. Loss of signal associated with the entrainment of air (which was experienced in the laboratory flume) or very high sediment concentrations may not be a major concern for most applications with fathometers. However, there may be cases in the field where highly turbulent, air-entrained flow conditions or suspended sediment will preclude the use of these instruments.

Buried/Driven Rods. This class of scour measuring device includes all sensors and instruments supported by a vertical support member such as a pipe, rail or column which could be placed vertically in the bed at the location where scour would be expected to occur. Installation of the support column could be either by driving, jetting, augering, or excavation and burying. Examples of this class of device include the New Zealand "Scubamouse" and the Wallingford "Tell-Tail" devices.^(72, 73)

The objectives for laboratory testing of this type of device were to ascertain the degree to which the presence of a driven/buried rod would enhance or inhibit scour in front of piers; document how a sliding collar similar to the "Scubamouse" performs; and to develop and test other bed level sensor concepts, such as a piezoelectric polymer film which is widely used in the electronics industry.

Piezoelectric film, mercury tip switches and magnetic switches installed on the buried/driven rod performed as designed and provided an accurate indication of the progression of the scour hole. The tests showed that these devices offer a viable method for measurement of

scour at bridge piers and abutments. Furthermore, it was demonstrated that these devices can be linked to data logging equipment.

There is no evidence that buried/driven devices either enhance or reduce scour at the pier. Small scale tests of a sliding collar installed on the buried rod indicate that this type of device must be carefully designed to prevent sticking or jamming.

Other Buried Devices. This class of devices includes sensors which could be buried in the bed of a river at various elevations. When scour exposes these instruments they would be rolled or floated out of the scour hole. These sensors could be either untethered or tethered to the pier or abutment. Obtaining scour data from a tethered device could be as simple as visually inspecting which tethered devices have been removed from the hole by scour. The untethered devices would most likely incorporate a motion-activated transmitter, with a receiver on the bridge or stream bank sensing when a transmitter has been moved and activated.⁽⁷⁷⁾

Near-prototype tests of inert (no electronics) tethered and untethered buried devices indicated that these types of instruments could be developed and adapted for measuring scour at bridge piers and abutments.

7.3.4 Field Testing

The primary objectives of field testing of scour instrumentation were to test the adaptability of promising instruments to a wide range of bridge pier and abutment geometries and subject the instruments to a variety of geomorphic and environmental conditions. An additional significant objective was to gain experience in working with local state highway personnel who would ultimately be responsible for installation, maintenance, and collection of data from scour-monitoring devices.

The project included field installation of a Brisco Monitor™ sounding rod, simple and automated magnetic sliding collar devices, and low-cost bridge deck serviceable sonic instrument systems.⁽⁶²⁾ Several simple magnetic sliding collar devices were installed under a cooperative "wider deployment" program through which instruments were purchased by the Minnesota and Michigan Departments of Transportation and installations were accomplished by the DOT with the advice and assistance of the NCHRP Research Team.

Additional field experience with simple magnetic sliding collar devices and low-cost sonar instrument systems was obtained through a cooperative arrangement with the FHWA Demonstration Project (DP) 97 program. DP97 provided instruction in and demonstration of fixed and portable devices to detect, measure, and monitor bridge scour. To provide a broader experience base for instrument demonstrations, FHWA funding and NCHRP project technical assistance were provided to the Texas Department of Transportation and the USGS in New York and Oregon for installation of simple magnetic sliding collar and sonic devices (see Section 14.3). In addition, limited testing of prototype driven rod devices with piezoelectric film sensors was conducted by both the NCHRP Research Team and by the USGS in Oregon.⁽⁷⁶⁾

Field testing of the sounding rod (Brisco Monitor™) served, primarily, to confirm the results of laboratory testing of this device. As noted, only limited testing of a piezofilm driven rod device was conducted; however, that testing showed sufficient promise that further testing may be warranted.⁽⁶²⁾

The following discussion will focus on the field testing results of only the magnetic sliding collar devices and low-cost sonic instrument systems which were considered fully field deployable at the conclusion of NCHRP Project 21-3.

Magnetic Sliding Collar Devices. Both simple (manually read) and automated readout magnetic sliding collar devices were installed and tested in a variety of locations in the field. Testing included pier installations of simple sliding collar instruments at the Orchard Bridge on the South Platte River in Colorado, and the Bernado Bridge on the Rio Grande in New Mexico. Automated magnetic sliding collar devices were installed and tested on a pier of the Nassau Sound Bridge near Jacksonville, Florida and on a sloping abutment of the South Platte River Bridge near Kersey, Colorado.

Simple magnetic sliding collar devices were purchased by Minnesota and Michigan Departments of Transportation and installed at bridge piers in these states. This cooperative "wider deployment" program provided feedback from the State DOTs on instrument installation, operation, and maintenance, and expanded the range of bridge geometry and geomorphic conditions under which the instruments were tested.

Laboratory testing of a driven rod with an open architecture sliding collar with attached 152 mm (6-inch) magnets (Figure 7.10) indicated that the sliding collar accurately tracked the progression of scour. Using this concept, a field prototype of a magnetic sliding collar was designed and fabricated. This instrument consisted of a 51-mm (2-inch) diameter stainless steel support pipe in 1.5-m (5-foot) sections. A magnetic collar, similar in design to the original collar used for laboratory testing, was fabricated to slide on the support pipe; however, the externally mounted magnetic switches tested in the laboratory were replaced by a much simpler approach to measuring scour. To determine the position of the collar, a sensor (probe) consisting of a magnetic switch attached to a battery and buzzer on a long graduated cable was fabricated. In operation, the probe is lowered through the annulus of the support pipe and the buzzer activates when the sensor reaches the magnetic collar. Collar position is determined by using the graduated cable to determine the distance from an established datum near the top of the support pipe to the magnetic collar.

Following field testing of manual readout magnetic sliding collar devices at the Colorado and New Mexico test sites, it was apparent that the support pipe or extension conduit, which is normally fastened to the upstream face of a bridge pier, can be vulnerable to ice or debris impact. Development of an automated readout magnetic sliding collar device could reduce this vulnerability to debris and ice impact if only the head of the device protrudes from the streambed in front of a pier or adjacent to an abutment. A flexible conduit with the wiring for the automated readout could carry the signal by a less vulnerable route, such as along a pile cap or pier footer and up the downstream face of a pier to a datalogger (Figure 7.11).

In order to automate the operation of the magnetic sliding collar, a laboratory prototype electronic insert (probe) was developed. The insert consisted of string of magnetically actuated reed switches located at 152-mm (6-inch) intervals along the length of a stainless steel support structure. Magnets on the sliding collar actuate the reed switch at a given position as it comes in proximity. A datalogger provides excitation voltage for a brief sampling period. The probe is encased with waterproof flexible tubing, and is then inserted into the stainless steel pipe section(s) that comprise the support rod for the instrument. Sensors at different levels are activated as the magnet on the sliding collar slides down the stainless steel pipe as scour develops.

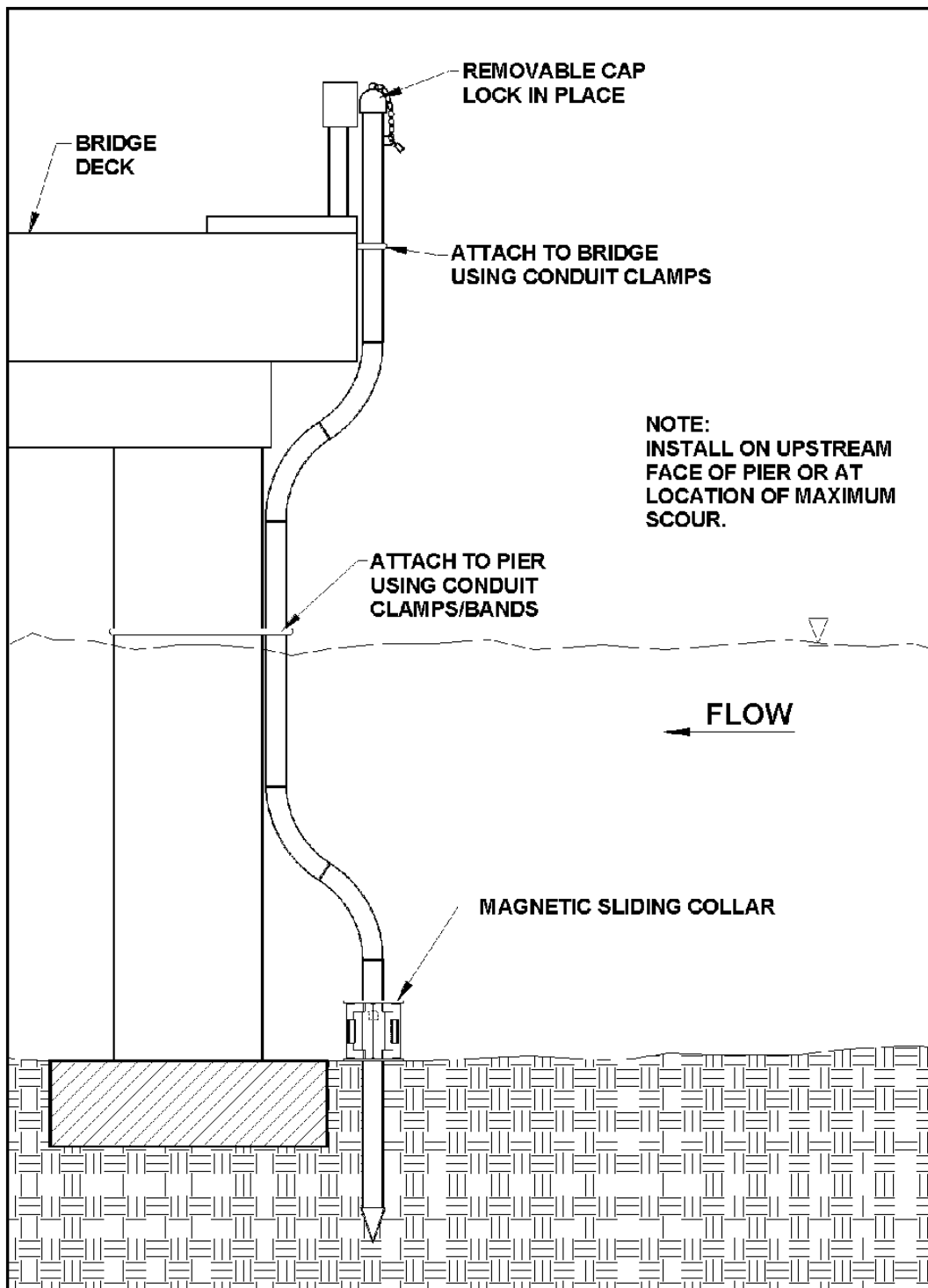

Figure 7.10. Manual read out magnetic sliding collar device.⁽⁶⁹⁾

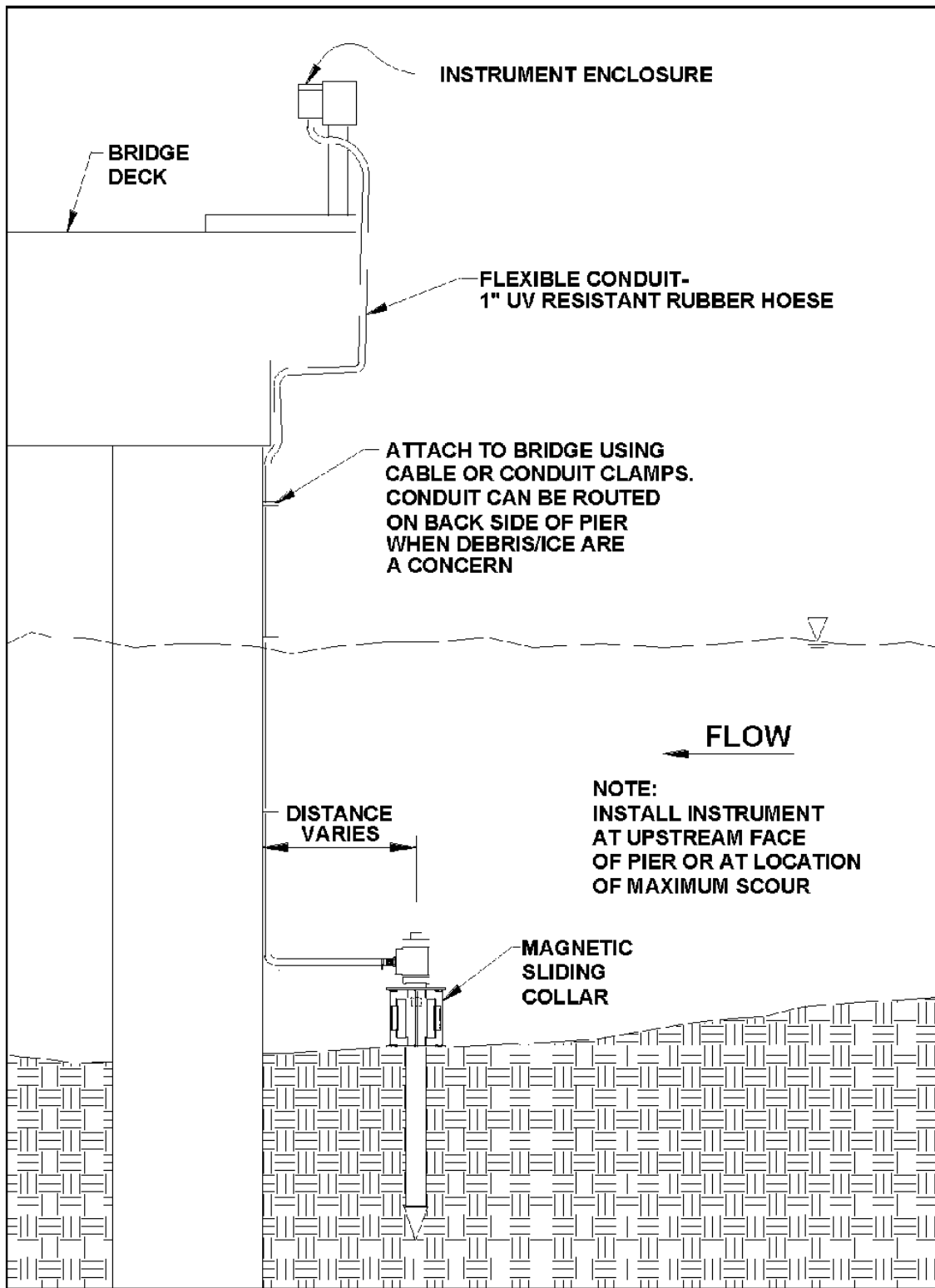

Figure 7.11. Automated read out magnetic sliding collar system.⁽⁶⁹⁾

The most significant findings from field testing of both simple (manual readout) and automated magnetic sliding collar devices include:

- A manual readout magnetic sliding collar device successfully tracked scour at the South Platte River test site (in Colorado) and met all established mandatory criteria and most desirable criteria. While this instrument system could be vulnerable to ice and debris impact, under field conditions on the South Platte River involving both ice and debris only moderate damage was experienced and the instrument remained operational for the 4-year duration of the project.
- An automated magnetic sliding collar instrument was successfully installed on a bridge over the South Platte River near Kersey, Colorado. This installation proved the performance of an automated sliding collar instrument under field test conditions and contributed to development of concepts for instrumenting a sloping abutment. The instrument was also used to demonstrate a successful cellular phone link between the field test site and a base station 64 km (40 miles) away.
- An automated magnetic sliding collar instrument was installed in a tidal environment on the Nassau Sound bridge near Jacksonville, Florida. The use of antifouling paint on the collar and a plastic sheath on the driven rod appeared to reduce the potential for impact of barnacle growth on instrument operation. While some fill, not scour, has occurred at this site, the electronic components of the instrument system, including the underwater cable link and datalogger remained functional for the duration of the project.
- Simple (manual readout) magnetic sliding collar devices were fabricated and installed in Michigan (1 site) and Minnesota (3 sites) in cooperation with the respective state DOTs. These installations clearly demonstrated that this instrument system is adaptable to a variety of field conditions and can be installed with the equipment and technical skills normally available at the District level of a DOT.
- The Michigan and Minnesota installations demonstrated the vulnerability to ice and debris impact of the simple sliding collar system. The instrument at one site in Minnesota was destroyed by impact from a large floating log. Conversely, another site remained operational even after significant debris had accumulated on the instrumented pier.

Low-Cost Fathometer Instrument Systems. Field testing of sonic depth finders (fathometers) included pier installations at the Orchard Bridge on the South Platte River in Colorado, the San Antonio Bridge on the Rio Grande in New Mexico, and the Johns Pass Bridge over a tidal inlet on Florida's Gulf Coast. A low-cost fathometer was also configured and installed on a sloping abutment at the Kersey Bridge over the south Platte River in Colorado.

Standard practice for installation of fathometers to monitor bridge scour has been to mount the sonic transducers into a small durable steel encasement which was then bolted to the pier of the bridge below water level. The NCHRP project developed an alternative which permits mounting the transducer so that it can be serviced from the bridge deck or above water. Either steel or PVC conduit is bracketed to the bridge substructure to "aim" the sonic transducer at the most likely location for scour. The transducer was encased in a PVC "probe," which was pushed down through a larger diameter steel or PVC conduit (Figure 7.12). The probe snapped into position so that it protruded through a fitting located below water at the bottom of the conduit. With this arrangement the transducer is serviceable from above water.

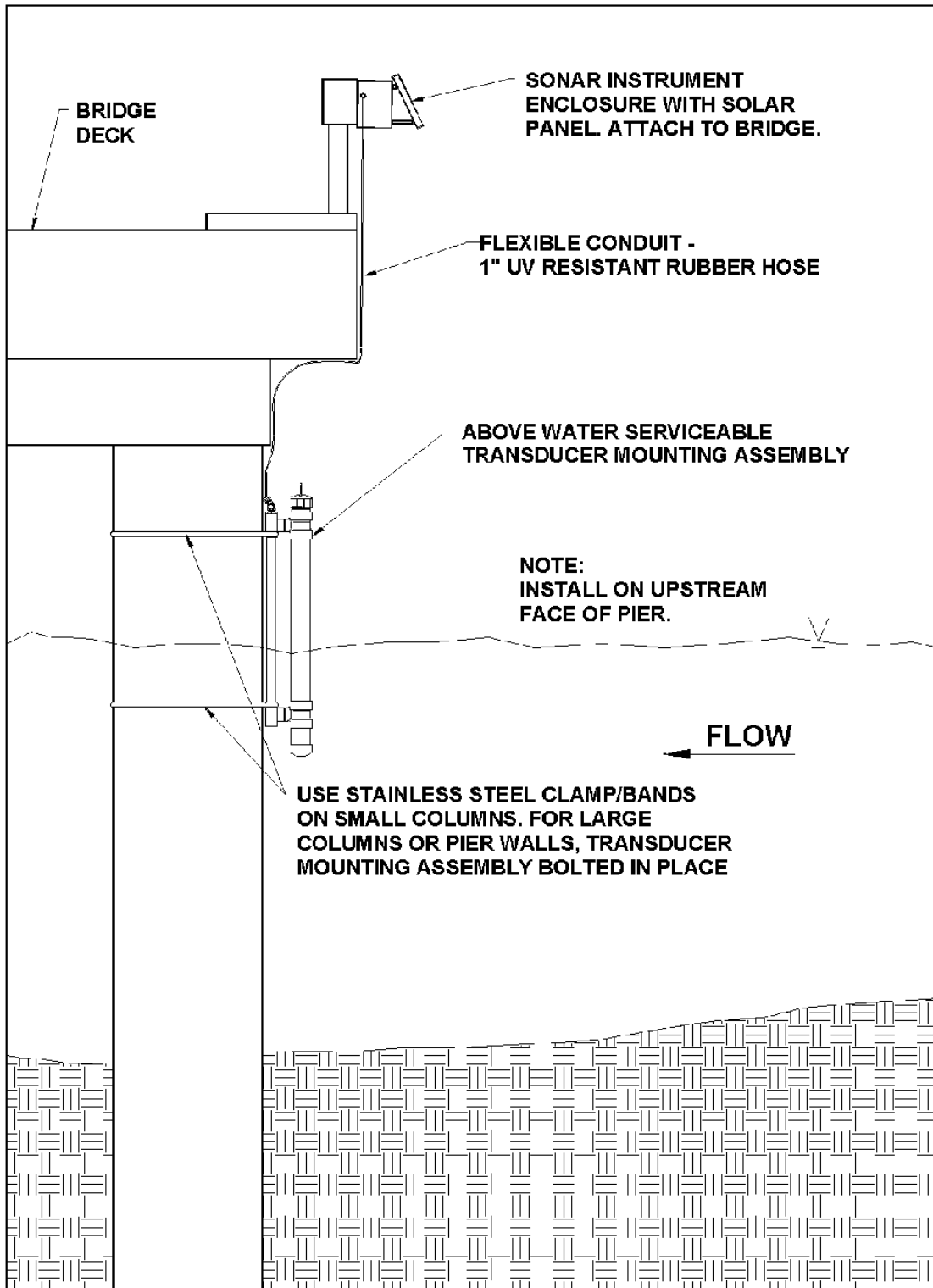

Figure 7.12. Above-water serviceable low-cost fathometer system.⁽⁷⁰⁾

The most significant findings from field testing of low-cost fathometer instrument systems include:

- A reliable low-cost sonic system was developed, consisting of a fish finder type fathometer, datalogger/interface, solar panel and battery, and a transducer which can be mounted in a bridge deck (above-water) serviceable configuration or fixed to the bridge substructure below water. This system exceeded the initial expectations for this type of instrument and met all established mandatory criteria and most desirable criteria.
- A low-cost sonic system performed well on a bridge pier on the South Platte River in Colorado under variable flow conditions, with ice and debris. A scour-and-fill episode was documented and correlated with stream-gaging data.
- A low-cost sonic system in a bridge deck serviceable configuration was installed on a pier of the San Antonio bridge over the Rio Grande in New Mexico using a mounting bracket clamp on a pile cap. Instrument installation was affected by debris accumulation around the bridge piers and, at this site, the performance of the instrument was hindered by the accumulation of debris.
- A low-cost sonic system was fabricated and installed on a tidal bridge pier on Florida's Gulf Coast. The system performed well over a 4-year period. Antifouling paint protected the transducer face for the first year of operation, but by the end of the second year barnacle growth, which had begun to interfere with system operation, had to be removed. This instrument provided an excellent continuous record of seasonal scour and fill and performed successfully under storm-surge conditions.
- A study of temperature and salinity effects on the speed of sound found that there should not be a concern for most installations, within the limits established by the mandatory criteria (± 0.3 m [± 1.0 ft] accuracy) and for the depth and temperature ranges expected at most riverine and tidal bridge sites. If necessary, the corrections for temperature and salinity can be made as a post-processing step.

7.3.5 Evaluation of Instrument Performance

A general evaluation of how devices tested meet the objectives of NCHRP Project 21-3 is presented in Table 7.1 based on the criteria specified in the Introduction. Table 7.1 includes two additional desirable criteria as follows:

- Reliability
- Operable when sub-surface or foundation conditions are not known

Table 7.1 summarizes in matrix format the results of research on the instrument systems that were the focus of NCHRP Project 21-3. The Brisco Monitor™ which was tested in the laboratory and at one field site is also included in this summary (Sounding Rod). It should be noted that the piezoelectric film device has had only limited field testing and evaluations relative to this device represent expectations rather than proven capabilities. Future research may or may not support these expectations.

Table 7.1. Comparison of Devices Tested With Mandatory and Desirable Criteria.																	
Device	Mandatory Criteria						Desirable Criteria										
	1a	1b	1c	1d	2	3a	3b	4	5	6	7a	7b	8	9	10	11	12
	Install on or near Sloping Piers or Vert. Pier	Install on or near Sloping Piers w/Footings	Install on or near Vert. Abut.	Install on Spill-thru Abut.	Measure Scour to $\pm 1'$	Read from Above Water Line	Remote Data Collection	Operable During Floods	Ease of Installation	Range of Discharges	Withstand Ice and Surface Debris Impact	Obtain Scour Data with/without Debris	Low Cost	Vandal Resistant	Operation and Maintenance	Reliability	Unknown Foundation or Sub-Surface Condition
Sounding Rod	G	F	G	P	G	G	P	G	F	G	G	F	F	F	G	P	F
Sliding Collar Manual Automated	G	G	G	P	G	G	NA	G	G	G	F	F	G	G	G	G	F
Low-Cost Sonar	G	G	G	F	G	G	G	G	G	G	G	P	G	F	G	G	G
Piezo Electric Driven Rod	G	G	G	U	G	G	G	G	U	G	G	G	U	F	U	U	F

G = Good, F = Fair, P = Poor, U = Unknown at present, NA = Not Applicable

The following notes provide a brief explanation of the reasoning for any rating less than "good."

<p>Criterion 1b</p> <ul style="list-style-type: none"> The sounding rod was rated fair because this device is not recommended categorically for piers with spread footings or sloping piers. <p>Criterion 1d</p> <ul style="list-style-type: none"> When placed on an angle on spill-through abutments, sounding rod will not measure maximum scour. A manual readout magnetic sliding collar would be difficult to use on a spill-through abutment without special mounting arrangements. A fathometer may be difficult to use on spill-through abutments without special mounting arrangements. <p>Criterion 3b</p> <ul style="list-style-type: none"> As tested, the sounding rod had serious data collection problems. The manufacturer indicates that these problems have been resolved. <p>Criterion 5</p> <ul style="list-style-type: none"> The sounding rod tested was heavy and required special equipment for installation. <p>Criterion 7a</p> <ul style="list-style-type: none"> The connecting conduit to the bridge deck for the manual-read device can be vulnerable to ice and debris impact. <p>Criterion 7b</p> <ul style="list-style-type: none"> Ice could bind the rod for sounding rod devices. Ice or debris could impact the connecting conduit of the manual readout sliding collar. Ice and debris can block the signal for fathometers. 	<p>Criterion 8</p> <ul style="list-style-type: none"> Equipment costs (not including installation) less than \$5,000 were categorized as good. <p>Criterion 9</p> <ul style="list-style-type: none"> Only those devices which can be buried and don't require a datalogger were classified as good. <p>Criterion 10</p> <ul style="list-style-type: none"> Fathometers were rated as good for above water serviceable configuration, but would be rated fair for transducers which are not serviceable above water. <p>Criterion 11</p> <ul style="list-style-type: none"> The sounding rod as tested was not considered reliable, primarily because of data logger problems. The low-cost sonic instrument itself proved to be very reliable during field testing, but for the sonic system reliability is poor on debris-prone streams. <p>Criterion 12</p> <ul style="list-style-type: none"> Information on a buried pile cap or spread footer would be required for proper operation of a sounding rod. The installation of driven rod devices is difficult where rock, buried debris, or resistant layers are encountered.
---	--

7.3.6 Application Guidelines

Bridge Pier and Abutment Geometry. It is clear that no single device is applicable to all bridge pier and abutment geometries. However, most bridge geometries can be accommodated with one of the scour measuring devices evaluated and tested during this research.

All instruments tested are adaptable in some degree to vertical piers and abutments. Sloping piers and spill-through abutments present difficulties for most instrument configurations. Driven rod instruments, such as the automated sliding collar or piezoelectric film device that are not fastened to the substructure can be used on sloping piers and abutments, however, the piezoelectric sensor driven rod has had only limited field testing. Adapting scour instrumentation to a large spread footing or pile cap configuration also presents challenges.

Flow and Geomorphic Conditions. Each class of scour measuring instrument will not be applicable to all flow and geomorphic conditions. While some limitations stem from the capabilities of the device itself, some pertain to whether the device is installable given the geomorphic and flow conditions. For example, sounding rods have not performed well in sand-bed streams, although the addition of a large baseplate to the sounding rod could help correct the problem.

All devices using a driven rod configuration will have limitations imposed by bed and substrate characteristics. Predrilling, jetting, or augering may permit installation under a wide range of conditions, but these techniques may be expensive and could be difficult over water. The connecting conduit required by the manual-readout sliding collar device is vulnerable to ice and debris impact, but the instrument proved surprisingly durable at field test sites with significant debris.

Low-cost fathometers are applicable to a wide range of streambed characteristics and flow and geomorphic conditions, but ice and debris in the stream can quickly render a fathometer inoperable. Strategies such as placing the transducer close to the streambed may reduce, but won't eliminate, the vulnerability of this instrument to ice and debris.

Instrument Costs. The "low-cost" sonic system as tested under NCHRP Project 21-3 will cost approximately \$4,000. The cost of a magnetic sliding collar device will range from \$2,500 for a simple manual-readout device to \$4,000 for an automated system. Instrument system costs include the basic instrument and mounting hardware, as well as power supply, data logger, and instrument shelter/enclosure, where applicable. A cell-phone telemetry link will add approximately \$3,000 to the system cost. A float-out buried transmitter can be fabricated for approximately \$500, and monitored by the same data logger/cell-phone system installed for either a sonic system or automated sliding collar.

The installation costs for sliding collar and sonic devices can vary dramatically depending on the complexity of the installation. For large rivers where the installation must be conducted from the bridge deck, the level of effort required for installation of an instrument system can be 4-6 person days, plus the necessary equipment for installation.

7.3.7 Summary

The two instruments developed under NCHRP Project 21-3, a low-cost sonic system and either a manual-readout or automated magnetic sliding collar device, have been tested

extensively and are fully field-deployable. Use of these instruments as scour monitoring countermeasures will provide state highway agencies with an essential element of their plans of action for many scour-critical, scour-susceptible, or unknown foundation bridges.

No single methodology or instrument can be utilized to solve the scour monitoring problems for all situations encountered in the field. Considering the wide range of operating conditions necessary, environmental hazards such as debris and ice, and the variety of stream types and bridge geometries encountered in the field, it is obvious that several instrument systems using different approaches to detecting scour will be required.

Under NCHRP Project 21-3, a variety of scour measuring and monitoring methods were tested in the laboratory and in the field, including sounding rods, driven rod devices, fathometers, and buried devices. Two instrument systems, a low-cost bridge deck (above water) serviceable fathometer and a magnetic sliding collar device using a driven rod approach were installed under a wide range of bridge substructure geometry, flow, and geomorphic conditions. **Both instrument systems met all of the mandatory criteria and most of the desirable criteria established for this project.**

The Installation, Operation, Fabrication Manuals for the low-cost sonic system and magnetic sliding collar devices^(69,70) provide complete instrument documentation, including specifications and assembly drawings. That information, together with the findings, appraisal, and applications information of the final report,⁽⁶²⁾ provide a potential user of a scour monitoring device complete guidance on selection, installation, operation, maintenance, and if desired, fabrication of two effective systems, one of which could meet the need for a fixed scour instrument at most sites in the field.

Of the devices tested extensively in the field, the low-cost sonic system and the manual-readout sliding collar device are both vulnerable to ice and debris; however, both proved to be surprisingly resistant to damage from debris or ice impact at field test sites. The sonic system can be rendered inoperative by the accumulation of debris, and presumably ice, between the transducer face and streambed. The manual-readout sliding collar requires an extension conduit, generally up the front face of a pier, which can be susceptible to debris or ice impact damage unless the extension can be firmly anchored to a substructure element. From this perspective, the automated sliding collar device (or the driven rod with piezoelectric film sensors) has the distinct advantage of having a configuration which places most of the device below the streambed, and therefore, less vulnerable to ice or debris. The connecting cable from the device to a datalogger on the bridge deck can be routed through a buried conduit and up the downstream face of a bridge pier or abutment where it is much less vulnerable to damage.

7.4 SELECTING INSTRUMENTATION

Developing the monitoring program in a plan of action requires identifying the specific instruments, portable and/or fixed, and how they will be used to monitor scour. Selection of the appropriate instrumentation will depend on site conditions (streambed composition, bridge height off water surface, flow depth and velocity, etc.) and operational limitations of specific instrumentation (e.g., as related to high sediment transport, debris, ice, specialized training necessary to operate a piece of equipment, etc.).

Engineering judgment will always be required in designing instrument specifications to maximize the scour information collected within the given resources. Specific issues related to the use of either fixed or portable instruments include:

1. For fixed instrumentation, the number and location of instruments will have to be defined, as it may not be practical or cost effective to instrument every pier and abutment.
2. For portable instrumentation, the frequency of data collection and the detail and accuracy required will have to be defined, as it may not be possible to complete detailed bathymetric surveys at every pier or abutment during every inspection.

Most monitoring programs will involve a mix of fixed, portable and geophysical instruments to collect data in the most efficient manner possible. Furthermore, portable instrumentation should be used to ground-truth fixed instrumentation to insure accurate results and to evaluate potential shifting of the location of maximum scour.

Table 7.2 summarizes the advantages and limitations of the various instrumentation categories. In general, fixed instrumentation is best used when ongoing monitoring is required, recognizing that the location of maximum scour may not always be where the instrument was originally installed. This could be the result of geomorphic conditions and changes in the river over time, or an initial miscalculation when the instrument was installed. Portable instruments are best used where more areal coverage is required, either at a given bridge or at multiple bridges. Portable instruments provide flexibility and the capability to respond quickly to flood conditions; however, if a portable monitoring program becomes large, collecting data may become very labor intensive and costly. Additionally, deployment of portable instruments may require specialized platforms, such as trucks with cranes or booms, or the use of an under bridge inspection truck. Geophysical instrumentation is best used as a forensic tool, to evaluate scour conditions that existed during a previous flood. The primary limitation of geophysical equipment is the specialized training and cost involved in making this type of measurement.

Instrument Category	Advantages	Limitations
Fixed	Continuous monitoring, low operational cost, easy to use	Maximum scour not at instrument location, maintenance/loss of equipment
Portable	Point measurement or complete mapping, use at many bridges	Labor intensive, special platforms often required
Geophysical	Forensic investigations	Specialized training required, labor intensive
Positioning	Necessary for portable and geophysical	

Within the portable instrument category, the use of physical probes is generally limited to smaller bridges and channels (Table 7.3). It is a simple technology that can be effectively used by personnel with limited training, but may be of limited use as the flow depth or velocity increase, such as during flood conditions. Portable sonar instruments may be better suited for large bridges and channels, but they too can be limited by flow conditions based on the deployment options available. Sonar may also be limited in high sediment or air entrainment conditions, or when debris or ice accumulation are present.

	Best Application	Advantages	Limitations
Physical Probes	Small bridges and channels	Simple technology	Accuracy, high flow application
Sonar	Larger bridges and channels	Point data or complete mapping, accurate	High flow application

Fixed instrument devices include sonar, sounding rods (automated physical probe), magnetic sliding collar and float out devices (Table 7.4). Based on field experience, the sonar type devices work best in coastal regions and can be built using readily available components. They provide a time history of scour, yet have difficulty in conditions with high debris, ice, and air entrainment. Therefore, if a sonar device is selected for a riverine environment, these conditions may limit when data is collected and the quality of the data record. Sounding rods, typically a dropping rod with a method to measure the displacement occurring, have been found to work best in coarse bed channels, and are a simple mechanical type of device. They have had difficulty in channels with fine sediments where sediment accumulation around the sliding components has led to binding. Additionally, they are limited by the maximum amount of travel that the sounding rod can realistically achieve, given problems with unsupported length vibration and augering. In contrast, the magnetic sliding collar device works best in fine bed channels, where it is possible to drive the supporting rod into the streambed. It too is a simple, mechanical type device, but is also limited by concerns with unsupported length, binding and debris. The float out type sensors have worked well in ephemeral channels, and are a low-cost addition to any other type of fixed instrument installation. They have been successfully used when buried either in the channel bed, or in riprap, and can be placed at locations away from structural members of the bridge, which is not as readily possible with the other types of fixed instruments.

	Best Application	Advantages	Disadvantages
Sonar	Coastal regions	Time history, can be built with off-the-shelf components	Debris, high sediment or air entrainment
Sounding Rods	Coarse-bed channels	Simple, mechanical device	Unsupported length, binding, augering
Magnetic Sliding Collar	Fine-bed channels	Simple, mechanical device	Unsupported length, binding, debris
Float out	Ephemeral channels	Lower cost, ease of installation	battery life

Positioning equipment is required to provide location information with any portable or geophysical measurement (Table 7.5). The approximate methods are useful for any type of reconnaissance or inspection level monitoring, but are obviously limited by accuracy. The use of standard land survey techniques, using a total station type instrument or in the case of hydrographic surveying, an automated range-azimuth type device, can provide very accurate positional data. However, these instruments require a setup location on the shoreline that may be difficult to find during flooding, when overbank water and/or riparian vegetation limit access and line-of-sight. These approaches can also be somewhat slow and labor intensive. In contrast, the use of GPS provides a fast, accurate measurement, but will not work under the bridge.

	Best Application	Advantages	Limitations
Approximate methods	Recon or inspection	No special training or equipment	Accuracy
Traditional land survey methods	Small channels or areal surveys	Common technique using established equipment	Shore station locations, labor intensive
GPS	Measurement up to bridge face	Fast, accurate	Cannot work under bridge

Another important factor in designing a monitoring program is the cost of the instrumentation and data collection program. Instrument costs can be readily identified, but the cost of installation and operation are more difficult to quantify, since this will depend on site specific conditions and the amount of data needed. Based on field experience, Table 7.6 provides general guidelines on cost information. These costs should be used cautiously in an absolute sense, given unique site-specific conditions and/or the changes in cost that can occur with time and new research and development. This information may be most useful as a relative comparison between different approaches.

	Instrument Cost	Cost for Installation or Use	Operation Cost
Physical Probes	< \$2000	varies by use	varies, minimum 2-person crew for safety
Portable Sonar	fish-finder - \$500; survey grade - \$15,000 +/-	varies by use	varies, minimum 2-person crew for safety
Fixed Sonar	\$5,000-15,000	minimum 5-person days to install	typically < 1/hr per visit to site
Sounding Rod	\$7,500-10,000	minimum 5-person days to install	typically < 1/hr per visit to site
Magnetic Sliding Collar	\$5,000-10,000	minimum 5-person days to install	typically < 1/hr per visit to site
Float Out	\$3,000 + \$500/float out	varies with number installed	typically < 1/hr per visit to site
Approx Positioning	negligible	varies	1-2 person crew
Traditional land survey	\$10,000 +/-	varies	2-3 person crew
GPS	\$5,000 for submeter accuracy, \$20,000 + for centimeter	varies	1-2 person crew

7.5 FIXED INSTRUMENT FIELD INSTALLATIONS

7.5.1 Introduction

The Federal Highway Administration (FHWA) demonstration projects involve more than just lecture based training, typically by incorporating on-site demonstration of equipment or technology. Demonstration Project 97 (DP-97), "Scour Monitoring and Instrumentation,"^(13, 65) was initiated in 1993 to respond to the need for new and innovative techniques to measure and monitor scour at bridges. DP97 was completed in March 2000. A condensed version of this demonstration project will be available through FHWA's National Highway Institute (NHI) as an instructional module of the "Countermeasures Design for Stream Stability and Scour" training course.

The primary emphasis of DP-97 was 1.5 days of training that included equipment/instrumentation demonstrations. The project also offered technical assistance to states interested in the application of scour monitoring technology. Technical assistance included providing equipment to install or deploy on scour critical-bridges, on-site support during installations, engineering design services related to instrumentation, or technical advice.

This component of DP-97 was implemented as states completed the scour evaluation process and began to address what to do with bridges categorized as scour-critical. This section summarizes the installation experience gained to-date with a variety of scour monitoring instrument systems.

7.5.2 Typical Field Installations

Technical assistance provided under DP-97 ranged from telephone consultation to equipment and/or on-site engineering support. Technical advice was often requested after a state had completed the 1.5 day training and began to consider using instrumentation on scour-critical bridges. Questions on equipment applications or variations to meet site-specific conditions were common. The following case studies illustrate specific examples of technical assistance that was provided under DP-97.

New York Installations. In 1994, two scour monitoring devices were installed by the U.S. Geological Survey (USGS) and the New York State Department of Transportation (NYSDOT).⁽⁷⁸⁾ A manual read-out magnetic sliding collar device⁽⁶⁹⁾ was installed at State Route 30/145 over Schoharie Creek near Middleburg, New York. Before installation, NYSDOT backfilled a scour hole that partly exposed the footing with sand, gravel and cobbles, and then used a drill rig to create a hole where the stainless steel pipe for the instrument was placed. This was the first time an instrument was installed in a pre-drilled hole, which worked well. During the test period, no significant scour occurred due to low flow conditions; however, there was also no damage due to ice or debris which had been a concern at this location.

A low-cost sonar device⁽⁷⁰⁾ was also installed at the U.S. 418 bridge over the Hudson River near Warrensburg, New York, to monitor the stability of rock installed at the base of a pier by NYSDOT. Given significant ice loading and concern for potential damage to the sonar transducer conduit, the conduit was embedded in the nose of the pier by cutting a notch, placing the conduit in the notch, and then grouting over the conduit. On-site engineering support was provided during installation, as well as technical assistance before and after installation. After nine site inspections, the USGS reported that the instrument performed well and was not damaged by ice or debris. This instrument provided valuable insight on

sonar performance in ice-laden water and the adaptability of incorporating the instrument directly into the bridge structure.

Texas Installations. In 1994, sliding collar devices and sonar devices were installed by the Texas Department of Transportation. A manual-readout sliding collar device was installed on the U.S. 380 bridge over Double Mountain Fork of the Brazos River. A stainless steel pipe was driven into the bed with a gasoline powered driver. In the past, more than 6.1 m (20 ft) of scour had been reported at this bridge. Subsequently, the sliding collar successfully recorded a scour episode of approximately 1.5 m (5 ft).

Three sonar devices were also installed at bridges in the southeastern part of the state. During the test period, no scour occurred. However, these sonar devices demonstrated the urgent need for telemetry (remote data access) on narrow bridges where lane-closures were required to reach an instrument enclosure (box with the instrument electronics) located on the bridge. Additionally, the first underwater sonar transducer was installed at the U.S. 59 bridge over the Trinity River.

Indiana Installations. In 1997, technical assistance and on-site support were provided for two automated magnetic sliding collar devices and two sonar devices for the Indiana Department of Transportation (INDOT). A sliding collar and a sonar device were placed on the same pier on the US 52 bridge over the Wabash River, and the other two instruments were placed on the same pier on the SR 26 bridge over Wildcat Creek.

These installations used line power (instead of solar power) and short-haul modems to transmit the data from the instrument shelter on the bridge to a power pole located on the river bank. Using line power eliminated potential solar panel and battery damage from either environmental conditions or vandalism. The short haul modems provided reliable, remote data access capability. Line power and this type of modem had not been used previously, and these installations demonstrated the feasibility of these concepts. After the installation was completed, INDOT added steel angle on the piers to protect the conduit from debris, a valuable improvement on rivers carrying large debris.

California, Arizona and Nevada Installations. In preparation for El Niño driven storm events, a variety of instruments were installed at bridges in the southwest in late 1997 and early 1998. Five bridges were instrumented in California, five in Arizona and four in Nevada. The equipment included automated sliding collar devices, low-cost sonar, multi-channel sonar, float-out transmitters and sliding rod devices (Figures 7.13 and 7.14). These installations provided an opportunity to test a number of new concepts, including 2- and 4-channel sonar devices, application of early warning concepts (by defining threshold scour levels and automated calls to pagers when that threshold was exceeded), and development and refinement of the float-out instrument concept.

To support the California, Arizona, and Nevada installations, a buried transmitter "float out" device was developed for application on bridge piers over ephemeral stream systems. This device consists of a radio transmitter buried in the channel bed at a pre-determined depth. When the scour reaches that depth, the float out device rises to the surface and begins transmitting a radio signal that is detected by a receiver in an instrument shelter on the bridge. Installation requires using a conventional drill rig with a hollow stem auger (Figure 7.15). After the auger reaches the desired depth, the float out transmitter is dropped down the center of the auger (Figure 7.16). Substrate material refills the hole as the auger is withdrawn.



Figure 7.13. Installation of a sonar scour monitor on Salinas River bridge near Soledad, California (Highway 101) by CALTRANS.



Figure 7.14. Close up of sonar scour monitor on Salinas River bridge near Soledad, CA.



Figure 7.15. CALTRANS drilling with hollow stem auger for installation of float out devices at Salinas River bridge (Highway 101) near Soledad, CA.



Figure 7.16. Installation of float out device on Salinas River bridge near Soledad, CA.

The float out device can be monitored by the same type of instrument shelter/data logger currently being used to telemeter low-cost fathometer or automated sliding collar data. The instrument shelter contains the data logger, cell-phone telemetry, and a solar panel/gell-cell battery for power (Figure 7.17). The data logger monitors the sliding collar and sonar scour instruments, taking readings every hour and transmitting the data once per day to a computer at a central location (e.g., DOT District). A threshold elevation is defined that, when reached, initiates a phone call to a pager network. The bridge number is transmitted as a numeric page, allowing identification of the bridge where scour has occurred. The float out devices are monitored continuously, and if one of these devices floats to the surface, a similar call is automatically made to the pager network.

Although the float out devices had not been tested extensively in the field, in late 1997 and early 1998 more than 40 float-out devices were installed at bridges in Arizona (4 bridges), California (1 bridge), and Nevada (4 bridges). Most devices were installed at various levels below the streambed as described above; however, several devices at bridges in Nevada were buried in riprap at the base of bridge piers to monitor riprap stability (Figure 7.18).

One of the bridges instrumented, the SR 101 bridge over the Salinas River, near Soledad, California, experienced several scour events that triggered threshold warnings during February 1998. In one case the automated sliding collar dropped 1.5 m (5 ft) causing a pager call-out. Portable sonar measurements confirmed the scour recorded by the sliding collar. Several days later, another pager call-out occurred from a float-out device buried about 4 m (13 ft) below the streambed (Figures 7.15 to 7.17).



Figure 7.17. Typical instrument shelter with data logger, cell-phone telemetry, and a solar panel/gel-cell for power.



Figure 7.18. Installation of a float out device by Nevada DOT to monitor riprap stability.

In both cases, the critical scour depth was about 6 m (20 ft) below the streambed and no emergency action was called for to insure public and/or bridge safety. Because pager call-out was ineffective in alerting maintenance personnel during nonoffice hours, a programmed voice synthesizer call-out to human-operated 24-hour communications centers was implemented at other bridges. This illustrates the importance of effective and well-defined communication procedures, and the on-going need for comprehensive scour training at all levels of responsibility.

CHAPTER 8

REFERENCES

1. Brown, S.A., 1985, "Design of Spur-type Streambank Stabilization Structures," FHWA/RD-84/101, FHWA, Washington, D.C.
2. Brown, S.A., 1985, "Streambank Stabilization Measures for Highway Engineers," FHWA/RD-84/100, FHWA, Washington, D.C.
3. Brown, S.A. and E.S. Clyde, 1989, "Design of Riprap Revetment," Hydraulic Engineering Circular No. 11, FHWA-IP-89-016, Washington, D.C.
4. Richardson, E.V., D.B. Simons, and P.F. Lagasse, 2001, "River Engineering for Highway Encroachments - Highways in the River Environment," Report FHWA NHI 01-004, Federal Highway Administration, Hydraulic Design Series No. 6, Washington, D.C.
5. Bradley, J.N., 1978, "Hydraulics of Bridge Waterways," Hydraulic Design Series No. 1, U.S. Department of Transportation, FHWA, Washington, D.C..
6. Army Corps of Engineers, 1981, "The Streambank Erosion Control Evaluation and Demonstration Act of 1974," Final Report to Congress, Executive Summary and Conclusions.
7. Keown, M.P., 1983, "Streambank Protection Guidelines for Landowners and Local Governments," U.S. Army Corps of Engineers, Waterways Experiment Station, Vicksburg, MS
8. Clopper, P.E., 1989, "Hydraulic Stability of Articulated Concrete Block Revetment Systems During Overtopping Flow," FHWA-RD-89-199, Office of Engineering and Highway Operations R&D, McLean, VA.
9. Clopper, P.E. and Y. Chen, 1988, "Minimizing Embankment Damage During Overtopping Flow," FHWA-RD-88-181, Office of Engineering and Highway Operations R&D, McLean, VA.
10. McCorquodale, J.A., 1991, "Guide for the Design and Placement of Cable Concrete Mats," Report Prepared for the Manufacturers of Cable Concrete.
11. McCorquodale, J.A., 1991, "Cable-tied Concrete Block Erosion Protection," Hydraulic Engineering '93, San Francisco, CA, Proceedings (1993), pp. 1367-1372.
12. Brice, J.C. and J.C. Blodgett, 1978, "Countermeasure for Hydraulic Problems at Bridges, Volumes 1 and 2," FHWA-RD-78-162 and 163, USGS, Menlo Park, CA.
13. Federal Highway Administration, 1998, "Scour Monitoring and Instrumentation," Demonstration Project 97 Participants Workbook, FHWA-SA-96-036, Office of Technology Applications, Washington, D.C.
14. Odgaard, A.J. and Y. Wang, 1991, "Sediment Management with Submerged Vanes, I and II," Journal of Hydraulic Engineering, ASCE Vol. 117, 3, Washington, D.C.

15. Karim, M., 1975, "Concrete Fabric Mat, " Highway Focus, Vol. 7.
16. Lagasse, P.F., E.V. Richardson, J.D. Schall, and G.R. Price, 1997, "Instrumentation for Measuring Scour at Bridge Piers and Abutments," NCHRP Report 396, Transportation Research Board, National Research Council, National Academy Press, Washington, D.C.
17. Clopper, P.E., 1992, "Protecting Embankment Dams with Concrete Block Systems," Hydro Review, Vol. X, No. 2, April.
18. Simons, D.B. and Y.H. Chen, 1984, "Hydraulic Tests to Develop Design Criteria for the Use of Reno Mattresses," Civil Engineering Department - Engineering Research Center, Colorado State University, Fort Collins, CO.
19. Fotherby, L.M. and J.F. Ruff, 1995, "Bridge Scour Protection System Using Toskanes - Phase 1," Pennsylvania Department of Transportation, Report 91-02.
20. Paice, C. and R. Hey, 1993, "The Control and Monitoring of Local Scour at Bridge Piers," Proceedings Hydraulic Engineering 1993, San Francisco, CA.
21. Bertoldi, D.A., J.S. Jones, S.M. Stein, R.T. Kilgore, and A.T. Atayee, 1996, "An Experimental Study of Scour Protection Alternatives at Bridge Piers," FHWA-RD-95-187, Office of Engineering and Highway Operations R&D, McLean, VA.
22. Chang, F. and M. Karim, 1972, "An Experimental Study of Reducing Scour Around Bridge Piers Using Piles," South Dakota Department of Highways, Report.
23. Lagasse, P.F., J.D. Schall, and E.V. Richardson, 2001, "Stream Stability at Highway Structures," Hydraulic Engineering Circular 20, Third Edition, FHWA NHI 01-002, Federal Highway Administration, U.S. Department of Transportation, Washington, D.C.
24. Richardson, E.V. and S.R. Davis, 2001, "Evaluating Scour at Bridges," Hydraulic Engineering Circular 18, Fourth Edition, FHWA NHI 01-001, Federal Highway Administration, U.S. Department of Transportation, Washington, D.C.
25. Molinas, A., 1990, "Bridge Stream Tube Model for Alluvial River Simulation" (BRI-STARS), User's Manual, National Cooperative Highway Research Program, Project No. HR15-11, Transportation Research Board, Washington, D.C.
26. U.S. Army Corps of Engineers, 1993, "Scour and Deposition in Rivers and Reservoirs," User's Manual, HEC-6, Hydrologic Engineering Center, Davis, CA.
27. Jones, J.S., 1989, "Laboratory Studies of the Effect of Footings and Pile Groups on Bridge Pier Scour," Proceeding of 1989 Bridge Scour Symposium, FHWA, Washington, D.C.
28. USACE and FHWA, 1997, Agreement for the Implementation of Scour Countermeasures to Protect Foundations of Scour Critical Bridges, Memorandum, Washington, D.C., February.

29. Federal Highway Administration, 1995, "Recording and Coding Guide for the Structure Inventory and Appraisal of the Nation's Bridges, Report No. FHWA-PD-96-001, U.S. Department of Transportation, Washington, D.C.
30. Sharp, J.J., 1981, "Hydraulic Modeling," Butterworth & Co., United Kingdom.
31. Shen, H.W., 1979, "Modeling of Rivers," John Wiley & Sons, NY.
32. Transportation Research Board (TRB), 1999, "1998 Scanning Review of European Practice for Bridge Scour and Stream Instability Countermeasures," National Cooperative Highway Research Program, Research Results Digest, Number 241, Washington, D.C.
33. Eisenhauer, N.O. and B. Rossbach, 1999, "Testing the Effectiveness of Scour Countermeasures by Physical Modeling," Federal Waterways Engineering and Research Institute (BAW), Karlsruhe, Germany, proceedings of the Transportation Research Board, 5th International Bridge Engineering Conference, April 3-5, 2000, Tampa, FL.
34. Resource Consultants & Engineers, 1994, "Sediment and Erosion Design Guide," prepared for Albuquerque Metro Arroyo and Flood Control Authority (AMAFCA), Albuquerque, NM.
35. Maynard, S.T., 1996, "Toe-Scour Estimation in Stabilized Bendways," ASCE Journal of Hydraulic Engineering, Vol. 122, No. 8, pp. 460-464.
36. Thorne, C.R. and S.R. Abt, 1993, "Velocity and Scour Prediction in River Bends," Contract Rep. HL-93-1, U.S. Army Engrs., Waterways Experiment Station, Vicksburg, MS.
37. Watanabe, Y., K. Hasegawa, and K. Houjyou, 1990, "Influence of Hydraulic Factors on River Bed Scour," Jour. Hydrosoci and Hydr. Engrg., Tokyo, Japan.
38. Water Engineering & Technology, Inc. (WET), 1990, "Re-evaluation of the Streambank Erosion Control Evaluation and Demonstration Project," Report to U.S. Army Corps of Engineers, Vicksburg District, Contract No. DACW38-88-D-0099.
39. Begin, Z.B., 1981, "Stream Curvature and Bank Erosion: A Model Based on the Momentum Equation," Journal of Geology, Vol. 89, pp. 497-504.
40. Hoffmans, G.J.C.M. and H.J. Verheij, 1997, "Scour Manual," A.A. Balkema: Rotterdam, Brookfield.
41. Parola, A.C., 1993, "Stability of Riprap at Bridge Piers," ASCE, Journal of Hydraulic Engineering, Vol. 119, No. 10, New York, NY.
42. Escarameia, M., 1998, "River and Channel Revetments - A Design Manual," Environment Agency R&D Publication 16, Thomas Telford, London.

43. Heibaum, M.H., 1999, "Scour Countermeasures Using Geosynthetics and Partially Grouted Riprap," Federal Waterways Engineering and Research Institute (BAW), Karlsruhe, Germany, proceedings of the Transportation Research Board, 5th International Bridge Engineering Conference, April 3-5, 2000, Tampa, FL.
44. Bezzola, G.R., 1999, "Artificial Armor Units for Protection Against Lateral Erosion," Laboratory of Hydraulics, Hydrology and Glaciology of the Swiss Federal Institute of Technology, Zurich, presented at NHI Course on Stream Stability and Scour at Highway Bridges, Wallingford, UK, April 28-30, 1999.
45. Federal Highway Administration, 1999, "1999 Scanning Review of New Zealand Practice for Bridge Scour and Stream Instability Countermeasures," (Draft), Office of Bridge Technology, Washington, D.C.
46. Holtz, D.H., B.R. Christopher, and R.R. Berg, 1995, "Geosynthetic Design and Construction Guidelines," National Highway Institute, Publication No. FHWA HI-95-038, Federal Highway Administration, Washington, D.C., May.
47. Racin, J.A., T.P. Hoover, C.M. Avila Crosset, 1997, "California Bank and Shore Rock Slope Protection," FHWA-CA-TL-10, California Department of Transportation, Office of New Technology and Research, Sacramento, CA, June.
48. Bentrup, G. and J.C. Hoag, 1998, "The Practical Streambank Bioengineering Guide: User's Guide for Natural Streambank Stabilization Techniques in the Arid and Semi-Arid Great Basin and Intermountain West," Interagency Riparian/Wetland Plant Development Project, USDA Natural Resources Conservation Service.
49. Johnson, A.W. and J.M. Stypula (eds.), 1998, "Guidelines for Bank Stabilization Projects in the Riverine Environments of King County, King County Department of Public Works, Surface Water Management Division, Seattle, WA.
50. U.S. Army Engineers Waterways Experiment Station (WES), 1998, "Streambank Stabilization Handbook," Veri-Tech, Inc., Vicksburg, MS.
51. The Federal Interagency Stream Restoration Working Group (FISRWG), 1998, "Stream Corridor Restoration: Principles, Processes, and Practices," U.S. Dept. of Commerce, National Technical Information Service, Washington, D.C.
52. Schiechtl, H.M. and R. Stern, 1997, "Water Bioengineering Techniques for Water Course, Bank and Shoreline Protection," Blackwell Science, Inc., Cambridge, MA.
53. Morgan, R.P.C., A.J. Collins, M.J. Hann, J. Morris, J.A.L. Dunderdale, and D.J.G. Gowing, 1997, "Waterway Bank Protection: A Guide to Erosion Assessment and Management," Environment Agency, R&D Draft Technical Report W5/i635/3.
54. Whitlow, T.H. and R.W. Harris, 1979, "Flood Tolerance in Plants: A State-of-the-Art Review," Technical Report E-79-2, U.S. Army Engineer Waterways Experiment Station, Vicksburg, MS.
55. Brice, J.C., 1981, "Stability of Relocated Stream Channels," FHWA/RD-80/158, Federal Highway Administration, Washington, D.C., March.

56. Brice, J.C., 1984, "Assessment of Channel Stability at Bridge Sites," Transportation Research Record, Vol. 2, No. 950, Transportation Research Board, 2101 Constitution Avenue, Washington, D.C. 20418.
57. Brown, S.A., R.S. McQuivey, and T.N. Keefer, 1980, "Stream Channel Degradation and Aggradation: Analysis of Impacts to Highway Crossings," FHWA/RD-80-159, Federal Highway Administration, Washington, D.C.
58. Keeley, J.W., 1971, "Bank Protection and River Control in Oklahoma," Federal Highway Administration, Washington, D.C.
59. Richardson, E.V. and D.B. Simons, 1984, "Use of Spurs and Guidebanks for Highway Crossings," Transportation Research Board, Vol. 950, No. 2, Transportation Board, Washington, D.C., pp. 184-193.
60. Colson, B.E. and K.V. Wilson, 1973, "Hydraulic Performance of Bridges - Efficiency of Earthen Spur Dikes in Mississippi," MSHD-RD-73-15-SD, Mississippi State Highway Department, Jackson, Mississippi, in cooperation with the Federal Highway Administration.
61. Lagasse, P.F., P.L. Thompson, and S.A. Sabol, 1995, "Guarding Against Scour," *Civil Engineering*, American Society of Civil Engineers, June, pp. 56-59.
62. Lagasse, P.F., E.V. Richardson, J.D. Schall, G.R. Price, 1997, "Instrumentation for Measuring Scour at Bridge Piers and Abutments," NCHRP Report 396, Transportation Research Board, National Research Council, National Academy Press, Washington, D.C.
63. Lagasse, P.F., E.V. Richardson, J.D. Schall, J.R. Richardson, and G.R. Price, 1998, "Fixed Instrumentation for Monitoring Scour at Bridges," ASCE Compendium on Stream Stability and Scour at Bridges, Richardson, E.V. and Lagasse, P.F. (eds.), Reston, VA.
64. Lagasse, P.F., E.V. Richardson, and J.D. Schall, 1998, "Instrumentation for Monitoring Scour at Bridges," Transportation Research Record No. 1647, Highway Facility Design, Transportation Research Board, National Research Council, National Academy Press, Washington, D.C.
65. Ginsberg, A. and J.D. Schall, 1998, "Impact of Scour Monitoring and Instrumentation in the United States," ASCE, Proceedings of Water Resources Engineering '98, Memphis, TN, August 3-7.
66. Mueller, D.S. and M.N. Landers, 1999, "Portable Instrumentation for Real-Time Measurement of Scour at Bridges," Federal Highway Administration Publication No. FHWA-RD-99-085 (FHWA approval pending), Turner-Fairbank Highway Research Center, McLean, VA.
67. Barksdale, G. 1994, "Bridge Scour During the 1993 Floods in the Upper Mississippi River Basin," proceeding of the 1994 ASCE Hydraulic Engineering Conference.
68. Bath, W.R., 1999, "Remote Methods of Underwater Inspection of Bridge Structures," FHWA Report RD-99-100, Turner-Fairbank Highway Research Center, McLean, VA.

69. Schall, J.D., G.R. Price, G.A. Fisher, P.F. Lagasse, and E.V. Richardson, 1997a, "Magnetic Sliding Collar Scour Monitor-Installation, Operation, and Fabrication Manual," NCHRP Report 397B, Transportation Research Board, National Research Council, National Academy Press, Washington, D.C.
70. Schall, J.D., G.R. Price, G.A. Fisher, P.F. Lagasse, and E.V. Richardson, 1997b, "Sonar Scour Monitor-Installation, Operation, and Fabrication Manual," NCHRP Report 397A, Transportation Research Board, National Research Council, National Academy Press, Washington, D.C.
71. Lagasse, P.F., C.F. Nordin, J.D. Schall, and G.V. Sabol, 1991, "Scour Monitoring Devices for Bridges," Third Bridge Engineering Conference, Transportation Research Record No. 1290, Denver, CO, Transportation Research Board, National Research Council, Washington, D.C., March 10-13, pp. 281-294.
72. Melville B.W., R. Ettma, and S.C. Jain, 1989, "Measurement of Bridge Scour," Bridge Scour Symposium, Turner-Fairbank Highway Research Center, cosponsored by Federal Highway Administration and Subcommittee of Sedimentation, Interagency Advisory Committee on Water Data, OWDC, USGS, October 17-19, pp. 183-194.
73. Waters, C.R., 1994, "The HR Wallingford Scour Monitoring System," Centenary Year Bridge Conference, Cardiff, United Kingdom, September 26-30, pp. 323-328.
74. Landers, M.N. and R.E. Trent, 1991, "National Bridge Scour Data Collection Program," 1991 National Conference, Hydraulics Division, American Society of Civil Engineers, Nashville, TN (July 29-August 2), pp. 221-226.
75. Gorin, S.R. and F.P. Haeni, 1989, "Use of Surface-Geophysical Methods to Assess Riverbed Scour at Bridge Piers," *Water Resources Investigations Report 88-4212*, U.S. Geological Survey, Reston, Virginia, Water Resources Div., in cooperation with Federal Highway Administration, Hartford, CT, 33 pp.
76. Crumrine, M.D., K.K. Lee, and R.L. Kittelson, 1996, "Bridge-Scour Instrumentation and Data for Nine Sites in Oregon, 1991-94," *U.S. Geological Survey Open-File Report 95-366*, prepared in cooperation with the Oregon Department of Transportation, Portland, OR.
77. Zabilansky, L.J., 1996, "Ice Force and Scour Instrumentation for the White River, Vermont," *U.S. Army Corps of Engineers, Special Report 96-6*, Cold Regions Research & Engineering Laboratory, Hanover, NH, April, 53 pp.
78. Butch, G., 1996, "Evaluation of Scour Monitoring Instruments in New York," 1996 North American Water and Environment Congress '96--Bridge Scour Symposium, Hydraulics Division, American Society of Civil Engineers, Anaheim, CA , June 22-28.

DESIGN GUIDELINE 1
BENDWAY WEIRS/STREAM BARBS

(page intentionally left blank)

DESIGN GUIDELINE 1

BENDWAY WEIRS/STREAM BARBS

1.1 INTRODUCTION

Bendway weirs, also referred to as stream barbs, bank barbs, and reverse sills, are low elevation stone sills used to improve lateral stream stability and flow alignment problems at river bends and highway crossings. Bendway weirs are used for improving inadequate navigation channel width at bends on large navigable rivers. They are used more often for bankline protection on streams and smaller rivers. The stream barb concept was first introduced in the Soil Conservation Service (now the Natural Resource Conservation Service, NRCS) by Reichmuth⁽¹⁾ who has applied these rock structures in many streams in the western United States.

The U.S. Army Corps of Engineers Waterways Experiment Station (WES) developed a physical model to investigate the bendway weir concept in 1988^(2,3). Since then WES has conducted 11 physical model studies on the use of bendway weirs to improve deep and shallow-draft navigation, align currents through highway bridges, divert sediment, and protect docking facilities. WES has installed bendway weirs to protect eroding banklines on bends of Harland Creek near Tchula, Mississippi. The U.S. Army Corps of Engineers, Omaha District, has used bendway weirs on the Missouri River in eastern Montana. The Missouri River Division (MRD) Mead Hydraulic Laboratory has also conducted significant research and testing of underwater sills. Bendway weirs are a relatively new river training structure and research is providing useful information on their use and effectiveness.

1.2 DESIGN CONCEPT

Bendway weirs are similar in appearance to stone spurs, but have significant functional differences. Spurs are typically visible above the flow line and are designed so that flow is either diverted **around** the structure, or flow along the bank line is reduced as it passes **through** the structure. Bendway weirs are normally not visible, especially at stages above low water, and are intended to redirect flow by utilizing weir hydraulics **over** the structure. Flow passing over the bendway weir is redirected such that it flows perpendicular to the axis of the weir and is directed towards the channel centerline. Similar to stone spurs, bendway weirs reduce near bank velocities, reduce the concentration of currents on the outer bank, and can produce a better alignment of flow through the bend and downstream crossing. **Experience with bendway weirs has indicated that the structures do not perform well in degrading or sediment deficient reaches.**

Bendway weirs have been constructed from stone, tree trunks, and grout filled bags and tubes. Design guidance for bendway weirs has been provided by the U.S. Army Corps of Engineers, Omaha District, WES, and the NRCS. The following geometric design guidelines for stone bendway weirs reflect guidance provided by LaGrone⁽⁴⁾, Saele⁽⁵⁾ and Derrick^(6,7,8). The formulas provided by LaGrone were developed to consolidate many of the "rules of thumb" that currently exist in the field. The formulas are not based on exhaustive research, but appear to match well to current practices. Installation examples were provided by Colorado Department of Transportation (CDOT), Washington State Department of Transportation (WSDOT), and Tennessee Department of Transportation, TDOT.

1.3 DESIGN GUIDELINES

1. HEIGHT - The height of the weirs, H , is determined by analyzing various depths of flow at the project site (Refer to Figures 1.1 and 1.2). The bendway weir height should be between 30 to 50 percent of the depth at the mean annual high water level. The height of the structure should also be below the normal or seasonal mean water level and should be equal to or above the mean low water level. The weir must be of adequate height to intercept a large enough percentage of the flow to produce the desired results. For applications relating to improved navigation width, the weir must be at an elevation low enough to allow normal river traffic to pass over the weir unimpeded.

2. ANGLE - The angle of projection, θ , between the bendway weir axis and the upstream bankline tangent typically ranges from 50 to 85 degrees. Experience has indicated that it is easier to measure this angle from the chord between two weirs in the field rather than using the bankline tangent. The chord is drawn from the points of intersection with the weirs and the bankline (Figure 1.1). The angle of projection is determined by the location of the weir in the bend and the angle at which the flow lines approach the structure. Ideally, the angle should be such that the high-flow streamline angle of attack is not greater than 30 degrees and the low-flow streamline angle of attack is not less than 15 degrees to the normal of the weir centerline of the first several weirs. If the angle of flow approaching the upstream weirs is close to head-on, then the weir will be ineffective and act as a flow divider and bank scalloping can result. If the angle of flow approaching the upstream weirs is too large then the weir will not be able to effectively redirect the flow to the desired flow path. Ideally, the angle should be such that the perpendicular line from the midpoint of an upstream weir points to the midpoint of the following downstream weir. All other factors being equal, smaller projection angles, θ , would need to be applied to bends with smaller radii of curvature to meet this criteria and vice versa. Experiments by Derrick⁽⁶⁾ resulted in a weir angle, θ , of 60 degrees being the most effective for the desired results in a physical model of a reach on the Mississippi River. Observations by LaGrone,⁽⁴⁾ indicate that the angle, θ , of the upstream face of the structure is most important in redirecting flows. The upstream face should be a well defined straight line at a consistent angle.

3. CROSS SECTION - The transverse slope along the centerline of the weir is intended to be flat or nearly flat and should be no steeper than 1V:5H. The flat weir section normally transitions into the bank on a slope of 1V:1.5H to 1V:2H. The structure height at the bankline should equal the height of the maximum design high water. This level is designed using sound engineering judgment. The key must be high enough to prevent flow from flanking the structure. The bendway weir should also be keyed into the stream bed a minimum depth approximately equal to the D_{100} size, but also below the anticipated long-term degradation and contraction scour depth.

4. LENGTH - The bendway weir length (L) should be long enough to cross the stream thalweg; however, should not exceed 1/3 the mean channel width (W). A weir length greater than 1/3 of the width of the channel can alter the channel patterns which can impact the opposite bankline. Weirs designed for bank protection need not exceed 1/4 the channel width. A length of 1.5 to 2 times the distance from the bank to the thalweg has proven satisfactory on some bank stabilization projects. The length of the weir will affect the spacing between the weirs.

$$\text{Maximum Length } L = W/3 \quad (\text{typically: } W/10 < L < W/4) \quad (1.1)$$

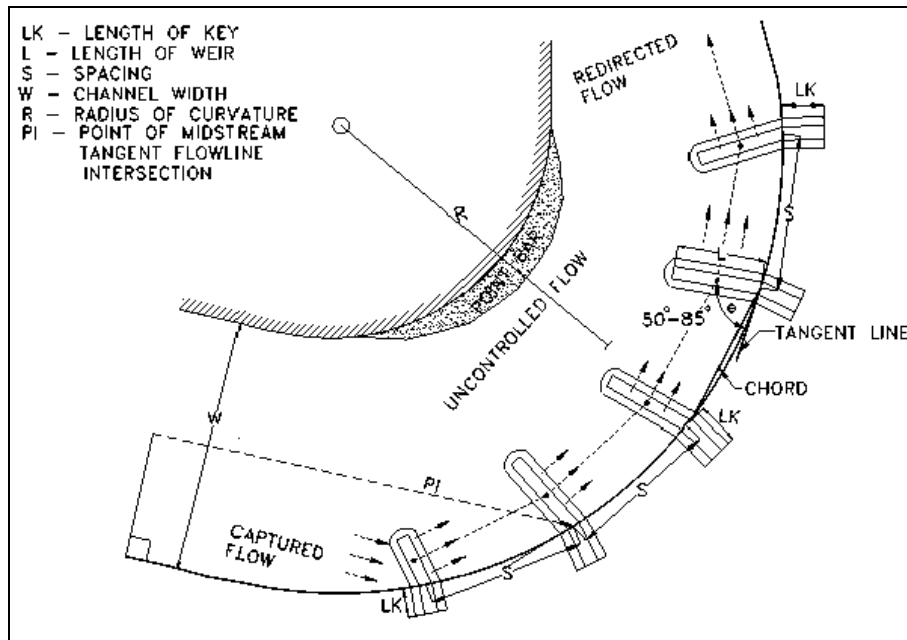

Figure 1.1. Bendway weir typical plan view.

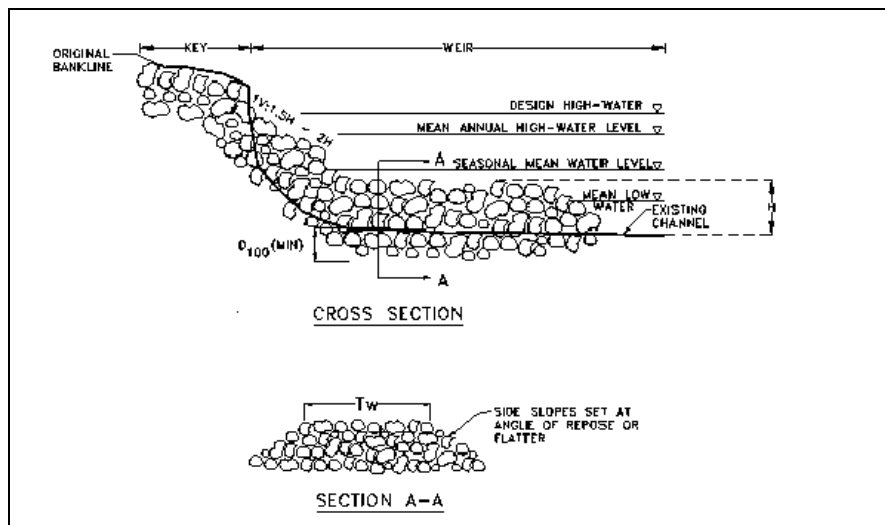

Figure 1.2. Bendway weir typical cross section.

5. LOCATION - Ideally, a short weir should be placed a distance (S) upstream from the location where the midstream tangent flow line (midstream flow line located at the start of the curve) intersects the bankline (PI). Additional bendway weirs are then located based on the site conditions and sound engineering judgment. Typically, the weirs are evenly spaced a distance (S) apart (Figure 1.1).

6. SPACING - Bendway weir spacing is influence by several site conditions. The following guidance formulas are based on a cursory review of the tests completed by WES on bendway weirs and on tests completed by MRD on underwater sills. Based on the review, bendway weirs should be spaced similarly to hardpoints and spurs. Weir spacing is dependent on the streamflow leaving the weir and its intersection with the downstream structure or bank. Weir spacing (S) is influenced by the length of the weir (L), and the ratios of weir length to channel width (W) and channel radius of curvature (R) to channel width. Spacing can be computed based on the following guidance formulas.^(4, 5)

$$S = 1.5L \left(\frac{R}{W} \right)^{0.8} \left(\frac{L}{W} \right)^{0.3} \quad (1.2)$$

$$S = (4 \text{ to } 5)L \quad (1.3)$$

The spacing selected should fall within the range established by Equations 1.2 and 1.3, depending on bendway geometry and flow alignment. The spacing should not exceed the maximum established by Equation 1.4. Maximum Spacing (S_{\max}) is based on the intersection of the tangent flow line with the bankline assuming a simple curve. The maximum spacing is not recommended, but is a reference for designers. In situations where some erosion between weirs can be tolerated, the spacing may be set between the recommended and the maximum.⁽⁴⁾

$$S_{\max} = R \left(1 - \left(1 - \frac{L}{R} \right)^2 \right)^{0.5} \quad (1.4)$$

Results from the spacing formulas should be investigated to determine if the weir spacing, length, and angle would redirect the flow to the desired location. Streamlines entering and exiting the weirs should be analyzed and drawn in planform.

7. LENGTH OF KEY - Bendway weirs like all bankline protection structures should be keyed into the bankline to prevent flanking by the flow. Typically the key length (LK) is about half the length of the short weirs and about one fifth the length of the long weirs. Tests conducted by MRD found that lateral erosion between spurs on nearly straight reaches could be estimated by using a 20 degree angle of expansion (Figure 1.3). The following guidance formulas for LK were therefore developed. **These formulas compute minimum LK which should be extended in critical locations.** The need for a filter between the weir key and the bank material should also be determined. Guidelines for the selection, design, and specification of filter materials can be found in (HEC-11)⁽⁹⁾ and Holtz et al. (FHWA HI-95-038).⁽¹⁰⁾

When the channel radius of curvature is large⁽⁴⁾ ($R > 5W$) and $S > L/\tan(20^\circ)$

$$LK = S \tan(20^\circ) - L \quad (1.5)$$

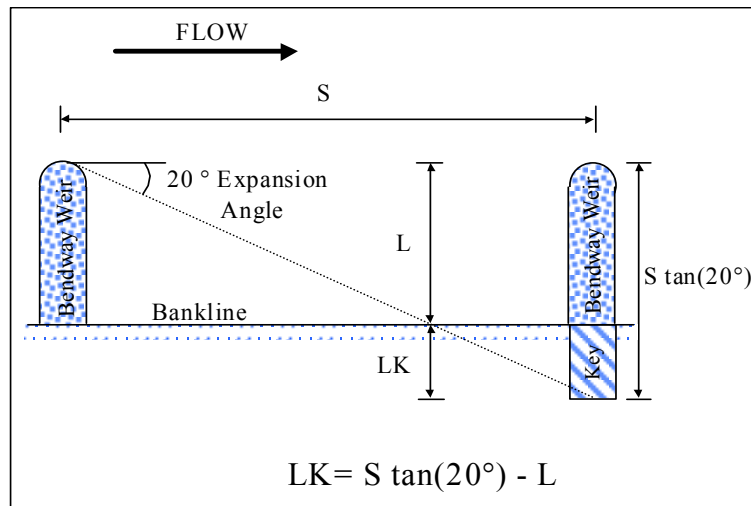

Figure 1.3. Length of key for mild bends.

When the channel radius of curvature is small⁽⁴⁾ $R < 5W$ and $S < L/\tan(20^\circ)$

$$LK = \frac{L}{2} \left(\frac{W}{L} \right)^{0.3} \left(\frac{S}{R} \right)^{0.5} \quad (1.6)$$

NOTE: LK should not be less than 1.5 times the total bank height.

The NRCS guideline for length of key (LK) for short weirs or barbs⁽⁵⁾ is to key the barb into the bank a minimum distance of 2.4 m (8 ft) or 4 (D_{100}) which ever is greater.

8. TOP WIDTH - The top width of the weir may vary between 1 m and 4 m (3 and 12 ft), but should be no less than $(2 \text{ to } 3) \cdot D_{100}$. Weirs over 9 m (30 ft) in length will have to be built either from a barge or by driving equipment out on the structure during low flows. Structures built by driving equipment on the weir will need to be at least 3 to 5 m (10 to 15 ft) wide. Side slopes of the weirs can be set at the natural angle of repose of the construction material (1V:1.5H) or flatter.

9. NUMBER OF WEIRS - The smallest number of weirs necessary to accomplish the project purpose should be constructed. The length of the weirs and the spacing can be adjusted to meet this requirement. Typically, not less than three weirs are used together on unrevetted banks.

10. CONSTRUCTION - Construction of the bendway weirs are typically conducted during low flow periods for the affected river. Construction methods will vary depending on the size of the river. Construction on larger rivers may be conducted using a barge which would allow the rock to be placed without disturbing the bankline. For rivers where a barge is not available and where the bendway weir is longer than 9 m (30 ft), access will need to be made from the bank and equipment may need to be driven out on the weir as it is being constructed.

Supplemental information on the use of bendway weirs on tight bends (small radius of curvature) and complex meanders can be found in LaGrone.⁽⁴⁾

1.4 MATERIAL SPECIFICATIONS

1. Stone should be angular, and not more than 30 percent of the stone should have a length exceeding 2.5 its thickness.
2. No stone should be longer than 3.5 times its thickness.
3. Stone should be well graded but with only a limited amount of material less than half the median stone size. Since the stone will most often be placed in moving water, the smaller stone will be subject to displacement by the flow during installation.
4. Construction material should be quarry run stone or broken, clean concrete. High quality material is recommended for long-term performance.
5. Material sizing should be based on standard riprap sizing formulas for turbulent flow. Typically the size should be approximately 20 percent greater than that computed from nonturbulent riprap sizing formulas. The riprap D_{50} typically ranges between 300 mm and 910 mm (1 and 3 ft) and should be in the 45 kg to 450 kg (100 to 1,000 lb) range. The D_{100} rock size should be at least 3 times the calculated D_{50} size. The minimum rock size should not be less than the D_{100} of the streambed material.
6. Guidelines for the selection, design, and specification of filter materials can be found in HEC-11⁽⁹⁾ and Holtz et al. (FHWA HI-95-038)⁽¹⁰⁾.

1.5 BENDWAY WEIR DESIGN EXAMPLE (SI)

The following example illustrates the preliminary layout of bendway weirs for use in bank protection at a stream bend. The design uses guidelines provided in the previous sections.

Given:

The stream width is 30 m. The radius of the bend is 152 m. The bank height is 3 m, which is the mean annual high water level.

Develop a preliminary layout for bendway weir placement for bank protection at the stream bend. The preliminary layout should include weir height, weir length, key length, and weir spacing. Assume the stone size will be established in the final design of the system.

Step 1: Determine the weir height.

$H = 0.3$ to 0.5 of mean annual high water depth (use 0.3 for this problem)

$H = 0.3 (3.0 \text{ m}) = 0.9 \text{ m}$

Step 2: Determine the weir length.

$$L = W/3 \text{ for flow redirection}$$

$$L = W/4 \text{ for bank protection}$$

$$L = 30 \text{ m}/4 = 7.5 \text{ m}$$

Step 3: Determine the weir spacing.

$$S = 1.5L \left[\frac{R}{W} \right]^{0.8} \left[\frac{L}{W} \right]^{0.3}$$

$$S = 1.5(7.5) \left[\frac{152}{30} \right]^{0.8} \left[\frac{7.5}{30} \right]^{0.3} = 27.2 \text{ m}$$

Check against $S = 4(L) = 4(7.5 \text{ m}) = 30 \text{ m}$. Based on site conditions, use 30 m.

Check the maximum spacing, given by:

$$S_{\max} = R \left[1 - \left[1 - \frac{L}{R} \right]^2 \right]^{0.5}$$

$$S_{\max} = 152 \left[1 - \left[1 - \frac{7.5}{152} \right]^2 \right]^{0.5} = 47.2 \text{ m}$$

$S_{\max} > S$, continue:

Step 4: Determine the key length.

Check for $R > 5W$ and $S > L/\tan(20^\circ)$

$$R = 152 \text{ m and } W = 30 \text{ m, therefore } R > 5(W) = 150 \text{ m}$$

$$S = 30 \text{ m and } L = 7.5 \text{ m, therefore } S > L/\tan(20^\circ) = 20.6 \text{ m}$$

$$LK = S \tan(20^\circ) - L$$

$$LK = 30 \tan(20^\circ) - 7.5 = 3.4 \text{ m}$$

$$\text{Check against } LK > 1.5(\text{Bank Height}) = 1.5(3) = 4.5 \text{ m}$$

LK must be set to 4.5 m because this value is greater than the value computed first.

Step 5: Preliminary layout.

The preliminary layout for this stream bend as follows:

Height	H = 0.9 m
Length	L = 7.5 m
Spacing	S = 30 m
Length of key	LK = 4.5 m

1.6 BENDWAY WEIR DESIGN EXAMPLE (ENGLISH)

The following example illustrates the preliminary layout of bendway weirs for use in bank protection at a stream bend. The design uses guidelines provided in the previous sections.

Given:

The stream width is 100 ft. The radius of the bend is 500 ft. The bank height is 10 ft, which is the mean annual high water level.

Develop a preliminary layout for bendway weir placement for bank protection at the stream bend. The preliminary layout should include weir height, weir length, key length, and weir spacing. Assume the stone size will be established in the final design of the system.

Step 1: Determine the weir height.

$H = 0.3$ to 0.5 of mean annual high water depth (use 0.3 for this problem)

$$H = 0.3 (10 \text{ ft}) = 3 \text{ ft}$$

Step 2: Determine the weir length.

$L = W/3$ for flow redirection

$L = W/4$ for bank protection

$$L = 100 \text{ ft}/4 = 25 \text{ ft}$$

Step 3: Determine the weir spacing.

$$S = 1.5L \left[\frac{R}{W} \right]^{0.8} \left[\frac{L}{W} \right]^{0.3}$$

$$S = 1.5(25) \left[\frac{500}{100} \right]^{0.8} \left[\frac{25}{100} \right]^{0.3} = 90 \text{ ft}$$

Check against $S = 4(L) = 4(25 \text{ ft}) = 100 \text{ ft}$. Based on site conditions, use 100 ft.

Check against the maximum spacing, given by:

$$S_{\max} = R \left[1 - \left[1 - \frac{L}{R} \right]^2 \right]^{0.5}$$

$$S_{\max} = 500 \left[1 - \left[1 - \frac{25}{500} \right]^2 \right]^{0.5} = 156 \text{ ft}$$

$S_{\max} > S$, continue:

Step 4: Determine the key length.

Check for $R > 5W$ and $S > L/\tan(20^\circ)$

$R = 500$ ft and $W = 100$ ft, therefore $R > 5(W) = 500$ ft

$S = 100$ ft and $L = 25$ ft, therefore $S > L/\tan(20^\circ) = 68.7$ ft

$$LK = S \tan(20^\circ) - L$$

$$LK = 100 \tan(20^\circ) - 25 = 11.4 \text{ ft}$$

Check against $LK \geq 1.5(\text{Bank Height}) = 1.5(10) = 15$ ft

LK must be set to 15 ft because this value is greater than the value computed first.

Step 5: Preliminary Layout.

The preliminary layout for this stream bend as follows:

Height	$H = 3$ ft
Length	$L = 25$ ft
Spacing	$S = 100$ ft
Length of key	$LK = 15$ ft

1.7 INSTALLATION EXAMPLES

Some illustrations of bendway weirs in use are shown in Figures 1.4 - 1.7. Figures 1.4 and 1.5 show short bendway weirs shortly after installation by CDOT on the Blue River near Silverthorne, Colorado in February 1997. These weirs were designed with weir lengths of 3.5 - 6 meters (11.5 - 20 ft) at θ angles of 75° to the bankline tangent. The CDOT engineer indicated that adjustments in the field are equally as important and necessary as original design plans. It can be observed that the bendway weirs are being constructed at low flow conditions as discussed previously.

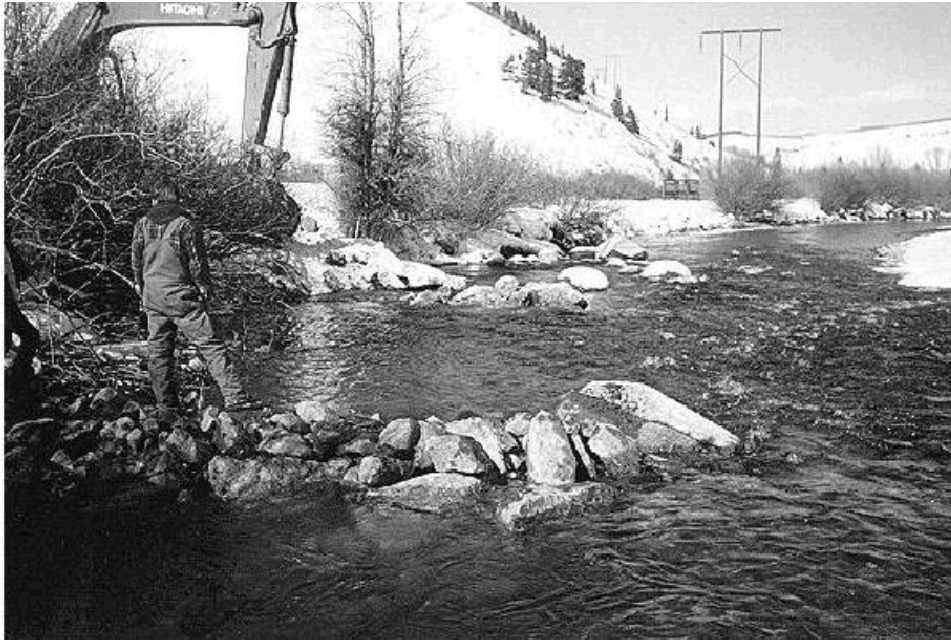

Figure 1.4. Bendway weirs installed on the Blue River near Silverthorne, Colorado (CDOT).



Figure 1.5. Bendway weirs installed on the Blue River near Silverthorne, Colorado (CDOT).

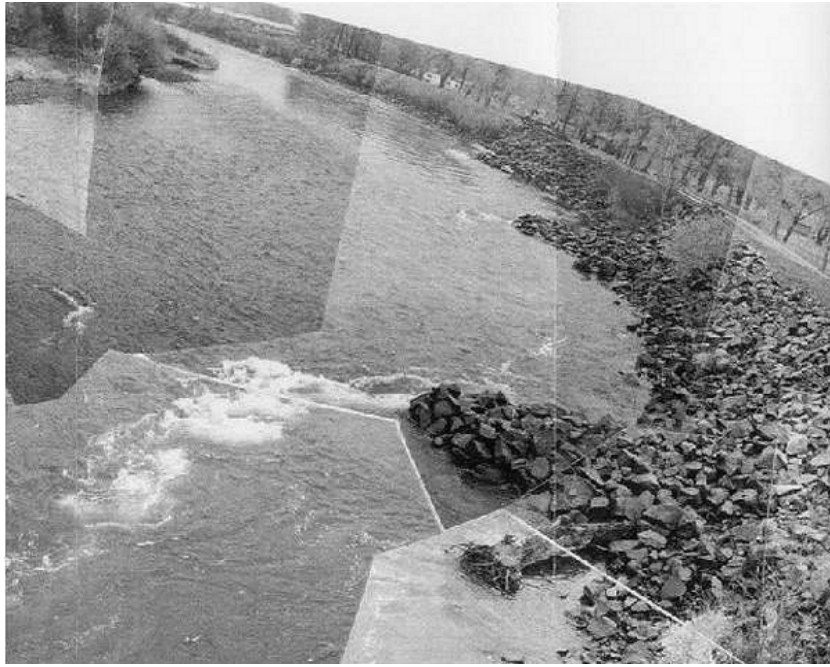

Figure 1.6. Bendway weirs on the Yakima River, Washington at low flow (WSDOT).



Figure 1.7. Submerged bendway weirs on the Yakima River, Washington at high flow (WSDOT).

Figures 1.6 and 1.7 show bendway weirs installed by WSDOT on the Yakima River, Washington in 1994. Figure 1.6 shows the weirs at low flow conditions and Figure 1.7 shows the submerged weirs at normal to high flow conditions. Surface disturbances as flow passes over the weirs can be observed in Figure 1.7. These weirs were designed at θ angles of 50° to the bankline tangent to direct flow away from a critical pier at a bridge just downstream of this bend.

1.8 CASE STUDY - BENDWAY WEIRS ON THE HATCHIE RIVER, TENNESSEE

On April 1, 1989 the north-bound bridge of U.S. Route 51 over the Hatchie River near Covington, Tennessee collapsed with the loss of eight lives. The flow was $244 \text{ m}^3/\text{s}$ (8,620 cfs) with a 2-year return period. However, the U.S. Geological Survey estimated that this 1989 flow was in the top 10 for overbank flow duration and the longest overbank flow duration since 1974.⁽¹¹⁾

The foundation of the bridge consisted of pile bents on the floodplain and piers in the channel. The bents were supported on 6.1 m (20 ft) long timber piles embedded 0.3 m (1 ft) into concrete pile caps. The bottom of the pile caps for the floodplain bents was at an elevation 4 to 4.3 m (13 to 14 ft) higher than for the piers (Figure 1.8). The floodplain and river channel were erodible silt, sand, and clay. The north bound bridge was built in 1936 and spanned 1,219 m (4,000 ft) of the floodplain on 143 simple spans. The south bound bridge was built in 1974 and narrowed the bridge opening to 305 m (1,000 ft) on 13 spans.

The bridges spanned the Hatchie River on a meander bend. Bend migration to the north was well documented. From 1931 to 1975 the migration rate averaged 0.24 m (0.8 ft) per year; 1975 to 1981 (after the south bound bridge was built) was 1.37 m (4.5 ft) per year; and 1981 to 1989 was 0.58 m (1.9 ft) per year (Figure 1.8). The migration was such that in 1989 bent 70 was exposed to the flow. The combination of channel migration and local pier scour caused the bent to fail.

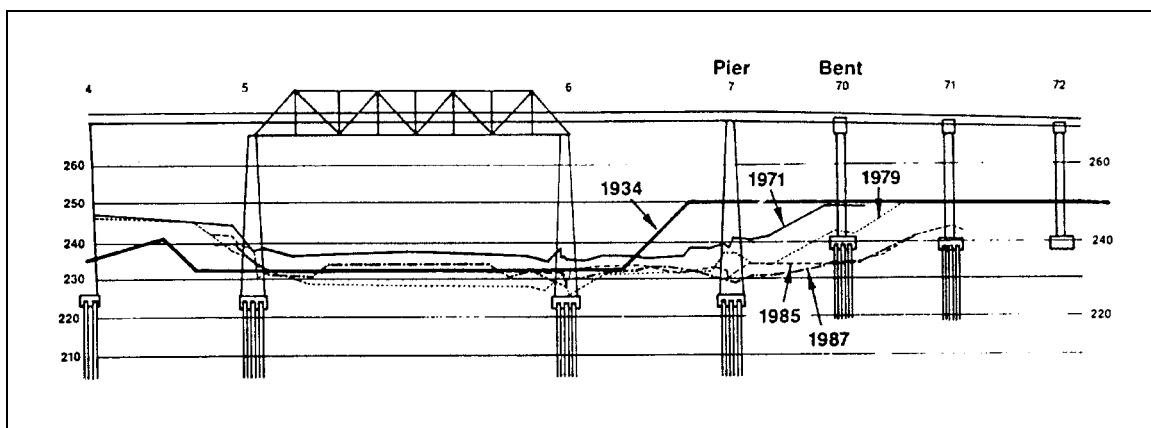

Figure 1.8. Documented channel migration of the Hatchie River, Tennessee.⁽¹¹⁾

The National Transportation Safety Board (NTSB)⁽¹²⁾ investigated the failure and gave as probable cause "...the northward migration of the main river channel which the Tennessee Department of Transportation failed to evaluate and correct. Contributing to the severity of the accident was the lack of redundancy in the design of the bridge spans."

After the failure of the Hatchie River bridge, TDOT experienced additional instability on the north bank of the river, upstream from the replacement bridge. The solution was to design and install bendway weirs along the north bank.⁽¹³⁾ A field of five bendway weirs was designed to halt the bank erosion. Design parameters were estimated using guidance from HEC-23 (First Edition). As part of the design process, a 2-dimensional hydraulic model was utilized. The model provided flow field data to refine and verify the bendway weir design. Construction was initiated and completed in the Fall of 1999. Figures 1.9 and 1.10 show the installed countermeasures at low flow.



Figure 1.9. Bendway weirs on northbank of Hatchie River looking upstream (TDOT).



Figure 1.10. Close up bendway weir on Hatchie River (TDOT).

1.9 REFERENCES

1. Reichmuth, D.R. 1993, "Living with Fluvial Systems," Workshop notes February 23 - 25, 1993, Portland, OR.
2. Watson, C.C., D. Gessler, S.R. Abt, C.I. Thornton, and P. Kozinski, 1996, "Demonstration Erosion Control Monitoring Sites, 1995 Evaluation," Annual Report DACW39-92-K-0003, Colorado State University, Fort Collins, CO.
3. U.S. Army Corps Engineers, "Bendway Weir Theory, Development, and Design," USACE Waterways Experiment Station Fact Sheet, Vicksburg, MS, undated document.
4. LaGrone, D.L., 1996, "Bendway Weir General Guidance Memorandum," U.S. Army Corps of Engineers, Omaha District, Omaha, NE, revised from 1995.
5. Saele, L.M., 1994, "Guidelines for the Design of Stream Barbs," Stream bank Protection & Restoration Conference, 9/22/1994 - 24/1994, SCS-WNTC, Portland, OR.
6. Derrick, D.L., 1994, "Design and Development of Bendway Weirs for the Dogtooth Bend Reach, Mississippi River, Hydraulic Model Investigation," Technical Report HL-94-10, WES, Vicksburg, MS.
7. Derrick, D.L., 1996, "The Bendway Weir: An Instream Erosion Control and Habitat Improvement Structure for the 1990's," Proceedings of Conference XXVII, International Erosion Control Association, 2/27/1996 - 3/1/1996, Seattle, WA.
8. Derrick, D.L., "Bendway Weirs Redirect Flow to Protect Highway Bridge Abutments," U.S. Army Corps of Engineers Waterways Experiment Station, Vicksburg, MS, undated document.
9. Brown, S.A. and E.S. Clyde, 1989, "Design of Riprap Revetment," Hydraulic Engineering Circular No. 11, FHWA-IP-016, prepared for FHWA, Washington, D.C.
10. Holtz, D.H., B.R. Christopher, and R.R. Berg, 1995, "Geosynthetic Design and Construction Guidelines," National Highway Institute, Publication No. FHWA HI-95-038, Federal Highway Administration, Washington D.C., May.
11. Bryan, B.S., 1989, "Channel Evolution of the Hatchie River near the U.S. Highway 51 Crossing in Lauderdale and Tipton Counties, West Tennessee," USGS Open-File Report 89-598, Nashville, TN.
12. NTSB, 1990, "Collapse of the Northbound U.S. Route 51 Bridge Spans over the Hatchie River near Covington, Tennessee," April 1, 1989, NTSB/HAR-90/01, National Transportation Safety Board, Washington, D.C.
13. Peck, W.W., 1999, "Two-Dimensional Analysis of Bendway Weirs at US-51 Over the Hatchie River," Proceedings, ASCE International Water Resource Engineering Conference, Session BS-2, August 8-12, Seattle, WA.

1.10 CONTACTS

Washington State Department of Transportation
P.O. Box 47300
Olympia, Washington 98504-7300

Colorado Department of Transportation
4201 East Arkansas Avenue
Denver, Colorado 80222

Tennessee Department of Transportation
505 Deadrick
James K. Polk Building, Suite 1100
Nashville, Tennessee 37243

(page intentionally left blank)

DESIGN GUIDELINE 2

SOIL CEMENT

(page intentionally left blank)

DESIGN GUIDELINE 2

SOIL CEMENT

2.1 INTRODUCTION

In areas where high quality rock is scarce, the use of soil cement can provide a practical countermeasure alternative for channel stability and scour protection. Soil cement has been used to construct drop structures and armor embankments, dikes, levees, channels, and coastal shorelines. Soil cement is frequently used in the southwestern United States because the limited supply of rock makes it impractical to use riprap for large channel protection projects.

2.2 DESIGN GUIDELINES

The following design guidelines reflect guidance in information provided by the Pima County Department of Transportation in Tucson, Arizona⁽¹⁾ and the Portland Cement Association.^(2,3,4,5,6) Typically, soil cement is constructed in a stair-step configuration by placing and compacting the soil cement in horizontal layers (Figure 2.1). However, soil cement can be placed parallel to the face of an embankment slope rather than in horizontal layers. This technique is known as plating.



Figure 2.1. Stair step facing on Bonny Reservoir, Colorado after 30 years (PCA).

2.2.1 Facing Dimensions for Slope Protection using Stair-Step Method

In stair-step installations soil cement is typically placed in 2.4-m (8 ft) wide horizontal layers. The width should provide sufficient working area to accommodate equipment. The relationship between the horizontal layer width (W), slope of facing (S), thickness of compacted horizontal layer (v), and minimum facing thickness measured normal to the slope (t_n) is quantified by the following equation:

$$W = t_n \sqrt{S^2 + 1} + vS \quad (2.1)$$

As illustrated in Figure 2.2, for a working width, W , of 2.4 m (8 ft), a side slope of 1V:3H (1V:(S)H), and individual layers, v , of 150 mm (6 in.) thick, the resulting minimum thickness, t_n , of facing would be 620 mm (24 in.) measured normal to the slope. Bank stabilization along major rivers in Pima County, Arizona is constructed by using 150 mm (6 in.) lifts of soil cement that are 2.4 m (8 ft) in width and placed on a 1V:1H face slope.

When horizontal layer widths do not provide adequate working widths, the stair-step layers can be sloped on a grade of 1V:8H or flatter toward the water line. Sloping the individual layers will provide a greater working surface without increasing the quantity of soil cement.

2.2.2 Facing Dimensions for Slope Protection Using Plating Method

On smaller slope protection projects a single layer of soil cement can be placed parallel to the embankment. In this technique, known as plating, a single lift of soil cement is applied on slopes of 1V:3H or flatter (Figure 2.3).

All extremities of the soil cement facing should be tied into nonerodible sections or abutments to prevent undermining of the rigid layer. Some common methods used to prevent undermining are placing a riprap apron at the toe of the facing, extending the installation below the anticipated degradation and contraction scour depth or providing a cutoff wall below that depth.

As with any rigid revetment, hydrostatic pressure caused by moisture trapped in the embankment behind the soil cement facing is an important consideration. Designing the embankment so that its least permeable zone is immediately adjacent to the soil cement facing will reduce the amount of water allowed to seep into the embankment. Also, providing free drainage with weep holes behind and through the soil cement will reduce pressures which cause hydrostatic uplift.

2.2.3 Grade Control Structures

Grade control structures (drop structures) are commonly used in Arizona to mitigate channel bed degradation (Figure 2.4). The location and spacing of grade control structures should be based on analysis of the vertical stability of the system. Toe-down depths for soil cement bank protection below drop structures should be deepened to account for the increased scour. Some typical sections of soil cement grade control structures are shown in Figure 2.5.

2.3 SPECIFICATIONS

In addition to application techniques, construction specifications are equally important to the use of soil cement for channel instability and scour countermeasures. Important design considerations for soil cement include: types of materials and equipment used, mix design and methods, handling, placing and curing techniques. The following list of specifications reflects guidance in the **Pima County Department of Transportation's guidelines** on applications and use of soil cement for Flood Control Projects.⁽⁸⁾

Portland Cement. Portland Cement shall comply with the latest Specifications for Portland Cement (ASTM 150, CSA A-5, or AASHTO M85) Type II.

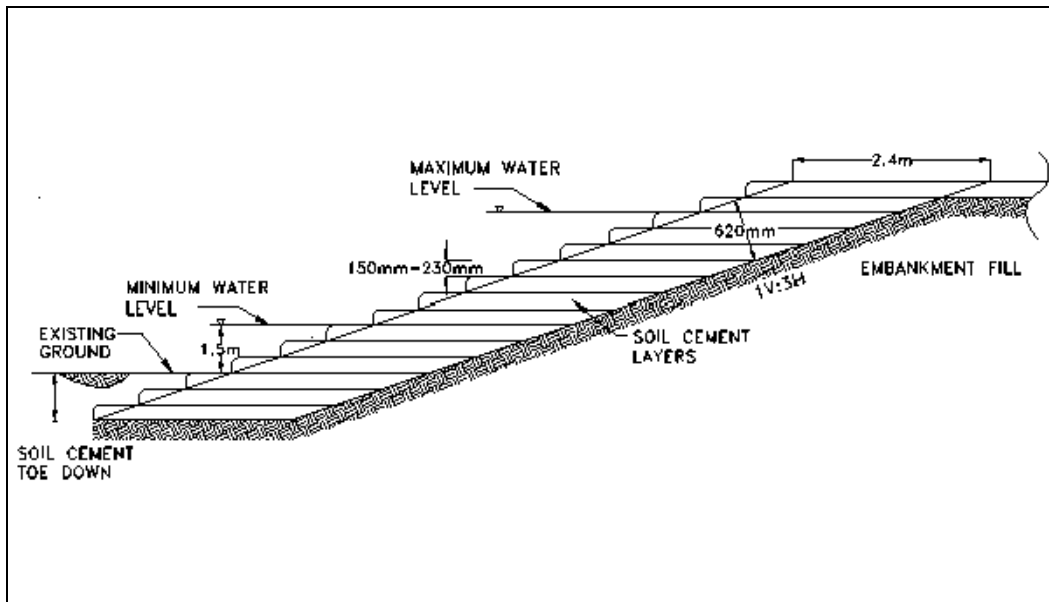

Figure 2.2. Typical section for soil cement slope protection (stair-step method).



Figure 2.3. Soil cement placed in the plating method parallel to the slope (PCA).

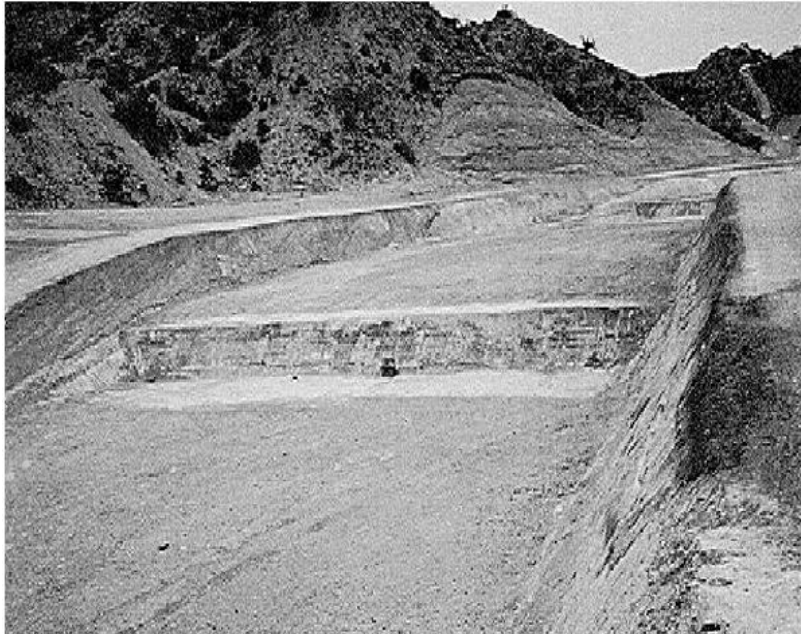

Figure 2.4. Soil cement bank protection and drop structures in Laughlin, NV.⁽⁷⁾

Fly Ash. The Portland Cement Association recommends that fly ash, when used, conform to ASTM Specification C-168.

Water. Water shall be clear and free from injurious amounts of oil, acid, alkali, organic matter or other deleterious substance.

Aggregate. The soil used in the soil cement mix shall not contain any material retained on a 38.1 mm (1-1/2-inch) sieve, nor any deleterious material. Soil for soil cement lining shall be obtained from the required excavations or from other borrow areas and stockpiled on the job site. The actual soil to be used shall be analyzed by laboratory tests in order to determine the job mix. The distribution and gradation of materials in the soil cement lining shall not result in lenses, pockets, streaks, or layers of material differing substantially in texture or gradation from surrounding material. Soil shall conform to the following gradation:

<u>Sieve Size</u>	<u>Percent Passing (Dry Weight)</u>
38.1 mm (1-1/2 in.)	98% - 100%
No. 4	60% - 90%
No. 200	5% - 15%

The Plasticity Index (PI) shall be a maximum of 3. Clays with a PI greater than 6 generally require a greater cement content and are more difficult to mix with cement.

Clay and silt lumps larger than 12.7 mm (1/2 inch) shall be unacceptable, and screening, in addition to that previously specified, shall be required whenever this type of material is encountered.

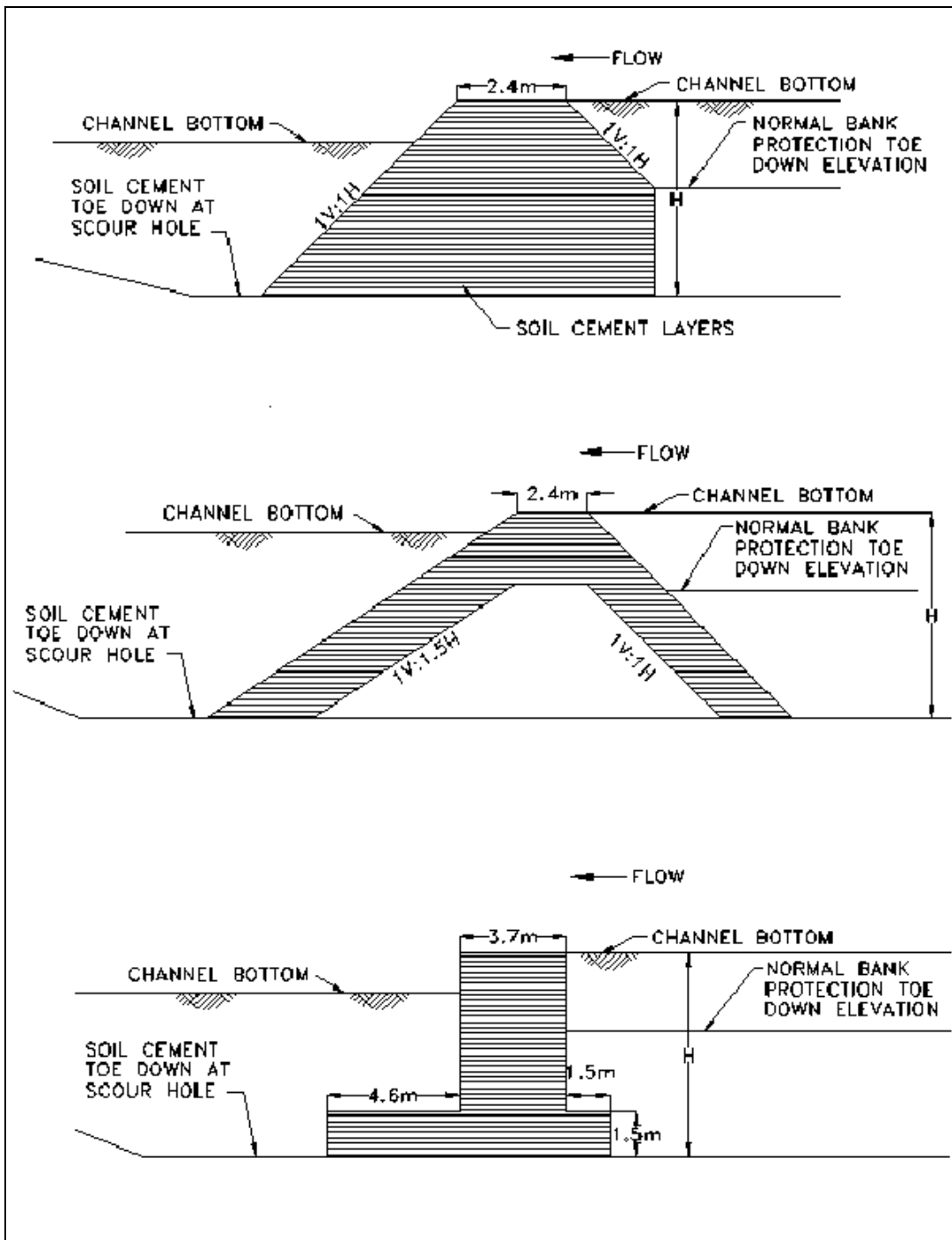

Figure 2.5. Typical sections for soil cement grade control structures (PCA).

Mix Design. The design requirements for the soil cement shall be such that it has a compressive strength of 5170 kPa (750 psi) at the end of 7 days unless otherwise specified. A 24-hour test shall be run to monitor the mix design on a daily basis. Experience has shown that 24-hour compressive strength results for moist cured samples are approximately 50 to 60 percent of the seven day strength (moist cured for six days and soaked in water for 24 hours). Once the design strength mix is determined, a 24-hour test shall be run using the mix to obtain a 24-hour compressive strength which will be used to monitor the daily output of the central plant. Seven (7) day samples shall also be taken for final acceptance. The amount of stabilizer thus determined by laboratory testing shall continue to be monitored throughout the life of the project with modifications as required for existing field conditions.

NOTE: The **stabilizer** is defined as the cementitious portion of the mix which may be composed of portland cement only or a mixture of portland cement and fly ash or other supplement.

The cementitious portion of the soil-cement mix shall consist of one of the following alternatives:

1. One hundred percent (100 percent) portland cement
2. Eighty five percent (85 percent) portland cement and fifteen percent (15 percent) fly ash by weight of stabilizer.

The ratio of replacement shall be one kilogram of fly ash to one kilogram of portland cement removed meaning one to one replacement by weight.

Mixing Method. Soil Cement shall be mixed in an approved central plant having a twin shaft continuous-flow or batch-type pugmill. The plant shall be equipped with screening, feeding and metering devices that will add the soil, cement, fly ash (if utilized), and water into the mixer in the specified quantities. Figure 2.6 illustrates a typical continuous flow mixing plant operation. In the production of the soil cement, the percent of cement content and the percent of the cement plus fly ash shall not vary by more than +/- 0.3 percent from the contents specified by the Engineer.

NOTE: Soil cement can also be mixed in place, although for most bank protection projects the central plant method is preferred.

Blending of Cement and Fly Ash. The blending procedure shall provide a uniform, thorough, and consistent blend of cement and fly ash. The blending method and operation shall be approved before soil cement production begins. In blending of the stabilizer, the percent of fly ash content shall not vary by more than +/- 0.50 percent of the specified content.

Scales are required at both the cement and fly ash feeds. An additional scale may also be required at the stabilizer feed.

Required Moisture. The moisture content of the mix shall be adjusted as needed to achieve the compressive strength and compaction requirements specified herein.

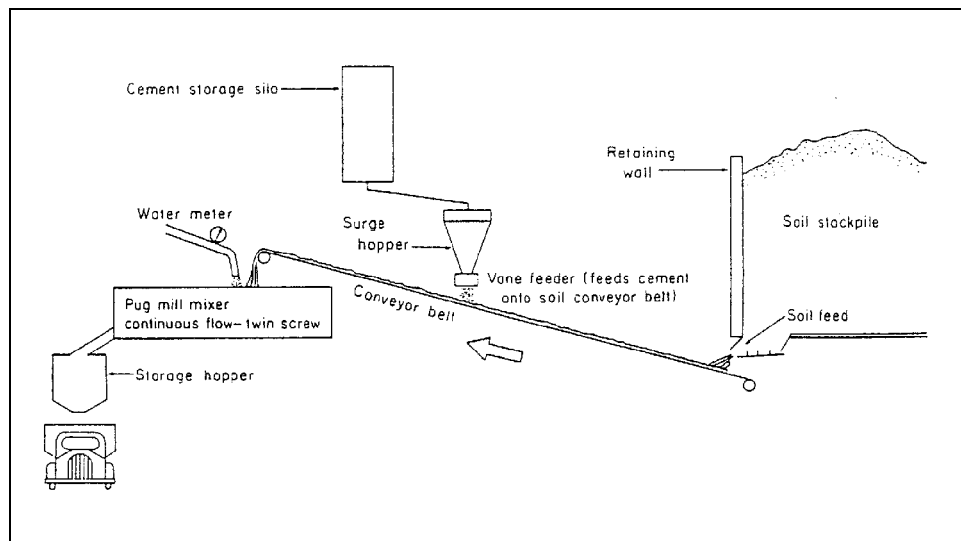

Figure 2.6. Schematic of continuous flow mixing plant for soil cement.⁽⁷⁾

Handling. The soil cement mixture shall be transported from the mixing area to the embankment in clean equipment provided with suitable protective devices in unfavorable weather. The total elapsed time between the addition of water to the mixture and the start of compaction shall be the minimum possible. In no case should the total elapsed time exceed thirty (30) minutes. This time may be reduced when the air temperature exceeds 32° C (90° F), or when there is a wind that promotes rapid drying of the soil cement mixture.

Placing. The mixture shall be placed on the moistened subgrade embankment, or previously completed soil cement, with spreading equipment that will produce layers of such width and thickness as are necessary for compaction to the required dimensions of the completed soil cement layers. The compacted layers of soil cement shall not exceed 200 mm (8 inches), nor be less than 100 mm (4 inches) in thickness. Each successive layer shall be placed as soon as practical after the preceding layer is completed and certified.

All soil cement surfaces that will be in contact with succeeding layers of soil cement shall be kept continuously moist by fog spraying until placement of the subsequent layer, provided that the contractor will not be required to keep such surfaces continuously moist for a period of seven days.

Mixing shall not proceed when the soil aggregate or the area on which the soil cement is to be placed is frozen. Soil cement shall not be mixed or placed when the air temperature is below 7° C (45° F), unless the air temperature is 5° C (40° F) and rising.

Compaction. Soil Cement shall be uniformly compacted to a minimum of 98 percent of maximum density as determined by field density tests. Wheel rolling with hauling equipment only is not an acceptable method of compaction.

At the start of compaction the mixture shall be in a uniform, loose condition throughout its full depth. Its moisture content shall be as specified in the section on Required Moisture (above). No section shall be left undisturbed for longer than 30 minutes during compaction operations. Compaction of each layer shall be done in such a manner as to produce a dense

surface, free of compaction planes, in not longer than one hour from the time water is added to the mixture. Whenever the operation is interrupted for more than two hours, the top surface of the completed layer, if smooth, shall be scarified to a depth of at least 24.5 mm (1 inch) with a spike tooth instrument prior to placement of the next lift. The surface after scarifying, shall be swept using a power broom or other method approved by the engineer to completely free the surface of all loose material prior to actual placement of the soil cement mixture for the next lift.

Finishing. After compaction, the soil cement shall be further shaped to the required lines, grades, and cross section and rolled to a reasonably smooth surface. Trimming and shaping of the soil cement shall be conducted daily at the completion of each day's production with a smooth blade.

Curing. Temporarily exposed surfaces shall be kept moist as set forth in the section on Placing (above). Care must be exercised to ensure that no curing material other than water is applied to the surfaces that will be in contact with succeeding layers. Permanently exposed surfaces shall be kept in a moist condition for seven days, or they may be covered with some suitable curing material, subject to the Engineer's approval. Any damage to the protective covering within seven days shall be repaired to satisfaction of the Engineer.

Regardless of the curing material used, the permanently exposed surfaces shall be kept moist until the protective cover is applied. Such protective cover is to be applied as soon as practical, with a maximum time limit of 24 hours between the finishing of the surface and the application of the protective cover or membrane. When necessary, the soil cement shall be protected from freezing for seven days after its construction by a covering of loose earth, straw or other suitable material approved by the Engineer.

Construction Joints. At the end of each day's work, or whenever construction operations are interrupted for more than two hours, a 15 percent minimum skew transverse construction joint shall be formed by cutting back into the completed work to form a full depth vertical face as directed by the Engineer.

2.4 REFERENCES

1. Pima County Department of Transportation Construction Specifications, Soil-Cement for Bank Protection, Linings and Grade Control Structures, Section 920, undated.
2. Portland Cement Association, 1984, "Soil Cement Slope Protection for Embankments: Construction," Report PCA, IS173.02W.
3. Portland Cement Association, 1984, "Soil Cement Slope Protection for Embankments: Field Inspection and Control," Report PCA, IS168.03W.
4. Portland Cement Association, 1986, "Soil Cement for Facing Slopes and Lining Channels, Reservoirs, and Lagoons," Report PCA, IS126.06W.
5. Portland Cement Association, 1986, "Suggested Specifications for Soil Cement Slope Protection for Earth Dams (Central Plant Mixing Method)," Report PCA, IS052W.
6. Portland Cement Association, 1991, "Oil Cement Slope Protection for Embankments: Planning and Design," Report PCA, IS173.03W.

7. Hansen, K.D. and J.B. Lynch, 1995, "Controlling Floods in the Desert with Soil-Cement," Authorized reprint from: Second CANMET/ACI International Symposium on Advances in Concrete Technology, Las Vegas, NV, June 11-14, 1995.
8. Sheilds, S.J., L.E. Maucher, A.A. Taji-Farouki, A. Osmolski, and D.A. Smutzer, 1988, Soil Cement Applications and Use in Pima County for Flood Control Projects, prepared for the Board of Supervisors/Board of Directors.

2.5 CONTACT

Schnabel Engineering Associates, Inc.
6880 South Yosemite Court, Suite 150
Englewood, Colorado 80112

(page intentionally left blank)

DESIGN GUIDELINE 3

WIRE ENCLOSED RIPRAP MATTRESS

(page intentionally left blank)

DESIGN GUIDELINE 3

WIRE ENCLOSED RIPRAP MATTRESS

3.1 INTRODUCTION

Wire enclosed riprap is commonly used in the state of New Mexico. The predecessor to this erosion control technique is known as rail bank protection and has been used in Arizona, Colorado and New Mexico since the 1970s. Wire enclosed riprap differs from gabions and gabion (Reno) mattresses in that it is a continuous framework rather than individual interconnected baskets. In addition, wire enclosed riprap is typically anchored to the embankment with steel stakes which are driven through the mattress. Construction of wire enclosed riprap is usually faster than gabions or gabion mattresses, and it also requires less wire mesh because internal junction panels are not used. Wire enclosed riprap is used primarily for slope protection. It has been used for bank protection, guide bank slope protection, and in conjunction with gabions placed at the toe of slope.

3.2 DESIGN GUIDELINES

Guidelines for the dimensions, placement, anchoring, splicing, and quantity formulas are shown on Figure 3.1. Design procedures for the selection of rock fill for wire enclosed riprap can be found in HEC-11,⁽¹⁾ Simons et al.⁽²⁾ and Maynard.⁽³⁾ Guidelines on selection and design of filter material can be found in HEC-11 and Holtz et al. (FHWA HI-95-038).⁽⁴⁾ The following guidelines and specifications reflect construction procedures for wire enclosed riprap recommended by the New Mexico State Highway and Transportation Department (NMSHTD).

1. Wire mesh fabric for riprap shall be hexagonal mesh or a "V" mesh meeting the requirements listed in the specifications.
2. Steel stakes may be railroad rails, not less than 14.9 kg/m (30 lb per yard), 102 mm (4 in.) O.D. standard strength galvanized steel pipe, or 102 mm X 102 mm X 9.5 mm (4" X 4" X 3/8") steel angles.
3. If length of slope is 4.6 m (15 ft) or less, only one row of steel stakes 610 mm (2 ft) from the top edge of the riprap will be required unless otherwise noted on the plans.
4. Dimensions of the thickness, top of slope and toe of slope extents, and total length of protection shall be designated on the bridge or roadway plans.
5. The wire enclosed riprap thickness is usually 300 mm (12 in) unless otherwise shown on the plans. Thickness is usually 460 mm (18 in) at bridges.
6. Longitudinal splices may be made with one lap of galvanized 9 gage tie wire, 9 gage hog rings or 11 1/2 gage galvanized hard drawn interlocking wire clips.
7. In general, a minimum of 0.6 m (2 ft) of freeboard above the design water surface elevation should be maintained.

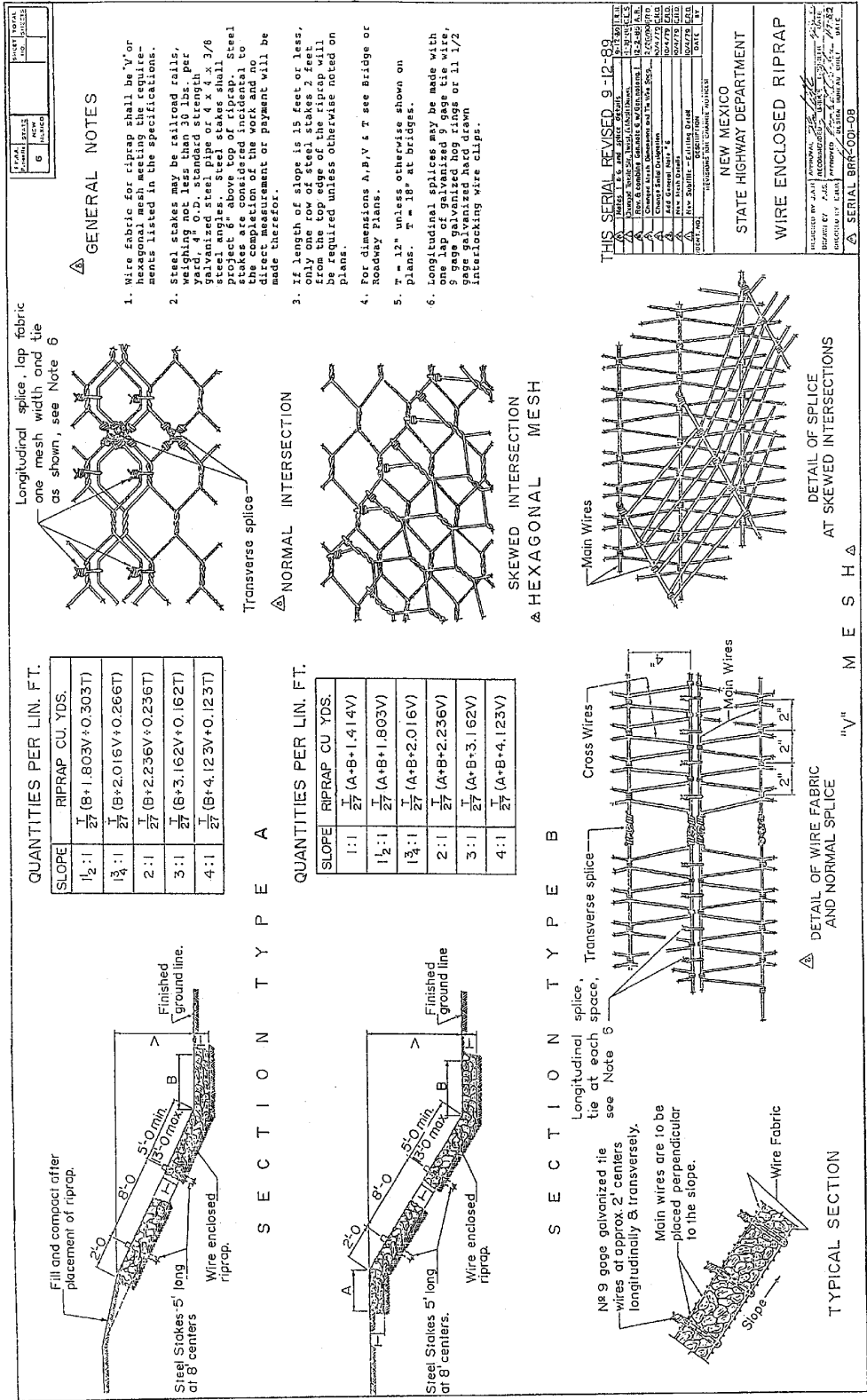

Figure 3.1. Wire enclosed riprap plans (NMSHTD).

3.3 SPECIFICATIONS

Wire Enclosed Riprap. Wire enclosed riprap shall consist of a layer of rock of the required thickness enclosed on all sides in wire fabric conforming with the details shown on the plans (Figure 3.1). The wire fabric shall be drawn tightly against the rock on all sides and tied with galvanized wire, locking clips, hog rings or connectors. When ties, locking clips, hog rings or connectors are used for tying mesh sections and selvages together, they shall be spaced 76 mm (3 inches) apart or less as shown on the plans. Galvanized wire ties shall be spaced approximately 610 mm (2 feet) on center and shall be anchored to the bottom layer of wire fabric, extended through the rock layer, and tied securely to the top layer of wire fabric. When indicated on the plans, wire enclosed riprap shall be anchored to the slopes by steel stakes driven through the riprap into the embankment. Stakes shall be spaced as indicated on the plans.

Filter. See HEC-11⁽¹⁾ and Holtz et al. (FHWA HI-95-038)⁽⁴⁾ for selection, design, and specifications of filter materials.

3.4 INSTALLATION EXAMPLE

A typical example of wire enclosed riprap installed by NMSHTD is shown in Figure 3.2. A side slope of a guide bank at the I-25 crossing of the Rio Galisteo protected with wire enclosed riprap is shown.



Figure 3.2. Wire enclosed riprap used for guide bank side slope protection at I-25 crossing of Rio Galisteo, New Mexico (NMSHTD).

3.5 REFERENCES

1. Brown, S.A. and E.S. Clyde, 1989, "Design of Riprap Revetment," Hydraulic Engineering Circular No. 11, FHWA-IP-016, prepared for FHWA, Washington, D.C.
2. Simons, D.B., Y.H. Chen, L.J. Swenson, and R. Li, 1984, "Hydraulic Tests to Develop Design Criteria for the Use of Reno Mattresses," Civil Engineering Department - Engineering Research Center, Colorado State University, Fort Collins, CO, *Report*.

3. Maynard, S.T., 1995, "Gabion Mattress Channel-Protection Design," Journal of Hydraulic Engineering, ASCE, Vol. 121,7, pp. 519 - 522.
4. Holtz, D.H., B.R. Christopher, and R.R. Berg, 1995, "Geosynthetic Design and Construction Guidelines," National Highway Institute, Publication No. FHWA HI-95-038, Federal Highway Administration, Washington D.C., May.

3.6 CONTACT

New Mexico State Highway and Transportation Department
P.O. Box 1149
Santa Fe, New Mexico 87504-1149

DESIGN GUIDELINE 4
ARTICULATED CONCRETE BLOCK SYSTEM

(page intentionally left blank)

DESIGN GUIDELINE 4

ARTICULATED CONCRETE BLOCK SYSTEM

4.1 INTRODUCTION

Articulated concrete block systems (ACB's) provide a flexible alternative to riprap, gabions and rigid revetments. These systems consist of preformed units which either interlock or are held together by steel rods or cables (Figure 4.1), or abut together to form a continuous blanket or mat. This design guideline considers two applications of ACB's: Application 1 - bankline and abutment revetment and bed armor; and Application 2 - pier scour protection.

There is little experience with the use of articulated block systems as a scour countermeasure for bridge piers alone. More frequently, these systems have been used for revetments and channel armoring where the mat is placed across the entire channel width and keyed into the abutments or bank protection. For this reason, guidelines for placing articulated block systems at banklines and channels are well documented, but there are few published guidelines on the installation of these systems around bridge piers. Where articulated block systems have been installed as a countermeasure for scour at bridge piers, cable-tied concrete mats have more often been used.

Specifications and design guidelines for installation and anchoring of ACB's are documented in HEC-11⁽¹⁾ and guidelines on the selection and design of filter material can be found in HEC-11 and Holtz et al. (FHWA HI-95-038)⁽²⁾. HEC-11 directs the designer to the manufacturer's literature for the selection of appropriate block sizes for a given hydraulic condition. Manufacturers of ACB's have a responsibility to test their products and to develop design criteria based on the results from these tests. Since ACB's vary in shape and performance from one proprietary system to the next, each system will have unique design criteria. A procedure to develop hydraulic design criteria for ACB's given the appropriate performance data for a particular block system is presented in this section.

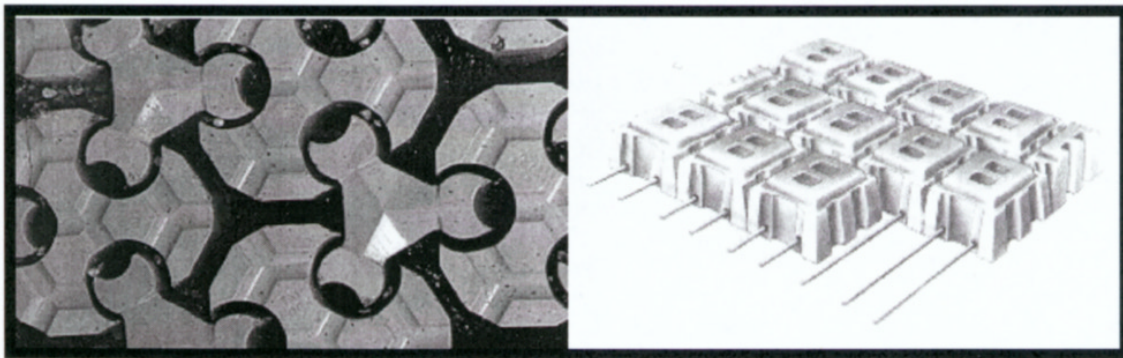

(a)

(b)

Figure 4.1. Examples of (a) interlocking block (courtesy American Excelsior) and (b) cable-tied block systems (courtesy Armortec).

4.2 BACKGROUND

Beginning in 1983, a group of agencies of the federal government, led by the Federal Highway Administration (FHWA), initiated a multi-year research and testing program in an effort to determine, quantitatively, the performance and reliability of commercially available erosion protection treatments. The research was concluded in July 1989, with the final two years of testing concentrating on the performance of ACB's. Testing methodologies and results for embankment overtopping conditions are published in Clopper and Chen⁽³⁾ and Clopper.^(4,5)

The tests provided both qualitative and quantitative insight into the hydraulic behavior of these types of revetments. The mechanisms contributing to the hydraulic instability of revetment linings were identified and quantitatively described as a result of this research effort. Threshold hydraulic loadings were related to forces causing instability in order to better define selection, design, and installation criteria. Concurrently with the FHWA tests, researchers in Great Britain were also evaluating similar erosion protection systems at full scale. Both groups of researchers agreed that an accurate, yet suitably conservative, definition of "failure" for articulated revetment systems can be described as the local loss of intimate contact between the revetment and the subgrade it protects. This loss of contact can result in the progressive growth of one or more of the following destabilizing processes:

1. Ingress of flow beneath the armor layer, causing increased uplift pressure and separation of blocks from subgrade.
2. Loss of subgrade soil through gradual piping erosion and/or washout.
3. Enhanced potential for rapid saturation and liquefaction of subgrade soils, causing shallow slip geotechnical failure (especially in silt-rich soils on steep slopes).
4. Loss of block or group of blocks from the revetment matrix, directly exposing the subgrade to the flow.

Therefore, selection, design, and installation considerations must be concerned, primarily, with maintaining intimate contact between the block system and the subgrade for the stress levels associated with the hydraulic conditions of the design event.

4.3 APPLICATION 1: HYDRAULIC DESIGN PROCEDURE FOR ACB's FOR REVETMENT OR BED ARMOR

The design procedure quantifies the hydraulic stability of revetment block systems using a "discrete particle" approach (like many riprap sizing methods). This approach is in contrast to the "continuum method" typically used for selecting blankets or vegetative linings. The design approach is similar to that introduced by Stevens⁽⁶⁾ to derive the "**factor of safety**" method of riprap design as described in HDS 6.⁽⁷⁾ The force balance has been recomputed considering the properties of concrete blocks, and the Shields relationship utilized in the HDS 6 approach to compute the critical shear stress has been replaced with actual test results. The design procedure incorporates results from hydraulic tests into a method which is based on fundamental principles of open channel flow and rigid body mechanics. The ratio of resisting to overturning moments (the "force balance" approach) is analyzed based on the size and weight characteristics of each class and type of block system and includes performance data from full-scale laboratory testing. This ratio is then used to determine the "**factor of safety**" against the initiation of uplift about the most critical axis of the block.

Considerations are also incorporated into the design procedure which can account for the additional forces generated on a block which protrudes above the surrounding matrix due to subgrade irregularities or imprecise placement. **Since finite movement constitutes "failure," as defined in the foregoing discussion, the analysis methodology purposely contains no explicit attempt to account for resistive forces due to cables or rods.** Similarly, the additional stability which may arise from vegetative root anchorage or mechanical anchoring devices, while recognized as significant, is ignored in the analysis procedures for the sake of conservatism in selection and design.

4.3.1 Selection of Factor of Safety

The designer must determine what factor of safety should be used for a particular design. Some variables which should affect the selection of the factor of safety used for final design are: risks associated with a failure of the project, the uncertainty of hydraulic values used in the design, and uncertainties associated with installation practices. Typically, a minimum factor of safety of 1.5 is used for revetment design when the project hydraulic conditions are well known and variations in the installation can be accounted for. Higher factors of safety are typically used for protection at bridge piers, abutments and at channel bends due to the complexity in computing shear stress at these locations. Research is being conducted to determine appropriate values for factors of safety at bridge piers and abutments.

4.3.2 Stability of a Single Concrete Block on a Sloping Surface

The stability of a single block on a sloping surface is a function of the magnitude and direction of stream velocity and shear stress, the depth of flow, the angle of the inclined surface on which it rests, geometric properties, and weight. Considering flow along a channel bank as shown on Figure 4.2, the forces acting on a concrete block are the lift force F_L , the drag force F_D , and the weight of the block, W_A . Block stability is determined by evaluating the moments about the point O about which rotation can take place. The components of forces relative to the plane of motion (assumed to act along the resultant force R) are shown in Figure 4.2.c. The relationship that defines the equilibrium of the block is:

$$\ell_2 W_A \cos \theta = \ell_1 W_A \sin \theta \cos \beta + \ell_3 F_D \cos \delta + \ell_4 F_L \quad (4.1)$$

where the symbols are shown in Figure 4.2 and described below:

W_A	=	Submerged weight of the block
ℓ_1 and ℓ_2	=	Moment arms of the weight of the block (side slope and longitudinal slope)
F_D	=	Drag force on the block
F_L	=	Lift force on the block
ℓ_3 and ℓ_4	=	Moment arms of the lift and drag forces on the block
θ	=	Side slope angle relative to the horizontal plane
λ	=	Angle between the horizontal and the velocity vector measured in the plane of the side slope. This derivation is valid for "horizontal condition" where $\lambda = \alpha$, where $\alpha =$ slope angle of a plane bed (i.e., uniform flow parallel to bed)
δ	=	Angle between the drag force and particle movement direction = $90 - \beta - \lambda$
β	=	Angle between the block movement direction and the vertical plane

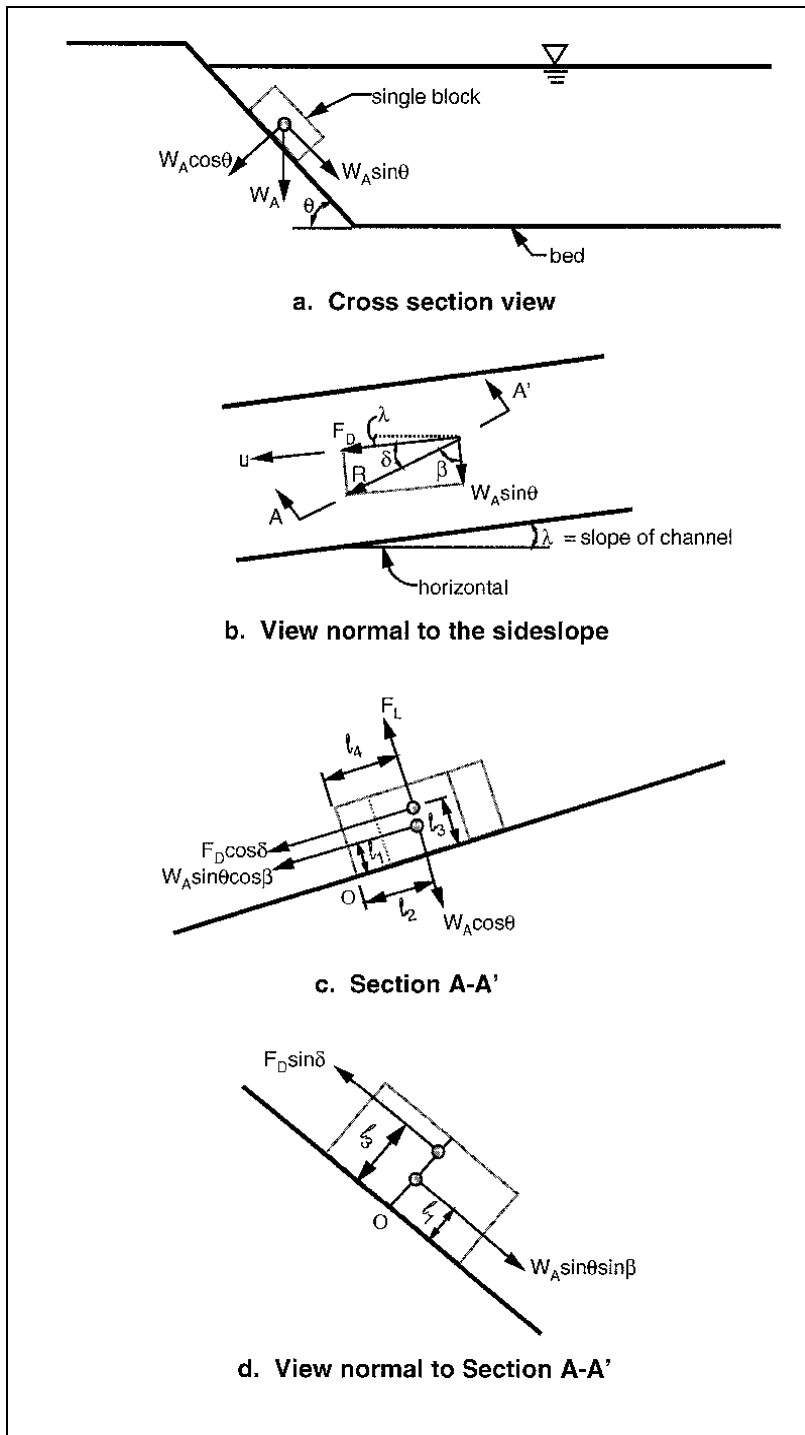

Figure 4.2. Forces acting on a single block resting on the side slope of a channel.

The factor of safety, SF, for the block can be defined as the ratio of moments resisting motion to those tending to rotate the block out of its resting position. Accordingly:

$$SF = \frac{l_2 W_A \cos \theta}{l_1 W_A \sin \theta \cos \beta + l_3 F_D \cos \delta + l_4 F_L} \quad (4.2)$$

rearranging and substituting terms gives the final form of the factor of safety equations:

$$SF = \frac{\cos \theta \left(\frac{l_2}{l_1} \right)}{\eta' \left(\frac{l_2}{l_1} \right) + \sin \theta \cos \beta} \quad (4.3)$$

$$\beta = \tan^{-1} \left[\frac{\cos \lambda}{\left(\frac{M}{N} + 1 \right) \left(\frac{l_1}{l_2} \right) \sin \theta + \sin \lambda} \right] \quad (4.4)$$

where:

$$\frac{M}{N} = \frac{l_4 F_L}{l_2 F_D} \quad (4.5)$$

The stability number, η is defined as:

$$\eta = \frac{\tau_o}{\tau_c} \quad (4.6)$$

where:

- τ_o = Shear stress or tractive force acting on the channel boundaries and can be computed from design hydraulic conditions [Pa (lb/ft²)]
- τ_c = Critical shear stress when "failure" occurs [Pa (lb/ft²)]

The stability number on a side slope, η' , is defined as:

$$\eta' = \left\{ \frac{\frac{M}{N} + \sin(\lambda + \beta)}{\frac{M}{N} + 1} \right\} \eta \quad (4.7)$$

The above equations can be solved by knowing τ_o and τ_c and the angles θ and λ , and assuming the ratios l_1/l_2 , l_3/l_4 and F_L/F_D .

Incipient motion analysis identifies τ_c as the loading which causes a single particle to begin to move. Critical shear stress for sediments can be estimated based on particle size diameter from relationships such as the Shields equation. Extensive research has been conducted for incipient motion analysis of sediments and larger sized rocks. However, there are limited test data on the performance of proprietary products such as ACB's. Therefore, hydraulic testing of ACB's must be conducted before a complete design procedure can be developed. Several manufacturers have performed these tests for their products. The hydraulic tests allow sizing and design criteria to be developed from the data generated. Using the procedure discussed above with hydraulic testing, a design methodology can be established for almost any size or shape of block.

4.3.3 Consideration of Additional Forces Due to Projecting Blocks

While charts have been developed to aid in the design of ACB systems, the charts generally are based on the assumption of a "perfect" installation (i.e., no projecting of individual blocks into the flow). Some installation tolerance must be anticipated and the factor of safety equation modified to account for projections (Figure 4.3). Because installation out of the design tolerance could greatly reduce the factor of safety and lead to failure, construction inspection becomes critical to successful performance of ACB systems.

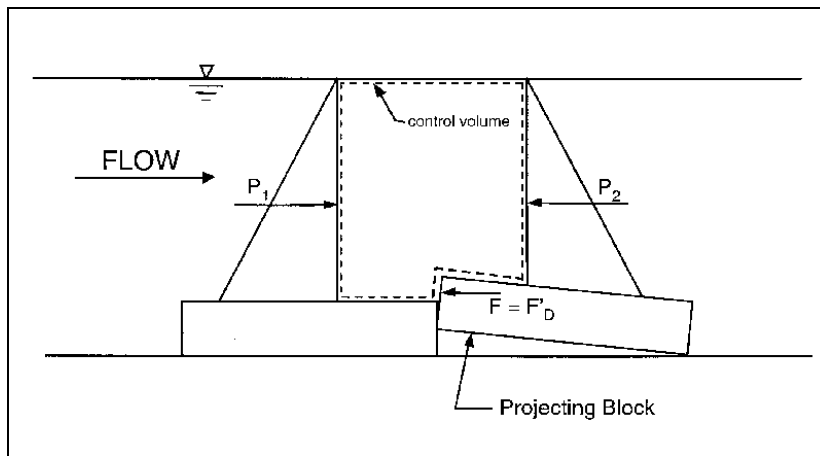

Figure 4.3. Control Volume for computing horizontal force on a projecting block.

When the additional forces of projecting blocks are considered (Figure 4.3) the factor of safety equation becomes:

$$SF = \frac{\cos \theta \left(\frac{l_2}{l_1} \right)}{\eta' \left(\frac{l_2}{l_1} \right) + \sin \theta \cos \beta + \frac{l_3 F'_D \cos \delta + l_4 F'_L}{l_1 W_A}} \quad (4.8)$$

where F'_D and F'_L are the additional lift and drag forces caused by the projecting block.

Numerical tests indicate that it is sufficiently accurate to compute the drag force on the block in the following manner:

$$F'_D = C(\Delta Z \omega \rho V^2) \quad (4.9)$$

where:

- F'_D = Drag force, N (lb)
- ΔZ = Projection height, m (ft)
- ω = Width of projection, m (ft)
- C = Momentum transfer coefficient assumed equal to 0.5
- ρ = Fluid density, Kg/m³ (Slugs/ft³)
- V = Velocity, m/s (ft/s)

4.3.4 Factor of Safety Method Design Example (SI)

The following example illustrates the use of the factor of safety method in the selection of block sizes for ACB's for revetment or bed armor. Two generic block sizes are used to illustrate the use of design charts and the factor of safety equations. Design examples using design charts similar to those which would be provided by a block manufacturer and using the factor of safety equations, directly, are presented. The examples assume that hydraulic testing has been performed for the block system to quantify a critical shear stress and to develop the design charts.

Given:

A trapezoidal channel with a bed slope of 0.039 m/m, side slopes 1V:2.5H, and the following hydraulic conditions:

<u>Block Size 1</u>	<u>Block Size 2</u>
n = 0.032	n = 0.026
Maximum Depth = 0.616 m	Maximum Depth = 0.549 m
Average Velocity = 3.78 m/s	Average Velocity = 4.36 m/s
Bed Shear, $\tau_o = 235.2$ Pa	Bed Shear, $\tau_o = 209.8$ Pa

Block Size 1 has a greater open area and therefore yields a higher Manning's n value.

Design Chart Example

Design charts can be developed from the factor of safety method given block properties and hydraulic test results. These are normally developed by the ACB manufacturer for use by the design engineer. Typically these curves relate the allowable shear stress or velocity to channel bed slope for a given factor of safety as shown in Figure 4.4. This chart represents the stability of the ACB's placed flat on the channel bed neglecting the influence of the side slope. Charts which account for the effect of channel side slope on the factor of safety are also provided by the manufacturer (Figure 4.5). The factor of safety can then be computed by taking the ratio of the allowable shear stress or velocity to the design conditions as follows:

$$SF = \frac{\tau_a}{\tau_o} (SF_a) K_1 \quad \text{or} \quad SF = \frac{V_a}{V_o} (SF_a) K_1 \quad (4.10)$$

where:

- τ_a and V_a = Allowable shear stress and velocity for the factor of safety for which the chart was developed (SF_a)
- τ_c and V_c = Are synonymous to critical shear stress and velocity for a factor of safety of one
- τ_o and V_o = Design shear stress and velocity
- K_1 = Side slope correction factor

Step 1: Determine the allowable shear stress for the hydraulic conditions

From Figure 4.4 the allowable shear stress for the ACB's on a bed slope of 3.9% with a factor of safety of one is:

$\tau_a = 945 \text{ Pa}$ (allowable shear stress for Block Size 1)

$\tau_a = 1085 \text{ Pa}$ (allowable shear stress for Block Size 2)

Step 2: Determine the side slope correction factor, K_1 :

From Figure 4.5 the reduction factor for a 1V:2.5H side slope is:

$K_1 = 0.73$ (for Block Size 1)

$K_1 = 0.67$ (for Block Size 2)

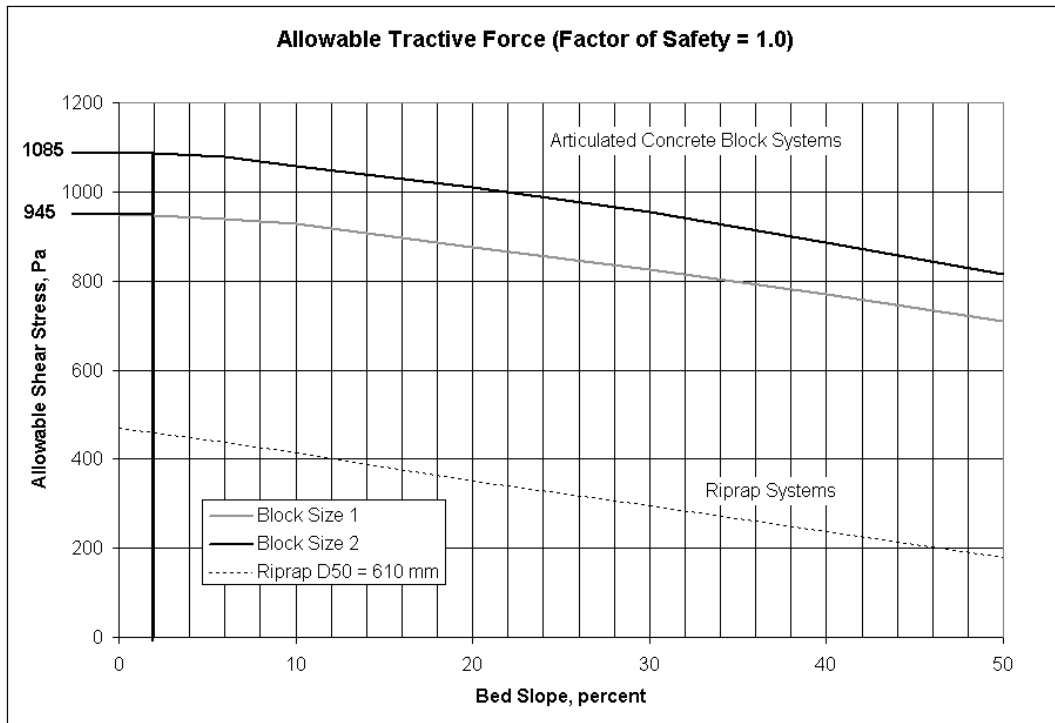

Figure 4.4. Plot of allowable shear stress vs. bed slope (SI).

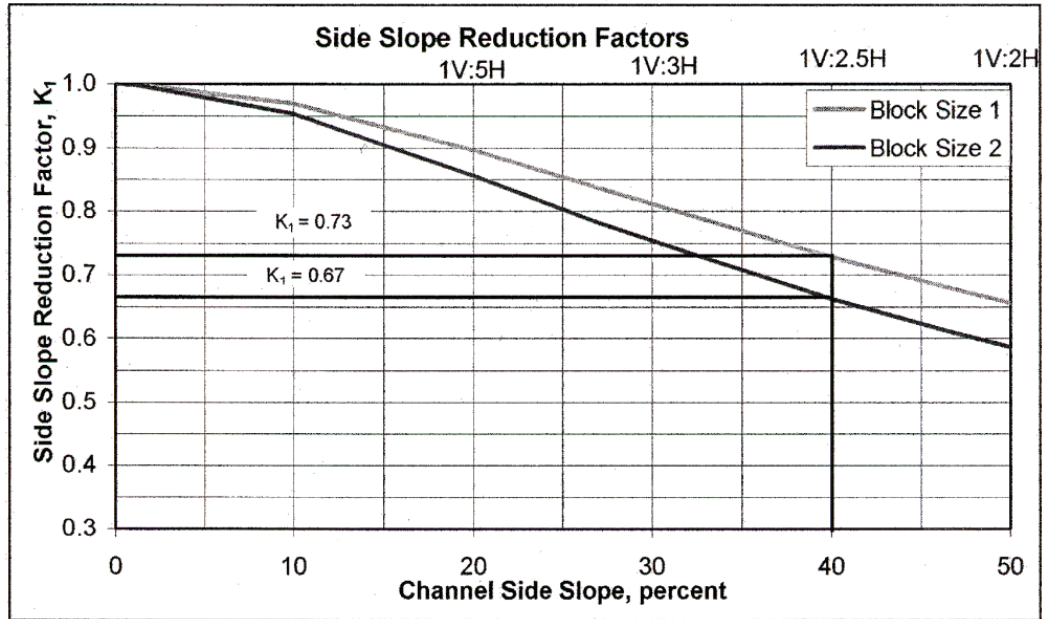

Figure 4.5. Plot of side slope reduction factors.

Step 3: Determine the factor of safety for blocks placed on the channel side slope:

$$SF + \frac{\tau_a}{\tau_o} (SF_a) K_1 = \frac{945}{235.2} (1) 0.73 = 2.9 \quad (\text{for Block Size 1})$$

$$SF = \frac{\tau_a}{\tau_o} (SF_a) K_1 = \frac{1085}{209.8} (1) 0.67 = 3.5 \quad (\text{for Block Size 2})$$

Factor of Safety Equations Example

Given: In addition to the hydraulic conditions given above, the following block characteristics are provided.

Block Size	Submerged Weight (N)	l_1 (mm)	l_2 (mm)	l_3 (mm)	l_4 (mm)	ΔZ (mm)	ω (mm)	τ_c^* Pa (N/m ²)
1	127	76	223	122	223	12.7	329	958.0
2	148	76	223	122	223	12.7	329	1102.0

* τ_c determined from testing.

Step 1: Compute factor of safety parameters

If H = horizontal component of side slope angle:

$$\theta = \tan^{-1}\left(\frac{V}{H}\right) = \tan^{-1}\left(\frac{1}{2.5}\right) = 21.8^\circ \quad (\text{side slope angle})$$

If S = bed slope:

$$\lambda = \tan^{-1}\left(\frac{S}{I}\right) = \tan^{-1}\left(\frac{0.039}{1}\right) = 2.23^\circ \quad (\text{bed slope angle})$$

$$\eta = \frac{\tau_o}{\tau_c} = \left(\frac{235.2}{958}\right) = 0.246 \quad (\text{stability number for Block Size 1})$$

$$\eta = \frac{\tau_o}{\tau_c} = \left(\frac{209.8}{1102}\right) = 0.190 \quad (\text{stability number for Block Size 2})$$

conservatively assuming that $F_L = F_D$ then:

$$\frac{M}{N} = \frac{\ell_4 F_L}{\ell_3 F_D} = \frac{223}{122} = 1.83$$

$$\beta = \tan^{-1} \frac{\cos(2.23)}{\left(\frac{1.83 + 1}{\eta}\right) \left(\frac{76}{223}\right) \sin(21.8) + \sin(2.23)}$$

$$\beta = 33.63^\circ \quad (\text{for Block Size 1})$$

$$\beta = 27.33^\circ \quad (\text{for Block Size 2})$$

$$\delta = 90 - \beta - \lambda$$

$$\delta = 54.14^\circ \quad (\text{for Block Size 1})$$

$$\delta = 60.44^\circ \quad (\text{for Block Size 2})$$

$$\eta' = 0.210 \quad (\text{stability number on the side slope for Block Size 1})$$

$$\eta' = 0.156 \quad (\text{stability number on the side slope for Block Size 2})$$

Step 2: Compute Factor of Safety

$$SF = \frac{\cos(21.8^\circ) \left(\frac{223}{76}\right)}{0.210 \left(\frac{223}{76}\right) + \sin(21.8^\circ) \cos(33.63^\circ)} = 2.94 \quad (\text{for block size 1})$$

$$SF = \frac{\cos(21.8^\circ) \left(\frac{223}{76}\right)}{0.156 \left(\frac{223}{76}\right) + \sin(21.8^\circ) \cos(27.33^\circ)} = 3.46 \quad (\text{for block size 2})$$

Step 3: Consider Effects of Possible Vertical Projections

It is assumed that an installation specification tolerance of 12.7 mm in the vertical will be maintained. Using Equation 4.9:

$$F'_D = 0.5(0.0127)(0.329)(1000)(V)^2 = 2.089V^2$$

$$F'_D = 2.089(3.78)^2 = 29.8 \quad \text{for Block Size 1}$$

$$F'_D = 2.089(4.36)^2 = 39.7 \quad \text{for Block Size 2}$$

Now assuming that the additional lift due to the vertical displacement is equal to the additional drag (that is $F'_D = F'_L$):

For Block Size 1:

$$SF = \frac{\cos(21.8^\circ) \left(\frac{223}{76} \right)}{0.210 \left(\frac{223}{76} \right) + \sin(21.8^\circ) \cos(33.63^\circ) + \frac{122(29.8) \cos(54.14^\circ) + 223(29.8)}{76(127)}} = 1.48$$

For Block Size 2:

$$SF = \frac{\cos(21.8^\circ) \left(\frac{223}{76} \right)}{0.156 \left(\frac{223}{76} \right) + \sin(21.8^\circ) \cos(27.33^\circ) + \frac{122(39.7) \cos(60.44^\circ) + 223(39.7)}{76(148)}} = 1.53$$

Block Size 1 exhibits a factor of safety slightly less than the minimum value of 1.50.

Recommend Block Size 2

It can be seen that the consideration of projecting blocks has a significant effect on the factor of safety. In this example, a projection of 12.7 mm resulted in a reduction in the factor of safety by approximately a factor of 2. If the effect of projecting blocks is not considered in the development of design charts or the factor of safety equations, then increasing the factor of safety used for final design may be appropriate. **Construction observation/inspection to ensure that blocks are installed within the design tolerance is essential to successful performance of ACB systems.**

4.3.5 Factor of Safety Method Design Example (English)

The following example illustrates the use of the factor of safety method in the selection of block sizes for ACB's for revetment or bed armor. Two generic block sizes are used to illustrate the use of design charts and the factor of safety equations. Design examples using design charts similar to those which would be provided by a block manufacturer and using the factor of safety equations, directly, are presented. The examples assume that hydraulic testing has been performed for the block system to quantify a critical shear stress and to develop the design charts.

Given:

A trapezoidal channel with a bed slope of 0.039 ft/ft, side slopes 1V:2.5H, and the following hydraulic conditions:

<u>Block Size 1</u>	<u>Block Size 2</u>
n = 0.032	n = 0.026
Maximum Depth = 2.02 ft	Maximum Depth = 1.80 ft
Average Velocity = 12.4 ft/s	Average Velocity = 14.3 ft/s
Bed Shear, $\tau_o = 4.9 \text{ lb/ft}^2$	Bed Shear, $\tau_o = 4.4 \text{ lb/ft}^2$

Block Size 1 has a greater open area and therefore yields a higher Manning's n value.

Design Chart Example

Design charts can be developed from the factor of safety method given block properties and hydraulic test results. These are normally developed by the ACB manufacturer for use by the design engineer. Typically these curves relate the allowable shear stress or velocity to channel bed slope for a given factor of safety as shown in Figure 4.6. This chart represents the stability of the ACB's placed flat on the channel bed neglecting the influence of the side slope. Charts which account for the effect of channel side slope on the factor of safety are also provided by the manufacturer (Figure 4.7). The factor of safety can then be computed by taking the ratio of the allowable shear stress or velocity to the design conditions as follows:

$$SF = \frac{\tau_a}{\tau_o} (SF_a) K_1 \quad \text{or} \quad SF = \frac{V_a}{V_o} (SF_a) K_1 \quad (4.10)$$

where:

- τ_a and V_a = Allowable shear stress and velocity for the factor of safety for which the chart was developed (SF_a)
- τ_a and V_a = Are synonymous to critical shear stress and velocity for a factor of safety of one
- τ_o and V_o = Design shear stress and velocity
- K_1 = Side slope correction factor

Step 1: Determine the allowable shear stress for the hydraulic conditions

From Figure 4.6 the allowable shear stress for the ACB's on a bed slope of 3.9% with a factor of safety of one is:

$$\tau_a = 19.7 \text{ lb/ft}^2 \quad (\text{allowable shear stress for Block Size 1})$$

$$\tau_a = 22.7 \text{ lb/ft}^2 \quad (\text{allowable shear stress for Block Size 2})$$

Step 2: Determine the side slope correction factor, K_1

From Figure 4.7 the reduction factor for a 1V:2.5H side slope is:

$$K_1 = 0.73 \quad (\text{for Block Size 1})$$

$$K_1 = 0.67 \quad (\text{for Block Size 2})$$

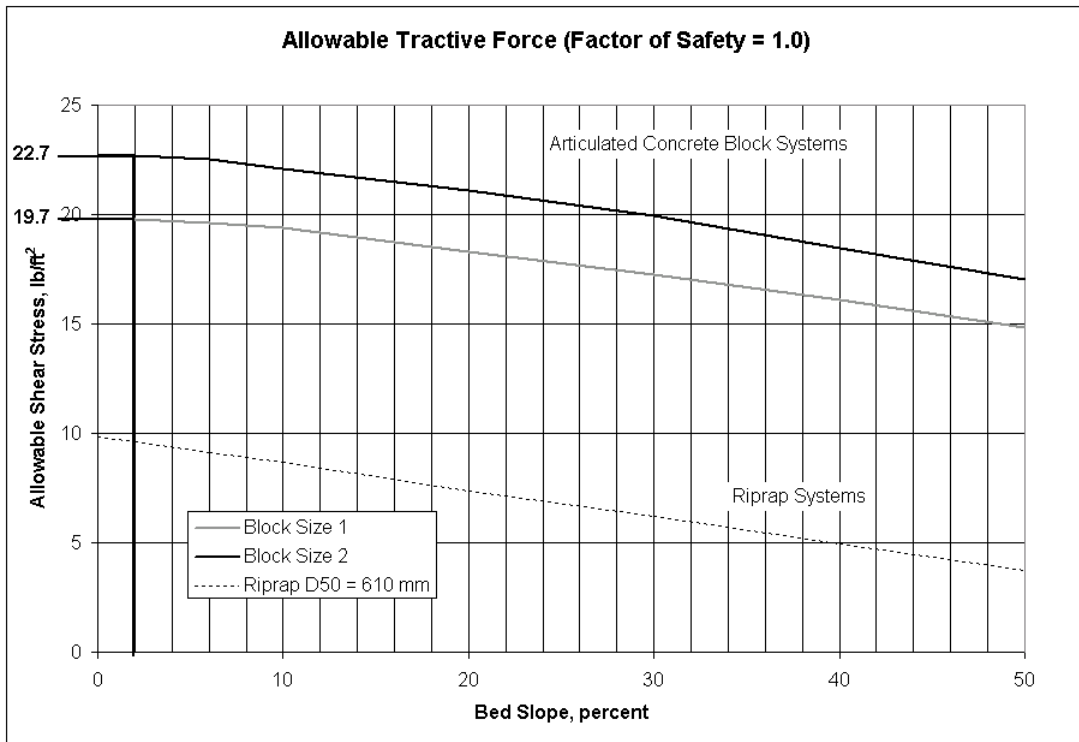

Figure 4.6. Plot of allowable shear stress vs. bed slope (English).

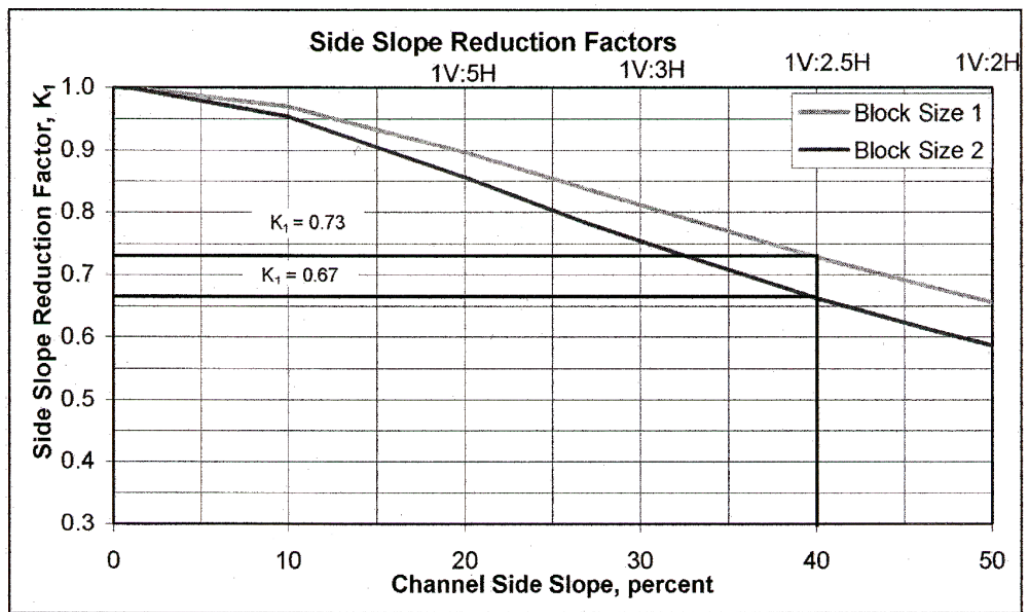

Figure 4.7. Plot of side slope reduction factors.

Step 3: Determine the factor of safety for blocks placed on the channel side slope:

$$SF + \frac{\tau_a}{\tau_o}(SF_a)K_1 = \frac{19.7}{4.9}(1)0.73 = 2.9 \quad (\text{for Block Size 1})$$

$$SF = \frac{\tau_a}{\tau_o}(SF_a)K_1 = \frac{22.7}{4.4}(1)0.67 = 3.5 \quad (\text{for Block Size 2})$$

Factor of Safety Equations Example

Given: In addition to the hydraulic conditions given above, the following block characteristics are provided.

Block Size	Submerged Weight (lb)	l_1 (in.)	l_2 (in.)	l_3 (in.)	l_4 (in.)	ΔZ (in.)	ω (in.)	τ_c^* (lb/ft ²)
1	28.6	3	8.8	4.8	8.8	0.5	13	20.0
2	33.3	3	8.8	4.8	8.8	0.5	13	23.0

* τ_c determined from testing.

Step 1: Compute factor of safety parameters

If H = horizontal component of side slope angle:

$$\theta = \tan^{-1}\left(\frac{V}{H}\right) = \tan^{-1}\left(\frac{1}{2.5}\right) = 21.8^\circ \quad (\text{side slope angle})$$

If S = bed slope:

$$\lambda = \tan^{-1}\left(\frac{S}{1}\right) = \tan^{-1}\left(\frac{0.039}{1}\right) = 2.23^\circ \quad (\text{bed slope angle})$$

$$\eta = \frac{\tau_o}{\tau_c} = \left(\frac{4.9}{20.0}\right) = 0.245 \quad (\text{stability number for Block Size 1})$$

$$\eta = \frac{\tau_o}{\tau_c} = \left(\frac{4.4}{23.0}\right) = 0.191 \quad (\text{stability number for Block Size 2})$$

conservatively assuming that $F_L = F_D$ then:

$$\frac{M}{N} = \frac{l_4 F_L}{l_3 F_D} = \frac{8.8}{4.8} = 1.83$$

$$\beta = \tan^{-1} \frac{\cos(2.23)}{\left(\frac{1.83 + 1}{\eta}\right) \left(\frac{3.0}{8.8}\right) \sin(21.8) + \sin(2.23)}$$

$$\beta = 33.65^\circ \quad (\text{for Block Size 1})$$

$$\beta = 27.56^\circ \quad (\text{for Block Size 2})$$

$$\delta = 90 - \beta - \lambda$$

$$\delta = 54.12^\circ \quad (\text{for Block Size 1})$$

$$\delta = 60.21^\circ \quad (\text{for Block Size 2})$$

$$\eta' = 0.209 \quad (\text{stability number on the side slope for Block Size 1})$$

$$\eta' = 0.157 \quad (\text{stability number on the side slope for Block Size 2})$$

Step 2: Compute Factor of Safety

$$SF = \frac{\cos(21.8^\circ) \left(\frac{8.8}{3.0}\right)}{0.209 \left(\frac{8.8}{3.0}\right) + \sin(21.8^\circ) \cos(27.56^\circ)} = 2.95 \quad (\text{for block size 1})$$

$$SF = \frac{\cos(21.8^\circ) \left(\frac{8.8}{3.0}\right)}{0.157 \left(\frac{8.8}{3.0}\right) + \sin(21.8^\circ) \cos(27.56^\circ)} = 3.45 \quad (\text{for block size 2})$$

Step 3: Consider Effects of Possible Vertical Projections

It is assumed that an installation specification tolerance of 0.5 inches in the vertical will be maintained. Using Equation 4.9:

$$F'_D = 0.5(0.0417)(1.083)(1.94)(V)^2 = 0.044V^2$$

$$F'_D = 0.044(12.4)^2 = 6.7 \quad \text{for Block Size 1}$$

$$F'_D = 0.044(14.3)^2 = 9.0 \quad \text{for Block Size 2}$$

Now assuming that the additional lift due to the vertical displacement is equal to the additional drag (that is $F'_D = F'_L$):

For Block Size 1:

$$SF = \frac{\cos(21.8^\circ) \left(\frac{8.8}{3.0}\right)}{0.209 \left(\frac{8.8}{3.0}\right) + \sin(21.8^\circ) \cos(33.65^\circ) + \frac{4.8(6.7) \cos(54.12^\circ) + 8.8(6.7)}{3.0(28.6)}} = 1.49$$

For Block Size 2:

$$SF = \frac{\cos(21.8^\circ) \left(\frac{8.8}{3.0} \right)}{0.157 \left(\frac{8.8}{3.0} \right) + \sin(21.8^\circ) \cos(27.56^\circ) + \frac{4.8(9.0) \cos(60.21^\circ) + 8.8(9.0)}{3.0(33.3)}} = 1.52$$

Block Size 1 exhibits a factor of safety slightly less than the minimum value of 1.50.

Recommend Block Size 2

It can be seen that the consideration of projecting blocks has a significant effect on the factor of safety. In this example, a projection of 0.5 inch resulted in a reduction in the factor of safety by approximately a factor of 2. If the effect of projecting blocks is not considered in the development of design charts or the factor of safety equations, then increasing the factor of safety used for final design may be appropriate. **Construction observation/ inspection to ensure that blocks are installed within the design tolerance is essential to the successful performance of ACB systems.**

4.4 APPLICATION 2: DESIGN GUIDELINES FOR ACB's FOR PIER SCOUR

4.4.1 Laboratory Studies

The hydraulic stability of articulated block systems at bridge piers can be assessed using the factor of safety method as previously discussed. However, uncertainties in the hydraulic conditions around bridge piers warrant increasing the factor of safety in lieu of a more rigorous hydraulic analysis. Experience and judgment are required when quantifying the factor of safety to be used for scour protection at an obstruction in the flow. In addition, when both contraction scour and pier scour are expected, design considerations for a pier mat become more complex. The following guidelines reflect guidance from McCorquodale,⁽⁸⁾ Minnesota Department of Transportation (MnDOT), and the Maine Department of Transportation (MDOT) for application of ACB's as a countermeasure for pier scour.

Hydraulic model studies were conducted for cable-tied articulated block systems at the University of Windsor, Canada⁽⁸⁾. Laboratory testing gave rise to a method of quantifying the suggested revetment extent around circular bridge piers as shown in Figure 4.8.

The pier scour protection dimensions shown in Figure 4.8 are defined by:

Width of the scour protection mat,	$WS = 2.5Y_s + D$
Upstream extent of scour protection,	$X1 = 1.25 Y_s$
Downstream extent of scour protection,	$X2 = 3 Y_s$
Estimated unprotected scour depth, Y_s , (using the CSU pier scour equation)	$Y_s = (2 * K_1 * K_2 * K_3 * (Y_1/a)^{0.35} * Fr^{0.43}) * a$

These dimensions are intended to reduce the amount of material required as compared to a rectangular mat. The concept is based on observations of greater pier scour occurring at the upstream end of a pier. The extent of protection at the upstream end of the pier is wider than the extent at the downstream end of the pier. Actual field applications of articulated block systems for pier protection have been installed as rectangular mats. **The technique illustrated in Figure 4.8 has not been applied in the field.**

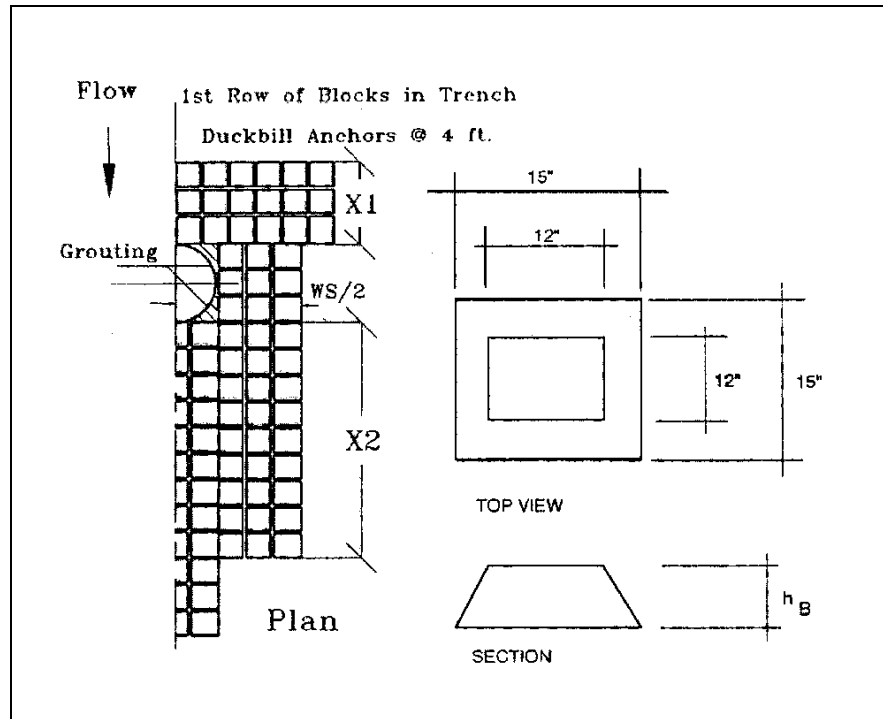

Figure 4.8. Suggested cable-tied mat dimensions for scour protection around circular bridge piers (after McCorquodale).⁽⁹⁾

National Cooperative Highway Research Program (NCHRP) Project 24-7, "Countermeasures to Protect Bridge Piers from Scour," was completed in December 1998.^(10, 11) This project evaluated alternatives to standard riprap installations as pier scour countermeasures. Two kinds of countermeasures were examined: flow altering countermeasures such as sacrificial piles and armoring countermeasures such as mattresses of cable tied blocks. None of the flow altering countermeasures were found to be overly effective. Based on laboratory testing, this study concluded that a countermeasure that provides "excellent protection" is a mattress of cable tied blocks underlain by a geotextile tied to the pier.⁽¹¹⁾ Design suggestions for a number of armoring countermeasures, including cable tied block are provided in a User's Guide.⁽¹⁰⁾

4.4.2 Guidelines for Seal Around Pier

An observed key point of failure for articulated block systems at bridge piers occurs at the seal where the mat meets the bridge pier.^(8,11) During the flume studies at the University of Windsor, the mat was grouted to the pier to prevent scouring of the sediments adjacent to the pier. This procedure worked successfully in the laboratory, but there are implications which must be considered when using this technique in the field. The transfer of moments from the mat to the pier may affect the structural stability of the pier. When the mat is attached to the pier the increased loadings on the pier must be investigated.

The State of Minnesota Department of Transportation (MnDOT) has installed a cable-tied mat for a pier at TH 32 over Clearwater River at Red Lake Falls. MnDOT recommends the use of tension anchors in addition to grout around the pier seal. Anchors can provide additional support for the mat and grout at the pier seal will reduce scouring underneath the mat. MnDOT provided the following specifications:

Anchors:

Use Duckbill anchors, 0.9 - 1.2 m (3 - 4 ft) deep. Use Duckbill anchors at corners and about every 2.4 m (8 ft) around pier footings.

Seal around Pier:

Research conducted by the FHWA has indicated that the space between the pier and the cable-tied concrete blocks must be filled or scour may occur under the blocks. To provide this seal, MnDOT proposed that concrete be placed around the pier. MnDOT suggested that the river bed could be excavated around the piers to the top of the footing. The mat could be put directly on top of the footing and next to the pier with concrete placed underneath, on top of, or both, to provide a seal between mat and pier.

The State of Maine Department of Transportation (MDOT) has designed an articulated block system for a pier at Tukey's Bridge over Back Cove. MDOT recommended a design in which grout bags were placed on top of the mat at the pier location to provide the necessary seal (Figure 4.9).

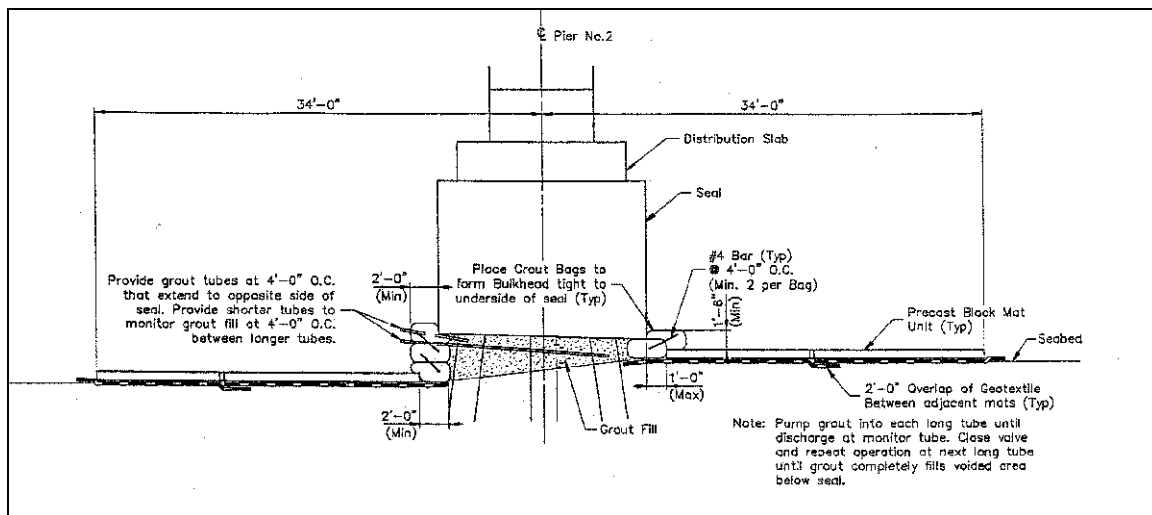

Figure 4.9. Design plans of cable-tied precast block mat for Tukey's Bridge, ME (MDOT).

In a 1998 review of European practice for bridge scour countermeasures,⁽¹²⁾ two approaches were identified for solving the problem of providing a seal between the bridge pier and articulating block or grout filled mattress systems. In Germany, reference was made to a proprietary system for installing a collar and tying the geotextile filter underlying a mattress to the bridge pier using a pneumatic tie (Figure 4.10). This approach appears feasible for circular piers. Considering possible settlement of the mattress relative to the structure (pile), a steel sleeve and a "top hat" of filter fabric were proposed with a collar of fabric laid on top of the mattress and tied to the sleeve as indicated in Figure 4.10. As relative settlement occurs, the sleeve is expected to slide down the pile and the top hat to expand, bellow fashion, with a collar for protection. This approach may be limited in areas where the top hat could be damaged by abrasion.

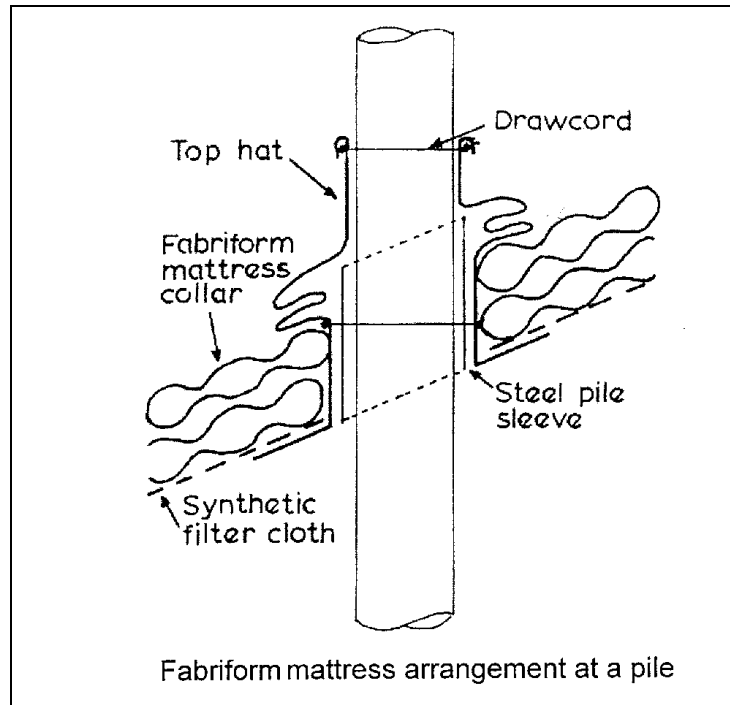

Figure 4.10. Flexible collar arrangement at a pile to seal the joint with a mattress.⁽¹²⁾

In the Netherlands, the recommended approach to the problem of sealing the joint between a mattress and a bridge pier is to place granular filter material to a depth of about 1 m (3 ft) below the streambed for about 5 m (16 ft) around the pier. The geotextile filter and block mat placed on the streambed overlap this granular filter layer and the remaining gap between the mat and the pier is filled with riprap. Successful field installations have apparently been made using this technique (Figure 4.11).

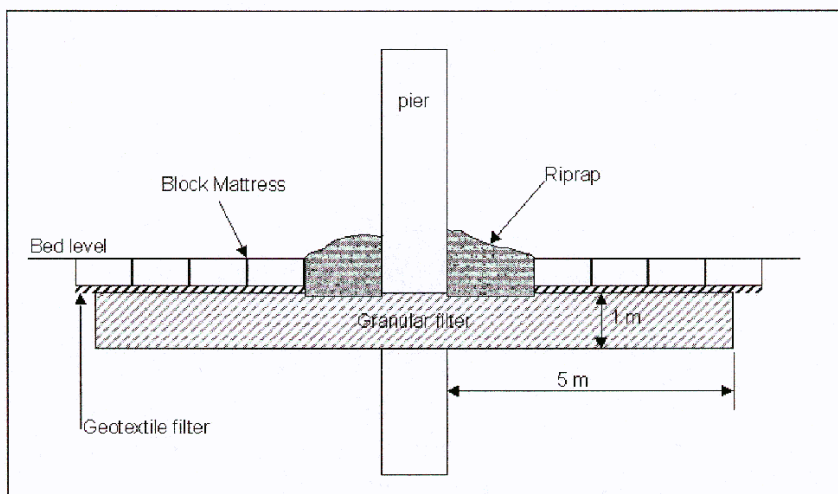

Figure 4.11. Use of granular filter and riprap to seal the joint between a bridge pier and articulating block mattress.⁽¹²⁾

4.5 REFERENCES

1. Brown, S.A. and E.S. Clyde, 1989, "Design of Riprap Revetment," Hydraulic Engineering Circular No. 11, FHWA-IP-016, prepared for FHWA, Washington, D.C.
2. Holtz, D.H., B.R. Christopher, and R.R. Berg, 1995, "Geosynthetic Design and Construction Guidelines," National Highway Institute, Publication No. FHWA HI-95-038, Federal Highway Administration, Washington D.C., May.
3. Clopper, P.E. and Y. Chen, 1988, "Minimizing Embankment Damage During Overtopping Flow," FHWA-RD-88-181, Office of Engineering and Highway Operations R&D, McLean, VA.
4. Clopper, P.E., 1989, "Hydraulic Stability of Articulated Concrete Block Revetment Systems During Overtopping Flow," FHWA-RD-89-199, Office of Engineering and Highway Operations R&D, McLean, VA.
5. Clopper, P.E., 1992, "Protecting Embankment Dams with Concrete Block Systems," Hydro Review, Vol. X, No. 2, April.
6. Stevens, M.A., 1968, "Scouring of Riprap at Culvert Outlets," Ph.D. Dissertation, Dept. of Civil Engineering, Colorado State University, Fort Collins, CO.
7. Richardson, E.V., D.B. Simons, and P.F. Lagasse, 2001, "River Engineering for Highway Encroachments - Highways in the River Environment," Report FHWA NHI 01-004, Federal Highway Administration, Hydraulic Design Series No. 6, Washington, D.C.
8. McCorquodale, J.A., 1993, "Cable-tied Concrete Block Erosion Protection," Hydraulic Engineering '93, San Francisco, CA, Proceedings (1993), pp. 1367-1362.
9. McCorquodale, J.A., 1991, "Guide for the Design and Placement of Cable Concrete Mats," Report Prepared for the Manufacturers of Cable Concrete.
10. Parker, G., C. Toro-Escobar, and R.L. Voight, Jr., 1998, "Countermeasures to Protect Bridge Piers from Scour," User's Guide, Vol. 1, prepared for National Cooperative Highway Research Program, Transportation Research Board, National Research Council, NCHRP Project 24-7, St. Anthony Falls Laboratory, University of Minnesota, Minneapolis, MN (revised 7/1/99).
11. Parker, G., C. Toro-Escobar, and R.L. Voight, Jr., 1998, "Countermeasures to Protect Bridge Piers from Scour," Final Report, Vol. 2, prepared for National Cooperative Highway Research Program, Transportation Research Board, National Research Council, NCHRP Project 24-7, St. Anthony Falls Laboratory, University of Minnesota, Minneapolis, MN.
12. Transportation Research Board, 1999, "1998 Scanning Review of European Practice for Bridge Scour and Stream Instability Countermeasures," National Cooperative Highway Research Program, Research Results Digest Number 241, July, Washington, D.C.

4.6 CONTACTS

Federal Highway Administration
RD&T, Turner Fairbank Highway Research Center
6300 Georgetown Pike
McLean, Virginia 22101-2296

Ayres Associates, Inc.
3665 John F. Kennedy Parkway
Building 2, Suite 200
Fort Collins, Colorado 80525

(page intentionally left blank)

DESIGN GUIDELINE 5
GROUT FILLED MATTRESSES

(page intentionally left blank)

DESIGN GUIDELINE 5

GROUT FILLED MATTRESSES

5.1 INTRODUCTION

Grout filled mattresses (mats) are a type of fabric formed concrete used as armor for channel side slope and/or channel bed protection. Fabric forms for concrete come in many different designs, but all have the same general concept. A strong synthetic fabric is sewn into a series of bags that are connected internally by ducts. These bags are then filled with a cement rich concrete grout. When set, the concrete forms a mat made up of a grid of connected blocks. While the individual blocks may articulate within the mat and the mat remain structurally sound, the general design approach is to consider the mat as a rigid monolithic layer.

5.2 HYDRAULIC STABILITY OF GROUT FILLED MATS ON A CHANNEL BED

Hydrodynamic forces of drag and lift both act to destabilize a revetment mattress. The destabilizing forces are resisted by the mattress weight and frictional resistance between the bottom of the mat and the channel subgrade material. Because grout filled mats are in essence a thin-section monolithic layer, the mode of failure exhibited in field installations is one of sliding. In the following discussion, it is assumed that potential uplift force due to soil pore water pressure beneath the mat is negligible, or that allowance for pressure relief has been made by selecting a mat that has filter points or weep holes.

Figure 5.1 provides a schematic diagram showing the forces involved in the stability analysis of grout filled mats on a channel bed.

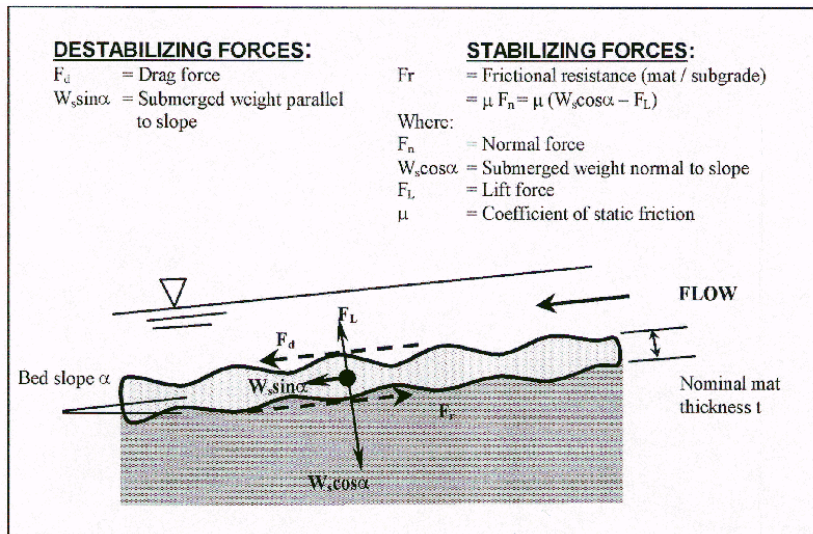

Figure 5.1. Forces acting on a grout filled mat system on a channel bed.

5.2.1 Forces Causing Sliding

Per unit area, the net force F_s causing sliding to occur includes the component of submerged weight parallel to the bed slope, and the drag force F_d which is equal to the bed shear stress τ_0 :

$$F_s = W_s \sin \alpha + F_d \quad (5.1)$$

$$= t(\gamma_c - \gamma_w) \sin \alpha + \tau_0 \quad (5.2)$$

where:

$$\begin{aligned} W_s &= \text{Submerged unit weight of the grout filled mat, N/m}^2 \text{ (lb/ft}^2\text{)} \\ t &= \text{Nominal mat thickness, m (ft)} \\ \gamma_c &= \text{Unit weight of concrete grout, N/m}^3 \text{ (lb/ft}^3\text{)} \\ \gamma_w &= \text{Unit weight of water, N/m}^3 \text{ (lb/ft}^3\text{)} \\ \alpha &= \text{Bed slope, degrees} \end{aligned}$$

The bed shear stress τ_0 is typically calculated as:

$$\tau_0 = (\gamma_w) y_0 S_f \quad (5.3)$$

where:

$$\begin{aligned} \tau_0 &= \text{Bed shear stress, N/m}^2 \text{ (lb/ft}^2\text{)} \\ y_0 &= \text{Flow depth, m (ft)} \\ S_f &= \text{Slope of the energy grade line, m/m (ft/ft)} \end{aligned}$$

Where the flow is constricted such as between bridge abutments, or obstructed such as at piers, use of the local bed shear stress equation is recommended:

$$\tau_0 = f \rho V^2 / 8 \quad (5.4)$$

where:

$$\begin{aligned} \tau_0 &= \text{Bed shear stress, N/m}^2 \text{ (lb/ft}^2\text{)} \\ f &= \text{Darcy friction factor} \\ \rho &= \text{Density of water, kg/m}^3 \text{ (slugs/ft}^3\text{)} \\ V &= \text{Local velocity in constricted or obstructed reach, m/s (ft/s)} \end{aligned}$$

5.2.2 Resistance to Sliding

Per unit area, the resistance against sliding F_r is the net normal force F_n on the bed multiplied by the coefficient of static friction:

$$\begin{aligned} F_r &= \mu F_n = \mu [W_s \cos \alpha - F_L] \\ &= \mu [t(\gamma_c - \gamma_w) \cos \alpha - F_L] \end{aligned} \quad (5.5)$$

where:

$$\begin{aligned} F_L &= \text{Hydrodynamic lift force per unit area, N/m}^3 \text{ (lb/ft}^2\text{)} \\ \mu &= \text{Coefficient of static friction} \end{aligned}$$

As a conservative first approach, the lift force per unit area F_L is assumed to act in a direction normal to the bed slope with a magnitude equal to the drag force F_d :

$$F_L = F_d = \tau_0 \quad (5.6)$$

Therefore:

$$F_r = \mu [t(\gamma_c - \gamma_w)\cos\alpha - \tau_0] \quad (5.7)$$

5.2.3 Factor of Safety Against Sliding

The sliding factor of safety FS is the ratio of forces resisting sliding to forces causing sliding to occur:

$$FS = \frac{F_r}{F_s} = \mu \left[\frac{t(\gamma_c - \gamma_w)\cos\alpha - \tau_0}{t(\gamma_c - \gamma_w)\sin\alpha + \tau_0} \right] \quad (5.8)$$

For typical applications in natural channels where the bed slope S_0 is less than about 0.02 m/m (ft/ft) (2 percent), $\sin\alpha \approx 0$, $\cos\alpha \approx 1$, and Equation 5.8 can be simplified to:

$$FS = \frac{\mu}{\tau_0} [(t(\gamma_c - \gamma_w) - \tau_0)] \quad (5.9)$$

In practice, the coefficient of static friction μ depends on the characteristics of the mat-subsoil interface, which is a function of the mat geometry, geotextile, soil type, and degree to which the mat can be seated into the subsoil to achieve intimate contact. Manufacturers typically supply the value of μ for use with their various products for different soil types. For example, recommended values for the various grout filled Armorform™ products range from 0.47 to 1.0.⁽¹⁾ These design values may often be quoted as an equivalent angle of sliding friction, δ , expressed in degrees. The relationship between μ and δ is:

$$\mu = \tan \delta \quad (5.10)$$

Manufacturers should also supply the appropriate Manning's n resistance coefficient for each product. Grout filled mat systems can range from very smooth, uniform surface conditions approaching cast in place concrete in terms of surface roughness, to extremely irregular surfaces exhibiting substantial projections into the flow, resulting in boundary roughness approaching that of moderate size rock riprap.

5.3 HYDRAULIC STABILITY OF GROUT FILLED MATS ON A CHANNEL SIDE SLOPE

An expression can be developed for the hydraulic stability of mats on a channel side slope using similar logic as in the development of the equations for mats on a channel bed. In typical applications, the normal force that produces the frictional resistance against sliding is usually smaller for the channel side slopes compared to the channel bed, due to the steeper slope angle. This effect is partially offset by the lower shear stress imparted to the side slope by the flow compared to that on the bed, and the fact that the shear stress does not act in the same direction as the plane of the slope. As with the previous development, it is assumed that potential uplift force due to soil pore water pressure beneath the mat is negligible or provision for its relief has been made.

Figure 5.2 provides a schematic diagram showing the forces involved in the stability analysis of grout filled mats on a channel side slope.

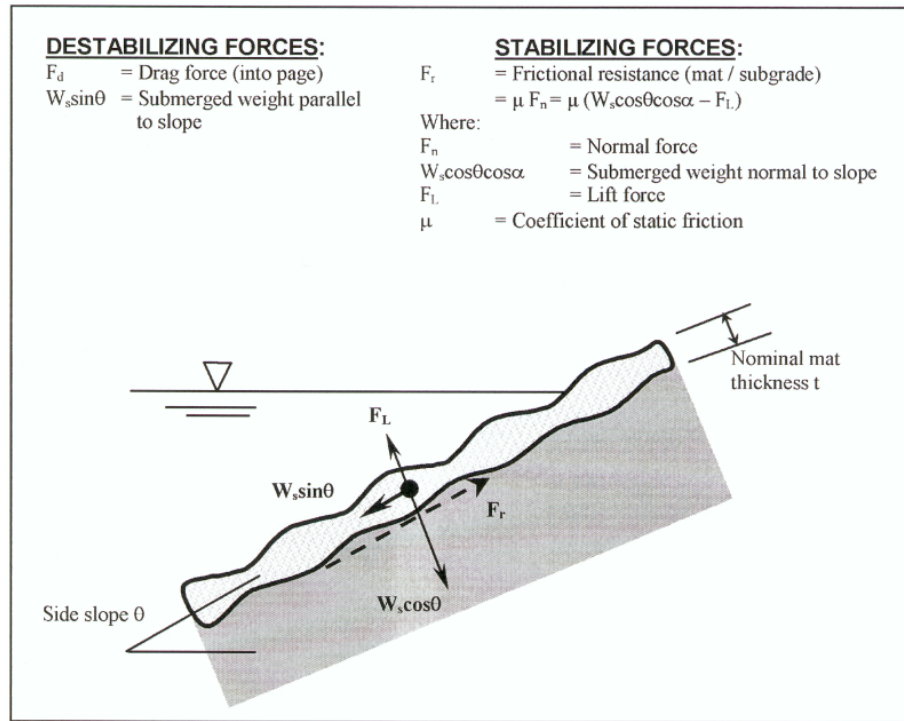

Figure 5.2. Forces acting on a grout filled mat system on a channel side slope.

5.3.1 Forces Causing Sliding

Per unit area, the net force F_s causing sliding to occur includes the component of submerged weight W_s in the plane of the side slope, and the drag force F_d which is equal to the shear stress τ_s on the side slope. The drag force acts in the direction of flow and therefore is not directly additive to the submerged weight component. The vector sum of these forces is:

$$F_s = \sqrt{(t(\gamma_c - \gamma_w) \sin \theta)^2 + (\tau_s)^2} \quad (5.11)$$

where:

- t = Nominal mat thickness, m (ft)
- γ_c = Unit weight of concrete grout, N/m³ (lb/ft³)
- γ_w = Unit weight of water, N/m³ (lb/ft³)
- θ = Side slope, degrees
- τ_s = Shear stress on side slope, N/m² (lb/ft²)

Shear stress on a side slope should be corrected for the effects of nonuniform flow distribution by multiplying the bed shear stress, τ_0 , by correction factors K_s for side slope reduction and K_b for the effects of channel bends:

$$\tau_s = K_s K_b \tau_0 \quad (5.12)$$

Values of K_s for typical side slopes, Z, in trapezoidal channels are summarized in Equations 5.13 through 5.15:⁽²⁾

$$K_s = 0.94 \text{ for } Z = 4\text{H:1V } (\theta = 14.0^\circ) \quad (5.13)$$

$$K_s = 0.85 \text{ for } Z = 3\text{H:1V } (\theta = 18.4^\circ) \quad (5.14)$$

$$K_s = 0.79 \text{ for } Z = 2\text{H:1V } (\theta = 26.6^\circ) \quad (5.15)$$

Values of K_b for determining the increased shear stress on the outside of channel bends can range from about 1.1 for mild curvature to 2.0 or more for sharp bends. FHWA's Hydraulic Engineering Circular No. 15⁽³⁾ provides additional guidance on selecting an appropriate K_b value based on channel width and bend radius.

5.3.2 Resistance to Sliding

Similar to the case of mats placed on a channel bed, the resistance against sliding F_r is the net normal force on the bed multiplied by the coefficient of static friction:

$$\begin{aligned} F_r &= \mu F_n = \mu [W_s \cos \theta \cos \alpha - F_L] \\ &= \mu [t(\gamma_c - \gamma_w) \cos \theta \cos \alpha - F_L] \end{aligned} \quad (5.16)$$

As with mats placed on a channel bed, the lift force per unit area F_L is conservatively assumed to act in a direction normal to the bed slope with a magnitude equal to the drag force F_d :

$$F_L = F_d = \tau_s \quad (5.17)$$

Therefore:

$$F_r = \mu [t(\gamma_c - \gamma_w) \cos \theta \cos \alpha - \tau_s] \quad (5.18)$$

5.3.3 Factor of Safety Against Sliding

The sliding factor of safety FS is the ratio of forces resisting sliding to forces causing sliding to occur:

$$FS = \mu \left[\frac{t(\gamma_c - \gamma_w) \cos \theta \cos \alpha - \tau_s}{\sqrt{[t(\gamma_c - \gamma_w)(\sin \theta)]^2 + (\tau_s)^2}} \right] \quad (5.19)$$

5.4 SELECTION OF FACTOR OF SAFETY

The designer must determine what factor of safety should be used for a particular design. Some variables which should affect the selection of the factor of safety used for final design are: risks associated with a failure of the project, the uncertainty of hydraulic values used in the design, and uncertainties associated with installation practices. Typically, a minimum factor of safety of 1.5 is used for revetment design when the project hydraulic conditions are well known and variations in the installation can be accounted for. Additional correction factors and/or higher factors of safety are typically used for protection at bridge piers, abutments and at channel bends due to the complexity in computing shear stress at these locations. **Research is being conducted to determine appropriate factors for bridge piers and abutments.**

5.5 INSTALLATION GUIDELINES

5.5.1 General

The selection of an appropriate mat size can be computed by applying the methodologies discussed above given the appropriate data from the manufacturer. Guidelines on the selection, design, and specifications of filter material can be found in HEC-11⁽⁴⁾ and Holtz et al. (FHWA HI-95-038).⁽⁵⁾

5.5.2 Oregon Installation

A particular design called “articulating block mat” (ABM), used by the Oregon Department of Transportation, has two features which make it distinctive among fabric formed concrete mats. First, the horizontal seams within the mat are continuous, allowing the blocks to bend downward by hinging along this seam line. Second, the individual blocks are connected internally by a series of flexible polyester cables which keep the individual blocks firmly connected while allowing them to bend (Figure 5.3). Typical individual block sizes are on the order of 0.2 m² to 0.37 m² (2.25 ft² to 4.0 ft²) and the mass is approximately 180 kg (400 lb) each.

The following recommendations reflect experience from the Oregon Department of Transportation (ODOT) and Arizona Department of Transportation (ADOT). Research reports from an ODOT installation of an articulating grout filled mat erosion control system on Salmon Creek in Oakridge, Oregon also provide experience and insight on the use of these mats.^(6,7)

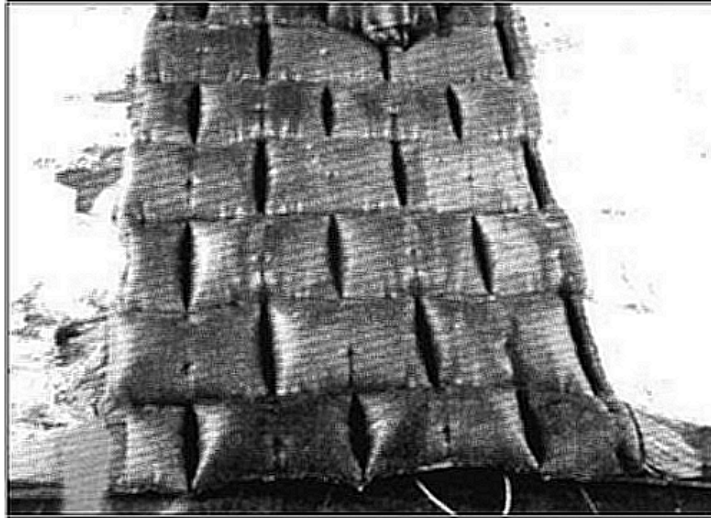

Figure 5.3. Articulating block mat appearance after filling (ODOT).

1. Both upstream and downstream ends of the mat should be trenched (Figure 5.4). The use of tension anchors can increase the stability of the mattress at the edges.
2. All edges should be keyed in and protected to prevent undermining and flow behind the mat.
3. At abutments, the mat can be wrapped around the abutment and buried to provide anchorage and to control flanking.
4. It is recommended that weep holes be cut into the fabric at the seam to allow for proper drainage relief of pore pressure in the subgrade.
5. The mattress should be filled with portland cement slurry consisting of a mixture of cement, fine aggregate, and water. The mix should be in such proportion of water to be able to pump the mix easily, while having a compressive strength of 17,243 kPa (2500 psi).
6. Fabric mats have been installed on slopes of 1V:1.5H or flatter.
7. Large boulders, stumps and other obstructions should be removed from slopes to be protected to provide a smooth application surface.
8. Use sand and gravel for any backfill required to level slopes. Silty sand is acceptable if silt content is 20 percent or less. Do not use fine silt, organic material or clay for backfill.
9. The injection sequence should proceed from toe of slope to top of slope, but the mat should be anchored at the top of slope first by pumping grout into the first rows of bags, by attaching the mat to a structure, or using tension anchors (see recommended injection sequence in Figures 5.4 and 5.5).

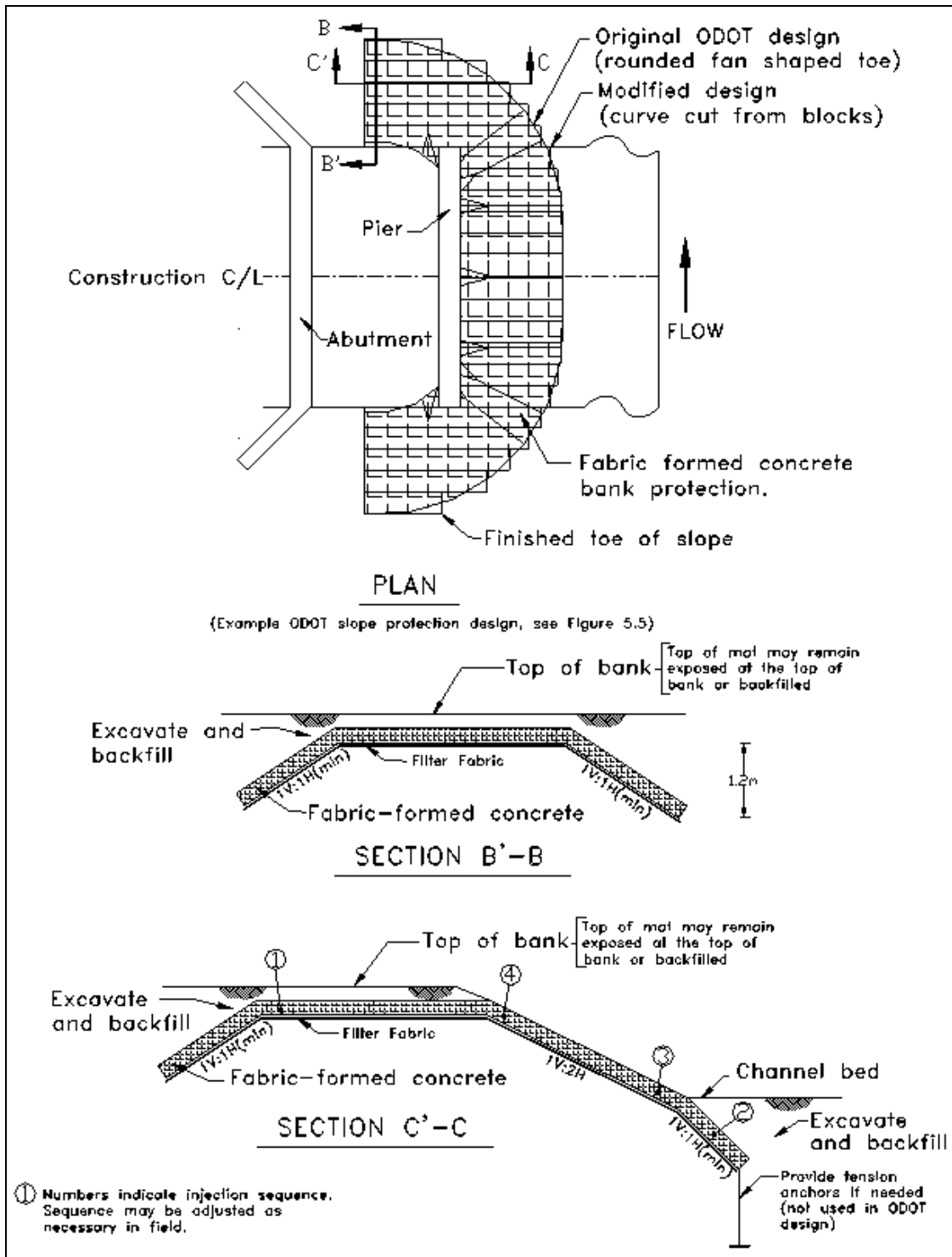

Figure 5.4. Typical articulated grout filled mat design.^(6,7)

10. If the mat is to be permanently anchored to a pier or abutment there are implications which must be considered when using this technique. The transfer of moments from the mat to the pier may affect the structural stability of the bridge. When the mat is attached to the pier the increased loadings on the pier must be investigated.
11. Curved edge designs may require communication with the fabric manufacturer on shaping limitations and field adjustments.
12. The need for a geotextile or granular filter should be addressed. Guidelines on the selection, design, and specifications of filter material can be found in HEC-11⁽⁴⁾ and Holtz et al. (FHWA HI-95-038).⁽⁵⁾



Figure 5.5. Installation of articulating grout filled mat proceeding upslope (ODOT).⁽⁶⁾

Figure 5.4 illustrates some of the installation features specified by ODOT on the Salmon Creek Bridge as well as typical design features.^(6,7) Notice that the original ODOT design was modified by the manufacturer due to the limitations of the product. The fabric forms could not be terminated in a smooth fan shaped pattern as shown in the original ODOT design. Therefore, the mat was cut at the seams to best fit the original design. It was anticipated that this would make the system somewhat less effective than the original design because of a greater susceptibility to undermining of the edges. Figures 5.6 and 5.7 show the final installation of the articulating block mat at Salmon Creek Bridge.

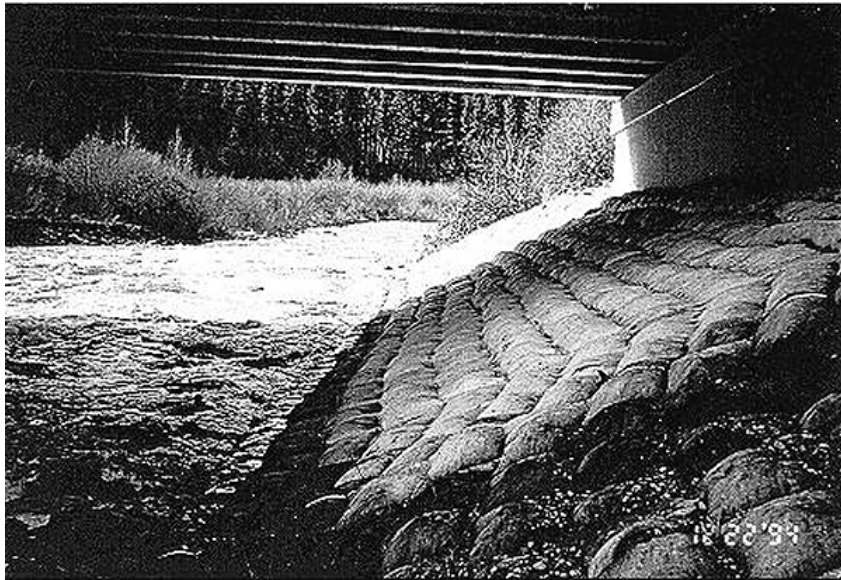

Figure 5.6. ABM underneath Salmon Creek Bridge (ODOT).⁽⁶⁾



Figure 5.7. ABM installed on west bank of Salmon Creek (ODOT).⁽⁶⁾

Some Problems and solutions identified in the construction process by ODOT are:^(6,7)

1. *Problem:* In the original attempt to create a smooth working surface for laying the fabric, sand was placed over the native material. This was a problem because footprints readily disturbed the surface.
Solution: The native material (a gravelly sand) was used for the final surface by first clearing it of major rocks, then compacting it.
2. *Problem:* There was difficulty in estimating where the toe of the finished slope would be.
Solution: Assume that the fabric contracts by 10% in length after filling with grout.
3. *Problem:* It was difficult to maintain straight lines along the horizontal seams when pumping grout.
Solution: The fabric was kept straight by tying it to a series of #6 reinforcing bars.
4. *Problem:* Several of the bags were sewn in such a way that the grout ducts connecting them to the other bags were blocked off. This occurred mostly in areas where the bags were cut during fabrication to only 1/2 the original size.
Solution: The bags were split and filled individually. This should not affect the strength or function of the system.

5.5.3 South Dakota Installation

Some early installations of concrete fabric mats were completed on Spring Creek and Battle Creek in South Dakota in the early 1970s.^(8,9) These installations used much larger sections (1.9 m² [20.5 ft²]) than those shown in the Oregon DOT installation. The simplicity of construction and durability of these mats made them an attractive erosion control alternative. Experience and technology have improved the performance of fabric formed concrete mats since the 1970s.

5.6 SPECIFICATIONS

Specifications on fabric forms were not provided by the states. However specifications on the tensile and tear strength of fabric used for grout bags can be found in Design Guideline 7. The American Society for Testing of Materials (ASTM) Subcommittee D18.25 on Erosion and Sediment Control Technology is currently developing standards for fabric formed concrete systems.

5.7 REFERENCES

1. Nicolon Corporation, 1989, "Design Manual for Armorform™ Erosion Protection Mats." Prepared by Bowser-Morner Associates, Inc., September.
2. U.S. Army Corps of Engineers, 1981, "Final Report to Congress: The Streambank Erosion Control Evaluation and Demonstration Act of 1974, Section 32, Public Law 93-251." Supplemented by Appendix B, "Hydraulic Research," and Appendix C, "Geotechnical Research," December.

3. Chen, Y.H. and C.K. Cotton, 1986, "Design of Roadside Channels with Flexible Linings," Hydraulic Engineering Circular No. 15, FHWA-IP-86-5, Office of Implementation, HRT-10, Federal Highway Administration, McLean, VA.
4. Brown, S.A. and E.S. Clyde, 1989, "Design of Riprap Revetment," Hydraulic Engineering Circular No. 11, FHWA-IP-016, prepared for FHWA, Washington, D.C.
5. Holtz, D.H., B.R. Christopher, and R.R. Berg, 1995, "Geosynthetic design and Construction Guidelines," National Highway Institute, Publication No. FHWA HI-95-038, Federal Highway Administration, Washington, D.C., May.
6. Scholl, L.G., 1991, "ARMORFORM® Articulating Block Mat Erosion Control System, Salmon Creek Bridge; Oakridge, Oregon, Construction Report," Oregon Experimental Feature #OR89-05, for Oregon Department of Transportation, Materials and Research Section, Salem, OR.
7. Hunt, Liz, 1993, "ARMORFORM® Articulating Block Mat Erosion Control System, Salmon Creek Bridge; Oakridge, Oregon, Interim Report," Oregon Experimental Feature #OR89-05, for Oregon Department of Transportation, Materials and Research Section, Salem, OR.
8. Brice, J.C. and J.C. Blodgett, 1978, "Countermeasure for Hydraulic Problems at Bridges, Volumes 1 and 2," FHWA-RD-78-162 and 163, USGS, Menlo Park, CA.
9. Karim, M., 1975, "Concrete Fabric Mat," Highway Focus, Vol. 7, pp. 16 - 23.

5.8 CONTACTS

Oregon Department of Transportation
329 Transportation Building
Salem, Oregon 97310

Arizona Department of Transportation
205 South 17th Avenue, M.D. 635 E.
Phoenix, Arizona 85007

DESIGN GUIDELINE 6
CONCRETE ARMOR UNITS

(page intentionally left blank)

DESIGN GUIDELINE 6

CONCRETE ARMOR UNITS

6.1 INTRODUCTION

Concrete armor units are man-made 3-dimensional shapes fabricated for soil stabilization and erosion control. These structures have been used in environments where riprap availability is limited or where large rock sizes are required to resist extreme hydraulic forces. They have been used as revetments on shorelines, channels, streambanks and for scour protection at bridges. Some examples of armor units include Toskanes, A-Jacks[®], tetrapods, tetrahedrons, dolos and Core-loc[™] (Figure 6.1).

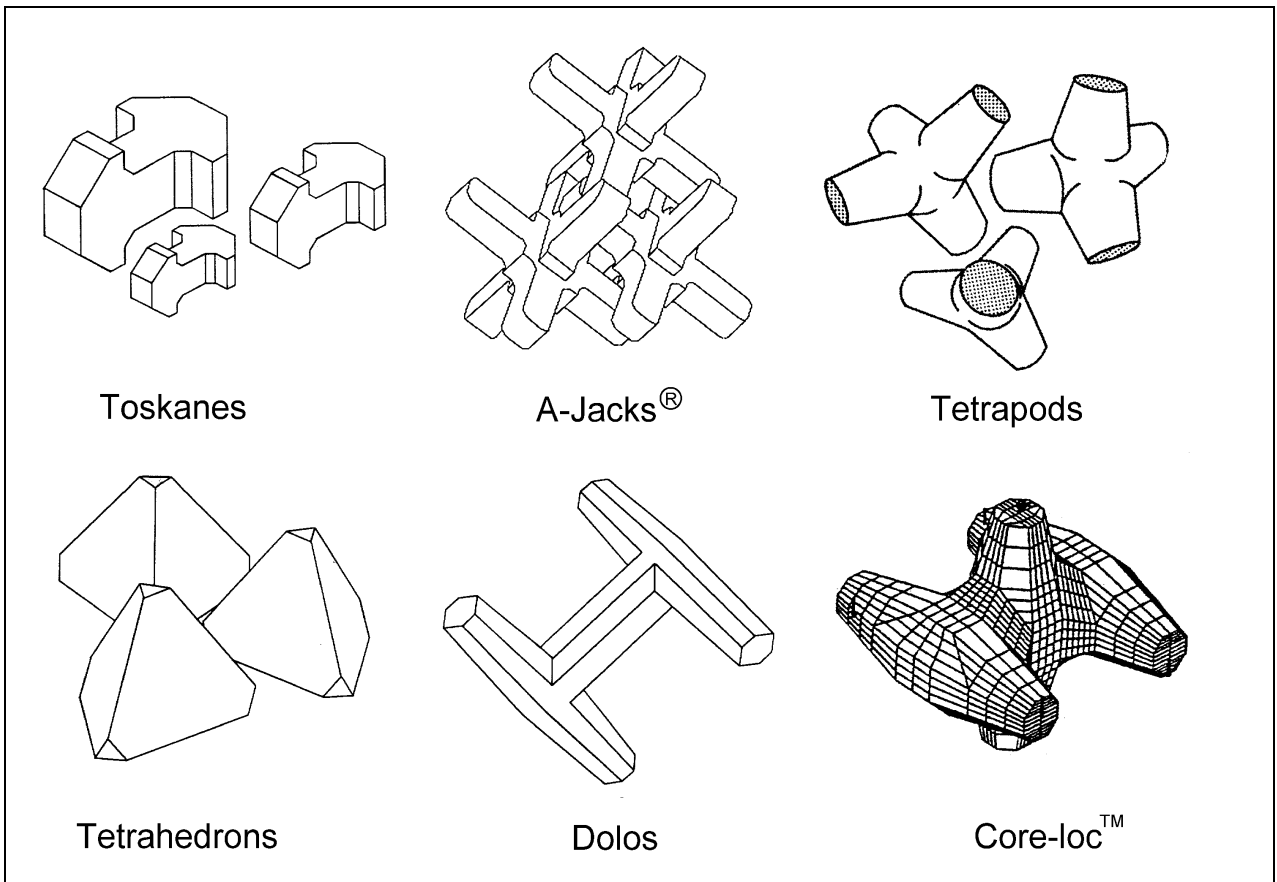

Figure 6.1. Armor units.

The primary advantage of armor units is that they usually have greater stability compared to riprap. This is due to the interlocking characteristics of their complex shapes. The increased stability allows their placement on steeper slopes or the use of lighter weight units for equivalent flow conditions as compared to riprap. This is significant when riprap of a required size is not available.

6.2 DESIGN CRITERIA FOR CONCRETE ARMOR UNITS IN OPEN CHANNELS

The design of armor units in open channels is based on the selection of appropriate sizes and placement patterns to be stable in flowing water. The armor units should be able to withstand the flow velocities without being displaced. Hydraulic testing is used to measure the hydraulic conditions at which the armor units begin to move or "fail," and dimensional analysis allows extrapolation of the results to other hydraulic conditions. Although a standard approach to the stability analysis has not been established, design criteria have been developed for various armor units using the following dimensionless parameters:

- Isbash stability number^(1, 2, 3)
- Shields parameter⁽³⁾
- Froude number⁽⁴⁾

The Isbash stability number and Shields parameter are indicative of the interlocking characteristics of the armor units. Froude number scaling is based on similitude of stabilizing and destabilizing forces. Quantification of these parameters requires hydraulic testing and, generally, regression analysis of the data. Prior research and hydraulic testing have provided guidance on the selection of the Isbash stability number and Shield's parameter for riprap and river sediment particles, but stability values are not available for all concrete armor units. Therefore, manufacturers of concrete armor units have a responsibility to test their products and to develop design criteria based on the results of these tests. Since armor units vary in shape and performance from one proprietary system to the next, each system will have unique design criteria.

Installation guidelines for concrete armor units in streambank revetment and channel armor applications should consider subgrade preparation, edge treatment (toe down and flank) details, armor layer thickness, and filter requirements. Subgrade preparation and edge treatment for armor units is similar to that required for riprap and general guidelines are documented in HEC-11.⁽⁴⁾ Considerations for armor layer thickness and filter requirements are product specific and should be provided by the armor unit manufacturer.

6.3 APPLICATION OF CONCRETE ARMOR UNITS TO LOCAL SCOUR PROTECTION

Concrete armor units have shown potential for mitigating the effects of local scour in the laboratory, however limited field data are available on their performance. Research efforts are currently being conducted to test the performance of concrete armor units as pier scour countermeasures in the field.

Design methods which incorporate velocity (a variable which can be directly measured) are commonly used to select local scour countermeasures. Normally an approach velocity is used in the design equation (generally a modified Isbash equation) with a correction factor for flow acceleration around the pier or abutment (see for example, Design Guideline 8). A specific design procedure for Toskanes has been developed for application at bridge piers and abutments and is described in Sections 6.4 through 6.9 to illustrate a general design approach where the Toskanes are installed as individual, interlocking units.

Another approach to using concrete armor units for pier scour protection has been investigated by the Armortec Company and involves the installation of banded modules of the A-Jacks[®] armor unit. Laboratory testing results and installation guidelines for the A-Jacks

system are presented in Section 6.10 to illustrate the "modular" design approach in contrast with the "discrete particle" approach for Toskanes.

6.4 TOSKANE DESIGN PROCEDURE FOR PIER SCOUR PROTECTION

The Pennsylvania Department of Transportation (PennDOT) contracted with Colorado State University (CSU) in 1992 to investigate concrete armor units as a countermeasure for local scour at bridge piers. The purpose of the research was to develop guidelines for selection and placement of cost-effective armor unit sizes to mitigate pier scour.^(5,6) A literature review of concrete armor units used in coastal and river protection works led to the selection of the Toskane as the primary concrete armor unit for which guidelines were to be developed. The Toskanes were modified from those used in coastal applications by removing the pointed corners from the hammerheads, increasing the length and cross section of the beam, and including reinforcing steel in the beam.

Hydraulic tests to evaluate the performance of Toskanes were conducted in an indoor flume and two outdoor flumes at CSU. Over 400 test runs were conducted. These tests included random and pattern placement of Toskanes tested to failure around piers and abutments, determination of protective pad radius, determination of pad height (comparing installations in which the top of the pad was level with the bed and installations in which the pad protruded above the bed), comparison of gravel and geotextile filters, number of Toskanes per unit area, and effect of angle of attack on Toskanes at a round nose pier. The data were analyzed, and using dimensional analysis the significant parameters were determined.

The design equation developed from regression analysis of hydraulic test data at CSU allows the computation of the equivalent spherical diameter of a stable Toskane size. The equivalent spherical diameter is the size of a sphere that would have the same volume of material as the armor unit as determined by the following equation:

$$D_u = \frac{0.255V_v \sqrt{\frac{b_a}{g}}}{(S_g - 1)} \quad (6.1)$$

where:

- D_u = equivalent spherical diameter, m (ft)
- V_v = corrected velocity value = $1.5 \cdot V_o \cdot C_l \cdot C_s \cdot C_h \cdot C_i$, m/s (ft/s)
- C_l = location coefficient
- C_s = shape coefficient
- C_h = height coefficient
- C_i = installation coefficient
- b_a = adjusted structure width normal to the flow (pier or abutment), m (ft)
- g = acceleration of gravity, m/s^2 (ft/s^2)
- S_g = specific gravity of Toskanes

Given the hydraulic conditions and dimensions of the pier or abutment, Equation 6.1 can be solved to select an appropriate size of Toskane for local scour protection. The design parameters and dimensions of Toskanes are illustrated in Figure 6.2.

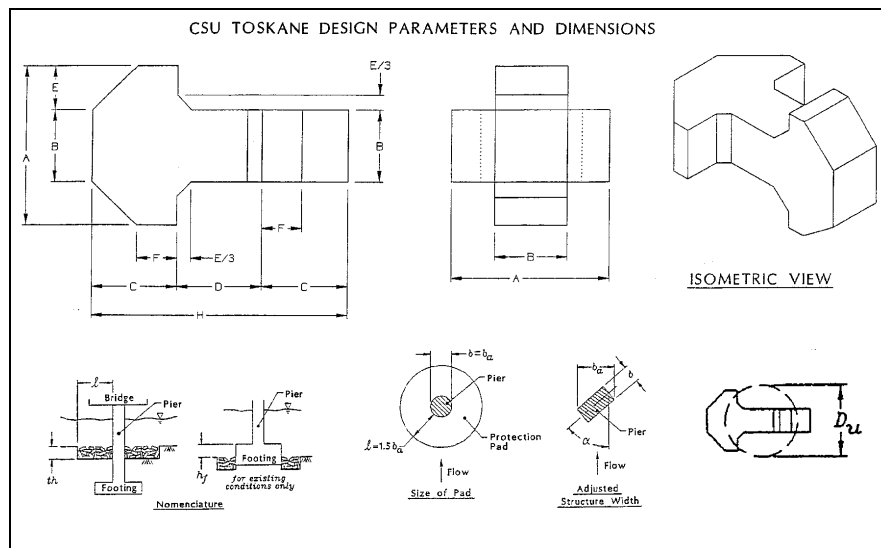

Figure 6.2. Toskane design parameters and dimensions.

The actual dimensions of the Toskanes are dependent on the size of unit constructed. Relative design dimensions are listed in Table 6.1.

Du	0.622H
A	0.616H
B	0.280H
C	0.335H
D	0.330H
E	0.168H
F	0.156H

The equivalent spherical diameter of the units constructed should equal or exceed the value determined from Equation 6.1. Custom sizes of Toskanes may be selected, but it may be more cost effective to use a standard size. Recommended standard sizes of Toskanes are listed in Table 6.2.

Metric Units		English Units	
Du (m)	Mass (kg)	Du (ft)	Weight (lb)
.430	100	1.47	250
.542	200	1.85	500
.653	350	2.12	750
.735	500	2.33	1,000
.823	700	2.67	1,500
.894	900	2.94	2,000

Tables 6.1 and 6.2 provide information necessary for construction of individual armor units once an appropriate size is selected. Design parameters for installation of a protection pad are provided in Table 6.3.

Table 6.3. Toskane Design Parameters and Dimensions.	
Design Parameter Dimension	
Toskane length (H)	1.608Du
Equivalent spherical diameter (Du)	0.622H
Volume (V)	$0.5236Du^3 = 0.1263H^3$
Specific weight (γ)	23.5 KN/m ³ 150 lb/ft ³
Density (ρ)	2400 kg/m ³ 4.66 slug/ft ³
Number of Toskanes per unit area (N)**	$0.85V^{-2/3} = 1.309Du^{-2}$
2 layer thickness (th)	2.0Du = 1.24H
Filter requirements	$D_{85(\text{filter})} = 0.22Du$
Size of Pad (l)	$l_{\min} = 1.5b_a$ (piers) $l_{\min} = 2.0b_a$ (abutments)
**Toskanes per unit area assuming a 2-layer thickness of 2Du.	

6.5 TOSKANE DESIGN GUIDELINES

The following design guidelines reflect the results of the research conducted at CSU:^(5,6)

1. Determine the velocity:

- a. Calculate the average velocity of the river directly upstream of the bridge (approximately 3 m (10 ft) upstream). Consider the number of substructure elements in the flow at the bridge cross section. If constriction could be significant, increase the approach flow velocity accordingly.

V_o = average velocity directly upstream of the bridge (m/s) (ft/sec)

- b. Select an adjustment coefficient to account for the location of the pier or abutment within the cross section. Some judgment is needed for selecting the coefficient, C_i , but generally a coefficient at 1.0 to 1.1 can be used.

$C_i = 0.9$, for a location near the bank of the river.

$C_i = 1.0$, for most applications

$C_i = 1.1$, for a structure in the main current of flow at a sharp bend.

$C_i = 1.2$, for a structure in the main current of the flow around an extreme bend, possible cross flow generated by adjacent bridge abutments or piers.

NOTE: HEC-18⁽⁷⁾ recommends values of C_i as large as 1.7 (see Design Guideline 8).

Alternatively, a hydraulic computer model could be used to determine the local velocities directly upstream of bridge piers or abutments. A 1-dimensional hydraulic model (i.e., HEC-RAS, WSPRO) could be used to compute velocity distributions within a cross section on a relatively straight reach. A 2-dimensional hydraulic model (i.e., FESWMS, RMA-2V) could be used to estimate local velocities in meandering reaches or reaches with complex flow patterns.

- c. Select an adjustment coefficient for shape of the pier or abutment. As with the CSU equation for pier scour, if the angle of attack, α , is greater than 5°, set all shape coefficients to 1.0.

For piers:

$C_s = 1.0$, for a circular pier.

$C_s = 1.1$, for a square nose pier.

$C_s = 0.9$, for a sharp nose pier streamlined into the approach flow.

For abutments:

$C_s = 1.1$, for a vertical wall abutment.

$C_s = 0.85$, for a vertical wall abutment with wingwalls.

$C_s = 0.65$, for a spill through abutment.

- d. Determine if the top surface of the pad can be placed level with the channel bed and select the appropriate coefficient.

$C_h = 1.0$, Level - Top of pad is flush with the channel bed.

$C_h = 1.1$, Surface - Two layers of pad extend above channel bed.

NOTE: This is not a correction for mounding. Mounding is strongly discouraged because it generates adverse side effects. The effects of mounding were not addressed in the CSU study. Pad heights were kept at 0.2 times the approach flow depth or less.

- e. Select a random or pattern installation for the protection pad. A random installation refers to the units being dumped into position. In a pattern installation, every Toskane is uniformly placed to create a geometric pattern around the pier.

$C_i = 1.0$, Random Installation

$C_i = 0.9$, Pattern 1 - 2 Layers with Filter

$C_i = 0.8$, Pattern 2 - 4 Layers

- f. Calculate the Velocity Value:

Multiply the average approach flow velocity and coefficients by a safety factor of 1.5.

$$V_v = 1.5V_o C_l C_s C_h C_i \quad (6.2)$$

- f. Calculate adjusted structure width, b_a (m) (ft).

For a pier:

a. Estimate angle of attack for high flow conditions.

b. If the angle is less than 5° , use pier width b as the value b_a .

c. If the angle is greater than 5° , calculate b_a :

$$b_a = L \sin \alpha + b \cos \alpha \quad (6.3)$$

where:

- L = length of the pier (m) (ft)
b = pier width (m) (ft)
 b_a = adjusted structure width (m) (ft)
 α = angle of attack

d. If a footing extends into the flow field a distance greater than: $0.1 * y_o$ (approach flow depth) use footing width instead of pier width for b .

e. For an abutment:

Estimate the distance the abutment extends perpendicular to the flow (b) during high flow conditions.

if $b \leq 1.5$ m (5 ft), then $b_a = 1.5$ m (5 ft)

if 1.5 m (5 ft) $\leq b \leq 6$ m (20 ft), then $b_a = b$

if $b_a \geq 6$ m (20 ft), then $b_a = 6$ m (20 ft)

3. Select a standard Toskane size, D_u , using Equation 6.1 with the calculated velocity value, V_v , and the adjusted structure width, b_a . D_u represents the equivalent spherical diameter of riprap that would be required. This parameter can be related to dimensions of the Toskane by $D_u = 0.622H$, where H is the length of the Toskane (Figure 6.2 and Table 6.1).

Check the b_a/D_u ratio using the diameter, D_u , of a standard Toskane size in Table 6.2. If the ratio > 21 , select the next largest size of Toskane. Repeat until ratio < 21 .

4. Select pad radius, ℓ (m) (ft).

1.5 b_a for most piers and 2.0 b_a for most abutments.

Use a larger pad radius if:

- uncertain about angle of attack
- channel degradation could expose footing,
- uncertain about approach flow velocity
- surface area of existing scour hole is significantly larger than pad.

If more than one Toskane pad is present in the stream cross section, check the spacing between the pads. If a distance of 1.5 m (5 ft) or less exists between pads, extend the width of the pads so that they join.

5. Determine the number of Toskanes per unit area from Table 6.3.

a. Determine the protection pad thickness. Pads with randomly placed units have to be a minimum of two layers thick.

b. For a two layer pad with a filter, determine the pad thickness (th) from Table 6.3.

6. If bed material is sand, gravel, or small cobbles, add a cloth or granular filter. Toe in or anchor the filter. If the filter is granular, the d_{85} of the filter material directly below the Toskane layer can be determined from Table 6.3. Additional layers of filter, that may be needed based on the gradation of the bed material, can be designed according to standard requirements. Additional guidelines on the selection and design of filter material can be found in HEC-11⁽⁴⁾ and Holtz et al. (FHWA HI-95-038).⁽⁸⁾

6.6 DESIGN EXAMPLE FOR A BRIDGE PIER (SI)

A bridge over Blue Creek⁽⁵⁾ has a single pier located on the outside of a bend (Figure 6.3). The pier is round nosed and is 1 m wide and 6 m long. The footing is not exposed and bed material is cobbles and gravel. The average velocity directly upstream of the bridge during high flow is 2.5 m/s and has an angle of attack of 15°.

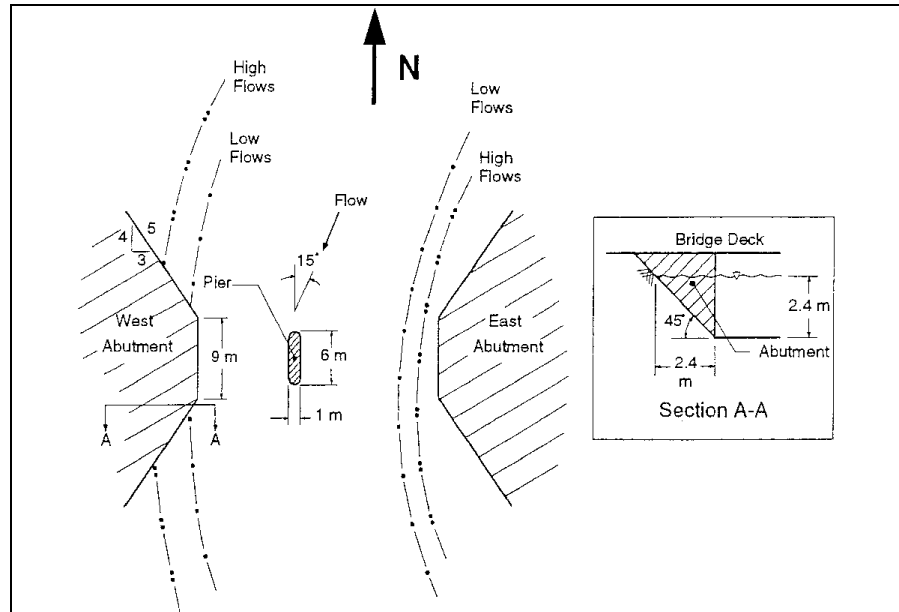

Figure 6.3. Blue Creek site.

1. Determine the velocity value, V_v (m/s).
Because the pier is located in the thalweg of the bend, $C_1 = 1.1$.
The angle of attack, $\alpha = 15^\circ > 5^\circ$, therefore $C_s = 1.0$.
The Toskane pad is installed so that the top of the pad is level with the bed, $C_h = 1.0$.
A randomly installed pad of Toskanes is selected, $C_i = 1.0$.

$$V_v = 1.5V_0 C_1 C_s C_h C_i$$

$$V_v = (1.5)(2.5)(1.1)(1.0)(1.0)(1.0) = 4.1 \text{ m/s}$$

2. Calculate the adjusted structure width, b_a (m).
The angle of attack, $\alpha = 15^\circ$.
Length of pier, $L = 6$ m.
Pier width, $b = 1$ m.

$$b_a = L \sin \alpha + b \cos \alpha$$

$$b_a = L \sin \alpha + b \cos \alpha = 6 \sin (15^\circ) + 1 \cos (15^\circ) = 2.5 \text{ m}$$

3. From Equation 6.1 calculate the equivalent spherical diameter, D_u , for $V_v = 4.1$ m/s and $b_a = 2.5$ m ($S_g = 2.4$).

$$D_u = \frac{0.255V_v \sqrt{\frac{b_a}{g}}}{(S_g - 1)}$$

$$D_u = \frac{0.255(4.1)\sqrt{2.5 / 9.81}}{(1.4)} = 0.377 \text{ m}$$

Using standard sizes (Table 6.2), a 100 kg Toskane unit ($D_u = 0.430\text{m}$) is selected. The ratio $b_a/D_u = 2.5/0.43 = 5.8 < 21$, therefore the size is acceptable.

- Since the engineer is confident about the flow velocity and angle of attack, and the channel is not expected to experience any vertical instability, a pad radius of $\ell = 1.5b_a$ was chosen.

$$\text{Pad Radius, } \ell = 1.5(2.5) = 3.75 \text{ m}$$

The Toskanes will be installed around the pier, a horizontal distance of 3.75 m from the wall of the pier.

- From Table 6.3, the number of Toskanes per unit area for the 100 kg Toskane size with a pad thickness of $2D_u$ is 7.08 Toskanes/ m^2 . Total area of the pad (Figure 6.4) is:

$$\text{Area} = 2(5(3.75)) + (\pi(4.25^2 - 0.5^2)) = 93.5 \text{ m}^2$$

$$\#\text{Toskanes} = 7.08(93.5) = 662 \text{ Toskanes}$$

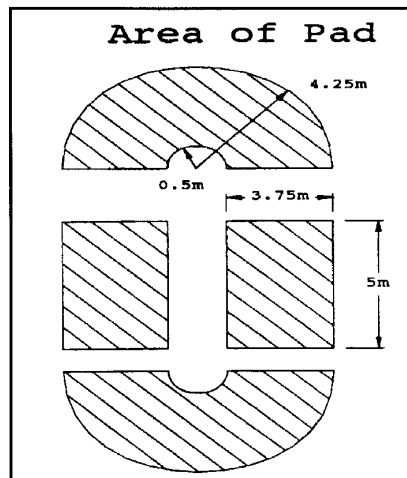

Figure 6.4. Area of pier pad.

The pad thickness is $2D_u = 0.9 \text{ m}$

- Since the bed material is cobbles and gravel, a granular filter is added beneath the pad of Toskanes. The d_{85} of the filter directly beneath the pad of Toskanes is 95 mm. The cobbles and gravel are sufficiently large so no additional filter layers are required.

6.7 DESIGN EXAMPLE FOR A BRIDGE ABUTMENT (SI)

The bridge at Blue Creek⁽⁵⁾ in Figure 6.3 has vertical wall abutments with wing walls. During normal flows the west abutment extends 0.6 m into the flow, but during high flows it obstructs 2.4 m of the flow (normal to the flow field). The embankment slope is at 1H:1V. The east abutment does not obstruct the flow even during high flows.

1. Determine the velocity value, V_v (m/s).
The abutment is located near the bank, outside of the thalweg, $C_l = 0.9$.
Since the abutment has wing walls, $C_s = 0.85$.
The Toskane pad is installed so that the top of the pad is level with the bed, $C_h = 1.0$.
A randomly installed pad of Toskanes is selected, $C_i = 1.0$.

$$V_v = 1.5V_o C_l C_s C_h C_i$$

$$V_v = (1.5)(2.5)(0.9)(0.85)(1.0)(1.0) = 2.87 \text{ m/s}$$

2. Calculate the adjusted structure width, b_a (m).

Since the west river bank has a slope of 1H:1V, an average value is used for the length of abutment that projects perpendicular to the flow. The abutment extends 2.4 m at the water surface and 0 m at the channel bed (Figure 6.3). Therefore an average value of:

$$b_a = \frac{2.4}{2} + 0.0 = 1.2 \text{ m}$$

This is less than the minimum, therefore $b_a = 1.5 \text{ m}$

3. From Equation 6.1 calculate the equivalent spherical diameter, D_u , for $V_v = 2.87 \text{ m/s}$ and $b_a = 1.5 \text{ m}$.

$$D_u = \frac{0.255V_v \sqrt{\frac{b_a}{g}}}{(S_g - 1)}$$

$$D_u = \frac{0.255(2.87) \sqrt{1.5 / 9.81}}{(1.4)} \Rightarrow D_u = 0.204 \text{ m}$$

For the west abutment, the 100 kg Toskane is selected ($D_u = 0.430 \text{ m}$). A smaller 50 kg Toskane could have been selected, but this non-standard size may not be economical to manufacture.

4. Since the engineer is confident about the flow velocity and the channel is assumed vertically stable, a pad radius of $\ell = 2.0b_a$ is recommended.

$$\text{Pad Radius, } \ell = 2.0(1.5) = 3.0 \text{ m}$$

The Toskanes will be installed along the abutment and wingwalls a horizontal distance of 3 m from the wall.

- The pad thickness is $2D_u$ which will result in 7.08 Toskanes/m². The total area of the pad (Figure 6.5) is:

$$\text{Area} = (3)(9) + 2(3)(5) + 2(0.5)(3)(1.8) + 2(0.5)(3)(4) = 74.4 \text{ m}^2$$

$$\#\text{Toskanes} = (74.4)(7.08) = 527 \text{ Toskanes.}$$

- A filter is placed under the pad for the bed material of cobbles and gravel. The d_{85} of a granular filter is 95 mm.

The distance between the pier and the west abutment is not specified in this example. If the spacing between the two protection pads is 1.5 m or less, it is recommended that the pads be joined to form a continuous pad between the abutment and the pier. Figure 6.6 shows the recommended layout of Toskane protection pads.

Information on Toskane fabrication and installation costs can be found in Fotherby and Ruff 1995 (PennDOT study).⁽⁵⁾

6.8 DESIGN EXAMPLE FOR A BRIDGE PIER (English)

A bridge over Blue Creek⁽⁵⁾ has a single pier located on the outside of a bend (Figure 6.7). The pier is round nosed and is 3.3 ft wide and 19.7 ft long. The footing is not exposed and bed material is cobbles and gravel. The average velocity directly upstream of the bridge during high flow is 8.2 ft/s and has an angle of attack of 15°.

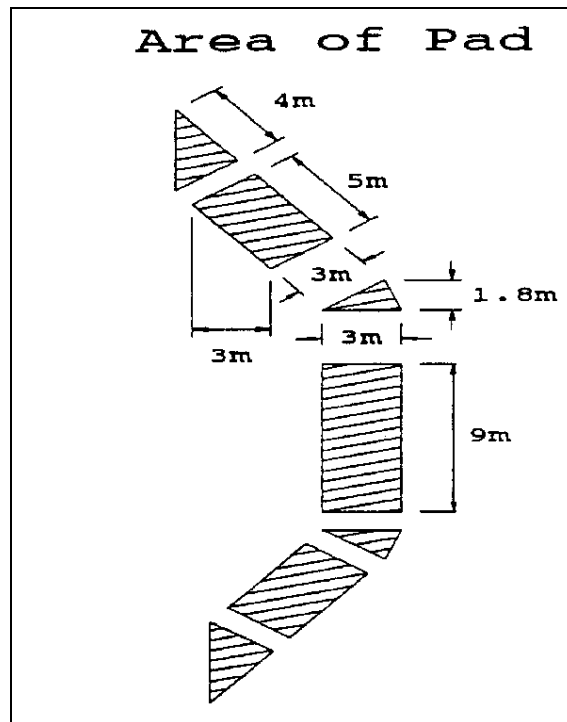

Figure 6.5. Area of abutment pad.

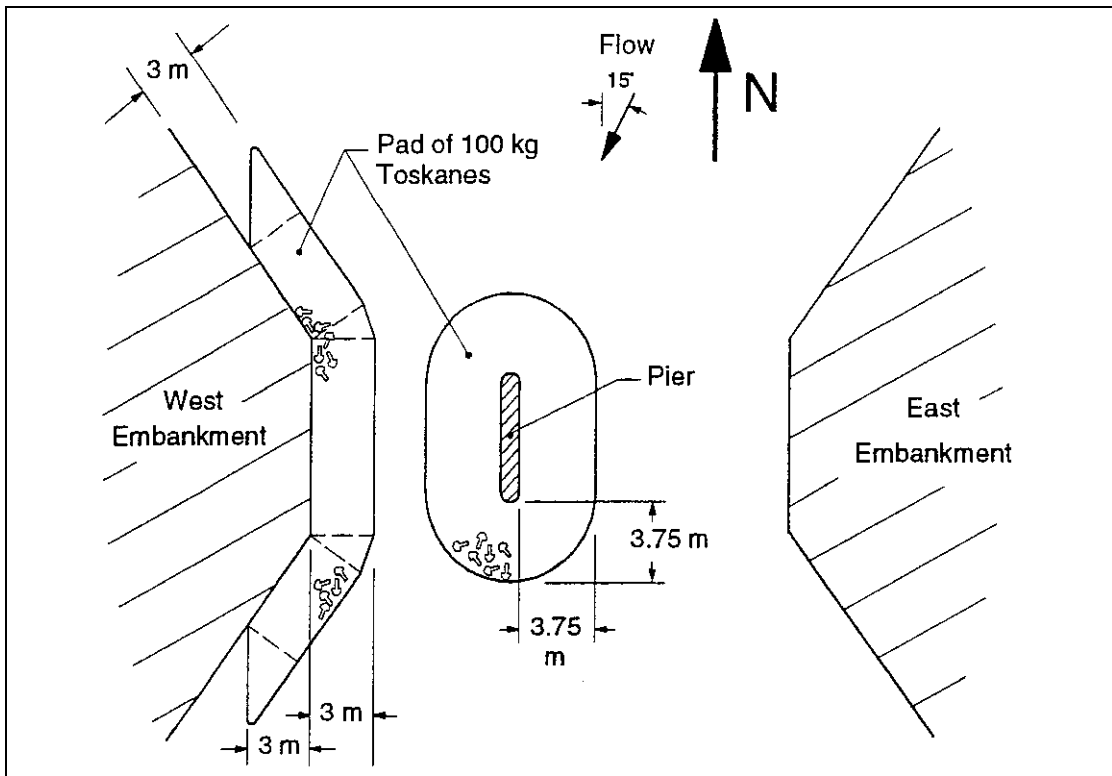

Figure 6.6. Blue Creek with Toskane protection pads.

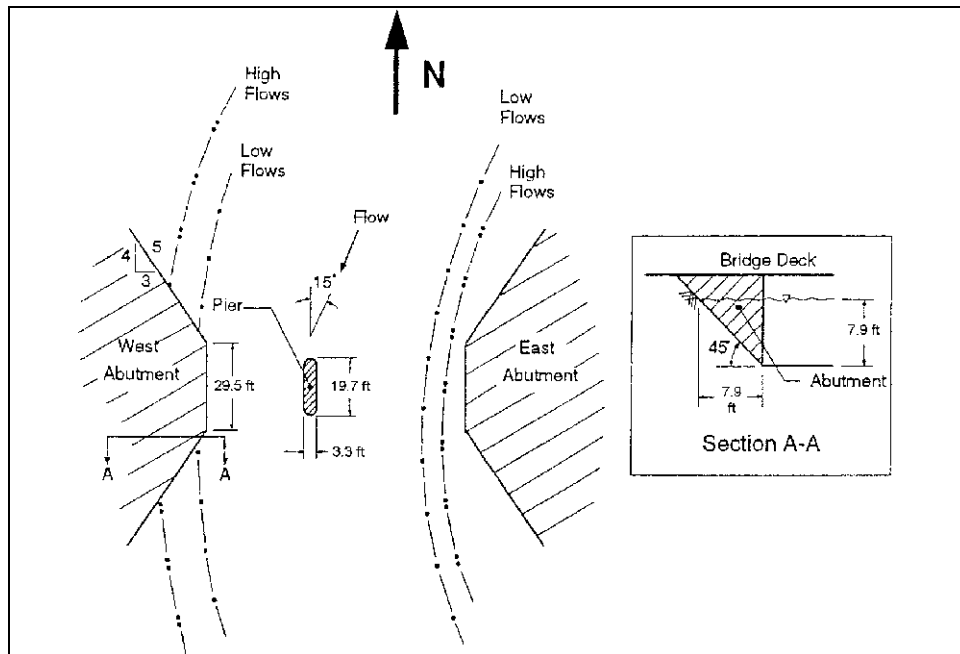

Figure 6.7. Blue Creek site.

1. Determine the velocity value, V_v (ft/s).
Because the pier is located in the thalweg of the bend, $C_i = 1.1$.
The angle of attack, $\alpha = 15^\circ > 5^\circ$, therefore $C_s = 1.0$.
The Toskane pad is installed so that the top of the pad is level with the bed, $C_h = 1.0$.
A randomly installed pad of Toskanes is selected, $C_i = 1.0$.

$$V_v = 1.5V_o C_i C_s C_h C_i$$

$$V_v = (1.5)(8.2)(1.1)(1.0)(1.0)(1.0) = 13.53 \text{ ft / s}$$

2. Calculate the adjusted structure width, b_a (ft).
The angle of attack, $\alpha = 15^\circ$.
Length of pier, $L = 19.7$ ft.
Pier width, $b = 3.3$ ft.

$$b_a = L \sin \alpha + b \cos \alpha$$

$$b_a = L \sin \alpha + b \cos \alpha = 19.7 \sin (15^\circ) + 3.3 \cos (15^\circ) = 8.3 \text{ ft}$$

3. From Equation 6.1 calculate the equivalent spherical diameter, D_u , for $V_v = 13.53$ ft/s and $b_a = 8.3$ ft ($S_g = 2.4$).

$$D_u = \frac{0.255V_v \sqrt{\frac{b_a}{g}}}{(S_g - 1)}$$

$$D_u = \frac{0.255(13.53) \sqrt{8.3 / 32.2}}{(1.4)} = 1.25 \text{ ft}$$

Using standard sizes (Table 6.2), a 250 lb Toskane unit ($D_u = 1.47$ ft) is selected. The ratio $b_a/D_u = 8.3/1.47 = 5.6 < 21$, therefore the size is acceptable.

4. Since the engineer is confident about the flow velocity and angle of attack, and the channel is not expected to experience any vertical instability, a pad radius of $\ell = 1.5b_a$ was chosen.

$$\text{Pad Radius, } \ell = 1.5(8.3) = 12.5 \text{ ft}$$

The Toskanes will be installed around the pier, a horizontal distance of 12.5 ft from the wall of the pier.

5. From Table 6.3, the number of Toskanes per unit area for the 250 lb Toskane size with a pad thickness of $2D_u$ is 0.61 Toskanes/ft². Total area of the pad (Figure 6.8) is:

$$\text{Area} = 2(16.4(12.5)) + (\pi(14.15^2 - 1.65^2)) = 1030 \text{ ft}^2$$

$$\#\text{Toskanes} = 0.61 (1030) = 629 \text{ Toskanes}$$

$$\text{The pad thickness is } 2D_u = 3 \text{ ft}$$

6. Since the bed material is cobbles and gravel, a granular filter is added beneath the pad of Toskanes. The d_{85} of the filter directly beneath the pad of Toskanes is 95 mm. The cobbles and gravel are sufficiently large so no additional filter layers are required.

6.9 DESIGN EXAMPLE FOR A BRIDGE ABUTMENT (English)

The bridge at Blue Creek⁽⁵⁾ in Figure 6.7 has vertical wall abutments with wing walls. During normal flows the west abutment extends 2 ft into the flow, but during high flows it obstructs 7.9 ft of the flow (normal to the flow field). The embankment slope is at 1H:1V. The east abutment does not obstruct the flow even during high flows.

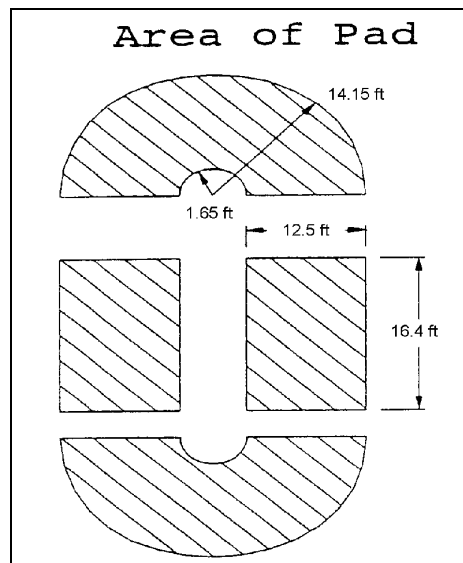

Figure 6.8. Area of pier pad.

1. Determine the velocity value, V_v (ft/s).
The abutment is located near the bank, outside of the thalweg, $C_1 = 0.9$.
Since the abutment has wing walls, $C_s = 0.85$.
The Toskane pad is installed so that the top of the pad is level with the bed, $C_h = 1.0$.
A randomly installed pad of Toskanes is selected, $C_i = 1.0$.

$$V_v = 1.5V_o C_1 C_s C_h C_i$$

$$V_v = (1.5)(8.2)(0.9)(0.85)(1.0)(1.0) = 9.41 \text{ ft/s}$$

2. Calculate the adjusted structure width, b_a (ft).

Since the west river bank has a slope of 1H:1V, an average value is used for the length of abutment that projects perpendicular to the flow. The abutment extends 7.9 ft at the water surface and 0 ft at the channel bed (Figure 6.7). Therefore an average value of:

$$b_a = \frac{7.9}{2} + 0.0 = 4.0 \text{ ft}$$

This is less than the minimum, therefore $b_a = 5 \text{ ft}$

3. From Equation 6.1 calculate the equivalent spherical diameter, D_u , for $V_v = 9.41$ ft/s and $b_a = 5$ ft.

$$D_u = \frac{0.255 V_v \sqrt{\frac{b_a}{g}}}{(S_g - 1)}$$

$$D_u = \frac{0.255 (9.41) \sqrt{5.0 / 32.2}}{(1.4)} = 0.68 \text{ ft}$$

For the west abutment, the 250 lb Toskane is selected ($D_u = 1.47$ ft). A smaller 125 lb Toskane could have been selected, but this non-standard size may not be economical to manufacture.

4. Since the engineer is confident about the flow velocity and the channel is assumed vertically stable, a pad radius of $\ell = 2.0b_a$ is recommended.

$$\text{Pad Radius, } \ell = 2.0(5.0) = 10 \text{ ft}$$

The Toskanes will be installed along the abutment and wingwalls a horizontal distance of 10 ft from the wall.

5. The pad thickness is $2D_u$ which will result in 0.61 Toskanes/ft². The total area of the pad (Figure 6.9) is:

$$\text{Area} = (10)(29.5) + 2(10)(16.4) + 2(0.5)(10)(5.9) + 2(0.5)(10)(13.1) = 813 \text{ ft}^2$$

$$\# \text{Toskanes} = (813)(0.61) = 496 \text{ Toskanes.}$$

6. A filter is placed under the pad for the bed material of cobbles and gravel. The d_{85} of a granular filter is 95 mm.

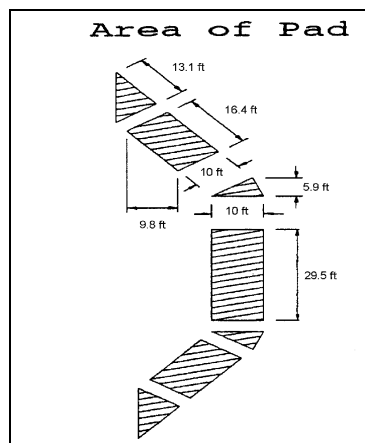

Figure 6.9. Area of abutment pad.

The distance between the pier and the west abutment is not specified in this example. If the spacing between the two protection pads is 5 ft or less, it is recommended that the pads be joined to form a continuous pad between the abutment and the pier. Figure 6.10 shows the recommended layout of Toskane protection pads.

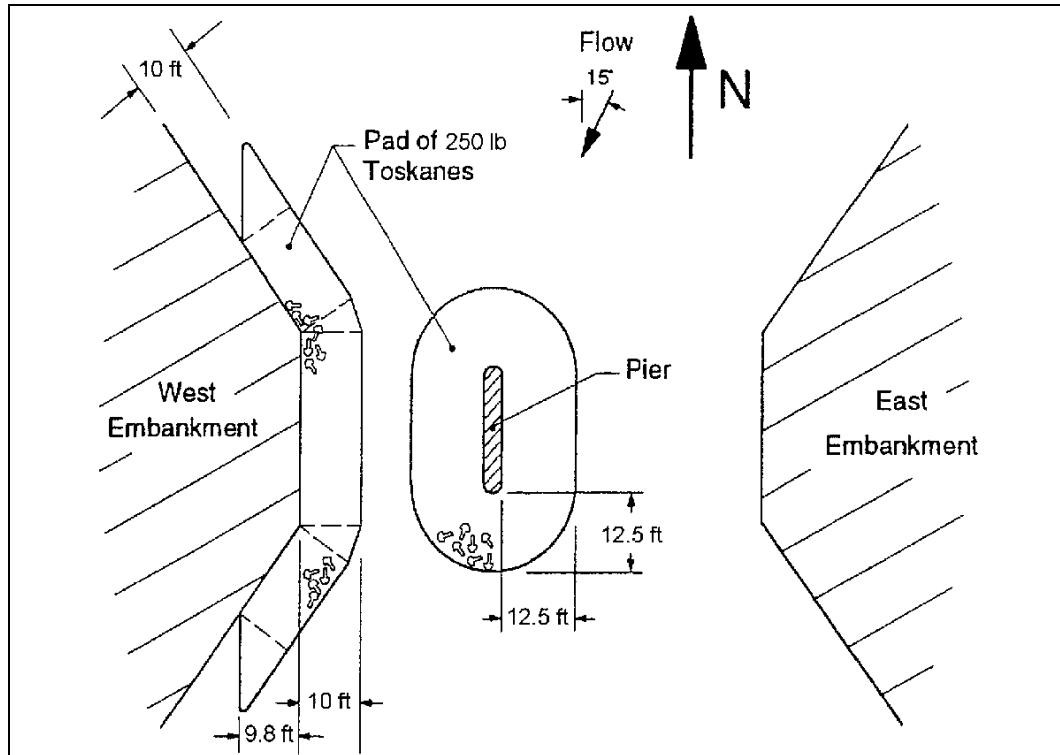

Figure 6.10. Blue Creek with Toskane protection pads.

Information on Toskane fabrication and installation costs can be found in Fotherby and Ruff 1995 (PennDOT study).⁽⁵⁾

6.10 A-Jacks® DESIGN PROCEDURE FOR PIER SCOUR PROTECTION

6.10.1 Background

The discrete particle design approach illustrated by the Toskane design guidelines concentrates on the size, shape, and weight of individual armor units, whether randomly placed or in stacked or interlocked configurations. In contrast, the basic construction element of A-Jacks for pier scour applications is a "module" comprised of a minimum of 14 individual A-Jacks banded together in a densely-interlocked cluster, described as a 5x4x5 module. The banded module thus forms the individual design element. Figure 6.11 illustrates the concept. (Note that the photograph of Figure 6.11 shows that a module larger than 5x4x5 can be configured).

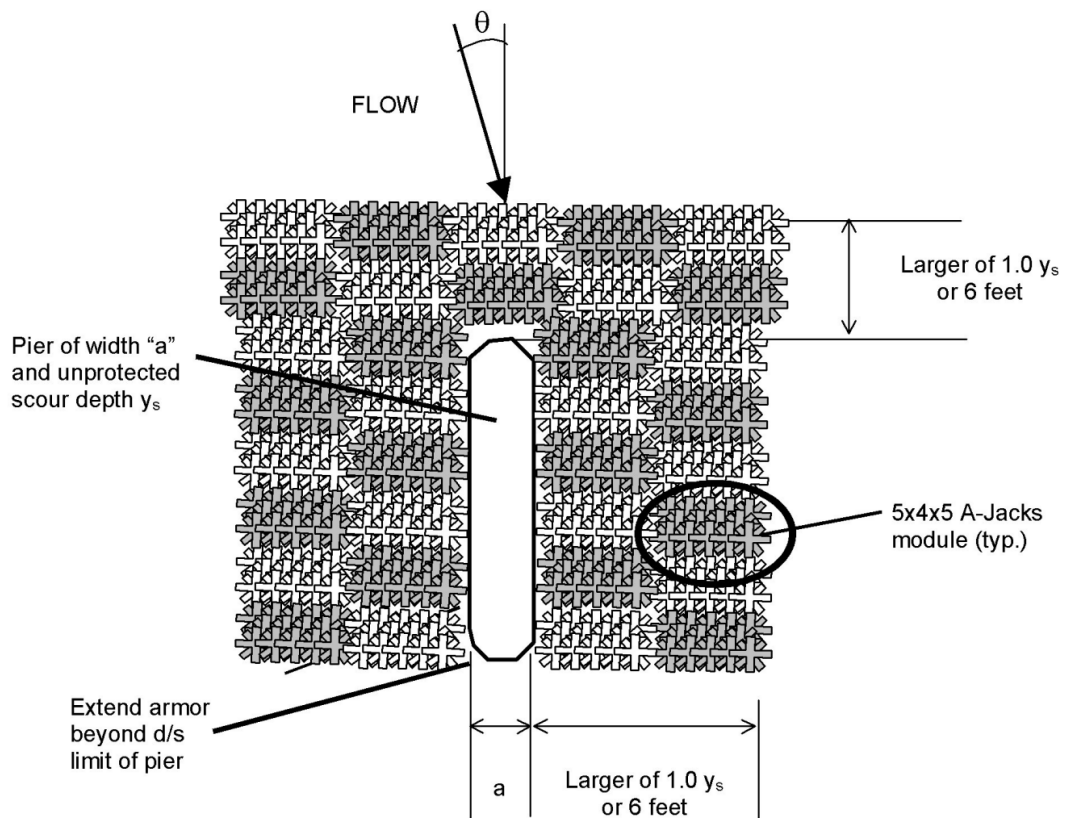

Note: For skew angle θ greater than 15 degrees, increase the above dimensions by $1/\cos\theta$.

Figure 6.11. A-Jacks modules for pier scour protection.

In late 1998 and early 1999, a series of 54 tests of 6-inch model scale A-Jacks was conducted at Colorado State University (CSU) to examine their effectiveness in pier scour applications. This program is described in detail in CSU's test report entitled, "Laboratory Testing of A-Jacks Units for Inland Applications: Pier Scour Protection Testing."^(9,10)

The CSU tests were conducted in an 8-foot (2.44 m) wide indoor flume with a sand bed, and examined a variety of conditions, including no protection (baseline conditions), banded 5x4x5 modules arrayed in several different configurations, and individual (unbanded) A-Jacks armor units. Both round and square piers were used in the program. The results indicated that, when used in combination with a bedding layer (either granular bedding stone or a properly selected geotextile), the A-Jacks 5x4x5 modules reduced scour at the pier from 70 percent to more than 95 percent (scour depths were from 30 percent to less than 5 percent of that in the unprotected baseline condition).

6.10.2 Design Guidelines

Hydraulic stability of a 5x4x5 A-Jacks module can be estimated by setting the overturning moment due to the total drag force equal to the resisting moment due to the submerged weight of the module:

$$F_d H_d = W_s L_w \quad (6.4)$$

where:

- F_d = drag force, equal to $0.5C_d\rho AV^2$, N (lb)
- C_d = drag coefficient (dimensionless)
- ρ = density of water, kg/m^3
- A = frontal area of A-Jacks module, m^2 (ft^2)
- V = flow velocity immediately upstream of A-Jacks module, m/s (ft/s)
- H_d = moment arm through which the drag force acts, m (ft)
- W_s = submerged weight of A-Jacks module, N (lb)
- L_w = moment arm through which the submerged weight acts, m (ft)

As a first estimate, the coefficient of drag C_d on an A-Jacks module can be assumed to be similar to that of a disc oriented normal to the flow velocity, with flow occurring over the top and around the sides. This value is approximately 1.2⁽¹¹⁾. A conservative estimate for the location of the drag force would place it at the full height of the module, providing the greatest moment arm for overturning.

Tests were conducted at CSU in a steep (13 percent slope), fixed-bed flume to determine the hydraulic stability of the 5x4x5 A-Jacks modules in a typical pier scour configuration. Discharge was gradually increased until overturning of the module was achieved. Both submerged and unsubmerged conditions were examined.

Measuring hydraulic conditions at the threshold of overturning allows both the coefficient of drag, C_d , and the height of the drag force, H_d , to be determined directly from measured data. The other variables in Equation 6.4 are determined from the physical characteristics of the 5x4x5 A-Jacks module.

Using a drag coefficient C_d of 1.05 for the A-Jacks modules from the laboratory testing, and assuming that the drag force acts at the full height the module, the hydraulic stability of prototype scale A-Jacks modules can be determined. Table 6.4 provides the results of this hydraulic stability analysis.⁽¹²⁾

A-Jacks System	Tip-to-Tip Dimension of Armor Unit (in)	Module Dimensions (HxWxL) (in)	Weight (or Mass) in Air, lbs (kg)	Submerged Weight (or Mass, lbs (kg)	Limiting Upstream Velocity, ft/s (m/s)
AJ-24	24	16 x 52 x 40	1,030 (467)	540 (245)	10.7 (3.3)
AJ-48	48	32 x 104 x 80	8,270 (375)	4,300 (1,950)	15.1 (4.6)
AJ-72	72	48 x 156 x 120	27,900 (12,655)	14,500 (6,577)	18.5 (5.6)
AJ-96	96	64 x 208 x 160	66,200 (30,028)	34,400 (15,604)	21.4 (6.5)

Notes:

1. Volume of concrete in ft^3 for a 14-unit module is $14 \times 0.071 \times L^3$ where L is tip-to-tip dimension of armor unit in feet.
2. Values in table assume a unit weight (or mass) of 130 lbs/ft^3 ($2,083 \text{ kg/m}^3$) for concrete.

6.10.3 Layout and Installation

Geometry. The movable-bed tests conducted at CSU indicate that a chevron-style A-Jacks placement around a bridge pier does not improve performance beyond that afforded by simple rectangular geometries. As the rectangular shape accommodates the basic 5x4x5 A-Jacks module design unit, this geometry provides the recommended style for layout and placement of the armor units. Figure 6.11 provides recommended minimum dimensions for the placement of modules around a pier of width "a" and having an unprotected depth of scour y_s as determined by HEC-18.⁽⁷⁾

It should be noted that the CSU stability tests were conducted on a fully-exposed module; partial burial will result in a more stable installation. Also, the orientation of the modules in the stability tests exposed the maximum frontal profile to the flow (i.e., long axis perpendicular to the flow direction). Placement of the modules with the long axis parallel to the flow will result in a more stable arrangement than indicated by the recommended values in Table 6.4.

A-Jacks Placement. A-Jacks modules can be constructed onsite in the dry and banded together in 5x4x5 clusters in place around the pier, after suitable bedding layers have been placed. Alternatively, the modules can be pre-assembled and installed with a crane and spreader bar; this arrangement may be more practical for placement in or under water.

Bands should be comprised of cables made of UV-stabilized polyester, galvanized steel, or stainless steel, as appropriate for the particular application. Crimps and stops should conform to manufacturer's specifications. When lifting the modules with a crane and spreader bar, all components of the banding arrangement should maintain a minimum factor of safety of 5.0 for lifting.

Where practicable, burial or infilling of the modules to half-height is recommended so that the voids between the legs are filled with appropriate sized stone. Stone sizing recommendations are provided in the next section.

Bedding Considerations. The movable-bed tests conducted at CSU indicate that a bedding layer of stone, geotextile fabric, or both, should be included as part of the overall design of an A-Jacks installation. The purpose of a bedding layer is to retain the finer fraction of native bed material that could otherwise be pumped out between the legs of the A-Jacks armor units.

When bedding stone is placed directly on the streambed material at a pier, it must meet certain size and gradation requirements to ensure that it not only retains the bed material, but that it is permeable enough to relieve potential pore pressure buildup beneath the installation. In addition, the size of the bedding stone must be large enough to resist being plucked out through the legs of the A-Jacks by turbulent vortices and dynamic pressure fluctuations. In some cases, two or more individual layers of bedding stone, graded from finer in the lower layers to coarsest at the streambed, must be used to satisfy all the criteria. Figures 6.12a and 6.12b illustrate the bedding options discussed in this section.

Recommended sizing criteria for bedding stone⁽¹³⁾ are as follows:

$$\begin{array}{l}
 \text{Retention: } D_{85(\text{Lower})} > 0.25D_{15(\text{Upper})} \\
 \phantom{\text{Retention: }} D_{50(\text{Lower})} > 0.14D_{50(\text{Upper})} \\
 \text{Permeability: } D_{15(\text{Lower})} > 0.14D_{15(\text{Upper})} \\
 \text{Uniformity: } D_{10(\text{Upper})} > 0.10D_{60(\text{Upper})}
 \end{array}$$

In the above relations, D_x is the particle size for which x percent by weight are finer, and the designations Upper and Lower denote the respective positions of various granular bedding layers in the case when multiple layers are used. Each layer should be at least 6 to 8 inches (152 to 203 mm) thick, with the exception of uppermost layer which should be thicker, in accordance with Table 6.5. Note that the lowest layer of the system corresponds to the native streambed material.

A-Jacks System	D_{50} Size of Uppermost Layer, in (mm)	Recommended Minimum Thickness of Uppermost Layer, in (mm)
AJ-24	2-3 (50-75)	8 (200)
AJ-48	4-6 (100-150)	12 (300)
AJ-72	6-9 (150-225)	24 (600)
AJ-96	8-12 (200-300)	30 (750)

In lieu of multiple layers of granular bedding, it is often desirable to select a geotextile which is compatible with the native streambed material. However, placement of a geotextile may not always be practical, particularly when installing the system under flowing water. If a geotextile is used, it is recommended that a layer of ballast stone, with characteristics in accordance with Table 6.5, be placed on top prior to installing the A-Jacks modules.

When a geotextile is used, selection criteria typically require that the fabric exhibit a permeability at least 10 times that of the native streambed material to prevent uplift pressures from developing beneath the geotextile. In addition, the Apparent Opening Size (AOS) of the apertures of the geotextile should typically retain at least 30 percent, but not more than 70 percent, of the grain sizes present in the bed. Selected references for determining geotextile properties are provided in Design Guideline 12. Finally, the geotextile must be strong enough to survive the stresses encountered during placement of stone and armor units.

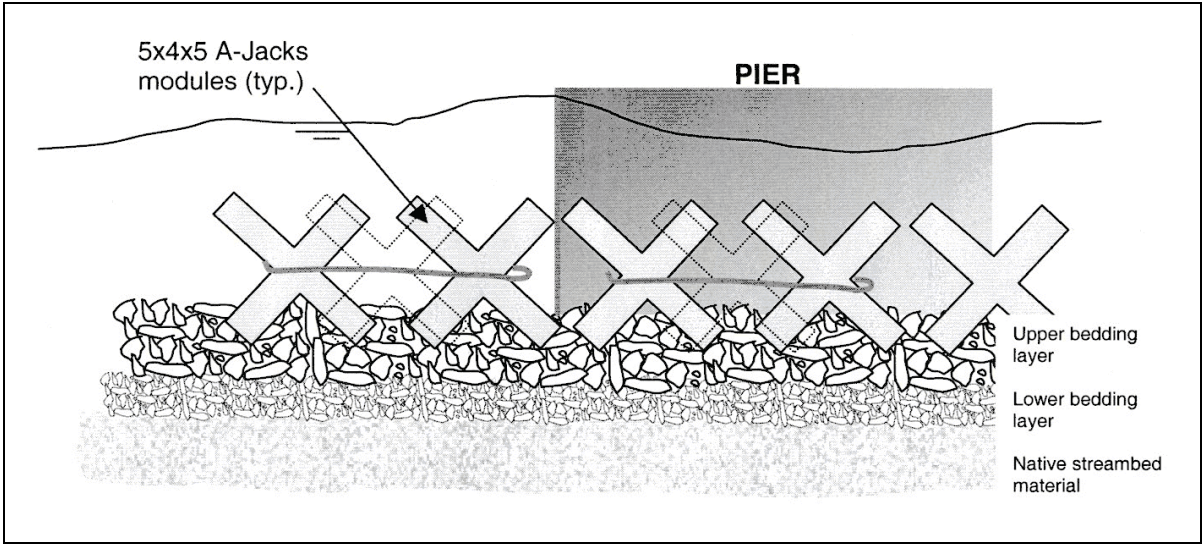

Figure 6.12a. Bedding detail showing two layers of granular bedding stone above native streambed material.⁽¹²⁾

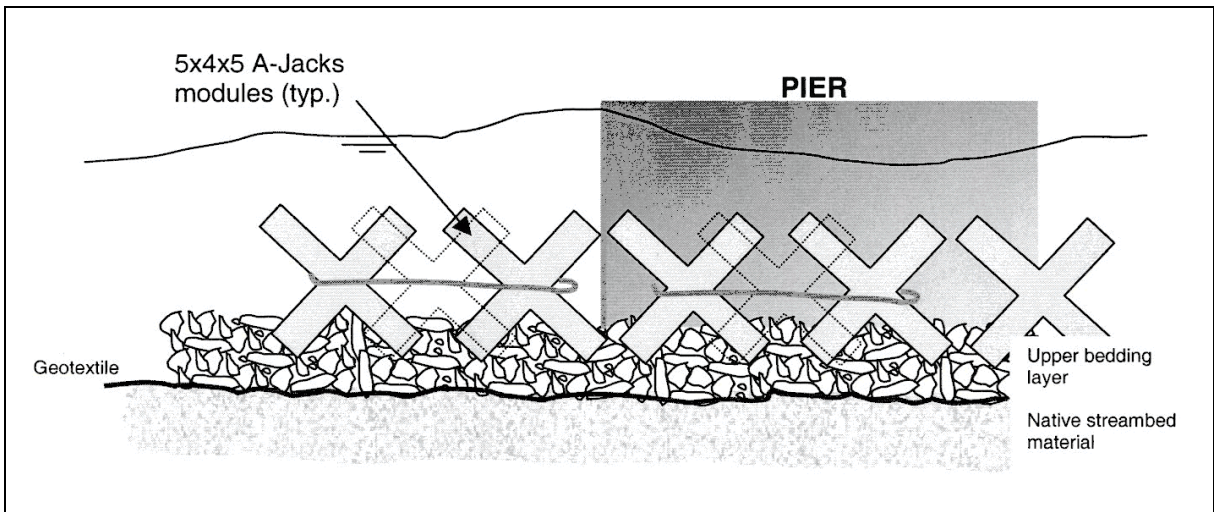

Figure 6.12b. Bedding detail showing ballast stone on top of geotextile.⁽¹²⁾

Limited field testing using a design layout similar to Figure 6.11 and the guidelines of this section has been conducted. Figures 6.13 a, b, and c show a demonstration site installation of A-Jacks for pier scour protection in Kentucky.

6.11 REFERENCES

1. Parola, A.C., 1993, "Stability of Riprap at Bridge Piers," *Journal of Hydraulic Engineering*, ASCE, Vol. 119, No.10.
2. Fotherby, L.M. and J.F. Ruff, 1996, "Riprap and Concrete Armor to Prevent Pier Scour," *Hydraulic Engineering 1996*, Session BS-20, Proceedings of 1996 Conference sponsored by the Hydraulics Division of the ASCE.
3. Bertoldi, D.A., J.S. Jones, S.M. Stein, R.T. Kilgore, and A.T. Atayee, 1996, "An Experimental Study of Scour Protection Alternatives at Bridge Piers," U.S. Federal Highway Administration Publication No. FHWA-RD-95-187.
4. Brown, S.A. and E.S. Clyde, 1989, "Design of Riprap Revetment," Hydraulic Engineering Circular No. 11, FHWA-IP-016, prepared for FHWA, Washington, D.C.
5. Fotherby, L.M. and J.F. Ruff, 1995, "Bridge Scour Protection System Using Toskanes - Phase 1," Pennsylvania Department of Transportation, Report 91-02.
6. Fotherby, L.M., 1995, "Scour Protection at Bridge Piers: Riprap and Concrete Armor Units," Dissertation, Colorado State University, Fort Collins, CO.
7. Richardson, E.V. and S.R. Davis, 2001, "Evaluating Scour at Bridges," Fourth Edition Report, FHWA NHI 01-004, Federal Highway Administration, Hydraulic Engineering Circular No. 18, U.S. Department of Transportation, Washington, D.C.
8. Holtz, D.H., B.R. Christopher, and R.R. Berg, 1995, "Geosynthetic Design and Construction Guidelines," National Highway Institute, Publication No. FHWA HI-95-038, Federal Highway Administration, Washington D.C., May.
9. Thornton, C.I., C.C. Watson, S.R. Abt, C.M. Lipscomb, and C.M. Ullman, 1999, "Laboratory Testing of A-Jacks Units for Inland Applications: Pier Scour Protection Testing," Colorado State University research report for Armortec Inc., February.
10. Thornton, C.I., C.C. Watson, S.R. Abt, C.M. Lipscomb, C.L. Holmquist-Johnson, and C.M. Ullman, 1999, "Laboratory Testing of A-Jacks Units for Inland Applications: Full Scale Testing," Colorado State University research report for Armortec Inc., February.
11. Vennard, J.K. and R.L. Street, 1975, "Elementary Fluid Mechanics," John Wiley & Sons, New York, NY.
12. Clopper, P.E. and M.S. Byars, 1999, "A-Jacks Concrete Armor Units Channel Lining and Pier Scour Design Manual," prepared by Ayres Associates for Armortec, Inc., Bowling Green, KY, July.
13. Escarameia, M., 1998, "River and Channel Revetments: A Design Manual," Thomas Telford Publications, London.



Figure 6.13a. Scour hole debris at Bridge 133, Graves County, KY



Figure 6.13b. Newly-installed A-Jacks armor units at Bridge 133, Graves County, KY



Figure 6.13c. Close-up of armor units after several flow events at Bridge 133, Graves County, KY

(page intentionally left blank)

DESIGN GUIDELINE 7
GROUT/CEMENT FILLED BAGS

(page intentionally left blank)

DESIGN GUIDELINE 7

GROUT/CEMENT FILLED BAGS

7.1 INTRODUCTION

Grout/cement filled bags have been used to protect stream banks in areas where riprap of suitable size and quality is not available at a reasonable cost. Guidelines for the use of bags (sacks) as a streambank revetment can be found in HDS 6⁽¹⁾ and Keown.⁽²⁾ Grout/cement filled bags have also been used as a countermeasure against scour at bridges. Historically they have been used to fill in undermined areas around bridge piers and abutments. As scour awareness increases, grout filled bags are being used to armor channels where scour is anticipated or where scour is detected. Whether they are implemented in a post- or pre-scour mode, grout bags are relatively easy to install and can shift to changes in the channel bed to provide effective scour protection.

7.2 DESIGN GUIDELINES

A precise quantitative factor of safety design procedure is not normally completed for the design of grout filled bags. This type of design would be beneficial in determining the hydraulic stability of the bags, but historically this has not been done for grout filled bags. It would require a comparison of the hydraulic shear stress and the critical shear stress to uplift the grout bag as is done with riprap using discrete particle analysis. Information on hydraulic performance of grout bags at bridge piers can be found in Bertoldi⁽³⁾ and Fotherby.⁽⁴⁾ More often, engineering judgment is used to select a bag size that will not be removed by the flow. Installation practices are critical to the success of the system. Guidelines for the use of grout filled bags for bridge scour reflect information provided by the Maryland State Highway Administration (MDSHA).⁽⁵⁾

7.3 TIPS FOR CONCRETE BAG INSTALLATION (MDSHA): (see attached **Sheets 1 - 10**)

1. It is preferable to place a single layer of bags instead of stacking. Filter Fabric should be placed under single layered bags that have the potential to settle away from each other. Guidelines on the selection and design of filter material can be found in HEC-11⁽⁶⁾ and Holtz et al. (FHWA HI-95-038).⁽⁷⁾
2. If bags are stacked, overlap the joints of the preceding layer.
3. If possible, bags should be buried so that the top of the bag is at or below the stream bottom (see Sheet 3 of 10). When filling a scour hole, keep the top of the bag at or below the stream bottom, if possible (see Sheet 5 of 10).
4. Do not tie bags together with reinforcing steel or by any other means. Allow bags to settle to a state of equilibrium individually. (This differs from specifications recommended by the State of Maine where stitching bags together is a recommended procedure for protection of undermined areas at piers.)
5. Excessively large bags, one side greater than 4.6 m (15 ft), are more susceptible to undermining because they do not tend to settle or shift into place as scour develops.

6. Small bags, no side greater than 1.5 m (5 ft) , tend to settle and conform to the bottom.
7. The bag placed directly in front of the nose of the pier should be the width of the exposed portion of the pier (see Sheets 8 and 10 of 10). This is the area with the greatest turbulence. Overlapping of bags is important here. Any open gaps between bags can allow sediment under the bags to be eroded causing undermining of the bags. Geotextile fabric at this location would also help eliminate the possibility of undermining. Similarly, no gaps should be allowed to form between the bags and the front face of the footing.
8. The concrete bags should cover the stream bottom around the pier for a distance of 1.5 times the width of the exposed portion of the pier or a minimum of 1.8 m (6 ft) whichever is greater.
9. Use a cutoff wall along the entrance and trail end of the concrete bags that extend across the entire stream channel, if possible.
10. Where there is a potential for continued scour along newly installed concrete bags in a wide stream channel, use a cutoff wall or a fabric hinge to protect the bags against undermining.

7.4 CONCRETE BAG INSTALLATION AND GROUTING OF UNDERMINED AREA AT PIERS AND ABUTMENTS (MDSA): (Sheets 2 and 6 of 10)

1. Depending on the depth of the undermining, place one concrete bag or stack several layers of concrete bags along the face of the abutment or pier in front of the undermined area
2. Once the vent/fill pipes have been installed and the bags are filled , pump the grout into the undermined area. Cut the vent/fill pipes flush with the top of the bags after the pumping operation is complete. Debris could get caught up on these pipes and cause additional scour if left exposed.
3. Adequate venting of the water to be displaced in the undermined area is important. The water must be able to escape as it is displaced by the grout pumped into the cavity. A 1.2 m (4 ft) maximum spacing of the vent/fill pipes is recommended.
4. It is important to keep the nozzle buried in the grout during pumping. This is to reduce the amount of mixing of the grout and the water to be displaced.
5. Debonding jackets should be placed around piles to prevent the grout from adhering to the piles if the added weight from the grout would cause a significant reduction in the pile capacity.
6. If possible, clean out unstable material along the bottom of the undermined area prior to filling with grout. This would reduce the amount of loose sediment discharged through the vent pipes.
7. Pumping grout in the undermined area under a footing is not an underpinning for the footing. This is done only to fill the void area and stop the fill material located behind the footing from settling into the void area resulting in settlement of the roadway behind the structure.

7.5 SPECIFICATIONS (MDSHA)

Grout:

Portland cement concrete shall consist of nine bags, 55.8 kg/m³ (94 lb per cubic yard) Type II Portland cement, air entrainment, 6 ± 1 percent mortar sand aggregate, and water so proportioned to provide a pumpable mixture. The 28 day minimum day strength shall be 24, 140 kPa (3500 psi).

Bags:

Fabric bags shall be made of high strength water permeable fabric of nylon or cordura. Each bag shall be provided with a self closing inlet valve, to accommodate insertion of the concrete hose. A minimum of two valves shall be provided for bags more than 6.1 m (20 ft) long. Seams shall be folded and double stitched.

Dowels:

Reinforcing steel dowels, if specified on the plans, shall conform to ASTM A 615, Grade 60 and shall be epoxy coated.

Fabric:

Fabric shall exhibit the following properties in both warp and fill directions:

Tensile Strength, min.	70 kN/m	(400lb/in)	ASTM D 1682, Grab Method
Tear Strength, min.	400 N	(90 lb)	ASTM D 2262, Tongue Method

Construction:

The bags shall be positioned and filled so that they abut tightly to each other and to the substructure units. Joints between bags in successive tiers shall be staggered.

Fabric porosity is essential to the successful execution of this work. Suitability of fabric design shall be demonstrated by injecting the proposed mortar mix into three 610 mm (2 ft) long by approximately 150 mm (6 in) diameter fabric sleeves under a pressure of not more than 103 kPa (15 psi) which shall be maintained for not more than 10 minutes. A 300 mm (12 in) long test cylinder shall be cut from the middle of each cured test specimen and tested in accordance with ASTM C 39. The average seven day test compressive strength of the fabric form shall be at least higher than that of companion test cylinders made in accordance with ASTM C 31.

Standoffs to provide a uniform cross section shall be used.

Ready mixed high strength mortar may be permitted by written permission of the Engineer. The ready mixed high strength mortar shall be furnished by a manufacturer approved by the Laboratory and the plan, equipment, etc., shall be subject to inspection and approval.

The concrete pump shall be capable of delivering up to 19 m³/hr (25 yd³/hr).

7.6 SUPPLEMENTAL OBSERVATIONS ON GROUT BAGS (MDSHA)

7.6.1 Design of Bags

Bags should be designed and constructed as flat mats, 0.9 m to 1.2 m (3 to 4 feet) wide and about 0.3 m (1 foot) thick. The bag lengths should be on the order of 1.2 m to 2.4 m (4 to 8 feet). Bags should not be filled to the point that they look like stuffed sausages, since they will be much more vulnerable to undermining and movement, and will not fit properly into the mat.

Both the designer and the installer should understand how the mat is expected to perform. Each bag should be independent of other bags so that it is free to move; however, the bag should be snugly butted against adjoining bags to minimize gaps in the mat. This concept will result in a semi-flexible mat that will be able to adjust to a degree to changes in the channel bed. The mat should not be constructed as a rigid monolithic structure. It would be helpful to have a pre-construction conference with the designer, contractor and the State inspector.

The bags should be sized and located in accordance with the SHA Standards for the particular type of foundation and condition of scour. It is recommended that the type of grout bag installation and its design be reviewed by an engineer with experience in evaluating scour at bridges.

7.6.2 Installation

Careful attention should be given to preparation of the bed on which the bags are to be placed. **Where the bed is uneven, such as might occur in scour holes, best results will be obtained by planning for a sequence of placement of the bags so that each bag adds to the support of the other bags.** This is particularly important in locations where several layers of bags are to be placed. It is unlikely that detailed plans will be developed for such locations, and the integrity of the installation will depend on the skill of the persons placing the mat. If the bed is highly irregular, appropriate modification of the bed and removal of obstacles should be accomplished prior to placement of the bags.

Each bag should butt up firmly against its neighbor to provide a tight seal and to minimize the occurrence of gaps between bags. Particular attention should be given to obtaining this tight seal between the foundation and the first row of bags.

For piers, the bags should extend to a distance of 1.5 to 2 times the pier width on both sides as well as upstream of the pier nose and downstream of the pier end.

For abutments, the best results are obtained for most locations by placing the bags the full length along the upstream wingwall, abutment backwall and downstream wingwall to form a solid mat. As an interim guide, the mat width for abutments is recommended to be on the order of 1.8 m to 2.4 m (6 to 8 feet), depending upon the particular site conditions. This arrangement provides for a smooth streamlined design that locates the ends of the mat away from the main stream current or thalweg. Of course, there are a wide variation of conditions at abutments and each location needs to be designed for the site conditions.

In some cases, it may be necessary to provide for both grout bags and rock riprap to provide the desired degree of scour protection. As a general rule, however, it is preferable to provide either riprap or grout bags but not both at any one pier or abutment.

For small structures such as bridges or "bottomless" culverts with spans in the range of 4.6 m to 7.6 m (15 to 25 feet), there are essentially two choices for the design of the bags:

- Place the bags full width under the structure.
- Place the bags along each abutment/wingwall, leaving the center of the channel unprotected.

If the center channel is unprotected, it can be expected to scour as the bed degrades or large dunes migrate past the protective pad. This may result in undermining and displacement of the bags next to the channel or possibly of the whole installation. As an interim guide, it is suggested that consideration be given to lining the entire channel if more than half of the channel would be covered by grout bags placed along the abutments. **If the bags extend across the entire channel, attention needs to be given to the treatment of the upstream and downstream ends of the bag to avoid undermining and displacement.**

7.6.3 Filter Cloth

The following interim guidance is provided with regard to use of filter cloth:

Filter cloth should generally be used at locations where the bags are placed in a single layer along a level plane on the channel bed or flood plain. The filter cloth provides for additional support and stability in the event that the bags are subjected to undermining or movement as a result of scouring and hydraulic forces.

Where grout bags are placed in layers in a trenched condition, such as might occur in a scour hole, there is probably less need to provide for the filter cloth. At this point, however, it is recommended that the decision to eliminate filter cloth be made on a case by case basis. **The general rule should be to place filter cloth under the grout bags unless:**⁽³⁾

1. Multiple layers are carefully placed to cover spaces between bags in the bottom layer
2. Bags are stitched together and the bag fabric is durable enough to serve as a filter, or
3. Bags are poured in large masses such as might be used to fill a scour hole

7.6.4 Undermined Foundations

Grout bags provide for an efficient, cost effective means of underpinning foundations that have been scoured down below the bottom of the footing. General guidance on placement of bags and procedures for grouting the voids under the footing has been developed by MSHA in standard drawings.

7.6.5 Appearance

If grout bags are placed under water, they are barely noticeable. A well designed and installed grout bag mat exposed to view under a bridge can be expected to have a streamlined and pleasing appearance. At some sites, the mats become covered with silt and

are barely distinguishable from the channel banks or bed. Grout bags placed along wingwalls are usually exposed to the sun. Bags in these locations are likely to be covered by vegetation, especially when they have been covered by silt during high water events. There were a few sites visited where the bags had an ungainly appearance. In most cases, these were bags that were pumped so full that they looked like sausages. Other reasons for a poor appearance include inadequate attention to design, installation, preparation of the bed on which the mat is placed, or a combination of these factors.

Early installations included bags with lengths of 4.6 m (15 feet) or more. In some cases, the bags were too long to fit properly into a compact mat. Use of shorter bags should help to minimize this problem in future installations.

7.7. MAINE DOT GUIDELINES

Specifications for grout bags for undermined areas at piers were also provided by the State of Maine Department of Transportation⁽⁸⁾ as follows:

The underwater grout bags shall be fabricated based on the dimensions of the existing voids to be filled. Bags should be on the order of 0.9 m to 1.2 m (3 to 4 ft) wide and 1.8 to 2.4 m (6 to 8 ft) long. Bags shall be securely placed to form a perimeter bulkhead to partially fill and enclose the substructure void. Grout shall be pumped to uniformly fill the secured bag with sufficient restraint so as to not rupture the bag. Consecutive bag placement shall be in accordance with the manufacturer's requirements. At a minimum this will require: placement of reinforcing bar between successive layers, stitching together adjacent bags with an overlapping splice (where accessible), and covering holes left by grout and other inserts.

NOTE: The State of Maine recommends stitching bags together for protection of undermined areas at piers. This procedure conflicts with the guideline provided by the State of Maryland in Section 7.3, Item 4.

7.8 REFERENCES

1. Richardson, E.V., D.B. Simons, and P.F. Lagasse, 2001, "River Engineering for Highway Encroachments - Highways in the River Environment," Report FHWA NHI 01-004, Federal Highway Administration, Hydraulic Design Series No. 6, Washington, D.C.
2. Keown, M.P., 1983, "Streambank Protection Guidelines for Landowners and Local Governments," U.S. Army Corps of Engineers, Waterways Experiment Station, Vicksburg, MS.
3. Bertoldi, D.A., S.J. Jones, S.M. Stein, R.T. Kilgore, and A.T. Atayee, 1996, "An Experimental Study of Scour Protection Alternatives at Bridge Piers," FHWA-RD-95-187, Office of Engineering and Highway Operations R&D, McLean, VA.
4. Fotherby, L.M., 1997, "Footings, Mats, Grout Bags, and Tetrapods, Protection Method Against Local Scour at Bridge Piers," M.S. Thesis, Colorado State University.
5. Maryland State Highway Administration, 1993, "Bridge Scour Notebook Supplement No. 1," MDSHA Office of Bridge Development, Bridge Hydraulics Unit, May.

6. Brown, S.A. and E.S. Clyde, 1989, "Design of Riprap Revetment," Hydraulic Engineering Circular No. 11, FHWA-IP-016, prepared for FHWA, Washington, D.C.
7. Holtz, D.H., B.R. Christopher, and R.R. Berg, 1995, "Geosynthetic Design and Construction Guidelines," National Highway Institute, Publication No. FHWA HI-95-038, Federal Highway Administration, Washington D.C., May.
8. State of Maine Department of Transportation, 1995, "Supplemental Specifications for Underwater Grout Bags," Section 502, April.

7.9 CONTACT

Maryland State Highway Administration
Office of Bridge Development
707 North Calvert Street
Baltimore, Maryland 21202

(page intentionally left blank)

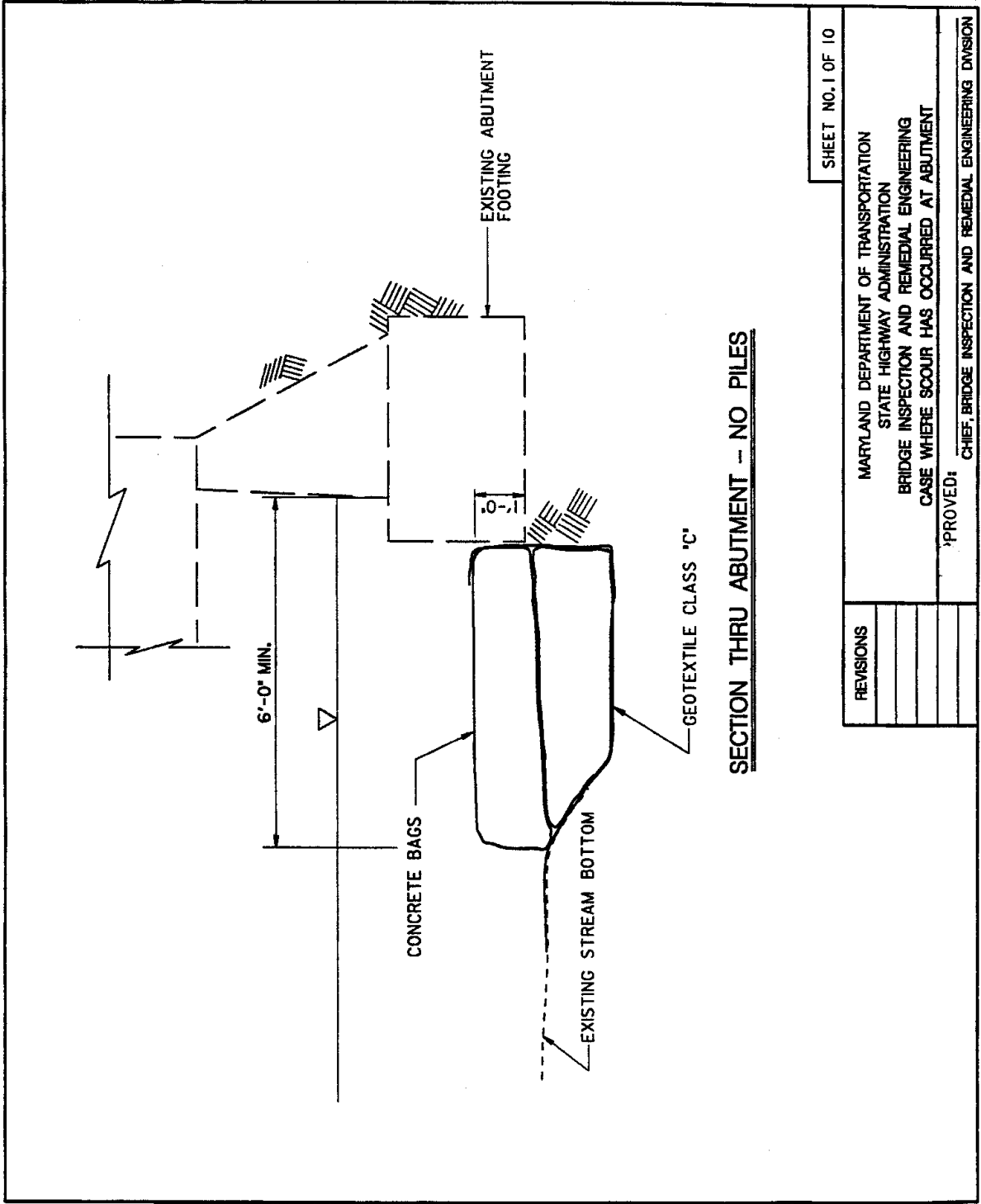

SECTION THRU ABUTMENT -- NO PILES

REVISIONS	SHEET NO. 1 OF 10 MARYLAND DEPARTMENT OF TRANSPORTATION STATE HIGHWAY ADMINISTRATION BRIDGE INSPECTION AND REMEDIAL ENGINEERING CASE WHERE SCOUR HAS OCCURRED AT ABUTMENT APPROVED: CHIEF, BRIDGE INSPECTION AND REMEDIAL ENGINEERING DIVISION

(page intentionally left blank)

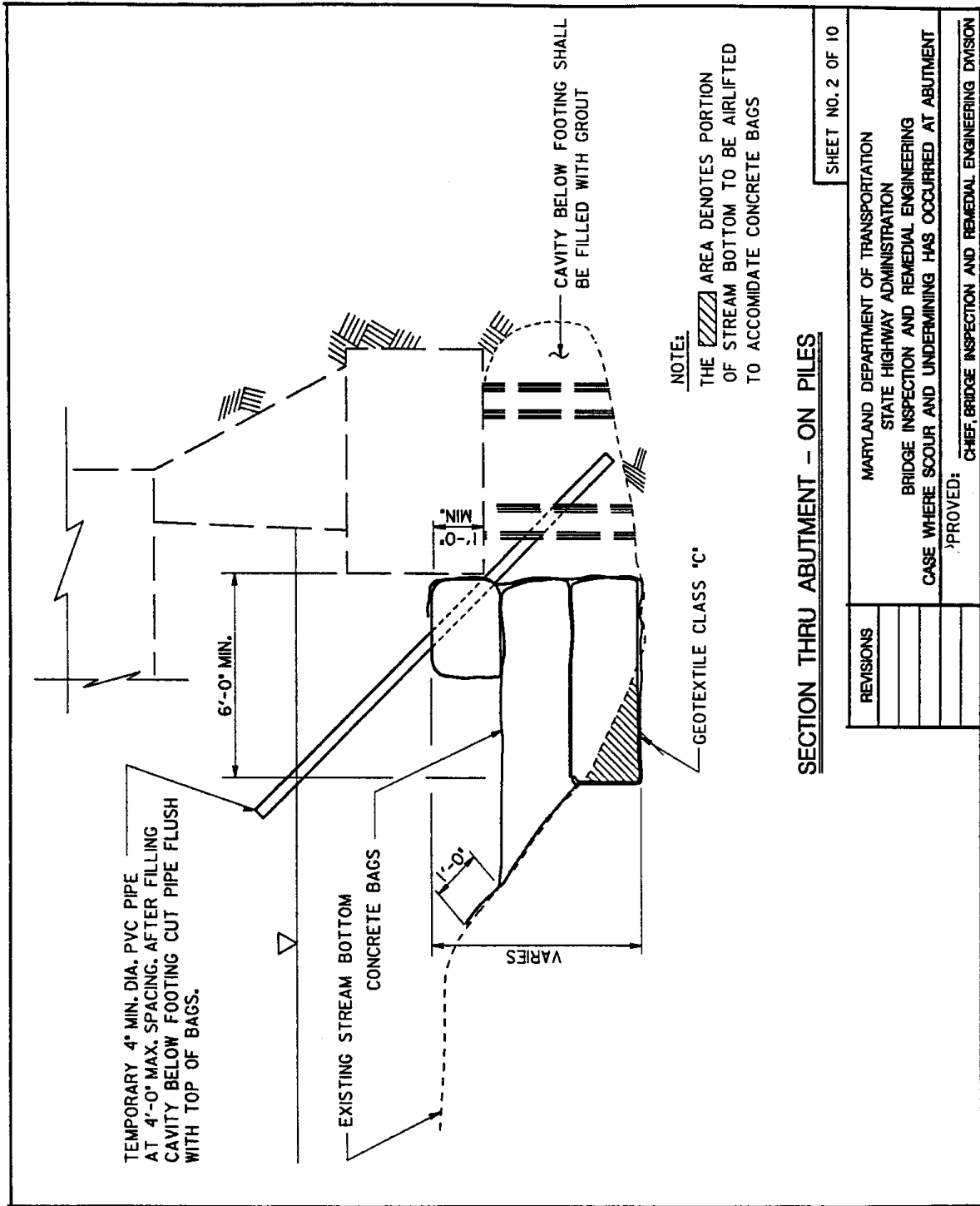

SECTION THRU ABUTMENT - ON PILES

SHEET NO. 2 OF 10

REVISIONS

MARYLAND DEPARTMENT OF TRANSPORTATION
 STATE HIGHWAY ADMINISTRATION
 BRIDGE INSPECTION AND REMEDIAL ENGINEERING
 CASE WHERE SCOUR AND UNDERMINING HAS OCCURRED AT ABUTMENT
 APPROVED: CHIEF, BRIDGE INSPECTION AND REMEDIAL ENGINEERING DIVISION

(page intentionally left blank)

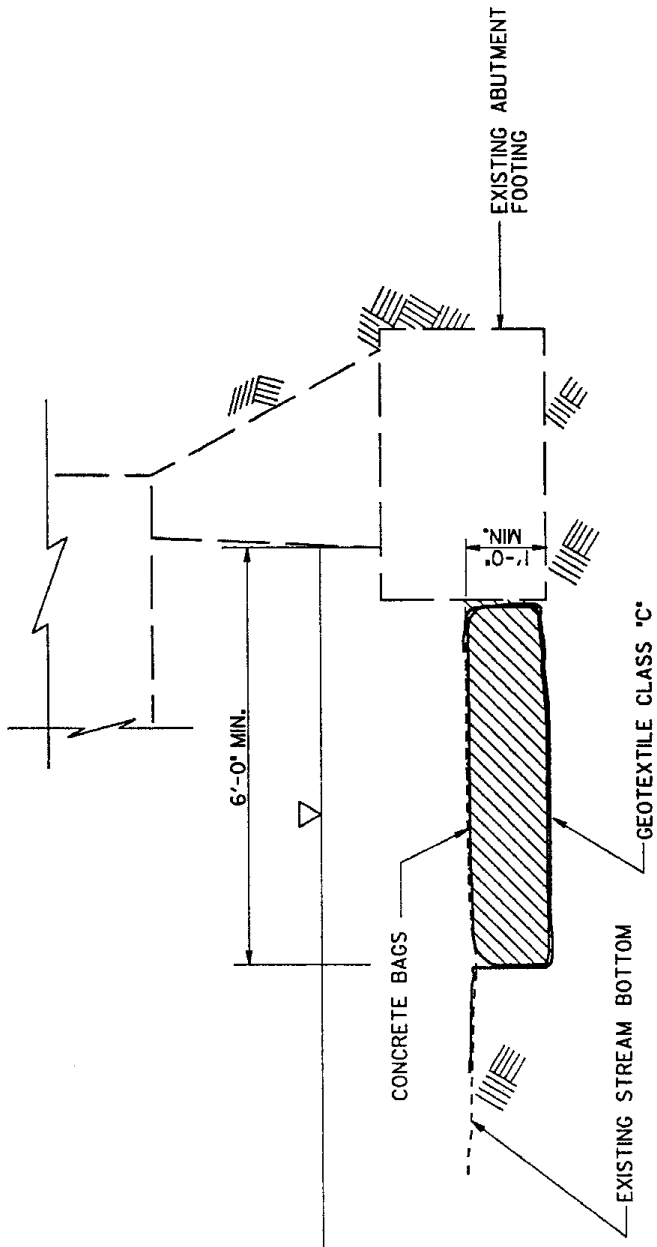

NOTE:
DO NOT EXCAVATE BELOW BOTTOM OF FOOTING
TO ACCOMMODATE CONCRETE BAGS.

SECTION THRU ABUTMENT - NO PILES

SHEET NO. 3 OF 10

REVISIONS	MARYLAND DEPARTMENT OF TRANSPORTATION STATE HIGHWAY ADMINISTRATION BRIDGE INSPECTION AND REMEDIAL ENGINEERING CASE WHERE SCOUR PROTECTION EXISTS AT ABUTMENT PROVIDED: CHIEF, BRIDGE INSPECTION AND REMEDIAL ENGINEERING DIVISION

NOTE:
THE [Hatched Area] AREA DENOTES PORTION
OF STREAM BOTTOM TO BE AIRLIFTED
TO ACCOMMODATE CONCRETE BAGS

(page intentionally left blank)

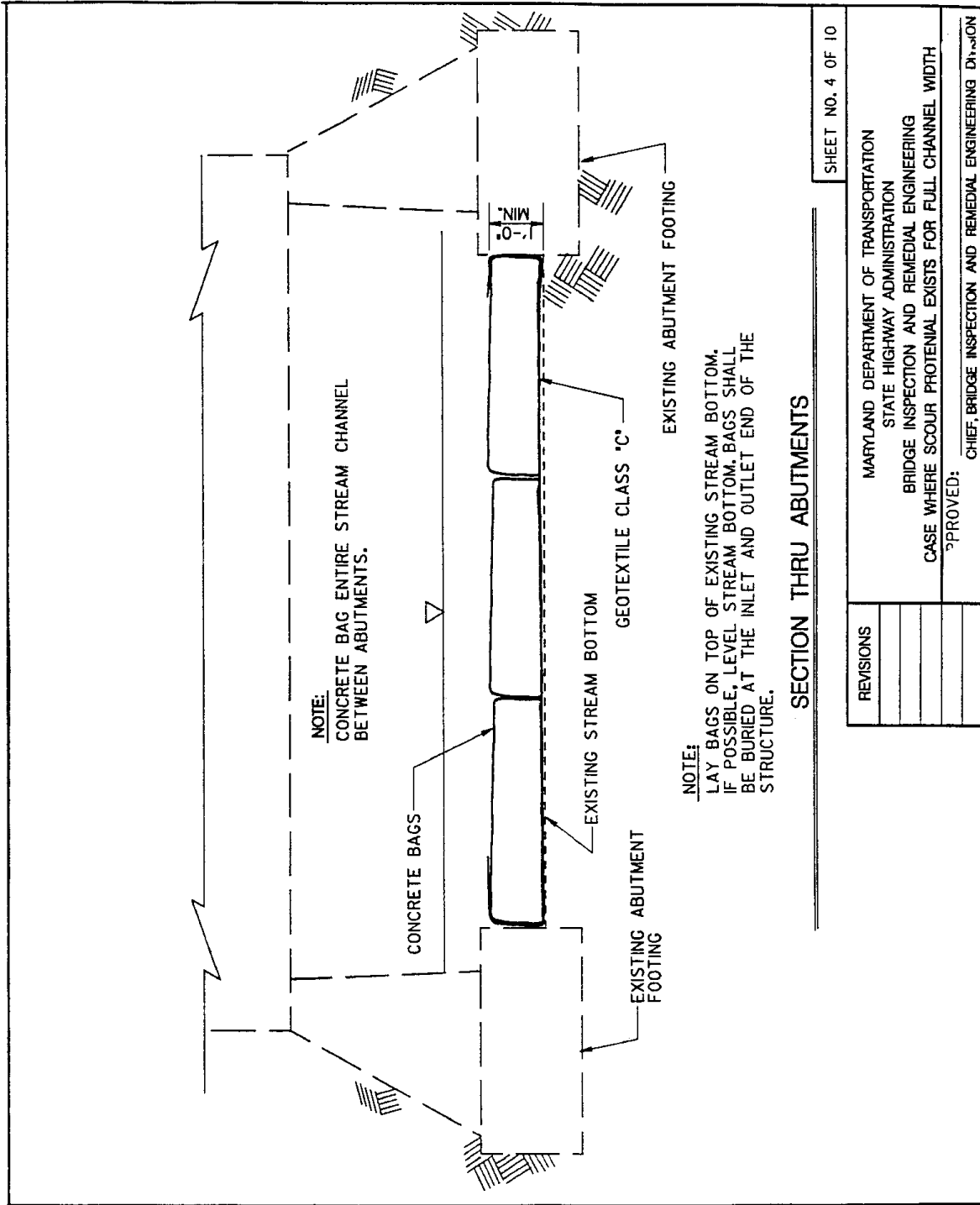

SHEET NO. 4 OF 10

REVISIONS	APPROVED:
	CHIEF, BRIDGE INSPECTION AND REMEDIAL ENGINEERING DIVISION
	BRIDGE INSPECTION AND REMEDIAL ENGINEERING
	STATE HIGHWAY ADMINISTRATION
	MARYLAND DEPARTMENT OF TRANSPORTATION

(page intentionally left blank)

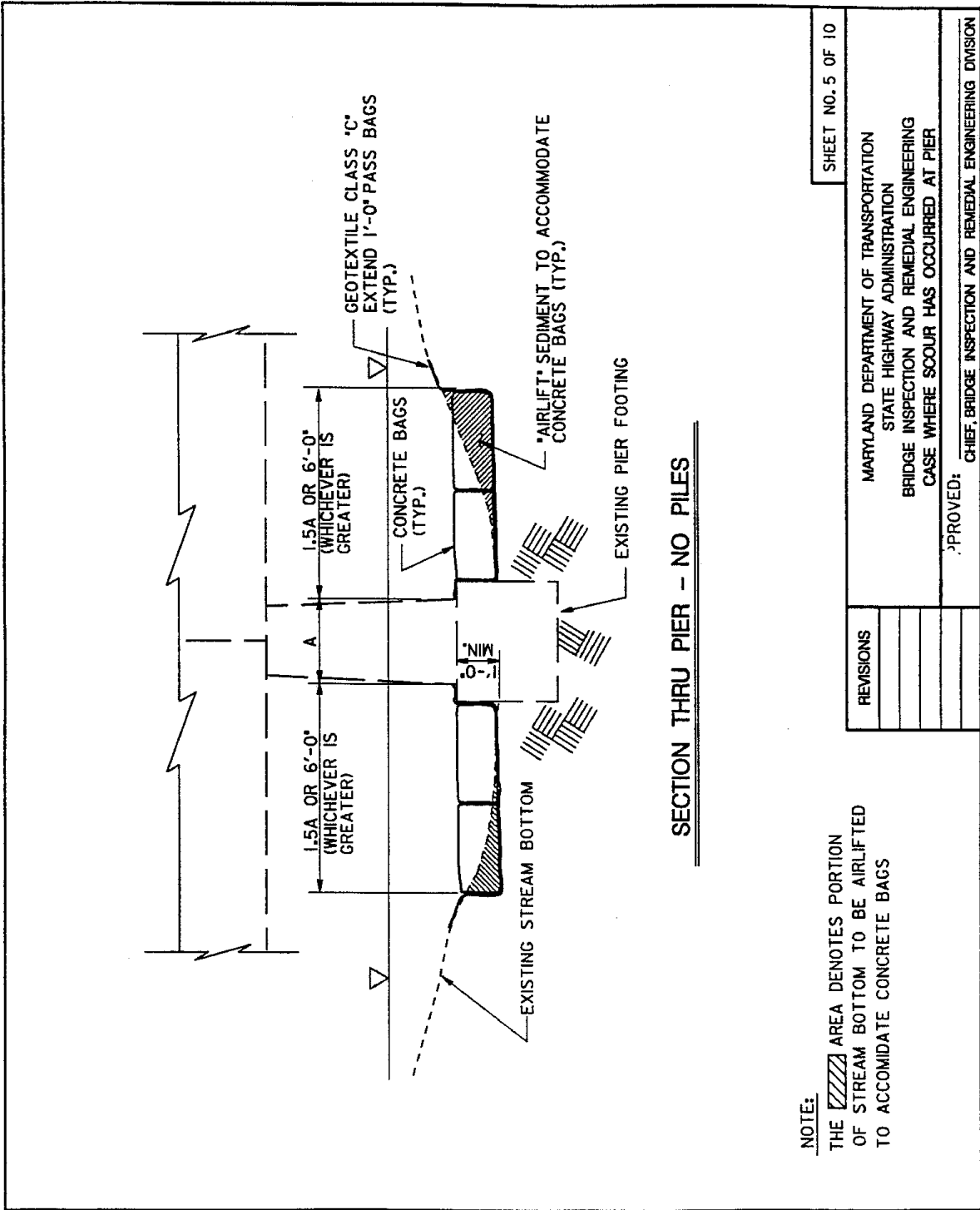

Sheet 5

DG7.19

(page intentionally left blank)

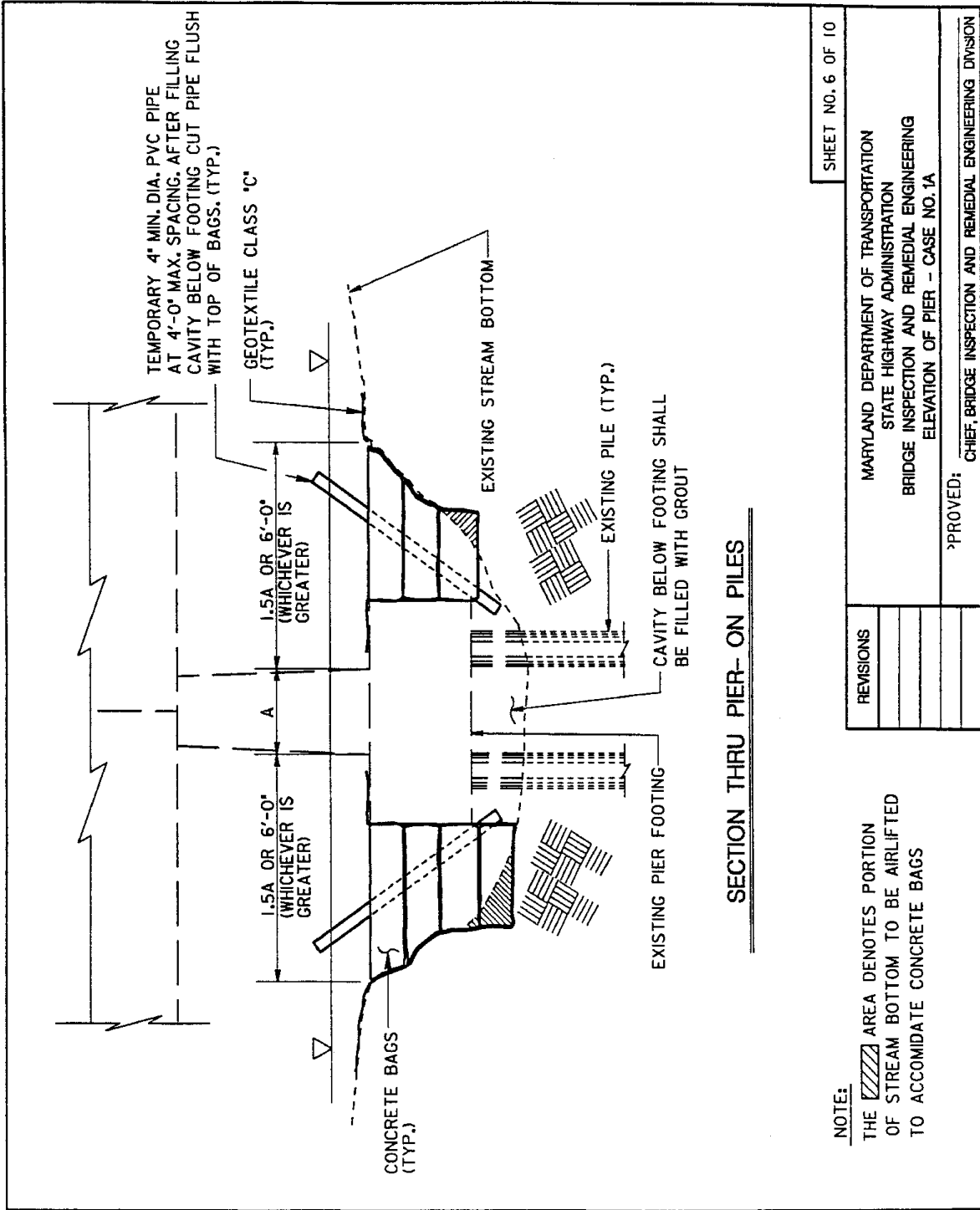

SECTION THRU PIER- ON PILES

NOTE:

THE [Hatched Area] AREA DENOTES PORTION OF STREAM BOTTOM TO BE AIRLIFTED TO ACCOMMODATE CONCRETE BAGS

REVISIONS

SHEET NO. 6 OF 10

MARYLAND DEPARTMENT OF TRANSPORTATION
STATE HIGHWAY ADMINISTRATION
BRIDGE INSPECTION AND REMEDIAL ENGINEERING
ELEVATION OF PIER - CASE NO. 1A

APPROVED: CHIEF, BRIDGE INSPECTION AND REMEDIAL ENGINEERING DIVISION

(page intentionally left blank)

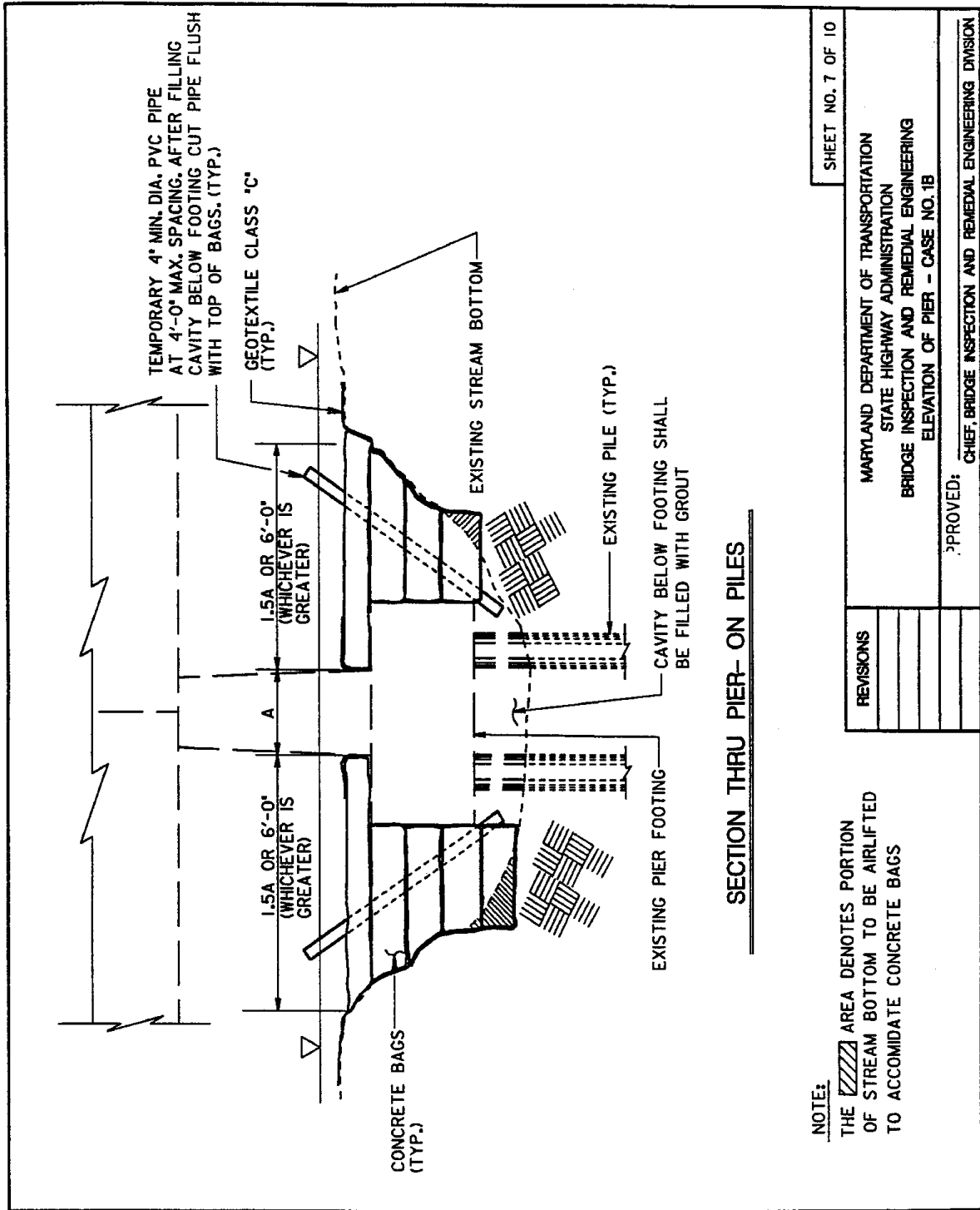

SHEET NO. 7 OF 10

MARYLAND DEPARTMENT OF TRANSPORTATION
STATE HIGHWAY ADMINISTRATION
BRIDGE INSPECTION AND REMEDIAL ENGINEERING
ELEVATION OF PIER - CASE NO. 1B

REVISIONS

APPROVED: _____
CHIEF, BRIDGE INSPECTION AND REMEDIAL ENGINEERING DIVISION

(page intentionally left blank)

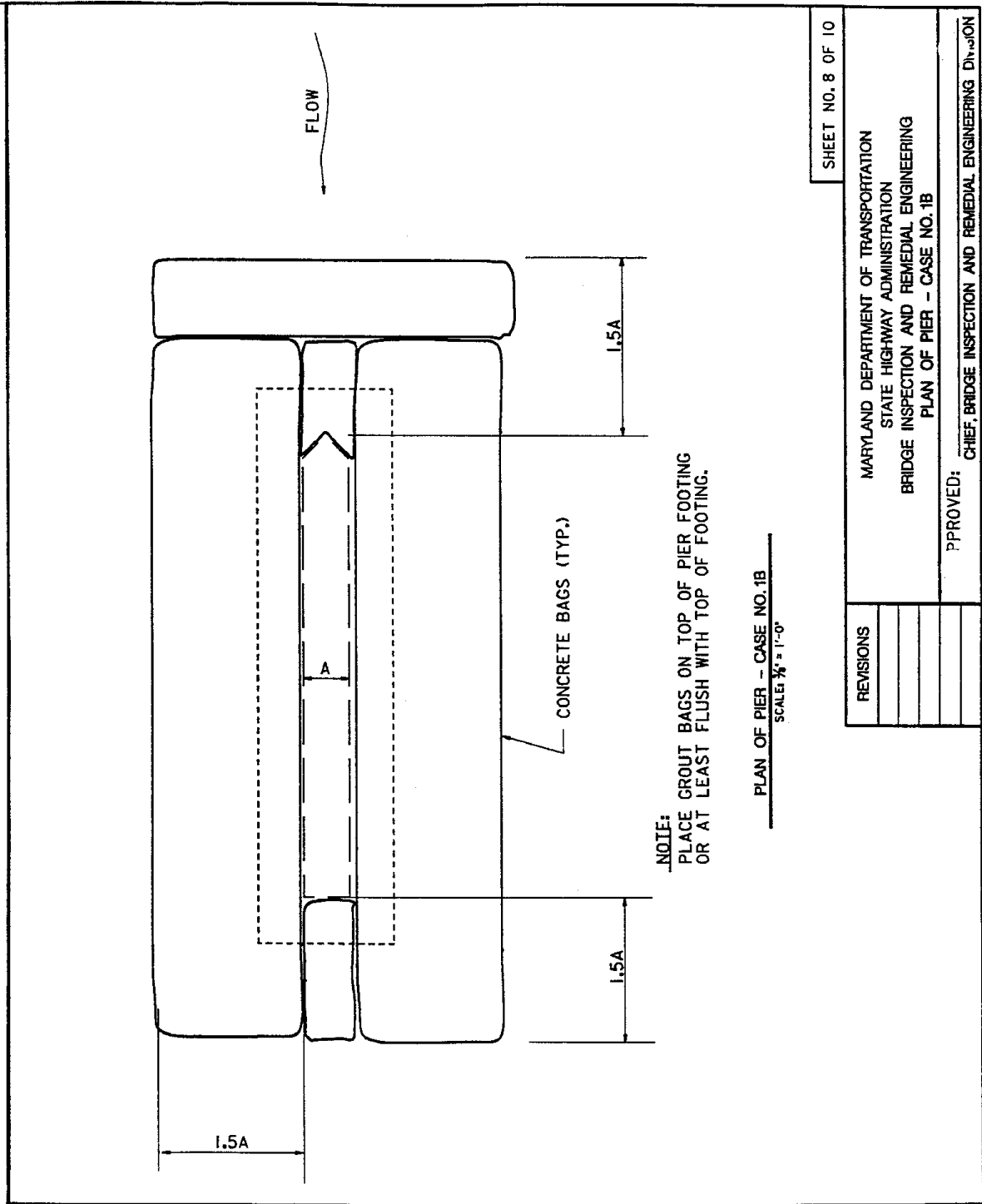

Sheet 8

DG7.25

(page intentionally left blank)

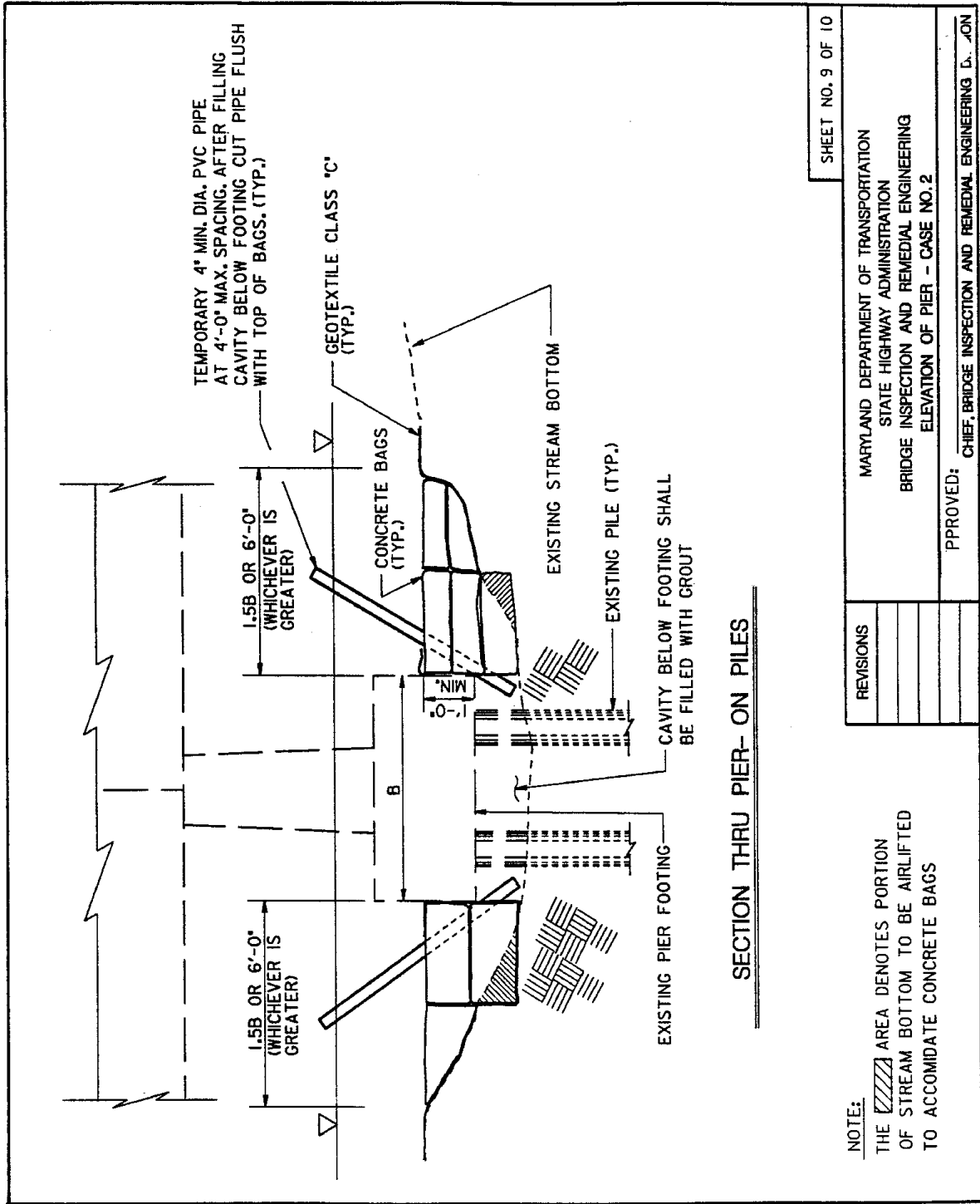

SHEET NO. 9 OF 10

REVISIONS	MARYLAND DEPARTMENT OF TRANSPORTATION STATE HIGHWAY ADMINISTRATION BRIDGE INSPECTION AND REMEDIAL ENGINEERING ELEVATION OF PIER - CASE NO. 2

APPROVED:
CHIEF, BRIDGE INSPECTION AND REMEDIAL ENGINEERING DIVISION

(page intentionally left blank)

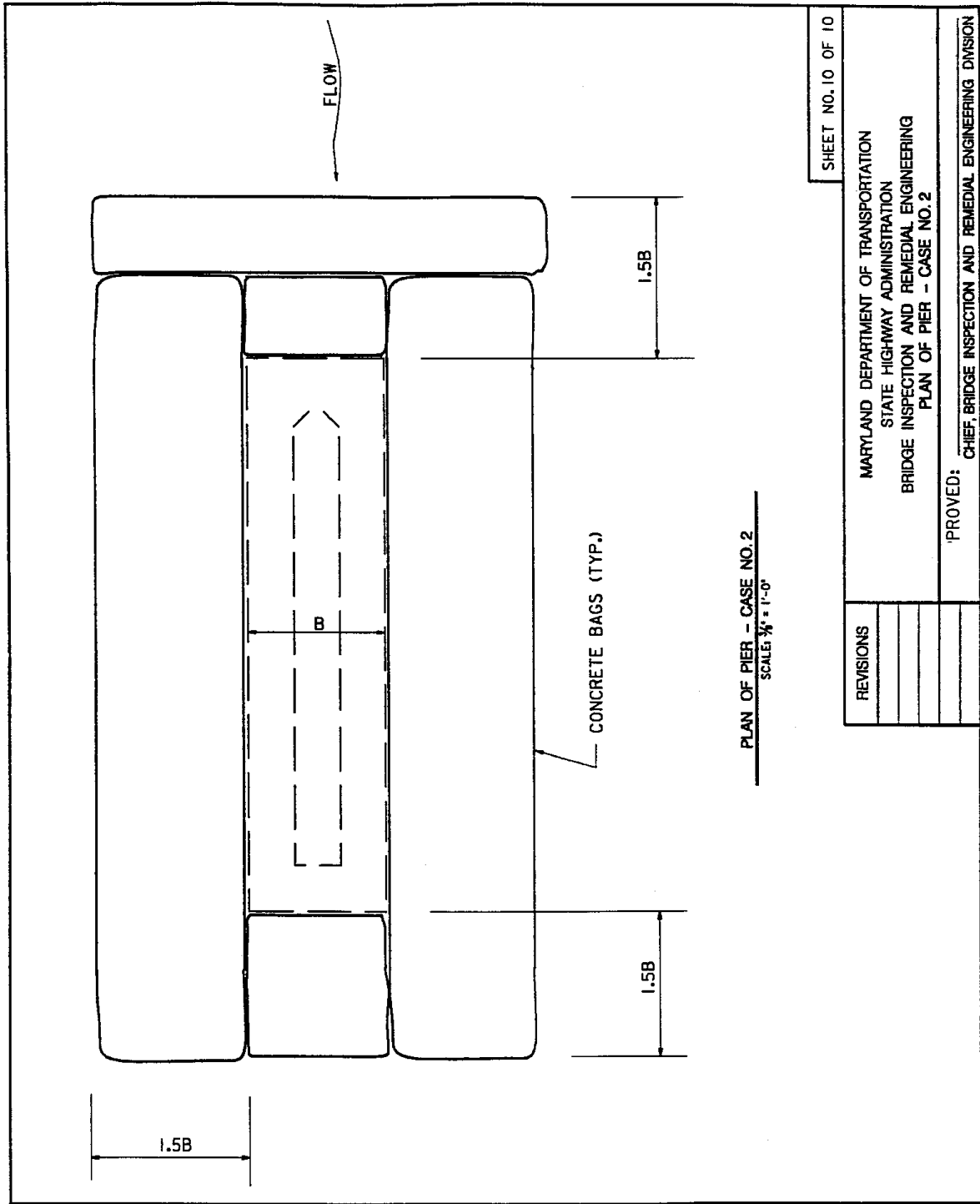

Sheet 10

DG7.29

(page intentionally left blank)

DESIGN GUIDELINE 8

ROCK RIPRAP AT PIERS AND ABUTMENTS

(page intentionally left blank)

DESIGN GUIDELINE 8

ROCK RIPRAP AT PIERS AND ABUTMENTS

8.1 INTRODUCTION

The FHWA continues to evaluate how best to design rock riprap at bridge piers and abutments. Present knowledge is based on research conducted under laboratory conditions with little field verification, particularly for piers. Flow turbulence and velocities around a pier are of sufficient magnitude that large rocks move over time. Bridges have been lost (Schoharie Creek bridge - see case study in Section 8.2) due to the removal of riprap at piers resulting from turbulence and high velocity flow. Usually this does not happen during one storm, but is the result of the cumulative effect of a sequence of high flows. **Therefore, if rock riprap is placed as scour protection around a pier, the bridge should be monitored and inspected during and after each high flow event to insure that the riprap is stable.**

8.2 CASE STUDY - SCHOHARIE CREEK BRIDGE FAILURE

The failure of the I-90 bridge over Schoharie Creek near Albany, New York on April 5, 1987, which cost 10 lives, was investigated by the National Transportation Safety Board (NTSB).⁽¹⁾ The peak flow was 1,838 m³/s (64,900 cfs) with a 70- to 100-year return period.

The foundations of the four bridge piers were large spread footings 25 m (82 ft) long, 5.5 m (18 ft) wide, and 1.5 m (5 ft) deep without piles. The footings were set 1.5 m (5 ft) into the stream bed in very dense ice contact stratified glacial drift, which was considered nonerodible by the designers (Figure 8.1). However, flume studies of samples of the stratified drift showed that some material would be eroded at a velocity of 1.5 m/s (4 ft/s), and at a velocity of 2.4 m/s (8 ft/s) the erosion rates were high.⁽²⁾

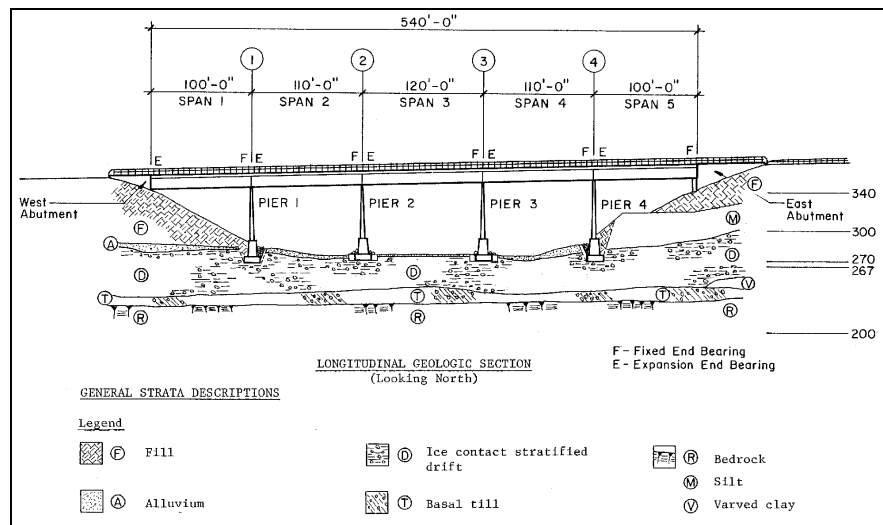

Figure 8.1. South elevation - Schoharie Creek Bridge showing key structural features and a schematic geological section.⁽²⁾

A 1 to 50 scale, 3-dimensional, model study established a flow velocity of 3.3 m/s (10.8 ft/s) at the pier that failed. Also, the 1 to 50 scale and a 1 to 15 scale, 2-dimensional model study gave 4.6 m (15 ft) of maximum scour depth. The scour depth of the prototype pier (pier 3) at failure was 4.3 m (14 ft)⁽²⁾ (see Figure 8.2).

Design plans called for the footings to be protected with riprap. Over time (1953 to 1987) much of the riprap was removed by high flows. NTSB gave as the probable cause "....the failure of the New York State Thruway authority to maintain adequate riprap around the bridge piers, which led to severe erosion in the soil beneath the spread footings. Contributing to the severity of the accident was the lack of structural redundancy in the bridge."⁽¹⁾ For additional information on this bridge failure see HEC-18, Chapter 11.⁽³⁾



Figure 8.2. Pier scour holes at Schoharie Creek bridge in 1987. Pier 2 in the foreground with pier 3 in the background.⁽²⁾

8.3 SIZING ROCK RIPRAP AT PIERS

As a countermeasure for scour at piers for existing bridges, riprap can reduce the risk of failure and in some cases could make a bridge safe from scour (see HEC-18, Appendix J for additional guidance.⁽³⁾ Riprap is not recommended as a pier scour countermeasure for new bridges. Determine the D_{50} size of the riprap using the rearranged Isbash equation^(4,5) to solve for stone diameter (in meters (ft), for fresh water):

$$D_{50} = \frac{0.692 (KV)^2}{(S_s - 1)2g} \quad (8.1)$$

where:

- D_{50} = median stone diameter, m (ft)
- K = coefficient for pier shape
- V = velocity on pier, m/s (ft/s)
- S_s = specific gravity of riprap (normally 2.65)
- g = 9.81 m/s² (32.2 ft/s²)
- K = 1.5 for round-nose pier
- K = 1.7 for rectangular pier

The effect of turbulence intensity on required rock size is illustrated in Figure 8.3.

To determine V multiply the average channel velocity (Q/A) by a coefficient that ranges from 0.9 for a pier near the bank in a straight uniform reach of the stream to 1.7 for a pier in the main current of flow around a sharp bend.

1. Provide a riprap mat width which extends horizontally at least two times the pier width, measured from the pier face.
2. Place the top of a riprap mat at the same elevation as the streambed. Placing the bottom of a riprap mat on top of the streambed is discouraged. In all cases where riprap is used for scour control, the bridge must be monitored during and inspected after high flows.

It is important to note that it is a disadvantage to bury riprap so that the top of the mat is below the streambed because inspectors have difficulty determining if some or all of the riprap has been removed. Therefore, it is recommended to place the top of a riprap mat at the same elevation as the streambed.

- a. The thickness of the riprap mat should be three stone diameters (D_{50}) or more. In general, the bottom of the riprap blanket should be placed at or below the computed contraction scour depth.
- b. In some conditions, place the riprap on a geotextile or a gravel filter. However, if a well-graded riprap is used, a filter may not be needed. In some flow conditions it may not be possible to place a filter or if the riprap is buried in the bed a filter may not be needed.
- c. The maximum size rock should be no greater than twice the D_{50} size.

8.4 LABORATORY TESTING OF PIER RIPRAP

National Cooperative Highway Research Program (NCHRP) Project 24-7, "Countermeasures to Protect Bridge Piers from Scour," was completed in December 1998.^(6,7) This project evaluated alternatives to standard riprap installations as pier scour countermeasures, as well as various riprap configurations, including:

- Riprap with prior excavation and with geotextile or granular filter
- Riprap without prior excavation but with geotextile or granular filter
- Riprap without prior excavation, without geotextile or granular filter

Based on laboratory testing, this study concluded that under flood conditions in sand bed streams, riprap placed in the absence of a geotextile or granular filter layer would gradually settle and lose effectiveness over time, even under conditions for which the riprap is never directly mobilized by the flow. This settling is due to deformation and leaching of sand associated with the passage of bedforms. Riprap performance can be considerably improved with the use of a geotextile, especially if the geotextile is sealed to the pier.⁽⁷⁾ Design suggestions are provided in a User's Guide for various riprap configurations.⁽⁶⁾

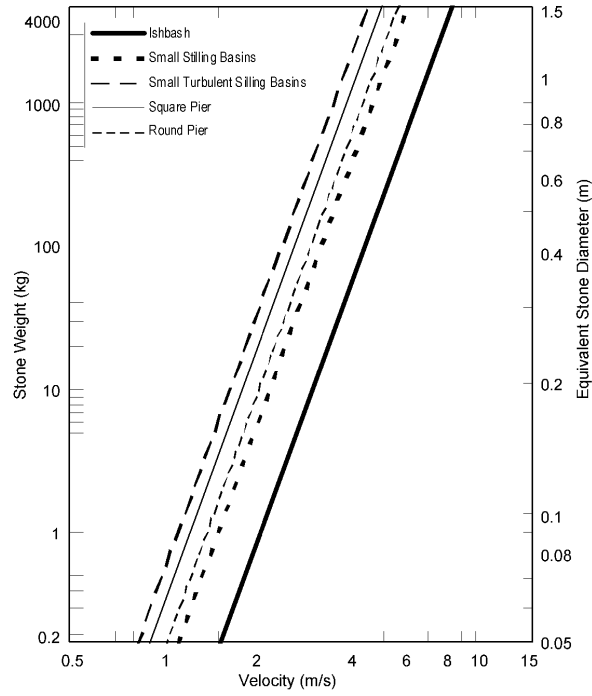

(SI Units)

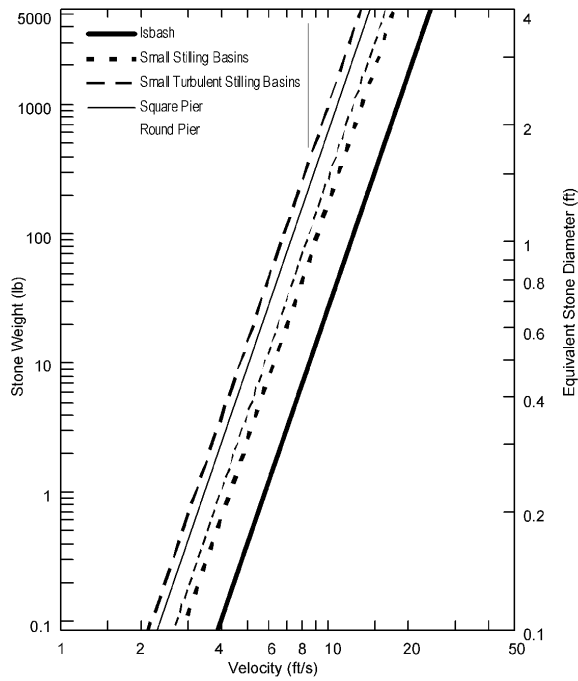

(English Units)

Figure 8.3. Effect of turbulence intensity on rock size using the Isibash approach.

8.5 DESIGN EXAMPLE FOR RIPRAP AT EXISTING BRIDGE PIERS (SI)

Riprap is to be sized for an existing 1.8 m diameter circular pier. The velocity was determined to be 1.8 m/s using the continuity equation. The pier is located between the bank and the thalweg on a gradual bend. A velocity multiplier of 1.2 should be used to account for pier location in the channel, since the calculated value represents a cross section average. The computed contraction scour at the pier is approximately 1.2 m.

Step 1. Determine D_{50} and D_{max} for the riprap protection using Equation 8.1.

$$D_{50} = \frac{0.692 (KV)^2}{(S_s - 1)2g}$$

$$D_{50} = 0.692 \frac{[(1.5)(1.2)(1.8)]^2}{(2.65 - 1)(2)(9.81)} = 0.22 \text{ m}$$

$$D_{max} = 2(0.22) = 0.44 \text{ m}$$

Step 2. Extent of riprap from edge of pier = $2(1.8) = 3.6 \text{ m}$.

Step 3. Depth of riprap from streambed at pier = Contraction Scour = 1.2 m.

Step 4. Use well graded riprap such that placement of filter material under water can be avoided. The gradation should be determined using Design Guideline 12. This part of the design is not conducted here.

Figure 8.4 presents the riprap placement resulting from the design.

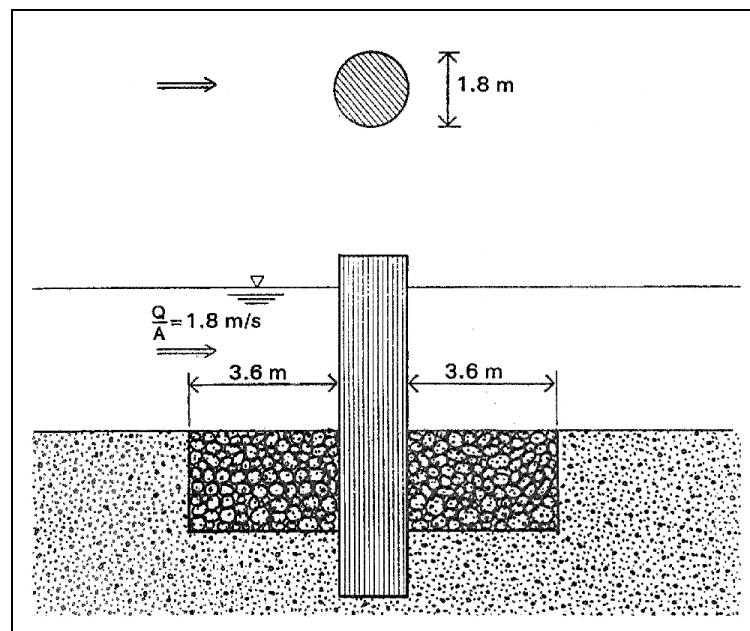

Figure 8.4. Placement of pier riprap (SI).

8.6 DESIGN EXAMPLE FOR RIPRAP AT EXISTING BRIDGE PIERS (English)

Riprap is to be sized for an existing 6 ft diameter circular pier. The velocity was determined to be 1.8 m/s using the continuity equation. The pier is located between the bank and the thalweg on a gradual bend. A velocity multiplier of 1.2 should be used to account for pier location in the channel, since the calculated value represents a cross section average. The computed contraction scour at the pier is approximately 3.9 ft.

Step 1. Determine D_{50} and D_{max} for the riprap protection using Equation 8.1.

$$D_{50} = \frac{0.692 (KV)^2}{(S_s - 1)2g}$$

$$D_{50} = 0.692 \frac{[(1.5)(1.2)(6)]^2}{(2.65 - 1)(2)(32.2)} = 0.8 \text{ ft}$$

$$D_{max} = 2(0.8) = 1.6 \text{ ft}$$

Step 2. Extent of riprap from edge of pier = $2(6) = 12 \text{ ft}$.

Step 3. Depth of riprap from streambed at pier = Contraction Scour = 3.9 ft.

Step 4. Use well graded riprap such that placement of filter material under water can be avoided. The gradation should be determined using Design Guideline 12. This part of the design is not conducted here.

Figure 8.5 presents the riprap placement resulting from the design.

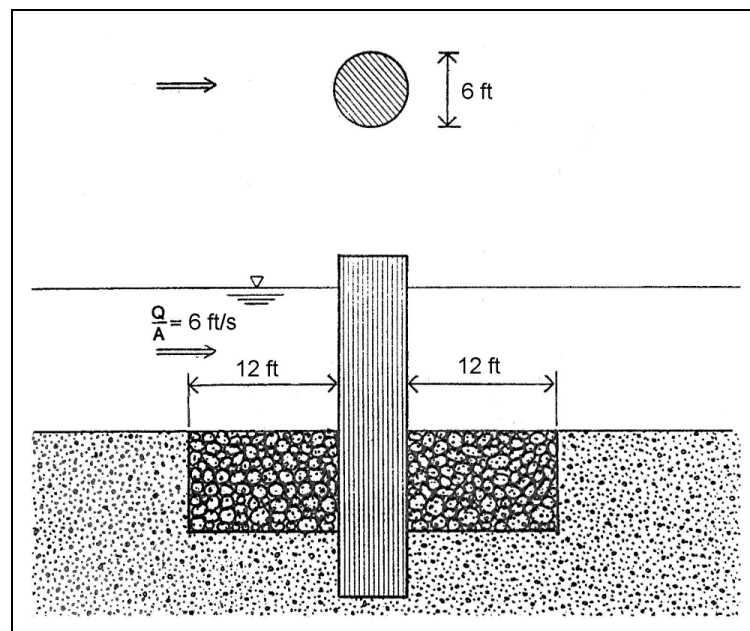

Figure 8.5. Placement of pier riprap (English).

8.7 SIZING ROCK RIPRAP AT ABUTMENTS

The FHWA conducted two research studies in a hydraulic flume to determine equations for sizing rock riprap for protecting abutments from scour.^(8,9) The first study investigated vertical wall and spill-through abutments which encroached 28 and 56 percent on the floodplain, respectively. The second study investigated spill-through abutments which encroached on a floodplain with an adjacent main channel (Figure 8.6). Encroachment varied from the largest encroachment used in the first study to a full encroachment to the edge of main channel bank. For spill-through abutments in both studies, the rock riprap consistently failed at the toe downstream of the abutment centerline (Figure 8.7). For vertical wall abutments, the first study consistently indicated failure of the rock riprap at the toe upstream of the centerline of the abutment.

Field observations and laboratory studies reported in HDS 6⁽⁴⁾ indicate that with large overbank flow or large drawdown through a bridge opening that scour holes develop on the side slopes of spill-through abutments and the scour can be at the upstream corner of the abutment. In addition, flow separation can occur at the downstream side of a bridge (either with vertical wall or spill-through abutments). This flow separation causes vertical vortices which erode the approach embankment and the downstream corner of the abutment.

For Froude Numbers $(V/(gy)^{1/2}) \leq 0.80$, the recommended design equation for sizing rock riprap for spill-through and vertical wall abutments is in the form of the Isbash relationship:

$$\frac{D_{50}}{y} = \frac{K}{(S_s - 1)} \left[\frac{V^2}{gy} \right] \quad (8.2)$$

where:

- D_{50} = median stone diameter, m (ft)
- V = characteristic average velocity in the contracted section (explained below), m/s (ft/s)
- S_s = specific gravity of rock riprap
- g = gravitational acceleration, 9.81 m/s² (32.2 ft/s²)
- y = depth of flow in the contracted bridge opening, m (ft)
- K = 0.89 for a spill-through abutment
1.02 for a vertical wall abutment

For Froude Numbers >0.80 , Equation 8.3 is recommended:⁽¹⁰⁾

$$\frac{D_{50}}{y} = \frac{K}{(S_s - 1)} \left[\frac{V^2}{gy} \right]^{0.14} \quad (8.3)$$

where:

- K = 0.61 for spill-through abutments
= 0.69 for vertical wall abutments

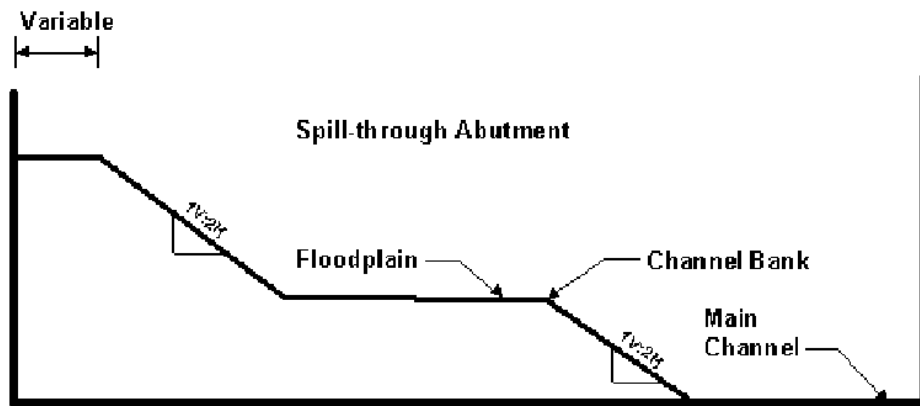

Figure 8.6. Section view of a typical setup of spill-through abutment on a floodplain with adjacent main channel.

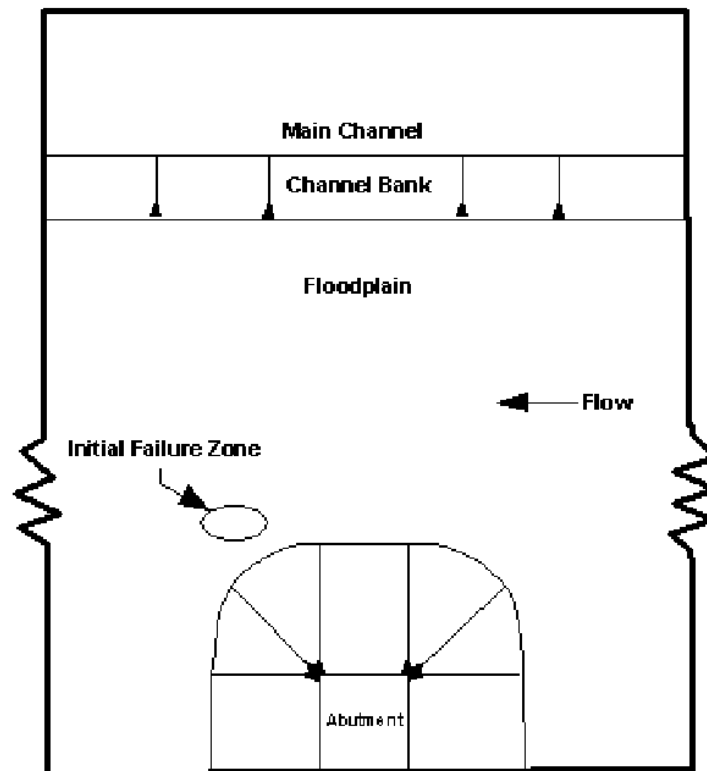

Figure 8.7. Plan view of the location of initial failure zone of rock riprap for spill-through abutment.

In both equations, the coefficient K, is a velocity multiplier to account for the apparent local acceleration of flow at the point of rock riprap failure. Both of these equations are envelope relationships that were forced to over predict 90 percent of the laboratory data.

A recommended procedure for selecting the characteristic average velocity is as follows:

1. Determine the set-back ratio (SBR) of each abutment. SBR is the ratio of the set-back length to channel flow depth. The set-back length is the distance from the near edge of the main channel to the toe of abutment.

$$\text{SBR} = \text{Set-back length} / \text{average channel flow depth}$$

- a. If SBR is less than 5 for both abutments (Figure 8.8), compute a characteristic average velocity, Q/A , based on the entire contracted area through the bridge opening. This includes the total upstream flow, exclusive of that which overtops the roadway. The WSPRO average velocity through the bridge opening is also appropriate for this step.
 - b. If SBR is greater than 5 for an abutment (Figure 8.9), compute a characteristic average velocity, Q/A , for the respective overbank flow only. Assume that the entire respective overbank flow stays in the overbank section through the bridge opening. This velocity can be approximated by a hand calculation using the cumulative flow areas in the overbank section from WSPRO, or from a special WSPRO run using an imaginary wall along the bank line.
 - c. If SBR for an abutment is less than 5 and SBR for the other abutment at the same site is more than 5 (Figure 8.10), a characteristic average velocity determined from Step 1a for the abutment with SBR less than 5 may be unrealistically low. This would, of course, depend upon the opposite overbank discharge as well as how far the other abutment is set back. For this case, the characteristic average velocity for the abutment with SBR less than 5 should be based on the flow area limited by the boundary of that abutment and an imaginary wall located on the opposite channel bank. The appropriate discharge is bounded by this imaginary wall and the outer edge of the floodplain associated with that abutment.
2. Compute rock riprap size from Equations 8.2 or 8.3, based on the Froude Number limitation for these equations.
 3. Determine extent of rock riprap.
 - a. The apron at the toe of the abutment should extend along the entire length of the abutment toe, around the curved portions of the abutment to the point of tangency with the plane of the embankment slopes.
 - b. The apron should extend from the toe of the abutment into the bridge waterway a distance equal to twice the flow depth in the overbank area near the embankment, but need not exceed 7.5 m (25 ft) (Figure 8.11).⁽¹¹⁾
 - c. Spill-through abutment slopes should be protected with the rock riprap size computed from Equations 8.2 or 8.3 to an elevation 0.6 m (2 ft) above expected high water elevation for the design flood. Upstream and downstream coverage should agree with step 3a except that the downstream riprap should extend back from the abutment 2 flow depths or 7.5 m (25 ft) which ever is larger to protect the approach embankment. Several States in the southeast use a guide bank 15 m (50 ft) long at the downstream end of the abutment to protect the downstream side of the abutment.

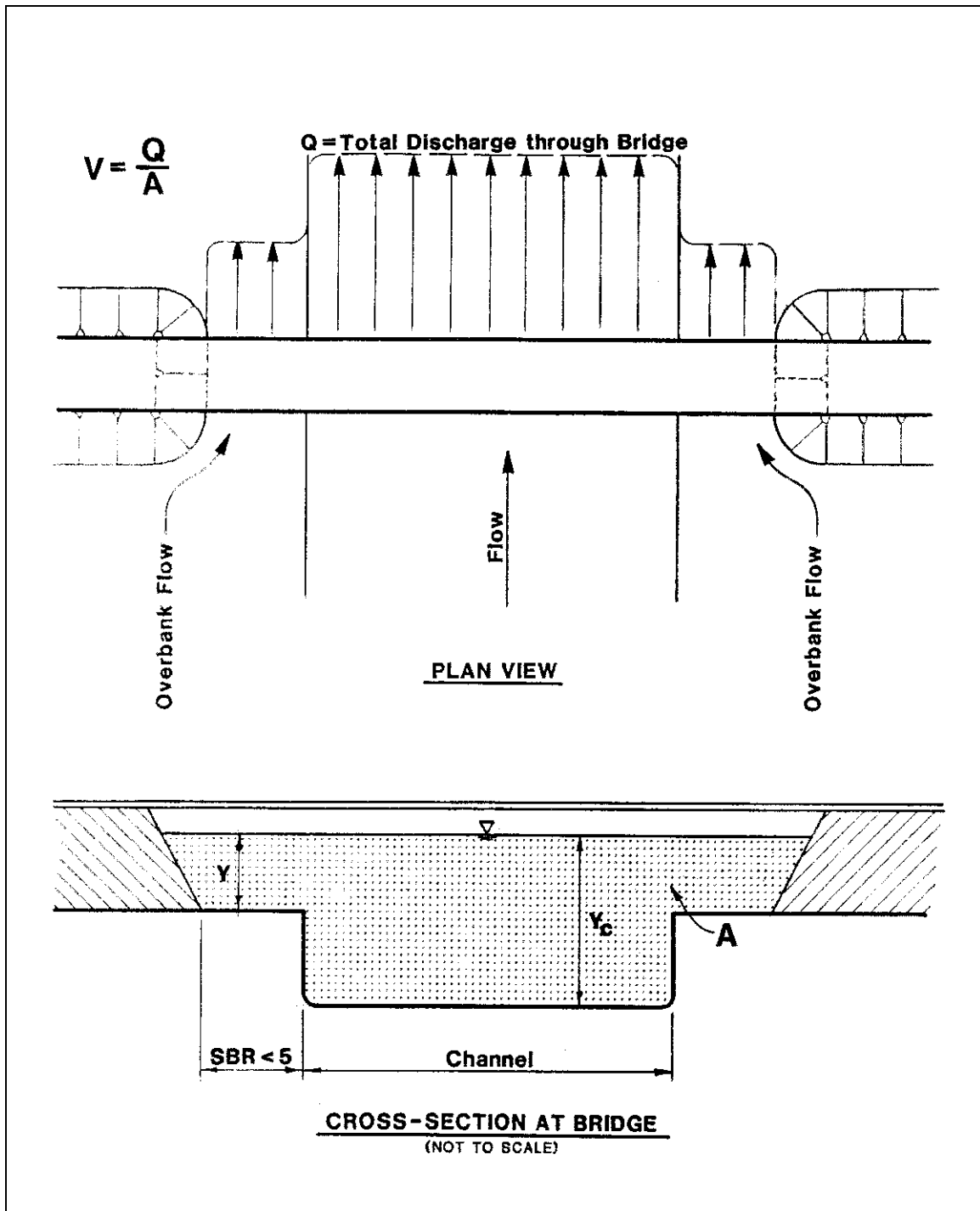

Figure 8.8. Characteristic average velocity for SBR<5.

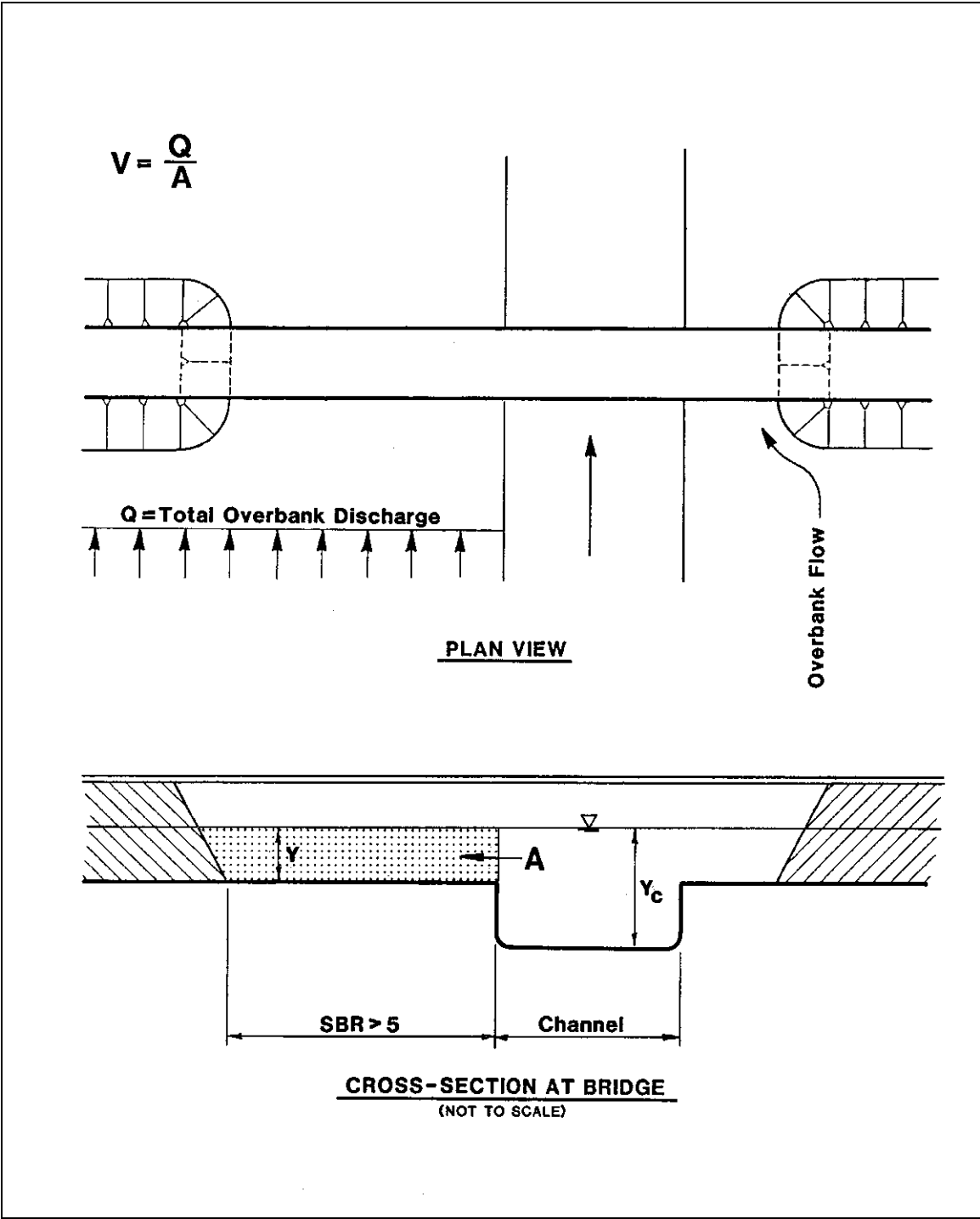

Figure 8.9. Characteristic average velocity for SBR>5.

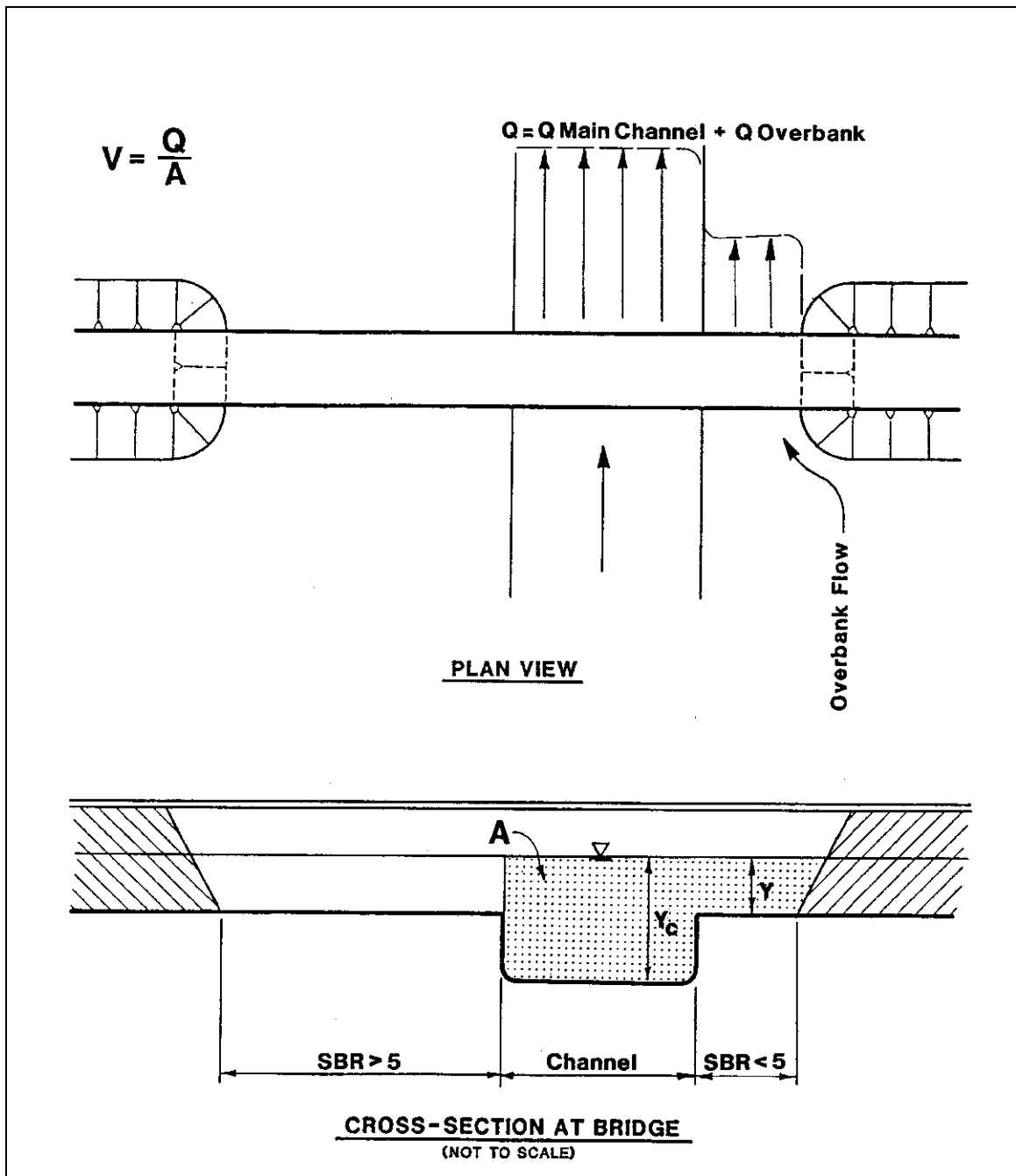

Figure 8.10. Characteristic average velocity for $SBR > 5$ and $SBR < 5$.

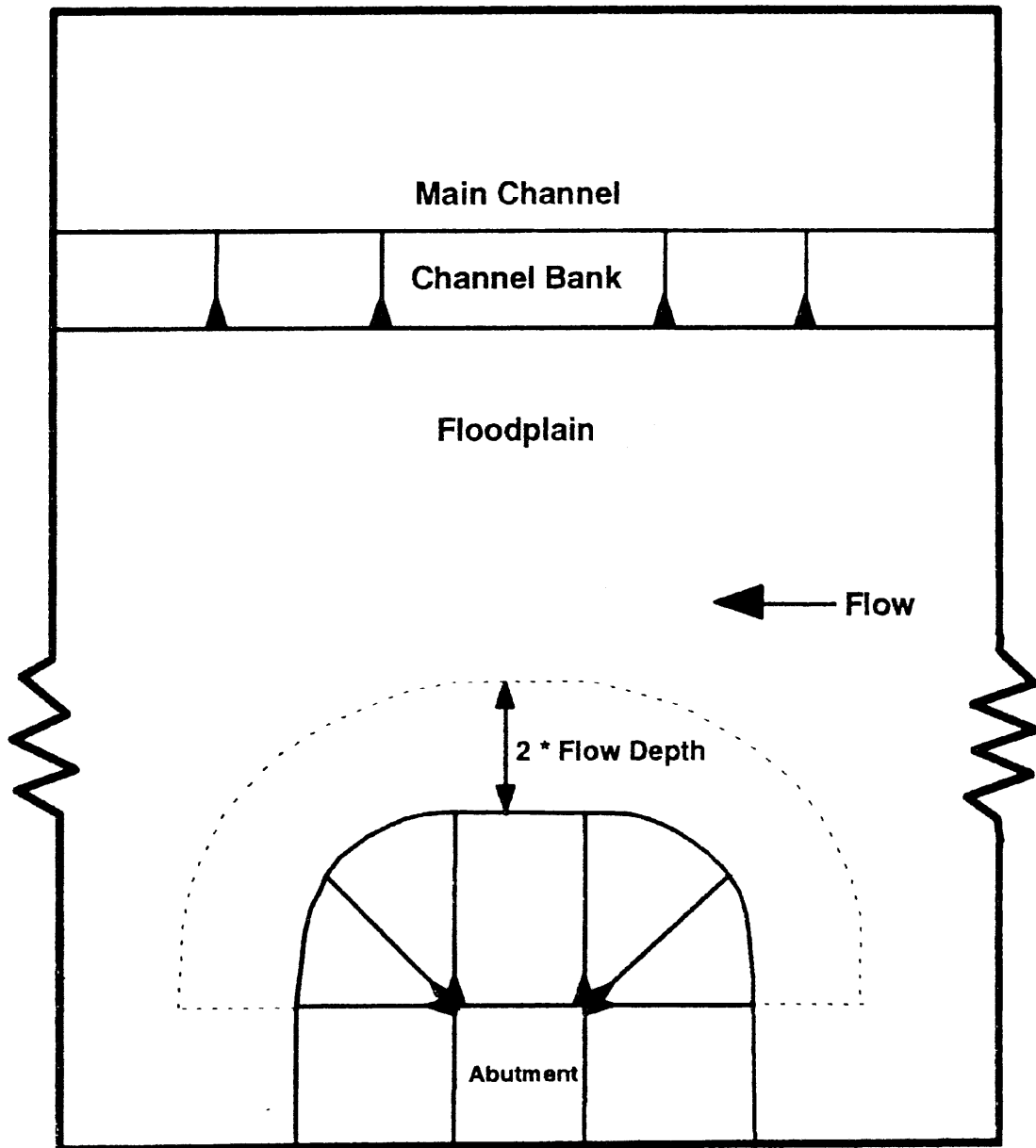

Figure 8.11. Plan view of the extension of rock riprap apron.

- d. The rock riprap thickness should not be less than the larger of either 1.5 times D_{50} or D_{100} . The rock riprap thickness should be increased by 50 percent when it is placed under water to provide for the uncertainties associated with this type of placement.
- e. The rock riprap gradation and potential need for underlying filter material must be considered (see Design Guideline 12).

8.8 DESIGN EXAMPLE FOR RIPRAP AT BRIDGE ABUTMENTS (SI)

Riprap is to be sized for an abutment located on the floodplain at an existing bridge. The bridge is 198.12 m long, has spill through abutments on a 1V:2H side slope and 7 equally spaced spans. The left abutment is set back from the main channel 68.8 m. Given the following table of hydraulic characteristics for the left abutment size the riprap.

Hydraulic Property	Value	Remarks
y (m)	0.83	Flow depth adjacent to abutment
Q (m ³ /s)	218.6	Discharge in left overbank
A (m ²)	57	Flow area of left overbank

Step 1. Determine characteristic average velocity, V. Abutment is set back more than 5 average flow depths, therefore overbank discharge and areas are used to determine V.

$$V = Q/A = 218.6/57 = 3.84 \text{ m/s}$$

Step 2. Determine the Froude Number of the flow.

$$Fr = V/(gy)^{1/2} = 3.84/(9.81(0.83))^{1/2} = 1.35$$

Step 3. Determine the D_{50} of the riprap for the left abutment. The Froude Number is greater than 0.8, therefore, use Equation 8.3.

$$\frac{D_{50}}{y} = \frac{K}{(S_s - 1)} \left[\frac{V^2}{gy} \right]^{0.14}$$

$$\frac{D_{50}}{0.83} = \frac{0.61}{2.65 - 1} \left[\frac{(3.84)^2}{(9.81)(0.83)} \right]^{0.14} = 0.40$$

$$D_{50} = 0.4(0.83) = 0.33 \text{ m}$$

Step 4. Determine riprap extent and layout.

- Extent into floodplain from toe of slope = $2(0.83) = 1.66 \text{ m}$
- Vertical extent up abutment slope from floodplain = $0.6 \text{ m} + 0.83 \text{ m} = 1.4 \text{ m}$
- The downstream face of the embankment should be protected a distance of 7.5 m from the point of tangency between the curved portion of the abutment and the plane of the embankment slope.
- Riprap mattress thickness = $1.5(0.33) = 0.50 \text{ m}$. Also, the thickness should not be less than D_{100} .
- Riprap gradation and filter requirements should be designed using Design Guideline 12. This portion of the design is not conducted for this example.

8.9 DESIGN EXAMPLE FOR RIPRAP AT BRIDGE ABUTMENTS (English)

Riprap is to be sized for an abutment located on the floodplain at an existing bridge. The bridge is 650 ft long, has spill through abutments on a 1V:2H side slope and 7 equally spaced spans. The left abutment is set back from the main channel 225 ft. Given the following table of hydraulic characteristics for the left abutment size the riprap.

Hydraulic Property	Value	Remarks
y (ft)	2.7	Flow depth adjacent to abutment
Q (cfs)	7,720	Discharge in left overbank
A (ft ²)	613.5	Flow area of left overbank

Step 1. Determine characteristic average velocity, V. Abutment is set back more than 5 average flow depths, therefore overbank discharge and areas are used to determine V.

$$V = Q/A = 7720/613.5 = 12.6 \text{ ft/s}$$

Step 2. Determine the Froude Number of the flow.

$$Fr = V/(gy)^{1/2} = 12.6/(32.2(2.7))^{1/2} = 1.35$$

Step 3. Determine the D_{50} of the riprap for the left abutment. The Froude Number is greater than 0.8, therefore, use Equation 8.3.

$$\frac{D_{50}}{y} = \frac{K}{(S_s - 1)} \left[\frac{V^2}{gy} \right]^{0.14}$$

$$\frac{D_{50}}{2.7} = \frac{0.61}{2.65 - 1} \left[\frac{12.6^2}{(32.2)(2.7)} \right]^{0.14} = 0.40$$

$$D_{50} = 0.4(0.83) = 0.33$$

Step 4. Determine riprap extent and layout.

- Extent into floodplain from toe of slope = $2(2.7) = 5.4$ ft
- Vertical extent up abutment slope from floodplain = $2.0 \text{ ft} + 2.7 \text{ ft} = 4.7$ ft
- The downstream face of the embankment should be protected a distance of 25 ft from the point of tangency between the curved portion of the abutment and the plane of the embankment slope.
- Riprap mattress thickness = $1.5 (1.1) = 1.7$ ft. Also, the thickness should not be less than D_{100} .
- Riprap gradation and filter requirements should be designed using Design Guideline 12. This portion of the design is not conducted for this example.

8.10 REFERENCES

1. NTSB, 1988, "Collapse of the New York Thruway (I-90) Bridge over the Schoharie, Creek, Near Amsterdam, New York, April 5, 1987," NTSB/HAR-88/02, NTSB, Washington, D.C.
2. RCI (Ayres Associates) and Colorado State University, 1987, "Hydraulic, Erosion, and Channel Stability Analysis of the Schoharie Creek Bridge Failure, New York," for NTSB and NY Thruway Authority, Fort Collins, CO.
3. Richardson, E.V. and S.R. Davis, 2001, "Evaluating Scour at Bridges," Hydraulic Engineering Circular 18, Fourth Edition, FHWA NHI 01-001, Federal Highway Administration, U.S. Department of Transportation, Washington, D.C.
4. Richardson, E.V., D.B. Simons, and P.F. Lagasse, 2001, "River Engineering for Highway Encroachments - Highways in the River Environment," Report FHWA NHI 01-004, Federal Highway Administration, Hydraulic Design Series NO. 6, Washington, D.C.
5. Parola, A.C., Jr., 1991, "The Stability of Riprap Used to Protect Bridge Piers," FHWA-RD-91-063, U.S. Department of Transportation, Washington, D.C., July.
6. Parker, G., C. Toro-Escobar, and R.L. Voight, Jr., 1998, "Countermeasures to Protect Bridge Piers From Scour," User's Guide, Vol. 1, prepared for National Cooperative Highway Research Program, Transportation Research Board, National Research Council, NCHRP Project 24-7, St. Anthony Falls Laboratory, University of Minnesota, Minneapolis, MN (revised 7/1/99).
7. Parker, G., C. Toro-Escobar, and R.L. Voight, Jr., 1998, "Countermeasures to Protect Bridge Piers from Scour," Final Report, Vol. 2, prepared for National Cooperative Highway Research Program, Transportation Research Board, National Research Council, NCHRP Project 24-7, St. Anthony Falls Laboratory, University of Minnesota, Minneapolis, MN.
8. Pagán-Ortiz, Jorge E., 1991, "Stability of Rock Riprap for Protection at the Toe of Abutments Located at the Floodplain," FHWA Research Report No. FHWA-RD-91-057, U.S. Department of Transportation, Washington, D.C.
9. Atayee, A. Tamin, 1993, "Study of Riprap as Scour Protection for Spill-through Abutment," presented at the 72nd Annual TRB meeting in Washington, D.C., January.
10. Kilgore, Roger T., 1993, "HEC-18 Guidance for Abutment Riprap Design," unpublished internal correspondence to FHWA, January.
11. Atayee, A. Tamin, Jorge E. Pagán-Ortiz, J.S. Jones, and R.T. Kilgore, 1993, "A Study of Riprap as a Scour Protection for Spill-through Abutments," ASCE Hydraulic Conference, San Francisco, CA.

8.11 CONTACTS

Federal Highway Administration
Office of Bridge Technology
400 Seventh Street SW
Washington, D.C. 20590

Federal Highway Administration
RD&T, Turner Fairbank Highway Research Center
6300 Georgetown Pike
McLean, Virginia 22101-2296

DESIGN GUIDELINE 9

SPURS

(page intentionally left blank)

DESIGN GUIDELINE 9

SPURS

9.1 BACKGROUND

A spur can be a pervious or impervious structure projecting from the streambank into the channel. Spurs are used to deflect flowing water away from, or to reduce flow velocities in critical zones near the streambank, to prevent erosion of the bank, and to establish a more desirable channel alignment or width. The main function of spurs is to reduce flow velocities near the bank, which in turn, encourages sediment deposition due to these reduced velocities. Increased protection of banks can be achieved over time, as more sediment is deposited behind the spurs. Because of this, spurs may protect a streambank more effectively and at less cost than revetments. Furthermore, by moving the location of any scour away from the bank, partial failure of the spur can often be repaired before damage is done to structures along and across the stream.

Spurs are generally used to halt meander migration at a bend. They are also used to channelize wide, poorly defined streams into well-defined channels. The use of spurs to establish and maintain a well-defined channel location, cross section, and alignment in braided streams can decrease the required bridge lengths, thus decreasing the cost of bridge construction and maintenance.

Spur types are classified based upon their permeability as retarder spurs, retarder/deflector spurs, and deflector spurs. The permeability of spurs is defined simply as the percentage of the spur surface area facing the streamflow that is open. Deflector spurs are impermeable spurs which function by diverting the primary flow currents away from the bank. Retarder/deflector spurs are more permeable and function by retarding flow velocities at the bank and diverting flow away from the bank. Retarder spurs are highly permeable and function by retarding flow velocities near the bank.

Table 9.1 can be used as an aid in the selection of an appropriate spur type for a given situation.⁽¹⁾ The primary factors influencing the selection of a specific spur type are listed across the top, and primary spur types are evaluated in terms of those selection criteria. A scale from 1 to 5 is used to indicate the applicability of a specific spur for a given condition. A value of 1 indicates a disadvantage in using that spur type for given condition, and a value of 5 indicates a definite advantage. The table can be used by summing values horizontally for given site conditions to select the best spur type for the specific site. It should be recognized however, that adherence to the results of such a procedure assigns equal weight to each of the factors listed across the top of the table and places undue reliance on the accuracy and relative merit of values given in the rating table. It is recommended that values given in the table be used only for a qualitative evaluation of expected performance. Spur type selection should be based on the results of this evaluation as well as estimated costs, availability of materials, construction and maintenance requirements, and experience with the stream in which the spur installation is to be placed.

Table 9.1. Spur Type Performance (Brown). ⁽¹⁾																							
Spur Type	Function			Erosion Mechanism			Sediment Environment			Flow Environment			Bend Radius		Ice/Debris Environment								
	Project Ext. Bank	Re-est. Prev. Align.	Flow Construction	Transport	Shear Stress - Toe	Shear Stress - Upper Bank	Regime/Low Threshold	Medium Threshold	High	Velocity		Stage		Large	Medium	Small	Minimal	Light Debris	Large Debris/Ice				
										Low	Medium	High	Low							Medium	High		
Retarder																							
Fence Type	3	2	2	3	3*	1	1	4	3	2	3	3	2	3	2	1	3	2	1	3	3	2	
Jack/Tetrahedron	3	3	1	3	3	1	1	4	3	1	3	2	1	3	2	1	3	2	1	3	2	4	1
Retarder/Deflector																							
Light Fence	3	3	3	3	3	2	2	3	3	2	3	3	2	3	3	2	3	3	2	3	3	4	2
Heavy Diverter	3	4	4	3	3	4	3	2	3	3	3	2	2	3	3	4	3	3	2	3	3	2	3
Deflector																							
Hardpoint	3	4	4	3	3	3	4	2	3	4	3	3	4	3	3	2	3	4	4	3	3	3	5
Transverse Dike	3	4	4	3	3	3	4	2	3	4	3	3	4	3	3	2	3	4	3	3	3	3	5

*Henson spur jetties are rated a 4 for this condition.

1. Definite disadvantage to the use of this type structure.
2. Some disadvantage to the use of this type structure.
3. Adequate for condition.
4. Some advantage to the use of this type structure.
5. Significant advantage to the use of this type structure.

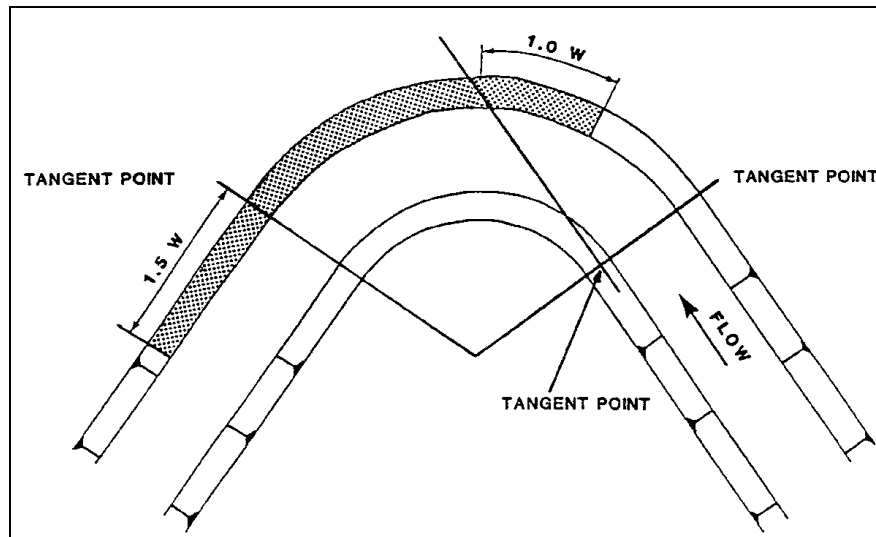

Figure 9.1. Extent of protection required at a channel bend (after USACE).⁽⁴⁾

9.2 DESIGN CONSIDERATIONS

Spur design includes setting the limits of bank protection required; selection of the spur type to be used; and design of the spur installation including spur length, orientation, permeability, height, profile, and spacing.

9.2.1 Longitudinal Extent of Spur Field

The longitudinal extent of channel bank requiring protection is discussed in Brown.^(2,3) Figure 9.1 was developed from USACE studies of the extent of protection required at meander bends.⁽⁴⁾ The minimum extent of bank protection determined from Figure 9.1 should be adjusted according to field inspections to determine the limits of active scour, channel surveys at low flow, and aerial photography and field investigations at high flow. Investigators of field installations of bank protection have found that protection commonly extends farther upstream than necessary and not far enough downstream. However, such protection may have been necessary at the time of installation. The lack of a sufficient length of protection downstream is generally more serious, and the downstream movement of meander bends should be considered in establishing the downstream extent of protection.

9.2.2 Spur Length

Spur length is taken here as the projected length of spur normal to the main flow direction or from the bank. Where the bank is irregular, spur lengths must be adjusted to provide for an even curvature of the thalweg. The length of both permeable and impermeable spurs relative to channel width affects local scour depth at the spur tip and the length of bank protected. Laboratory tests indicate that diminishing returns are realized from spur lengths greater than 20 percent of channel width. The length of bank protected measured in terms of projected spur length is essentially constant up to spur lengths of 20 percent of channel width for permeable and impermeable spurs. Field installations of spurs have been successful with lengths from 3 to 30 percent of channel width. Impermeable spurs are usually installed with lengths of less than 20 percent while permeable spurs have been successful with lengths up to 25 percent of channel width. However, only the most permeable spurs were effective at greater lengths.

The above discussion assumes that stabilization of the bend is the only objective when spur lengths are selected. It also assumes that the opposite bank will not erode. Where flow constriction or changing the flow path is also an objective, spur lengths will depend on the degree of constriction required or the length of spur required to achieve the desired change in flow path. At some locations, channel excavation on the inside of the bend may be required where spurs would constrict the flow excessively. However, it may be acceptable to allow the stream to do its own excavation if it is located in uniformly graded sand

9.2.3 Spur Orientation

Spur orientation refers to spur alignment with respect to the direction of the main flow current in a channel. Figure 9.2 defines the spur angle such that an acute spur angle means that the spur is angled in a downstream direction and an angle greater than 90° indicates that the spur is oriented in a upstream direction.

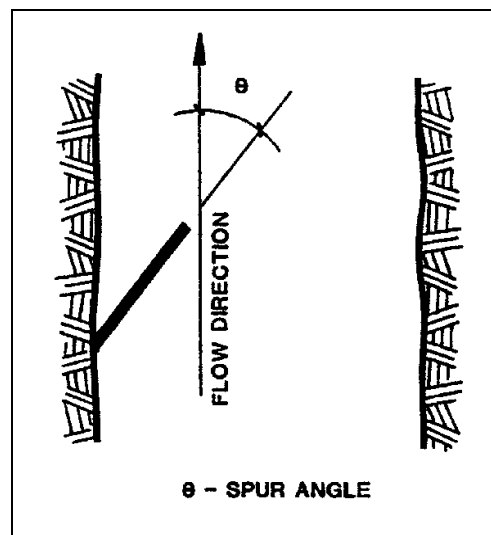

Figure 9.2. Definition sketch for spur angle (after Karaki).⁽⁵⁾

Permeable retarder spurs are usually designed to provide flow retardance near the streambank, and they perform this function equally as well without respect to the spur angle. Since spurs oriented normal to the bank and projecting a given length into the channel are shorter than those at any other orientation, all retarder spurs should be constructed at 90° with the bank for reasons of economy.

No consensus exists regarding the orientation of permeable retarder/deflector spurs and impermeable deflector spurs. There is some agreement that spurs oriented in an upstream direction do not protect as great a length of channel bank downstream of the spur tip, result in greater scour depth at the tip, and have a greater tendency to accumulate debris and ice.

Spur orientation at approximately 90° has the effect of forcing the main flow current (thalweg) farther from the concave bank than spurs oriented in an upstream or downstream direction. Therefore, more positive flow control is achieved with spurs oriented approximately normal to the channel bank. Spurs oriented in an upstream direction cause greater scour than if oriented normal to the bank, and spurs oriented in a downstream direction cause less scour.

It is recommended that the spur furthest upstream be angled downstream to provide a smoother transition of the flow lines near the bank and to minimize scour at the nose of the leading spur. Subsequent spurs downstream should all be set normal to the bank line to minimize construction costs.

Figure 9.3 can be used to adjust scour depth for orientation. It should be noted that permeability also affects scour depth. A method to adjust scour depth for permeability is presented in the following section.

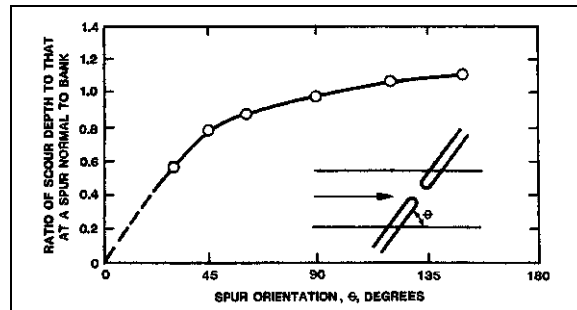

Figure 9.3. Scour adjustment for spur orientation (modified from HDS 6).⁽⁶⁾

The lateral extent of scour can be determined from the depth of scour and the natural angle of repose of the bed material (see HEC-18).⁽⁷⁾

The expansion angle downstream of a spur, i.e., the angle of flow expansion downstream of the contraction at the spur is about 17° for impermeable spurs for all spur angles. The implication is that spur orientation affects the length of bank protected only because of the projected length of the spur along the channel bank.

9.2.4 Spur Permeability

The permeability of the spur depends on stream characteristics, the degree of flow retardance and velocity reduction required, and the severity of the channel bend. Impermeable spurs can be used on sharp bends to divert flow away from the outer bank. Where bends are mild and only small reductions in velocity are necessary, highly permeable retarder spurs can be used successfully. However, highly permeable spurs can also provide required bank protection under more severe conditions where vegetation and debris will reduce the permeability of the spur without destroying the spur. This is acceptable provided the bed load transport is high.

Scour along the streambank and at the spur tip are also influenced by the permeability of the spur. Impermeable spurs, in particular, can create erosion of the streambank at the spur root. This can occur if the crest of impermeable spurs are lower than the height of the bank. Under submerged conditions, flow passes over the crest of the spur generally perpendicular to the spur as illustrated in Figure 9.4. Laboratory studies of spurs with permeability greater than about 70 percent were observed to cause very little bank erosion, while spurs with permeability of 35 percent or less caused bank erosion similar to the effect of impermeable spurs.⁽⁶⁾

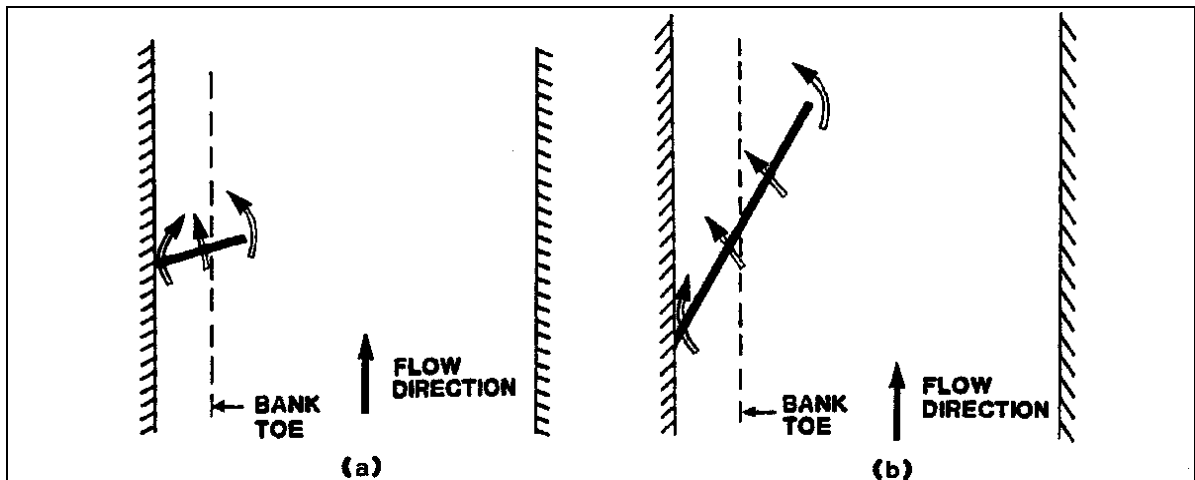

Figure 9.4. Flow components in the vicinity of spurs when the crest is submerged (after Brown).⁽⁸⁾

Permeability up to about 35 percent does not affect the length of channel bank protected by the spur. Above a permeability of 35 percent, the length of bank protected decreases with increasing permeability. Figure 9.5 shows the results of laboratory tests of the effects of permeability and orientation on the expansion angle of flow downstream of spurs. For this figure, spur lengths were 20 percent of the channel width projected normal to the bank.⁽⁸⁾

From the above discussion, it is apparent that spurs of varying permeability will provide protection against meander migration. Impermeable spurs provide more positive flow control but cause more scour at the toe of the spur and, when submerged, cause erosion of the streambank. High permeability spurs are suitable for use where only small reductions in flow velocities are necessary as on mild bends but can be used for more positive flow control where it can be assumed that clogging with small debris will occur and bed load transport is large. Spurs with permeability up to about 35 percent can be used in severe conditions but permeable spurs may be susceptible to damage from large debris and ice.

9.2.5 Spur Height and Crest Profile

Impermeable spurs are generally designed not to exceed the bank height because erosion at the end of the spur in the overbank area could increase the probability of outflanking at high stream stages. Where stream stages are greater than or equal to the bank height, impermeable spurs should be equal to the bank height. If flood stages are lower than the bank height, impermeable spurs should be designed so that overtopping will not occur at the bank. Bank erosion is more severe if the spur is oriented in the downstream direction.

The crest of impermeable spurs should slope downward away from the bank line, because it is difficult to construct and maintain a level spur of rock or gabions. Use of a sloping crest will avoid the possibility of overtopping at a low point in the spur profile, which could cause damage by particle erosion or damage to the streambank.

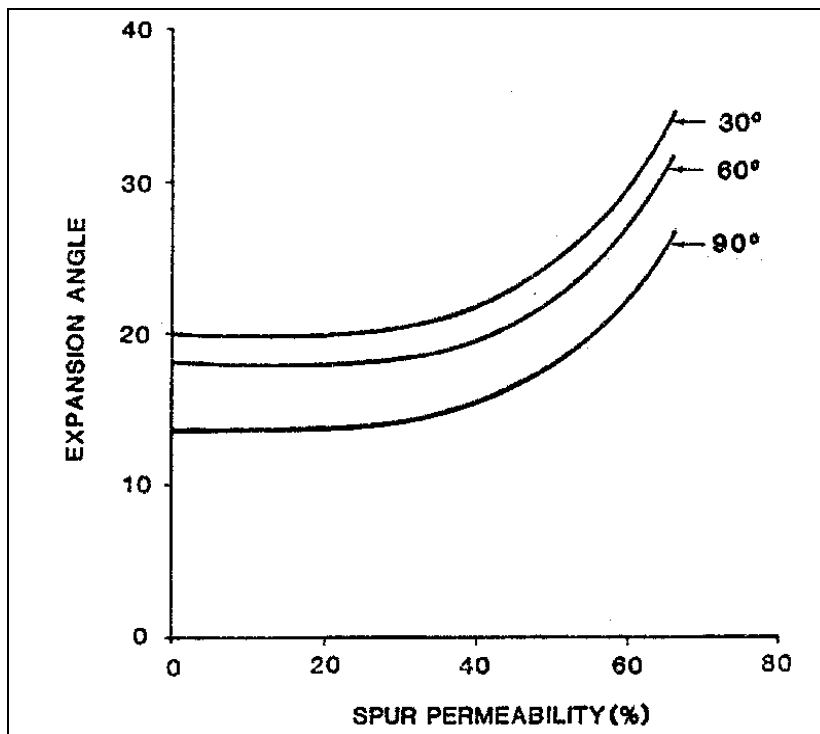

Figure 9.5. Spur permeability and spur orientation vs. expansion angle (after Brown).⁽⁸⁾

Permeable spurs, and in particular those constructed of light wire fence, should be designed to a height that will allow heavy debris to pass over the top. However, highly permeable spurs consisting of jacks or tetrahedrons are dependent on light debris collecting on the spur to make them less permeable. The crest profile of permeable spurs is generally level except where bank height requires the use of a sloping profile.

9.2.6 Bed and Bank Contact

The most common causes of spur failure are undermining and outflanking by the stream. These problems occur primarily in alluvial streams that experience wide fluctuations in the channel bed. Impermeable rock riprap spurs and gabion spurs can be designed to counter erosion at the toe by providing excess material on the streambed as illustrated in Figures 9.6 and 9.7. As scour occurs, excess material is launched into the scour hole, thus protecting the end of the spur. Gabion spurs are not as flexible as riprap spurs and may fail in very dynamic alluvial streams.

Permeable spurs can be similarly protected as illustrated in Figure 9.8. The necessity for using riprap on the full length of the spur or any riprap at all is dependent on the erodibility of the streambed, the distance between the slats and the streambed, and the depth to which the piling are driven. The measure illustrated would also be appropriate as a retrofit measure at a spur that has been severely undermined, and as a design for locations at which severe erosion of the toe of the streambank is occurring.

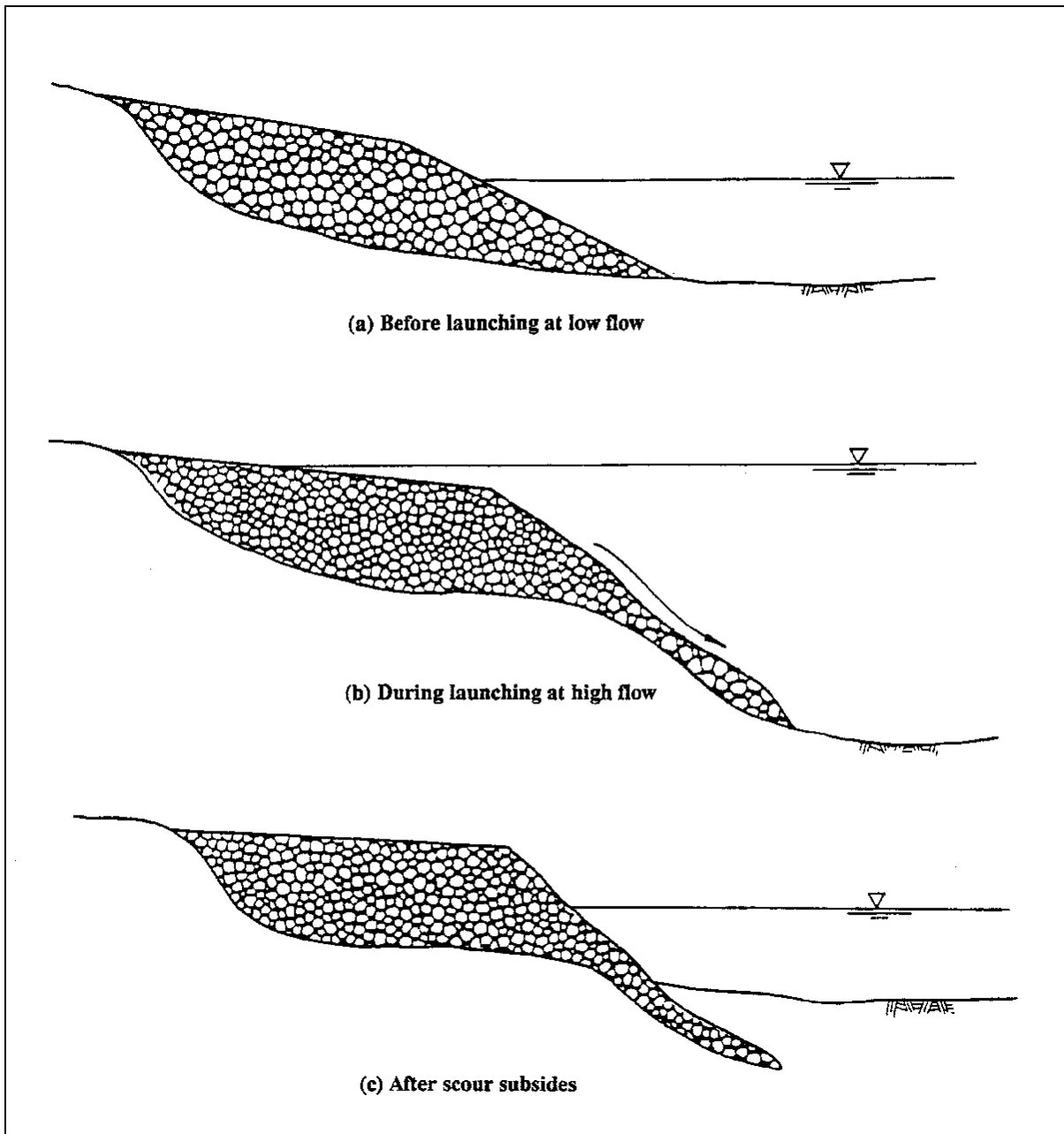

Figure 9.6. Launching of stone toe protection on a riprap spur: (a) before launching at low flow, (b) during launching at high flow, and (c) after scour subsides (after Brown).⁽⁸⁾

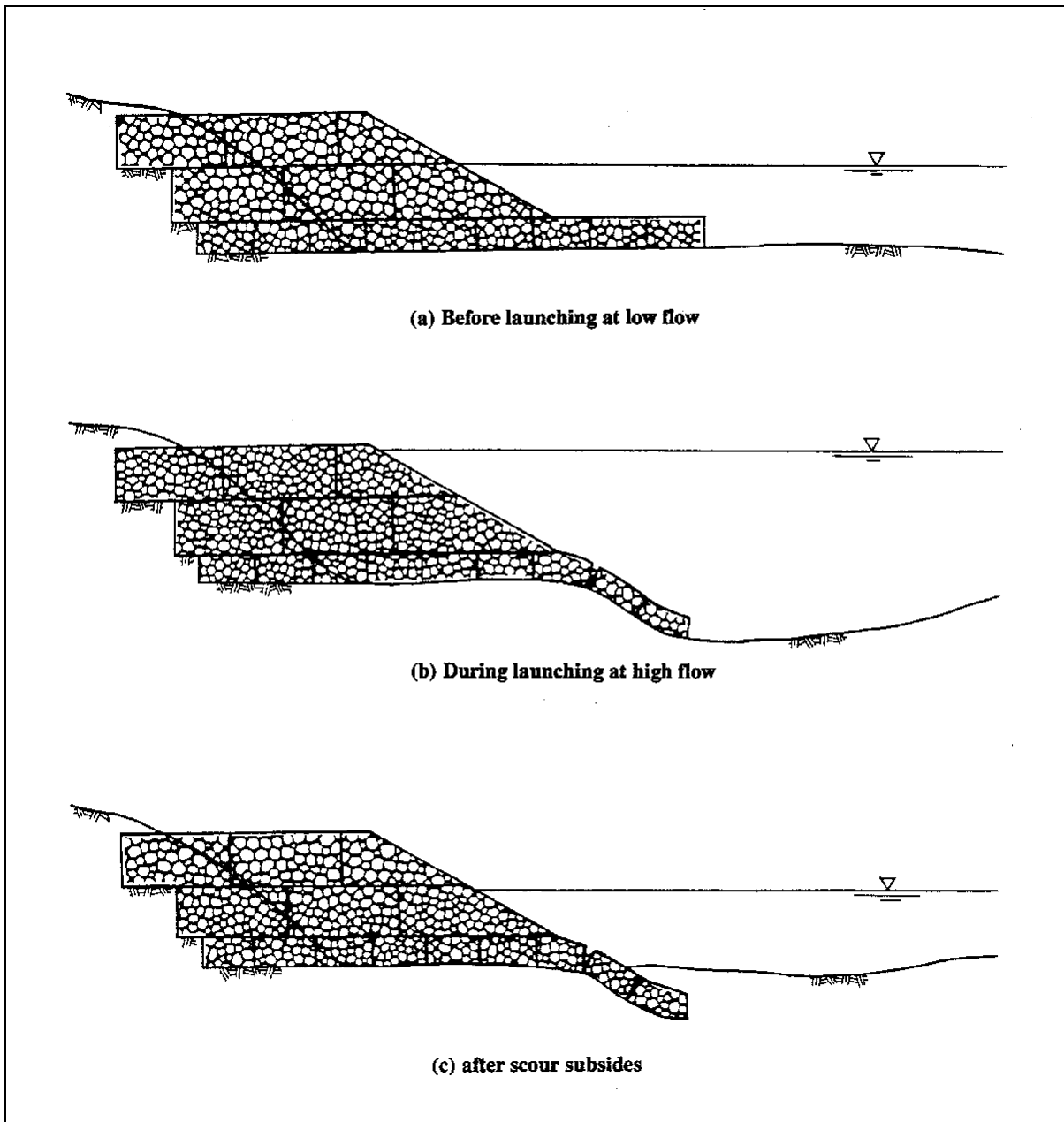

Figure 9.7. Gabion spur illustrating flexible mat tip protection: (a) before launching at low flow, (b) during launching at high flow, and © after scour subsides (after Brown).⁽⁸⁾

Piles supporting permeable structures can also be protected against undermining by driving piling to depths below the estimated scour. Round piling are recommended because they minimize scour at their base.

Extending the facing material of permeable spurs below the streambed also significantly reduces scour. If the retarder spur or retarder/deflector spur performs as designed, retardance and diversion of the flow within the length of the structure may make it unnecessary to extend the facing material the full depth of anticipated scour except at the nose.

A patented Henson spur, as illustrated in Figure 9.9, maintains contact with the streambed by vertical wood slats mounted on pipes which are driven to depths secure from scour. The units slide down the pipes where undermining occurs. Additional units can be added on top as necessary.

9.2.7 Spur Spacing

Spur spacing is a function of spur length, spur angle, permeability, and the degree of curvature of the bend. The flow expansion angle, or the angle at which flow expands toward the bank downstream of a spur, is a function of spur permeability and the ratio of spur length to channel width. This ratio is susceptible to alteration by excavation on the inside of the bend or by scour caused by the spur installation. Figure 9.10 indicates that the expansion angle for impermeable spurs is an almost constant 17° . Spurs with 35 percent permeability have almost the same expansion angle except where the spur length is greater than about 18 percent of the channel width.

As permeability increases, the expansion angle increases, and as the length of spurs relative to channel width increases, the expansion angle increases exponentially. The expansion angle varies with the spur angle, but not significantly.

Spur spacing in a bend can be established by first drawing an arc representing the desired flow alignment (Figure 9.11). This arc will represent the desired extreme location of the thalweg nearest the outside bank in the bend. The desired flow alignment may differ from existing conditions or represent no change in conditions, depending on whether there is a need to arrest erosion of the concave bank or reverse erosion that has already occurred. If the need is to arrest erosion, permeable retarder spurs or retarder structures may be appropriate. If the flow alignment must be altered in order to reverse erosion of the bank or to alter the flow alignment significantly, deflector spurs or retarder/deflector spurs are appropriate. The arc representing the desired flow alignment may be a compound circular curve or any curve which forms a smooth transition in flow directions.

Next, draw an arc representing the desired bankline. This may approximately describe the existing concave bank or a new theoretical bankline which protects the existing bank from further erosion. Also, draw an arc connecting the nose (tip) of spurs in the installation. The distance from this arc to the arc describing the desired bank line, along with the expansion angle, fixes the spacing between spurs. The arc describing the ends of spurs projecting into the channel will be essentially concentric with the arc describing the desired flow alignment.

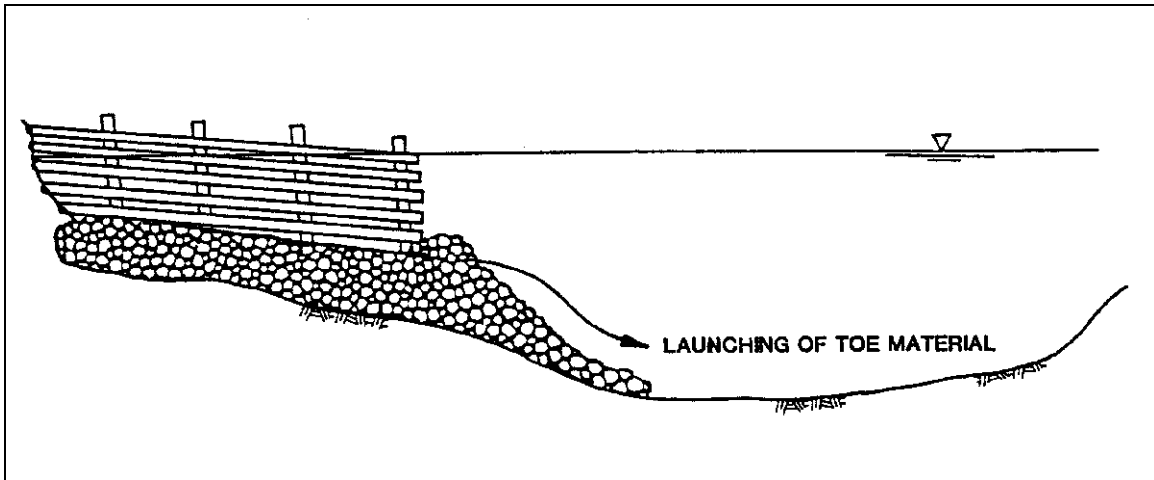

Figure 9.8. Permeable wood-slat fence spur showing launching of stone toe material (after Brown).⁽⁸⁾

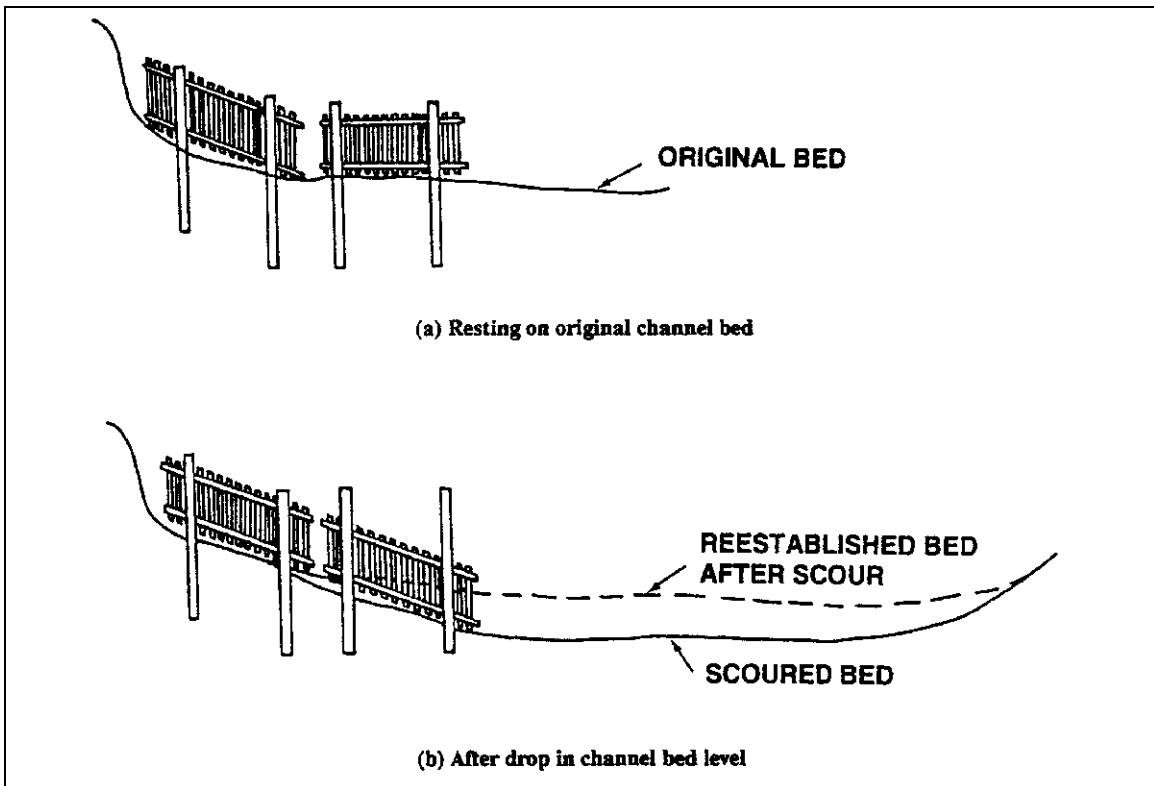

Figure 9.9. Henson spurs (a) resting on original channel bed, and (b) after drop in channel bed level (after Brown).⁽⁸⁾

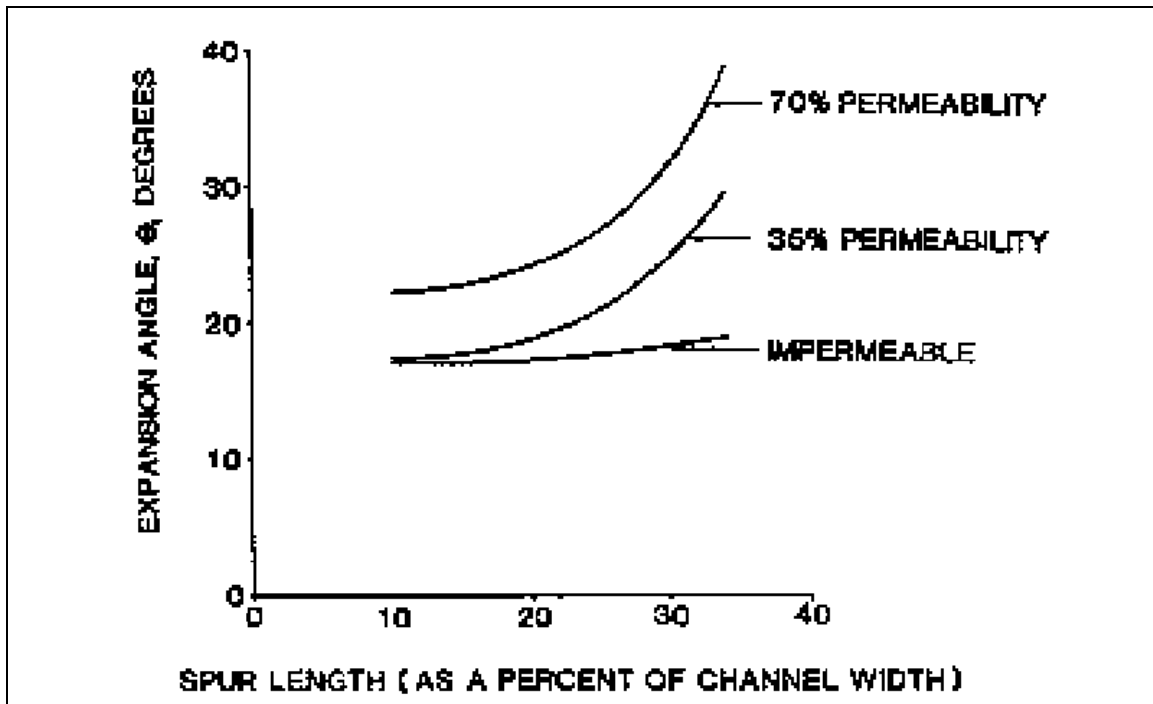

Figure 9.10. Relationship between spur length and expansion angle for several spur permeabilities (after Brown).⁽⁸⁾

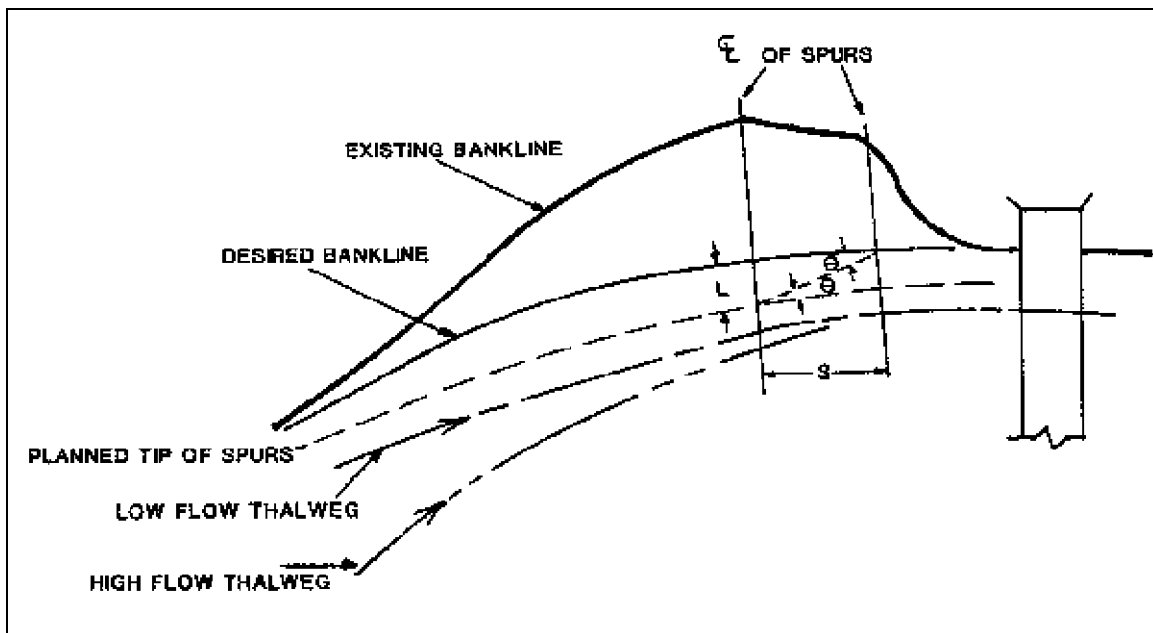

Figure 9.11. Spur spacing in a meander bend (after Brown).⁽⁸⁾

Establish the location of the spur at the downstream end of the installation. For a highway application, this is normally the protected abutment or guidebank at the bridge. Finally, establish the spacing between each of the remaining spurs in the installation (Figure 9.11). The distance between spurs, S , is the length of spur, L , between the arc describing the desired bank line and the nose of the spur multiplied by the cotangent of the flow expansion angle, θ . This length is the distance between the nose of spurs measured along a chord of the arc describing spur nose location. Remaining spurs in the installation will be at the same spacing if the arcs are concentric. The procedure is illustrated by Figure 9.11 and expressed in Equation 9.1.

$$S=L \cot \theta \quad (9.1)$$

where:

- S = spacing between spurs at the nose, m (ft)
- L = effective length of spur, or the distance between arcs describing the toe of spurs and the desired bank line, m (ft)
- θ = expansion angle downstream of spur nose, degrees

At less than bankfull flow rates, flow currents may approach the concave bank at angles greater than those estimated from Figure 9.10. Therefore, spurs should be well-anchored into the existing bank, especially the spur at the upstream end of the installation, to prevent outflanking.

9.2.8 Shape and Size of Spurs

In general, straight spurs should be used for most bank protection. Straight spurs are more easily installed and maintained and require less material. For permeable spurs, the width depends on the type of permeable spur being used. Less permeable retarder/deflector spurs which consist of a soil or sand embankment should be straight with a round nose as shown in Figure 9.12.

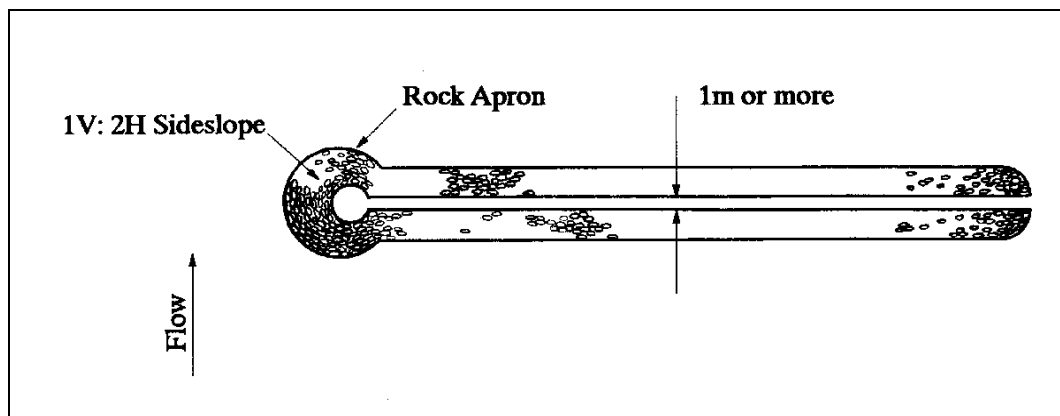

Figure 9.12. Typical straight, round nose spur.

The top width of embankment spurs should be a minimum of 1 m (3 ft.). However, in many cases the top width will be dictated by the width of any earth moving equipment used to construct the spur. In general a top width equal to the width of a dump truck can be used. The side slopes of the spur should be 1V:2H or flatter.

9.2.9 Riprap

Rock riprap should be placed on the upstream and downstream faces as well as on the nose of the spur to inhibit erosion of the spur. Depending on the embankment material being used, a gravel, sand, or geotextile may be required (see HEC-11).⁽³⁾ The designer is referred to HDS 6, HEC-11, HEC-18, and Design Guideline 12 for design procedures for sizing riprap at spurs.^(6,3,7)

It is recommended that riprap be extended below the bed elevation to a depth as recommended in HEC-11⁽³⁾ and Design Guideline 12 (to the combined long-term degradation and contraction scour depth). Riprap should also extend to the crest of the spur, in cases where the spur would be submerged at design flow, or to 0.6 m (2 ft.) above the design flow, if the spur crest is higher than the design flow depth. Additional riprap should be placed around the nose of the spur (Figure 9.14), so that spur will be protected from scour. Figure 9.13 shows an example of an impermeable spur field and a close-up of a typical round nose spur installation.

9.3 DESIGN EXAMPLE OF SPUR INSTALLATION

Figure 9.14 illustrates a location at which a migrating bend threatens an existing bridge (existing conditions are shown with a solid line). Ultimately, based upon the following design example, seven spurs will be required. Although the number of spurs is not known in advance, the spurs (and other design steps) are shown as dashed lines on Figure 9.14 as they will be specified after completing the following design example. Assume that the width of the river from the desired (north) bankline to the existing (south) bankline is 50 m (164 ft).

For this example, it is desirable to establish a different flow alignment and to reverse erosion of the concave (outside) bank. The spur installation has two objectives: (1) to stop migration of the meander before it damages the highway stream crossing, and (2) to reduce scour at the bridge abutment and piers by aligning flow in the channel with the bridge opening. Impermeable deflector spurs are suitable to accomplish these objectives and the stream regime is favorable for the use of this type of countermeasure. The expansion angle for this spur type is approximately 17° for a spur length of about 20 percent of the desired channel width, as indicated in Figure 9.10.

Step 1. Sketch Desired Thalweg

The first step is to sketch the desired thalweg location (flow alignment) with a smooth transition from the upstream flow direction through the curve to an approach straight through the bridge waterway (Figure 9.14). Visualize both the high-flow and low-flow thalwegs. For an actual location, it would be necessary to examine a greater length of stream to establish the most desirable flow alignment. Then draw an arc representing the desired bankline in relation to thalweg locations. The theoretical or desired left bank line is established as a continuation of the bridge abutment and left bank downstream through the curve, smoothly joining the left bank at the upstream extremity of eroded bank.



Figure 9.13. Impermeable spur field in top photograph with close-up shot of one spur in the lower photograph, vicinity of the Richardson Highway, Delta River, Alaska.

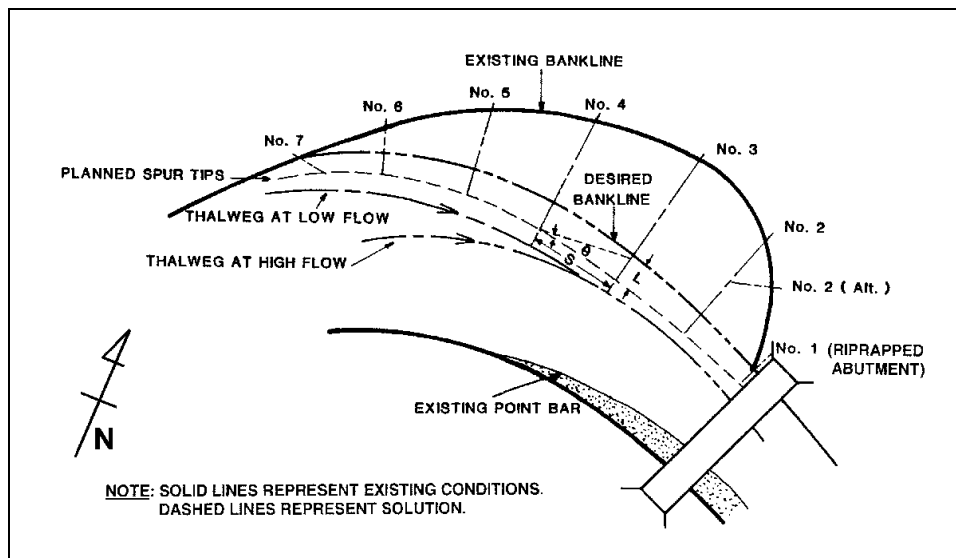

Figure 9.14. Example of spur design.

Step 2. Sketch Alignment of Spur Tips

The second step is to sketch a smooth curve through the nose (tip) locations of the spurs, concentric with the desired bankline alignment. Using a guideline of 20% of the desired channel width for impermeable spurs (see Section 9.2.2) the distance, L , from the desired bankline to the spur tips (Figure 9.14) would be:

$$L = .20(50 \text{ m}) = 10 \text{ m (SI)}$$

$$L = .20(164 \text{ ft}) = 33 \text{ ft (English)}$$

Step 3. Locate First Spur

Step number three is to locate spur number 1 so that flow expansion from the nose of the spur will intersect the streambank downstream of the abutment. This is accomplished by projecting an angle of 17° from the abutment alignment to an intersection with the arc describing the nose of spurs in the installation or by use of Equation 9.1. Spurs are set at 90° to a tangent with the arc for economy of construction. Alternatively, the first spur could be considered to be either the upstream end of the abutment or guide bank if the spur field is being installed upstream of a bridge. Thus, the spur spacing, S , would be:

$$S = L \cot \theta = (10 \text{ m}) \cot 17^\circ = 33 \text{ m (SI)}$$

$$S = L \cot \theta = (33 \text{ ft}) \cot 17^\circ = 108 \text{ ft (English)}$$

It may be desirable to place riprap on the streambank at the abutment. Furthermore, the size of the scour hole at the spur directly upstream of the bridge should be estimated using the procedures described in Chapter 4. If the extent of scour at this spur overlaps local scour at the pier, total scour depth at the pier may be increased. This can be determined by extending the maximum scour depth at the spur tip, up to the existing bed elevation at the pier at the angle of repose.

Step 4. Locate Remaining Spurs

Spurs upstream of spur number 1 are then located by use of Equation 9.1, using dimensions as illustrated in Figure 9.11 (i.e., the spacing, S , determined in Step 3). Using this spur spacing, deposition will be encouraged between the desired bank line and the existing eroded bank.

The seventh and last spur upstream is shown oriented in a downstream direction to provide a smooth transition of the flow approaching the spur field. This spur could have been oriented normal to the existing bank, and been shorter and more economical, but might have caused excessive local scour. Orienting the furthest upstream spur at an angle in the downstream direction provides a smoother transition into the spur field, and decreases scour at the nose of the spur. As an alternative, a hard point could be installed where the bank is beginning to erode. Hard points are discussed in Chapter 6. In this case the hard point can be considered as a very short spur which is located at the intersection of the actual and planned bank lines. In either case, spurs or hard points should be anchored well into the bank to prevent outflanking.

9.4 REFERENCES

1. Brown, S.A., 1985, "Streambank Stabilization Measures for Highway Stream Crossings—Executive Summary," FHWA/RD-84/099, Federal Highway Administration, Washington, D.C.
2. Brown, S.A., 1985, "Streambank Stabilization Measures for Highway Engineers," FHWA/RD-84.100 Federal Highway Administration, McLean, VA.
3. Brown, S.A. and E.S. Clyde, 1989, "Design of Riprap Revetment," Hydraulic Engineering Circular No.11, FHWA-IP-89-016. Prepared for the Federal Highway Administration, Washington, D.C.
4. U.S. Army Corps of Engineers, 1981, "The Streambank Erosion Control Evaluation and Demonstration Act of 1974," Final Report to Congress, Executive Summary and Conclusions.
5. Karaki, S.S., 1959, "Hydraulic Model Study of Spur Dikes for Highway Bridge Openings," Colorado State University, Civil Engineering Section, Report CER59SSK36, September, 47 pp.
6. Richardson, E.V., D.B. Simons, and P.F. Lagasse, 2001, "River Engineering for Highway Encroachments - Highways in the River Environment," Report No. FHWA NHI 01-004, Hydraulic Design Series No. 6, Federal Highway Administration, Washington, D.C.
7. Richardson, E.V. and S.R. Davis, 2000, "Evaluating Scour at Bridges," Report FHWA NHI 01-001, Federal Highway Administration, Hydraulic Engineering Circular No. 18, U.S. Department of Transportation, Washington, D.C.
8. Brown, S.A., 1985, "Design of Spur-Type Streambank Stabilization Structures, Final Report," FHWA/RD-84-101, Federal Highway Administration, Washington, D.C.

(page intentionally left blank)

DESIGN GUIDELINE 10
GUIDE BANKS

(page intentionally left blank)

DESIGN GUIDELINE 10

GUIDE BANKS

10.1 BACKGROUND

When embankments encroach on wide flood plains, the flows from these areas must flow parallel to the approach embankment to the bridge opening. These flows can erode the approach embankment. A severe flow contraction at the abutment can reduce the effective bridge opening, which could possibly increase the severity of abutment and pier scour.

Guide banks (formerly known as spur dikes) can be used in these cases to prevent erosion of the approach embankments by cutting off the flow adjacent to the embankment, guiding streamflow through a bridge opening, and transferring scour away from abutments to prevent damage caused by abutment scour. The two major enhancements guide banks bring to bridge design are (1) reduce the separation of flow at the upstream abutment face and thereby maximize the use of the total bridge waterway area, and (2) reduce the abutment scour due to lessening turbulence at the abutment face. Guide banks can be used on both sand- and gravel-bed streams.

Principal factors to be considered when designing guide banks, are their orientation to the bridge opening, plan shape, upstream and downstream length, cross-sectional shape, and crest elevation. Bradley is used as the principal design reference for this section.⁽¹⁾

Figure 10.1 presents a typical guide bank plan view. It is apparent from the figure that without this guide bank overbank flows would return to the channel at the bridge opening, which can increase the severity of contraction and scour at the abutment. Note, that with installation of guide banks the scour holes which normally would occur at the abutments of the bridge are moved upstream away from the abutments. Guide banks may be designed at each abutment, as shown, or singly, depending on the amount of overbank or flood plain flow directed to the bridge by each approach embankment.

The goal in the design of guide banks is to provide a smooth transition and contraction of the streamflow through the bridge opening. Ideally, the flow lines through the bridge opening should be straight and parallel. As in the case with other countermeasures, the designer should consider the principles of river hydraulics and morphology, and exercise sound engineering judgment.

10.2 DESIGN GUIDELINES

10.2.1 Orientation

Guide banks should start at and be set parallel to the abutment and extend upstream from the bridge opening. If there are guide banks at each abutment, the distance between them at the bridge opening should be equal to the distance between bridge abutments. Best results are obtained by using guide banks with a plan form shape in the form of a quarter of an ellipse, with the ratio of the major axis (length L_s) to the minor axis (offset) of IV:2.5H. This allows for a gradual constriction of the flow. Thus, if the length of the guide bank measured perpendicularly from the approach embankment to the upstream nose of the guide bank is denoted as L_s , the amount of expansion of each guide bank (offset), measured from the abutment parallel to the approach roadway, should be $0.4 L_s$.

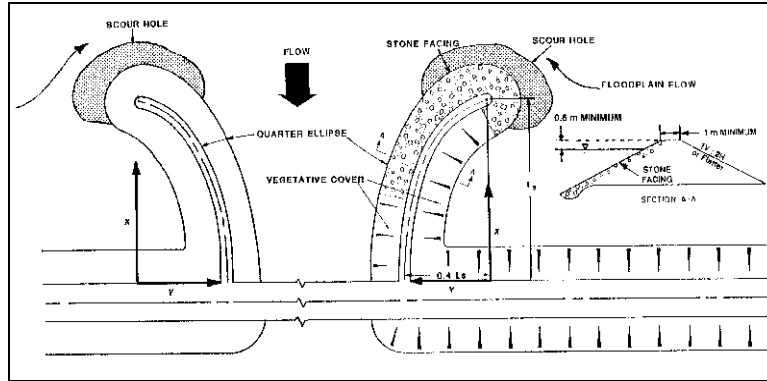

Figure 10.1. Typical guide bank (modified from Bradley).⁽¹⁾

The plan view orientation can be determined using Equation 10.1, which is the equation of an ellipse with origin at the base of the guide bank. For this equation, X is the distance measured perpendicularly from the bridge approach and Y is the offset measured parallel to the approach embankment, as shown on Figure 10.1.

$$\frac{X^2}{L_s^2} + \frac{Y^2}{(0.4L_s)^2} = 1 \quad (10.1)$$

It is important that the face of the guide bank match the abutment so that the flow is not disturbed where the guide bank meets the abutment. For new bridge construction, abutments can be sloped to the channel bed at the same angle as the guide bank. For retrofitting existing bridges modification of the abutments or wing walls may be necessary.

10.2.2 Length

For design of guide banks, the length of the guide bank, L_s must first be determined. This can be easily determined using a nomograph which was developed from laboratory tests performed at Colorado State University and from field data compiled by the USGS.^(2,3,4) For design purposes the use of the nomograph involves the following parameters:

- Q = total discharge of the stream, m³/s (ft³/s)
- Q_f = lateral or flood plain discharge of either flood plain **intercepted by the embankment**, m³/s (cfs) (ft³/s)
- Q_A = discharge in 30 m (100 ft) of stream adjacent to the abutment, m³/s (ft³/s)
- b = length of the bridge opening, m (ft)
- A_{n2} = cross-sectional flow area at the bridge opening at normal stage, m² (ft²)
- V_{n2} = $\frac{Q}{A_{n2}}$ = average velocity through the bridge opening, m/s (ft/s)
- $\frac{Q_f}{Q_A}$ = guide bank discharge ratio
- L_s = projected length of guide bank, m (ft)

A nomograph is presented in Figure 10.2 (SI) and Figure 10.3 (English) to determine the projected length of guide banks. This nomograph should be used to determine the guide bank length for designs greater than 15 m (50 ft) and less than 75 m (250 ft). If the nomograph indicates the length required to be greater than 75 m (250 ft) the design should be set at 75 m (250 ft). It is recommended that the minimum length of guide banks be 15 m (50 ft). An example of how to use this nomograph is presented in the next section.

FHWA practice has shown that many guide banks have performed well using a standardized length of 46 m (150 ft). Based on this experience, guide banks of 46 m (150 ft) in length should perform very well in most locations. Even shorter guide banks have been successful if the guide bank intersects the tree line. If the main channel is equal to or less than 30 m (100 ft) use the total main channel flow in determining the guide bank discharge ratio (Q_f/Q_A).

10.2.3 Crest Height

As with deflection spurs, guide banks should be designed so that they will not be overtopped at the design discharge. If this were allowed to occur, unpredictable cross flows and eddies might be generated, which could scour and undermine abutments and piers. In general, a minimum of 0.6 m (2 ft) of freeboard, above the design water surface elevation should be maintained.

10.2.4 Shape and Size

The cross-sectional shape and size of guide banks should be similar to deflector, or deflector/retarder spurs discussed in Design Guideline 9. Generally, the top width is 3 to 4 m (10 to 13 ft), but the minimum width is 1 m (3 ft) when construction is by drag line. The upstream end of the guide bank should be round nosed. Side slopes should be 1V:2H or less.

10.2.5 Downstream Extent

In some states, highway departments extend guide banks downstream of the abutments to minimize scour due to rapid expansion of the flow at the downstream end of the abutments. These downstream guide banks are sometimes called "heels." If the expansion of the flow is too abrupt, a shorter guide bank, which usually is less than 15 m (50 ft) long, can be used downstream. Downstream guide banks should also start at and start parallel to the abutment and the distance between them should enlarge as the distance from the abutment of the bridge increases.

In general, downstream guide banks are a shorter version of the upstream guide banks. Riprap protection, crest height and width should be designed in the same manner as for upstream guide banks.

10.2.6 Riprap

Guide banks are constructed by forming an embankment of soil or sand extending upstream from the abutment of the bridge. To inhibit erosion of the embankment materials, guide banks must be adequately protected with riprap or stone facing.

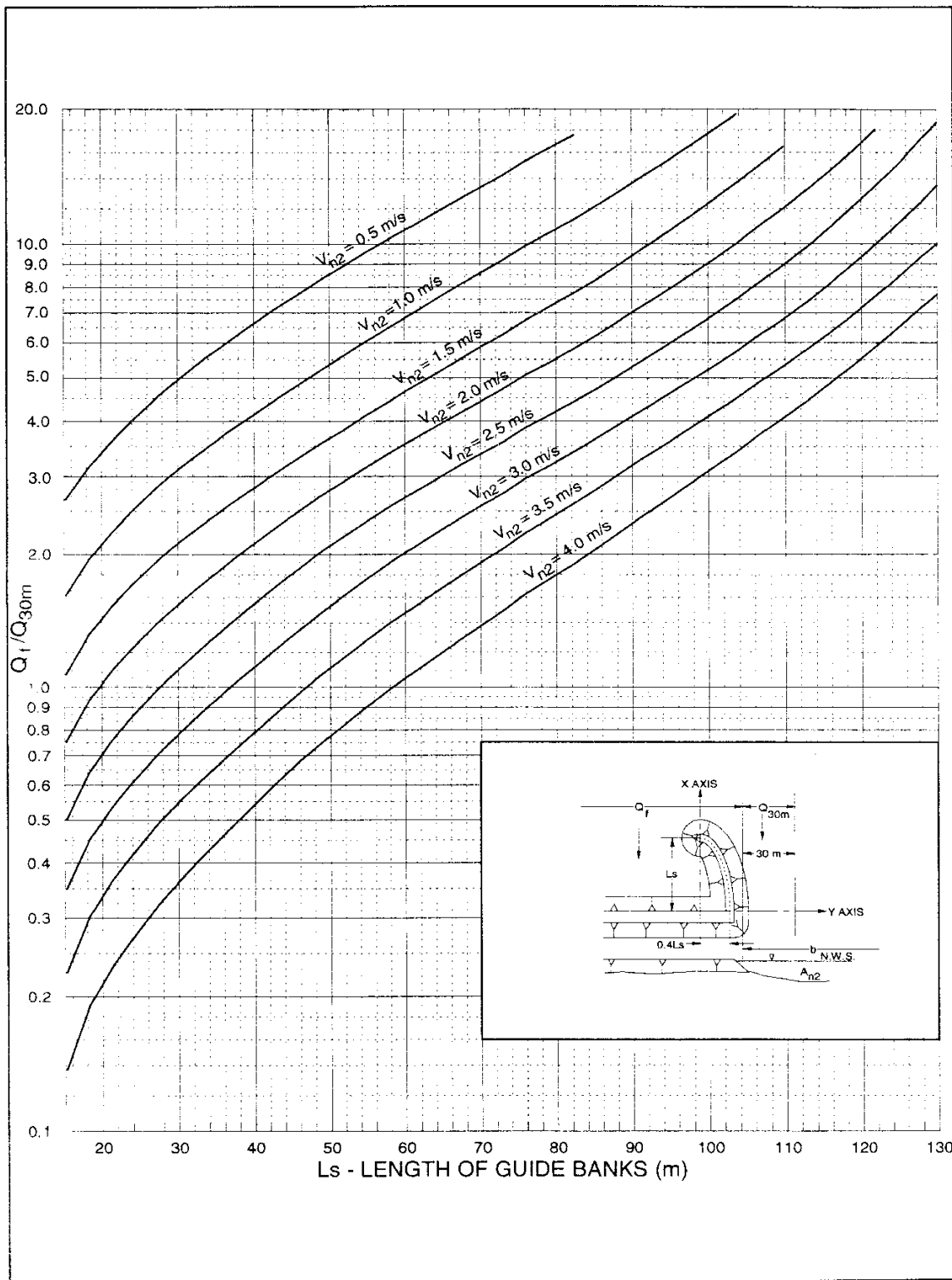

Figure 10.2. SI nomograph to determine guide bank length (after Bradley).⁽¹⁾

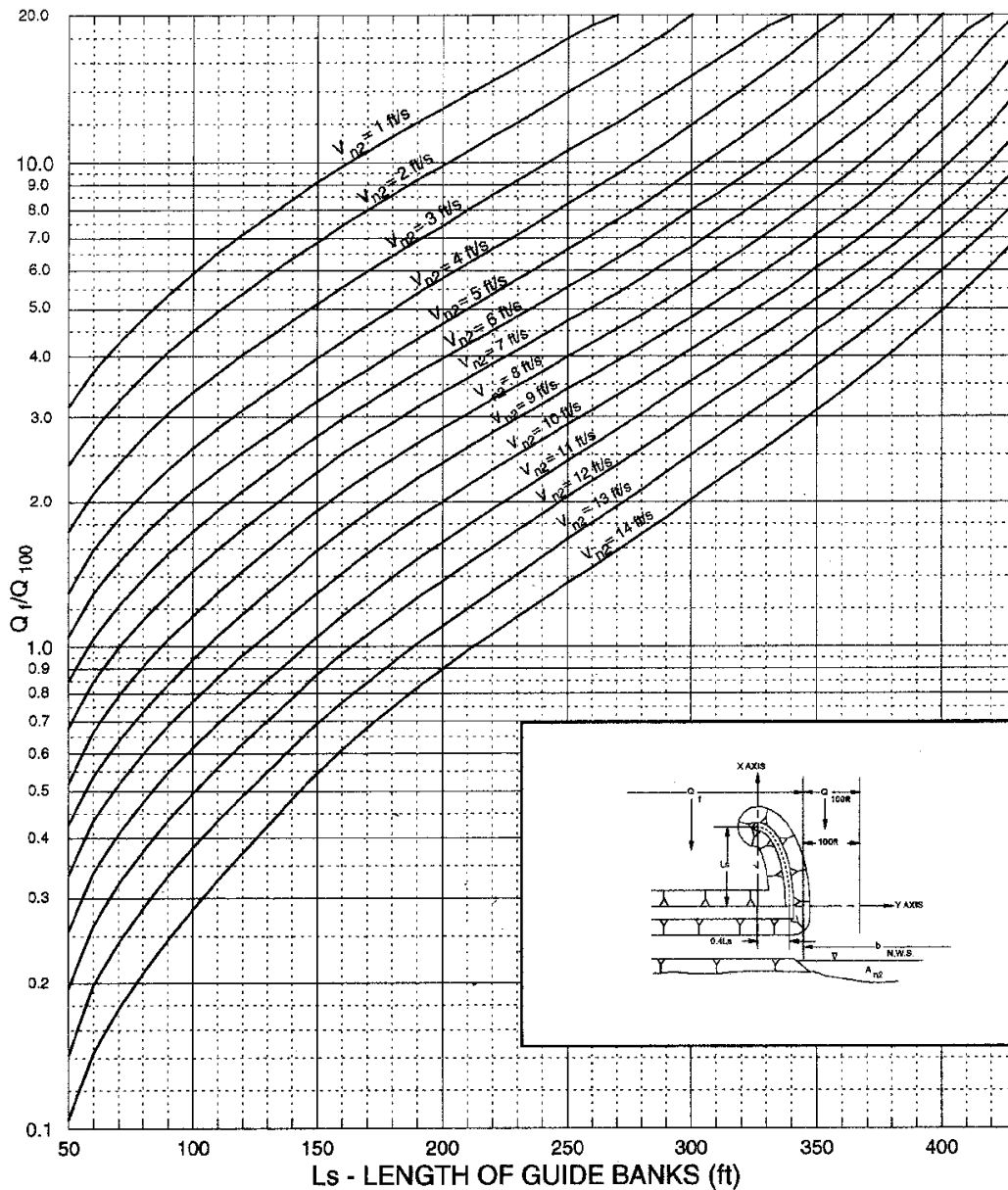

Figure 10.3. English version of nomograph to determine guidebank length (after Bradley).⁽¹⁾

Rock riprap should be placed on the stream side face as well as around the end of the guide bank. It is not necessary to riprap the side of the guide bank adjacent to the highway approach embankment. As in the case of spurs, a gravel, sand, or geotextile filter may be required to protect the underlying embankment material (see HEC-11)⁽⁵⁾ and Design Guideline 12. The designer is referred to HDS 6⁽⁶⁾ or Design Guideline 12 for design procedures for sizing riprap. Riprap should be extended below the bed elevation to a depth as recommended in HEC-11 and Design Guideline 12 (below the combined long-term degradation and contraction scour depth), and extend up the face of the guide bank to 0.6 m (2 ft) above the design flow.⁽⁵⁾ Additional riprap should be placed around the upstream end of the guide bank so to protect the embankment from scour.

As in the case of spurs, it is important to adequately tie guide banks into the approach embankment for guide banks on non-symmetrical highway crossings. Hydraulics of Bridge Waterways⁽¹⁾ states:

"From meager testing done to date, there is not sufficient evidence to warrant using longer dikes (guide banks) at either abutment on skewed bridges. Lengths obtained from [the nomograph] should be adequate for either normal or skewed crossings."

Therefore, for skewed crossings, the length of guide banks should be set using the nomograph for the side of the bridge crossing which yields the largest guide bank length.

10.2.7 Other Design Concerns

In some cases, where the cost of stone riprap facing is prohibitive, the guide bank can be covered with sod or other minimal protection. If this approach is selected, the design should allow for and stipulate the repair or replacement of the guide bank after each high water occurrence. Other measures which will minimize damage to approach embankments, and guide banks during high water are:

- Keep trees as close to the toe of guide bank embankments as construction will permit. Trees will increase the resistance to flow near and around the toe of the embankment, thus reducing velocities and scour potential.
- Do not allow the cutting of channels or the digging of borrow pits along the upstream side of approach embankments and near guide banks. Such practices encourage flow concentration and increases velocities and erosion rates of the embankments.
- In some cases, the area behind the guide bank may be too low to drain properly after a period of flooding. This can be a problem, especially when the guide bank is relatively impervious. Small drain pipes can be installed in the guide bank to drain this ponded water.
- In some cases, only one approach will cut off the overbank flow. This is common when one of the banks is high and well defined. In these cases, only one guide bank may be necessary.

10.3 DESIGN EXAMPLE OF GUIDE BANK INSTALLATION (SI)

For the example design of a guide bank, Figure 10.4 will be used. This figure shows the cross-section of the channel and flood plain before the bridge is constructed and the plan view of the approach, guide banks, and embankments after the design steps outlined below are completed.

Step 1. Hydraulic Design Parameters

The first step in the design of guide banks requires the computation of the depth and velocity of the design flood in the main channel and in the adjacent overbank areas. These studies are performed by using step backwater computations upstream and through the bridge opening. The computer programs WSPRO, HEC-2, or HEC River Analysis System (RAS) are suitable for these computations.^(7,8,9) Using these programs or by using conveyance curves developed from actual data, the discharges and depths in the channel and overbank areas can be determined.

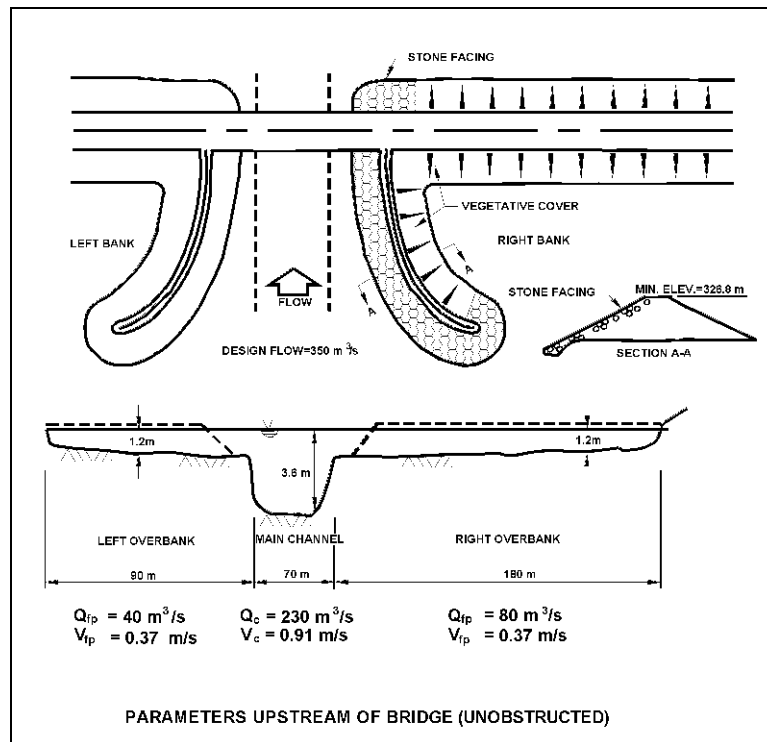

Figure 10.4. Example guide bank design (SI).

To use the conveyance curve approach, the designer is referred to example problem number 4 in *Hydraulics of Bridge Waterways* for methods to determine these discharges and areas.⁽¹⁾ That publication also contains another example of the design of a guide bank.

For this example, the total, overbank, and channel discharges, as well as the flow area are given. We also assume that a bridge will span a channel with a bottom width of 70 m and that **the abutments will be set back 45 m** from each bank of the main channel. The abutments of this bridge are spill-through with a side slope of 1V:2H. The design discharge is 350 m³/s, which after backwater computations, results in a mean depth of 3.6 m in the main channel and a mean channel velocity of 0.91 m/s.

Step 2. Determine Q_f in the Left and Right Overbank

The depth in each overbank area is given as 1.2 m and the widths of the left and right overbank areas are 90 m and 180 m, respectively. Velocity in the overbank areas (assuming no highway approach embankment, i.e., at an upstream cross section) is 0.37 m/s. The floodplain flow is equal to 40 m³/s for the left overbank and 80 m³/s for the right overbank.

Using the continuity equation and noting that the abutments are set back 45 m from each bank, the flood plain discharge intercepted by each approach embankment is:

$$Q = AV$$

$$(Q_f)_{\text{right}} = 80 - (45)(1.2)(.37) = 60 \text{ m}^3/\text{s}$$

$$(Q_f)_{\text{left}} = 40 - (45)(1.2)(.37) = 20 \text{ m}^3/\text{s}$$

Step 3. Determine Q_A and Q_f/Q_A for the Left and Right Overbank

The overbank discharge in the first 30 m of opening adjacent to the left and right abutments needs to be determined next. Since for this case the flow is of uniform depth (1.2 m) and velocity (0.37 m/s) over the entire width of the flood plain, and both abutments are set back more than 30 m from the main channel banks, the value of Q_A will be the same for both sides:

$$(Q_A)_{\text{right}} = (30)(1.2)(.37) = 13.3 \text{ m}^3/\text{s}$$

$$(Q_A)_{\text{left}} = (30)(1.2)(.37) = 13.3 \text{ m}^3/\text{s}$$

For the left and right overbanks the reference values of Q_f/Q_A can be determined by simple division of the discharges determined in previous steps:

$$\left(\frac{Q_f}{Q_A}\right)_{\text{right}} = \frac{60}{13.3} = 4.5$$

$$\left(\frac{Q_f}{Q_A}\right)_{\text{left}} = \frac{20}{13.3} = 1.5$$

For design purposes, the largest value will result in the more conservative determination of the length of the guide banks, except where Step 4 indicates a guide bank is required for only one of the overbank areas.

Step 4. Determine the Length of the Guide Bank, L_s

The average channel velocity through the bridge opening can be determined by dividing the total discharge of the stream, Q , by the cross-sectional flow area at the bridge opening, A_{n2} , which in this case includes the main channel (252 m²) plus 45 m of the left and right overbank areas adjacent to the abutments at the bridge opening (108 m²). Thus:

$$V_{n2} = \frac{Q}{a_{n2}} = \frac{350}{(3.6)(70) + 2(1.2)(45)}$$

$$V_{n2} = 0.97 \text{ m / s}$$

For Q_f/Q_A equal to 4.5 and an average channel velocity of 0.97 m/s, the length of the guide bank is determined using the nomograph presented in Figure 10.2.

$$(L_s)_{\text{right}} = 42 \text{ m}$$

For the left abutment, a Q_f/Q_A of 1.5 and V_{n2} of 0.97 m/s indicate that L_s would be less than 15 m. Thus, no guide bank is required for the left overbank for this example.

Step 5. Miscellaneous Specifications

The offset of the guidebank is determined to be 16.8 m by multiplying L_s by 0.4. The offset and length determine the plan layout of the guide bank. Coordinates of points along the centerline can be determined using Equation 10.1, which is the equation of an ellipse with a major to minor axis ratio of 2.5:1. The coordinates for a 42 m long guide bank with a 16.8 m offset are presented in Table 10.1.

X (m)	Y (m)
0	16.80
10	16.32
20	14.77
30	11.76
42	0.0

These coordinates would be used for conceptual level design. For construction, coordinates at an offset or along the toe of side slope would be necessary.

The crest of the guide bank must be a minimum of 0.6 m above the design water surface (elevation 326.2 m). Therefore, the crest elevation for this example should be greater than or equal to 326.8 m. The crest width should be at least 1 m. For this example, a crest width of 3 m will be specified so that the guide bank can be easily constructed with dump trucks.

Stone or rock riprap should be placed in the locations shown on Figure 10.4. This riprap should extend a minimum of 0.6 m above the design water surface (elevation 326.2 m) and below the intersection of the toe of the guide bank and the existing ground to the combined long-term degradation and contraction scour depth.

10.4 DESIGN EXAMPLE OF GUIDE BANK INSTALLATION (English)

For the example design of a guide bank, Figure 10.5 will be used. This figure shows the cross-section of the channel and flood plain before the bridge is constructed and the plan view of the approach, guide banks, and embankments after the design steps outlined below are completed.

Step 1. Hydraulic Design Parameters

The first step in the design of guide banks requires the computation of the depth and velocity of the design flood in the main channel and in the adjacent overbank areas. These studies are performed by using step backwater computations upstream and through the bridge opening. The computer programs WSPRO, HEC-2, or HEC River Analysis System (RAS) are suitable for these computations.^(7, 8, 9) Using these programs or by using conveyance curves developed from actual data, the discharges and depths in the channel and overbank areas can be determined.

To use the conveyance curve approach, the designer is referred to example problem number 4 in *Hydraulics of Bridge Waterways* for methods to determine these discharges and areas.⁽¹⁾ That publication also contains another example of the design of a guide bank.

For this example, the total, overbank, and channel discharges, as well as the flow area are given. We also assume that a bridge will span a channel with a bottom width of 230 ft and that **the abutments will be set back 148 ft** from each bank of the main channel. The abutments of this bridge are spill-through with a side slope of 1V:2H. The design discharge is 12,360 cfs, which after backwater computations, results in a mean depth of 11.8 ft in the main channel and a mean channel velocity of 3 ft/s.

Step 2. Determine Q_f in the Left and Right Overbank

The depth in each overbank area is given as 3.9 ft and the widths of the left and right overbank areas are 295 ft and 590 ft, respectively. Velocity in the overbank areas (assuming no highway approach embankment, i.e. at an upstream cross section) is 1.2 ft/s. The floodplain flow is equal to 1,413 cfs for the left overbank and 2,825 cfs for the right overbank.

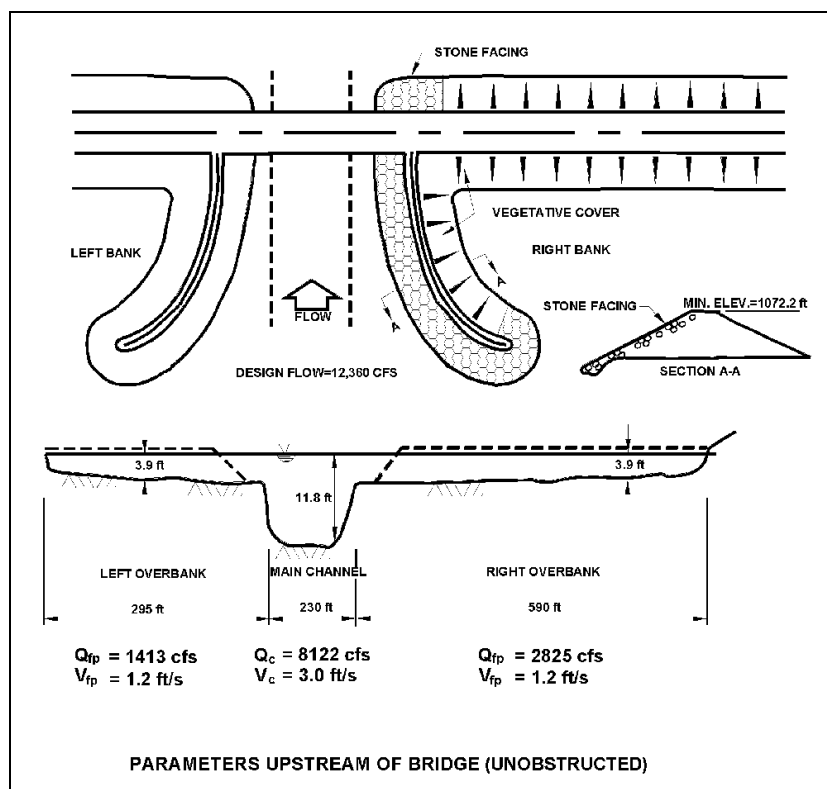

Figure 10.5. Example guide bank design (English).

Using the continuity equation and noting that the abutments are set back 148 ft from each bank, the flood plain discharge intercepted by each approach embankment is:

$$Q = AV$$

$$(Q_f)_{\text{right}} = 2,825 - (148)(3.9)(1.2) = 2132 \text{ cfs}$$

$$(Q_f)_{\text{left}} = 1,413 - (148)(3.9)(1.2) = 720 \text{ cfs}$$

Step 3. Determine Q_A and Q_f/Q_A for the Left and Right Overbank

The overbank discharge in the first 100 ft of opening adjacent to the left and right abutments needs to be determined next. Since for this case the flow is of uniform depth (3.9 ft) and velocity (1.2 ft/s) over the entire width of the floodplain, and both abutments are set back more than 100 ft from the main channel banks, the value of Q_A will be the same for both sides:

$$(Q_A)_{\text{right}} = (100)(3.9)(1.2) = 468 \text{ cfs}$$

$$(Q_A)_{\text{left}} = (100)(3.9)(1.2) = 468 \text{ cfs}$$

For the left and right overbanks the reference values of Q_f/Q_A can be determined by simple division of the discharges determined in previous steps:

$$\left(\frac{Q_f}{Q_A}\right)_{\text{right}} = \frac{2132}{468} = 4.5$$

$$\left(\frac{Q_f}{Q_A}\right)_{\text{left}} = \frac{720}{468} = 1.5$$

For design purposes, the largest value will result in the more conservative determination of the length of the guide banks, except where Step 4 indicates a guide bank is required for only one of the overbank areas.

Step 4. Determine the Length of the Guide Bank, L_s

The average channel velocity through the bridge opening can be determined by dividing the total discharge of the stream, Q , by the cross-sectional flow area at the bridge opening, A_{n2} , which in this case includes the main channel (2,714 ft²) plus 148 ft of the left and right overbank areas adjacent to the abutments at the bridge opening (1,154 ft²). Thus:

$$V_{n2} = \frac{Q}{a_{n2}} = \frac{12360}{(11.8)(230) + 2(3.9)(148)}$$

$$V_{n2} = 3.2 \text{ ft / s}$$

For Q_f/Q_A equal to 4.5 and an average channel velocity of 3.2 ft/s, the length of the guide bank is determined using the nomograph presented in Figure 10.3.

$$(L_s)_{\text{right}} = 138 \text{ ft}$$

For the left abutment, a Q_f/Q_A of 1.5 and V_{n2} of 3.2 ft/s indicate that L_s would be less than 50 ft. Thus, no guide bank is required for the left overbank for this example.

Step 5. Miscellaneous Specifications

The offset of the guidebank is determined to be 55.2 ft by multiplying L_s by 0.4. The offset and length determine the plan layout of the guide bank. Coordinates of points along the centerline can be determined using Equation 10.1, which is the equation of an ellipse with a major to minor axis ratio of 2.5:1. The coordinates for a 138 ft long guide bank with a 55.2 ft offset are presented in Table 10.2.

X (ft)	Y (ft)
0	55.2
30	53.9
60	49.7
90	41.8
120	27.3
138	0.0

These coordinates would be used for conceptual level design. For construction, coordinates at an offset or along the toe of side slope would be necessary.

The crest of the guide bank must be a minimum of 2 ft above the design water surface (elevation 1070.2 ft). Therefore, the crest elevation for this example should be greater than or equal to 1072.2 ft. The crest width should be at least 3 ft. For this example, a crest width of 10 ft will be specified so that the guide bank can be easily constructed with dump trucks.

Stone or rock riprap should be placed in the locations shown on Figure 10.4. This riprap should extend a minimum of 2 ft above the design water surface (elevation 1070.2 m) and below the intersection of the toe of the guide bank and the existing ground to the combined long-term degradation and contraction scour depth.

10.5 REFERENCES

1. Bradley, J.N., 1978, "Hydraulics of Bridge Waterways," Hydraulic Design Series No. 1 U.S. Department of Transportation, FHWA.
2. Karaki, S.S., 1959, "Hydraulic Model Study of Spur Dikes for Highway Bridge Openings," Colorado State University, Civil Engineering Section, Report CER59SSK36, September, 47 pp.
3. Karaki, S.S., 1961, "Laboratory Study of Spur Dikes for Highway Bridge Protection," Highway Research Board Bulletin 286, Washington, D.C., p. 31.
4. Neeley, B.L., Jr., 1966, "Hydraulic Performance of Bridges in the State of Mississippi," U.S. Geological Survey, Jackson, MS, June. (Unpublished report).
5. Brown, S.A. and E.S. Clyde, 1989, "Design of Riprap Revetment," Hydraulic Engineering Circular No. 11, FHWA-IP-89-016. Prepared for the Federal Highway Administration, Washington, D.C.

6. Richardson, E.V., D.B. Simons, and P.F. Lagasse, 2001, "River Engineering for Highway Encroachments - Highways in the River Environment," Report No. FHWA NHI-01-004, Hydraulic Design Series No. 6, Federal Highway Administration, Washington, D.C.
7. Arneson, L.A. and J.O. Shearman, 1987, "User's Manual for WSPRO - A Computer Model for Water Surface Profile Computations," Office of Technology Applications, Federal Highway Administration, FHWA Report No. FHWA-SA-98-080, June 1998.
8. U.S. Army Corps of Engineers, 1991, "Water Surface Profiles User's Manual," HEC-2, Hydrologic Engineering Center, Davis, CA.
9. U.S. Army Corps of Engineers, 1998, "HEC-RAS River Analysis System," User's Manual, Version 2.2, Hydrologic Engineering Center, Davis, CA.

(page intentionally left blank)

DESIGN GUIDELINE 11
CHECK DAMS/DROP STRUCTURES

(page intentionally left blank)

DESIGN GUIDELINE 11

CHECK DAMS/DROP STRUCTURES

11.1 BACKGROUND

Check dams or channel drop structures are used downstream of highway crossings to arrest head cutting and maintain a stable streambed elevation in the vicinity of the bridge. Check dams are usually built of rock riprap, concrete, sheet piles, gabions, or treated timber piles. The material used to construct the structure depends on the availability of materials, the height of drop required, and the width of the channel. Rock riprap and timber pile construction have been most successful on channels having small drops and widths less than 30 m (100 ft). Sheet piles, gabions, and concrete structures are generally used for larger drops on channels with widths ranging up to 100 m (300 ft). Check dam location with respect to the bridge depends on the hydraulics of the bridge reach and the amount of headcutting or degradation anticipated.

Check dams can initiate erosion of banks and the channel bed downstream of the structure as a result of energy dissipation and turbulence at the drop. This local scour can undermine the check dam and cause failure. The use of energy dissipators downstream of check dams can reduce the energy available to erode the channel bed and banks. **In some cases it may be better to construct several consecutive drops of shorter height to minimize erosion.** Concrete lined basins as discussed later may also be used.

Lateral erosion of channel banks just downstream of drop structures is another adverse result of check dams and is caused by turbulence produced by energy dissipation at the drop, bank slumping from local channel bed erosion, or eddy action at the banks. Bank erosion downstream of check dams can lead to erosion of bridge approach embankments and abutment foundations if lateral bank erosion causes the formation of flow channels around the ends of check dams. The usual solution to these problems is to place riprap revetment on the streambank adjacent to the check dam. The design of riprap is given in HDS 6,⁽¹⁾ HEC-11,⁽²⁾ and USACE⁽³⁾ (see also Design Guideline 12).

Erosion of the streambed can also be reduced by placing rock riprap in a preformed scour hole downstream of the drop structure. A row of sheet piling with top set at or below streambed elevation can keep the riprap from moving downstream. Because of the problems associated with check dams, the design of these countermeasures requires designing the check dams to resist scour by providing for dissipation of excess energy and protection of areas of the bed and the bank which are susceptible to erosive forces.

11.2 BED SCOUR FOR VERTICAL DROP STRUCTURES

11.2.1 Estimating Bed Scour

The most conservative estimate of scour downstream of channel drop structures is for vertical drops with unsubmerged flow conditions. For the purposes of design the maximum expected scour can be assumed to be equal to the scour for a vertical, unsubmerged drop, regardless of whether the drop is actually sloped or is submerged.

A sketch of a typical vertical drop structure with a free overfall is shown in Figure 11.1. An equation developed by the Bureau of Reclamation (USBR) is recommended to estimate the depth of scour downstream of a vertical drop:

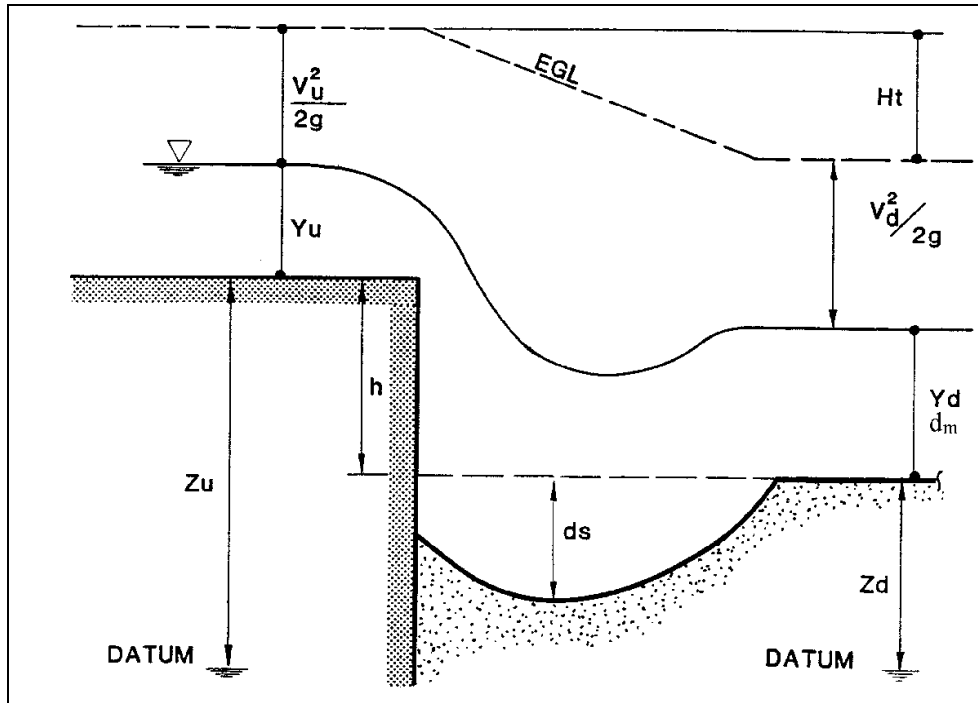

Figure 11.1. Schematic of a vertical drop caused by a check dam.

$$d_s = K_u H_t^{0.225} q^{0.54} - d_m \quad (11.1)$$

where:

- d_s = local scour depth for a free overfall, measured from the streambed downstream of the drop, m (ft)
- q = discharge per unit width, $m^3/s/m$ (cfs/ft)
- H_t = total drop in head, measured from the upstream to the downstream energy grade line, m (ft)
- d_m, Y_d = tailwater depth, m (ft)
- K_u = 1.90 (SI)
- K_u = 1.32 (English)

It should be noted that H_t is the difference in the total head from upstream to downstream. This can be computed using the energy equation for steady uniform flow:

$$H_t = \left(Y_u + \frac{V_u^2}{2g} + Z_u \right) - \left(Y_d + \frac{V_d^2}{2g} + Z_d \right) \quad (11.2)$$

where:

Y	=	depth, m (ft)
V	=	velocity, m/s (ft/s)
Z	=	bed elevation referenced to a common datum, m (ft)
g	=	acceleration due to gravity 9.81 m/s ² (32.2 ft/s ²)

The subscripts *u* and *d* refer to up- and downstream of the channel drop, respectively.

The depth of scour as estimated by the above equation is independent of the grain size of the bed material. This concept acknowledges that the bed will scour regardless of the type of material composing the bed, but the rate of scour depends on the composition of the bed. In some cases, with large or resistant material, it may take years or decades to develop the maximum scour hole. In these cases, the design life of the bridge may need to be considered when designing the check dam.

The check dam must be designed structurally to withstand the forces of water and soil assuming that the scour hole is as deep as estimated using the equation above. Therefore, the designer should consult geotechnical and structural engineers so that the drop structure will be stable under the full scour condition. In some cases, a series of drops may be employed to minimize drop height and construction costs of foundations. Riprap or energy dissipation could be provided to limit depth of scour (see, for example, Peterka⁽⁵⁾ and HEC-14⁽⁶⁾).

11.2.2 Check Dam Design Example (SI)

The following design example is based upon a comparison of scour equations presented by the USBR.⁽⁴⁾

Given:

Channel degradation is threatening bridge foundations. Increasing the bed elevation 1.4 m will stabilize the channel at the original bed level. A drop structure will raise the channel bed and reduce upstream channel slopes, resulting in greater flow depths and reduced velocity upstream of the structure. For this example, as illustrated by Figure 11.2, the following hydraulic parameters are used:

Design Discharge	Q	= 167 m ³ /s
Channel Width	B	= 32 m
Upstream Water Depth	Y _u	= 3.22 m
Tail Water Depth	d _m , Y _d	= 2.9 m
Unit Discharge	q	= 5.22 m ³ /s/m
Upstream Mean Velocity	V _u	= 1.62 m/s
Downstream Mean Velocity	V _d	= 1.80 m/s
Drop Height	h	= 1.4 m

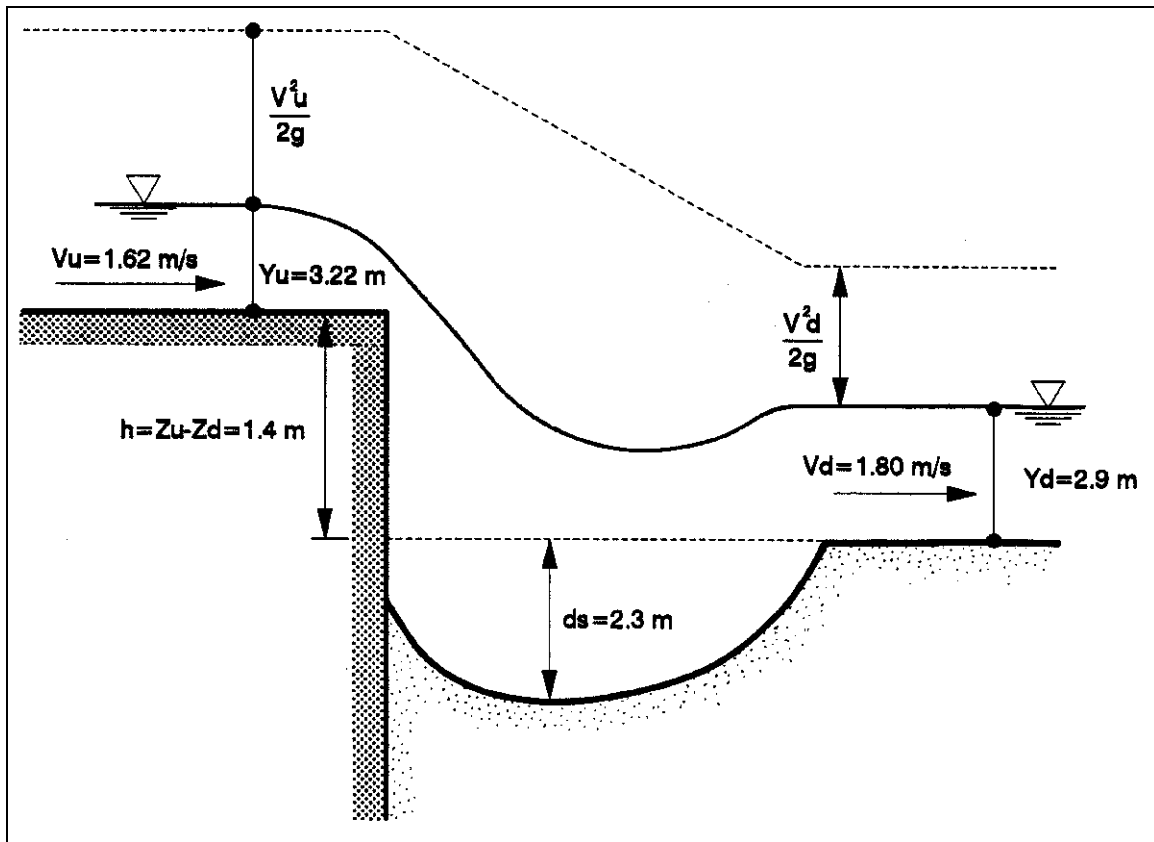

Figure 11.2. Design example of scour downstream of a drop structure.

H_t is calculated from the energy equation. Using the downstream bed as the elevation datum gives:

$$H_t = \left(3.22 + \frac{(1.62)^2}{(2)9.81} + 14 \right) - \left(2.9 + \frac{(1.80)^2}{(2)9.81} + 0 \right) = 16.9 \text{ m} \quad (11.3)$$

Using Equation (11.1), the estimated depth of scour below the downstream bed level is:

$$d_s = K_u H_t^{0.225} q^{0.54} - d_m$$

$$d_s = 1.90 (16.9)^{0.225} (5.22)^{0.54} - 2.9$$

$$d_s = 2.3 \text{ m}$$

In this case, the unsupported height of the structure is $(h + d_s)$ or 3.7 m. If, for structural reasons, this height is unacceptable, then either riprap to limit scour depth or a series of check dams could be constructed. It should be noted that if a series of drops are required, adequate distance between each drop must be maintained.⁽⁵⁾

11.2.3 Check Dam Design Example (English)

The following design example is based upon a comparison of scour equations presented by the USBR.⁽⁴⁾

Given:

Channel degradation is threatening bridge foundations. Increasing the bed elevation 4.6 ft will stabilize the channel at the original bed level. A drop structure will raise the channel bed and reduce upstream channel slopes, resulting in greater flow depths and reduced velocity upstream of the structure. For this example, as illustrated by Figure 11.3, the following hydraulic parameters are used:

Design Discharge	Q	= 5,900 ft ³ /s
Channel Width	B	= 105 ft
Upstream Water Depth	Y _u	= 10.6 ft
Tail Water Depth	d _m , Y _d	= 9.5 ft
Unit Discharge	q	= 56.2 ft ³ /s/ft
Upstream Mean Velocity	V _u	= 5.3 ft/s
Downstream Mean Velocity	V _d	= 5.9 ft/s
Drop Height	h	= 4.6 ft

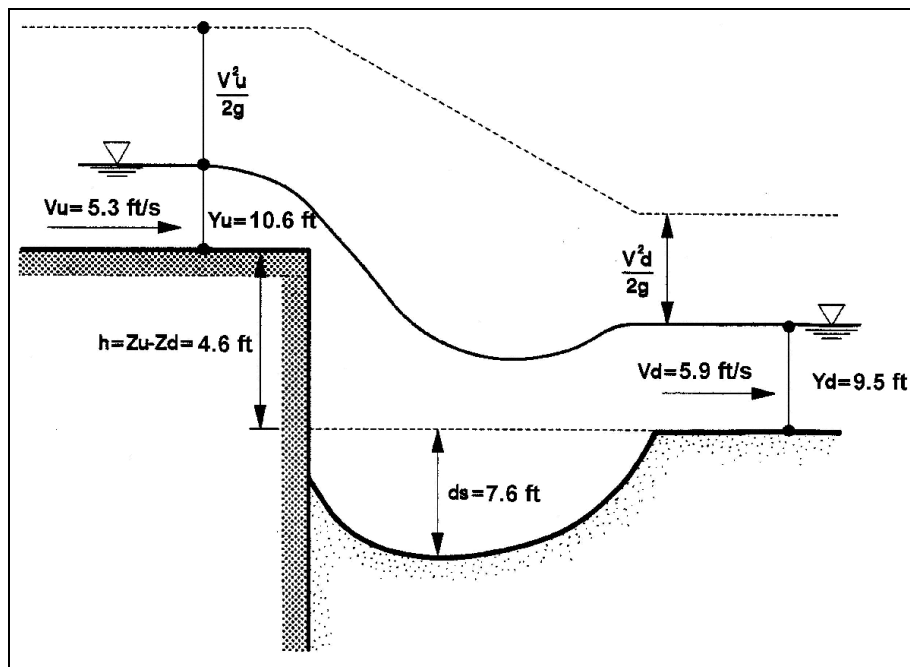

Figure 11.3. Design example of scour downstream of a drop structure.

H_t is calculated from the energy equation. Using the downstream bed as the elevation datum gives:

$$H_t = \left(10.6 + \frac{(5.3)^2}{(2)32.2} + 4.6 \right) - \left(9.5 + \frac{5.9^2}{(2)32.2} + 0 \right) = 5.6 \text{ ft} \quad (11.3)$$

Using Equation (11.1), the estimated depth of scour below the downstream bed level is:

$$d_s = K_u H_t^{0.225} q^{0.54} - d_m$$

$$d_s = 1.32 (5.6)^{0.225} (56.2)^{0.54} - 9.5$$

$$d_s = 7.6 \text{ ft}$$

In this case, the unsupported height of the structure is $(h + d_s)$ or 12.2 ft. If, for structural reasons, this height is unacceptable, then either riprap to limit scour depth or a series of check dams could be constructed. It should be noted that if a series of drops are required, adequate distance between each drop must be maintained.⁽⁵⁾

11.2.4 Lateral Scour Downstream of Check Dams

As was mentioned, lateral scour of the banks of a stream downstream of check dams can cause the streamflow to divert around the check dam. If this occurs, a head cut may move upstream and endanger the highway crossing. To prevent this the banks of the stream must be adequately protected using riprap or other revetments. Riprap should be sized and placed in a similar fashion as for spurs and guide banks. The designer is referred to HDS 6 or HEC-11 for proper sizing, and placement of riprap on the banks.^(1,2) Revetments are discussed in Design Guideline 12.

11.3 STILLING BASINS FOR DROP STRUCTURES

This section on stilling basins for drop structures is taken from the FHWA Hydraulic Engineering Circular Number 14, "Hydraulic Design of Energy Dissipators for Culverts and Channels."⁽⁶⁾

A general design for a stilling basin at the toe of a drop structure was developed by the St. Anthony Falls Hydraulic Laboratory, University of Minnesota.⁽⁷⁾ The basin consists of a horizontal apron with blocks and sills to dissipate energy. Tailwater also influences the amount of energy dissipated. The stilling basin length computed for the minimum tailwater level required for good performance may be inadequate at high tailwater levels. Dangerous scour of the downstream channel may occur if the nappe is supported sufficiently by high tailwater so that it lands beyond the end of the stilling basin. A method for computing the stilling basin length for all tailwater levels is presented.

The design is applicable to relative heights of fall ranging from $1.0(h_o/y_c)$ to $15(h_o/y_c)$ and to crest lengths greater than $1.5y_c$. Here h_o is the vertical distance between the crest and the stilling basin floor, and y_c is the critical depth of flow at the crest (Figure 11.4). The straight drop structure is effective if the drop does not exceed 4.6 m (15 ft) and if there is sufficient tailwater.

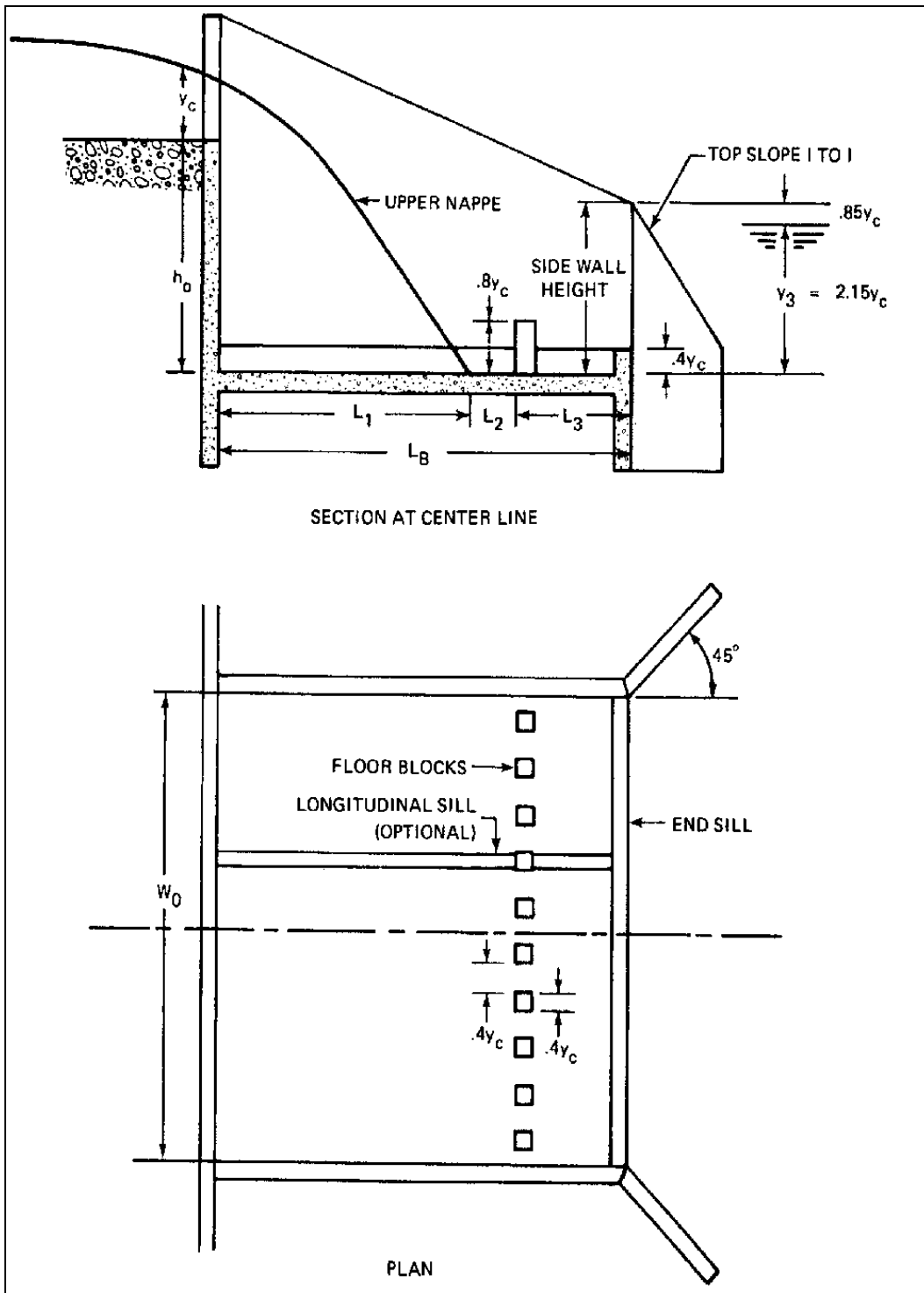

Figure 11.4. Straight drop structure stilling basin.

There are several elements which must be considered in the design of this stilling basin. These include the length of basin, the position and size of floor blocks, the position and height of end sill, the position of the wingwalls, and the approach channel geometry. Figure 11.4 illustrates a straight drop structure which provides protection from scour in the downstream channel.

11.3.1 Design Procedures

1. Calculate the specific head in approach channel.

$$H = y_0 + \frac{V_0^2}{2g} \quad (11.4)$$

where:

$$\begin{aligned} y_0 &= \text{normal depth in the approach channel} \\ V_0 &= \text{velocity associated with normal depth in the approach channel} \end{aligned}$$

2. Calculate critical depth.

$$y_c = \frac{2}{3}H \quad (11.5)$$

3. Calculate the minimum height for tailwater surface above the floor of the basin.

$$y_3 = 2.15 y_c \quad (11.6)$$

4. Calculate the vertical distance of tailwater below the crest. This will generally be a negative value since the crest is used as a reference point.

$$h_2 = -(h - y_0) \quad (11.7)$$

where:

$$\begin{aligned} \text{"h"} &= \text{total drop from the crest of the drop to the flow line of the outlet channel} \\ &\text{and } y_0 \text{ is the normal depth in the outlet channel} \end{aligned}$$

5. Determine the location of the stilling basin floor relative to the crest.

$$h_o = h_2 - y_3 \quad (11.8)$$

6. Determine the minimum length of the stilling basin, L_B , using:

$$L_B = L_1 + L_2 + L_3 = L_1 + 2.25 y_c \quad (11.9)$$

where:

L_1 is the distance from the headwall to the point where the surface of the upper nappe strikes the stilling basin floor. This is given by:

$$L_1 = (L_f + L_s) / 2 \quad (11.10)$$

where:

$$L_f = y_c \left\{ -0.406 + \sqrt{3.195 - \frac{4.368 h_0}{y_c}} \right\} \quad (11.11)$$

$$L_t = \left\{ -0.406 + \sqrt{3.195 - \frac{4.368 h_2}{y_c}} \right\} y_c \quad (11.12)$$

$$L_s = \frac{\left[0.691 + 0.228 \left(\frac{L_t}{y_c} \right)^2 - \left(\frac{h_0}{y_c} \right) \right] y_c}{\left[0.185 + 0.456 \left(\frac{L_t}{y_c} \right) \right]} \quad (11.13)$$

or L_1 can be found graphically from Figure 11.5

L_2 is the distance from the point at which the surface of the upper nappe strikes the stilling basin floor to the upstream face of the floor blocks, Figure 11.4. This distance can be determined by:

$$L_2 = 0.8 (y_c) \quad (11.14)$$

L_3 is the distance between the upstream face of the floor blocks and the end of the stilling basin. This distance can be determined from:

$$L_3 > 1.75 y_c \quad (11.15)$$

7. Proportion the floor blocks as follows:

- a. Height is $0.8 y_c$,
- b. Width and spacing should be $0.4 y_c$, with a variation of $\pm 0.15 y_c$, permitted,
- c. Blocks should be square in plan, and
- d. Blocks should occupy between 50 percent and 60 percent of the stilling basin width.

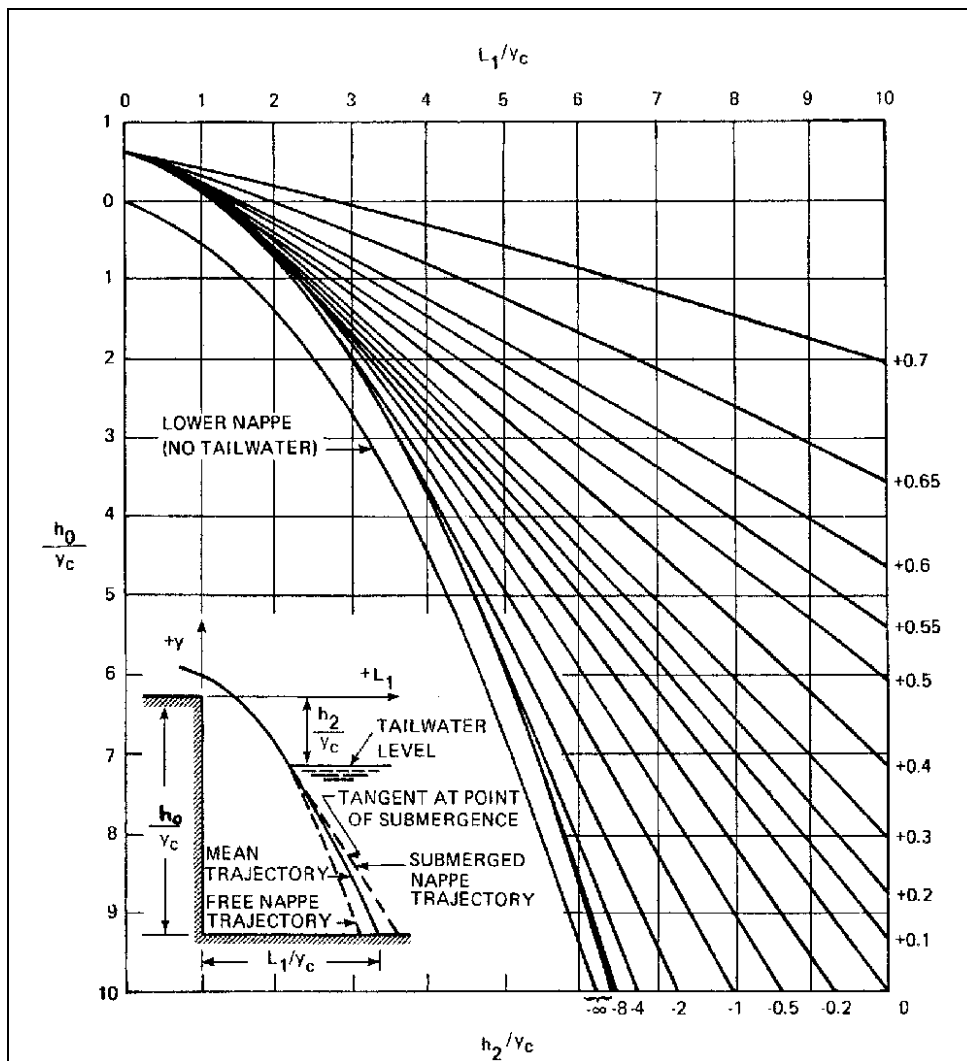

Figure 11.5. Design chart for determination of L_1 .

8. Calculate the end sill height, $(0.4 y_c)$.
9. Longitudinal sills, if used, should pass through, not between, the floor blocks. These sills are for structural purposes and are neither beneficial nor harmful hydraulically.
10. Calculate the sidewall height above the tailwater level, $(0.85 y_c)$.
11. Wingwalls should be located at an angle of 45° with the outlet centerline and have a top slope of 1 to 1.

12. Modify the approach channel as follows:

- a. Crest of spillway should be at same elevation as approach channel,
- b. Bottom width should be equal to the spillway notch length, W_o at the headwall, and
- c. Protect with riprap or paving for a distance upstream from the headwall equal to three times the critical depth, y_c ,

13. No special provision of aeration of the space beneath the nappe is required if the approach channel geometry is as recommended in step 12.

The geometry of the undisturbed flow should be taken into consideration in the design of a straight drop stilling basin. If the overfall crest length is less than the width of the approach channel, it is important that a transition be properly designed by shaping the approach channel to reduce the effect of end contractions. Otherwise the contraction at the ends of the spillway notch may be so pronounced that the jet will land beyond the stilling-basin and the concentration of high velocities at the center of the outlet may cause additional scour in the downstream channel.

11.3.2 Stilling Basin Design Example (SI)

Using the same problem as was used to estimate scour at the check dam (Section 11.2.2), establish the size of a stilling basin.

Given:

Channel degradation is threatening bridge foundations. Increasing the bed elevation 1.4 m will stabilize the channel at the original bed level. A drop structure will raise the channel bed and reduce upstream channel slopes, resulting in greater flow depths and reduced velocity upstream of the structure. For this example, as illustrated by Figure 11.2, the following hydraulic parameters are used:

Design Discharge	Q	= 167 m ³ /s
Channel Width	B	= 32 m
Upstream Water Depth	Y_u	= 3.22 m
Tail Water Depth	d_m, Y_d	= 2.9 m
Unit Discharge	q	= 5.22 m ³ /s
Upstream Mean Velocity	V_u	= 1.62 m/s
Downstream Mean Velocity	V_d	= 1.80 m/s
Drop Height	h	= 1.4 m

Find: Dimensions for the stilling basin as shown in Figure 11.4.

Solution:

Step 1. Calculate the Specific Head in Approach Channel

$$H = y_0 + \frac{V_0^2}{2g} = 3.22 + \frac{(1.62)^2}{2(9.81)} = 3.35 \text{ m}$$

Step 2. Calculate Critical Depth

$$y_c = \frac{2}{3} H = \frac{2}{3}(3.35) = 2.23 \text{ m}$$

Step 3. Calculate the Minimum Height for Tailwater Surface Above the Floor of the Basin

$$y_3 = 2.15 y_c = 2.15(2.23) = 4.8 \text{ m}$$

Step 4. Calculate the Vertical Distance of Tailwater Below the Crest

This will generally be a negative value since the crest is used as a reference point.

$$h_2 = -(h - y_0) = -(1.4 - 2.9) = +1.5 \text{ m}$$

where:

"h" = total drop from the crest of the drop to the flow line of the outlet channel and y_0 is the normal depth in the outlet channel

Step 5. Determine the Location of the Stilling Basin Floor Relative to the Crest

$$h_0 = h_2 - y_3 = 1.5 - 4.8 = -3.3 \text{ m}$$

Step 6. Determine the Minimum Length of the Stilling Basin

$$L_B = L_1 + L_2 + L_3 = L_1 + 2.55 y_c$$

where:

L_1 is the distance from the headwall to the point where the surface of the upper nappe strikes the stilling basin floor. This is given by:

$$L_1 = (L_f + L_s) / 2$$

where:

$$L_f = y_c \left\{ -0.406 + \sqrt{3.195 - \frac{4.368h_0}{y_c}} \right\} = 2.23 \left\{ -0.406 + \sqrt{3.195 - \frac{4.368(-3.3)}{2.23}} \right\}$$

$$L_f = 6.02 \text{ m}$$

$$L_t = \left\{ -0.406 + \sqrt{3.195 - \frac{4.368h_2}{y_c}} \right\} y_c = \left\{ -0.406 + \sqrt{3.195 - \frac{4.368(1.5)}{2.23}} \right\} 2.23$$

$$L_t = 0.25 \text{ m}$$

$$L_s = \frac{\left[0.691 + 0.228 \left(\frac{L_t}{y_c} \right)^2 - \left(\frac{h_0}{y_c} \right) \right] y_c}{\left[0.185 + 0.456 \left(\frac{L_t}{y_c} \right) \right]} = \frac{\left[0.691 + 0.228 \left(\frac{0.25}{2.23} \right)^2 - \left(\frac{-3.3}{2.23} \right) \right] 2.23}{\left[0.185 + 0.456 \left(\frac{0.25}{2.23} \right) \right]}$$

$$L_s = 20.53 \text{ m}$$

$$\text{Then, } L_1 = (6.02 + 20.53) / 2 = 13.38 \text{ m}$$

or L_1 can be found graphically from Figure 11.5

L_2 is the distance from the point at which the surface of the upper nappe strikes the stilling basin floor to the upstream face of the floor blocks, Figure 11.4. This distance can be determined by:

$$L_2 = 0.8 (y_c) = 0.8 (2.23) = 1.78 \text{ m}$$

L_3 is the distance between the upstream face of the floor blocks and the end of the stilling basin. This distance can be determined from:

$$L_3 > 1.75 y_c = 1.75 (2.23) = 3.90 \text{ m}$$

Step 7. Proportion the Floor Blocks

- Height is $0.8 y_c$, $0.8 (2.23) = 1.78 \text{ m}$
- Width and spacing should be $0.4 y_c$, with a variation of $\pm 0.15 y_c$, permitted,
- Blocks should be square in plan, and
- Blocks should occupy between 50 percent and 60 percent of the stilling basin width.

Step 8. Calculate the End Sill Height

$$(0.4 y_c) = 0.4 (2.23) = 0.89 \text{ m}$$

Step 9. Longitudinal Sills

If used, should pass through, not between, the floor blocks. These sills are for structural purposes and are neither beneficial nor harmful hydraulically.

Step 10. Calculate the Sidewall Height Above the Tailwater Level

$(0.85 y_c) = 0.85 (2.23) = 1.78 \text{ m}$

Step 11. Wingwalls

Should be located at an angle of 45° with the outlet centerline and have a top slope of 1 to 1.

Step 12. Modify the Approach Channel

- a. crest of spillway should be at same elevation as approach channel,
- b. bottom width should be equal to the spillway notch length, W_o at the headwall, and
- c. protect with riprap or paving for a distance upstream from the headwall equal to three times the critical depth, y_c ,

Step 13. Aeration of the Nappe

No special provision of aeration of the space beneath the nappe is required if the approach channel geometry is as recommended in Step 12.

11.3.3 Stilling Basin Design Example (English)

Using the same problem as was used to estimate scour at the check dam (Section 11.2.3), establish the size of a stilling basin.

Given:

Channel degradation is threatening bridge foundations. Increasing the bed elevation 4.6 ft will stabilize the channel at the original bed level. A drop structure will raise the channel bed and reduce upstream channel slopes, resulting in greater flow depths and reduced velocity upstream of the structure. For this example, as illustrated by Figure 11.3, the following hydraulic parameters are used:

Design Discharge	Q	= 5,900 ft ³ /s
Channel Width	B	= 105 ft
Upstream Water Depth	Y _u	= 10.6 ft
Tail Water Depth	d _m , Y _d	= 9.5 ft
Unit Discharge	q	= 56.2 ft ³ /s/ft
Upstream Mean Velocity	V _u	= 5.3 ft/s
Downstream Mean Velocity	V _d	= 5.9 ft/s
Drop Height	h	= 4.6 ft

Find: Dimensions for the stilling basin as shown in Figure 11.4.

Solution:

Step 1. Calculate the Specific Head in Approach Channel

$$H = y_0 + \frac{V_0^2}{2g} = 10.6 + \frac{(53)^2}{2(32.2)} = 11.0 \text{ ft}$$

Step 2. Calculate Critical Depth

$$y_c = \frac{2}{3} H = \frac{2}{3}(11.0) = 7.3 \text{ ft}$$

Step 3. Calculate the Minimum Height for Tailwater Surface Above the Floor of the Basin

$$y_3 = 2.15 y_c = 2.15 (7.3) = 15.7 \text{ ft}$$

Step 4. Calculate the Vertical Distance of Tailwater Below the Crest

This will generally be a negative value since the crest is used as a reference point.

$$h_2 = -(h - y_0) = -(4.6 - 9.5) = +4.9 \text{ ft}$$

where:

"h" = total drop from the crest of the drop to the flow line of the outlet channel
and y_0 is the normal depth in the outlet channel

Step 5. Determine the Location of the Stilling Basin Floor Relative to the Crest

$$h_o = h_2 - y_3 = 4.9 - 15.7 = -10.8 \text{ ft}$$

Step 6. Determine the Minimum Length of the Stilling Basin

$$L_B = L_1 + L_2 + L_3 = L_1 + 2.55 y_c$$

where:

L_1 is the distance from the headwall to the point where the surface of the upper nappe strikes the stilling basin floor. This is given by:

$$L_1 = (L_f + L_s) / 2$$

where:

$$L_f = y_c \left\{ -0.406 + \sqrt{3.195 - \frac{4.368h_0}{y_c}} \right\} = 7.3 \left\{ -0.406 + \sqrt{3.195 - \frac{4.368(-10.8)}{7.3}} \right\}$$

$$L_f = 19.7 \text{ ft}$$

$$L_s = \frac{\left[0.691 + 0.228 \left(\frac{L_t}{y_c} \right)^2 - \left(\frac{h_0}{y_c} \right) \right] y_c}{\left[0.185 + 0.456 \left(\frac{L_t}{y_c} \right) \right]} = \frac{\left[0.691 + 0.228 \left(\frac{0.78}{7.3} \right)^2 - \left(\frac{-10.8}{7.3} \right) \right] 7.3}{\left[0.185 + 0.456 \left(\frac{0.78}{7.3} \right) \right]}$$

$$L_t = \left\{ -0.406 + \sqrt{3.195 - \frac{4.368h_2}{y_c}} \right\} y_c = \left\{ -0.406 + \sqrt{3.195 - \frac{4.368(4.9)}{7.3}} \right\} 7.3$$

$$L_t = 0.78 \text{ ft}$$

$$L_s = 67.9 \text{ ft}$$

$$\text{Then, } L_1 = (19.7 + 67.9) / 2 = 43.8 \text{ ft}$$

or L_1 can be found graphically from Figure 11.5

L_2 is the distance from the point at which the surface of the upper nappe strikes the stilling basin floor to the upstream face of the floor blocks, Figure 11.4. This distance can be determined by:

$$L_2 = 0.8 (y_c) = 0.8 (7.3) - 5.8 \text{ ft}$$

L_3 is the distance between the upstream face of the floor blocks and the end of the stilling basin. This distance can be determined from:

$$L_3 > 1.75 y_c = 1.75 (7.3) = 12.8 \text{ ft}$$

Step 7. Proportion the Floor Blocks

- Height is $0.8 y_c$, $0.8 (7.3) - 5.8 \text{ ft}$
- Width and spacing should be $0.4 y_c$, with a variation of $\pm 0.15 y_c$, permitted,
- Blocks should be square in plan, and
- Blocks should occupy between 50 percent and 60 percent of the stilling basin width.

Step 8. Calculate the End Sill Height

$$(0.4 y_c) = 0.4 (7.3) = 2.9 \text{ ft}$$

Step 9. Longitudinal Sills

If used, should pass through, not between, the floor blocks. These sills are for structural purposes and are neither beneficial nor harmful hydraulically.

Step 10. Calculate the Sidewall Height Above the Tailwater Level

$$(0.85 y_c) = 0.85 (7.3) = 6.2 \text{ ft}$$

Step 11. Wingwalls

Should be located at an angle of 45° with the outlet centerline and have a top slope of 1 to 1.

Step 12. Modify the Approach Channel

- a. crest of spillway should be at same elevation as approach channel,
- b. bottom width should be equal to the spillway notch length, W_o at the headwall, and
- c. protect with riprap or paving for a distance upstream from the headwall equal to three times the critical depth, y_c ,

Step 13. Aeration of the Nappe

No special provision of aeration of the space beneath the nappe is required if the approach channel geometry is as recommended in Step 12.

11.4 REFERENCES

1. Richardson, E.V., D.B. Simons, and P.F. Lagasse, 2001, "River Engineering for Highway Encroachments - Highways in the River Environment," Report FHWA NHI 01-004, Hydraulics Design Series No. 6, Federal Highway Administration, Washington, D.C.
2. Brown, S.A. and E.S. Clyde, 1989, "Design of Riprap Revetment," Hydraulic Engineering Circular No.11, FHWA-IP-89-016. Prepared for the Federal Highway Administration, Washington, D.C.
3. U.S. Army Corps of Engineers, 1981, "The Streambank Erosion Control Evaluation and Demonstration Act of 1974," Final Report to Congress, Executive Summary and Conclusions.
4. Pemberton, E.L. and J.M. Lara, 1984, "Computing Degradation and Local Scour," Technical Guidelines for Bureau of Reclamation, Engineering Research Center, Denver, CO, January.
5. Peterka, A.J., 1964, "Hydraulic Design of Stilling Basins and Energy Dissipators," Engineering Monograph No. 25, Bureau of Reclamation, Division of Research, Denver, CO.
6. Federal Highway Administration, 1983, "Hydraulic Design of Energy Dissipators for Culverts and Channels," Hydraulic Engineering Circular Number 14, U.S. Department of Transportation, Washington, D.C.
7. Donnelly, Charles A., and Fred W. Blaisdell, 1954, "Straight Drop Spillway Stilling Basin," University of Minnesota, St. Anthony Falls Hydraulic Laboratory, Technical Paper 15, Series B, November

(page intentionally left blank)

DESIGN GUIDELINE 12
REVETMENTS

(page intentionally left blank)

DESIGN GUIDELINE 12

REVETMENTS

12.1 INTRODUCTION

Revetments are used to provide protection for embankments, streambanks, and streambeds. They may be flexible or rigid and can be used to counter all erosion mechanisms. They do not significantly constrict channels or alter flow patterns. Revetments do not provide resistance against slumping in saturated streambanks and embankments, and are relatively unsuccessful in stabilizing streambanks and streambeds in degrading streams. Special precautions must be observed in the design of revetments for degrading channels.

12.2 FLEXIBLE REVETMENTS

Flexible revetments include rock riprap, rock-and-wire mattresses, gabions, precast concrete blocks, rock-fill trenches, windrow revetments, used tire revetments, and vegetation. Rock riprap adjusts to distortions and local displacement of materials without complete failure of the revetment installation. However, flexible rock-and-wire mattress and gabions may sometimes span the displacement of underlying materials, but usually can adjust to most local distortions. Used tire mattresses and precast concrete block mattresses are generally stiffer than rock riprap and gabions and, therefore, do not adjust well to local displacement of underlying materials. References for design guidelines of flexible revetments depend on the type of flexible revetment being used and are discussed separately in the following sections.

12.2.1 Rock Riprap, Rock-and Wire Mattress, Gabions, and Precast Concrete Blocks

Design guidelines, design procedures, and suggested specifications for rock riprap, wire enclosed rock, stacked block gabions, and precast concrete blocks are included in HEC-11.⁽¹⁾ Design Guideline 4 provides design procedures for articulated concrete block systems for both revetment applications and pier scour protection.

Since rock riprap is commonly used as a countermeasure for stream bank erosion, a short discussion of the types of rock riprap and a design procedure as discussed in HEC-11⁽¹⁾ follows (also see Chapter 4, Section 4.4).

Riprap as discussed in this section is defined as a flexible channel or bank lining consisting of a well-graded mixture of angular rock usually dumped in place. Other types of riprap are “hand-placed” and “keyed or plated” riprap. Hand-placed riprap is carefully placed by hand or by a mechanized manner in a definite pattern with voids between the large stone being filled with smaller rock. Plated riprap is placed on the bank with a skip and tamped into place using a heavy steel plate leaving a smoother surface than dumped riprap. See HEC-11⁽¹⁾ for more information on each of these types.

Dumped riprap does not mean end dumping from trucks and allowing the material to roll down the slope which can cause size segregation. It means that the riprap is placed in a manner to prevent segregation by using a crane with a bucket or dragline. Regardless of how it is placed, care should be taken to prevent segregation of the rock mixture. Dumped riprap should form a layer of loose stone where individual stones may move independently to

adjust to the movement of the bank material being protected. This minor movement may occur without complete failure of the installation. This movement allows the riprap to be somewhat "self healing" and is one of the main advantages of dumped rock riprap.

12.2.2 Design Guidelines

HEC-11⁽¹⁾ provides design guidance for sizing the rock for dumped riprap used for bank protection. The procedure is based on the tractive force theory but has velocity as its primary design parameter. The equation is based on the assumption of uniform or gradually varying flow. A stability factor is used to correct the equation for bends and turbulent mixing at rapidly varying flow conditions.

The stone size is established by this equation:

$$D_{50} = \frac{K_u C V_a^3}{d_{avg}^{0.5} K_1^{1.5}} \quad (12.1)$$

where:

- D_{50} = median particle size, m (ft)
- C = correction for specific gravity and stability factor
- V_a = average velocity in the main channel, m/s (fps)
- d_{avg} = average flow depth in the main flow channel, m (ft)
- K_1 = bank angle correction factor as given below
- K_u = 0.0059 SI
- K_u = 0.001 English

$$K_1 = \left[1 - \frac{\sin^2 \theta}{\sin^2 \phi} \right]^{0.5} \quad (12.2)$$

where:

- θ = bank angle with the horizontal
- ϕ = riprap material's angle of repose as given in Figure 12.1

The average flow depth and velocity used in Equation 12.1 are main channel values where the main channel is defined as the area between the channel banks.

The correction for the specific gravity and the stability factor is defined by the following equation:

$$C = \frac{1.61(SF)^{1.5}}{(S_s - 1)^{1.5}} \quad (12.3)$$

where:

- S_s = specific gravity of the rock riprap
- SF = stability factor as described below

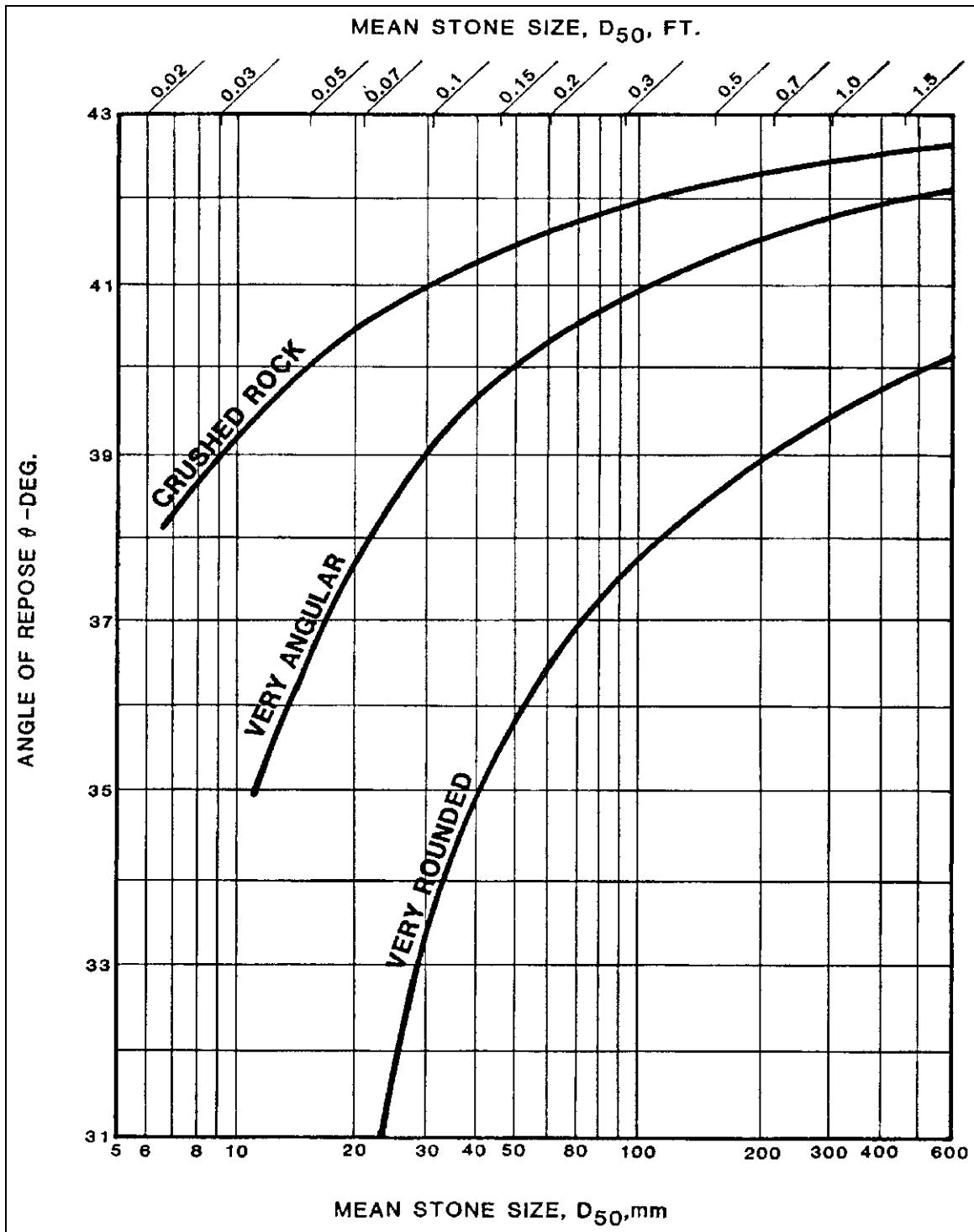

Figure 12.1. Angle of repose of riprap in terms of mean size and shape of stone.⁽²⁾

The stability factor (SF) is defined as the ratio of the riprap material critical shear stress and average tractive force exerted by the flow field. As long as the SF is greater than 1, the critical shear stress of the material is greater than the flow induced tractive stress, and the riprap is considered stable. A SF of 1.2 was used in the development of Equation 12.1.

The SF may be used to reflect the level of uncertainty in the conditions at the site due to discharge estimation inaccuracies, debris, ice impacts, etc. Suggested values for the SF are:

<u>Condition</u>	<u>SF Range</u>
<u>Uniform flow conditions:</u> Straight or mildly curving reach (curve radius/channel width >30); impact from wave action and floating debris is minimal; little or no uncertainty in design parameters.	1.0 - 1.2
<u>Gradually varying flow:</u> Moderate bend curvature (30 > curve radius/channel width >10); impact from waves or floating debris moderate.	1.3 - 1.6
<u>Approaching rapidly varying flow:</u> Sharp bend curvature (10 > curve radius/channel width); significant impact potential from floating debris and/or ice; significant wind and/or boat generated waves (0.30 -0.61 m (1 - 2 ft)); high flow turbulence; turbulent mixing at bridge abutments; significant uncertainty in design parameters.	1.6 - 2.0

12.2.3 Thickness of Riprap

All stones should be contained reasonably well within the riprap layer thickness. The following criteria are given in HEC-11.⁽¹⁾

- It should not be less than the spherical diameter of the D_{100} stone or less than 1.5 times the spherical diameter of the D_{50} stone, whichever results in the greater thickness.
- It should not be less than 0.30 m (1 ft) for practical placement.
- The thickness determined by either 1 or 2 should be increased by 50 percent when the riprap is placed underwater to compensate for uncertainties associated with this placement.
- An increase in layer thickness of 0.15 to 0.30 m (0.5 to 1 ft), accompanied by an increase in stone sizes, should be made where the riprap will be subject to attack by floating debris, ice, or by waves from boat wakes, wind, or bedforms.

12.2.4 Gradation of Riprap

The gradation of stones in riprap revetment affects the riprap's resistance to erosion. The stone should be reasonably well graded throughout the riprap layer thickness. Specifications should provide for two limiting gradation curves, and the stone gradation (as determined from a field test sample) should lay within these limits. The gradation limits should not be so restrictive that production costs would be excessive. HEC-11⁽¹⁾ presents suggested guidelines for establishing gradation limits (see Table 12.1). Tables 12.1 and 12.3 present six suggested gradation classes based on AASHTO specifications.⁽³⁾

Stone Size Range m (ft)	Stone Weight Range kg (lb)	Percent of Gradation Smaller Than
1.5 D ₅₀ to 1.7 D ₅₀	3.0 W ₅₀ to 5.0 W ₅₀	100
1.2 D ₅₀ to 1.4 D ₅₀	2.0 W ₅₀ to 2.75 W ₅₀	85
1.0 D ₅₀ to 1.15 D ₅₀	1.0 W ₅₀ to 1.5 W ₅₀	50
0.4 D ₅₀ to 0.6 D ₅₀	0.1 W ₅₀ to 0.2 W ₅₀	15

Riprap Class	Rock Size ¹ (m)	Rock Size ² (kg)	Percent of Riprap Smaller Than
Facing	0.395	85	100
	0.294	35	50
	0.122	2.5	10
Light	0.546	225	100
	0.395	85	50
	0.122	2.5	10
0.23 Metric Ton	0.688	450	100
	0.546	225	50
	0.294	35	10
0.45 Metric Ton	0.866	900	100
	0.688	450	50
	0.546	225	5
0.91 Metric Ton	1.092	1,800	100
	0.866	900	50
	0.688	450	5
1.81 Metric Ton	1.375	3,600	100
	1.092	1,800	50
	0.866	900	5

¹Assuming a specific gravity of 2.65
²Based on AASHTO gradations

Riprap Class	Rock Size ¹ (ft)	Rock Size ² (lbs)	Percent of Riprap Smaller Than
Facing	1.30	200	100
	0.95	75	50
	0.40	5	10
Light	1.80	500	100
	1.30	200	50
	0.40	5	10
1/4 Ton	2.25	1,000	100
	1.80	500	50
	0.95	75	10
1/2 Ton	2.85	2,000	100
	2.25	1,000	50
	1.80	500	5
1 Ton	3.60	4,000	100
	2.85	2,000	50
	2.25	1,000	5
2 Ton	4.50	8,000	100
	3.60	4,000	50
	2.85	2,000	5

¹Assuming a specific gravity of 2.65
²Based on AASHTO gradations

Gradation of the riprap being placed is controlled by visual inspection. To aid the inspector's judgment, two or more samples of riprap of the specified gradation should be prepared by sorting, weighing, and remixing in proper proportions. Each sample should weigh about 5 to 10 tons. One sample should be placed at the quarry and one sample at the construction site. The sample at the construction site could be part of the finished riprap blanket. These samples should be used as a frequent reference for judging the gradation of the riprap supplied.⁽¹⁾

12.2.5 Filter Systems

A filter system should be provided to prevent the migration of the fine soil between the voids of the riprap. The system may be either a granular filter or an engineering filter fabric. Consultation with a geotechnical engineer may be useful in making the proper selection.

Granular Filters. In using a granular filter system, the filter ratio as stated in the following relationships should be met.

$$\frac{D_{15} \text{ (coarser layer)}}{D_{85} \text{ (finer layer)}} < 5 < \frac{D_{15} \text{ (coarser layer)}}{D_{15} \text{ (finer layer)}} < 40 \quad (12.4)$$

The left side of the inequality in Equation 12.4 is intended to prevent erosion (piping) through the filter and the center portion provides for adequate permeability for structural bedding. The right portion provides a uniformity criterion.

If a single layer of filter will not satisfy the equation, two or more layers must be used. The filter requirement applies between the bank material and the filter as well as the filter and the riprap. The thickness of the filter blanket should be from 150 mm (6 in) and 380 mm (15 in) for a single layer, or from 100 mm (4 in) to 200 mm (8 in) for individual layers of a multilayer installation.⁽¹⁾

Engineering Fabric Filters. For the proper design of a geotextile filter system, see Holtz et al. (FHWA HI-95-038).⁽⁴⁾ The fabric should provide drainage and filtration. Therefore, both functions should be considered in the selection of the filter material.

12.2.6 Edge Treatment

To prevent undermining at the toe and flanks of the riprap, special edge treatment may be required such as:

- Extending the lower toe of the riprap below the anticipated contraction scour and long-term degradation depth.
- Placing launchable stone at the toe of the installation that will slide into the scour hole as it develops. This method requires extra material to be placed at bottom of the installation in a trench or extending into the stream (Figures 12.2 and 12.3.). For additional information, see HEC-11.⁽¹⁾
- The flanks may be protected as illustrated in Figure 12.4. In Section A-A, the area shown as "compacted backfill" may be completely filled with riprap.

12.3 REVETMENT RIPRAP DESIGN EXAMPLE (SI)

The following design example illustrates the general revetment riprap design procedure. From a field survey of the site and an analysis of the stream using a water surface profile program such as WSPRO⁽⁶⁾ or HECRAS⁽⁷⁾ the following data have been established.

Given:

Channel width = 91.40 m
 Bend radius = 365.80 m

Average velocity in main channel (V_a) = 3.84 m/s
 Average depth in main channel (d_a) = 3.66 m

Available rock riprap has a specific gravity of 2.60 and is considered angular. A 1 vertical to 2 horizontal (1V:2H) bank slope is to be used.

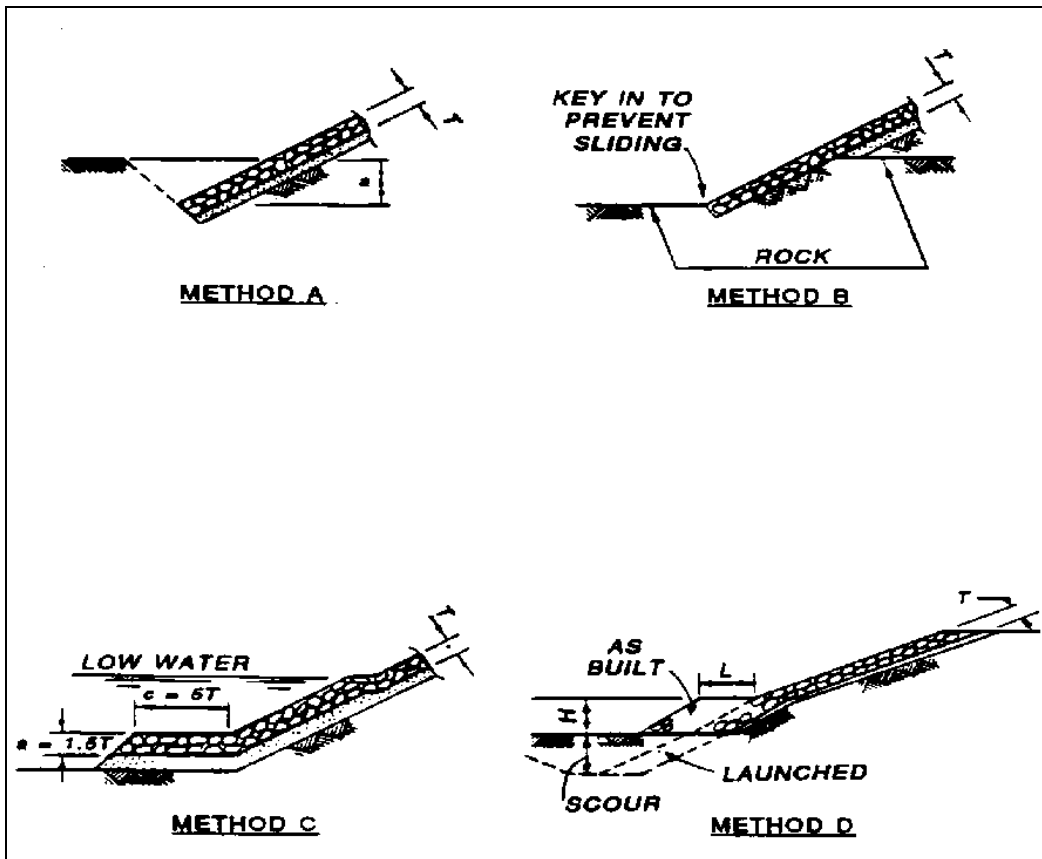

Figure 12.2. Methods of providing toe protection.⁽⁵⁾

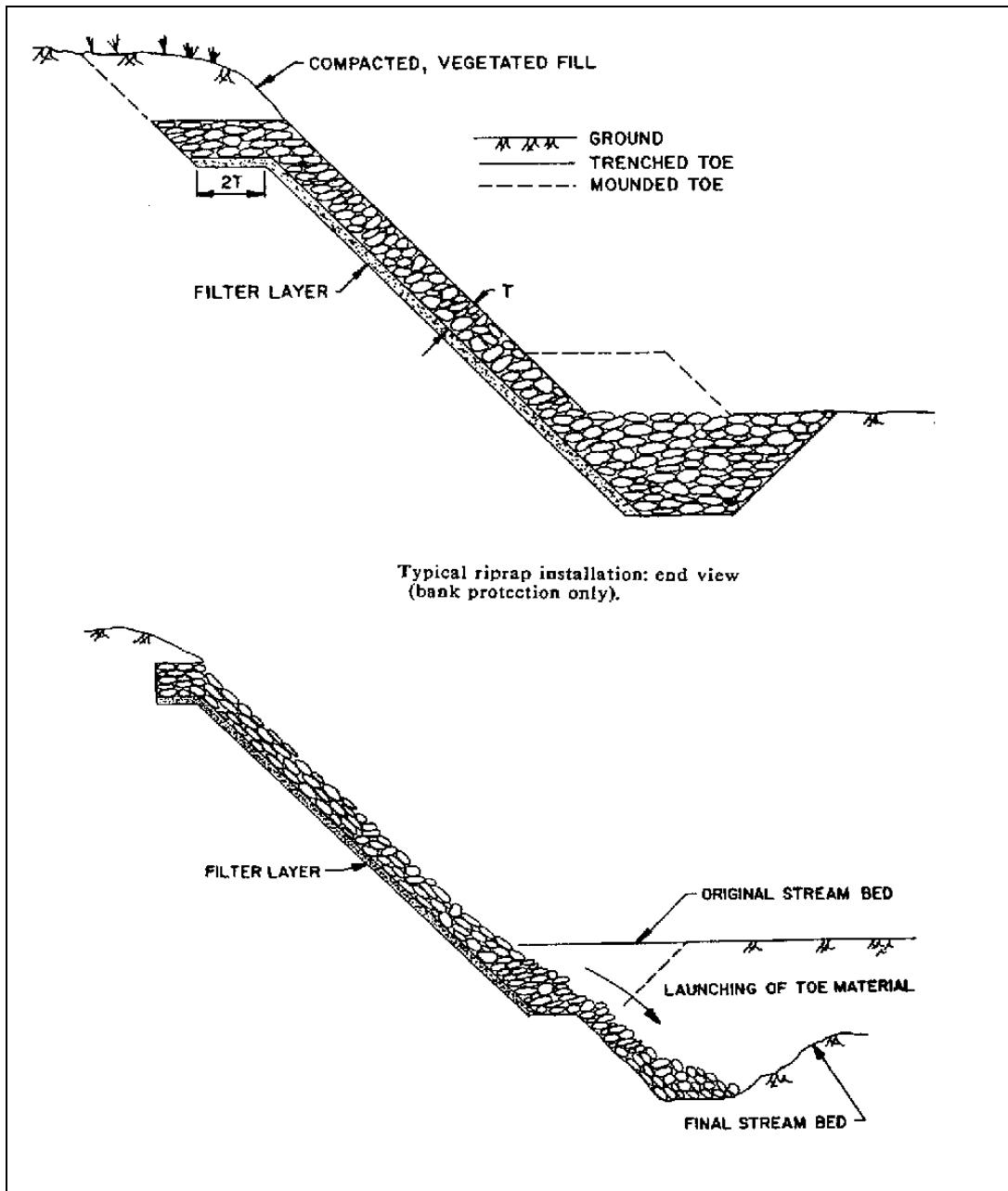

Figure 12.3. Alternative method of providing toe protection.⁽¹⁾

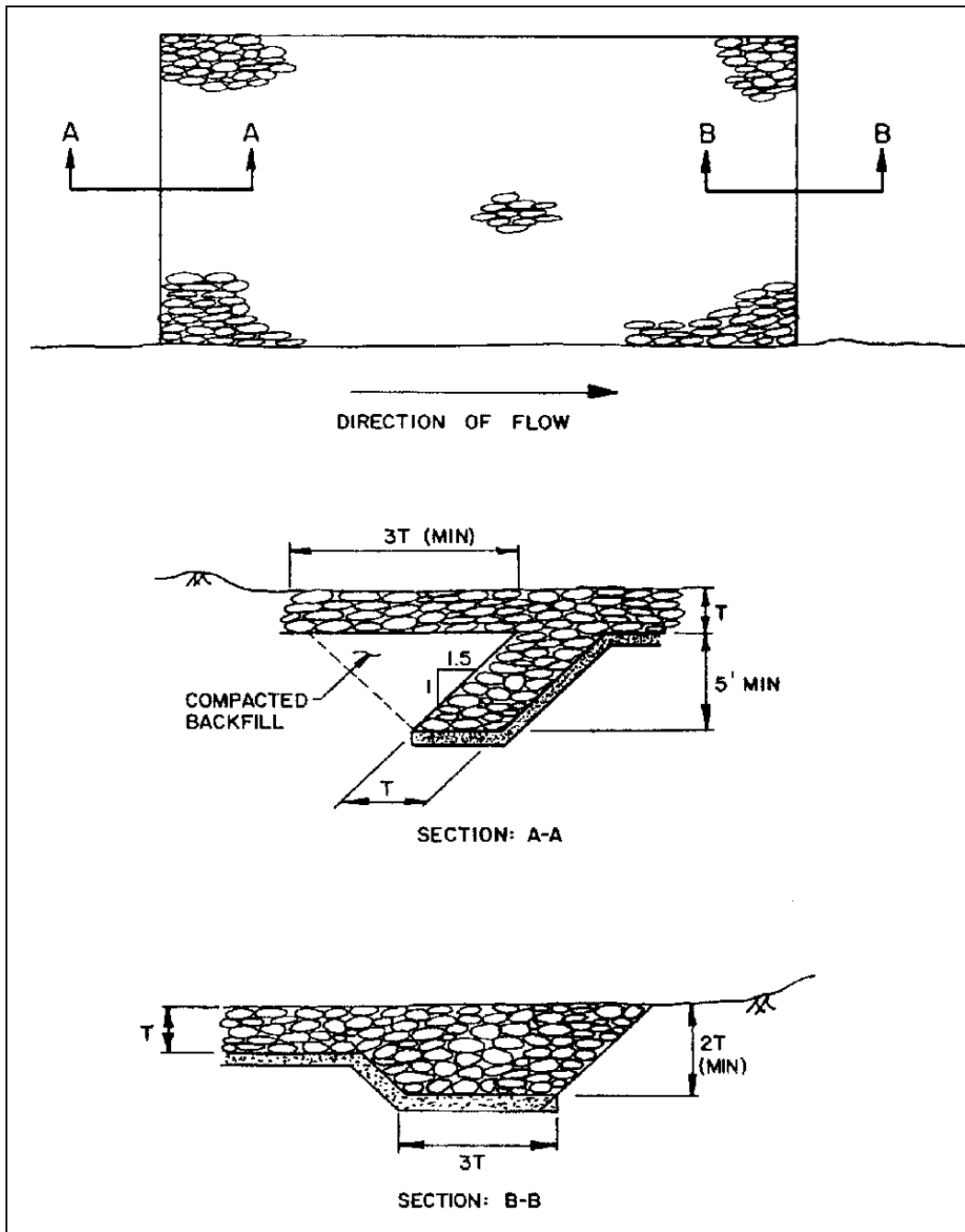

Figure 12.4. Flank details.⁽¹⁾

Solution:

Using Equations 12.1, 12.2, and 12.3, the following size is established.

$$D_{50} = \frac{K_u C V_a^3}{d_{avg}^{0.5} K_1^{1.5}} \quad K_1 = \left[1 - \frac{\sin^2 \theta}{\sin^2 \phi} \right]^{0.5} \quad C = \frac{1.61(SF)^{1.5}}{S_s - 1)^{1.5}}$$

From Figure 12.1 for angular stone, a value of 41° for the angle of repose would be a good initial estimate to use. For a side slope of 1V:2H:

$$\sin \theta = \frac{1}{\sqrt{5}} = 0.447 \quad \sin \phi = \sin 41^\circ = 0.656$$

$$K_1 = \left[1 - \frac{\sin^2 \theta}{\sin^2 \phi} \right]^{0.5} = \left[1 - \frac{(0.447)^2}{(0.656)^2} \right]^{0.5} = 0.73$$

Assuming for a gradually varying flow with moderate bend curvature, the stability factor (SF) is 1.6. (See the previous guidance for stability factor.)

$$C = \frac{1.61(SF)^{1.5}}{(S_s - 1)^{1.5}} = \frac{1.61(1.6)^{1.5}}{(2.60 - 1)^{1.5}} = 1.61$$

The required stone size is then found.

$$D_{50} = \frac{K_u C V_a^3}{d_{avg}^{0.5} K_1^{1.5}} = \frac{(0.0059)(1.61)(3.84)^3}{(3.66)^{0.5} (0.73)^{1.5}} = 0.45 \text{ m}$$

Using this stone size of 0.45 m, recheck the angle of repose. It would be close to the original 41° that was assumed and would be acceptable.

Taking this computed size of stone, compare it to a class of riprap that is available and use the next larger size (perhaps the AASHTO .23 metric ton class riprap).

The layer thickness would be twice the mean size ($2 D_{50}$) or the thickness equal to the D_{100} .

The need for a filter system depends on the parent material at the site. Normally a filter system will be required. It may be either a granular filter or a geotextile.

12.4 REVETMENT RIPRAP DESIGN EXAMPLE (English)

The following design example illustrates the general revetment riprap design procedure. From a field survey of the site and an analysis of the stream using a water surface profile program such as WSPRO⁽⁶⁾ or HECRAS⁽⁷⁾ the following data have been established.

Given:

Channel width	=	300 ft
Bend radius	=	1200 ft
Average velocity in main channel (V_a)	=	12.6 fps
Average depth in main channel (d_a)	=	12 ft

Available rock riprap has a specific gravity of 2.60 and is considered angular. A 1 vertical to 2 horizontal (1V:2H) bank slope is to be used.

Solution:

Using Equations 12.1, 12.2, and 12.3, the following size is established.

$$D_{50} = \frac{K_u C V_a^3}{d_{avg}^{0.5} K_1^{1.5}} \quad K_1 = \left[1 - \frac{\sin^2 \theta}{\sin^2 \phi} \right]^{0.5} \quad C = \frac{1.61(SF)^{1.5}}{S_s - 1)^{1.5}}$$

From Figure 12.1 for angular stone, a value of 41° for the angle of repose would be a good initial estimate to use. For a side slope of 1V:2H:

$$\sin \theta = \frac{1}{\sqrt{5}} = 0.447 \quad \sin \phi = \sin 41^\circ = 0.656$$

$$K_1 = \left[1 - \frac{\sin^2 \theta}{\sin^2 \phi} \right]^{0.5} = \left[1 - \frac{(0.447)^2}{(0.656)^2} \right]^{0.5} = 0.73$$

Assuming for a gradually varying flow with moderate bend curvature, the stability factor (SF) is 1.6. (See the previous guidance for stability factor.)

$$C = \frac{1.61(SF)^{1.5}}{(S_s - 1)^{1.5}} = \frac{1.61(1.6)^{1.5}}{(2.60 - 1)^{1.5}} = 1.61$$

The required stone size is then found.

$$D_{50} = \frac{K_u C V_a^3}{d_{avg}^{0.5} K_1^{1.5}} = \frac{(0.001)(1.61)(12.6)^3}{(12)^{0.5} (0.73)^{1.5}} = 1.5 \text{ ft}$$

Using this stone size of 1.5 ft, recheck the angle of repose. It would be close to the original 41° that was assumed and would be acceptable.

Taking this computed size of stone, compare it to a class of riprap that is available and use the next larger size (perhaps the AASHTO 1/4 ton class riprap).

The layer thickness would be twice the mean size ($2 D_{50}$) or the thickness equal to the D_{100} .

The need for a filter system depends on the parent material at the site. Normally a filter system will be required. It may be either a granular filter or a geotextile.

12.5 ROCK-FILL TRENCHES AND WINDROW REVETMENT

Rock-fill trenches are structures used to protect banks from caving caused by erosion at the toe. A trench is excavated along the toe of the bank and filled with rocks as shown in Figure 12.5. The size of trench to hold the rock fill depends on expected depths of scour.

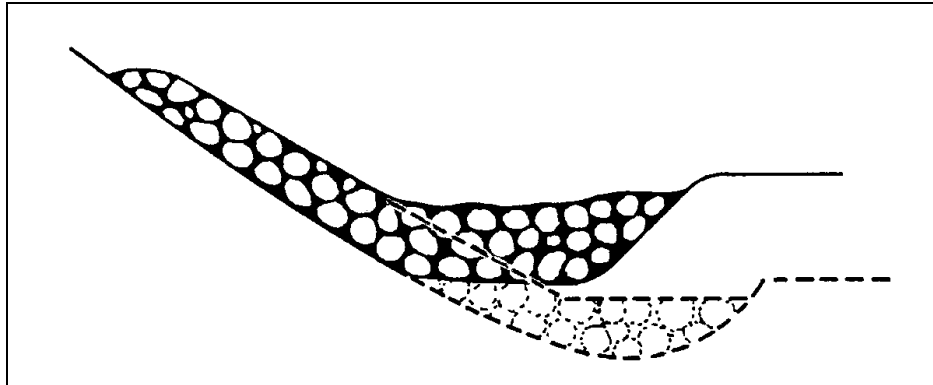

Figure 12.5. Rock-fill trench (after HDS 6).⁽⁸⁾

As the streambed adjacent to the toe is eroded, the toe trench is undermined and the rock fill slides downward to pave the bank. It is advantageous to grade the banks before placing riprap on the slope and in the toe trench. The slope should be at such an angle that the saturated bank is stable while the stream stage is falling.

An alternative to a rock-fill trench at the toe of the bank is to excavate a trench above the water line along the top of the bank and fill the trench with rocks. As the bank erodes, stone material in the trench is added on an as-needed basis until equilibrium is established. This method is applicable in areas of rapidly eroding banks of medium to large size streams.

Windrow revetment (Figure 12.6) consists of a supply of rock deposited along an existing bank line at a location beyond which additional erosion is to be prevented. When bank erosion reaches and undercuts the supply of rock, it falls onto the eroding area, thus giving protection against further undercutting. The resulting bank line remains in a near natural state with an irregular appearance due to intermittent lateral erosion in the windrow location. The treatment particularly lends itself to the protection of adjacent wooded areas, or placement along stretches of presently eroding, irregular bank line.

The effect of windrow revetment on the interchange of flow between the channel and overbank areas and flood flow distribution in the flood plain should be carefully evaluated. Windrow installations will perform as guide banks or levees and may adversely affect flow distribution at bridges or cause local scour. Tying the windrow to the highway embankment at an abutment would be contrary to the purpose of the windrow since the rock is intended to fall into the channel as the bank erodes. This would potentially expose the abutment.

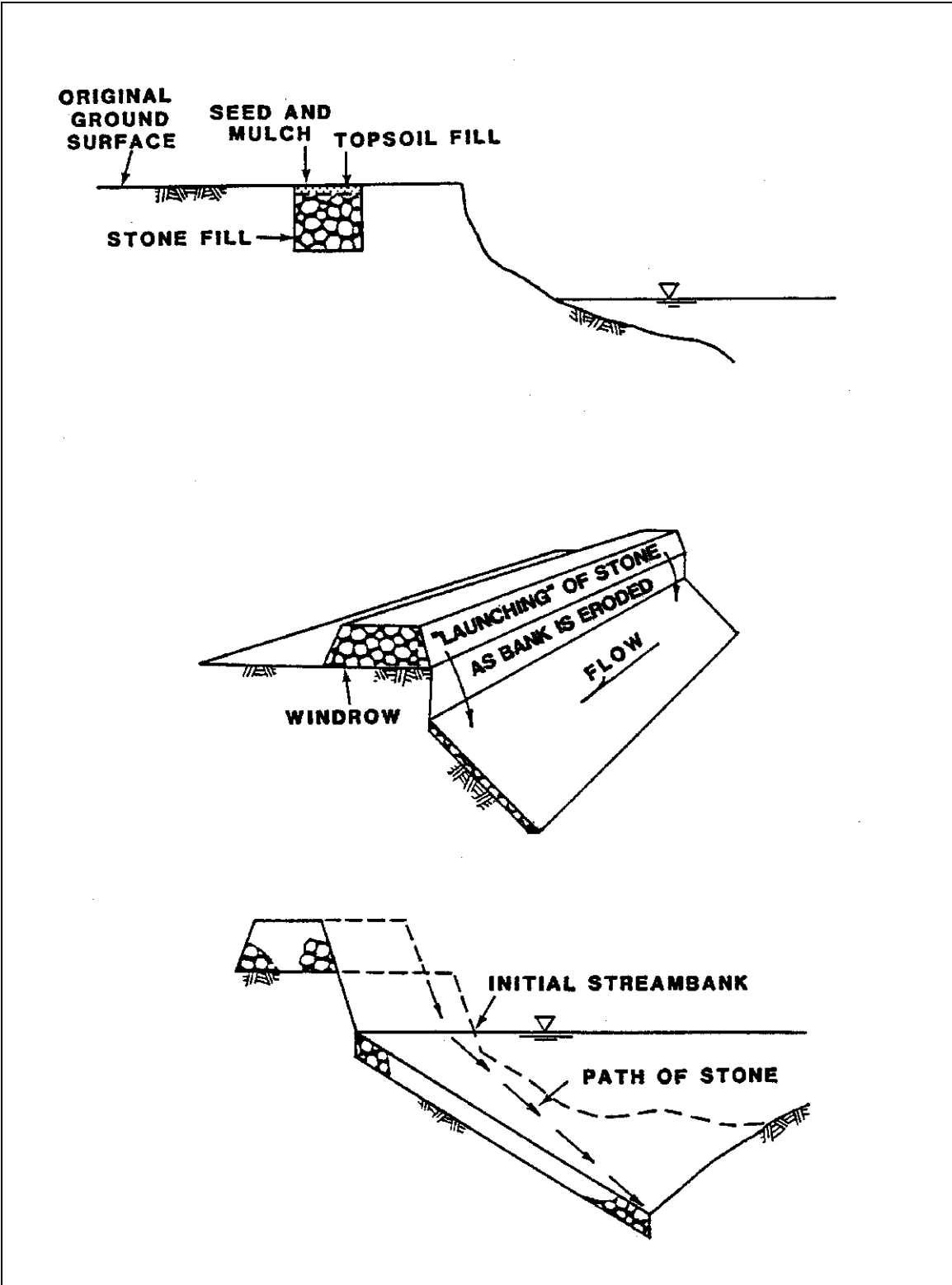

Figure 12.6. Windrow revetment, definition sketch (after USACE).⁽⁹⁾

The following observations and conclusions from model investigations of windrow revetments and rock-fill trenches may be used as design guidance. More definitive guidance is not presently available.⁽⁹⁾

- The application rate of stone is a function of channel depth, bank height, material size, and estimated bed scour.
- A triangular windrow is the least desirable shape, a trapezoidal shape provides a uniform blanket of rock on an eroding bank, and a rectangular shape provides the best coverage. A rectangular shape is most easily placed in an excavated trench.
- Bank height does not significantly affect the final revetment; however, high banks tend to produce a nonuniform revetment alignment. Large segments of bank tend to break loose and rotate slightly on high banks, whereas low banks simply "melt" or slough into the stream.
- Stone size influences the thickness of the final revetment, and a smaller gradation of stone forms a more dense, closely chinked protective layer. Stones must be large enough to resist being transported by the stream, and a well-graded stone should be used to ensure that the revetment does not fail from leaching of the underlying bank material. Large stone sizes require more material than smaller stone sizes to produce the same relative thickness of revetment. In general, the greater the stream velocity, the steeper the side slope of the final revetment. The final revetment slope will be about 15 percent flatter than the initial bank slope.
- A windrow segment should be extended landward from the upstream end to reduce the possibility of outflanking of the windrow.

12.6 USED TIRE REVETMENTS

Used tire revetments have been successfully used for velocities up to 3 m/s (10 ft/s) on mild bends. They will accommodate a limited amount of bank subsidence, but usually will be damaged where substantial subsidence occurs. They are not well-suited for use where scour at the toe of the installation would undermine the revetment, but a riprap launching apron or toe trench will alleviate this problem to some extent. Used tire revetments are somewhat unsightly and vandalism has proved to be more of a problem than for other types of bank protection. Construction is labor-intensive and is therefore expensive.

The following precautions should be followed to ensure that the mattress will stay in place on an eroding bank:

- The tires must be banded together; alternatively, cable running the length and width of the mattress can be woven through the tires.
- The top, toe and the upstream and downstream ends of the mattress must be tied to the bank (Figure 12.7). Riprap should be placed at the toe of the mattress for protection against scour.

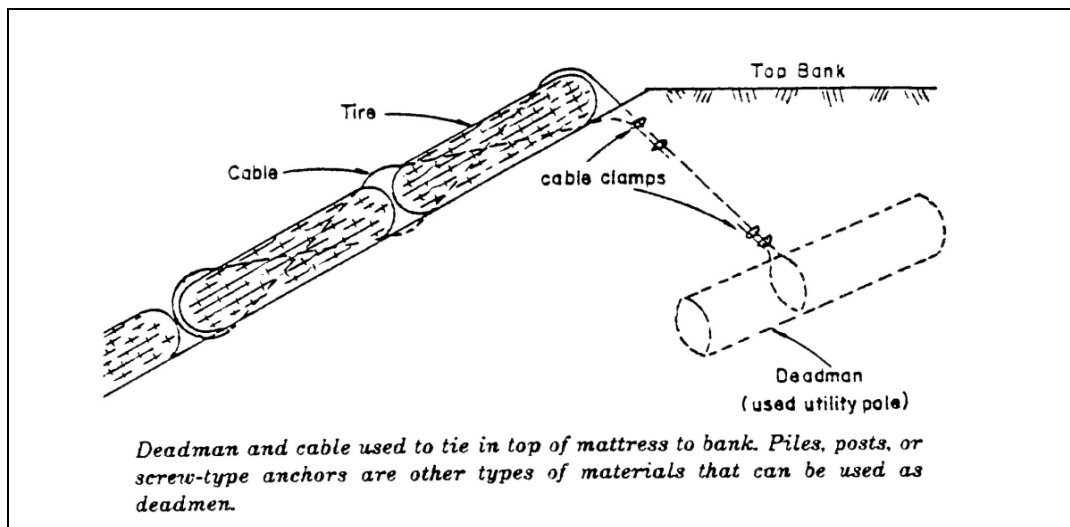

Figure 12.7. Used tire mattress (after Keown).⁽¹⁰⁾

While the above precautions are essential to a stable mattress, other measures can also help to ensure stability. They are:

- Cut, drill or burn holes in the tire sidewalls to prevent flotation.
- Sort the tires by size to help in fitting them together.
- Fasten the mattress to the bank at intervals with earth screw anchors (or some other type of anchor).
- Pack the tires with stone or rubble.
- Plant willows or other fast growing, thick brush inside the tires. Once established, the root system will strengthen the bank and the willows will obscure the somewhat unsightly mattress and decrease flow velocities near the bank. If willows are not readily available, other species should be planted. Possible species for use are discussed under vegetation.

If the mattress effectively controls the streambank erosion and remains intact, sediment may gradually cover the revetment. If willows have not been planted, volunteer vegetation may become established.

12.7 VEGETATION

Vegetation is the most natural method for protecting streambanks because it is relatively easy to establish and maintain and is visually attractive. However, vegetation should not be seriously considered as a countermeasure against severe bank erosion where a highway facility is at risk. At such locations, vegetation can best serve to supplement other countermeasures (see Chapter 4, Section 4.7, "Biotechnical Engineering").

Vegetation can effectively protect a bank below the water line in two ways. First, the root system helps to hold the soil together and increases overall bank stability by forming a binding network. Second, the exposed stalks, stems, branches and foliage provide resistance to flow, causing the flow to lose energy by deforming the plants rather than by removing soil particles. Above the water line, vegetation prevents surface erosion by absorbing the impact of falling raindrops and reducing the velocity of overbank flow and rainfall runoff. Further, vegetation provides additional capacity for infiltration by taking water from the soil, and may improve bank stability by water withdrawal.

Vegetation is generally divided into two broad categories: grasses and woody plants (trees and shrubs). A major factor affecting species selection is the length of time required for the plant to become established on the slope. Grasses are less costly to plant on an eroding bank and require a shorter period of time to become established. Woody plants offer greater protection against erosion because of more extensive root systems; however, under some conditions the weight of the plant will offset the advantage of the root system. On high banks, tree root systems may not penetrate to the toe of the bank. If the toe becomes eroded, the weight of the tree and its root mass may cause a bank failure.

Water-tolerant grasses such as canarygrass (*Phalaris*), reedgrass (*Calamagrostis*), cordgrass (*Spartina*), and fescue (*Festuca*) are effective in preventing erosion on upper banks which are inundated from time to time and are subject to erosion due primarily to rainfall, overland flow, and minor wave action. Along the lower bank, where erosive forces are high, vegetation is generally not effective as a protective measure; however, cattails (*Typha*), bulrushes (*Scripus*), reeds (*Phragmites*), knotweed and smartweed (*Polygonum*), rushes (*Juncus*), and mannagrass (*Glyceria*) are helpful in inducing deposition and reducing velocities in shallow water or wet areas at the bank toe and in protecting the bank in some locations. Willows (*Salix*) are among the most effective woody plants in protecting low banks because they are resilient, are sufficiently dense to promote deposition of sediment, can withstand inundation, and easily become established.

12.8 RIGID REVETMENTS

Rigid revetments are generally smoother than flexible revetments and thus improve hydraulic efficiency and are generally highly resistant to erosion and impact damage. They are susceptible to damage from the removal of foundation support by subsidence, undermining, hydrostatic pressures, slides, and erosion at the perimeter. They are also among the most expensive streambank protection countermeasures. The following provide additional guidance on rigid revetments:

- Soil Cement - Design Guideline 2
- Grouted and Partially Grouted Riprap - Chapter 4, Section 4.4

12.9 CONCRETE PAVEMENT

Concrete paving should be used only where the toe can be adequately protected from undermining and where hydrostatic pressures behind the paving will not cause failure. This might include impermeable bank materials and portions of banks which are continuously under water. Sections intermittently above water should be provided with weep holes. Refer to HEC-11 for design of concrete pavement revetment.⁽¹⁾

12.10 SACKS

Burlap sacks filled with soil or sand-cement mixtures have long been used for emergency work along levees and streambanks during floods (Figure 12.8). Commercially manufactured sacks (burlap, paper, plastics, etc.) have been used to protect streambanks in areas where riprap of suitable size and quality is not available at a reasonable cost. Sacks filled with sand-cement mixtures can provide long-term protection if the mixture has set up properly, even though most types of sacks are easily damaged and will eventually deteriorate. Sand-cement sack revetment construction is not economically competitive in areas where good stone is available. However, where quality riprap must be transported over long distances, sack revetment can often be placed at a lesser cost than riprap.

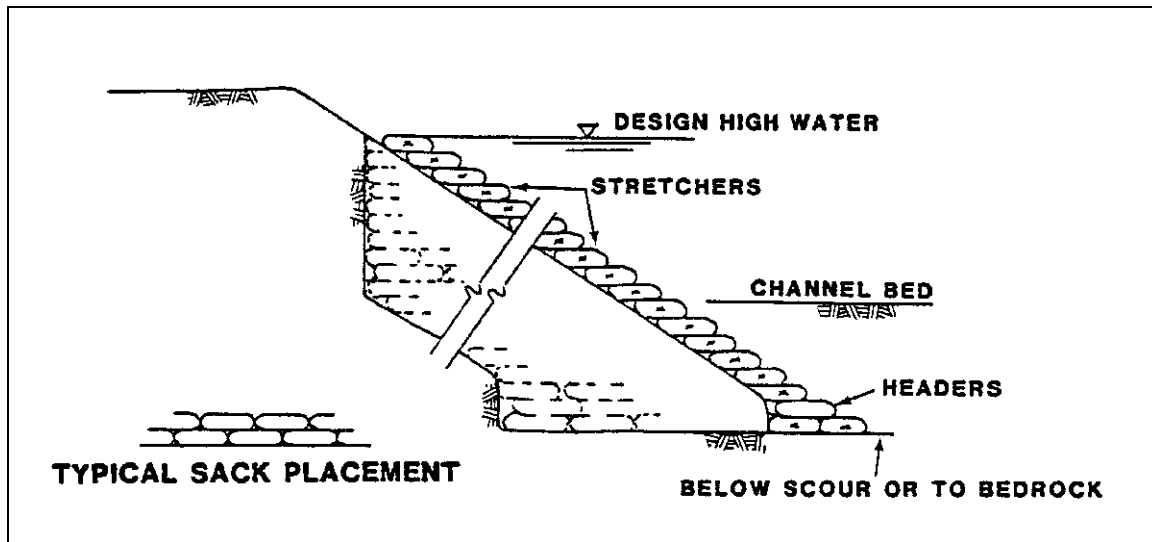

Figure 12.8. Typical sand-cement bag revetment (Modified from California Department of Public Works, 1970 (after Brown)).⁽¹¹⁾

If a sack revetment is to be constructed, the sacks should be filled with a mixture of 15 percent cement (minimum) and 85 percent dry sand (by weight). The filled sacks should be placed in horizontal rows like common house brick beginning at an elevation below any toe scour (alternatively, riprap can be placed at the toe to prevent undermining of the bank slope). The successive rows should be stepped back approximately one-half-bag width to a height on the bank above which no protection is needed. The slope of the completed revetment should not be steeper than 1:1. After the sacks have been placed on the bank, they can be wetted down for a quick set or the sand-cement mixture can be allowed to set up naturally through rainfall, seepage or condensation. If cement leaches through the sack material, a bond will form between the sacks and prevent free drainage. For this reason, weepholes should be included in the revetment design. The installation of weepholes will allow drainage of groundwater from behind the revetment thus helping to prevent a pressure buildup that could cause revetment failure. This revetment requires the same types of toe protection as other types of rigid revetment.

12.11 REFERENCES

1. Brown, S.A. and E.S. Clyde, 1989, "Design of Riprap Revetment," Hydraulic Engineering Circular No.11, FHWA-IP-89-016. Prepared for the Federal Highway Administration, Washington, D.C.
2. Chen, Y.H. and G.K. Cotton, 1988, "Design of Roadway Channels with Flexible Linings," U.S. Department of Transportation, Federal Highway Administration, FHWA IP87-7, NTIS PB89-122584, Hydraulic Engineering Circular No. 15
3. AASHTO, 1999, "Model Drainage Manual," Metric Edition, American Association of State Highway and Transportation Officials, Washington, D.C.
4. Holtz, D.H., B.R. Christopher, and R.R. Berg, 1995, "Geosynthetic Design and Construction Guidelines," National Highway Institute, Publication No. FHWA HI-95-038, Federal Highway Administration, Washington, D.C., May.
5. U.S. Army Corps of Engineers, 1991, "Hydraulic Design of Flood Control Channels," EM 1110-2-1601, Department of the Army, Washington, D.C.
6. Arneson, L.A. and J.O. Shearman, 1987, Users Manual for WSPRO - A Computer Model for Water Surface Profile Computations, Office of Technology Applications, Federal Highway Administration, FHWA Report No. FHWA-SA-98-080, June 1998.
7. Hydrologic Engineer Center, 1998, "HEC-RAS River Analysis System," Hydraulic Reference Manual, Version 2.2, U.S. Army Corps of Engineers, Davis, CA.
8. Richardson, E.V., D.B. Simons, and P.F. Lagasse, 2001, "River Engineering for Highway Encroachments - Highways in the River Environment," Report No. FHWA NHI 01-004, Hydraulic Design Series No. 6, Federal Highway Administration, Washington, D.C.
9. U.S. Army Corps of Engineers, 1981, "The Streambank Erosion Control Evaluation and Demonstration Act of 1974," Final Report to Congress, Executive Summary and Conclusions.
10. Keown, M.P., 1983, "Streambank Protection Guidelines for Landowners and Local Governments," U.S. Army Corps of Engineers, Waterways Experiment Station, Vicksburg, MS.
11. Brown, S.A., 1985, "Streambank Stabilization Measures for Highway Engineers," FHWA/RD-84, 100 Federal Highway Administration, McLean, VA.

APPENDIX A
METRIC SYSTEM, CONVERSION FACTORS, AND WATER PROPERTIES

(page intentionally left blank)

APPENDIX A

Metric System, Conversion Factors, and Water Properties

The following information is summarized from the Federal Highway Administration, National Highway Institute (NHI) Course No. 12301, "Metric (SI) Training for Highway Agencies." For additional information, refer to the Participant Notebook for NHI Course No. 12301.

In SI there are seven base units, many derived units and two supplemental units (Table A.1). Base units uniquely describe a property requiring measurement. One of the most common units in civil engineering is length, with a base unit of meters in SI. Decimal multiples of meter include the kilometer (1000m), the centimeter (1m/100) and the millimeter (1 m/1000). The second base unit relevant to highway applications is the kilogram, a measure of mass which is the inertial of an object. There is a subtle difference between mass and weight. In SI, mass is a base unit, while weight is a derived quantity related to mass and the acceleration of gravity, sometimes referred to as the force of gravity. In SI the unit of mass is the kilogram and the unit of weight/force is the newton. Table A.2 illustrates the relationship of mass and weight. The unit of time is the same in SI as in the English system (seconds). The measurement of temperature is Centigrade. The following equation converts Fahrenheit temperatures to Centigrade, $^{\circ}\text{C} = 5/9 (^{\circ}\text{F} - 32)$.

Derived units are formed by combining base units to express other characteristics. Common derived units in highway drainage engineering include area, volume, velocity, and density. Some derived units have special names (Table A.3).

Table A.4 provides useful conversion factors from English to SI units. The symbols used in this table for metric units, including the use of upper and lower case (e.g., kilometer is "km" and a newton is "N") are the standards that should be followed. Table A.5 provides the standard SI prefixes and their definitions.

Table A.6 provides physical properties of water at atmospheric pressure in SI system of units. Table A.7 gives the sediment grade scale and Table A.8 gives some common equivalent hydraulic units.

Table A.1. Overview of SI Units.		
	Units	Symbol
Base units		
length	meter	m
mass	kilogram	kg
time	second	s
temperature*	kelvin	K
electrical current	ampere	A
luminous intensity	candela	cd
amount of material	mole	mol
Derived units		
Supplementary units		
angles in the plane	radian	rad
solid angles	steradian	sr
*Use degrees Celsius ($^{\circ}\text{C}$), which has a more common usage than kelvin.		

Table A.2. Relationship of Mass and Weight.			
	Mass	Weight or Force of Gravity	Force
English	slug pound-mass	pound pound-force	pound pound-force
metric	kilogram	newton	newton

Table A.3. Derived Units With Special Names.			
Quantity	Name	Symbol	Expression
Frequency	hertz	Hz	s^{-1}
Force	newton	N	$kg \cdot m/s^2$
Pressure, stress	pascal	Pa	N/m^2
Energy, work, quantity of heat	joule	J	$N \cdot m$
Power, radiant flux	watt	W	J/s
Electric charge, quantity	coulomb	C	$A \cdot s$
Electric potential	volt	V	W/A
Capacitance	farad	F	C/V
Electric resistance	ohm	Ω	V/A
Electric conductance	siemens	S	A/V
Magnetic flux	weber	Wb	$V \cdot s$
Magnetic flux density	tesla	T	Wb/m^2
Inductance	henry	H	Wb/A
Luminous flux	lumen	lm	$cd \cdot sr$
Illuminance	lux	lx	lm/m^2

Table A.4. Useful Conversion Factors.			
Quantity	From English Units	To Metric Units	Multiplied By*
Length	mile	km	1.609
	yard	m	0.9144
	foot	m	<u>0.3048</u>
	inch	mm	<u>25.40</u>
Area	square mile	km ²	2.590
	acre	m ²	4047
	acre	hectare	0.4047
	square yard	m ²	0.8361
	square foot	m ²	0.09290
Volume	square inch	mm ²	645.2
	acre foot	m ³	1233
	cubic yard	m ³	0.7646
	cubic foot	m ³	0.02832
	cubic foot	L (1000 cm ³)	28.32
	100 board feet	m ³	0.2360
Mass	gallon	L (1000 cm ³)	3.785
	cubic inch	cm ³	16.39
Mass	lb	kg	0.4536
	kip (1000 lb)	metric ton (1000 kg)	0.4536
Mass/unit length	plf	kg/m	1.488
Mass/unit area	psf	kg/m ²	4.882
Mass density	pcf	kg/m ³	16.02
Force	lb	N	4.448
	kip	kN	4.448
Force/unit length	plf	N/m	14.59
	klf	kN/m	14.59
Pressure, stress, modulus of elasticity	psf	Pa	47.88
	ksf	kPa	47.88
	psi	kPa	6.895
	ksi	MPa	6.895
Bending moment, torque, moment of force	ft-lb	N · m	1.356
	ft-kip	kN · m	1.356
Moment of mass	lb · ft	m	0.1383
Moment of inertia	lb · ft ²	kg · m ²	0.04214
Second moment of area	in ⁴	mm ⁴	416200
Section modulus	in ³	mm ³	16390
Power	ton (refrig)	kW	3.517
	Btu/s	kW	1.054
	hp (electric)	W	745.7
	Btu/h	W	0.2931

*4 significant figures; underline denotes exact conversion

Table A.4. Useful Conversion Factors (continued).			
Quantity	From English Units	To Metric Units	Multiplied by*
Volume rate of flow	ft ³ /s	m ³ /s	0.02832
	cfm	m ³ /s	0.0004719
	cfm	L/s	0.4719
	mgd	m ³ /s	0.0438
Velocity, speed	ft/s	m/s	<u>0.3048</u>
Acceleration	f/s ²	m/s ²	<u>0.3048</u>
Momentum	lb · ft/sec	kg · m/s	0.1383
Angular momentum	lb · ft ² /s	kg · m ² /s	0.04214
Plane angle	degree	rad	0.01745
		mrاد	17.45
*4 significant figures; underline denotes exact conversion			

Table A.5. Prefixes.					
Submultiples			Multiples		
deci	10 ⁻¹	d	deka	10 ¹	da
centi	10 ⁻²	c	hecto	10 ²	h
milli	10 ⁻³	m	kilo	10 ³	k
micro	10 ⁻⁶	μ	mega	10 ⁶	M
nano	10 ⁻⁹	n	giga	10 ⁹	G
pica	10 ⁻¹²	p	tera	10 ¹²	T
femto	10 ⁻¹⁵	f	peta	10 ¹⁵	P
atto	10 ⁻¹⁸	a	exa	10 ¹⁸	E
zepto	10 ⁻²¹	z	zetta	10 ²¹	Z
yocto	10 ⁻²⁴	y	yotta	10 ²⁴	Y

Table A.6. Physical Properties of Water at Atmospheric Pressure in SI Units.									
Temperature		Density	Specific Weight	Dynamic Viscosity	Kinematic Viscosity	Vapor Pressure	Surface Tension ¹	Bulk Modulus	
Centigrade	Fahrenheit	kg/m ³	N/m ³	N · s/m ²	m ² /s	N/m ² abs.	N/m	GN/m ²	
0°	32°	1,000	9,810	1.79 x 10 ⁻³	1.79 x 10 ⁻⁶	611	0.0756	1.99	
5°	41°	1,000	9,810	1.51 x 10 ⁻³	1.51 x 10 ⁻⁶	872	0.0749	2.05	
10°	50°	1,000	9,810	1.31 x 10 ⁻³	1.31 x 10 ⁻⁶	1,230	0.0742	2.11	
15°	59°	999	9,800	1.14 x 10 ⁻³	1.14 x 10 ⁻⁶	1,700	0.0735	2.16	
20°	68°	998	9,790	1.00 x 10 ⁻³	1.00 x 10 ⁻⁶	2,340	0.0728	2.20	
25°	77°	997	9,781	8.91 x 10 ⁻⁴	8.94 x 10 ⁻⁷	3,170	0.0720	2.23	
30°	86°	996	9,771	7.97 x 10 ⁻⁴	8.00 x 10 ⁻⁷	4,250	0.0712	2.25	
35°	95°	994	9,751	7.20 x 10 ⁻⁴	7.24 x 10 ⁻⁷	5,630	0.0704	2.27	
40°	104°	992	9,732	6.53 x 10 ⁻⁴	6.58 x 10 ⁻⁷	7,380	0.0696	2.28	
50°	122°	988	9,693	5.47 x 10 ⁻⁴	5.53 x 10 ⁻⁷	12,300	0.0679		
60°	140°	983	9,643	4.66 x 10 ⁻⁴	4.74 x 10 ⁻⁷	20,000	0.0662		
70°	158°	978	9,594	4.04 x 10 ⁻⁴	4.13 x 10 ⁻⁷	31,200	0.0644		
80°	176°	972	9,535	3.54 x 10 ⁻⁴	3.64 x 10 ⁻⁷	47,400	0.0626		
90°	194°	965	9,467	3.15 x 10 ⁻⁴	3.26 x 10 ⁻⁷	70,100	0.0607		
100°	212°	958	9,398	2.82 x 10 ⁻⁴	2.94 x 10 ⁻⁷	101,300	0.0589		

¹Surface tension of water in contact with air

Table A.7. Physical Properties of Water at Atmospheric Pressure in English Units.									
Temperature		Density	Specific Weight	Dynamic Viscosity	Kinematic Viscosity	Vapor Pressure	Surface Tension ¹	Bulk Modulus	
Fahrenheit	Centigrade	Slugs/ft ³	Weight lb/ft ³	lb-sec/ft ²	ft ² /sec	lb/in ²	lb/ft	lb/in ²	lb/in ²
32	0	1.940	62.416	0.374 X 10 ⁻⁴	1.93 X 10 ⁻⁵	0.09	0.00518		287,000
39.2	4.0	1.940	62.424						
40	4.4	1.940	62.423	0.323	1.67	0.12	.00514		296,000
50	10.0	1.940	62.408	0.273	1.41	0.18	.00508		305,000
60	15.6	1.939	62.366	0.235	1.21	0.26	.00504		313,000
70	21.1	1.936	62.300	0.205	1.06	0.36	.00497		319,000
80	26.7	1.934	62.217	0.180	0.929	0.51	.00492		325,000
90	32.2	1.931	62.118	0.160	0.828	0.70	.00486		329,000
100	37.8	1.927	61.998	0.143	0.741	0.95	.00479		331,000
120	48.9	1.918	61.719	0.117	0.610	1.69	.00466		332,000
140	60.0	1.908	61.386	0.0979	0.513	2.89			
160	71.1	1.896	61.006	0.0835	0.440	4.74			
180	82.2	1.883	60.586	0.0726	0.385	7.51			
200	93.3	1.869	60.135	0.0637	0.341	11.52			
212	100	1.847	59.843	0.0593	0.319	14.70			

¹Surface tension of water in contact with air

Table A.8. Sediment Particles Grade Scale.									
Size						Approximate Sieve Mesh Openings Per Inch		Class	
Millimeters	Microns	Inches	Tyler	U.S. Standard					
4000-2000	-----	160-80	----	-----					Very large boulders
2000-1000	-----	80-40	-----	-----					Large boulders
1000-500	-----	40-20	-----	-----					Medium boulders
500-250	-----	20-10	-----	-----					Small boulders
250-130	-----	10-5	-----	-----					Large cobbles
130-64	-----	5-2.5	-----	-----					Small cobbles
64-32	-----	2.5-1.3	-----	-----					Very coarse gravel
32-16	-----	1.3-0.6	-----	-----					Coarse gravel
16-8	-----	0.6-0.3	2 1/2	-----					Medium gravel
8-4	-----	0.3-0.16	5	-----					Fine gravel
4-2	-----	0.16-0.08	9	-----					Very fine gravel
2-1	2.00-1.00	-----	16	-----					Very coarse sand
1-1/2	1.00-0.50	-----	32	-----					Coarse sand
1/2-1/4	0.50-0.25	-----	60	-----					Medium sand
1/4-1/8	0.25-0.125	-----	115	-----					Fine sand
1/8-1/16	0.125-0.062	-----	250	-----					Very fine sand
1/16-1/32	0.062-0.031	-----	-----	-----					Coarse silt
1/32-1/64	0.031-0.016	-----	-----	-----					Medium silt
1/64-1/128	0.016-0.008	-----	-----	-----					Fine silt
1/128-1/256	0.008-0.004	-----	-----	-----					Very fine silt
1/256-1/512	0.004-0.0020	-----	-----	-----					Coarse clay
1/512-1/1024	0.0020-0.0010	-----	-----	-----					Medium clay
1/1024-1/2048	0.0010-0.0005	-----	-----	-----					Fine clay
1/2048-1/4096	0.0005-0.0002	0.5-0.24	-----	-----					Very fine clay

Table A.9. Common Equivalent Hydraulic Units.

Volume										
Unit	Equivalent									
	cubic inch	liter	u.s. gallon	cubic foot	cubic yard	cubic meter	acre-foot	sec-foot-day		
liter	61.02	1	0.264 2	0.035 31	0.001 308	0.001	810.6 E - 9	408.7 E - 9		
U.S. gallon	231.0	3.785	1	0.133 7	0.004 951	0.003 785	3.068 E - 6	1.547 E - 6		
cubic foot	1728	28.32	7.481	1	0.037 04	0.028 32	22.96 E - 6	11.57 E - 6		
cubic yard	46 660	764.6	202.0	27	1	0.746 6	619.8 E - 6	312.5 E - 6		
meter ³	61 020	1000	264.2	35.31	1.308	1	810.6 E - 6	408.7 E - 6		
acre-foot	75.27 E + 6	1 233 000	325 900	43 560	1 613	1 233	1	0.504 2		
sec-foot-day	149.3 E + 6	2 447 000	646 400	86 400	3 200	2 447	1.983	1		
Discharge (Flow Rate, Volume/Time)										
Unit	Equivalent									
	gallon/minute	liter/second	acre-foot/day	foot ³ /sec	million gal/day	meter ³ /sec				
gallon/minute	1	0.063 09	0.004 419	0.002 228	0.001 440	63.09 E - 6				
liter/second	15.85	1	0.070 05	0.035 31	0.022 82	0.001				
acre-foot/day	226.3	14.28	1	0.504 2	0.325 9	0.014 28				
feet ³ /second	448.8	28.32	1.983	1	0.646 3	0.028 32				
million gal/day	694.4	43.81	3.068	1.547	1	0.043 82				
meter ³ /second	15 850	1000	70.04	35.31	22.82	1				

(page intentionally left blank)