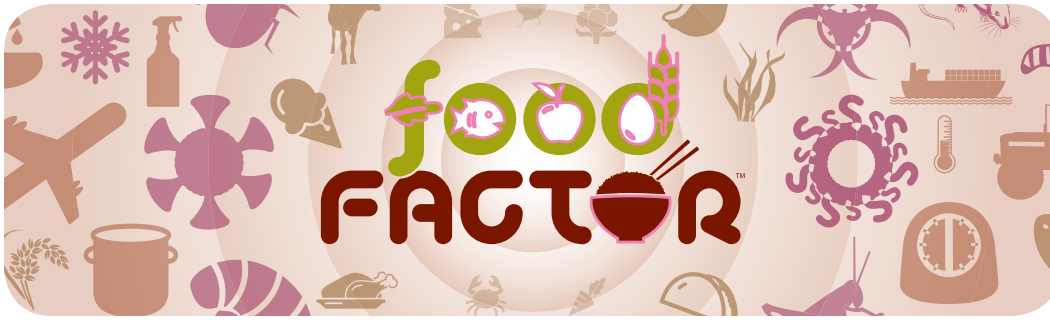



table of contents

Robot Game — Field Setup	2
Robot Game — Missions.....	8
Robot Game — Rules, Procedures, Philosophies and Definitions	11



2011 FLL CHALLENGE

robot game – field setup

OVERVIEW

- The field is where the Robot Game takes place.
- It consists of a field mat, on a table, with mission models arranged on top.
- The field mat and the LEGO® pieces for building the mission models are part of your Field Setup Kit.
- The instructions for building the mission models are on a CD, in the same box as the LEGO pieces.
- The instructions for how to build the table and how to arrange everything on it are in this document.

TABLE CONSTRUCTION

The Robot Game takes place on a specially designed table, so you'll need to build one to practice on if you don't already have access to one. With safety, weight, height, and cost in mind, a simple design is offered here, but as long as your surface is smooth, and your border walls are located properly, how you build the understructure is up to you. The construction is simple, but does require some wood-working skills.

At a tournament, two tables are placed back to back, but you only operate on one table, so you only need to build one table to practice on. However, since a tournament setup has a double wall at the interactive area where the two tables meet, practice tables need an extra wall of type B on the corresponding side. So here are the instructions for building one "half-table" including a double north wall:

MATERIALS

Material	Quantity
Field Setup Kit (mission model LEGO elements, mat, CD, Dual Lock™)	1
sanded plywood (or other very smooth board) 96" X 48" X 3/8" or thicker	1
two-by-three, 8' (actual cross-section = 1-1/2" by 2-1/2")	6
flat black paint	1 pt.
coarse drywall screws, 6 X 2-1/2"	1/2 lb.
saw horses, about 24" high and 36" wide	2

PARTS

Part	Make From	Dimensions	Paint	Quantity
table surface (A)	plywood	96" X 48"	no	1
long border wall (B)	two-by-three	96"	yes	3
short border wall (C)	two-by-three	45"	yes	2
stiffener (D)	two-by-three	48"	no	4
saw horse	purchase	H ≈ 24" W ≈ 36"	no	2

ASSEMBLY

Step 1 — Determine which face of the plywood (**A**) is least smooth, and consider that the bottom face. On the bottom face, locate, clamp, and screw on the stiffeners (**D**) (about every 18 inches). Be sure screw head tops are flush. Sand any splinters.

Step 2 — On the top face of the plywood, locate, clamp, and screw on the border walls (**B,C**) around the top perimeter. The wall-to-wall dimensions must measure $93\pm 1/8"$ by $45\pm 1/8"$ ($2362\pm 3\text{mm}$ by $1143\pm 3\text{mm}$), and the height of the height of **B** and **C** must measure $3\pm 1/2"$ ($77\pm 13\text{mm}$), with all border walls being the same height as each other.

Step 3 — With the help of another person, place this table top on short saw horses (or milk crates, or anything else short and solid).

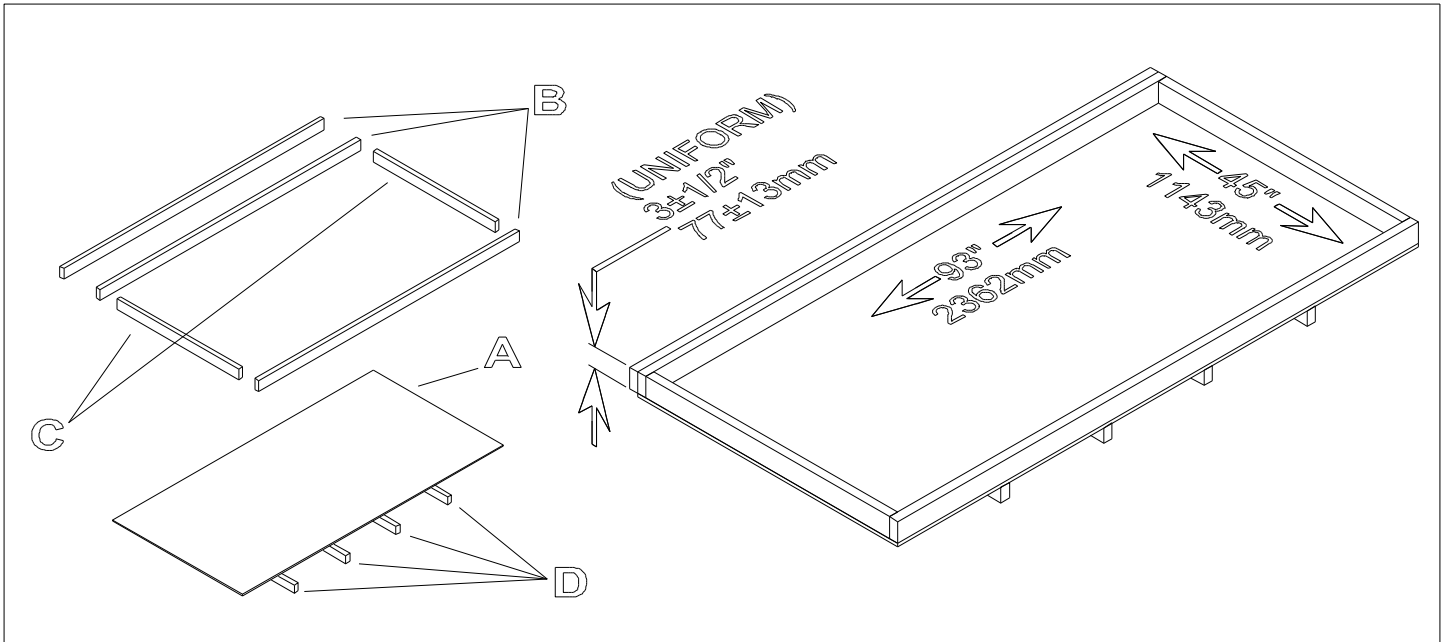

FIELD MAT PLACEMENT

Step 1 — Vacuum the table top. Even the tiniest particle under the mat can give the robot trouble. After vacuuming, run your hand over the surface and sand or file down any protruding imperfections you find. Then vacuum again.

Step 2 — On the vacuumed surface (never unroll the mat in an area where it could pick up particles), unroll the mat so the image is up and its north edge is near the north/double border wall (note the location of the double wall in each table sketch below).

Step 3 — The mat is smaller than the playing surface by design. Slide and align it so that there is no gap between the south edge of the mat and the south border wall. Center the mat in the east-west direction (look for equal gaps at left and right).

Step 4 — With help from others, pull the mat at opposite ends and massage out any waviness away from the center and re-check the requirement of Step 3. It is expected that some waviness will persist, but that should relax over time. Some teams use a hair dryer to speed the relaxation of the waviness.

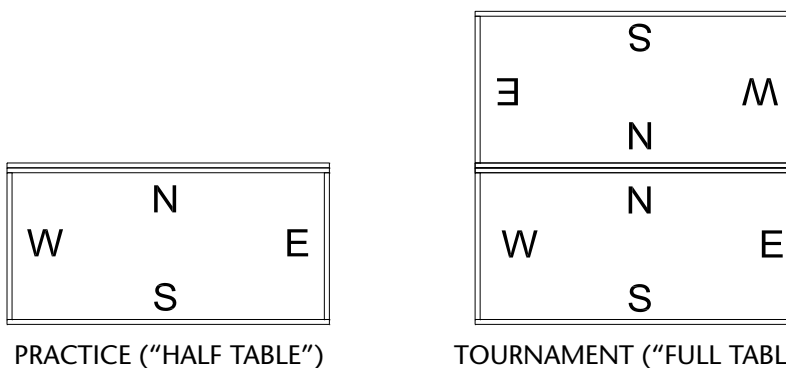

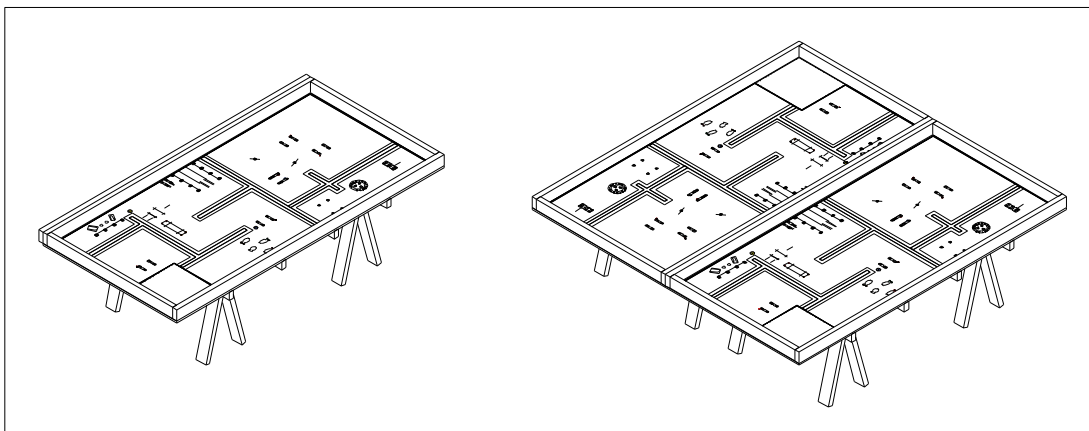

MISSION MODEL CONSTRUCTION

Build the mission models — Use the LEGO elements and instruction CD from your Field Setup Kit. It should take a single person between two and four hours to do this, so it's best done in a work party. For any team members with little or no experience building with LEGO elements, mission model construction is a great way to learn. This step is also a nice time for new team members to get acquainted with each other.

MISSION MODEL ARRANGEMENT AND SETUP

DUAL LOCK

For models where “Dual Lock Needed” appears in the mission model details below, that means the model needs to be secured to the mat during use. The connection is made using the re-usable fastening material from 3M called Dual Lock, which comes in the flat clear bag with the LEGO elements in your Field Setup Kit. Dual Lock is designed to stick or “lock” to itself when two faces of it are pressed together, but you can unlock it too, for ease of transport and storage. The application process for the Dual Lock is only needed once. Later, the models can simply be locked onto the mat or unlocked. To apply Dual Lock:

Step 1 — Stick one square, adhesive side down, on each box you see on the mat with an “X” in it.

Step 2 — Press a second square on top of each of those, “Locking” them on, adhesive side up.

TIP: Instead of using your finger, use a bit of the wax paper the squares came on.

Step 3 — Lower the model onto the squares.

CAUTION — Be sure to place each square precisely on its box, and each model precisely over its marks.

CAUTION — When pressing a model down, press down on its lowest solid structure instead of crushing the whole model. Pull on that same structure if later you need to separate the model from the mat.

TIP: For large and/or flexible models, apply only one or two sets at a time.

DUAL-LOCKED MODELS

Handwash Station (Sink) – See pictures & mat marks.

Fences – One is in the northwest corner, facing south. The remaining two are in the north center, one to the left of the dock, and one to the right. The right fence faces west, and the left one faces east.

Table & Flowers/Centerpiece – See pictures & mat marks.

Timer – See pictures & mat marks.

Thermometer – See pictures & mat marks.

Interactive Models (Rat Slides) – For the east slide, see pictures and mat marks. This model is Dual-Locked to the north border wall as well as to the mat. Dual Lock it to the mat, a coin's thickness from the wall (depending on the exact size of your mat and table, the Dual Lock might not go exactly on its marks – that's okay). Then, add Dual Lock between the model and the wall, as shown. You need to place the second model on the back side of the (double) north wall, diagonal from the first model. Center it on the big black line. Use as much Dual Lock as needed to get it to stick the wall, since there's no actual table back there to hold it.

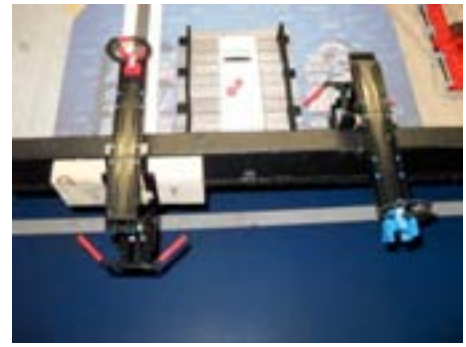
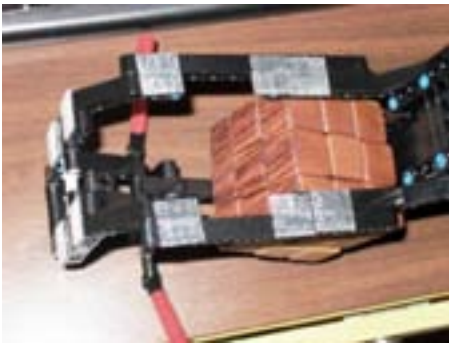

Contamination Risks (Dispensers) – Before securing these, move two beams on each as follows:

- Step 1** – Take the long beam off the outside of its base.
- Step 2** – Remove the black pin nearest the end of the base.
- Step 3** – Insert the pin one hole from where you took it out (even though the beam itself is moving two holes).
- Step 4** – Put the beam back on, such that the newly placed black pin goes in the end hole.
- Step 5** – Repeat Steps 1 thru 4 for the other side of the base.
- Step 6** – Place Dual Lock as the mat shows, but also in front of those places, as shown.

The movement of the beam does not change the location of the model. Align the original back of the base over its mark on the mat before pressing down. Also before pressing down, notice that two of these models are mirrored versions of the others, so be sure that the red axle in the model is over a red cross on the mat.



NON-DUAL-LOCKED (LOOSE) MODELS

Farm Animals – See pictures & mat marks. Be careful – one of the chickens is a complete lunatic.

Bacteria & Virus (Germs) – Bacteria go in the dispensers in the quantities and locations shown, except all yellow go in Base, and two red go in the refrigerated trailer. Eight virus go with the greens and eight with the pinks.

Poison (Blue & Yellow Balls) – See pictures & mat marks. Refrigeration Trailer – The back of the white refrigeration trailer is pushed against the north border wall, between the two center fences, centered on its marks.

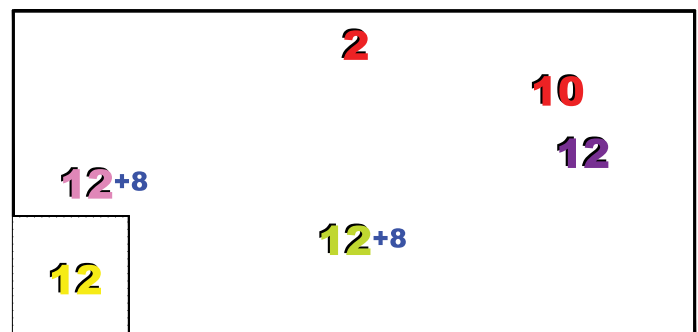

Food (Groceries) – There are twelve units of groceries: Ten in Base, and two specific ones in the yellow truck.

Meat & Fish – The crate of meat goes in Base, and the fish go exactly on their marks east of Base.

Harvester & Corn – See pictures and mat marks. Put the harvester on the west-side ship, facing east, and roll it backward slowly until it resists. Now pick it up without letting the rear wheels spin. Load the four pieces of corn into the back. All four pieces must be individually loose. Now carefully position the harvester over its mark and set it down. TIP: To reduce the chance of corn being stuck in the harvester, every time you load the corn, gently apply some spreading force between the walls to open the gap a little bit. The required spread is so small, you can't tell the difference by eye.

Pickup (Yellow Farm Truck) – Only the bananas, tomatoes, and carrots, in two cases, sit flat in the bed of the truck.

Loops (Pizza & Ice Cream) – Be sure the loops are evenly shaped and not leaning.

Rats – Place the rat loops on their respective slides in the north center. The rats can face randomly north or south, and are pushed as far as they can go toward the color end of their slides. Be sure the loops are evenly shaped and not leaning.



West Side

East Side



PRACTICE FIELD



FIELD MAINTENANCE

- **Border Walls** — Remove any obvious splinters, and cover any obvious holes.
- **Field Mat** — Make sure the mat touches the south border wall, and is centered east to west. Avoid cleaning the mat with anything that will leave a residue. Any residue, sticky or slippery, will affect the robot's performance compared to a new mat (many tournaments use new mats). Use a vacuum and/or damp cloth for dust and debris (above and below the mat). To get marks off, try a white-plastic pencil eraser. When moving the mat for transport and storage, be sure not to let it bend into a sharp kink point, which could affect the robot's movement. Tournaments using new mats should unroll the mats as far in advance of the tournament day as possible. For control of extreme curl at the east or west edges of the mat, tape is allowed, with a maximum of ¼" (6 mm) overlap. Foam tape is not allowed.
- **Mission Models** — Keep the models in original condition by straightening and tightening solid connections often. Ensure that spinning axles spin freely by checking for end-to-end play and replacing any that are bent.

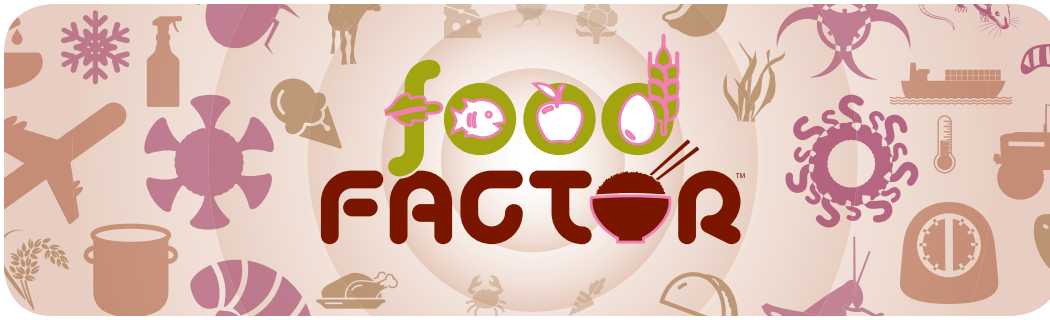

2011 FLL CHALLENGE

robot game — missions

KEEP IN MIND: If a race were held in late 1903, between the original Ford “Model A” automobile and the Wright brothers’ first airplane, it would have been close — but a horse would have beaten them both. If the contest were about transportation value, the plane, with its barely controllable 120-foot flight, would again have been beaten by both the car and the horse. Although that plane had less speed and controllability than a horse, it was immediately obvious that the astonishing engineering innovation and raw potential present in its design would bring travel to previously inconceivable heights. Keep this in mind as you develop your robot. The full FLL robot development experience is only partly about tournament-day game points. In FLL, a crazy fun design that sometimes works is just as good as a dull design that always works. As far as the technical judges are concerned, it really is the **THOUGHT** that counts!

THEME

Don’t be scared, but do be aware... Do you have any idea how many ingredients are in food, how many places those ingredients come from, and how many steps each one has gone through before you eat it? The count is so large and confusing, that almost no one can keep track. And almost every step along the path for every ingredient is a chance for contamination.

Every ingredient has origins either in the ground, the water, or a chemical plant, and most come from other states or countries. Most ingredients are exposed to air. Most are worked on by people and machines, stored in different places, for different times, at different temperatures. Most are shipped, combined, processed, and packaged. Eventually they’re prepared and served. Many are held by **YOUR HANDS!**

For the Food Factor Robot Game, your robot’s job is to put some common foods through just a few of the steps they go through in order to get into your belly, while either avoiding or dealing with contamination.

MISSIONS

MISSION: Read the [Rules](#) page, [Field Setup](#) page, and the [Updates](#) page. Please!

Knowledge Is Power.

MISSION: POLLUTION REVERSAL — No matter where pollution originates, it usually finds its way into water. And of course, all plants and animals take in water. Since we depend on plants and animals for our food, pollution is a source of contamination, not just in what we breathe and drink – but also in what we eat. The yellow and blue balls represent pesticides on the farm and heavy metals in the water. While on their rings, they’re off the mat.

SCORING CONDITION(S): Balls touching the mat are worth 4 POINTS EACH.

MISSION: CORN HARVEST — A harvester (combine) is just one of the many huge pieces of machinery that handle massive amounts of food at once. Equipment like this runs on gasoline, and has oil. You can also find hydraulic fluid, nuts & bolts, screens, gaskets, set screws, bearings, sealant, paint chips, and bugs on it – any of these materials and substances could find their way into the food.

SCORING CONDITION(S): Get points for one of these only:

---ANY piece of corn touching the mat is worth 5 POINTS (additional pieces do not add to your score).

-----OR-----

---ANY piece of corn in Base is worth 9 POINTS (additional pieces do not add to your score).

MISSION: FISHING – Fish must be eaten or frozen immediately after being caught. The number of germs that depend on fish is much, much higher than the number of people who do!

SCORING CONDITION(S): Big fish in Base are worth 3 POINTS EACH, if the baby fish is still touching its mark.

MISSION: PIZZA AND ICE CREAM – When you go out in public to eat, you place a lot of trust in the people preparing your food. Do they wash their hands or wear fresh gloves? In what direction do they sneeze? How clean are their storage and preparation areas? At what temperatures are the foods stored and cooked? How old are the ingredients? How are pests controlled?

SCORING CONDITION(S): Pizza and ice cream in Base are worth 7 POINTS EACH.

MISSION: FARM FRESH PRODUCE – In general, the fresher your food is and the fewer ingredients there are in it, the less chance it has had to become contaminated. Small farms and fisheries close to where you live are a good source of fresh food, but many small farms don't get the same level of inspection as large ones do.

SCORING CONDITION(S): The yellow farm truck in Base is worth 9 POINTS.

MISSION: DISTANT TRAVEL – Your body suppresses and eliminates the vast majority of chemicals and germs you eat, and it's especially good at getting rid of stuff it's been exposed to before – stuff it's used to. But when you eat in a city or country that's very far from home, your body's defenses can be caught off guard by contaminants it's never processed before. It's common for travellers to get quite sick after eating certain foods, while other people who ate the same foods right next to them have no problems.

SCORING CONDITION(S): The robot touching the east wall is worth 9 POINTS. Remember Rule 23.

MISSION: COOKING TIME – Before cooking, some foods have more germs, or tougher germs than others. If you're supposed to cook a food for 40 minutes, but you think "it should be okay" after 35 – think again!

SCORING CONDITION(S): The white pointer in the red zone is worth 14 POINTS.

MISSION: STORAGE TEMPERATURE – Germs grow fast. If your refrigerator is set even a few degrees higher than it's supposed to be, the "shelf life" of many of the foods is cut in half, or even further. If you go to play ball instead of helping to put the picnic food back in the cooler – that's bad! If you ever hear the phrase "it's only been out for a few hours" –make some noise!

SCORING CONDITION(S): The thermometer spindle clicked/dropped fully showing the low red temperature is worth 20 POINTS (the spindle needs to drop all the way).

MISSION: PEST REMOVAL – Some animals carry many, many germs that don't bother them, but which are really bad for us. And some animals have extremely unclean habits (enough said about that!). These animals have become very good at infesting population centers and especially food storage, shipping, and preparation areas, living in the shadows, climbing and nesting in the tiniest unseen places. Convince them to live somewhere else! Keep all food well-sealed, and all food areas clean. At the first sign of these pests, it's usually too late!

SCORING CONDITION(S): Rats in your Base are worth 15 POINTS EACH (to you only).

MISSION: REFRIGERATED GROUND TRANSPORT – In shipping, cases of frozen and refrigerated foods are often thrown onto pallets, spilled, torn, and crushed by forklifts, and each other, as they are warehoused and loaded onto trucks bound for the marketplace. Then the cases go on bumpy rides for hours in the sun. Amazingly, only a tiny percentage of the food gets contaminated during all this. The problem is, this tiny percentage totals tens of thousands of tons a year! And while most of that is discovered and thrown away, "some" is not.

SCORING CONDITION(S): Get points for one of these only...

---The trailer in Base is worth 12 POINTS.

-----OR-----

---The trailer with meat inside, and no germs inside, with any of its wheels touching the port dock north of the white line is worth 20 POINTS, and 6 ADDITIONAL POINTS for each big fish inside. For fish points, the baby fish must still be touching its mark.

MISSION: GROCERIES – Here’s your chance to buy undamaged goods, as fresh as possible, with the fewest ingredients possible, from trustable places, and get your cold stuff home and put away as soon as possible!

SCORING CONDITION(S): EACH grocery unit is worth 2 POINTS if the table is supporting all of its weight, and no weight other than grocery units (the flower centerpiece can be there too).

MISSION: DISINFECT – It would be very tough to eliminate food contamination from all sources, but you can probably do more than you think, and if you can at least avoid making it worse, that would be a great start.

SCORING CONDITION(S): Empty dispensers are worth

---12 POINTS EACH, if NO bacteria is touching the mat outside Base.

-----OR-----

---7 POINTS EACH, if ANY bacteria is touching the mat outside Base.

MISSION: HAND WASH/BACTERIAL – Innovative ideas in the future may help us reduce germs, chemicals, and particles, in natural, farming, processing, and public food settings, but studies have shown that one of the biggest source of contamination to your food is your own hands. So wash them! Front and back, with soap, in hot water, for three times longer than you do now! As this mission should show, you can never wash your hands enough.

SCORING CONDITION(S): Bacteria in or on the sink are worth 3 POINTS, only if all of these are true:

---All were in Base at some time prior to being in the sink.

---While between Base and the sink, each was the only one in motion.

---All equipment involved with each bacterium’s trip to the sink was

--completely in Base at the beginning of the trip.

--completely out of Base at the end of the trip.

---The sink is supporting all the weight of every germ, and not supporting any weight except germs.

Bacteria getting to the sink any other way are given back to the team in Base by the referee (the “ref”).

MISSION: HAND WASH/VIRAL – Viruses almost always need a “host” (another living thing) to live on. They are almost always bad, and they’re also somewhat harder to deal with than bacterial germs. Alcohol sanitizer, bleach sanitizer, and high heat are the better weapons against viral germs, but hand washing is also helpful.

SCORING CONDITION(S): Get points for one of these only...

---One to eight viral germs in the sink are worth exactly 6 POINTS only.

-----OR-----

---Nine or more viral germs in the sink are worth exactly 13 POINTS only.

MISSION: GOOD BACTERIA – Not all bacteria are bad. There are about a thousand types of good bacteria living on/ in your body, which total in the tens of trillions! Bacteria do all sorts of good work for you, and help process your food, both before and after you eat it. How do we get rid of bad bacteria without upsetting the good bacteria? Bacteria are this year’s “touch penalty objects” as described in the Rules. When you cause a touch penalty, the ref takes one yellow bacterium.

SCORING CONDITION(S): Yellow bacteria are worth 6 POINTS EACH in Base only.



2011 FLL CHALLENGE

robot game — rules, procedures, philosophies and definitions

1 — GRACIOUS PROFESSIONALISM™

- You are “Gracious Professionals.” You are competing hard against PROBLEMS, while treating PEOPLE with respect and kindness — people from your own team, as well people from other teams.
- You build onto other people’s ideas instead of resisting or defeating them.

2 — PARTICIPATION

- The maximum allowable team size is ten members, not including coaches and mentors.
- See the *FIRST LEGO League Coaches’ Handbook* for allowable ages.
- At the tournament, only TWO team members at a time are allowed right up at the competition table except during repair emergencies.
- The rest of the team must stay back from the table, but close enough for different members to tag in or out as desired at any time. Specific positioning is decided by the tournament officials.

3 – INTERPRETATION

- Robot game text means exactly and only what it says, so it should be taken literally whenever possible.
- Do not interpret text based on your assumption about intent, or on how a situation might be in “real life.”
— Example: If a mission is to “enter the house,” the window is just as valid an entry point as the door.
- If a detail isn’t mentioned, then it doesn’t matter.
— Example: If a mission is to “put the cup on the table,” upside down is just as valid as right side up.
- There are no hidden requirements or restrictions, but there are hidden freedoms, and you’re encouraged to find them!

4 — EQUIPMENT

Your robot, attachments, and other accessories must be made entirely of LEGO-manufactured elements in original factory condition. Stickers are not allowed, except LEGO stickers, applied per LEGO instructions. Paint, tape, glue, oil, etc. are not allowed.

- Exception 1: You may reference a paper list to keep track of robot programs.
- Exception 2: LEGO string and tubing may be cut to length.
- Exception 3: Marker may be used for ownership identification, for marks in hidden areas only.

REGULAR ELEMENTS

- You may use as many non-electric LEGO elements as you like, including pneumatics, and they may be from any source or set. Exception: Factory-made wind-up/pull-back “motors” are not allowed.

ELECTRIC ELEMENTS

- You are allowed a maximum of six non-rotation sensors in the competition area. Choose your favorite combination from among the LEGO-manufactured Mindstorms touch sensors, light sensors, color sensors, and ultrasonic sensors.
- You are allowed a maximum of three MINDSTORMS™ motors in the competition area.
- These quantity limits don't just apply to what's on your robot "right now." The referee (the "ref") adds up everything you have with you in your boxes, your hands, your trays, and on the table too. All of it counts towards your total.
 - Example: If you have multiple motorized attachments, but it takes two motors to drive the robot, you must find a way to switch that third/last legal motor from one attachment to the next.
 - A fourth motor in the competition area is always illegal, no matter what.
 - Even if you plan to run only three motors at a time, the fourth motor is illegal.
 - Even if the fourth motor is a spare, or used as weight, or as decoration, the fourth motor is illegal.
- "RCX" robots are allowed, with a max of eight sensors from among touch, rotation, and light.
- You may not use more than one robot in any one match, but it's okay to use a different robot in a different match.
- LEGO wires and converter cables are allowed as needed.
- No other electric elements nor devices are allowed for use in any way in the competition area.
- Spare electrical parts are allowed in the PIT area.
- Objects functioning as remote controls are not allowed anywhere, any time.

NON-ROBOT EQUIPMENT

- Your equipment may include LEGO elements or devices other than the robot and its attachments.
 - Example 1: You may use a gauge to help set a feature on your robot in Base.
 - Example 2: The robot may carry a ramp out to help itself cross a barrier.
- If outside Base, such "strategic objects" are left wherever the robot leaves them.

SOFTWARE

- The robot may only be programmed using LEGO MINDSTORMS, RoboLab, or NXT-G software (any release). No other software is allowed.
- Patches, add-ons, and new versions of the allowable software from the manufacturers (LEGO and National Instruments) are allowed, but tool kits, including the LabVIEW tool kit, are not allowed.

If the robot is in violation of this rule and cannot be corrected, the decision about exactly what to do rests with the tournament officials, but it is possible the team may not be eligible for awards.

5 — MISSION

A mission is one or more achievable objectives/results worth points, as detailed on the "Missions" page.

- You decide the order in which to try the missions, and how many to try with each program on the robot.
- You may re-try missions when that's possible, but the field is not reset for that purpose. Example: If a mission is for the robot to topple a stack eastward, and the robot doesn't reach it, you could try again later, since the stack is undisturbed. But if the active robot topples the stack westward, the mission is impossible to re-try, and does not get reset.

6 — MATCH

At a tournament, two robot game fields are joined back to back, and you are paired opposite another team to compete in a match. There are at least three matches. Each match lasts 2-1/2 minutes. Here's the process:

- You get to the competition table and have at least one minute to prepare your equipment.
- The match starts and you start the robot from Base. Once started, the robot is "active" and is understood to be working "autonomously" on missions, under its own power and programming, allowed to grow to any size and go anywhere it wants.

- The robot might get a lot done, or a little, but eventually you are likely to need/want to handle it. For example, it might get stuck, or you might want to add an attachment or unload some cargo.
- If you do decide to touch the robot while it's active, no matter where it is or what it's doing, that makes it "inactive," and it must immediately be carried to Base if it's not already there.
- While the inactive robot is in Base, you prepare it for its next active period, and restart it.
- These steps repeat (often with music, an announcer, and cheering in the background!) until the match end signal sounds. The timer never pauses during a match.
- You play at least three matches a tournament, each one being a fresh chance for you to get your best score.
- No match has anything to do with another, and only your best score counts specifically toward the Robot Performance Award. Exceptions: playoff matches and tie-breakers.
- If it is known in advance that you will not have another team opposite you, a volunteer or "house" team substitutes. If not, and you compete against an empty table, you get the points for any missions that would have involved the missing team.
- After the match, no one is allowed to touch anything on the field until the ref has recorded the condition of the field and come to agreement with you (kids only) about what points were scored or missed and why.
- Data is marked on a sheet which you initial, making the sheet final.
- The scores are tallied by computer, with ties being broken using 2nd, then 3rd highest scores.
- In the rare occasion of a tie across all three matches, tournament officials decide what to do. Options include a variety of playoffs, or simply awarding multiple same-place awards.

7 — ROUND

The process of cycling all teams through one match each is called a round.

8 — BASE

Base is an imaginary box formed by vertical walls that rise from the perimeter of the Base area, including the inside surface of the border walls, and by an invisible ceiling 16 in (40 cm) high.

- This means Base is not just an area on the mat – it's a VOLUME.
- Usually there is a gap between the mat and a side border wall... Base includes this gap.
- Anything in the team's possession is understood to count as being in Base, and is okay to store or handle.

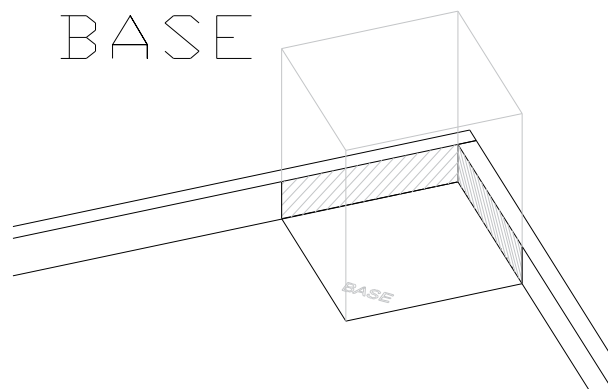

9 — FIELD

The field is where the robot game takes place. It consists of mission models on a field mat on a table.

- The field mat and the LEGO elements for building the mission models are part of your Field Setup Kit.
- The instructions for building the mission models are on a CD which comes in the same box as the LEGO elements and mat.
- All other field setup instructions are on the Field Setup page.

10 — MISSION MODELS

Mission models are the objects that are already on the field when you walk up to it.

- You may not bring duplicate mission models to the table if they could confuse scoring.
- You may not take mission models apart, even temporarily.
- You may not add to nor trap mission models as to cause a failure of the "gravity test."

- GRAVITY TEST — Any time you (by HAND) make an individual mission model touch, trap, or be trapped by ANY other object (including the robot, other team-supplied parts, and other models) — Gravity alone should be able to separate them if the heavier were picked up and/or turned over.
 - In the case of identical models, it doesn't matter which is picked up.
 - The team performs this "gravity test," only if asked by the ref, and only when failure looks probable.
 - The ref does not allow a start unless all mission models could pass the gravity test.
 - Only if there is no hand-help at all, the ROBOT is allowed to cause models to fail the gravity test.
- Don't walk away with mission models from the competition area. Bring them back if you do. Thanks.

11 — CARGO

Cargo is anything the robot has with it for transport or release.

12 – AUTONOMY

The robot game is played by an "autonomous" robot.

- That means the robot must do its work without any influence/help from you while it's working. You PREPARE the robot, but it PERFORMS on its own.
- The robot may PERFORM ANYWHERE, but it may only be PREPARED in BASE.
- Any time you touch it, it is assumed to need your help and preparation, so it must be carried to Base.
- If this was planned, and the robot and its cargo are already in Base, no problem. However, touching the robot while it, or its cargo is outside Base is seen as a rescue, so there can be penalties.

13 — ACTIVE ROBOT <> INACTIVE ROBOT

- The moment the robot is started, it becomes "ACTIVE," and remains so until the next time you touch/influence it.
- At the moment of that touch, the robot becomes "INACTIVE," and is hand-prepared for restart from Base.

14 – HANDLING (MISCELLANEOUS)

Calibration – During your pre-match setup time only, you may calibrate light & color sensors outside Base.

Quality Control – During your pre-match setup time only, you may ask the ref to double-check that a particular setup is correct/within spec, but you may not request any custom setup, in or out of the range specified in the setup instructions.

Changing Things Outside Base — You may not hand-place, extend, roll, topple, drop, throw, eject, slide, or shoot things outside Base, even partly. You may not hand-change the position, motion, quantity, or other status of things outside Base. Only the robot may make changes outside Base, including the addition and removal of objects. See exceptions in the "Touch Penalties," "Storage And Workspace," and "Failure And Loss" rules.

Illegal Changes – If you or your robot cause illegal changes to the field other than mission model destruction, either by accident or on purpose, the action is "undone" as quickly and accurately as possible---if possible. But if the pre-change condition is unknown, or the changes are too confusing or severe to undo, the changes are left as is. Obviously, previous accomplishments can be ruined because of this, but intended missions can be ruined too, and missions that obviously benefit from such destruction are marked scoreless.

Mission Model Destruction – If you or the robot damage a mission model or defeat its Dual Lock connection, by accident or not, the situation is left as-is. Obviously, previous accomplishments can be ruined because of this, but intended missions can be ruined too, and missions that obviously benefit from such destruction are marked scoreless.

Inactive Robot Handling – During setup, and whenever else the robot is inactive, you may repair it, aim it, switch attachments, select programs, reset features, and load/unload cargo in Base, or wherever your equipment is stored.

Separated/Stored Objects — You may at any time, in Base, or wherever your equipment is stored, handle things the robot is not currently touching or using, except as described in the “Start/Restart Procedure” rule.

Aiming – You may use a device to aim the robot, but its use must be completely in Base at all times, and you must let go of it prior to starting/restarting.

Staging – You are allowed to place objects in the robot’s path, completely in Base only.

Chain Reactions — If moving the robot by hand outside Base will unavoidably allow/cause the movement of any non-cargo object, such as something being “held up” or “held back,” the movement of that retained object (the chain reaction) must be kept to an absolute minimum. Allow the stored energy to dissipate slowly over as little distance as possible.

Strategic Rescue — Stopping the robot during a strategically precise window of opportunity for progress toward a mission task is illegal and causes related missions to be marked scoreless.

Broken Robot — You may at any time recover pieces of an obviously broken robot.

15 – STORAGE AND WORKSPACE

- Once the ref inspects your equipment, you may store things as needed in Base, or in a box, or by hand, or possibly on a stand, if stands are allowed at your event (decided by your tournament’s officials – check with them in advance).
- If you feel crowded in Base, storage and handling of the robot and other objects may extend over Base lines, as long as there is absolutely nothing strategic about this temporary spillover.
- Mission models and objects worth points in Base always need to stay in view of the ref.
- Nothing is allowed on the floor.

16 – START/RESTART POSITION

- For the match start and all restarts, EVERY BIT of the robot, including its installed attachments & wires, everything touching it, and any objects it is about to move or use, must ALL fit COMPLETELY in Base.
- The ROBOT MAY be touching objects it is about to move or use.
- YOU may NOT be touching objects the robot is about to move or use.
- YOU may NOT be touching objects the robot is touching.
- Everything must be motionless.
- All mission models in Base must be able to pass the gravity test.

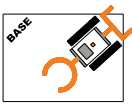
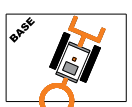
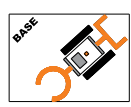
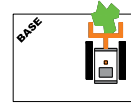
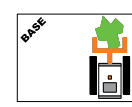
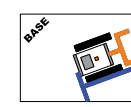
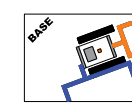
START POSITION						
						
NO	NO	YES	NO	YES	NO	YES

17 – START/RESTART PROCEDURE

- When it’s obvious to the ref that starting position is correct:
- For the first start of the match:
 - The ref asks you if you’re ready, then signals your readiness to the announcer.
 - As the countdown starts, you reach in with one hand, ready to either touch a button, or signal a sensor, to start or resume the robot’s program.
 - When you hear the sound, you start the robot. The exact time to start is at the beginning of the last word in the countdown, such as “Ready, set, GO!”

- If a non-word signal is used, like a beep or buzzer, the start is at the beginning of that signal.

— For all other starts in the same match (restarts):

- There's no countdown. The ref sees that start position is correct, and you start the robot.

- You may not handle the robot, or anything it's about to move or use, during the countdown, except for the single action needed to get the program running. If you do, the ref has you restart.

18 — TOUCH PENALTIES (THIS RULE IS ABOUT WHAT HAPPENS WHEN YOU TOUCH THE ROBOT)

- If you touch the active robot or anything it's touching while the ROBOT is completely outside Base, you lose one "touch penalty object" (identified in the Missions).
- If you touch the active robot or anything it's touching while its CARGO is completely out of Base:
 - if the cargo was with the robot the last time the robot left Base, it goes to Base.
 - if the cargo was NOT with the robot the last time the robot left Base, the ref takes it away.
- Warning: Avoid touching a robot entering Base until its cargo has also reached Base!

If the only part of the robot in Base at the time of the touch is a cord, hose, wire, tube, chain, string, or other feature obviously used purely for extension, the robot is treated as if it were outside Base.

19 – FAILURE AND LOSS (THIS RULE HAS NOTHING TO DO WITH YOU TOUCHING THE ROBOT)

- Anything done to your field outside Base by your legally active ROBOT stays that way, unless the ROBOT changes it.
- Objects moved are not replaced or moved out of the way by hand.
- Objects damaged are not repaired or reset by hand.
- Cargo the robot loses contact with, is left wherever it comes to rest (if it goes off the table, the ref keeps it).
- This means the robot can ruin its own opportunity to accomplish tasks, and it can even spoil previous results.

Exception: Parts not designed to separate from the robot, but which separate due to obviously accidental DAMAGE may be recovered by YOU, by hand, at any time – even if they have cargo (gift: you keep any cargo in question).

20 — INTERFERENCE

- Your robot may not have any effect on the other team's robot, field, or strategy except near the model(s) shared between both teams, where accidental interference is expected and acceptable.
- If Robot X deliberately blocks or un-scores Robot Y's progress/results, Robot X's mission(s) in that area are marked no score, and Robot Y's are marked as complete.
- If two robots become entangled, they are both allowed to restart without penalty. Any cargo involved is given to the team in Base, whether or not it has ever been there before.
- As a matter of luck, the other team might out-perform you in a competitive interactive mission, or might fail to help you in a cooperative interactive mission. The net effect is the same, and this is not considered interference.

21 – IN

- **A** is "in," "into," or has "reached" **B** if ANY BIT of **A** is OVER **B**.
- To be "in" an area is to penetrate the volume over that area.
- Barely "in" is considered "in" unless "completely in" is required.
- **A** can be "in" **B** without touching **B**.
- Objects are ruled on independent of each other, and independent of their transports/containers.

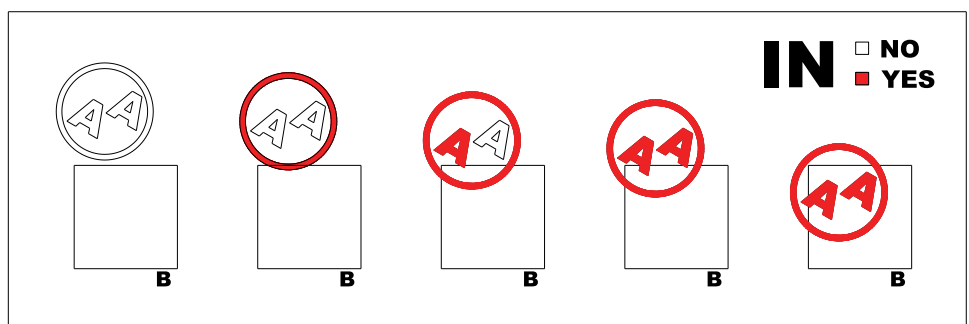

22 – TOUCHING

- **A** is “touching” **B** only if **A** is making direct contact with **B**. Exception: If **B** were your hand, the 1st example would get a YES, since even an indirect touch from your hand is considered a touch.
- Any amount of direct contact counts as touching.

23 – SCORING

With rare exception, your score is assessed **based on the conditions at the exact time the match ends only**.

- Points are not given for results the robot produces during the match but then trashes before the end.
- Points are not given nor taken away for results produced after the match end signal ends.

24 — AFTER THE MATCH

No one is allowed to touch anything on the field yet:

- The ref first needs time to record the condition of the field, and come to agreement with you (kids only) about what points were scored or missed and why (and to be sure you’re not walking away with any of that field’s mission models!). Data is marked on a sheet which you initial, making the sheet final.
- The scores are tallied by computer, with ties being broken using 2nd, then 3rd highest scores. If more than one team gets a perfect score in all regular rounds, tournament officials decide what to do. Options include a variety of playoffs, or simply awarding multiple same-place awards.

25 — BENEFIT OF THE DOUBT

You get the benefit of the doubt when:

- a split-second or the thickness of a (thin) line is a factor.
- a situation could “go either way” due to confusing, conflicting, or missing information.
- a ref is tempted to rule based on the “intent” of a requirement or constraint.
- no one’s really sure WHAT just happened!

If you (kids, not coach) disagree with the ref and can respectfully raise sufficient doubt in his/her mind during your post-match chat, your ref meets with the head ref, and the resultant decision is final. This rule is not an order for the refs to be lenient, but for them to rule in your favor when they’ve done all they can to rule correctly, yet the answer’s still unclear.

26 — DOWNLOADING

- Downloading programs to robots may take place in the pits only — never in the competition area.
- Always download by cable. Bluetooth must be switched off at all times.

27 — VARIABILITY

As you build and program, keep in mind that our suppliers, donors, and volunteers make every effort to ensure that all fields are correct and identical, but you should always expect some variability, such as:

- flaws in the border walls.
- variety in lighting conditions, from hour to hour, and/or table to table.
- texture/bumps under the mat.
- presence or absence of tape at the East and West edges of the mat.
- waviness in the mat itself. At many tournaments, it is impossible for the mats to be rolled out in time to lose their waviness. Location and severity of waviness varies. You are being warned here. Consider this while designing.
- Two important building techniques you can use to limit the effects of variability are:
- Avoid steering systems that involve something sliding on the mat or border walls.

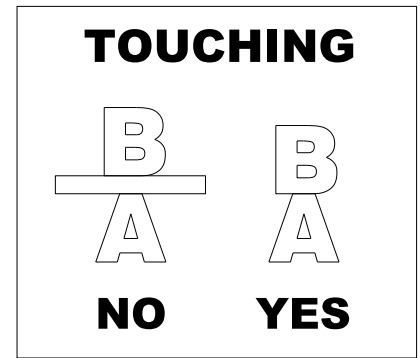

- Cover your light sensors from surrounding light.
- Questions about conditions at a particular tournament should only be directed to that tournament's officials.

28 — PRECEDENCE/AUTHORITY

- You get information about the robot game from more than one place. Once in a while, information from different places conflicts. So here is the order of precedence for the sources:
1 = [CURRENT Robot Game Updates](#), 2 = [Missions and Field Setup](#), 3 = [Rules](#)
- If something on a page conflicts with something else on the same page, the most sensible interpretation is assumed. If two interpretations seem equal, the interpretation most favorable for the team is assumed.
- On all pages, videos and pictures are for guidance and example only. Often they can not express complete information, and are therefore misleading. When there is conflict between pictures/videos and text, the text takes precedence!
- The head ref at a tournament is required to base decisions on the information above, in the order shown above. No other source of information is official, including e-mails from Robot Game Support.

29 — ROBOT GAME SUPPORT

Professional/expert robot game support is available directly from the designer/author (Scott) at fillrobotgame@usfirst.org (usual response in 1-2 business days).

- When e-mailing, please state your role in FLL (member, coach, parent, mentor, referee).
- You'll get a reply with personalized guidance constructing documentation-based paths of logic/reason for assessing special strategies or situations in terms of legality and scoring.
- The ref is not obligated to read individual response e-mails, but your case might prompt a posting on the Robot Game Updates page if it's popular, reveals missing or confusing text, reveals a flaw in the game, reveals an unresolvable conflict, or is so innovative, it blows everybody away.
- No new [Robot Game Updates](#) are posted after 3PM (eastern U.S.) on Fridays.
- You won't get help/advice about building or programming (that's your challenge).
- Questions about LEGO product in general get redirected: Instead call (U.S.) 1-866-349-LEGO.
- Questions posted in the discussion forum are not seen nor responded to by Robot Game Support.

WARNING: The forum is great for sharing ideas and getting tips from [other teams](#), but it is not an official source of answers about anything.

30 — COACHES' MEETING

- If a question does come up right before the tournament, your last chance to ask it is at the "Coaches' Meeting" (if there is one) the morning of the tournament.
- The head ref and coaches meet to identify and settle any differences BEFORE the first match.
- For the rest of the day, the ref's calls are final when you leave the table.

CHANGES OF NOTE FOR 2011

- The limits on sensors have been changed from type and quantity to quantity only.
- Team members not at the table may now hold equipment after inspection.