

# CML Tape and Reel Specification

Publication: D/TandR/5 May 2007

This document defines the Tape and Reel specifications available from CML.



**Note:**

1. This specification is for use by the customer and is intended for publication on the website or data book
2. It does not imply any changes to the working specification.

|                                                       |   |
|-------------------------------------------------------|---|
| 1. Scope .....                                        | 3 |
| 2. Dimensions.....                                    | 3 |
| 3. Materials.....                                     | 6 |
| 4. Polarity & Orientation of Components in Tape ..... | 6 |
| 5. Fixing of Components in Tape.....                  | 6 |
| 6. Packaging .....                                    | 7 |

## 1. Scope

The specification relates to the tape packaging of integrated circuits suitable for “surface mount” assembly.

It includes only those dimensions that are essential for the purchaser to use this product.

## 2. Dimensions

(Refer to figure 1a & 1b)

### 2.1. Tape Width (W)

|                                                      |     |            |    |
|------------------------------------------------------|-----|------------|----|
| Package style                                        |     |            |    |
| Q5                                                   | W = | 12.0 ± 0.1 | mm |
| D4, D5, D6<br>E1, E2, E3, E4<br>L4<br>Q1, Q2, Q3, Q4 | W = | 16.0 ± 0.1 | mm |
| D1, D2, D3<br>L1, L2, L3, L7, L8, L9<br>M1           | W = | 24.0 ± 0.1 | mm |
| L6                                                   | W = | 32.0 ± 0.3 | mm |

### 2.2. Carrier Tape Thickness (t)

|                    |     |     |    |     |
|--------------------|-----|-----|----|-----|
| All package styles | t = | 0.6 | mm | max |
|--------------------|-----|-----|----|-----|

### 2.3. Pitch of Sprocket Holes (P<sub>0</sub>)

|                    |                  |           |    |
|--------------------|------------------|-----------|----|
| All package styles | P <sub>0</sub> = | 4.0 ± 0.1 | mm |
|--------------------|------------------|-----------|----|

### 2.4. Diameter of Sprocket Holes (D)

|                    |     |                 |    |
|--------------------|-----|-----------------|----|
| All package styles | D = | 1.5 + 0.1 – 0.0 | mm |
|--------------------|-----|-----------------|----|

### 2.5. Distance Sprocket Hole Centre to Tape Edge (E)

|                    |     |            |    |
|--------------------|-----|------------|----|
| All package styles | E = | 1.75 ± 0.1 | mm |
|--------------------|-----|------------|----|

### 2.6. Distance (F)

|               |     |           |    |
|---------------|-----|-----------|----|
| Package style |     |           |    |
| Q5            | F = | 5.5 ± 0.1 | mm |
| D4, D5, D6    | F = | 7.5 ± 0.1 | mm |

E1, E2, E3, E4  
L4  
Q1, Q2, Q3, Q4

D1, D2, D3      F = 11.5 ± 0.1      mm  
L1, L2, L3, L7, L8, L9  
M1

L6      F = 14.2 ± 0.1      mm

## 2.7. Distance between centres if two rows of sprocket holes (S)

Package Style  
L6      S = 28.4 ± 0.1      mm

## 2.8. Distance between oval hole centres (d)

Package Style  
L6      d = 0.2 ± 0.05      mm

## 2.9. Radius of oval holes

Package Style  
L6      r = 0.75      mm

## 2.10. Dimension (P2)

All package styles      P2 = 2.0 ± 0.1      mm

## 2.11. Embossed Pocket Dimensions (A0 & B0)

| Package style | A0                 | B0                 |
|---------------|--------------------|--------------------|
| D1            | A0 = 10.9 ± 0.1 mm | B0 = 18.3 ± 0.1 mm |
| D2            | A0 = 10.9 ± 0.1 mm | B0 = 15.8 ± 0.1 mm |
| D3            | A0 = 10.9 ± 0.1 mm | B0 = 13.2 ± 0.1 mm |
| D4            | A0 = 10.9 ± 0.1 mm | B0 = 10.7 ± 0.1 mm |
| D5            | A0 = 8.2 ± 0.1 mm  | B0 = 8.8 ± 0.1 mm  |
| D6            | A0 = 8.4 ± 0.1 mm  | B0 = 10.7 ± 0.1 mm |
| E1            | A0 = 6.8 ± 0.1 mm  | B0 = 10.2 ± 0.1 mm |
| E2            | A0 = 6.95 ± 0.1 mm | B0 = 8.3 ± 0.1 mm  |
| E3            | A0 = 6.8 ± 0.1 mm  | B0 = 6.9 ± 0.1 mm  |
| E4            | A0 = 6.8 ± 0.1 mm  | B0 = 5.4 ± 0.1 mm  |
| L1            | A0 = 15.8 ± 0.1 mm | B0 = 15.8 ± 0.1 mm |
| L2            | A0 = 11.5 ± 0.1 mm | B0 = 11.5 ± 0.1 mm |
| L3            | A0 = 13.1 ± 0.1 mm | B0 = 13.1 ± 0.1 mm |
| L4            | A0 = 9.3 ± 0.1 mm  | B0 = 9.3 ± 0.1 mm  |
| L6            | A0 = 18.0 ± 0.1 mm |                    |

|    |    |   |            |    |
|----|----|---|------------|----|
|    | B0 | = | 18.0 ± 0.1 | mm |
| L7 | A0 | = | 12.5 ± 0.1 | mm |
|    | B0 | = | 12.5 ± 0.1 | mm |
| L8 | A0 | = | 16.5 ± 0.1 | mm |
|    | B0 | = | 16.5 ± 0.1 | mm |
| L9 | A0 | = | 12.5 ± 0.1 | mm |
|    | B0 | = | 12.5 ± 0.1 | mm |
| M1 | A0 | = | 13.1 ± 0.1 | mm |
|    | B0 | = | 13.1 ± 0.1 | mm |
| Q1 | A0 | = | 9.3 ± 0.1  | mm |
|    | B0 | = | 9.3 ± 0.1  | mm |
| Q2 | A0 | = | 8.3 ± 0.1  | mm |
|    | B0 | = | 8.3 ± 0.1  | mm |
| Q3 | A0 | = | 7.25 ± 0.1 | mm |
|    | B0 | = | 7.25 ± 0.1 | mm |
| Q4 | A0 | = | 6.3 ± 0.1  | mm |
|    | B0 | = | 6.3 ± 0.1  | mm |
| Q5 | A0 | = | 5.25 ± 0.1 | mm |
|    | B0 | = | 5.25 ± 0.1 | mm |

## 2.12. Embossed Tape Dimension (K0)

|               |    |   |           |    |
|---------------|----|---|-----------|----|
| Package style |    |   |           |    |
| D1            | K0 | = | 3.0 ± 0.1 | mm |
| D2            | K0 | = | 3.0 ± 0.1 | mm |
| D3            | K0 | = | 3.0 ± 0.1 | mm |
| D4            | K0 | = | 3.0 ± 0.1 | mm |
| D5            | K0 | = | 2.5 ± 0.1 | mm |
| D6            | K0 | = | 2.4 ± 0.1 | mm |
| E1            | K0 | = | 1.6 ± 0.1 | mm |
| E2            | K0 | = | 1.6 ± 0.1 | mm |
| E3            | K0 | = | 1.6 ± 0.1 | mm |
| E4            | K0 | = | 1.6 ± 0.1 | mm |
| L1            | K0 | = | 2.9 ± 0.1 | mm |
| L2            | K0 | = | 4.1 ± 0.1 | mm |
| L3            | K0 | = | 4.9 ± 0.1 | mm |
| L4            | K0 | = | 2.2 ± 0.1 | mm |
| L6            | K0 | = | 4.9 ± 0.1 | mm |
| L7            | K0 | = | 2.2 ± 0.1 | mm |
| L8            | K0 | = | 1.9 ± 0.1 | mm |
| L9            | K0 | = | 2.2 ± 0.1 | mm |
| M1            | K0 | = | 4.9 ± 0.1 | mm |
| Q1            | K0 | = | 1.1 ± 0.1 | mm |
| Q2            | K0 | = | 1.1 ± 0.1 | mm |
| Q3            | K0 | = | 1.1 ± 0.1 | mm |
| Q4            | K0 | = | 1.1 ± 0.1 | mm |
| Q5            | K0 | = | 1.1 ± 0.1 | mm |

## 2.13. Pitch of Component Pockets (P1)

|                                                   |    |   |           |    |
|---------------------------------------------------|----|---|-----------|----|
| Package style                                     |    |   |           |    |
| E1, E2, E3, E4,<br>Q5                             | P1 | = | 8.0 ± 0.1 | mm |
| D1, D2, D3, D4<br>D5, D6<br>L4,<br>Q1, Q2, Q3, Q4 | P1 | = | 12 ± 0.1  | mm |
| L2, L3, L7, L9<br>M1                              | P1 | = | 16 ± 0.1  | mm |

L1, L8 P1 = 20 ± 0.1 mm

L6 P1 = 24 ± 0.1 mm

## 2.14 Outside Dimension of Pocket (B1)

Package style

|    |                    |
|----|--------------------|
| D1 | B1 = 18.9 ± 0.2 mm |
| D2 | B1 = 16.5 ± 0.2 mm |
| D3 | B1 = 13.9 ± 0.2 mm |
| D4 | B1 = 11.4 ± 0.2 mm |
| D5 | B1 = 9.3 ± 0.2 mm  |
| D6 | B1 = 11.4 ± 0.2 mm |
| E1 | B1 = 10.9 ± 0.2 mm |
| E2 | B1 = 9.0 ± 0.2 mm  |
| E3 | B1 = 7.6 ± 0.2 mm  |
| E4 | B1 = 6.3 ± 0.2 mm  |
| L1 | B1 = 16.5 ± 0.2 mm |
| L2 | B1 = 12.2 ± 0.2 mm |
| L3 | B1 = 13.9 ± 0.2 mm |
| L4 | B1 = 9.9 ± 0.2 mm  |
| L6 | B1 = 18.8 ± 0.2 mm |
| L7 | B1 = 13.0 ± 0.2 mm |
| L8 | B1 = 17.1 ± 0.2 mm |
| L9 | B1 = 13.0 ± 0.2 mm |
| M1 | B1 = 13.9 ± 0.2 mm |
| Q1 | B1 = 10.4 ± 0.2 mm |
| Q2 | B1 = 9.4 ± 0.2 mm  |
| Q3 | B1 = 8.4 ± 0.2 mm  |
| Q4 | B1 = 7.4 ± 0.2 mm  |
| Q5 | B1 = 6.4 ± 0.2 mm  |

## 2.15 Pocket Centre Hole Diameter (D1)

Package style

D1, D2, D3, D4, D5, D6,  
E1, E2, E3, E4  
L1, L2, L3, L4, L6, L7, L8,  
L9  
M1  
Q1, Q2, Q3, Q4, Q5

D1 = 1.5 mm Minimum

## 3. Materials.

- 3.1. Carrier tape to be made of a conductive grade of polystyrene.
- 3.2. Conductive grade polycarbonate is also an approved carrier tape material and may be used under certain circumstances.
- 3.3. Temperature sealed cover tape is an anti static grade of PET/PE film.

## 4. Polarity & Orientation of Components in Tape

- 4.1. All components are placed such that pin 1 is adjacent to the sprocket holes (See figures 6a, 6b, 6c, 6d, 6e & 6f)
- 4.2. The mounting side of the component is oriented to the bottom side of the tape (See Figure 2).

## 5. Fixing of Components in Tape

- 5.1. The cover tape shall not cover the sprocket holes in the carrier tape

- 5.2. Tapes in adjacent layers shall not stick together in the packing.
- 5.3. The adhesive of the cover tape shall not adversely affect the mechanical and electrical characteristics and the marking of the component.
- 5.4. Components will not stick to the carrier tape or the cover tape.
- 5.5. The tapes shall be suitable to withstand storage of the taped components without danger of migration of the terminations or the giving off of vapours, which would impair soldering or deteriorate the component properties or termination by chemical action.
- 5.6. When the tape is bent with a minimum radius (See Figure 5), the tape shall not be damaged and the components shall remain in their position and orientation in the tape.
- 5.7. The peel strength of the cover tape shall be  $60 \pm 40$  grams measured at  $175^\circ - 180^\circ$  with respect to the carrier tape along its longitudinal axis. The peel speed shall be 300mm/min.
- 5.8. After baking at  $50^\circ\text{C}$  for 60 hours or storage in ideal conditions for three months the peel strength shall remain within the specified limits.

## 6. Packaging

- 6.1. The tape will be wound on anti-static high impact polystyrene reels (See Figure 4).

### 6.1.1 Dimensions (in millimetres)

| W<br>Tape<br>Width | A<br>Reel<br>Dia. | C<br>Centre<br>Hole<br>Dia. | N<br>Hub<br>Outer Dia. | W1<br>Inside<br>Cheek<br>Width | W2<br>Outside<br>Cheek<br>Width | Product types |
|--------------------|-------------------|-----------------------------|------------------------|--------------------------------|---------------------------------|---------------|
| 8                  | 330               | 13                          | 101                    | 8.8                            | 13.3                            | All           |
| 16                 | 330               | 13                          | 101                    | 16.8                           | 21.3                            | All           |
| 24                 | 330               | 13                          | 101                    | 24.8                           | 29.3                            | All except L8 |
| 24                 | 330               | 13                          | 175                    | 24.8                           | 29.3                            | L8 only       |
| 32                 | 330               | 13                          | 101                    | 32.8                           | 37.3                            | All           |

- 6.2. There will be a leader of a minimum of 400 mm of covered empty compartments.
- 6.3. In no case shall there be two or more consecutive components missing. The maximum number of missing components per reel shall be one, or 0.1% whichever is greater.
- 6.4. At the end of the tape, there will be a trailer of a minimum of 160 mm of sealed empty pockets.
- 6.5. The tape shall release from the reel hub as the last portion of the carrier tape unwinds from the reel.
- 6.6. Standard number of components on a reel:

| Package style | Minimum Quantity | Maximum Quantity |
|---------------|------------------|------------------|
| D1            | = 1,000          | 1,500            |
| D2            | = 1,000          | 1,500            |
| D3            | = 1,000          | 1,500            |
| D4            | = 1,000          | 1,500            |
| D5            | = 1,000          | -                |
| D6            | = 1,000          | -                |
| E1            | = 1,000          | 3,000            |
| E2            | = 1,000          | 3,000            |
| E3            | = 1,000          | 3,000            |
| E4            | = 1,000          | 3,000            |
| L1            | = 500            | -                |
| L2            | = 500            | -                |
| L3            | = 500            | -                |
| L4            | = 1,000          | -                |

|    |   |       |       |
|----|---|-------|-------|
| L6 | = | 500   | 500   |
| L7 | = | 1,000 | -     |
| L8 | = | 1,000 | -     |
| L9 | = | 1,000 | -     |
| M1 | = | 500   | -     |
| Q1 | = | 1,000 | 3,500 |
| Q2 | = | 1,000 | 3,500 |
| Q3 | = | 1,000 | 3,500 |
| Q4 | = | 1,000 | 3,500 |
| Q5 | = | 1,000 | 5,000 |

- 6.7. The tape will be prevented from unreeling by winding a paper tape around the reel and fixing with adhesive tape.
- 6.8. All reels will display:
  - 1. Device Type
  - 2. Quantity on reel
  - 3. A CML serial number/bar code.
  - 4. The date reel sealed.
  - 5. A static hazard warning label
- 6.9. Reels are packed in an anti-static bubble bag and a cardboard box (with appropriate labelling).
- 6.10. Ideal storage conditions for sealed tape are 15°C to 20°C with a relative humidity less than 60%.
- 6.11. Shelf life of sealed tape when stored in ideal conditions will be in excess of six months.



**DRAWINGS:**

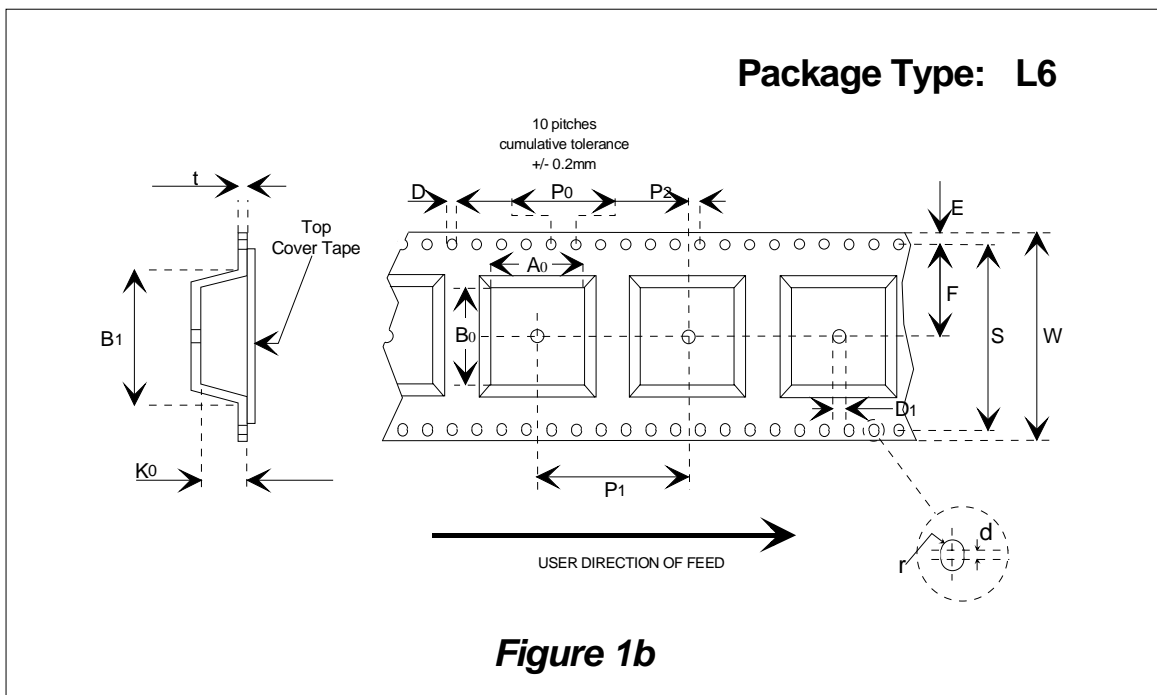
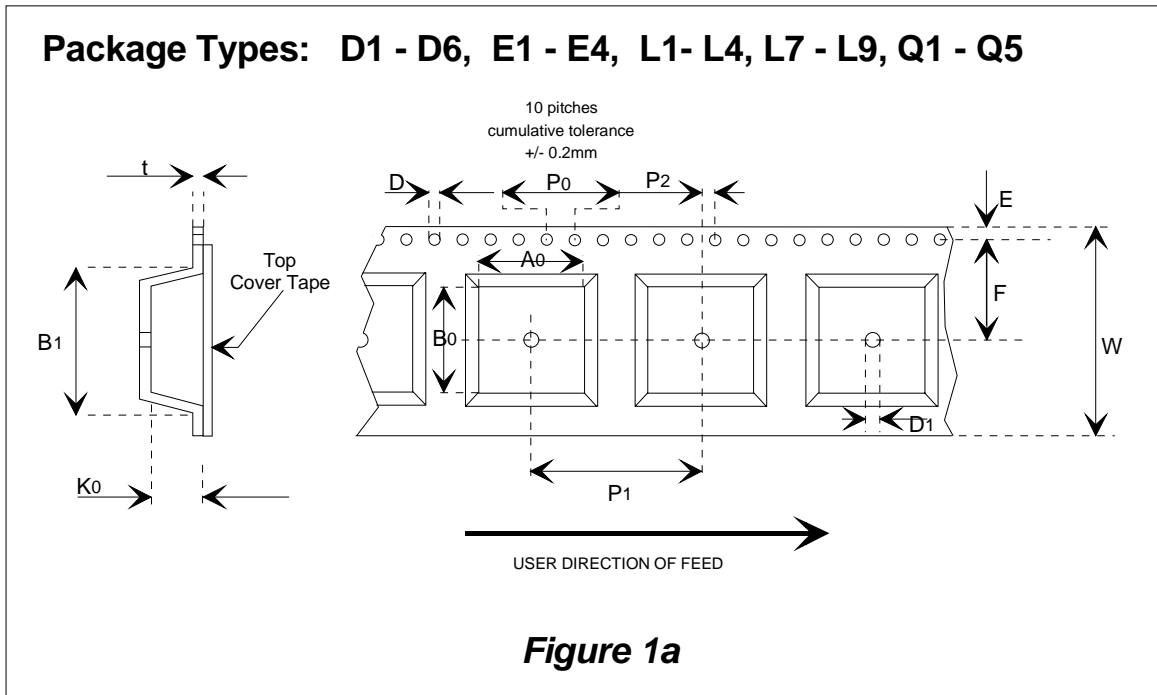

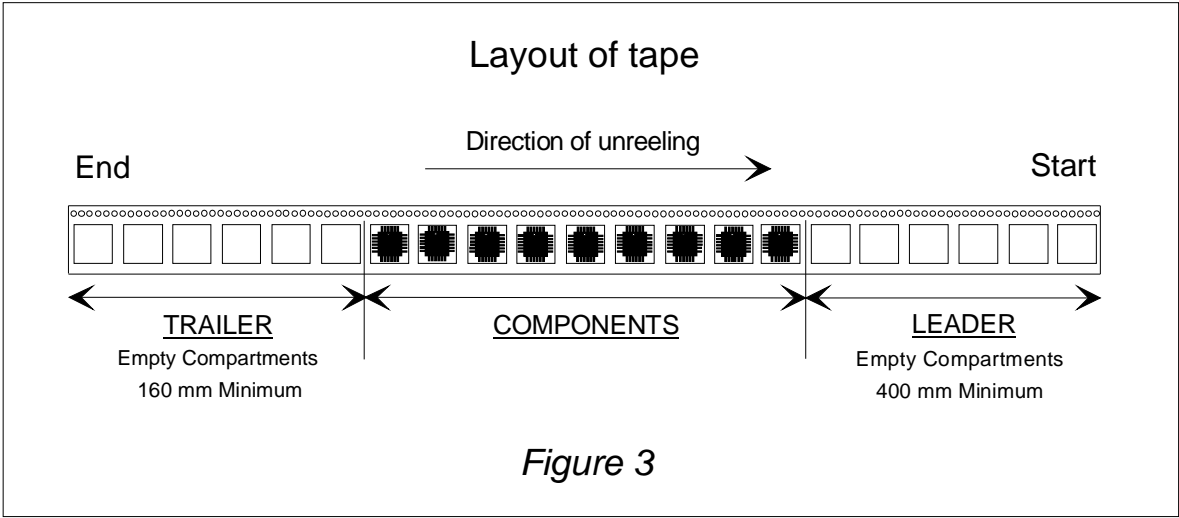
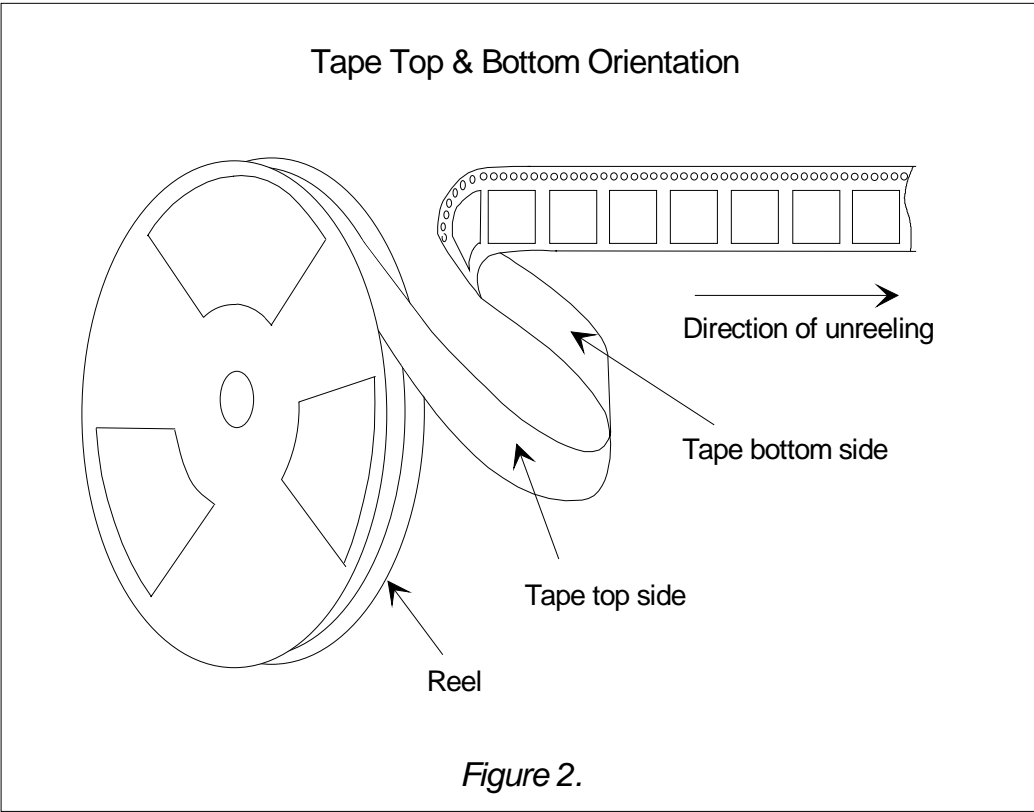

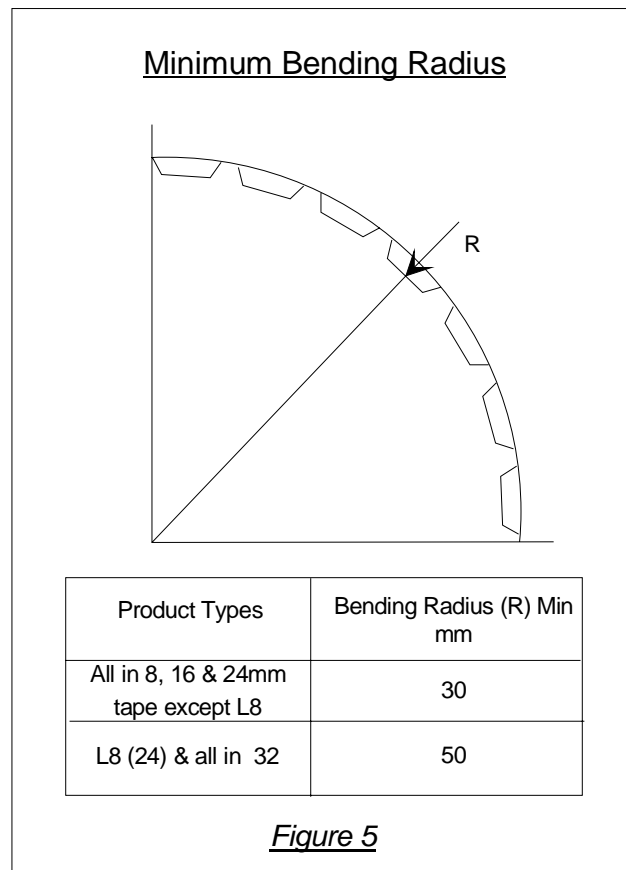
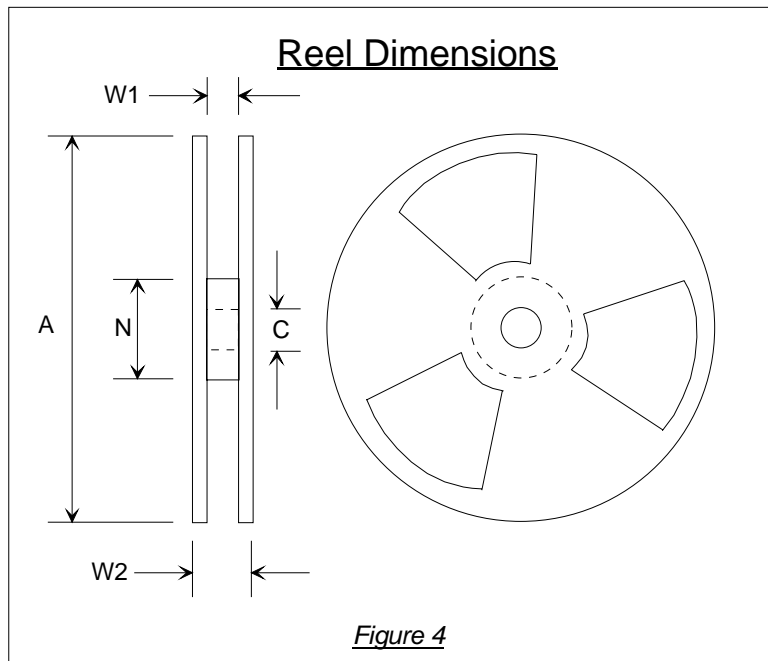

Figure 6a.

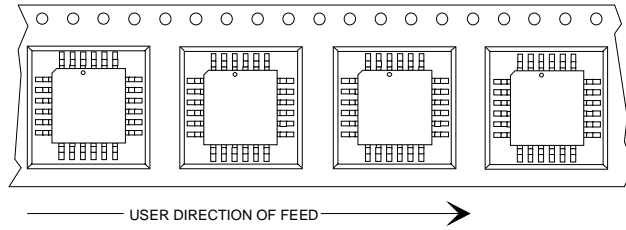

Figure 6b

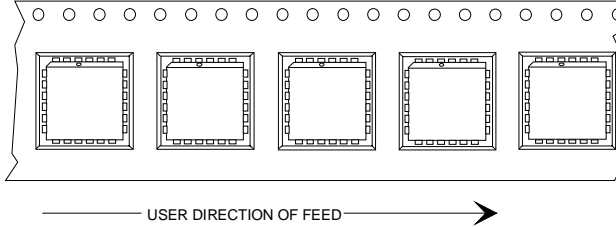

Figure 6c

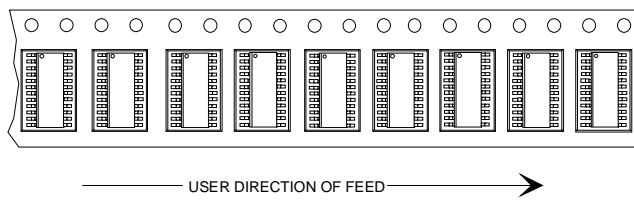

Figure 6d.

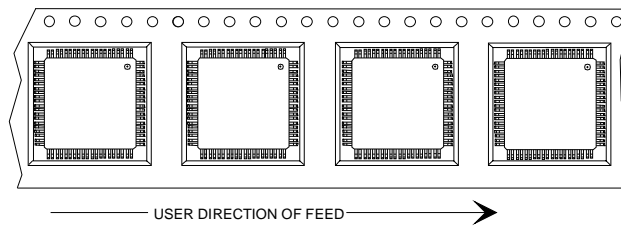

Figure 6e.

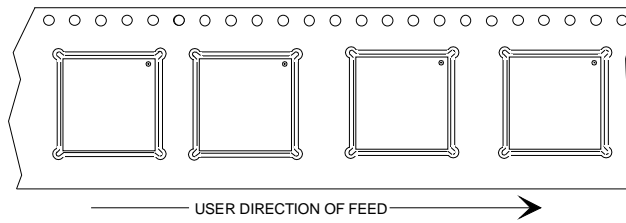

Figure 6f.

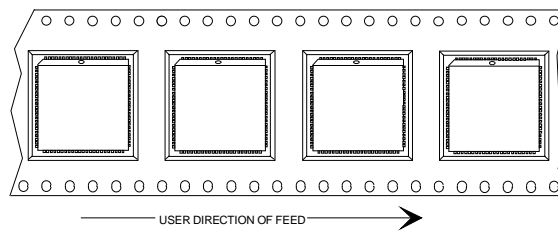





Figure 6. Component Orientation

|                                                                                                                                                                          |                                                                                                                                                                                   |                                                                                                                                                                                                                       |                                                                                                                                                                                            |
|--------------------------------------------------------------------------------------------------------------------------------------------------------------------------|-----------------------------------------------------------------------------------------------------------------------------------------------------------------------------------|-----------------------------------------------------------------------------------------------------------------------------------------------------------------------------------------------------------------------|--------------------------------------------------------------------------------------------------------------------------------------------------------------------------------------------|
|  <b>CML Microcircuits<br/>(UK) Ltd</b><br><small>COMMUNICATION SEMICONDUCTORS</small> |  <b>CML Microcircuits<br/>(USA) Inc.</b><br><small>COMMUNICATION SEMICONDUCTORS</small>        |  <b>CML Microcircuits<br/>(Singapore) Pte Ltd</b><br><small>COMMUNICATION SEMICONDUCTORS</small><br><b>Singapore</b> <b>China</b> |                                                                                                                                                                                            |
| <b>Tel:</b><br>+44 (0)1621 875500<br><b>Fax:</b><br>+44 (0)1621 875600<br><b>Sales:</b><br>sales@cmlmicro.com<br><b>Tech Support:</b><br>techsupport@cmlmicro.com        | <b>Tel:</b><br>+1 336 744 5050<br>800 638 5577<br><b>Fax:</b><br>+1 336 744 5054<br><b>Sales:</b><br>us.sales@cmlmicro.com<br><b>Tech Support:</b><br>us.techsupport@cmlmicro.com | <b>Tel:</b><br>+65 67450426<br><b>Fax:</b><br>+65 67452917<br><b>Sales:</b><br>sg.sales@cmlmicro.com<br><b>Tech Support:</b><br>sg.techsupport@cmlmicro.com                                                           | <b>Tel:</b><br>+86 21 6317 4107<br>+86 21 6317 8916<br><b>Fax:</b><br>+86 21 6317 0243<br><b>Sales:</b><br>cn.sales@cmlmicro.com.cn<br><b>Tech Support:</b><br>sg.techsupport@cmlmicro.com |
| <b>- www.cmlmicro.com -</b>                                                                                                                                              |                                                                                                                                                                                   |                                                                                                                                                                                                                       |                                                                                                                                                                                            |

© 2007 CML Microcircuits