



NLR TP 96719

Fatigue and Fracture in an Aircraft Engine Pylon

R.J.H. Wanhill and A. Oldersma

DOCUMENT CONTROL SHEET

	ORIGINATOR'S REF. NLR TP 96719 U			SECURITY CLASS. Unclassified				
ORIGINATOR National Aerospace Laboratory NLR, Amsterdam, The Netherlands								
TITLE Faigue and Fracture in an Aircraft Engine Pylon								
PRESENTED AT The International Conference "Engineering Against Fatigue", held in Sheffield, England, in March 1997.								
AUTHORS R.J.H. Wanhill and A. Oldersma			DATE 961126	<table style="width: 100%; border: none;"> <tr> <td style="text-align: center;">pp</td> <td style="text-align: center;">ref</td> </tr> <tr> <td style="text-align: center;">11</td> <td style="text-align: center;">10</td> </tr> </table>	pp	ref	11	10
pp	ref							
11	10							
<table style="width: 100%; border: none;"> <tr> <td style="width: 50%; vertical-align: top;"> DESCRIPTORS Aircraft accident investigation Causes Crack propagation Failure analysis Fittings Fractography </td> <td style="width: 50%; vertical-align: top;"> Lugs Pins Pylon mounting Separation Striation Structural failure </td> </tr> </table>					DESCRIPTORS Aircraft accident investigation Causes Crack propagation Failure analysis Fittings Fractography	Lugs Pins Pylon mounting Separation Striation Structural failure		
DESCRIPTORS Aircraft accident investigation Causes Crack propagation Failure analysis Fittings Fractography	Lugs Pins Pylon mounting Separation Striation Structural failure							
ABSTRACT Separation of an engine from a 747-200 cargo aircraft resulted in a catastrophic aircraft accident near Amsterdam. The engine separated, together with its pylon, owing to fatigue and fracture of components connecting the pylon to the wing. These components were high strength steel lugs and two "fuse pins". One fuse pin was not recovered, but the other one and the lugs were investigated to find the most probable cause and sequence of damage leading to separation.								

NLR TECHNICAL PUBLICATION

TP 96719 U

FATIGUE AND FRACTURE IN AN AIRCRAFT ENGINE PYLON

by

R.J.H. Wanhill and A. Oldersma

This paper has been prepared in the format required for the International Conference "Engineering Against Fatigue", to be held in Sheffield, England, in March 1997. It is published with the permission of the Netherlands Department of Civil Aviation (RLD).

Division : Structures and Materials

Prepared : RJHW/ AO/ 

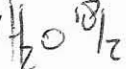
Approved : HHO/ 

Completed : 961126

Order number : 043.014

Typ. : JS



Summary

Separation of an engine from a 747-200 cargo aircraft resulted in a catastrophic aircraft accident near Amsterdam. The engine separated, together with its pylon, owing to fatigue and fracture of components connecting the pylon to the wing. These components were high strength steel lugs and two "fuse pins". One fuse pin was not recovered, but the other one and the lugs were investigated to find the most probable cause and sequence of damage leading to separation.



Contents

1.	INTRODUCTION	5
2.	THE #3 ENGINE PYLON-TO-WING CONNECTIONS	5
2.1	<i>Mid-spar pylon fittings</i>	6
2.2	<i>Outboard mid-spar fuse pin</i>	7
3.	SEPARATION OF THE #3 ENGINE AND PYLON	9
4.	REMEDIAL ACTIONS	10
5.	CONCLUDING REMARKS AND ACKNOWLEDGEMENTS	10
6.	REFERENCES	11

8 Figures

(11 pages in total)



Fatigue and Fracture in an Aircraft Engine Pylon
R.J.H. WANHILL and A. OLDERSMA
National Aerospace Laboratory NLR, Amsterdam, the Netherlands

1. INTRODUCTION

On October 4, 1992, El Al Flight 1862, a 747-200 cargo aircraft, took off from Schiphol Airport near Amsterdam. Some seven minutes later the #3 engine and pylon separated from the right wing in an outboard and rearward direction. The #3 engine hit the #4 engine, causing this engine and its pylon also to separate from the wing. Both engines and pylons fell into a lake about 25 km east of Schiphol.

During engine separation the right wing leading edge was extensively damaged. This damage, together with loss of the engines, made control of the aircraft extremely difficult (Netherlands Aviation Safety Board 1994). An attempt was made to return to Schiphol by flying several right-hand descending turns. During these turns the aircraft flew north over Amsterdam, then east, south and finally westwards to try and line up with an east-west runway. However, the aircraft became uncontrollable and crashed into an apartment block in a suburb 13 km east of Schiphol.

Subsequent investigation of the accident involved many organisations, including Boeing, Pratt and Whitney, El Al, airworthiness authorities from Israel, the Netherlands and USA, accident investigation boards from the UK and USA, the Technion Israel Institute of Technology and the NLR. Within the NLR several divisions and departments within divisions assisted in the investigation. The NLR Structures and Materials division was given the task of fractographic and metallurgical investigation of components connecting the #3 engine pylon to the right wing. These components were also investigated by Boeing, and Technion was also involved.

This paper presents the NLR's investigation of the #3 engine pylon components, done under contract to the Netherlands Department of Civil Aviation (RLD). The paper also takes into account the contribution from other investigators in order to describe the most probable cause and sequence of damage leading to separation of the #3 engine and pylon from the right wing of the aircraft. Finally, a short description is given of the measures instituted by Boeing to improve the safety of pylon-to-wing connections.

2. THE #3 ENGINE PYLON-TO-WING CONNECTIONS

Figure 1 is a schematic of the engine pylon-to-wing connections. These connections are at the aft end of the upper link, the aft end of the diagonal brace, and at the two mid-spar fittings. The design incorporates six "fuse pins" which are less strong than other parts of the connections. If extreme loads occur on an engine and pylon, for example during extreme turbulence or an emergency landing, the fuse pins are supposed to shear off and allow a clean separation from the wing, thereby precluding damage to the wing and possible rupture of the wing fuel tank. However, as found in the present case, and at least one other, engine and pylon separation was accompanied by severe damage to the wing leading edge.

Many of the components of the #3 engine pylon-to-wing connections of El Al Flight 1862 were recovered. These were (1) the forward part of the upper link, containing an intact fuse pin, (2) the diagonal brace with the forward fuse pin intact but the aft fuse pin missing, (3) the inboard mid-spar pylon and wing fittings with the fuse pin missing, (4) the outboard mid-spar pylon fitting, and (5) part of the outboard mid-spar wing fitting containing a sheared-off fuse pin.

Macroscopic inspection of the components indicated that the upper link and diagonal brace had broken away owing to overload as the #3 engine and pylon separated in an outboard direction.

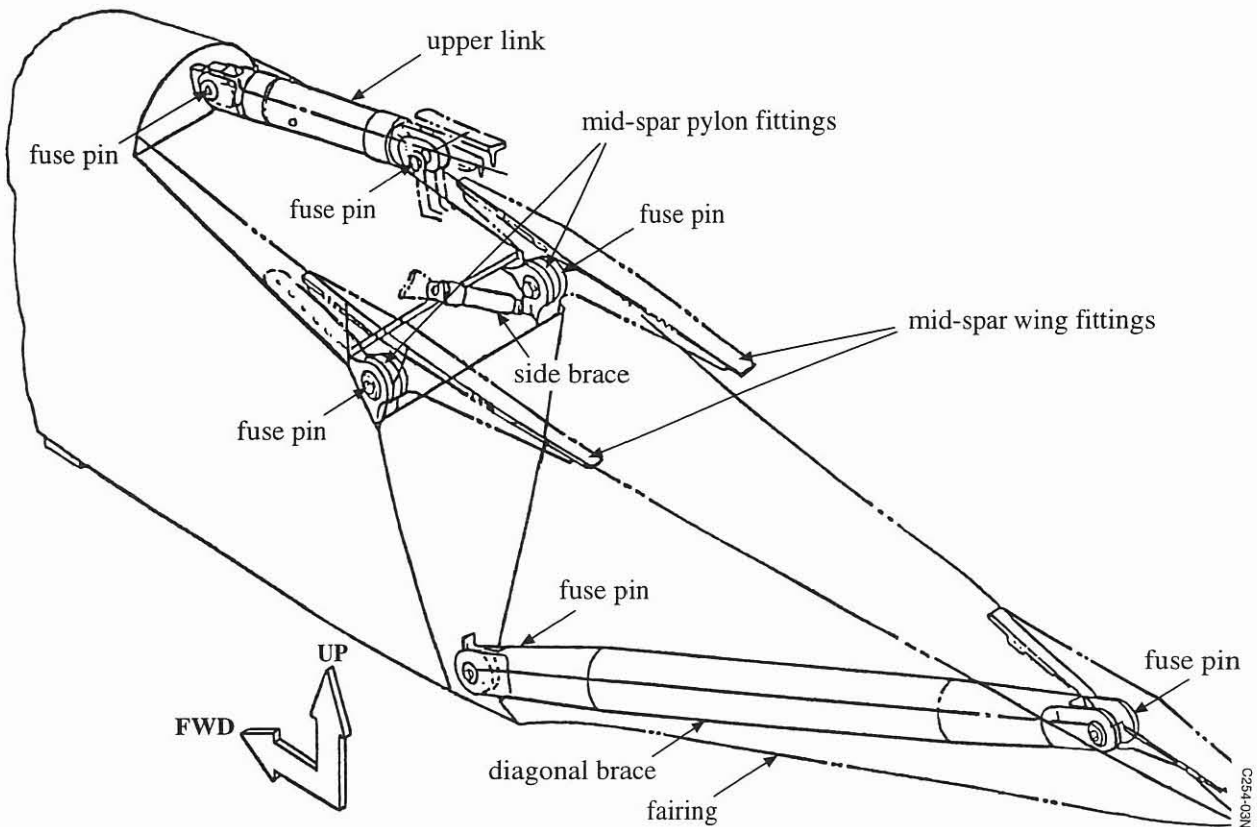

Figure 1 Pylon-to-wing connections: for the #3 pylon the left-hand side is inboard.

Attention then focussed on detailed investigation of the mid-spar components, notably the inboard and outboard pylon fittings and the sheared-off fuse pin, all of which were made from 4330M, a high strength low alloy steel.

2.1 Mid-spar pylon fittings

Figure 2 shows the mid-spar pylon fittings. Each has two lugs that had been connected via fuse pins to two male lugs on each mid-spar wing fitting. The lugs on the outboard pylon fitting were unbroken but had witness marks indicative of scraping, as did the base of the throat between the lugs (Wanhill 1992, Nash 1993a). However, the outer lug of the inboard pylon fitting was broken. Detailed examination by the NLR showed that this lug had failed by a combination of tensile and bending overload (Wanhill 1992). This was confirmed by Boeing (Nash 1993a). Also, in contrast to the outboard pylon fitting, the base of the throat between the lugs of the inboard pylon fitting was undamaged (Wanhill 1992). From these results two main conclusions were drawn:

- (1) The missing inboard mid-spar fuse pin must have failed such that the outer lug of the inboard mid-spar pylon fitting took all the load at this connection. Only thus is it possible to explain overload failure of the lug by tension and bending (Netherlands Aviation Safety Board 1994).
- (2) During failure of the inboard mid-spar connection the male lugs of the wing fitting moved outward from the throat of the lugs on the pylon fitting. On the other hand, failure of the outboard mid-spar connection resulted in the male lugs of the wing fitting moving into the throat of the lugs on the pylon fitting, thereby producing witness marks.

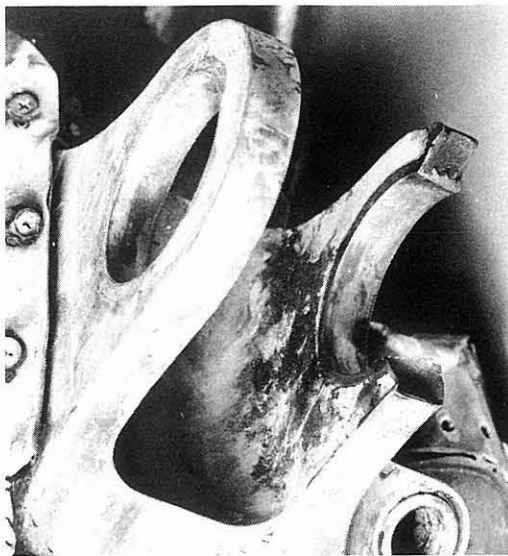

a inboard

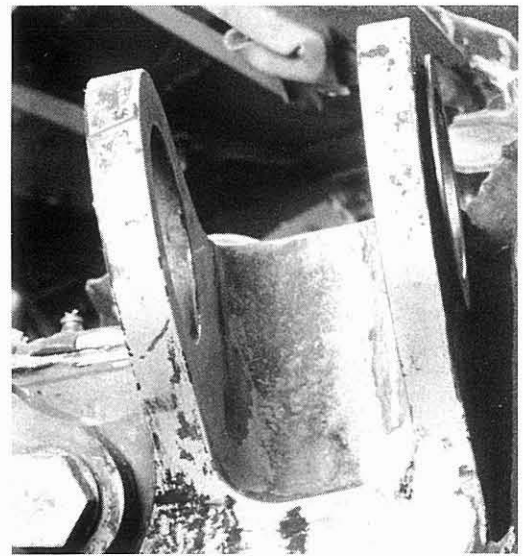

b outboard

Figure 2 The lugs of the mid-spar pylon fittings.

2.2. Outboard mid-spar fuse pin

Figure 3 shows a schematic of the outboard mid-spar connection with a cross-section of the intact fuse pin, and also the as-recovered fuse pin remnant, still in one of the male lugs of the wing fitting. The fuse pin broke at the thin-walled locations shown in cross-section in figure 3a. On the inboard side the fuse pin failed by shear overload, but on the outboard side it failed by fatigue followed by shear overload.

Figure 4 gives two macroscopic views of the outboard fracture surface of the fuse pin. The partially separated sliver in figure 4a contains a fatigue crack originally parallel to the coarse machining grooves on the inside wall of the fuse pin. Figure 4b is a detail of the fatigue crack, which initiated at multiple origins along one or more machining grooves and progressed to at least

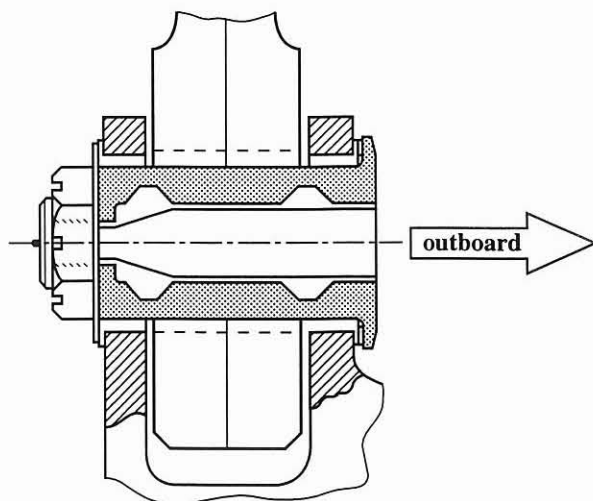

a schematic

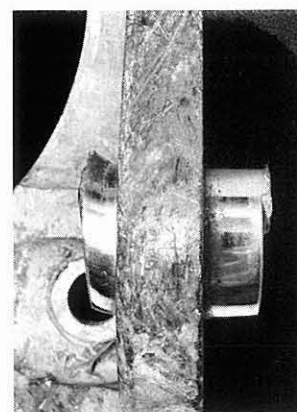

b remnant

Figure 3 Schematic and remnant of the outboard mid-spar fuse pin.

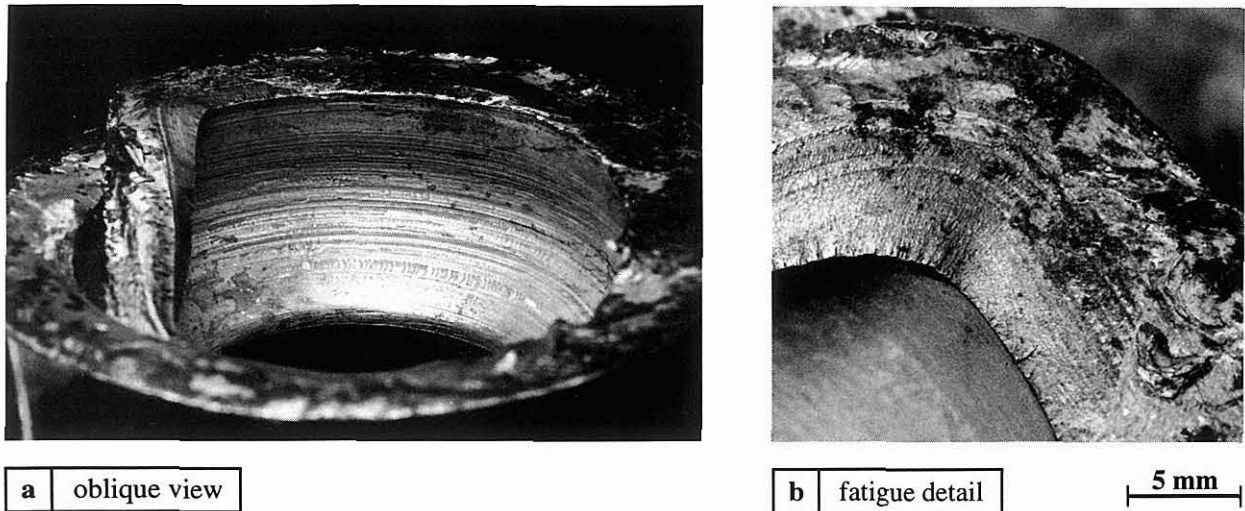

Figure 4 Outboard fracture surface of the outboard mid-spar fuse pin.

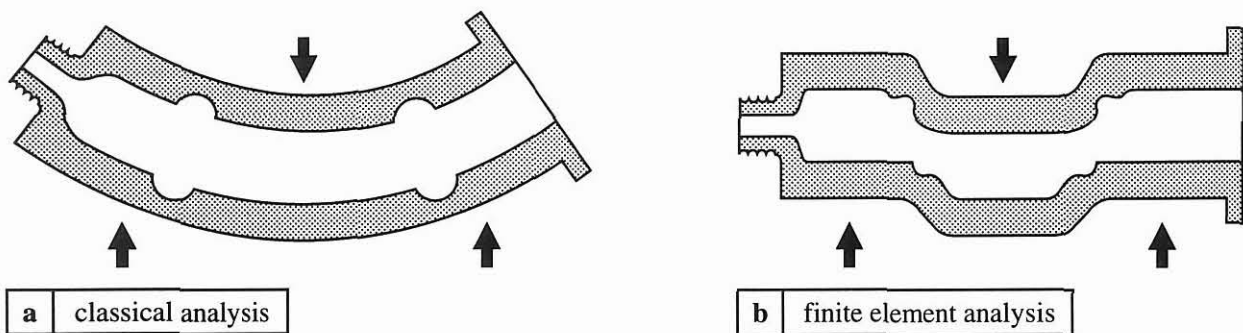

Figure 5 Fuse pin bending under service loads.

half the wall thickness before overload (Oldersma & Wanhill 1993, Nash 1993a).

The stresses causing fatigue crack initiation were due to fuse pin bending. Boeing did both a classical and finite element analysis of fuse pin bending, the results of which are shown schematically in figure 5. Boeing concluded that fuse pins undergo crankshaft deflections, leading to much higher local stresses, in the thin-walled locations, than those estimated by classical 3-point bending analysis.

Detailed fractography of the fatigue fracture in the outboard mid-spar fuse pin led to differing interpretations:

- (1) The NLR was able to examine the fatigue fracture for only a short time. We found much of the fracture surface to be severely damaged, most probably due to rubbing of the mating fracture surfaces during shear overload. However, a patch of partially rubbed and damaged fatigue "striations" was observed at a depth of 2.2 mm from the inside wall, figure 6. The spacings of the "striations" were greater than 10^{-3} mm, which would appear to indicate a high fatigue crack growth rate and hence high local stresses in the fuse pin.
- (2) Boeing conducted an extensive investigation of the fatigue fracture (Nash 1993b). They concluded that the "striations" illustrated in figure 6 represent flight-by-flight markings, and that fine striations were present between such markings. This implies that fatigue crack growth rates were much lower than would be inferred from the NLR's examination.

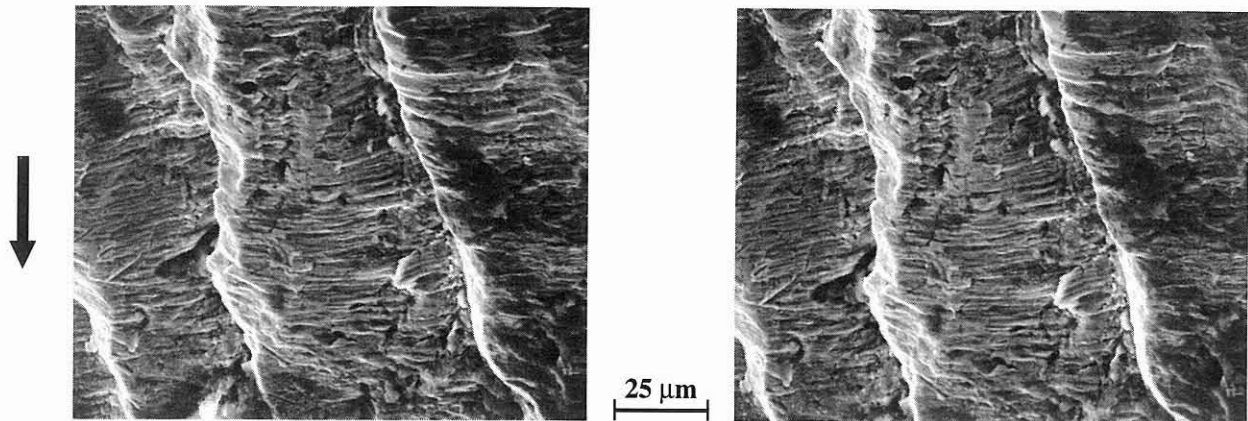

Figure 6 Stereo-pair fractographs of fatigue in the outboard mid-spar fuse pin (Oldersma & Wanhill 1993).

- (3) Technion commented on the NLR and Boeing investigations and also conducted fatigue tests on fuse pins (McEvily & Berkovitz 1993). They found fine parallel deformation markings, which did not represent load cycles, between large fatigue striations. They concluded that the "striations" illustrated in figure 6 are true cycle-by-cycle striations.

The RLD requested the NLR to comment. From the Technion results and those of others (Laird 1967, Hertzberg 1967) we concluded that since parallel deformation lines occur between striations with spacings greater than 10^{-3} mm, it is entirely possible that markings like those in figure 6 are true striations. On the other hand, the evidence presented by Boeing, though unconvincing, was no more than one would expect for minor load cycles between flight-by-flight markings on high strength steel fracture surfaces (Wanhill 1985).

Summarising, in our opinion there has not been a definitive interpretation of the fatigue fracture surface of the outboard mid-spar fuse pin. However, Boeing's analysis of fuse pin bending indicates high local stresses (the crankshafting illustrated in figure 5) and thus would appear to support Technion's interpretation that the markings in figure 6 represent true striations.

3. SEPARATION OF THE #3 ENGINE AND PYLON

The Netherlands Aviation Safety Board considered several scenarios for separation of the #3 engine and pylon from the right wing. Figure 7 shows the most probable sequence of events, described as follows:

- (1) Gradual failure by fatigue and then overload failure of the inboard mid-spar fuse pin at the inboard thin-walled location.
- (2) Overload failure of the outer lug of the inboard mid-spar pylon fitting.
- (3) Overload failure of the outboard mid-spar fuse pin at the outboard thin-walled and fatigue-cracked location.
- (4) Overload failure of the outboard mid-spar fuse pin at the inboard thin-walled location.

The Board concluded that overload failure of the inboard mid-spar fuse pin and the subsequent overload failures all occurred during the last flight. This has subsequently been disputed because an

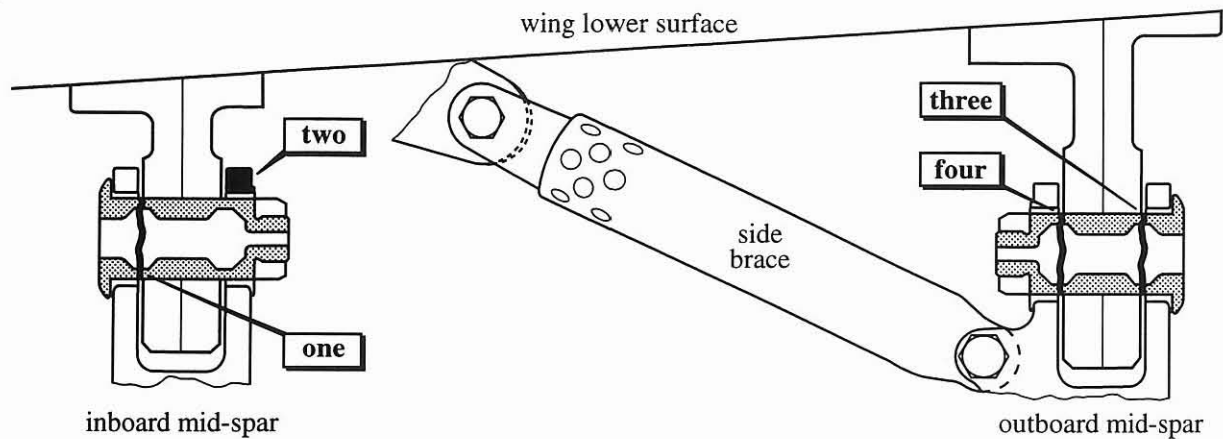

Figure 7 Probable sequence of separation of the #3 engine pylon from the right wing.

aircraft spotter took photographs of El Al Flight 1862 when it landed at Schiphol on October 4, 1992. From these photographs it appears that the #3 engine had an upward tilt relative to the other engines, and the question arose whether this apparent tilt could have been caused by disconnections between the pylon and wing. However, a recent report (Walraven, de Vries & Alferdinck 1996) concluded that the apparent upward tilt is an optical illusion.

4. REMEDIAL ACTIONS

Boeing instituted several remedial actions for the pylon-to-wing connections, some of which are shown in figure 8. These actions were:

- (1) A new design fuse pin made from corrosion resistant stainless steel and without thin-walled locations, compare figures 3a and 8a. This type of pin has a much improved resistance to fatigue.
- (2) Two extra connections between the mid-spar pylon fittings, figure 8b.
- (3) Larger mid-spar pylon fittings and stronger diagonal brace and upper link.

These remedial actions are to prevent an engine and pylon separating from the wing under extreme loads in flight, i.e. the concept of clean separation during flight has been abandoned. This is because the concept has not worked, neither for El Al Flight 1862 nor for two other aircraft: a China Air 747 cargo which also lost the #3 and #4 engines, in December 1991, and an Evergreen Airlines 747 cargo which lost the #2 engine with extensive damage to the left wing leading edge in March 1993. Nevertheless, it is still the intention that during a ground impact the engines and pylons break away without damage to the wing fuel tank.

5. CONCLUDING REMARKS AND ACKNOWLEDGEMENTS

The severity of the El Al Flight 1862 accident resulted in one of the most complicated and thorough investigations in the history of aviation. Many organisations and technical disciplines were involved. The NLR's investigation of the mid-spar components of the #3 engine pylon-to-wing connections proved to be an essential part of determining the cause of the accident and how it happened. We are grateful to the Netherlands Department of Civil Aviation (RLD) for permission to publish this paper.

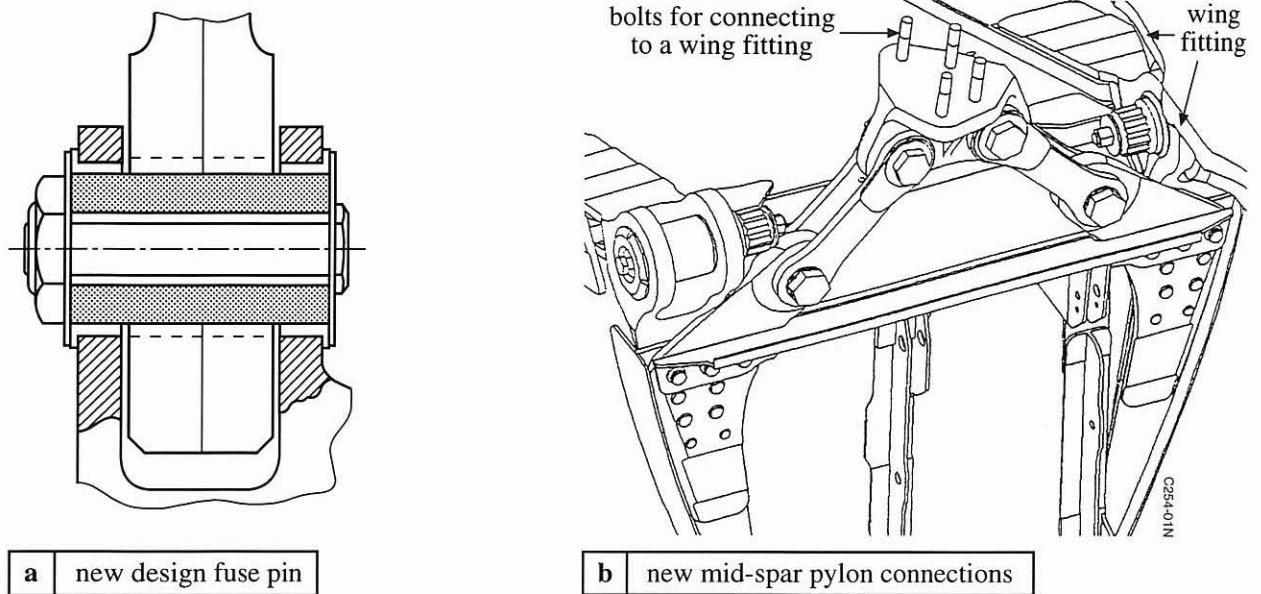

Figure 8 Illustration of remedial actions for the mid-spar pylon connections.

6. REFERENCES

- Hertzberg, R.W. 1967. Fatigue fracture surface appearance. In *Fatigue Crack Propagation, ASTM STP 415*: 205-224. Philadelphia: American Society for Testing and Materials.
- Laird, C. 1967. The influence of metallurgical structure on the mechanisms of fatigue crack propagation. In *Fatigue Crack Propagation, ASTM STP 415*:131-168. Philadelphia: American Society for Testing and Materials.
- McEvily, A.J. & Berkovitz, A. 1993. Analysis of outboard fuse pin failure on El Al 4X-AXG, engine #3. Technion Israel Institute of Technology Report ASL-147.
- Nash, R.A. 1993a. Metallurgical investigation of El Al Israel Airlines 747-200 freighter inboard midspar fitting, outboard midspar fitting, and outboard midspar fuse pin from the number 3 strut. Boeing Materials Technology Report MS 21646.
- Nash, R.A. 1993b. Addendum to MS 21646, Revision A. Boeing Materials Technology Report MS 21646 Addendum, Revision A.
- Netherlands Aviation Safety Board, 1994. Aircraft Accident Report 92-11, El Al Flight 1862, Boeing 747-258F 4X-AXG, Bijlmermeer, Amsterdam, October 4, 1992.
- Oldersma, A. & Wanhill, R.J.H. 1993. Investigation of the outboard mid-spar fuse pin from the pylon of engine #3 of El Al Flight 1862. National Aerospace Laboratory NLR Contract Report 93030 C.
- Walraven, J., de Vries, S.C. & Alferdinck, J.W.A.M. 1996. Relative differences in the position of the engines of the El Al Boeing 4X-AXG on 04-10-'92; an evaluation on the basis of photographic evidence. TNO Report TM-96-C050 (in Dutch).
- Wanhill, R.J.H. 1985. Fatigue fracture in steel landing gear components. National Aerospace Laboratory NLR Miscellaneous Publication 85050 U.
- Wanhill, R.J.H. 1992. Investigation of the inboard mid-spar fitting from the pylon of engine #3 of El Al Flight 1862. National Aerospace Laboratory NLR Contract Report 92454 C.

