

ROLE OF THREE GORGES - CHANGZHOU HVDC IN INTERCONNECTING CENTRAL AND EAST CHINA

ABHAY KUMAR
ABB

(Sweden)

YUAN QINGYUN
POWER GRID DEVELOPMENT BRANCH OF THE
STATE POWER CORPORATION OF CHINA
(P. R. China)

The Three Gorges - Changzhou ± 500 kV DC Transmission Project is an integral part of the Three Gorges Hydroelectric Power Project. The DC transmission will be used to transmit the bulk power generated by this project to the Shanghai area in East China. The project will interconnect the central power region of China, to which the hydroelectric power plant will be connected synchronously, to the eastern power region of China. The power will be transmitted towards the east during the peak generation period and towards the centre when water needs to be conserved in the dam reservoir. The 3000 MW rated power will be transmitted to a distance of 860 km on one single bipolar DC line at ± 500 kV. The paper describes the project's role in interconnecting power regions and specific benefits of this project, which is scheduled to be commissioned in 2002-2003.

Keywords: Three Gorges – Bulk - Bipolar – Transmission - Interconnection - System - HVDC

1. SHORT DESCRIPTION OF THE PROJECT

The 3000 MW Three Gorges - Changzhou ± 500 kV DC (3GC) Transmission Project is a bipolar transmission with one converter station in Longquan (in Yichang County in Hubei Province) and the other in Zhengping (in the city of Changzhou, Jiangsu Province) in The People's Republic of China. The Longquan rectifier converter station is located approximately 50 km from the site of the Three Gorges hydro dam. The normal receiving station at Zhengping is located approximately 200 km from the city of Shanghai. The general arrangement for the 3GC Project is shown in Figure 1.

Both sending and receiving AC systems are strong and only switchable filter/capacitor banks on the converter station AC buses are used as compensation equipment. At Longquan there are eight switchable sub-banks with a total capacity of 1076 Mvar. Three of those are HP11/13 (140 Mvar), three HP24/36 (140 Mvar) and remaining two as HP3 (118 Mvar). In

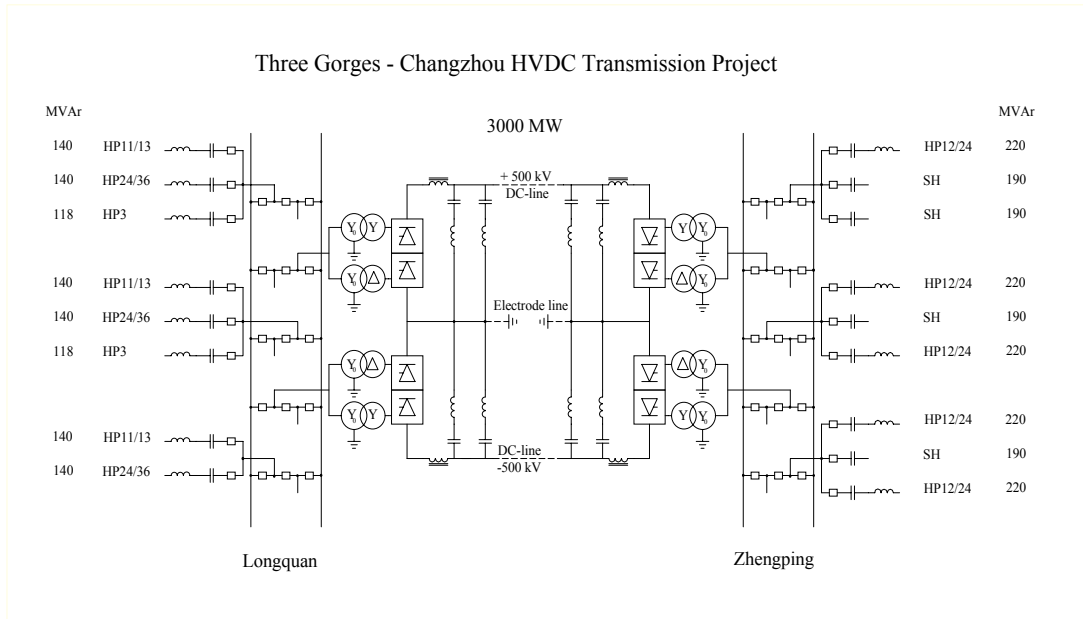

Fig. 1. Simplified system configuration

addition, at Longquan, 4 50 Mvar low voltage capacitors are installed on the 35 kV tertiary of the 500 kV/220 kV auto-transformer.

A total of 1860 Mvar is provided in Zhengping, divided into nine switchable sub-banks; four of which are pure shunt capacitors, each rated for 190 Mvar. The remaining five are HP12/24 filter sub-banks, each rated for 220 Mvar.

2. INTEGRATION INTO THE POWER SYSTEM

The beneficiaries of Three Gorges Hydro-electric Power Project include eight provinces and two metropolitan cities along the Yangtze river. Power and energy from the 18 200 MW (26 x 700) power station will be sent to central China and Sichuan Provincial Grid & Chongqing Power Grid by 500 kV AC transmission lines and to the eastern China by three HVDC links interconnecting the two large AC systems, asynchronously.

The Three Gorges - Changzhou DC Transmission Project is the second project, to connect central China and eastern China asynchronously. The first is the 1200 MW, ± 500 kV Gezhouba-Shanghai DC transmission link, which has been operating for several years. There are also plans to install a third 3000 MW DC transmission (3GS) link to Shanghai area in the next few years in parallel to these two (Figure 2). Another 3000 MW DC transmission will bring power from Three Gorges to Guangdong in 2004, thus also interconnecting southern China network also with the central and eastern.

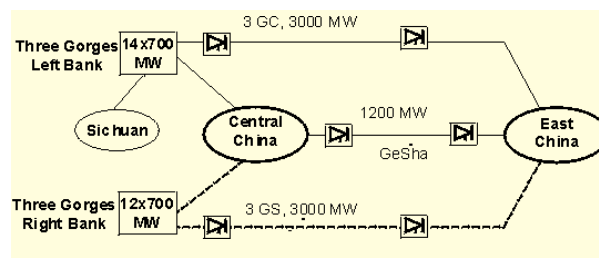

Fig. 2. HVDC Interconnecting Eastern with Central China

3. BENEFITS OF INTEGRATION

Apart from its normal use of the controlled transmission of bulk power from the Three Gorges Hydro-electric station, the 3GC Project will provide additional benefits. The project plays a positive role in the promotion of a nationwide interconnected power grid, thus enabling the sharing of peak load, to benefit from the ability to transfer load to utilise fully the generating capacity and power energy; whereas on the other hand its benefits among many others include the interconnection of two large networks without adding their short circuit capacities, supporting other network in emergencies plus a tool for economic energy management.

3.1. Economic Energy Management Tool

The central network has hydro-rich generation, whereas eastern China network has thermal-rich generation. Energy management of the combined pool of hydro-thermal generation can be optimised by operating it at its highest efficiency, and by adjusting power transmission on the HVDC link. With the 3GC Project in place, it will be possible to operate the thermal generation to supply base load, where it gives greatest efficiency, irrespective of load demand in just eastern China. Hydro generation from central China can then be utilised to meet the peak demand of the two regions together. The water in the reservoir can be conserved for later use, if required, by transmitting the power from eastern to central, when base thermal generation exceeds the load of the eastern region alone, as the direction of power flow on the DC transmission system can be reversed in a quick and controlled manner.

3.2 Supporting Other Network

The DC transmission will help one network at the time of need, by providing support from the other network. For this purpose a frequency control function is employed. It will assist the distribution of the deficit/excess of power in either the central or the eastern Systems between them, within the limits of its capacity. The controlling principle is to regulate the HVDC power based on considerations of the frequency in the two systems.

The frequency controller principle assists the balance of power loss/change between the systems and still reduces the impact on the healthy system in order to prevent it deviating from its pre-defined frequency limits. When the frequency of the primarily disturbed system exceeds the dead band limits (0.2 Hz), it will activate a power order change (P_{dc}) to reduce the frequency deviation.

The dc power change may cause the healthy (primarily undisturbed system) to change its frequency. If its frequency also exceeds the dead band limits (0.2 Hz), it will activate a power order to reduce (counteract) the change (P_{dc}) in order to reduce its change in frequency deviation.

3.3 Continued Transmission

Under certain ambient/pollution conditions, the line insulation may not withstand rated voltage for a certain period of time. In order to uphold transmission, even in such period, the transmission is designed to operate continuously at a reduced DC voltage of 350 kV. This ensures that the power transmission on the 3GC link will be continued, in spite of unfavourable ambient conditions. As pollution in the region close to Shanghai is considered to be very heavy, all high voltage DC equipment are located indoors in DC halls and capacitor halls and connected to the DC line through wall bushings.

3. PROJECT EQUIPMENT

3.1 Main Equipment

Physically each converter is built up of twelve (air insulated, water-cooled) single valves arranged in six units. Each suspended unit consists of two single valves combined into one mechanical unit called a double valve (Figure 3). The valve structure is suspended from the ceiling, which gives a superior mechanical design for all static and dynamic conditions. The light guides for control and monitoring, as well as the cooling water connection pipes, enter from the ceiling of the valve hall. There are 90/84 thyristors per valve at Longquan/Zhengping respectively. The thyristors used are 5" (YST90) and are identical for the two stations.



Fig. 3. Double Valve Arrangement

The converter transformers are of the single phase two-winding type with two wound legs. The nominal parameters of the Longquan transformers are 297.5 MVA, 525/210.4 kV, 16% reactance, with an OLTC tap range of +25/-5, each step being 1.25%. The nominal parameters of the Zhengping transformers are 283.7 MVA, 500/200.4 kV, 16% reactance, with an OLTC tap range of +26/-2, each step being 1.25%. The bushings penetrating to the valve hall are of the dry type. The converter transformers for Longquan are also equipped with ETCS (Electronic Transformer Control System) which includes analysis and reporting and intelligent fan control to minimise losses.

For this project, oil insulated smoothing reactors with a reactance of 290/270 mH are used in each pole at Longquan/Zhengping respectively. All bushings are of the composite type. The smoothing reactors are connected to the valves with the bushing penetrating through the valve hall wall.

Zero-flux type DC current transducers are used on the neutral buses. On the pole buses optical DC current transducers (DC-OCT) are used. By using optical fibre to transmit signals from the high voltage level to ground and by sensing the current with a shunt, the diameter of the optical link insulator to ground is greatly reduced thereby drastically improving its performance against flashovers due to pollution. For direct voltage measurement on the pole bus, resistive voltage dividers with polymer housings are used.

SF₆ interrupters are used for all high-speed DC switches. The Metallic Return Transfer Breaker, Neutral Bus Switch and Neutral Bus Grounding Switch have an active auxiliary transfer circuit, whereas the Ground Return Transfer Switch uses a passive auxiliary circuit. 500 kV AC switchgear for AC filters uses COMPACT switchgear i.e. breaker, disconnecter, grounding switches and optical CT using one common structure and foundation, thus saving valuable space and providing ease of installation and maintenance.

3.2 Control and Protection System

The most up-to-date HVDC technology and advanced MACH2 (Modular Advanced Control for HVDC) computerised controls are used. MACH2 is a high-performance, high-integrated system with no maintenance requirements, a very powerful programming environment and close integration with the SCADA system. The inter-station communication for this project is via OPGW. Information about operating status, settings of control and protection systems, as well as fault records can be accessed from the opposite terminal and remote dispatch and control centres.

The MACH2 system is designed specifically for HVDC converters in power applications and uses state-of-the-art computers and digital signal processors, connected by high performance industry standard buses and fibre optic communication links.

Software engineering is facilitated and program quality is improved by the use of comprehensive and easy-to-use, fully graphical, software development tools which ensure fast and accurate programming. Graphic programming is done with the powerful HiDraw facility. The entire control software can be downloaded to EMTDC for studies to fine-tune the control parameters.

A fully digital on-line operator guideline and plant documentation system will be included. The HVDC link is normally operated from the sophisticated Station Control and Monitoring system (better known as the SCADA), which is an integral part of the control system. Alarms and events are generated in the actual control and protection software applications. Upgrading and adding of new functions is very easy since the entire system is software based.

3.3 Domestic Equipment

Some of the major DC equipment, which include converter transformers, smoothing reactors and thyristor valves have successfully been produced in China and has already been installed at the respective stations. Domestically produced converter transformers for receiving station are now due to arrive at site in the beginning of 2003.

4. PRESENT STATUS (DECEMBER 2002)

The project execution is very satisfactory. Commissioning work for Pole 1 at both sites is progressing well. System Tests, including heat run test for Pole 1 have already been completed successfully for normal power direction. The System Tests for reverse power direction are progressing with a completion target of before the end of the year. Pole 2 will be commissioned in 2003 as per the time schedule.

5. ACKNOWLEDGEMENT

The authors gratefully acknowledge the valuable guidance and support given by Mr. Mats Lagerkvist and Mr. Sun JiaJun, Project Managers from ABB/SPG respectively, in the writing of this paper.

6. REFERENCES

- [1] Hao Guo, "Survey of Three Gorges Power Grid (TGPG)", [IEEE2000 (0-7803-5938-0/00)]
- [2] Z. Xiaoqian, D. Gongyang, G. Ricai, "The Three Gorges power grid and its development", [Cigré 1998, 37-203, Paris]
- [3] Zhou Xiaoqian, et.al., "Design Features of The Three Gorges - Changzhou ± 500 kV DC Project", [Cigré 2000, 14-206, Paris]

RESUME

Le projet de transport en CC à ± 500 kV Les Trois Vallées – Changzhou fait partie intégrante du projet d'aménagement hydroélectrique des Trois Vallées. Le transport en CC sera utilisé pour transmettre l'énergie haute tension produite par cet ouvrage jusqu'à la zone de Shanghai dans l'Est de la Chine. Ce projet assurera l'interconnexion entre la région centrale de la Chine, à laquelle la centrale hydroélectrique sera connectée de façon synchrone, et la région orientale. L'énergie sera transportée vers l'est durant la période de crête de la production et vers le centre lorsqu'il sera nécessaire de conserver l'eau dans la retenue du barrage. La puissance nominale de 3000 MW sera transportée sur une distance de 860 km par une seule ligne CC bipolaire à ± 500 kV. Le présent rapport décrit le rôle que joue ce projet en interconnectant les régions en question et les avantages spécifiques de ce projet dont la mise en service est programmée en 2002 – 2003.

En plus de l'utilisation normale pour la transmission contrôlée de l'énergie haute tension fournie par l'usine hydroélectrique des Trois Vallées, ce projet comportera d'autres avantages. D'une part, ce projet joue un rôle positif dans la promotion d'un réseau interconnecté à l'échelle nationale, permettant ainsi de répartir le pic de charge, de bénéficier des décalages de charge et d'utiliser pleinement les capacités de production en énergie et en puissance. D'autre part, parmi beaucoup d'autres avantages, il apporte celui d'interconnecter deux grands réseaux électriques sans additionner leurs puissances de court-circuit, de secourir l'autre réseau en cas d'urgence et de constituer en outre un outil pour une gestion économique de l'énergie.

La production d'origine hydraulique est prédominante dans le réseau du centre de la Chine tandis que la production d'origine thermique prédomine dans le réseau de l'est. La gestion optimale de l'énergie peut se réaliser pour l'ensemble des moyens de production hydrauliques et thermiques en les exploitant à leurs meilleurs rendements et en ajustant le transport d'énergie sur la liaison CCHT. Le transport en CC aidera l'un des réseaux en cas de besoin en lui fournissant un soutien par le moyen d'une fonction de réglage de la fréquence. Il viendra en aide dans la répartition d'un déficit ou d'un excédent de puissance entre les réseaux du centre et de l'est.

La réalisation du projet progresse de façon très satisfaisante. Les travaux de mise en service pour le pôle 1 sur les deux sites progressent bien. Les essais système pour le pôle 1 ont été achevés avec succès pour le sens normal d'écoulement de l'énergie. Le pôle 2 sera mis en service en 2003 dans les délais prévus.