NON-THERMAL EFFECTS AND MECHANISMS OF INTERACTION BETWEEN ELECTROMAGNETIC FIELDS AND LIVING MATTER

An ICEMS Monograph



RAMAZZINI INSTITUTE

Edited by
Livio Giuliani and Morando Soffritti

European Journal of Oncology

Eur. J. Oncol. - Library Vol. 5

National Institute for the Study and Control of Cancer and
Environmental Diseases "Bernardino Ramazzini"

Bologna, Italy

2010

Ramazzini Institute
Eur. J. Oncol. Library

Volume 5



Technical Editor
Erica Tommasini

Editorial Staff
Damiano Accurso
Luciano Bua
Daniela Chiozzotto
Laura Falcioni
Michelina Lauriola
Marco Manservigi
Eva Tibaldi

**NON-THERMAL EFFECTS AND
MECHANISMS OF INTERACTION
BETWEEN ELECTROMAGNETIC
FIELDS AND LIVING MATTER**

An ICEMS Monograph

RAMAZZINI INSTITUTE EUR. J. ONCOL. LIBRARY
Volume 5

NON-THERMAL EFFECTS AND MECHANISMS OF INTERACTION BETWEEN ELECTROMAGNETIC FIELDS AND LIVING MATTER

An ICEMS Monograph



Edited by
Livio Giuliani and Morando Soffritti

National Institute for the Study and Control of Cancer and
Environmental Diseases "Bernardino Ramazzini"
Bologna, Italy
2010



RAMAZZINI INSTITUTE

SPONSORS



International Commission for Electromagnetic Safety



National Institute for the Study and Control of Cancer and
Environmental Diseases "Bernardino Ramazzini"

This work is subject to copyright. All rights are reserved, whether the whole or part of the material is concerned, specifically the rights of translation, reprinting, re-use of illustrations, recitation, broadcasting, reproduction on microfilms or in other ways, and storage in data banks. Duplication of this publication or parts thereof is only permitted under the provisions of the Italian Copyright Law in its current version and permission for use must always be obtained from Mattioli. Violations are liable for prosecution under the Italian Copyright Law.

The use of registered names, trademarks, etc. in this publication does not imply, even in the absence of a specific statement, that such names are exempt from the relevant protective laws and regulations and therefore free for general use.

Product liability: the publishers cannot guarantee the accuracy of any information about dosage and application contained in this book. In every individual case the user must check such information by consulting the relevant literature.

isbn
978-88-6261-166-4

pubblicazione
FIDENZA 2010



© Mattioli 1885 spa

CONTENTS

Preface	
M. Soffritti	VII
Why investigate the non thermal mechanisms and effects of electromagnetic fields on living systems? An introduction	
L. Giuliani	IX
SECTION A. BIOPHYSICAL MECHANISMS	
On mechanism of combined extremely weak magnetic field action on aqueous solution of amino acid	
M. Zhadin	1
Coherence in water and the kT problem in living matter	
E. Del Giudice, L. Giuliani	7
Water structures and effects of electric and magnetic fields	
S. Tigrek, F. Barnes	25
Weak low-frequency electromagnetic fields are biologically interactive	
A.R. Liboff	51
Oxidative stress-induced biological damage by low-level EMFs: mechanisms of free radical pair electron spin-polarization and biochemical amplification	
C.D. Georgiou	63
SECTION B. CELLULAR MECHANISMS AND TISSUES EFFECTS	
Effect of extremely low electromagnetic frequency on ion channels, actin distribution and cells differentiation	
M. Ledda, S. Grimaldi, A. Lisi, E. D'Emilia, L. Giuliani	115
Genotoxic properties of extremely low frequency electromagnetic fields	
I. Udroui, L. Giuliani, L.A. Ieradi	123
Extremely-low frequency magnetic field modulates differentiation and maturation of human and rat primary and multipotent stem cells	
M. Ledda, F. De Carlo, E. D'Emilia, L. Giuliani, S. Grimaldi, A. Lisi	135
Immunotropic effects of low-level microwave exposure <i>in vitro</i>	
W. Stankiewicz, M.P. Dąbrowski, E. Sobiczewska, S. Szmigielski	149
Cellular enzymatic activity and free radical formation in various tissues under static and ELF electric and magnetic field exposure	
N. Seyhan, A.G. Canseven, G. Guler, A. Tomruk, A. Firlarer	157
Polarizability of normal and cancerous tissues, a Radiofrequency Nonlinear Resonance Interaction non invasive diagnostic Bioscanner Trimprob detector	
C. Vedruccio	177
Dependence of non-thermal biological effects of microwaves on physical and biological variables: implications for reproducibility and safety standards	
I.Y. Belyaev	187

SECTION C. IN VIVO EFFECTS

- Mega-experiments on the carcinogenicity of Extremely Low Frequency Magnetic Fields (ELFMF) on Sprague-Dawley rats exposed from fetal life until spontaneous death: plan of the project and early results on mammary carcinogenesis**
M. Soffritti, F. Belpoggi, M. Lauriola, E. Tibaldi, F. Manservigi,
D. Accurso, D. Chiozzotto, L. Giuliani 219
- The weak combined magnetic fields induce the reduction of brain amyloid- β level in two animal models of Alzheimer's disease**
N.V. Bobkova, V.V. Novikov, N.I. Medvinskaya, I.Y. Aleksandrova,
I.V. Nesterova, E.E. Fesenko 235
- Delayed maturation of *Xenopus laevis* (Daudin) tadpoles exposed to a weak ELF magnetic field: sensitivity to small variations of magnetic flux density**
M. Severini, L. Bosco 247
- Is cognitive function affected by mobile phone radiation exposure?**
A.F. Fragopoulou, L.H. Margaritis 261
- Provocation study using heart rate variability shows microwave radiation from DECT phone affects autonomic nervous system**
M. Havas, J. Marrongelle, B. Pollner, E. Kelley, C.R.G. Rees, L. Tully 273
- Comparative assessment of models of electromagnetic absorption of the head for children and adults indicates the need for policy changes**
Y.-Y. Han, O.P. Ghandi, A. DeSalles, R.B. Herberman, D.L. Davis 301
- Investigation on blood-brain barrier permeability and collagen synthesis under radiofrequency radiation exposure and SAR simulations of adult and child head**
N. Seyhan, G. Guler, A. Canseven, B. Sirav, E. Ozgur, M.Z. Tuysuz 319
- Effects of microwave radiation upon the mammalian blood-brain barrier**
L.G. Salford, H. Nittby, A. Brun, J. Eberhardt, L. Malmgren, B.R.R. Persson 333
- ## SECTION D. EPIDEMIOLOGY
- Carcinogenic risks in workers exposed to radiofrequency and microwave radiation**
S. Szmigielski 357
- Wireless phone use and brain tumour risk**
L. Hardell 363
- Occupational EMF exposure measurements in different work environments**
N. Seyhan, A. Fırlarer, A.G. Canseven, S. Özden, S. Tepe Çam 379
- Exposure to electromagnetic fields and human reproduction: the epidemiologic evidence**
I. Figà-Talamanca, P. Nardone, C. Giliberti 387

Preface

Morando Soffritti

Cesare Maltoni Cancer Research Center, Ramazzini Institute, Bologna, Italy

Electromagnetic fields are waves that transport energy through space. They are characterized by wavelength and frequency, the two of which are inversely correlated. The shorter the wavelength, the greater the frequency.

Electromagnetic fields include the following (in order of decreasing wavelength and increasing frequency): electromagnetic fields of extremely low frequency (from electric sources), electromagnetic fields of low frequency, electromagnetic fields of radiofrequency and microwaves (from mobile telephones, television antennas etc), ultrasounds, infrared rays, ultraviolet rays, X rays and gamma rays. Gamma rays, given their energy charge, are also defined as ionizing radiation, and are capable of altering genetic cellular material. Indeed, the carcinogenic effects of ionizing radiation have been known for decades.

Scientific data regarding the long-term effects, in particular carcinogenic risk, of the exposure to non-ionizing electromagnetic fields were not reported in the literature until the 1970s. In 1979 two American researchers, Wertheimer e Leeper, published for the first time the results of an epidemiological study that demonstrated an increased carcinogenic risk, specifically leukemic, in children residing in close proximity to electric installations and therefore exposed to non-ionizing electromagnetic fields from electrical current at extremely low frequency.

As was to be expected, concern about the possible carcinogenic risks of non-ionizing radiation has now expanded beyond electricity to include other types of non-ionizing radiation, such as electromagnetic fields of radiofrequency and microwaves from cellular telephones and other wireless technologies such as cordless telephones, computers etc.

The expansion of mobile telephone technologies in the last 10 years is without precedent. In 1996 the number of cellular telephones in Italy was circa 4 million, today this figure is estimated to be 40 million. In the US, cellular telephones in the 1990s numbered 9 million, today more than 150 million Americans use cell phones, including children. It is estimated than more than 2 billion people use cell phones worldwide. In addition, many citizens are exposed to electromagnetic fields originating from the antennas of radio base stations that transmit cellular signals. Indeed, exposure to electromagnetic fields of radiofrequency and microwave, in both the work and general environment, has never before experienced this type of growth. For this reason it is fundamentally important to address the issue of safety, using all available tools to evaluate the potential risks of exposure. These tools include both epidemiological and experimental laboratory studies, as well as basic research.

This book provide updated information concerning mechanism of interaction between non ionising radiation fields and living matter, with particular reference to potential non-thermal toxic effects.

The scientific knowledge available today regarding electromagnetic fields remains limited. Nevertheless, on the basis of recent epidemiological studies, and while awaiting new experimental data, it is advisable to limit exposure to electromagnetic fields as much as possible. This is especially true for children and adolescents, the most vulnerable segments of the population, and has been recommended by both the Swedish and UK health authorities.

Why investigate the non thermal mechanisms and effects of electromagnetic fields on living systems?

An introduction

Livio Giuliani

National Institute for Prevention and Safety at Work (ISPESL), Rome, Italy

A Fairy Tale

Protection against Non Ionizing Radiation is based on a paradigmatic assumption: “*We know very well the interaction between electromagnetic fields and living organisms: it is a thermal interaction; thus the standards internationally accepted are adequate to protect people and workers*”¹.

This is a fairy tale.

Since the 1970s the *non thermal* effects of electromagnetic fields on living organisms have been well known and also the *non thermal* mechanisms have been investigated^{2,3}. Nevertheless, until today, we have been condemned to listen to representatives from international institutions repeating the old refrain above. Furthermore when scientists participating in the ICEMS agreed to edit a monograph – the present one - with the aim of illustrating the non thermal mechanisms and effects due to the electromagnetic interaction with living organisms - mechanisms that are well known today - some of us withdrew their contribution because they did not share the locution “*non thermal*” in the title. The following discussion, which many ICEMS scientists and the coauthors of this monograph took part in, focused on some basic points, maybe obvious but not infrequently forgotten.

To be able to speak about a thermal effect on a *system*, we must first observe a variation in the *temperature* of the *system*.

Temperature

In order to define the temperature of a system it is necessary to include the philosophical concept of ensemble: in extension a collection of independent and indistinguishable particles each having a well defined velocity. In such a picture the temperature will emerge as an average property of the system as the average kinetic energy defined on the ensemble. In the case of a biochemical system made up of many *non*-independent particles the very basic concept of temperature has to be defined through an oversimplification of the system description (useful in most applications): we assume that each molecule can be labelled with a mean velocity energy which, in turn, defines an average energy associated with each degree of freedom of the molecule itself. In such

Address: Livio Giuliani, ICEMS Spokesman, National Institute for Prevention and Safety at Work (ISPESL), Via Urbana 167, 00184 Rome, Italy – Tel. +39 06 4714244 – Fax +39 06 4744017 – E-mail: giuliani.livio@gmail.com

a picture a perturbation is termed “thermal” if it is able to change the average kinetic energy associated to each degree of freedom, in such a way that the average of the energies on the ensemble is changed.

The rotating motion of water molecules induced by microwaves is the most evident achievement of such a thermal effect, but we need not think it is unique. In our monograph we focus on an effect – the coupling of RF/MW with cancerous tissues – discovered by E.H. Frick and S. Morse (1924) and re-discovered by C. Vedruccio, as reported in this monograph.

The Energy transfer mechanism described by the classical or semi-classical model of biological matter is based on “hopping” along discrete energy levels. However, as is widely known in the literature, such a model cannot account for the energy transfer process in biological systems such as photo-synthesis, where the light-absorbing molecules can funnel energy with a near-unit quantum efficiency across mesoscopic distances. Such a conundrum implies a deeper re-thinking of the molecular biology model based upon independent and indistinguishable particles. The solution implies a high degree of correlation among a great number of molecules and the entry in play of quantum phenomena. Quantum mechanics teaches us that energy transfer can happen in a quantum-correlated system without entailing kinetic knocks.

Non Thermal effects

In such a picture it is paramount to distinguish between “thermal” and “non-thermal” effects. In fact, the existence of the latter implies a model of biological matter well beyond the classical or semi-classical representation. Hence the deep meaning of the thermal-non thermal *querelle* : to minimize this distinction could lead us to underestimate what is probably the watershed of modern biology.

However, because we are concerned with biology or biophysics - not atomic physics - we may be focused on much more complex systems than atoms and we may fail to monitor the variation of energy of single electrons or single atoms. Even an aqueous solution of aminoacids, in a quantity such as in the electrolytic cell of Zhadin described in this monograph, has millions of billions of billions of molecules, as Avogadro taught us. Thus we should not be deceived by the fact that a certain molecule receives energy during a reaction into concluding that this reaction is based on a thermal mechanism of interaction. We must look at the temperature of the system. We must observe the system and the average of the energies of all components involved.

For instance, in the aqueous solution of the Zhadin experiment, we witness an ion current peak - that can be detected in the order of 10-100 nA - when we apply a suitable combination of DC-AC magnetic fields. But the AC field is very weak: in the order of 10nT! And the DC field is like the geomagnetic one: there is no transfer of energy able to induce an alteration in the system temperature. It is not only a non thermal effect; it is an *athermal* effect!

Thermal/Non thermal in EMF risk assessment

Lastly, let us consider the current meaning of ‘thermal effects’ in RF/MW risk assessment. According to ANSI (1981), interactions inducing a temperature increase lower

than 0.5 °C in the human body are commonly accepted, even by the WHO. The corresponding value in terms of of WHOLE BODY AVERAGE SPECIFIC ABSORPTION RATE (WBASAR) is 4 W/kg. Furthermore, the absorption of 0.4 W/kg – corresponding to a temperature increase equal to a 0.05°C in the body – is considered negligible for workers and the absorption of 0.08 W/kg – corresponding to a 0.01 °C increase – seems to be negligible. WHO, IEEE and ICNIRP assure us that under such a threshold we can be protected against all health effects due to RF/MWs. On this view, biological non thermal effects are only to be considered as reversible effects. But non-reversible effects are detected under the same threshold by epidemiologists –see the assay by Lennart Hardell in this monograph -: such effects can be considered ‘*non thermal*’ effects in this context. What about mechanisms inducing temperature increases lower than 0.001 °C (corresponding to 0.008 W/kg SAR)? They can be considered ‘*non thermal*’ in the same context, in accordance with the usual convention that perturbation of a system, when the parameters are lower by three orders of magnitude than the corresponding parameters of the system, can be considered not related to such parameters.

Perhaps we should specify the meaning of the terms thermal/non thermal in the present monograph. With reference to the usual meaning adopted in the context of *protection against radiation*, we can consider as *non thermal* all mechanisms that are not able to induce an increase in temperature higher than 0.01°C, when we are considering a system like a living organism, or lower than 0.001 °C when a system like a cell is considered, or again lower than 0.0005 °C when a sub-cellular system is studied.

Several mechanisms and effects are considered in this monograph with the collaboration of many scientists who have joined this ICEMS initiative.

Our book does also include thermal mechanisms and effects as well as macroscopic phenomena (see the various sections of the book).

The point is, *protection against non ionizing radiation*, based on parameters adopted by international standards organizations, seems not to be adequate, despite the statement of Ms Van Deventer, nor able to protect people and workers. This is convincingly shown in the paper by Devra Davis, Om Ghandi and colleagues in this monograph.

Acknowledgment

The author is very grateful to Dr. Antonella De Ninno for her precious suggestions about the vexata quaestio thermal/non thermal

References

1. Van Deventer E. Lecture at Santé et radiofréquence, 1^{ères} Rencontres scientifiques, Paris 2007.
2. Bawin SM, Adey WR. Sensitivity of calcium binding in cerebral tissue to weak environmental electric fields oscillating at low frequency. Proc Natl Acad Sci USA 1976; 73(6): 1999-2003.
3. Van Zandt LL. Resonant interactions between biological molecules. J Biol Physics 1977; 6(3-4): 124-32.

On mechanism of combined extremely weak magnetic field action on aqueous solution of amino acid

Mikhail Zhadin

Institute of Cell Biophysics of RAS, 142290 Moscow Region, Pushchino, Russia

Abstract

The fundamental Physical mechanisms of the resonant action of an extremely weak (40 *nanoT*) alternating magnetic field at the cyclotron frequency combined with a weak (40 *mcT*) static magnetic field, on living systems are analyzed in the present article. The experimental effects of such sort of magnetic fields were described in different articles: the very narrow resonant peaks in electrical conductivity of the aqueous solutions in the *in vitro* experiments and the Biomedical *in vivo* effects on living animals of magnetic fields with frequencies tuned to some amino acids. The existing experimental *in vitro* data had a good repeatability in different laboratories and countries. Unfortunately, for free ions such sort of effects are absolutely impossible because the dimensions of an ion rotation radius should be measured by meters at room temperature and at very low static magnetic fields used in all the above experiments. Even for bound ions these effects should be also absolutely impossible from the positions of Classic Physics because of rather high viscosity of biological liquid media. Only modern Quantum ElectroDynamics of condensed media opens the new ways for solving these problems. The proposed article is devoted to detailed analysis of Quantum mechanisms of these effects.

Key words: extremely weak magnetic fields, aqueous solution, amino acids, cyclotron resonance, coherence domain

Introduction

About 25 years ago Profs Abraham Liboff¹ and Carl Blackman² in the USA discovered that weak (several tens of *mcT*) combined alternating and static magnetic fields resonantly affect different biological objects when the alternating magnetic field frequency was equal to the cyclotron frequency of some biologically active metal (calcium, potassium, magnesium) ions. The cyclotron frequency is determined by the following way:

$$v_{CF} = \frac{qB_s}{2\pi m}, \quad (1)$$

where q is an ion charge, m is its mass, and B_s is the static magnetic field. After some

Address: Mikhail Zhadin, Institute of Cell Biophysics of RAS, 142290 Moscow Region, Pushchino, Russia
- E-mail: zhadin@online.stack.net

discussions and theoretical analysis^{1,2} it was accepted that such sort of effect is impossible for free ions, because the dimensions of an ion rotation radius should be measured by meters at room temperature and at very low static magnetic fields used in all the above experiments. But they could arise for ions bound in molecules³⁻⁶.

However, in 90s after discovering^{7,8} the resonant effects in aqueous solutions of alpha amino acids the situation became much more complicated. The static magnetic field was of 40 *mcT*, which is close to the natural geomagnetic field as earlier, but the alternating magnetic field of about 40 *nanoT* was thousand times less than in Liboff's^{1,9} and Blackman's² experiments. The two difficulties befogged the understanding of Physical mechanisms of these effects. The first one was the fact that in this case the ions were free, and the second one was connected with that the alternating field was thousand times less than in Liboff's effect¹, not counting even the fact that amino acids are not metals at all. The editorial staff of Bioelectromagnetics journal firstly delayed the publication of our submitted manuscript and asked to give some kind of Physical explanation of such unusual effect. This theoretical analysis was given by us four years later, when we pointed that similar effect could arise in solutions containing microcrystals of dissolved matter. But situation with the extremely weak alternating magnetic field nevertheless stayed unclear. Fortunately, both our articles^{8,10}, experimental and theoretical ones, were published^{5,8} in this journal. Later, our experiments were successfully replicated in Italy¹¹⁻¹³ and in Germany¹⁴, and now the different articles appeared in international scientific press¹⁵⁻¹⁷ [and others], which were experimentally developing the investigations of Biological effects of the extremely weak alternating magnetic fields *in vivo* on animals. However, till 2002 an obstacle in understanding such sort of the ionic cyclotron resonance effect remained insuperable. It was the impossibility of essential acceleration of an ion at the real viscosity of an aqueous solution under the influence of extremely weak combined magnetic fields. The Classical Physics was giving the well defined negative answer to the possibility of such effect. This problem was solved by Quantum ElectroDynamics of condensed matter.

Physical mechanisms of extremely weak combined magnetic fields action

At the end of 20th century in the famous Institute of Nuclear Physics (Italy) Prof. Giuliano Preparata and his colleagues elaborated a new branch of Quantum ElectroDynamics – the theory of condensed matter¹⁸⁻²¹. Among different liquid media the specific attention was drawn to water with its multitude of unsolved problems which now are successfully solved by this new branch of Quantum Physics. Quantum ElectroDynamics of water convincingly evidenced that the liquid water consists of two components: coherent and incoherent ones. The coherent component is contained within spherical structures, the so called “coherence domains”, where all molecules have the wave functions, oscillating synchronously with the same mutual phase. Coherence domains are surrounded by the incoherent component where the molecular wave functions are oscillating with casual phases relative to each other. As a matter of fact, the incoherent component is the water from the point of view of Classical Physics. Diameters of coherence domains are measured by tenths of a micron, and at room temperature the total volume of the domains is about 40% of the whole water volume. Within a domain, the features of coherent water sharply differ from ones of incoherent water and from the water as a whole. Within domains the water viscosity and oscillation

damping are about ten times less than viscosity and damping in the whole water. The fluidity in the domain is essentially increased, and the diffusion rate of foreign inclusions is much higher than within the incoherent water. The theoretical estimates of all electrical constants of the whole water, being earlier inexplicable by Classical Physics, for the first time turned out to be close to the experimental values, being analyzed by Quantum ElectroDynamics of water. And the unusual dependence of water density on temperature was explained too. The stability of coherence domains is rather high, because the bond energy of water molecules within coherence domains is much more than the thermal noise energy.

In our recent work²² we considered the amino acid ionic exchange between incoherent medium and coherence domains (using a glutamic acid ion as an example) under the influence of weak combined magnetic fields. (In this work we name the aqueous coherence domain containing one or more foreign molecules or ions as a “mixed domain” for brevity. We’ll use this term further for the same purpose). In the above article we studied the formation of mixed coherence domains in aqueous solutions of some amino acids and revealed the mechanisms of capture of some amino acid ions in zwitterion forms. Far from all soluble matters are able to form the mixed domains, but only ones which have the main spectral lines, common with the lines in water spectrum. In the present article we’ll analyze in detail the mechanism of escape of amino acid ion from the mixed coherence domains under the action of resonant combined magnetic fields.

In our analysis of magnetic field effect on ion motion within coherence domains we shall consider the domain wall without traditional easy-to-use approximation of a vertical potential well because the resonant increase in kinetic energy of an ion is impossible at this very rough approximation. Here we shall consider the domain wall as a layer with the finite thickness, in the range of which the density and viscosity have the same values as within the whole domain. Earlier we⁵ derived, analyzed and solved the equation of the ion motion in the centrally symmetric potential field under the influence of parallel combined static and alternating magnetic fields. Here we’ll use some important achievements of the above work. The equation will have the following form:

$$\frac{d^2 \mathbf{r}_o}{dt^2} = -\gamma \frac{d\mathbf{r}_o}{dt} - \omega_o^2 \mathbf{r}_o + \frac{q}{m} \left[\frac{d\mathbf{r}_o}{dt} \times \mathbf{B} \right] + \frac{q}{2m} \left[\mathbf{r}_o \times \frac{d\mathbf{B}}{dt} \right] + \mathbf{F} \quad (2)$$

The equation (2) is given in the vector form. Here is the radius-vector of the ion position originating at the equilibrium point of the ion; t is the time; q and m are the charge and mass of the ion; \mathbf{B} is the total static and alternating magnetic fields; γ is the damping coefficient inhibiting ion circulation around the center ω_o ; is the natural frequency of the ion oscillation in a coherence domain; \mathbf{F} is the total force of an action of surrounding particles on the ion that causes the thermal motion of the ion near its equilibrium point; the bold letters denote vectors; the square brackets symbolize vector products. On the left the general form of a potential well inside a coherence domain is shown. On the right the first term takes into account the passive friction, and the second one is determined by the force of the intradomain potential field restoring the ion to its equilibrium point; the third term is the Lorentz force of the magnetic field action on the moving ion which manifests itself in the rotation of the trajectory of the ion thermal motion around the magnetic field line; the fourth one results from the force made by the curl

field generated by the time-varying magnetic field. In the following, we considered the parallel magnetic fields algebraically summed: the static field, \mathbf{B}_0 , and the alternating field, \mathbf{B}_{AC} , harmonically varying.

On fig. 1A the drawing of the approximate form of the potential well inside a coherent domain is shown. In the center of a domain the potential slowly nonlinearly increases, step by step enlarging the rate of its rise. Within the peripheral region (between two vertical dotted lines R_i and R_e) its rising becomes especially sharp – it is the before mentioned domain border of finite thickness. In the area with $R_e > R_i$ the incoherent medium is located. On the right-hand the drawing of the coherence domain is shown, where the incoherent component outside the coherence domain border is shown too.

When the combined magnetic fields with a cyclotron frequency, corresponding to dissolved amino acid, become switched on, the dissolved amino acid ions can be located in arbitrary points, others than the domain center. All these ions started their comparatively slow rotation around different centers, other than the domain center. But these centers will begin to slide automatically step-by-step toward the domain center, because the minimal potential energy is located there. In some time, all the amino acid ions will gather on concentric orbits around domain center, forming the stable configuration with minimal potential energy. After that they become their rotation along the concentric orbits inside the domain, increasing their kinetic energy. It is rather effective because it will be not only due to the increase in the radius elongation, but especially because the kinetic energy will be especially grow within the high potential gradient in the layer $R_e > R_i$ of high nonlinearity in its potential growth. The group of ions leaves the coherence domain at the border R_i and enters into the incoherent medium, creating its contribution into formation of the prominent peak of the current through the solution. The viscosity of the coherent water inside the domains is about an order lower than in the incoherent media. It permits to increase the ion energy (which is proportional to squared ion velocity) to one or even two orders that is quite enough for leaving the ion from the domain. These processes would not practically influence on the total temperature of the domain and the total solution because of low mass of the total amino acid ions compared to the total mass of the surrounding water. Of course, the effectiveness of such sort of accelerator is extremely low, but it is quite enough for ion leaving a domain.

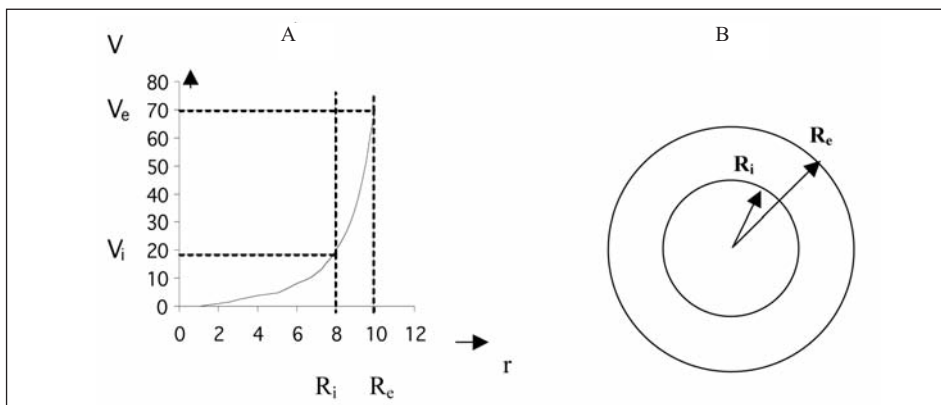

Fig. 1. A) The general form of a potential well inside a coherence domain. B) The coherence domain with the part of incoherent component $R_e > R_i$ area are shown. (Details are explained in the text of this article)

References

1. Liboff AR. Geomagnetic cyclotron resonance in living cells. *J Biol Phys* 1985; 9: 99-102.
2. Blackman CF, Benane SG, House DE, *et al.* Effects of ELF (1-120 Hz) and modulated (50 Hz) RF fields on the efflux of calcium ions from brain tissue in vitro. *Bioelectromagnetics* 1985; 6: 1-11.
3. Lednev VV. Possible mechanism for the influence of weak magnetic fields on biological systems. *Bioelectromagnetics* 1991;12: 71-5.
4. Zhadin MN. Effect of magnetic fields on the motion of an ion in a macromolecule: Theoretical analysis. *Biophysics* 1996; 41, 4: 843-60 (in Russian).
5. Zhadin MN. Combined action of static and alternating magnetic fields on ion motion in a macromolecule: Theoretical aspects. *Bioelectromagnetics* 1998; 19: 279-92.
6. Zhadin M, Barnes F. Frequency and amplitude windows at combined action of DC and low frequency AC magnetic fields on ion thermal motion in a macromolecule: Theoretical analysis. *Bioelectromagnetics* 2005; 26: 323-30.
7. Novikov VV, Zhadin MN. Combined action of weak constant and variable low-frequency magnetic fields on ionic currents in aqueous solutions of amino acids. *Biophysics* 1994; 39, 1: 41-5 (in Russian).
8. Zhadin MN, Novikov VV, Barnes FS, *et al.* Combined action of static and alternating magnetic fields on ionic current in aqueous glutamic acid solution. *Bioelectromagnetics* 1998; 19: 41-9.
9. Liboff AR, Smith SD, McLeod BR. Experimental evidence for 104 cyclotron resonance mediation of membrane transport. In: Blank M, Findl E, eds. *Mechanistic Approaches to Interaction of Electric and Electromagnetic Fields with Living Systems*. New York: Plenum Press, 1987; 109-32.
10. Zhadin M. Combined action of static and alternating magnetic fields on ion motion in a macromolecule: theoretical aspects. *Bioelectromagnetics* 1998; 19: 279-92.
11. Del Giudice E, Fleischmann M, Preparata G, *et al.* On the “unreasonable” effects of ELF magnetic fields upon a system of ions. *Bioelectromagnetics* 2002; 23: 522-30.
12. Comisso N, Del Giudice E, De Ninno A, *et al.* Dynamics of the ion cyclotron resonance effect on amino acids adsorbed at the interfaces. *Bioelectromagnetics* 2006; 27: 16-25.
13. Giuliani L, Grimaldi S, Lisi A, *et al.* Action of combined magnetic fields on aqueous solution of glutamic acid: the further development of investigations. *Biomagnetic Res Technol* 2008; 6:1.
14. Pazur A. Characterization of weak magnetic field effects in an aqueous glutamic acid solution by nonlinear dielectric spectroscopy and voltammetry. *Biomagnetic Res Technol* 2004; 2: 8.
15. Bobkova NV, Novikov VV, Medvinskaya NI, *et al.* Decrease of the level of amyloid in the brain under the influence of weak combined magnetic fields on the model of sporadic form of Alzheimer disease. *Biophysics* 2005; Suppl. 1: S2-S7 (in Russian).
16. Bobkova NV, Novikov VV, Medvinskaya NI, *et al.* The weak combined magnetic fields reduce the brain 739464-amyloid in an animal model of sporadic Alzheimer’s disease. *PIERS Online* 2009; 5, 4: 311-5.
17. Seyhan N, Giuliani L, Canseven A, *et al.* Exposing pregnant and newborn rabbits to Ca⁺⁺ and MG⁺⁺ cyclotron frequency magnetic fields. *Open Education* 2008; Suppl: 306-8.
18. Preparata G. *QED Coherence in Matter*. Singapore - New Jersey - London - Hong Kong: World Scientific, 1995.
19. Preparata G. QED and Medicine. *Rivista di Biologia 2000/Biology Forum* 1993: 467-512.
20. Del Giudice E, Preparata G. A new QED picture of water. In: Sassaroli E, Srivastava YN, Swain J, Widom AB, eds. *Macroscopic Quantum Coherence*. Singapore: World Scientific, 1998.
21. Del Giudice E, Preparata G, Fleischmann M. QED coherence and electrolyte solutions. *J. Electroanalytic Chem* 2002; 482: 110-6.
22. Zhadin M, Giuliani L. Some problems in modern Bioelectromagnetics. *Electromagnetic Biol Med* 2006; 25 (4): 227-43.

Coherence in water and the kT problem in living matter

Emilio Del Giudice*, **, ***, Livio Giuliani*, ****

* International Commission for Electromagnetic Safety, Venice, Italy

** National Institute for Nuclear Physics (INFN), Milan, Italy

*** International Institute of Biophysics (IIB), Neuss, Germany

**** National Institute for Prevention and Safety at Work (ISPESL), Rome, Italy

Abstract

Albert Szent-Gyorgyi stated that scientists cannot formally distinguish between *animate* and *inanimate* things possibly because biological science concentrated on studying substances typical for living things and neglected two matrices without which they cannot perform anything: water and electromagnetic fields¹. As a matter of fact water represents 70% of the total mass and 99% of the molecules in average living organisms, so that it is conceivable that it should play an important role in the dynamics of the alive. Since the single water molecule is too simple, as compared to the structure of the other biomolecules, it is unreasonable to think that it could play a role as a single independent object. The only possibility is that such a role could be played by the supramolecular organization of a large number of water molecules. Collective properties of water are thus the main topics to be investigated in a biological context. Since the long range interaction among molecules cannot be but electromagnetic, the long range organization of water molecules requires the essential intervention of the electromagnetic field. A theory of the organization of liquid water in the framework of Quantum Electrodynamics has been worked out in the last two decades. It has been shown that in the liquid state water self-organizes and produces extended regions (coherence domains, CD) where the component molecules behave in unison, having the phase locked with the phase of a self-trapped electromagnetic field. It is therefore conceivable that externally applied electromagnetic fields should have the collective organization of water as their primary target and they are able to affect the other biomolecules through the mediation of water. Water is able to constrain the behaviour of biomolecules in such a way that they would not follow anymore a diffusion dynamics. Biomolecules would be governed by Electromagnetic field (EMF) originated by the coherent structure of water. The replacement of the diffusive dynamics by a field driven dynamics allows the arising of ion currents in a living environment which are no longer subjected to the constraints of the thermal noise. As a consequence these currents could be affected by applied EMF much weaker than those allowed according to the kT threshold.

Address: Livio Giuliani, National Institute for Prevention and Safety at Work (ISPESL), Rome, Italy -
E-mail: giuliani.livio@gmail.com

Such an approach is discussed in the present paper in the particular case of electrolytes and is shown that the action of very low frequency magnetic fields on ions can be accounted for by introducing their effect on the dynamics of water. In this frame the so called *Zhadin effect* assumes a meaning as a probe of the inner structure of water as it is governed by electromagnetic fields.

***Key words:* quantum electrodynamics, quantum field theory, ion cyclotron resonance, non-thermal mechanisms of electromagnetic bio-interaction, electromagnetic therapy, coherence in living matter**

Introduction

Living organisms generally are complex systems where a huge number of molecular species interact within a large amount of water. All these components have, in these conditions, configurations quite different from the one assumed when they are isolated.

As far back as 1957 Albert Szent-Gyorgyi said that biologists were still unable to provide a formal definition of “animated matter” since they limited themselves to study biomolecules to the neglect of the two matrices without which biomolecules cannot perform any functions: water and electromagnetic fields.

As a matter of fact, by the middle of the last century it has been recognized that a thick layer of “*special water*” appears on hydrophilic surfaces reaching a depth of several hundreds of microns². The same result has been reproduced quite recently in much more detailed way by the group led by Pollack³.

Since living matter is a dense assembly of macromolecules embedded in water, the ensemble of biomolecules constitutes a huge surface area hydrated by water, so that we can safely assume that biological water would assume the same properties of the “special water” existing near the hydrophilic surfaces. Consequently physical-chemical processes going on in living matter should be considered quite different from those occurring in diluted solutions⁴.

The main properties of *this “special water”*, named EZ water, are³:

- a) EZ water excludes solutes; hence the name Exclusion Zone (EZ) for the region occupied by such water;
- b) its viscosity is higher than viscosity of normal water;
- c) it is an electron-donor, namely a reducer, whereas normal water is a mild oxidant: consequently the interface EZ-water/normal water is a redox pile, where the redox potential could have a jump of a fraction of a Volt;
- d) EZ water exhibits a fluorescent response in the UV region at 2700 Å.

The property c) of the above list has been recognized in 1956 by Szent-Gyorgyi⁵, who discovered an exceptionally long living state of electronic excitation of the different molecular species interacting with the ordered water. He suggested that the above property is at the origin of the energy transfer in biological systems explaining how the energy bound in biomolecules can be transformed into free energy able to perform useful work. Following this line of thought, he defined life as the dynamics occurring between two levels of the electron clouds of water molecules: an excited state and a ground state. It is just this electron dynamics at the origin of the singular redox properties found in the water in living matter.

In this conceptual frame life can be seen as a little electric current going round and round.

It is apparent that here electromagnetic fields find a place within the biological dynamics. Electromagnetic fields are just able to couple with the current of electron excitation producing important consequences on the biochemistry which is just governed by this electron excitation.

In the present contribution we will examine the dynamics sketched above in the frame of Quantum Electrodynamics (QED^{6,7}). We will use the particular phenomenon discovered by Zhadin and co-workers^{8,9}, concerning the interaction of weak magnetic fields with ion currents as a probe to test the QED concepts. This phenomenon provides an example of non thermal interaction between electromagnetic field and living matter.

Water is a quantum liquid

The EZ properties, discovered in the last half century, can be hardly understood in the conceptual framework of electrostatic (ES) interactions used so far to analyze intermolecular dynamics. In the ES approach, the interaction is conceived to occur via static potentials introduced *ad hoc* to account for the observed properties¹⁰. In the ES interaction the mutual excitation of molecules has no chances of reaching the very high level of energy – 12.60 eV! - necessary to extract an electron from a water molecule. The observed phenomenon of the acquisition by water of a reducing capability is therefore incompatible with the ES conventional approaches to water. We need a more robust interaction which cannot arise from a pair-wise interaction but demands a collective dynamics involving a large number of molecules.

QED provides a clue to solve this problem. We will summarize now the QED approach to water, following the lines of reference¹¹.

An ensemble of molecules, for instance water molecules, can enter in an oscillatory dynamics between two internal configurations of theirs picking up the necessary transition energy from the ambient electromagnetic background, in particular the quantum vacuum.

Molecules have a size of some Angstroms, whereas a typical transition energy between different internal configurations has an order of magnitude of a few eV: in the case of water, 12 eV. The typical size of the supplier of such energy, namely a photon, is just the photon wavelength, connected to energy E by the equation

$$\lambda = hc/E \quad (1)$$

where h is the Planck's constant and c the speed of light.

For $E= 12$ eV, we get $\lambda = 1000$ Å. Namely the photon has a size one thousand times larger than the molecule it is going to excite!

Should the molecule density be large enough the exciting photons would cover simultaneously many molecules, giving rise therefore to a collective process?

Let us describe the process in more detail.

The photon excites a first molecule, which after a time – the lifetime of the excited level – decays releasing back the photon, which has two options: either return back to the ambient background or excite a second molecule.

Let us call P the probability of excitation of one molecule by the photon and N the number of molecules present within the volume $V=\lambda^3$ occupied by the photon.

When the molecule density $n=N/V$ matches or overcomes the critical threshold $n_{crit}=N/V_{crit}$ such that:

$$P\lambda^3 n_{crit}=1 \quad (2)$$

the photon has no chance of coming back to the ambient background and keeps permanently trapped in the ensemble of molecules. The same fate occurs to the other photons coming out of the ambient background, so that in a very short time a large electromagnetic field grows within the molecule ensemble being trapped into the volume V which from now on we will refer to as Coherence Domain (CD). According to a general theorem of Electrodynamics, the other molecules passing by near the CD are attracted by resonance within it producing the huge increase of density actually observed in the vapour-liquid transition. This increase of density ends when the hard cores of molecules reach a close contact. This saturation value of density coincides with the observed density of the liquid, which in the case of water is 1600 times higher than the vapour density. According to the mathematical treatment in reference¹¹, the above dynamics produces a CD where the component molecules oscillate permanently between the molecule electron ground state and the electron excited state at 12.06 eV, a level lower the ionization level by half an eV only. Moreover an electromagnetic field is permanently trapped within the CD; this field has a frequency which in energy units is 26 eV, i.e. 6.5×10^{13} Hz, whereas its wavelength is 1000 Å. According to a general property of quantum field theory, the frequency of such field is much lower than the frequency of the free field having the same wavelength; the frequency of the free field would be actually 48 times larger. This renormalization of the frequency of the field is the element producing its self-trapping; this renormalization eliminates the actual distinction within the CD of matter and field. We get actually an intimate mixture of both matter and field, that could be called energized matter. We remind that at the end of 19th century the German botanist Julius Sachs¹² coined the term “energid” namely energized matter, to denote the substance constituting living organisms.

We can understand better the self-trapping mechanism by referring to the relativistic definition of the mass m of a particle. We have actually

$$m^2 = E^2 - c^2p^2 = h^2 (v^2 - c^2/\lambda^2) \quad (3)$$

where p is the momentum and v the frequency.

In the free field case

$$v = c/\lambda \quad (4),$$

so that the free photon has a zero mass, as well known. In the CD we have seen that

$$v^2 - c^2/\lambda^2 < 0 \quad (5)$$

so that the CD photon has a negative squared mass, i.e. an imaginary mass. This means that it cannot propagate as a particle and appears in the form of the CD cohesion energy.

Let us consider the energetics of the CD.

According to the quoted reference¹¹ a component water molecule of the CD finds itself in a superposition of the ground state with a weight 0.87 and a state excited at 12.06

eV, having a weight 0.13. Correspondingly the average excitation energy of the component molecule is 1.53 eV, whereas the trapped electromagnetic field requires an energy of 3.55 eV per molecule. However the interaction energy between the trapped electromagnetic field and the electric current produced by the oscillation of the molecule electron cloud gives rise to a negative value of -5.34 eV, producing a net balance of -0.26 eV per molecule, which correspond also to the frequency of collective coherent oscillation of all the molecules in unison within the CD. In this way the onset of electrodynamic coherence corresponds to a lowering of the total energy and simultaneously to a lowering of its entropy since coherence prescribes a common motion to all molecules, curtailing sharply the number of microstates, whose logarithm is just proportional to entropy.

The above theory applies to all molecular species, but the case of water is peculiar since the excited state involved in the coherent oscillation lies just below the ionization threshold. The coherent oscillation produces therefore in its own high energy limit an almost free electron per molecule. Considering the complete oscillation we get 0.13 almost free electrons per molecule. Since in a single CD we have at room temperature 5.5 millions of molecules, we have permanently about 700,000 almost free electrons.

Let us now address the dependence of this dynamics upon temperature T . The electrodynamic attraction discussed so far is perturbed by the collisions with particles external to CD, whose number and violence depend just on T and on pressure P .

Let us keep P constant. It is possible¹¹ to calculate for each temperature the fraction of molecules pushed out of tune by the collisions. In this way we get a two phase picture of water: a coherent phase having a constant density 0.92 (the density of ice) whose fraction decreases with temperature and a non coherent, gas like, phase squeezed in the interstices among the CDs, whose density decreases with temperature and whose fraction increases with it.

Given the flickering character of collisions the space structure of the two phase system is flickering also, so that a measurement having a resolution time large enough would find an average homogeneous situation. Only measurements with a very short resolution time (of the order of the collision time, 10^{-10} s) would detect the two phase structure. As a matter of fact a very recent X-ray small angle investigation¹³ has found evidence of the presence of two liquids having different densities in normal bulk water: the first one, having a larger viscosity, formed by microstructures, the second one, having a lower viscosity, formed by non bounded molecules. Although this experiment is able to detect the existence of the density fluctuations does not seem to be able to reveal the real size of the aggregates which would appear only on an instant snapshot. A finite resolution time allows to detect only the aggregates living longer whereas would ignore the aggregates living a shorter time. Evidence of the presence of larger aggregates in aqueous solutions, which could be traced back to the QED predictions, have been presented in a recent paper by Yinnon & Yinnon¹⁴.

The above considerations apply to bulk water.

Near a hydrophilic surface or in any situation where the disruptive effect of collisions is somehow reduced, the CDs become much more stable, so that they are able to exhibit for a long time their typical properties. It is intriguing to realize the coincidence of the predicted properties of CDs with the observed properties of EZ water.

In a CD water molecules are kept closely packed by the self-trapped electromagnetic field, which excludes the non resonating particles. Thus the solutes are expelled from within the CD; in particular molecules of the atmospheric gases, that are always present

in water, are excluded from within the CD and form micro bubbles aside. In bulk water, where the CD network is flickering, the array of micro bubbles is flickering too, as confirmed by experimental observation. On the contrary when the array of CDs gets stabilized, a stable network of micro bubbles appears. This occurs in those “special waters” where the coherent network is stabilized by special procedures (dissemination of inert microspheres, irradiation by microwaves and so on); this is the case of so called “neowater”, described in the literature¹⁵. The appearance of a stable network of micro bubbles coincides with the appearance of the order in treated water.

It is interesting that a stable network of micro bubbles, having a size comparable to that of CDs (100 nm), appears also in an aqueous structure dynamically created long ago¹⁶, the so called “floating water bridge”, recently produced applying very high voltages (15 kV or more) to neighbouring beakers filled with pure water¹⁷. The liquid constituting the water bridge has been shown to exhibit an internal order^{18,19} comparable to that of “neowater” and other “special waters”²⁰.

The peculiar redox properties observed in EZ interfacial water find an obvious explanation in the large amount of almost free electrons available in CDs.

A particle of electric charge q and mass m in presence of an electromagnetic field whose vector potential is

$$A = a(x) \exp(i\omega t) + a(x) \exp(-i\omega t) \quad (6)$$

is acted upon by the so called *ponderomotive* force:

$$F_p = -q^2/(2m) \text{grad} |A|^2 = q V_p \quad (7)$$

Equation (7) can be easily understood by writing the Hamiltonian for a particle with momentum p embedded in a field A :

$$H = (p + qA)^2 / (2m) \quad (8)$$

which gives rise to the field energy distribution

$$U = q^2 / (2m) |A|^2 \quad (9)$$

whose gradient is just the *ponderomotive* force in (7).

Since there is an electromagnetic field trapped within the CD, $\text{grad} |A|^2$ acquires a large value on the outer mantle. Thus the *ponderomotive* force, which is inversely proportional to the mass of the particle acted upon, pushes outwards the CD electrons much more than nuclei. As a consequence a double layer of electric charge appears on the CD boundary producing a capacity per unit area of 20 $\mu\text{F}/\text{cm}^2$ and a difference of electric potential of about 100 mV²⁷. In the double layer the negative charge is outwards. In this way the CD is able to transfer electrons outwards quite easily.

The QED scheme accounts also for the higher viscosity of EZ water. As a matter of fact the coherent fraction of water approaches the unity when temperature approaches 2000 K, where water enters into a glassy state, i.e. purely coherent water looks like a glass²². Recently it has been reported that a glass transition is very likely to occur within compressed cells²³. Since we know that water is the main component of cell matter one could presume that cell water, being a totally interfacial water, should be almost totally

coherent. As said in reference²⁴: "interfacial and intracellular water is directly involved in the formation of amorphous matrices, with glass-like structural and dynamical properties. We propose that this glassiness of water, geometrically confined by the presence of solid intracellular surfaces, is a key characteristic that has been exploited by Nature in setting up a mechanism able to match the quite different time scales of protein and solvent dynamics, namely to slow down fast solvent dynamics to make it overlap with the much slower protein turnover times in order to sustain biological functions. Additionally and equally important, the same mechanism can be used to completely stop or slow down biological processes, as a protection against extreme conditions such as low temperature or dehydration".

The formation of a coherent region much more extended than the single CDs (some hundreds of microns vs 0.1 micron) is the consequence of an additional coherent dynamics which emerges in presence of external electric polarization fields, such as those produced by hydrophilic surfaces²⁵. In this kind of coherence the coupled states are the rotational states of the water molecules that produce a coherent oscillation on a range of more than 400 microns but producing a very small energy gain. Consequently this coherence does not contribute significantly to the water cohesion but is able to tune together the smaller CDs. A consequence of this coherence is the emergence in the interfacial water of a permanent electric polarization field which has been actually observed in living organisms²⁶.

Water and electrodynamics in living organisms

The organization of liquid water induced by the electrodynamic interaction and stabilized by the hydrated surfaces satisfies the requirements proposed by Szent-Gyorgyi half a century ago¹. The organized water fulfils three main functions:

- 1) it governs the encounters among molecules through a resonance mechanism;
- 2) it stores low grade (high entropy) energy picked up in the environment, transforming it in to high grade (low entropy) energy, able to produce electron excitations of biomolecules;
- 3) it is able to release electrons as a consequence of very tiny excitations, so making the CDs a catalyst for redox biochemical reactions.

Let us comment briefly the above statements.

About the first point we wish to recall a fundamental theorem of electrodynamics²⁷ which states that two particles able to oscillate on the same frequency of an electromagnetic field attract mutually inside the region filled by the field. The attractive force is proportional to the gradient of the squared field, so that the surface of the CDs becomes a privileged place where coresonating molecules get strongly attracted and are able to chemically react. The output energy of the reaction is picked up by the CD almost entirely, since the energy transfer via electromagnetic interaction is much faster than the energy transfer via diffusive processes toward the non coherent phase. The energy transfer induces a change in the frequency of the coherent oscillation of the CD giving rise to exchange of the attracted molecular species. Consequently the water CDs are able to catalyze on their surface time dependent sequences of molecule encounters; each step of the sequence is determined by the previous one via the amount of the energy output of the reaction. In this way the emergence of a complex biochemical cycle becomes possible.

About the second point we recall that in each CD there is a reservoir of almost free electrons. A tiny amount of energy assumed by the CD is able to induce a coherent excitation of this reservoir²⁸, which appears as a vortex of electrons, having an angular momentum quantized to integer multiples of h (constant of Planck), and consequently a quantized magnetic moment. In Del Giudice and Preparata²⁸ it has been shown that the life times of these vortices are very long, up to weeks or months. Since Earth has a non vanishing static magnetic field the magnetic moments of the vortices, that are “cold” because of coherence, are aligned. The long life time of the vortices allows to sum up many of them, producing higher and higher excitations in time. Many uncorrelated small excitations produced by an environment having a high entropy are then transformed in an unique excitation, whose entropy is zero and whose energy is the sum of energies of all the component excitations. In this way the water CD is a device able to collect high entropy ambient energy and give rise to a single high energy electron excitation: this mechanism implements²⁹ the thermodynamic requirement for a “*dissipative structure*”, as postulated by Prigogine³⁰.

When the stored energy equals the activation energy of some coresonating molecules it is transferred to them in a resonant way.

About the third point we observe that the CD in its ground state presents an energy barrier for its almost free electrons of about half an eV. The height of this barrier is reduced when the CD is in an excited state, so that a supply of electrons is provided to the resonating molecules together with a supply of energy.

The complex biochemical structure emerges as a consequence of the electrodynamic structure of the water CDs, that can be regarded therefore as the main agents of the self organization of living organisms. Given the basically electromagnetic character of this organization it is not surprising that living organisms are able to interact with external electromagnetic fields in a “*non thermal way*”. The prejudice that the only electromagnetic effect on living organisms be the thermal effect depends on the misconception that a living organism is constituted by independent non coherent molecules. A strong support to the point of view described above is provided by the result recently reported by the Montagnier group³¹: they were able to detect low frequency electromagnetic signals produced by the aqueous structures surrounding the bacterial DNA during the infection process which can be regarded as a period of intense biological activity. Another experimental evidence compatible with the above approach is the finding of Blank and Goodman³²: they have found evidence that electrons, both in DNA and surrounding water “*fluctuate at frequencies that are much higher than the frequencies of the EM fields studied. The characteristics of the fluctuations suggest that the applied EM fields are effectively DC pulses and that interactions extend to microwave frequencies*”. This finding can be understood only assuming that electrons are not tightly bound within their molecules as it occurs when molecules are isolated, confirming that the living system cannot be conceived as an assembly of basically isolated molecules.

In next sections we wish to discuss in detail a different case of interaction of electromagnetic fields with biomolecules, namely the so called Zhadin effect^{8,9}.

The Zhadin effect

In the 1980's two experimental groups reported the surprising results that the application of a very weak alternating magnetic field, aligned with the Earth's magnetic field

produced detectable inflows of selected ions in cells when the frequency of the alternating field matched the ion cyclotron frequency, namely:

$$v = \Omega/(2\pi) = 1/(2\pi)(q/m)B \quad (10)$$

where q and m are the ion charge and mass respectively and B the Earth magnetic field³³⁻³⁵.

In particular, Blackman and co-workers^{33,34} observed a change of calcium ion concentration in the cerebral tissue of chicken that had been previously exposed to an alternating magnetic field (AC MF) in the band of Extremely Low Frequency (ELF). The exposure was performed in laboratory, in presence of the geomagnetic static field (DC MF). Further interpretations of the phenomenon suggested a relationship between the flux of calcium ions within the cerebral tissue and the action of both magnetic fields, the applied artificial AC MF and the natural geomagnetic field³⁴. An ion motion was hypothesized along cyclotron orbits around axis parallel to the geomagnetic field. In such hypothesis the flux of calcium ions would have been due to a resonance effect of the applied artificial AC MF matching the cyclotron frequency of the tested ion species. It seemed to be an effect like an Ion Cyclotron Resonance (ICR)³⁵, although a cyclotron orbit in the ELF band was believed to have a radius in the range of meters.

In the early 1990's at the Institute of Cell Biophysics of Pushchino, in the region of Moscow, Zhadin and co-workers^{8,9} performed a series of experiments to investigate whether weak AC MF, in the band of ELF, combined with parallel DC MF had any effect on aqueous solutions of aminoacids, particularly on aqueous solutions of GLU at pH 2.5. At pH 2.5 GLU is a neutral molecule but it appears to be an electric dipole due to the presence of both COOH^- and NH_2^+ groups. The solution filled an electrolytic cell whose electrodes had a potential difference of 80 mV (fig. 1). This system was selected as the simplest model of a living cell, a sort of electrochemical substitute of a liposome. The aim was to understand whether weak AC magnetic fields, in the presence of geomagnetism, were able to influence such a model system and to estimate the minimal threshold of the alternating magnetic field able to induce an effect. In the experiment they measured a weak electric current passing through the solution (fig. 2).

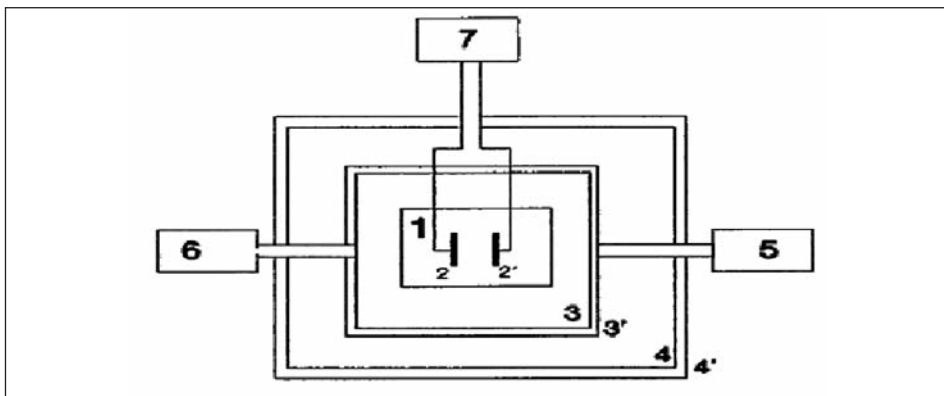

Fig. 1. Experimental installation. 1 - Cuvette with solution. 2 - Electrodes. 3 - Solenoid coils. 4 - Magnetic screen of Permalloy. 5 - Direct voltage source. 6 - Sine-wave generator. 7 - Measuring block: stabilizer of electrode voltage, current meter, recorder

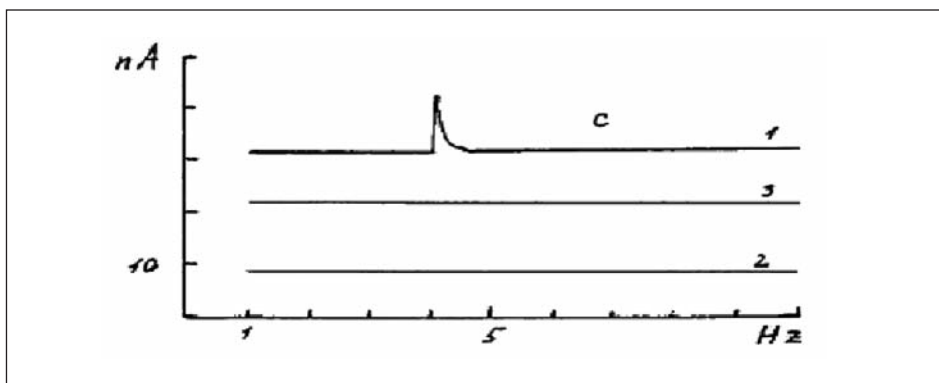

Fig. 2. Ionic current through aqueous glutamic acid (Glu) solution as a function of alternating magnetic field frequency at different values of static magnetic field. The alternating magnetic field frequency in Hz is plotted on the horizontal axis; the ionic current in nA is plotted on the vertical axis. The alternative field amplitude is $0.025 \mu\text{T}$; a static magnetic field $B_0 = 20 \mu\text{T}$; b: $B_0 = 30 \mu\text{T}$; c: $B_0 = 40 \mu\text{T}$; 1: Glu solution with pH = 2.85; 2: Glu solution with pH = 3.2; 3: water with pH 2.85

The experimental equipment was shielded by means of a cover of permalloy to avoid that the geomagnetic field could penetrate in the vessel.

In such a way Zhadin and co-workers were able to test the exact relationship between the intensity of the DC MF – which they artificially produced without any use of the natural geomagnetic field - and the frequency of the AC MF, taking into account that the cyclotron frequency is proportional to the actual intensity of the existing DC MF. If the frequency of the AC MF, able to induce an effect, matched the cyclotron frequency of GLU corresponding to the produced DC MF, then they got the proof that the effect was due just to the cyclotron frequency of the applied AC. The DC MF amplitude was chosen close to the geomagnetic one: 0.04 mT . Several values of AC MF amplitude were tested. For each tested value of AC MF amplitude Zhadin and coworkers scanned the range of frequencies around the proper cyclotron frequency of the ion of GLU. A peak of the current established through the solution appeared when the frequency of the applied AC MF matched the cyclotron frequency of GLU corresponding to the produced artificial DC field (three different DC fields were produced). The peak of efficiency was reached when the intensity of the AC MF was 25 nT , about one thousand times lower than the intensity of the actual DC MF.

Since the applied AC MF was so weak the effect should be necessarily attributed to a non thermal mechanism which is able to generate a peak of current, which could not be explained otherwise.

A surprising effect, connected with the above effect, has been reported by Giuliani, Zhadin and co-workers³⁶. They removed the electrodes from within the cell and applied then outside on the outer walls of the vessel, making it a condenser cell. A voltage was applied analogously to the previous case producing an electric field in the cell. The Zhadin combination of magnetic fields was applied orthogonally to the direction of the electric field. When the frequency of the AC magnetic field matched the GLU cyclotron frequency a very narrow peak of current appeared in the coils of the solenoid producing the magnetic field, suggesting an effect of the applied magnetic fields that was not a molecular effect but an extended field effect.

Discussion of the Zhadin effect

The water-GLU system

The Zhadin system is an aqueous solution of GLU at pH 2.5. GLU is a biomolecule, namely it is able to resonate with the water CDs. The frequency of oscillation of CDs depends on the number of component molecules, which in turn depends on temperature T . At $T=0$ this frequency (in energy units) is 0.26 eV, whereas at room temperature ($T=300$ K) is slightly more than 0.20 eV. A molecule is able to resonate with the CD when the difference between one of its own frequencies and the CD frequency is less than the thermal noise kT , which at room temperature is 0.025 eV. Consequently a molecule can resonate with the water CD when its spectrum contains at least one line in the interval (0.20 ± 0.025) eV. GLU has a line in this range³⁷. The attracted GLU molecules settle in the outer mantle of CDs where they align their electric dipoles to the radial direction and are subjected to the “ponderomotive” force defined in equation (7). The GLU molecules get therefore stretched and the less bound electron is hanging out of the molecule core on the CD surface. Should positively charged particles be present just outwards, the ensuing attraction could be able to break the binding of the electron with its parent molecule transforming it into a positive ion. There should exist therefore a critical value of pH below which the GLU molecule gets ionized in aqueous solution. Since at pH 7 GLU is a neutral molecule there is a range where GLU is a polar molecule: that’s the range where the Zhadin effect is detectable³⁸.

In such a range of pH values the GLU molecule is ionized, although its charge could be screened by the cloud of electrons surrounding the outer side of the surface of CD.

When pH becomes low enough to spoil this electron cloud GLU ions can appear in the open. However GLU ions respond to applied magnetic fields in the same way irrespective of the presence of the electron cloud. This allows us to understand why in the absence of magnetic fields the critical pH for the ionization of GLU solutes is 1.5 whereas the threshold in presence of the Zhadin combination of magnetic fields grows up to 3.

The above dynamics of trapping of ions by CDs requires of course that CDs be present for a long time, almost in the order of seconds like the spike of the Zhadin effect. We have shown in section “Water is a quantum liquid” that in bulk water CDs live a very short time, giving rise to a flickering structure of the liquid. Consequently the trapping of ions of CDs can give rise to detectable effects only near surfaces, where water becomes EZ water³. It has been recently shown that unexpectedly large solute-free zones appear also at water-metal interfaces³⁹. The depth of such zones depends on the specific metal, increases with the applied over-potential and demands some time (tens of minutes) to be formed and to reach the equilibrium value. It is apparent that the water volume affected by the Zhadin’s phenomenon is only the volume of the interfacial water present in the experimental layout. In this context the reproducibility of the Zhadin effect depends critically on the state of the involved surfaces, which are the electrode surfaces in the case of the Zhadin experiment in the electrolytic cells and the glass surfaces in the case of the experiment performed by Giuliani, Zhadin and co-workers⁴⁰.

An additional important factor to be considered implies the ion species involved in the experiment. According to equation (7) ions approaching a CD are affected by the ponderomotive forces, so that light ions could be repelled so much to prevent them to reach the CD boundary. Only ions whose mass exceed a critical threshold could come

in so close contact with the CD surface to give rise to the Zhadin dynamics. As a matter of fact, by applying to a living system the same combination of magnetic fields as that used by Zhadin, Liboff observed the selective entrance of ions within cells^{41, 42}. However the only ions involved in this phenomenon were those heavier than sodium⁴³. The presence of the ponderomotive force on the CD boundary seems to provide a rationale to the existence of the well known sodium-potassium pump, since, according to equation (7), the repulsive force acting on the potassium ions (whose mass is about 40 a.u.) is about one half of the force acting on sodium ions, whose mass is about 23 a.u. In this way a mixture of sodium and potassium ions gets split by the ponderomotive force in two layers where the potassium is closer to the CD surface within the cell membrane.

Let us now come back to the analysis of ions lying on the CD surfaces near the electrodes. We know that ions heavier than sodium are able to fall on the CDs boundary and co-resonate there with the CD frequency, provided that they have the suitable spectral line. We have already observed that this is just the case for GLU. Should a static magnetic field be present these ions would orbit around the CD without any friction, just because of the coherent conditions that prevents collisions. As shown in reference⁴⁴ ions form always a coherent system at all concentrations, since their Debye-Huckel oscillations meet always the coherence conditions. A major effect of the ion coherence is the elimination of the inter-ionic collisions; collisions are forbidden since the requirement that all ions oscillate with the same frequency implies that all the Debye-Huckel cages should be equal. The piercing of a cage by an ion scattering against its neighbour would just destroy coherence. Moreover the coherence of the ions with the water CD prevents also the collision ion-water molecule. All these reasons imply that the motion of ions on the CD surfaces is frictionless and governed only by the fields trapped in the CD. The absence of a diffusive regime for ions voids all the objections embodied in the so called "*kT paradox*"⁴⁵. Moreover the large electromagnetic fields trapped in the CD screen out any externally applied electric field, so that ions trapped in a CD cannot join the electrolytic current.

We describe now the onset of the electrolytic current in a cell filled with a dilute solution of GLU. In the initial situation ions are dissolved in the incoherent fraction of water that is filling the interstices among the flickering CDs in the bulk water. In the absence of an applied voltage ions cannot penetrate into the EZ existing near the electrodes. When a voltage is switched on ions are pushed within the EZ and get a chance to be trapped on the CD surfaces. This process of falling on CDs requires a short time, during which the amount of the current depends on the total concentrations of GLU ions, which are all carriers of the current. However in a very short time a fraction of the ions gets trapped on the CDs, decreasing therefore the total amount of the current, whose value settles on a level lower than the original one. This phenomenon seems to be a sort of passivation of the electrode⁴⁶, but the electrodes play the only role of producing a thick layer of EZ water. As described in reference⁴³, the formation of this layer demands some time, so that the outcome of the Zhadin effect in the experiment depends critically on the interval of time between the filling of the electrolytic cell and the switch of the electric field. The outcome could be also critically affected by the presence of impurities on the electrodes able to disrupt the formation of the EZ water. Similar considerations could be applied to the glass containing the aqueous solution of GLU, in the case of the experiment of Giuliani, *et al.*⁴⁰.

The role of the magnetic fields

Let us now apply to the GLU-water system a static magnetic field \mathbf{B} orthogonal to the direction of the electric field. Ions would acquire a rotational motion whose frequency is the cyclotron frequency:

$$\nu = \Omega/(2\pi) = 1/(2\pi)(q/m)B \quad (10)$$

Let us recall that ions are *not* independent particles moving in an environment at temperature T , but are the members of a coherent system that governs the behaviour of the components in a non thermal, i.e. electromagnetic, way. This fact makes possible to the ions to have a very short orbital radius under a quite weak magnetic field. On the CD surface the circular ion velocity v_0 is therefore:

$$v_0 = \Omega R_{CD} \quad (11)$$

where R_{CD} is the radius of CD.

Let us now analyze the action of a weak alternating magnetic field

$$\mathbf{B}_{ac} = B_{ac} \cos(\omega t) \quad (12)$$

– over-imposed on the above static field - on the GLU ions following the dynamics sketched in⁴.

On the CD surfaces, where electric and friction forces are absent, the equation of motion of the ions acted upon by the Zhadin combination of magnetic fields directed along the z axis is:

$$d\mathbf{v}/dt = \Omega(1 + \varepsilon \cos \omega t) \mathbf{v} \times \mathbf{z}/z \quad (13)$$

where \times denotes the vector product and

$$\varepsilon = B_{ac}/B \quad (14)$$

which gives the solutions

$$v_{\pm}(t) = \frac{1}{2}(v_x(t) \pm i v_y(t)) = v_0 \sum_n J_n(\varepsilon \Omega/\omega) \cos[(\Omega - n\omega)t + \phi] \quad (15)$$

where n ranges between $-\infty$ and $+\infty$, J_n denotes the n^{th} Bessel function and ϕ is a phase.

We recall that B_{ac} is extremely weak which means that J_1 only contributes to the r.h.s. of equation (15). Therefore we get

$$v_{\pm}(t) = \frac{1}{2} v_0 (\varepsilon \Omega/\omega) \cos[(\Omega - \Omega)t + \phi] \quad (16)$$

since $J_1(z) = z/2$ in the limit $z \rightarrow 0$.

Equation (16) shows clearly that a translational velocity v_d develops when the resonance condition

$$\Omega = \omega \quad (17)$$

occurs.

We have the two components of v_d :

$$v_{d,x} = \frac{1}{2}(q/m)R_{cd} B_{ac} \cos(\phi) \quad v_{d,y} = - \frac{1}{2}(q/m)R_{cd} B_{ac} \sin(\phi) \quad (18)$$

The appearance of a translational velocity is possible only when the sum in eq. (15) shrinks to one single term, whose time dependence can be dropped through a resonance condition. This means that such possibility exists only for very small values of B_{ac} and is lost when the contribution of other terms cannot be neglected. The phenomenon exists only within a window of small values of B_{ac} , in agreement with the experiments. The translational velocity induced by the application of a weak field B_{ac} extracts ions from the cyclotron orbits on the CD surfaces, sending them in the non coherent fraction of water where electric and friction forces are felt. This emptying of the orbits occurs during one period of revolution of the orbiting ions $T=1/\nu$.

The extraction of ions from the cyclotron orbits restores the number of the carriers of the current up to the original value, nullifying the effect of the supposed “passivation” of the electrodes reported in Comisso *et al.*⁴⁶. Since, as discussed above, this phenomenon occurs only in the interfacial water close to the electrode the discharge of the extracted ions is almost instantaneous accounting for the narrow width of the current peak. The refilling of the cyclotron orbits on the surfaces of CDs demands time and this fact explains why the appearance of new peaks cannot occur soon, after the detection of one of them.

The extraction of the ions from the cyclotron orbits induces, because of the conservation of angular momentum, the onset of a rotational motion within the ensemble of almost free electrons within the CD, namely a vortex of electrons with an associated magnetic dipole moment. The appearance of this vortex induces a change of the magnetic field B_{water} trapped in the volume of permanently coherent water, i.e. EZ water. Calling $t=0$ the time of application of B_{ac} we get :

$$B_{water}(t) = B_1 + B_2 \Theta(t) \quad (19)$$

where $\Theta(t)$ is the step-function

$$\Theta(t) = \begin{cases} 0 & \text{when } t < 0 \\ 1 & \text{when } t > 0 \end{cases} \quad (20)$$

whose time derivative is just the Dirac peak function $\delta(t)$.

According to the Maxwell equation

$$\text{rot}(\mathbf{E}) = - \partial \mathbf{B} / \partial t \quad (21)$$

a pulsed electric field should appear when a sudden change of the internal magnetic field of the solution occurs. It is just this field that helps us to push ions far from the cyclotron orbits on the surfaces of the CDs. It is also this field that produces the pulsed current in the induction coils detected in the experiment of Giuliani, *et al.*³⁶. This experiment therefore corroborates the theoretical scheme presented here.

Conclusions

The Zhadin effect reveals a non thermal dynamics going on in dilute aqueous solutions of amino acids. Living organisms are more complex systems but include basically the same ingredients. The presence of an electromagnetic governance of the phenomena occurring there cannot be excluded any longer, so that we cannot deny the existence of non thermal effects produced by externally applied fields when they match suitable frequency requirements.

In the band of extremely low frequencies evidence for the existence of such non thermal effects has been reported in many cases. In particular the application of the combination of DC-AC magnetic fields early suggested by Liboff and Zhadin has been observed to be present in aqueous solutions, also without sunk electrodes – as observed by Giuliani, Zhadin and co-workers – and to be able to stimulate human cell maturation and stem cell differentiation⁴⁴⁻⁵³.

Acknowledgment

We thank MN Zhadin for the use of his figures in the text.

References

1. Szent-Gyorgyi A. Bioenergetics. Academic Press, New York, 1957.
2. Henniker JC. The depths of surface zone of a liquid. Rev Mod Physics 1949; 21: 322-41.
3. Zheng JM, Chin WC, Khijniak E Jr, *et al.* Surfaces and interfacial water: evidence that hydrophilic surfaces have long range impact. Ad Colloid Interface Sci 2006; 23: 19-27.
4. Pollack GH. Cells, gels and engines of life. Ebner & Sons, USA; 2001.
5. Szent-Gyorgyi A. Bioenergetics. Science 1956; 124: 873-5.
6. Preparata G. QED Coherence in matter. World Scientific, Singapore, 1995.
7. Del Giudice E, Vitiello G. Role of the electromagnetic field in the formation of domains in the process of symmetry-breaking phase transition. Physical Rev A 2006; 74.
8. Novikov VV, Zhadin MN. Combined action of weak static and alternating low frequency magnetic fields on ionic currents in aqueous amino acid solutions. Biofizika 1994; 39: 45-9.
9. Zhadin MN, Novikov VV, Barnes FS, *et al.* Combined action of static and alternating magnetic fields on ion current in aqueous glutamic acid solution. Bioelectromagnetics 1998; 19 (1): 41-5.
10. Franks ed. Water, a comprehensive treatise. 7th Vol. New York, USA: Plenum Press, 1982.
11. Arani R, Bono I, Del Giudice E, *et al.* QED coherence and the thermodynamics of water. Int J Mod Physics 1995; 9: 1813-41
12. Sachs J. Physiologische Notizen II. Beitrage zur Zelltheorie. Flora 1892; 75: 57-67.
13. Huang C, Wikfeldt KT, Tokushima T, *et al.* The inhomogeneous structure of water at ambient conditions. Proc Natl Acad Sci USA 2009; 106: 15241-6.
14. Yinnon C, Yinnon T. Domains in aqueous solutions: theory and experimental evidence. MPLB 2009; 23(16): 1959-73.
15. Katsir Y, Miller L, Aharonov Y, *et al.* The effect of rf-irradiation on electrochemical deposition and its stabilization by nanoparticle doping. J Electrochemical Soc 2007; 154(4): 249-59.
16. Armstrong WG. Electrical phenomena. The Newcastle Literary and Philosophical Soc., The Electrical Engineer 1893; 10: 145-54.
17. Fuchs E C, Woisetschlager J, Gatterer K, *et al.* The floating water bridge. J Phys D: Appl Phys 2007; 40: 61112-4.
18. Fuchs EC, Bitschnau B, Woisetschlager J, *et al.* Neutron scattering of a floating heavy water bridge. J Phys D: Appl Phys 2009; 42(6): 65502-5.

19. Fuchs EC, Bitschnau B, Di Fonzo S, *et al.* Inelastic UV scattering in a Floating Water Bridge. 2009 submitted to J Phys D: Appl Phys.
20. Tedeschi A. Is the living dynamics able to change the properties of water? Int J Design & Nature and Ecodynamics 2010; 5(1): 60-7.
21. Marchettini N, Del Giudice E, Voikov VL, *et al.* Water: a medium where dissipative structures are produced by a coherent dynamic. submitted to J Theor Biol 2010; 265(4): 511-6.
22. Buzzacchi M, Del Giudice E, Preparata G. Coherence of the glassy state. Int J Mod Phys B 2002; 16(25): 3771-86.
23. Zhou EH, Trepatt X, Park CY, *et al.* Universal behavior of the osmotically compressed cell and its analogy to the colloidal glass transition. PNAS 2009; 106(26): 10632-7.
24. Pagnotta SE, Bruni F. The glassy state of water: a 'stop and go' device for biological processes, in water and the cell. Gerald H. Pollack, Ivan L. Cameron and Denys N. Wheatley eds., Springer Verlag, Heidelberg, 2007: 93-112.
25. Del Giudice E, Preparata G, Vitiello G. Water as a free electric dipole laser. Phys Rev Lett 1988; 61(9): 1085-8.
26. Celaschi S, Mascarenhas S. Thermal-stimulated pressure and current studies of bound water in lysozyme. Biophysical J 1977; 20(2): 273-7.
27. Cohen Tannoudj CN. Photons and atoms, J Wiley ed., New York, 1997.
28. Del Giudice E, Preparata G. A new QED picture of water in Macroscopic Quantum Coherence. Sassaroli E, Srivastava YN, Swain J, *et al.* eds. World Scientific, Singapore, 1998.
29. Del Giudice E, Pulselli R, Tiezzi E. Thermodynamics of irreversible processes and quantum field theory: An interplay for the understanding of ecosystem dynamics. Ecol Model 2009; 220 (16): 1874-9.
30. Nicolis G, Prigogine I. Self-organization in non-equilibrium systems. Wiley & Sons, New York, 1977.
31. Montagnier L, Aissa J, Ferris S, *et al.* Electromagnetic signals are produced by aqueous nanostructures derived from bacterial DNA sequences. Interdiscip Sci Comput Life Sci 2009; 1: 81-90.
32. Blank M, Goodman R. A mechanism for stimulation of biosynthesis by electromagnetic fields: charge transfer in DNA and base pair separation. J Cell Physiol 2007; 214(1): 20-6.
33. Blackman CF, Benane SG, House DE, *et al.* Effects of ELF (1-120 Hz) and modulated (50 Hz) RF field on the efflux of calcium ions from brain tissue in vitro. Bioelectromagnetics 1985; 6: 1-11.
34. Blackman CF, Benane SG, Rabinowitz JR, *et al.* A role for the magnetic field in the radiation-induced efflux of calcium ions from brain tissue in vitro. Bioelectromagnetics 1985; 6: 327-37.
35. Liboff AR. Geomagnetic cyclotron resonance in living cells. J Biol Phys 1985; 9: 99-102.
36. Giuliani L, Grimaldi S, Lisi A, *et al.* Action of combined magnetic fields on aqueous solution of glutamic acid: the further development of investigations. BioMagnetic Res Technol 2008; 6: 1.
37. U.S. Nat. Inst. of Standards and Technology (NIST): IR Spectrum of L-Glutamic Acid (see IR spectrum of DL-Glutamic Acid too). www.webbook.nist.gov
38. Zhadin MN, Giuliani L. Some problems in modern bioelectromagnetics. Electr Biol Med 2006; 25(4): 269-80.
39. Chai B, Schergen L, Pollack GH. Water-metal interfaces: unexpectedly large solute-free zones. Poster at the 4th Annual Conference on the Physics, Chemistry and Biology of Water, Vermont, 2009.
40. Giuliani L, D'Emilia E, Grimaldi S, *et al.* Investigating the ICR Effect in a Zhadin's Cell. Int J Biomed Sc 2009; 5(2): 181-6.
41. Liboff AR. The cyclotron resonance hypothesis: experimental evidence and theoretical constraints. In Ramel C and Norden B, eds. Interaction Mechanisms of Low-Level Electromagnetic Fields With Living Systems. Oxford University Press, London, 1991, 130-47.
42. Liboff AR, McLeod BR, Smith SD. Resonance transport in membranes. In Brighton CT and Pollack SR, eds. Electromagnetics in Medicine and Biology, San Francisco Press, Inc., San Francisco, 1991.
43. Liboff AR: Personal Communication.
44. Del Giudice E, Preparata G, Fleischmann M. QED coherence and electrolyte solutions, J. Electroanal Chem 2000; 482: 110-6.
45. Adair RK. Comment: analyses of models of ion actions under the combined action of AC and DC magnetic fields. Bioelectromagnetics 2006; 27(4): 332-4.
46. Comisso N, Del Giudice E, De Ninno A, *et al.* Dynamics of the ion cyclotron resonance effect on amino acids adsorbed at the interfaces. Bioelectromagnetics 2006; 27(1): 16-25.

47. Del Giudice E, Fleischmann M, Preparata G, *et al.* On the ‘unreasonable’ effects of E.L.F. magnetic fields upon a system of ions. *Bioelectromagnetics* 2002; 27: 522-30.
48. Lisi A, Ciotti MT, Ledda M, *et al.* Exposure to 50 Hz electromagnetic radiation promote early maturation and differentiation in newborn rat cerebellar granule neurons. *J Cellular Physiol* 2005; 204(2): 532-8.
49. Lisi A, Rieti S, Cricenti A, *et al.* ELF non ionizing radiation changes the distribution of the inner chemical functional groups in human epithelial cell (HaCaT) culture. *Electrom Biol Med* 2006; 25(4): 281-9.
50. Lisi A, Ledda M, Rosola E, *et al.* Extremely low frequency electromagnetic field exposure promotes differentiation of pituitary corticotrope-derived AtT20 D16V cells. *Bioelectromagnetics* 2006; 27(8): 641-51.
51. Lisi A, Ledda M, de Carlo F, *et al.* Calcium ion cyclotron resonance (ICR) transfers information to living systems; effects on human epithelial cell differentiation. *Electrom Biol Med* 2008; 27(3): 230-40.
52. Lisi A, Ledda M, de Carlo F, *et al.* Ion cyclotron resonance as a tool in regeneration medicine. *Electromagn Biol Med* 2008; 27(2): 127-33.
53. Gaetani R, Ledda M, Barile L, *et al.* Differentiation of human adult cardiac stem cells exposed to extremely low-frequency electromagnetic fields. *Cardiov Res* 2009; 85(3): 411-20.

Water structures and effects of electric and magnetic fields

Seyitriza Tigrek, Frank Barnes
University of Colorado at Boulder, Colorado, USA

Abstract

This chapter reviews the characteristics of water that lead to many of its properties in electric and magnetic fields. This includes some of the structures that water molecules can form, the dielectric constant and conductivity as a function of frequency, the mobility, the magnetic susceptibility and a few of structures that form water complexes around ions that lead to their electrical characteristics. It also briefly reviews some of the effects of water on proteins.

***Key words:* water, electric and magnetic fields, ions, hydrogen, oxygen, proteins**

Introduction

Although water has been studied for a very long time, it is still not completely understood. Reviewing some of the unique characteristics of water and its structure in the presence of ions is a starting point for understanding how bound water molecules modify the behavior of ions and other biological molecules. The unique behavior of water is largely due to dynamic hydrogen bonded networks that exist when water is in liquid form. Hydrogen bonds form a random and percolated network. Many experiments and simulations have been carried out which give detailed information about these structures and there are a significant number of books and reviews of many of the unique properties of water^{1,2} and many others.

In this chapter, the structure of water will be reviewed with emphasis on the effects of the water structures on electrical and magnetic properties, including water's interaction with its environment of ions and molecules as a function of temperature. Our exposures to electric and magnetic fields, EM, in everyday life are increasing, especially as a result of increased cell phone usage. Many people are concerned about the possibility that the radiation from mobile phones can cause adverse health effects³. Additionally, important therapeutic applications of electric fields to bone repair and wound healing are beginning to be studied. Since our body contains very large amounts of water, it is expected that EM interaction with water will be at least part of the process leading to biological effects.

Address: Frank Barnes, Electrical Computer and Energy Engineering Department, University of Colorado at Boulder, Boulder Colorado, 80309 USA - e-mail: Frank.Barnes@colorado.edu

An objective of this chapter will be to bring together some of the material on the structure of water and its interactions with molecules and ions in the presence of electric and magnetic fields so as to provide a basis for extending our understanding of the effects of externally applied fields to biological systems. In particular, we hope to provide some background on how the characteristics of water affect its dielectric constant and the conductivity of ions in solutions.

Background

The details of the mechanism by which weak electric and magnetic fields can affect biological systems are not yet completely understood. Some of the most obvious mechanisms by which these fields interact with biological systems have been reviewed in the references⁴. The effects of electric fields include the generation of ion currents, rotational torques on electric dipoles, shifts in energy levels (Stark Effect), and transitions between energy levels and induced voltages across membranes. DC magnetic fields can apply torques to magnetic dipoles, and shift energy levels (Zeeman Effect). Time varying magnetic fields can induce electric fields and cause transitions between energy levels. Experimental results from weak fields showing changes in biological system have led to a variety of theories including the cyclotron resonance and ion paramagnetic resonances⁵. Additional work has been done on the theory that uses quantum electrodynamics predict relatively large stable coherent domains that may have long life times⁶. A discussion of this approach will be covered in other parts of this publication. The narrow frequency and amplitude ranges over which some of these experiments work has led us to look for mechanisms that can isolate the ion responses from its surroundings and the thermal bath. These theories have had mixed success in the prediction of the effects of weak magnetic fields on biological systems and acceptance by the scientific community at large. There is often a lack of data that connects the mechanism by which these fields cause changes in ion responses to the experimental observations in biological systems.

The experiments by Zhadin showing a spike in the current flowing between two electrodes in simple solutions of amino acids in water at a specific frequency of the applied electric field and values of the applied DC magnetic field avoid many of the complexities associated with the application of these fields to biological systems. These results have been particularly puzzling^{7,8} and the results have been reproduced by N. Comisso and Giuliani and their colleagues^{9,10}. These experiments and the other results showing sharp resonances at low frequencies that are functions of the magnetic field have encouraged us to look for ways in which ions could be isolated from the surrounding thermal bath and to hypothesize that bound water might form structures around ions that could isolate them from the liquid water around them. As a starting point for examining this possibility, we have written this review of water structures that we hope will be of interest to others who are interested in understanding the effects of weak electric and magnetic fields on biological systems.

A Review of Some Basic Molecular Physics

Molecules are arrays of atomic nuclei with well defined distances and positions between them that confine electrons to regions of space known as orbitals. An atomic

orbital may be occupied by two electrons and confined to encircle one nucleus. Molecular orbitals may be confined to one nucleus or confined to a path encircling more than one nucleus. Those electrons encircling more than one nucleus in a molecule define the chemical reactivity of a molecule and can be in three positions: core electrons, π electrons, and σ electrons^{11,12}.

Core electrons are immediately adjacent to a nucleus and provide the greatest electron density. They are chemically inert. Valance electrons are the outermost electrons surrounding each atom. They form the basis of the chemistry of a molecule, its bonds and reactivity. Valance electrons according to Lewis structure can be bonding electrons or lone pairs of electrons, which also assign formal charge to atoms. Bonding molecular orbitals are made of overlapping two or more atomic orbitals and can be distinguished as π or σ orbitals depending on the nature of the bonds^{11,12}.

The s orbitals have energy levels with angular moment values of $l = 0$. The atomic p orbitals have angular moment with a quantum number $l = 1$ and form π molecular orbitals with linear combinations. The p orbitals for two adjacent atoms have paths only above and below the line centers connecting the atoms, and this prevents rotation about the axis and makes them rigid. A π orbital can be bonding, nonbonding, or anti-bonding depending on it is energy level being less than, equal to, or greater than the energy level of an isolated p orbital. Hybrids of an s atomic orbital and a p atomic orbital overlap to form a σ bond; they are stronger covalent bonds than π bonds. σ bonds form the molecular skeleton of a molecule defining the structure, with particular bond angles. When an atom contributes a p orbital to a π system it will be hybridized. [p , sp^2 , sp^2 , sp^2], and the bonds will be planar and radiate in three directions from the atom at approximately 120° angles. When not contributed to by a p orbital, the bonds will be hybridized [sp^3 , sp^3 , sp^3 , sp^3]. σ structure bonds will radiate in four directions tetrahedrally, at angles of approximately 109.5° . The approximate characteristics of these bonds can be calculated by building up from solutions of Schrodinger equation for dipole molecules using Walsh diagrams^{11,12}.

The Water Molecule

A representation of a single water molecule is shown in fig. 1 with two hydrogen atoms covalently bonded to an oxygen atom. For an isolated molecule in a vacuum, the hydrogen protons are bonded at an angle of 104.5° and the hydrogen oxygen bond length is 0.096 nm. The distance between the two hydrogen atoms, the intramolecular proton separation, is 0.152 nm. These distances depend on the method of measurement¹³.

The orbitals for the covalent hydrogen oxygen bonds are described as hybridized sp^3 orbitals and the two additional electron pairs are in σ orbits. The four substituents are oriented tetrahedrally around the oxygen¹¹.

The ground state of oxygen atom configuration is described as having electrons in $1s$ $2s$ $2p$ states. Electrons fill the orbits from lower to upper. An oxygen atom has 8 electrons. It starts with the $1s$ state which is filled by two electrons. Similarly the $2s$ state is filled. The $2p$ state has three axes, therefore, after electrons are equally distributed to three axes it will fill the second space. Since the total number of electrons is 8, this is the final configuration. This atomic basis leads to a bond angle of 90° between the O-H bonds (fig. 2a). The possibility of hybridizing the orbitals that would lead to a better bond can be considered as an alternative description. If tetrahedral hybrid orbitals are formed, the bond system can be represented as in fig. 2b. This would promote a pair of

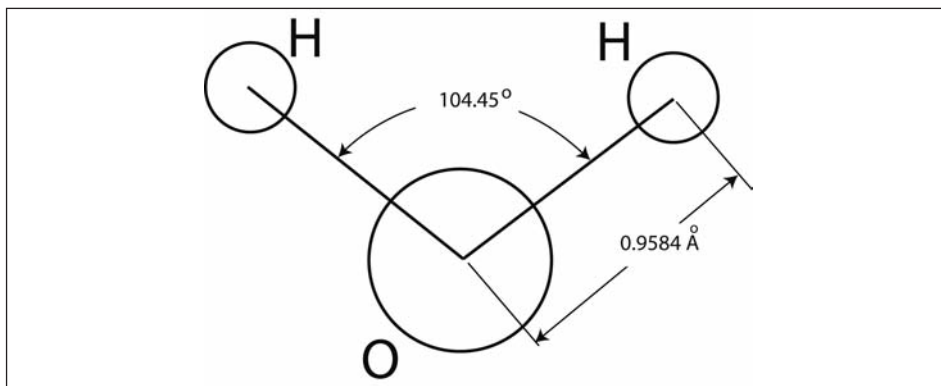

Fig. 1. Representation of a single water molecule

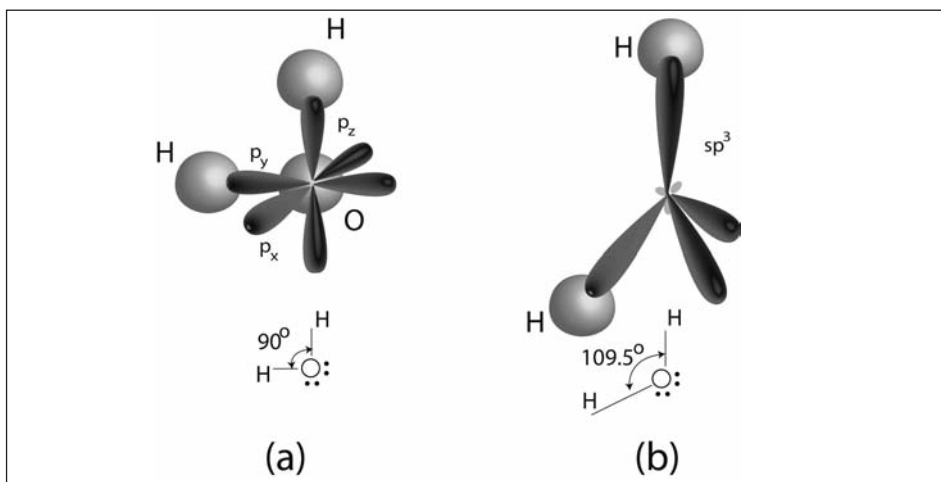

Fig. 2. Two descriptions of bonding in H₂O. The observed angle between the two O—H bonds is 105° (a) H₂O based on s, p_x, p_y and p_z orbitals oxygen (b) H₂O based on sp³ hybrid orbitals of oxygen¹⁴

electrons from low-lying 2s orbits to the higher energy sp³ hybrid orbitals. Since experiments find the bond angle in water is 105°, it is suggested that some intermediate description will be preferable¹⁴.

Since oxygen has higher electro negativity than hydrogen, water is a polar molecule. The oxygen has a slight negative charge while the hydrogen has a slight positive charge, giving the molecule a strong effective dipole moment. The interactions between the different dipoles of each molecule cause a net attractive force that is associated with water's high surface tension.

Water structures

Water structures can vary from a single molecule to clusters of hundreds of molecules bonded together (fig. 3). The simplest structures, after single molecules, are water

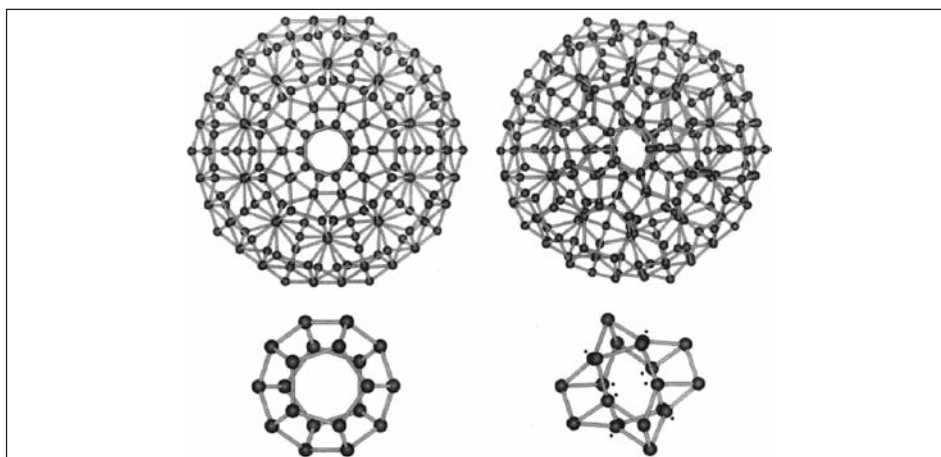

Fig. 3. An expanded icosahedral water cluster consisting of 280 water molecules with a central dodecahedron (left) and the same structure collapsed into a puckered central dodecahedron (right)^{16,17}

dimers. Fig. 4a shows the equilibrium structure of the water dimer¹⁵. The O-O distance is 0.2952 nm and hydrogen bond strength (dissociation energy) of $(\text{H}_2\text{O})_2$ is 3.09 Kcal/mol which corresponds to the zero-point corrected binding energy of 4.85 Kcal/mol (0.0485 eV)^{16,17}.

In this structure one hydrogen atom lies between the two oxygen atoms; this hydrogen is covalently bonded to one oxygen and is referred to as the proton donor. The other

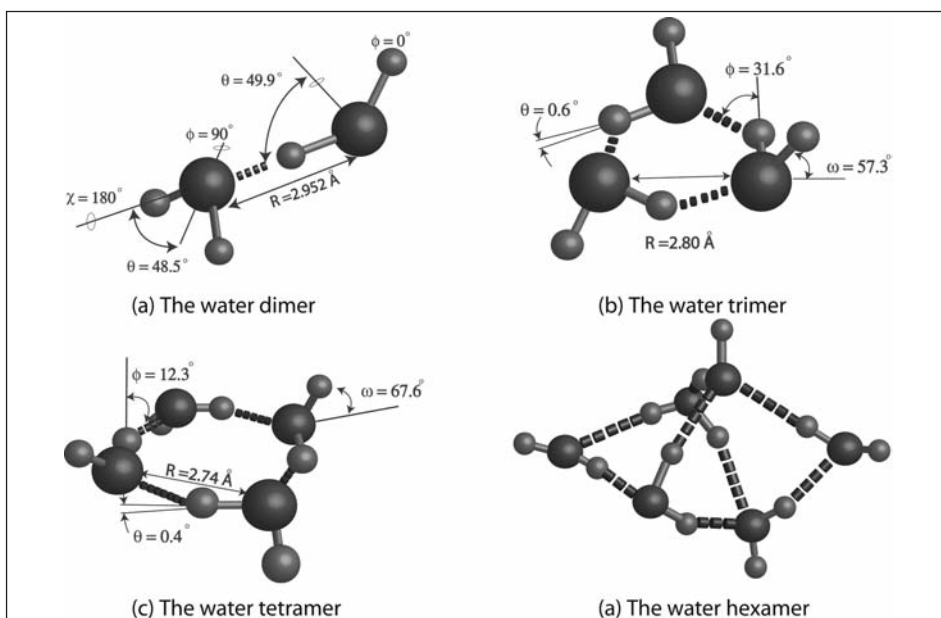

Fig. 4. Some of the many water molecule clusters¹⁵

oxygen is covalently bonded to two hydrogen atoms and is referred to a proton acceptor. The O-O distance is 0.298 nm. In this structure one of the four hydrogen lies on the lines of center between the two oxygen atoms as a proton donor which is covalently bonded to one of them. The proton acceptor oxygen atom is connected to two others covalently. The plane of two hydrogen atoms and the proton acceptor oxygen is 60° from the line of centers of two oxygen atoms. This means that two hydrogen atoms, a shared hydrogen and long pair of electrons are tetrahedrally arrayed in the dimer. The interaction between the hydrogen-oxygen σ bond on the donor molecule of water and the σ lone pair of electrons on the acceptor is an example of a hydrogen bond¹¹. The ability of water to act as both a proton donor and acceptor and the hydrogen bonds lead to its ability to form many complex structures.

The water trimer is a more rigid structure than the dimer bound by three H-bonds (fig. 4b). In the H-bonding structure of water tetramer each monomer acts as a single donor and acceptor and has one free and one bound H.

Studies suggest that the water trimer, tetramer, and pentamer structures have cyclic minimum energy formations. Larger water clusters have three dimensional geometries. There are many hexamer structures, the first five of which are indicated in fig. 5 with the results of the calculations using energy minimizations¹⁸. Some of the dominant structures in room-temperature liquid water are trimer, tetramer, pentamer, and hexamer. Narten *et al.* reported O-O bond distance of liquid water at 298 K for the cage hexamer as 0.285 nm, which was also confirmed by the calculations of Liu *et al.* O-O bond distance is 0.276 nm for the cyclic isomer of the hexamer¹⁸⁻²⁰.

The cage hexamer, which has the most stable form of $(\text{H}_2\text{O})_6$, contains eight hydrogen bonds holding it together (fig. 5)^{18,21}. Furthermore, four cage structures may be linked by successive flips of two free hydrogen atoms. The cage form and intermolecular zero-point energies of the hydrogen bonds are the cause of minimum-energy structure of water hexamer.

Liquid water retains much of the tetrahedral diamond lattice structure of ice, where the oxygen atoms are held together by hydrogen bonds to each of their four nearest

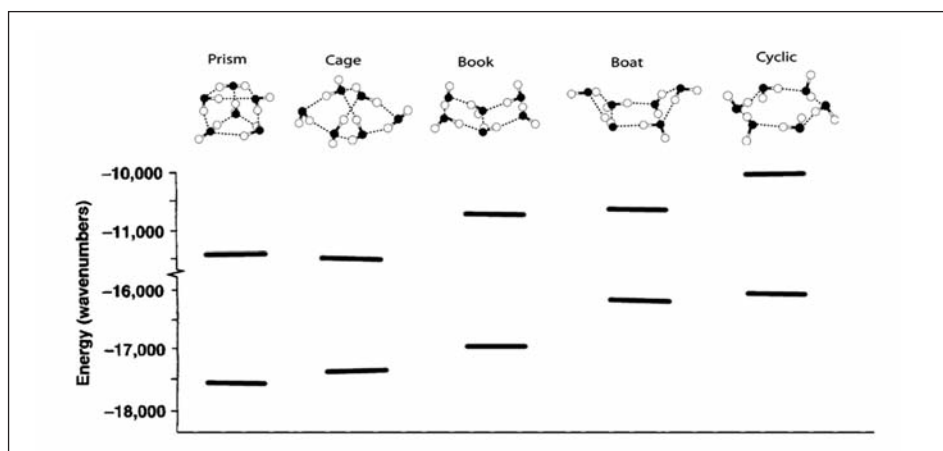

Fig. 5. Theoretical predictions of the stabilities of the five lowest-energy water hexamer structures. Values of D_e (lower line – lowest equilibrium dissociation energy) and D_0 (upper line – quantum vibrational zero-point energy) are shown. The zero-point energy is equal to $D_0 - D_e$ ¹⁸

neighbors. These structures are constantly breaking and reforming. The flexibility of the liquid water structure as compared to ice results from the increased liberation (from hindered rotation) of the rigid H₂O molecules within the lattice long enough to allow them to reform in different orientations while essentially maintaining an H bonded structure. The rotation is with respect to neighboring H₂O molecules. Orientation correlations are strong over short distances but decrease rapidly with distance. These rotations behave more like vibrational modes and do not show up in broadening other vibrational modes as they do in water vapor². The high heat capacity of water indicates that a large fraction of the water molecules are held in these structures near 0°C and that this fraction decreases as the temperature increases. Molecules in water near the melting point have around 10¹¹ or 10¹² movements per second which can be reorientational or translational. The speed of these movements decreases to 10⁵ or 10⁶ per second near 0°C in ice. Raising the water temperature increases this collision rate and at the macro level it results in decreasing viscosity, decreasing relaxation times, and greater rate of self-diffusion.

Hydrogen bonds between molecules in both ice and water cause the abnormal high mobility of H⁺ and OH⁻ and also the very large dielectric constant. The details of this motion are not well agreed upon in the literature; however, it appears that protons can move through water structures both by tunneling through relatively low potential barriers and with energy assisted movement through an excited state. These protons can move from one water molecule to the next in about 10⁻¹² seconds. Additional OH⁻ and H⁺ ions can diffuse through the liquid with a cloud of bound water molecules with mobility similar to that expected for other ions. One of the protons of an H₃O⁺ ion can jump along a hydrogen bond to combine with the adjacent water molecule, or one proton of water molecule can jump along a hydrogen bond to combine with the OH⁻. This leads to the motion of electric charge and current flow in the presence of a field²². In liquid water, hydrogen bonds are constantly forming and breaking so that the average path lengths of the structures are shorter than in ice and the number of single molecules increases as the temperature increases. This makes the mobility of H⁺ smaller in liquid water than in ice. The rapid proton transfer that is possible in hydrated complex is limited by the rate of formation and breaking of hydrogen bonds^{22, 23}. Another way of thinking about this process leads to a continuum model where the water network is distorted²⁴.

Water and Ions

Many of the effects of electric fields on biological systems are the result of the transport of ions from one location to another. These ions are often created as result the dissociation of an acid or a base. An acid is defined as a proton donor or alternatively as an electron acceptor so that

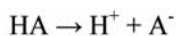

Where A is an atom such as Fluorine. A base is a proton acceptor so that

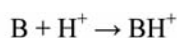

Where B is a molecule such as NH₃. The water molecule is unusual in that it is

amphoteric: it can be both an acid and a base. In the case of water there is an acid base equilibrium such that



At room temperature the equilibrium constant is such that the ion concentrations are about $10^{-7} \text{ mol L}^{-1}$. Roughly two out of every 10^9 water molecules at 25°C are ionized. This results in proton jumps between molecules and a mean lifetime of a protonated water molecule of $\sim 10^{-12} \text{ s}$ and a mean interval between successive associations of $\sim 5 \times 10^{-4} \text{ s}^{12}$.

Hydrogen bonds are non-covalent forces that arise between an acid and a base and may be an intermediary in acid base reactions. Hydrogen bonds provide no net free energy in protein folding but are responsible for aligning atoms and holding them at precise distances and constrain the angle between them. Of particular interest to us are hydrogen bonds to atoms like oxygen, nitrogen, carbon, and sulfur. These bonds are formed when the potential energy wells for a proton in a donor atom overlaps that of an acceptor atom so that the barrier between them is low enough to allow the transfer of protons. The forces of attraction are largely electrostatic in nature and vary with distance as the interaction between dipoles is shielded by the dielectric constant of the medium¹¹. Typical bond strengths are in the range of 10 to 40 KJ/mole or 0.10 to 0.40 eV, and this is approximately 4 to 15 times kT at 37.5°C where k is Boltzmann's constant.

Ions in water are not just simple charged particles as one would expect to observe in a vacuum, as the charges attract molecules of water that may be bound to them in a variety of configurations and with bonds of varying strength. Burnham *et al.*, explored equilibrium properties of the ion-clusters $\text{H}^+(\text{H}_2\text{O})_{100}$, $\text{Na}^+(\text{H}_2\text{O})_{100}$, $\text{Na}^+(\text{H}_2\text{O})_{20}$, and $\text{Cl}^-(\text{H}_2\text{O})_{17}$ in the temperature region 100-450 K. It was found that sodium and chloride ions largely reside on the surface of water clusters below the melting temperature. At the same time the solvated proton resides on or near the surface in both liquid and solid states²⁵.

The global minimum for the $\text{Na}^+(\text{H}_2\text{O})_{20}$ structure is seen in fig. 6. Hartke *et al.*²⁶ searched for global minima of $\text{Na}^+(\text{H}_2\text{O})_n$ in the range of $n=4-20$. Up to $n=17$ global minima were found to have sodium cation near the center. For n greater than $n=18$ the Na^+ moved to an off-center site with respect to the water cluster and is located in the solvation shell. Up to $n=25$ Na^+ continue to be off-center.

Burnham *et al.* presents the temperature-dependent radial distributions for $\text{Na}^+(\text{H}_2\text{O})_{20}$ where the Na^+ cation remains off-center up to 250 K. After that, the cluster melts and the

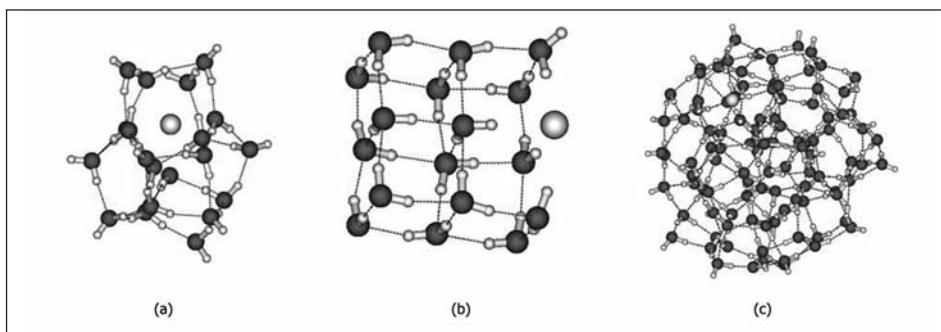

Fig. 6. Structures for the putative global minimum: (a) $\text{Na}^+(\text{H}_2\text{O})_{20}$, (b) $\text{Cl}^-(\text{H}_2\text{O})_{17}$, and (c) $\text{Na}^+(\text{H}_2\text{O})_{100}$ ²⁵

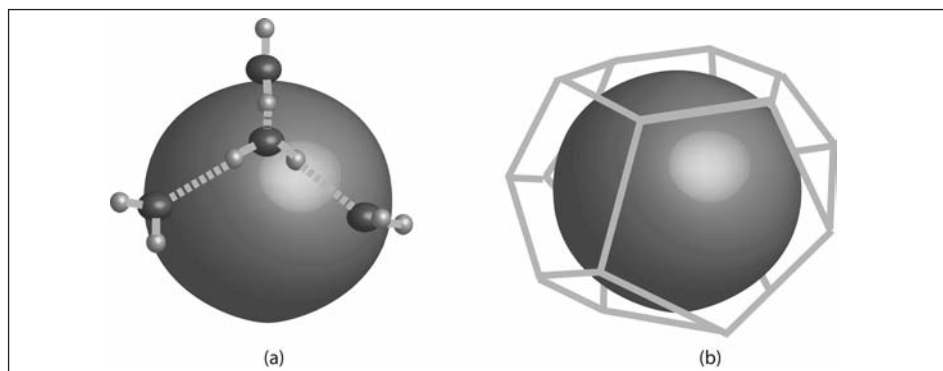

Fig. 7. Water molecules next to a nonpolar solute¹⁶

Na^+ distribution spreads around the center (fig. 6a)²⁵. The global minimum for $\text{Cl}^-(\text{H}_2\text{O})_{17}$ is shown in fig. 6b. In this structure, the chloride ion at low temperatures adopts one of the surface lattice sites. By passing the melting point it is solvated into the interior of the cluster. Fig. 6c shows $\text{Na}^+(\text{H}_2\text{O})_{100}$ cluster. It is reported that in low energy structures Na^+ cation adapts near surface site on roughly spherical water cluster below 250 K. Burnham studies also concluded that Na^+ , Cl^- , H^+ ions were generally excluded from the cluster interior at below the water-cluster freezing temperature and tend to reside within a few monolayers of the surface. However, above the melting point sodium and chloride are excluded from the surface of the cluster in the liquid region. Carignano *et al.*, investigated the effect of the ionic polarizability on the solvation of positive and negative ions in water, and he concludes that increases of the polarizability lead to a larger electrical field at the ion. This occurs through shrinking of the solvation shell around the ion and the asymmetric location of the ion in the cage. Positive ions have smaller polarizabilities than negative ions. However, for a given polarizability, the electrical field at an ion and probability of asymmetric location is larger for cations than for anions²⁷. Recent results using both ultra short laser pulses, (5×10^{-15} s) and calculations are giving insight into the motion of the water molecules around ions²⁸⁻³⁰.

Another interesting characteristic of water is its configuration in the hydration shell of nonpolar solutes and nonpolar side groups attached to biopolymers. Placing a solute molecule in liquid water causes rearrangement of random H-bond network. Water strengthens its network around the nonpolar solute while giving space for it. This can be done by placing its tetrahedral bonding directions in a straddling mode as shown in fig. 7a. The water molecule is tangential to the surface of the space with three tetrahedral directions. Maximum number of H-bonds is preserved this way (fig. 7b)¹⁶.

Electrical Mobility and Conductivity

Electrical conductivity in electrolyte solutions depends on the natures of the dissolved substance and the solvent, the concentration, temperature, pressure, viscosity, and dielectric constant of the solvent³¹. The electrical characteristics of a solution can be described by either a complex dielectric constant or a complex conductivity depending on the application. If we apply an electric field to a solution containing ions at low fre-

quencies to first order the real part of the current density, \vec{J}_i , for a given molecule or ion is given by

$$\vec{J}_i = N_i \mu \vec{F} \tag{1}$$

where N_i is the ion concentration, and μ is the mobility in seconds per kilogram, \vec{F} is the force in newtons⁴. It is usual to think of the current density in terms of the conductivity, $\sigma = \sum q_i N_i \mu_i$, and N_i is the concentration of each ion, μ_i is the mobility. However, in highly inhomogeneous biological materials the gradients of the electric field may be large and the force on a charged particle or molecule may have two components so that

$$\vec{F} = q \vec{E} + (\vec{P} \cdot \vec{\nabla} \vec{E}) \tag{2}$$

where is \vec{P} the sum of the permanent and induced dipole moments.

The drift portion of the ion currents takes the form

$$\vec{J} = \sum q_i N_i \mu_i \vec{E} + \sum N_i \mu_i \vec{P}_i \cdot \vec{\nabla} \vec{E} \tag{3}$$

and \vec{P} is the dipole moment. See Table 1 for some typical values of mobility.

The forces applied by an electric field superimpose a drift velocity on top of the much larger random thermal velocity in opposite directions for positively and negatively charged particles. These forces can lead to a redistribution of ions or molecules as a result of the differential mobilities and to an increase in the concentration of ions at interfaces. The average drift velocity for a charged particle is given by

$$\vec{v} = \mu_i \vec{E} \tag{4}$$

The separation of molecules as a result of the different velocities in a DC electric field is known as electrophoresis and is frequently used to identify large molecules or charged colloidal particles. The separation of particles in an AC field gradient is known as dielectrophoresis³².

Table 1 - Ionic mobilities in water¹² (at 298 K, u/10⁸ m² s⁻¹V⁻¹)

Cations		Anions	
Ag ⁺	6.42	Br ⁻	8.09
Ca ²⁺	6.17	CH ₃ CO ₂ ⁻	4.24
Cu ²⁺	5.56	Cl ⁻	7.91
H ⁺	36.23	CO ₃ ²⁻	7.46
K ⁺	7.62	F ⁻	5.70
Li ⁺	4.01	[Fe(CN) ₆] ³⁻	10.5
Na ⁺	5.19	[Fe(CN) ₆] ⁴⁻	11.4
NH ₄ ⁺	7.63	I ⁻	7.96
[N(CH ₃) ₄] ⁺	4.65	NO ₃ ⁻	7.40
Rb ⁺	7.92	OH ⁻	20.64
Zn ²⁺	5.47	SO ₄ ²⁻	8.29

For a spherical particle in a homogeneous insulating fluid the mobility μ_i is given by

$$\mu_i = \frac{q}{6\pi\eta a} \quad 5$$

provided that the particle is significantly larger than the background particles of the fluid where η is the viscosity of the fluid and a is the radius of the particle. Bound water molecule change the effective radius of the particle and then partially shield its charge as has been shown in the previous section. Additionally, small counter-ions may flow in the direction opposite to the particle motion, exerting a viscous drag. The theory for motion of a rigid sphere through a conducting liquid is complicated if all these effects are taken into account. Furthermore, the size and shape of the bound water molecules around the molecule may fluctuate in time. Often some of the parameters, including the charge on the sphere, are not measurable. However, a relatively simple approximate expression for the electrophoretic mobility is often used

$$\mu_i = \frac{\epsilon_i \zeta}{4\pi\eta} \quad 6$$

where ϵ_i and η are the dielectric permittivity and the viscosity of the fluid in Kg/m-sec and ζ is the electrical potential drop from the particle surface across the bound fluid, to the interface where the liquid begins to flow under the shear stress. Stated another way the “zeta potential,” ζ , is the potential at the surface boundary between the stationary fluid and the liquid that is moving with the particle. It is to be noted that ζ is less than the total potential ψ' across the charge double layer surrounding the charged particle. The water molecules bound to the ions increase the effective diameter and reduce the effective charge. This, in turn, makes the mobility less than that which might be expected at first from the atomic size and Stokes' Law.

Pure water is a good insulator, however it is almost impossible to have water without ions of other materials. Solutes dissolve in water and separate into ions that conduct electricity. Table salt (NaCl) is a very good example. The theoretical maximum electrical resistivity for water is approximately $182 \text{ k}\Omega \cdot \text{m}^2/\text{m}$ (or $18.2 \text{ M}\Omega \cdot \text{cm}^2/\text{cm}$) at 25°C , which agrees with the experimental results. One limit of the resistivity is the self-ionization of H_2O into the hydronium cation H_3O^+ and the hydroxide anion OH^- . Electrical conductivity of pure water is approximately $0.055 \text{ }\mu\text{S}/\text{cm}$ at 25°C but will increase significantly with small amounts of ionic material such as hydrogen chloride. Solutions that contain ions conduct an electric current and are called electrolyte solutions. Some good electrical conductors are acids, bases, and salts. Under an applied potential gradient, movement of ions towards the anode and cathode will be slow compared to the thermal velocity as is given in Equation 4 above. The limiting conductivity of some solutions is given in Table 2.

The conductivity of biological fluids such as blood which contains cells is in the vicinity of $\sigma = 0.6 \text{ Sm}^{-1}$, while for physiological saline it is approximately 1.4 Sm^{-1} .

Table 2 - Limiting ionic conductivities in water at 298 K, λ /(S cm² mol⁻¹) where λ is molar conductivity¹²

Cations		Anions	
Ba ²⁺	127.2	Br ⁻	78.1
Ca ²⁺	119.0	CH ₃ CO ₂ ⁻	40.9
Cs ⁺	77.2	Cl ⁻	76.35
Cu ²⁺	107.2	ClO ₄ ⁻	67.3
H ⁺	349.6	CO ₃ ²⁻	138.6
K ⁺	73.50	(CO ₂) ₂ ⁻	148.2
Li ⁺	38.7	F ⁻	55.4
Mg ²⁺	106.0	[Fe(CN) ₆] ³⁻	302.7
Na ⁺	50.10	[Fe(CN) ₆] ⁴⁻	442.0
[N(C ₂ H ₅) ₄] ⁺	32.6	I ⁻	76.8
[N(CH ₃) ₄] ⁺	44.9	NO ₃ ⁻	71.46
NH ₄ ⁺	73.5	OH ⁻	199.1
Rb ⁺	77.8	SO ₄ ²⁻	160.0
Sr ²⁺	118.9		
Zn ²⁺	105.6		

Data: KL, RS

The permittivity of pure water

The permittivity or dielectric constant of a given material can be approached in two ways. First, it can be thought of as the relation between the electric field \vec{E} and the displacement \vec{D} of electric charge or the electrical polarization in a material so that

$$\begin{aligned} \vec{D} &= \epsilon_0 \vec{E} + \vec{P}' \\ &= \epsilon_0 \epsilon \vec{E} \end{aligned}$$

where ϵ_0 is the dielectric constant of free space and \vec{P}' is the dipole moment per unit volume and

ϵ is the relative dielectric constant. The \vec{P}' for small fields can also be expressed as

$$\vec{P}' = N_i \alpha_i \vec{E}$$

where α_i is the total dipole moment of the particle.

For materials with loss, the relative dielectric constant is complex and is given by

$$\begin{aligned} \hat{\epsilon}(\omega) &= \epsilon'(\omega) + i\epsilon''(\omega) \\ &= \epsilon' + j\sigma / \omega \epsilon_0 \end{aligned}$$

ϵ'' is the measurement of the amplitude and the time dependent fluctuations of total dipole moment coming from individual permanent molecular dipoles and molecular polarizabilities. The real part of the static permittivity ϵ'' is related to the stored energy within the medium, and ϵ' is connected to the dissipation of electromagnetic energy³³, ω is the angular frequency.

It is to be noted that the same experimental data can be described by a complex conductivity

$$\sigma = \sigma' + i\sigma''$$

Water is considered to be pure degassed water with a conductivity of less than 10^{-6} S/m at atmospheric pressure³⁴. Fig. 8 shows temperature variation of ϵ' and ϵ'' for five fixed frequencies in the microwave range. Fig. 9 shows ϵ' and ϵ'' variation for frequencies from static to far infrared.

There is a large number of theories that have been used to explain the measure values of ϵ and the extent to which the various water structures are required to explain them. These include breaking of the bonds and changing the angles between the hydrogen and oxygen atoms. One way of thinking about the dielectric constant is to think of it as the fraction of the electric field that is shorted out by the movement of charged particles that are limited in the extent of their motion. In the case of the water structures described earlier, the dielectric constant can be thought of as resulting from the movement of hydrogen ions from one end to the other or the induction of a dipole moment across the struc-

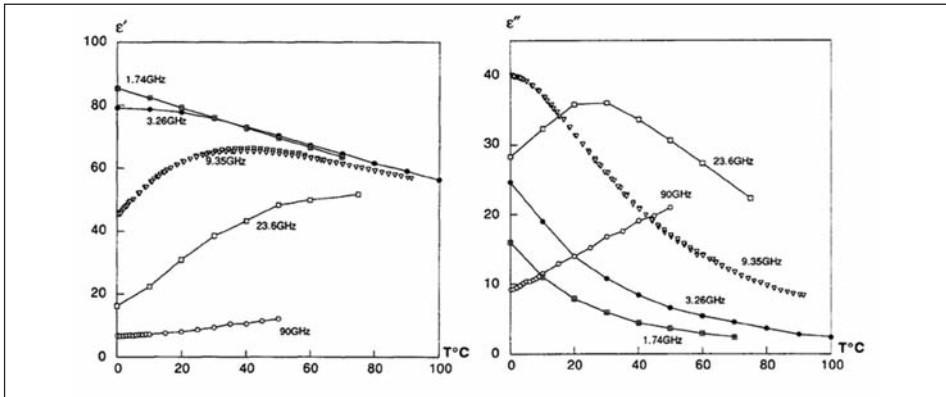

Fig. 8. Experimental data for water : ϵ' ϵ'' as a function of temperature at five frequencies³⁴

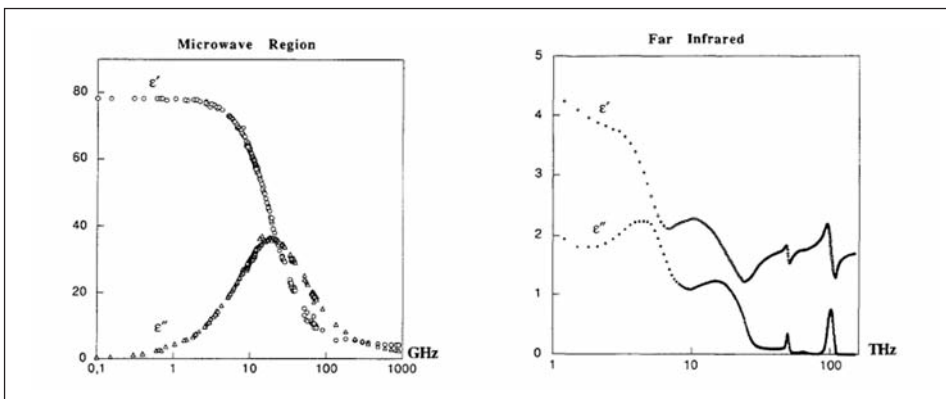

Fig. 9. Experimental data for water: Water permittivity at 25°C, frequency from static to the far infrared³⁴

ture. This structure with an induced dipole moment may also rotate to align along the field. The average size of these structures can be expected to decrease as the temperature increases as the thermal energy available to break hydrogen bonds increases. The fraction of the dielectric constant contributed by the ability of these structures to short out the electric field would be expected to decrease as the temperature increases. The different sized structures can be expected to have different time constants for both the motion of the hydrogen ions and the rotation of the structure. The relative dielectric constant for water clusters for sizes ranging from 2 to 20 have been calculated by a variety of methods. The low frequency values for ϵ_k fluctuate from $\epsilon_k = 83$ to 83.8 at 298 K as the size of the clusters change³⁵ and approach the bulk value of 82.95 as the cluster size gets larger than 12.

The measured dielectric data can be fitted to a Cole–Cole model

$$\epsilon = \epsilon_{\infty} + \frac{\epsilon_s - \epsilon_{\infty}}{1 + (j\omega\tau)^{(1-\alpha)}} + \frac{\sigma_i}{j\omega\epsilon_0} \quad 7$$

where ϵ_s and ϵ_{∞} are the limit of the permittivity at low and high frequencies, τ is the relaxation time, σ_i is the ionic conductivity, ϵ_0 is the permittivity of free space, and α is a distribution parameter. For $\sigma_i = 0$, and for a single relaxation time process $\alpha = 0$ this becomes the well-known Debye equation³⁶. The values of these parameters vary a little with different authors and which of the constants they adjust to best fit their data. At low frequencies the static value of the dielectric constant as function of temperature can be approximately described by a single relaxation time $\tau = 8$ ps and 18KJ/mol at 25°C and the Debye theory¹ gives $\tau = 4\pi a^3 \eta / kT$. They assume a spherical cluster with single hydrogen bond strength.

Additional information can be gained from the infrared measurements that are characteristic of the excitation of various molecular bonds, and these measurements give more information on the effects of various water structures on its electrical properties. Fig. 10 shows permittivity as a function of frequency and temperature. Measurement in the far infrared in the range from 1 GHz to 7 THz show dielectric and absorption characteristics I,II,III, that correspond to relaxation times at a temperature of 25°C of 8.31, 1.0 and 0.10 ps. and a fourth resonant process centered at 5.25×10^3 GHz (175 cm^{-1}) (fig. 10a)³⁷. The first relaxation process, I, is assumed to correspond to be either a cooperative process or the making and breaking of hydrogen bonds with an activation energy of 4 Kcal/mol in the range from 1 to 20°C and 2.9 Kcal/mol in the range of 42 to 94°C. As the relaxation time is comparatively slow, a better explanation of this relaxation may be the transfer of the activation of one molecule in a tetrahedral structure to the other. This process is described by the Debye equation because the activation has the same barrier for each of the four sites.

The second process, II, follows Davidson-Cole distribution and is interpreted as arising from the rotation of single water molecules that are not hydrogen-bonded at a given instant of time. It corresponds to about 3.6% of the orientation polarization and is assumed to involve only about 3% of the volume. The center frequency for this process is at 159.2 GHz. The third process, III, is assumed to be associated with the vibrational relaxation of the hydrogen bonds. The relaxation time is 100 fs and the corresponding frequency is about 59 cm^{-1} (1.77×10^3 GHz). This process may be associated with the

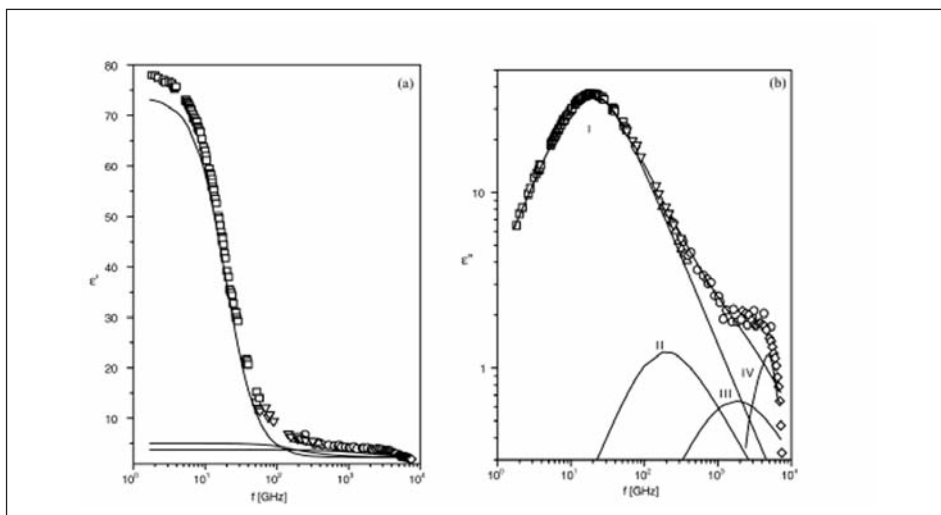

Fig. 10. (a) The spectra of water at 25°C. (b) The spectra of water at 25°C, See following text for explanation of I, II, III,IV³⁷

intermolecular energy transfer or the energy dissipation through the interaction between the O-H stretch modes. Another possibility may arise partly from the weak 60 cm^{-1} ($1.8 \times 10^3\text{ GHz}$) band due the hydrogen bond bending and/or from a weak 30 cm^{-1} ($9 \times 10^2\text{ GHz}$) band as reported in the literature.

The fourth process, IV, is centered at $5.24 \times 10^3\text{ GHz}$, and arises from the translational modes originating from the stretching of the hydrogen bonds. It involves fluctuations both in the dipole moment and the polarizability as the band is seen in the Raman spectra, too. The lowest frequency process is pure Debye and interpreted as arising from the activation of the water molecule, from one of the four sites surrounding a central molecule, to a neighboring unoccupied site³⁷.

The absorption coefficient and ϵ increase with temperature up to about 50°C , and the correlation coefficient decreases with temperature. Above 50°C and a frequency of 100 cm^{-1} ($3 \times 10^3\text{ GHz}$) the absorption levels off. This is consistent with breaking of O-H bonds and the freeing of more water molecules to rotate with the applied field³⁷.

Permittivity of Sodium Chloride Solutions:

Biological systems have high water content containing ions. Peyman suggests that at frequencies above 100 MHz, the interaction of microwaves with biological tissues is dependent on the aqueous and ionic content. He has investigated the complex permittivity of salt solution³⁶. The dielectric relaxation of behavior of electrolyte solutions is a key parameter in determining the solvent dynamics. It also has an effect on charge transport, chemical spectation, and other thermodynamic properties of solutions. Peyman presented the changes in static permittivity (fig. 11) and ionic conductivity (fig. 12) as a function of concentrations c (mol/L) for different NaCl solutions.

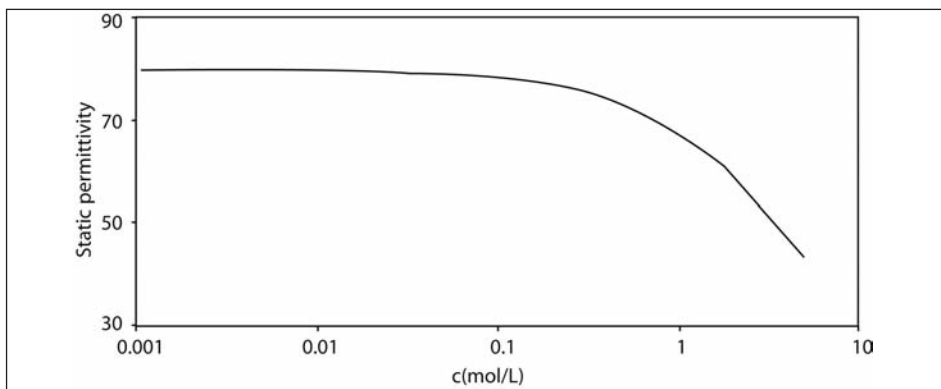

Fig. 11. Static permittivity as a function of concentrations c (mol/L) for different NaCl solutions at 20°C ³⁶

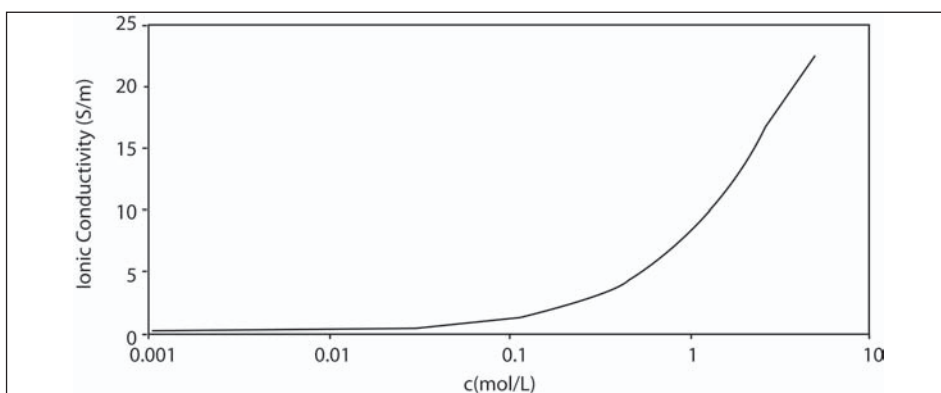

Fig. 12. Ionic conductivity (σ), as a function of concentrations c (mol/L) for different NaCl solutions at 20°C ³⁶

For dielectric measurements of NaCl, Peyman fitted the data to Cole-Cole model (Eq. 7) for higher concentrations ($c > 0.5$ mol/L) and suggested that Debye model would be a better model for lower concentrations. For $\alpha = 0$ Cole-Cole model becomes Debye model for a process with a single relaxation time. Available dielectric data for aqueous solutions are limited and not always reliable. This is due to technical difficulties associated with the measurement of the complex permittivity spectrum of solutions³⁸.

For many processes in pure water the relaxation time of interest is the constant characterizing the formation of “mobile water”. This is the time that a water molecule goes through from the ground state to the active state, which is determined by water’s average number of hydrogen bonds. In the case of an aqueous solution, this time is affected by the entry in the solvation shell of the cation and of the anion (fig. 13)³⁸.

The residence time of water in the first solvation shell of Cl^- is around 4 ps and is longer for Na^+ ^{33,39}. It can be assumed that orientation of water around the anion is dominated by $\text{HO}\cdot\text{H}\cdot\text{Cl}^-$ hydrogen bonds. Therefore, even if the hydrogen bond of the water molecule is broken, the bond between solvation shell and water still affect the dielectric properties.

On the other hand, in the first solvation of Na^+ water molecules are radially oriented with less angular distribution. If the bond between the bulk and first solvation shell of Na^+ is broken, net moments will cancel. Figs. 13 and 14 present ionic solvation and solvent dynamics. Heinzinger work simulations illuminated some of the properties of aqueous solutions. He collected the data of angular distributions of water molecules around ions.

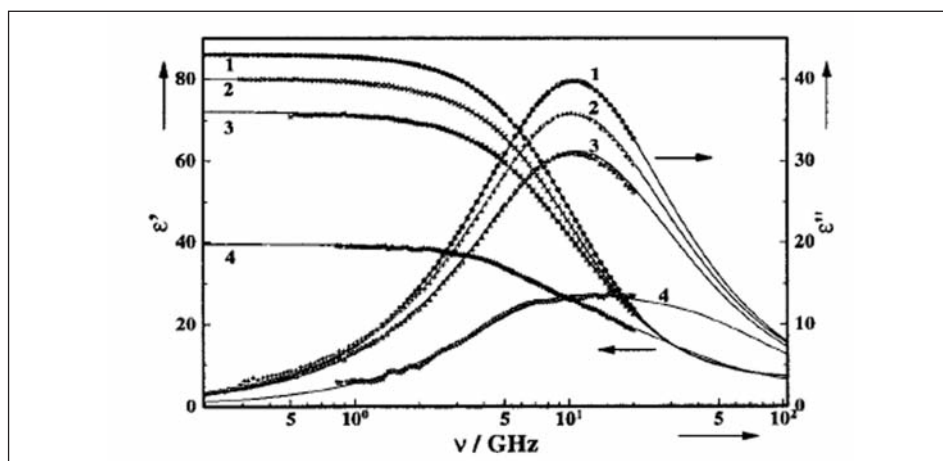

Fig. 13. Dielectric dispersion, $\epsilon'(\nu)$, and loss spectrum, $\epsilon''(\nu)$, of NaCl solutions in water at 5°C: spectrum 1, pure water; spectrum 2, $c=0.400 \text{ mol dm}^{-3}$; spectrum 3, $c=0.990 \text{ mol dm}^{-3}$; spectrum 4, $c=4.643 \text{ mol dm}^{-3}$. Experimental spectra 1-3 (symbols) are fitted to a single Cole-Cole equation (lines); spectrum 4 is fitted to a superposition of two Debye processes³⁸

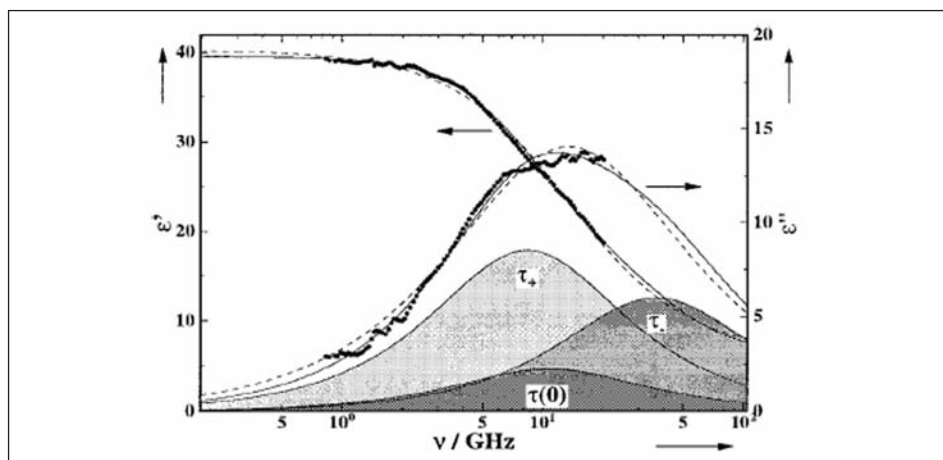

Fig. 14. Experimental dielectric dispersion, $\epsilon'(\nu)$, and loss data, $\epsilon''(\nu)$, of a $4.643 \text{ mol dm}^{-3}$ NaCl solution in water at 5°C (symbols) and the spectrum predicted by the three-state model for $\tau(c)$ (solid line). Also indicated are the predicted loss contributions of the free water ($\tau(0)$) and of the water surrounding the cations (τ_+) and the anions (τ_-). The broken line represents the Cole-Cole fit to $\hat{\epsilon}(\nu)$ ³⁸

Water and Proteins

Water performs important functions in determining the shape and function of proteins. Water is attracted to hydrophobic amino acids, and repelled by hydrophilic amino acids. The regions in water that are affected hydrophobic force can form stable water structures that exclude solutes and micro spheres out to distances of several hundred microns⁴⁰. In proteins the hydrophilic regions repel water and the protein folds so as to exclude water from these regions. Water is also hydrogen bonded to other regions and forms a diffuse shell around the protein that increases its size and decreases its mobility in way that is similar to that previously described for simple ions. Water may also be folded into the interior of a protein so that it is not in contact with the bulk water in which is dissolved. Some of this enclosed water is bound to fixed positions in the protein structure and some appears to be free to tumble. The bound water is important in determining the shape of the proteins and therefore their biological function. Additionally, the bound water H bonds may be dynamically connected to each other forming water structures that connect water molecules that are bonded to specific sites on the protein. The dynamic nature of the water structures provides flexibility to the proteins. Water is also important in catalyzing the chemical reactions with oxygen that provide the energy for living systems⁴¹.

The dielectric properties of amino acids and proteins are hard to measure in a dilute solution of water with its high dielectric constant. As a result, the measurements are tabulated decrements of $\delta\epsilon'$ and $\Delta\epsilon''$ where the decrements are defined by $c\delta = \epsilon_s - \epsilon'$ and c is the concentration and ϵ_s is the static dielectric constant. Similarly, the absorption increment is given by $c\Delta\epsilon'' = \epsilon'' - \epsilon_w'' - \epsilon_p'' - \epsilon_c''$ where ϵ_w'' and ϵ_p'' are the contributions from the bulk water and the protein relaxations and ϵ_c'' is the contribution from the ionic conductivity. A table of some of these values for amino acids is given by Grant¹.

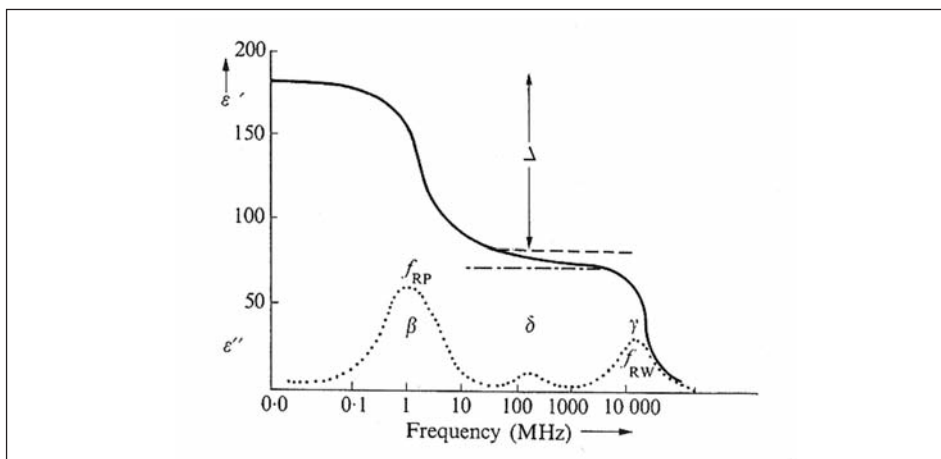

Fig. 15. Dielectric dispersion curve of an aqueous solution of hemoglobin. The curve shows three separate dispersion regions. f_{RP} : relaxation frequency of protein molecule. f_{RW} : relaxation frequency of water molecule. Δ : dielectric increment. The relaxation time, $\tau = (2\pi \text{ times the relaxation frequency})^{-1}$. - - -, β -dispersion extrapolated to high frequencies, -.-.- γ -dispersion extrapolated to low frequencies¹

The β relaxations associated with rotation of the molecules are typically in the low megahertz region. The δ relaxations are associated with motion of the bound water molecules and γ relaxations are associated with the free water. It is to be noted that the rapid exchange of water molecules at the surface of the amino acids and proteins allows for relatively free rotation of the acid or protein.

Properties of water in Magnetic Fields

Water is a diamagnetic fluid. This means that water has no permanent magnetic moment. The induced dipole moment per unit volume $\vec{M} = \chi\vec{H}$ where χ is the magnetic susceptibility and H is the magnetic field strength. For diamagnetic materials χ is negative and for water the susceptibility at 296 K is approximately -90×10^{-8} A/m. Precise measurements of this value are difficult; however, careful measurements of $\frac{\chi}{\chi_{20}}$ where χ_{20} is the susceptibility at 20°C have been made⁴² and show a small, approximately linear increase with temperature. A more complete theoretical explanation of this variation is given by⁴³ and the results correspond to those that are to be expected from measurements of the index of refraction.

The magnetic flux density \vec{B} is given by

$$\vec{B} = \mu_0(\vec{H} + \vec{M})$$

where μ_0 is the permeability of free space. The force \vec{F} exerted by a magnetic field on a charge q moving with a velocity v is given by

$$\vec{F} = q(\vec{v} \times \vec{B})$$

The force on a material with a magnetic susceptibility χ is given by

$$\vec{F} = \frac{\chi}{\mu_0} \vec{\nabla} B \bullet \vec{B}$$

Diamagnetic materials move out of high field regions into regions with smaller fields. For large fields and large field gradients, 8T and $B = 50T/m$, Ueno⁴⁴ has shown that the level of water can be depressed as shown in fig. 16. The decrease in water level is given by

Where ρ is mass per unit volume, g is gravitational constant.

$$h = \chi \mu_0 H^2 / 2 \rho g$$

Similar experiments with various concentration of NaCl showed that the level change in water declined as the concentration of NaCl is increased. It is reported that magnetic fields cause changes in the conductivity of electrolyte solutions and the change will depend on the nature of ions in the solutions and will be proportional to the thickness of the hydration shell around the ions, which is directly related to the structure of water^{44,45}. Iwasaka⁴⁶ investigated the effect of strong magnetic fields on the near-infrared spectrum on water (fig. 17). He reported the formation of hydrogen bonds in water molecules and peak wave length shift to longer wavelength in the near infrared spectrum of water around 1900 nm (fig. 18).

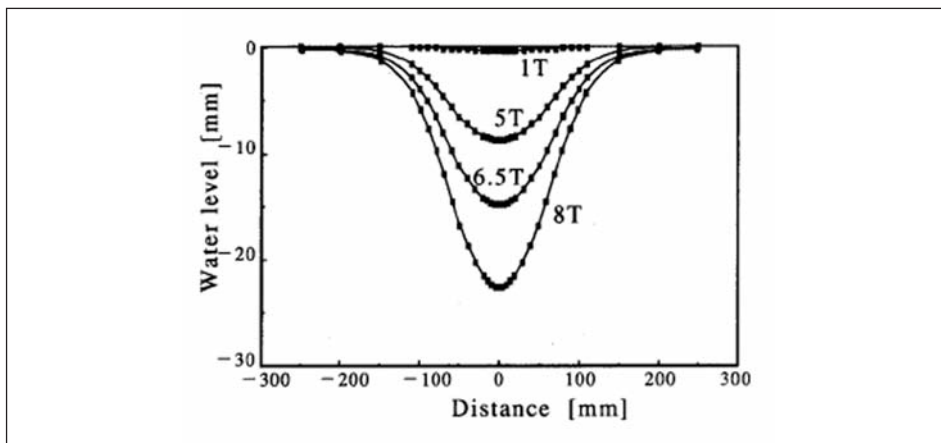

Fig. 16. Formation of water-wall in magnetic fields up to 8 T. The curves are obtained⁴⁴ by the equation $h = \chi \mu_0 H^2 / 2 \rho g$

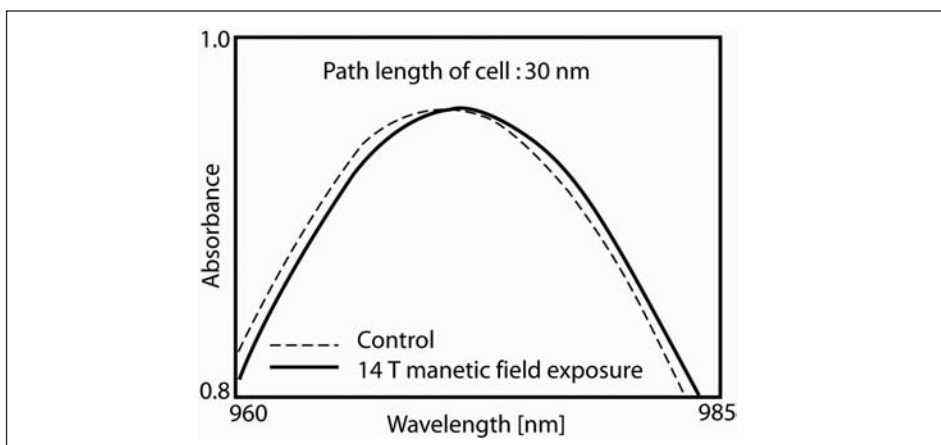

Fig. 17. Effects of a 14 T magnetic field on near-infrared spectrum of water at 900–1000 nm. (Optical length is 30 mm)⁴⁶

The clusters of water molecules that surround an ion as shown in fig. 6 provide a possible means for shielding an ion from the thermal environment of colliding molecules that could lead to the kind of isolation required to explain the effects of the experiments by Zhadin⁷, and possibly provide a structure for containing the molecules for the theory of Del Giudice⁴⁷.

Hemoglobin

Hemoglobin is an iron-containing protein capable of binding oxygen molecules found in red blood cells. Oxygen plays an important rôle in configuring the molecular structure

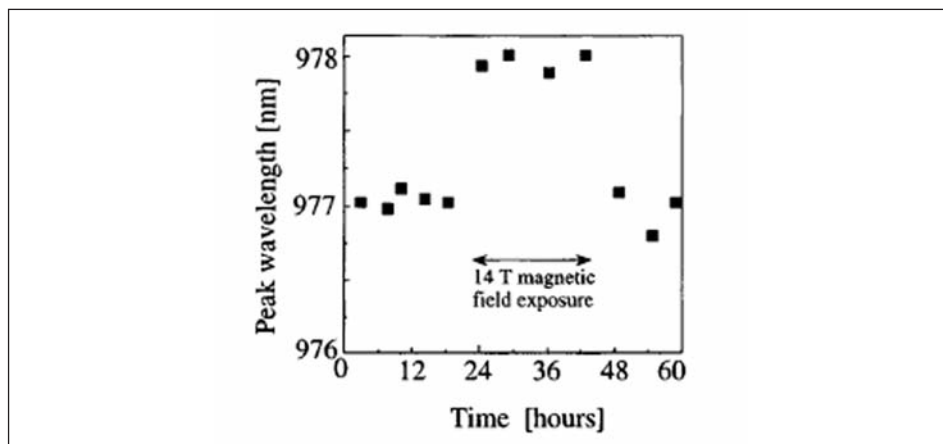

Fig. 18. Effects of a 14 T magnetic field on the peak wavelength of water at 978–980 nm. (Optical length is 10 mm)⁴⁶

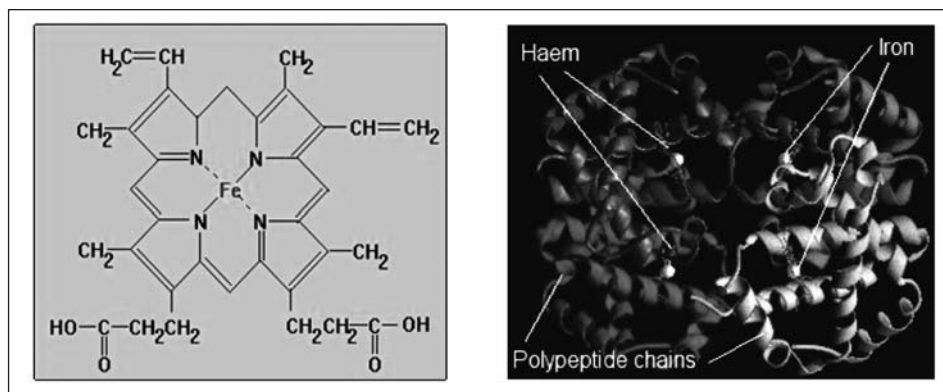

Fig. 19. The structure of hemoglobin⁴⁸

of hemoglobin (fig. 19). Hemoglobin without oxygen is *deoxyhemoglobin* and with the oxygen is called *oxyhemoglobin*. The structure determines the magnetic properties of red cells.

The physical and chemical behavior of hemoglobin with oxygen and without oxygen changes so drastically that it attracts attention. One example of this difference occurs in X-ray diffraction patterns and the optical dichroism of the two forms⁴⁹. Schlecht⁵⁰ investigated the dielectric properties of hemoglobin in the frequency range for 100 KHz to 15 MHz with different degrees of oxygenation. He could not find the variation as reported by Takashima and Lumry⁴⁹.

Takashima⁴⁹, studied the dielectric properties of hemoglobin using 1 MHz frequency under progressive oxygenation. He found that the dielectric increment curve had two distinct maxima which would cause increases and decreases in the dipole moment of the

hemoglobin molecule. The effect of adding oxygen at higher temperatures is to narrow down the two peaks to one peak.

A *metamagnetic* system is one in which the spin flop region of the phase diagram has zero area. When anisotropy becomes so large due to crystal field or anisotropy being equal to the antiferromagnetic exchange field, the moments go over from an antiferromagnetic alignment to a saturated paramagnetic alignment. The diamagnetic-paramagnetic switching activity of hemoglobin (HB) on oxygenation is similar to this metamagnetic switch^{50, 51}.

In a hemoglobin molecule the iron is located at the middle of the heme. Nitrogen of the porphyrin ring takes four of the coordination position. Sixth coordination position is taken up by a ligand. Fabry suggests that if in the dry deoxygenated form of hemoglobin sixth coordination position is occupied by a water molecule, it should be firmly bound⁵².

Pauling and Coryell studies suggest that *deoxyhemoglobin* and *methemoglobin* are paramagnetic, *oxyhemoglobin* and *carboxyhemoglobin* are diamagnetic. In hemoglobin the iron is present as a ferrous ion with four unpaired electrons. Fabry suggests that in solutions of deoxyhemoglobin and methemoglobin there is decrease in proton relaxation time compared to solutions of the diamagnetic forms. This would be due to the paramagnetic ions being in contact with the water molecules. However, Fabry's findings suggest that in deoxyhemoglobin solution sixth coordination position is either not occupied by water, or if there is water it is so firm that there is no exchange with the bulk of the water molecules.

A theoretical model for magnetic susceptibility of whole blood is taken from Spees⁵³. In these calculations 'cgs' units will be used. 'Susceptibility' will refer to "volumetric magnetic susceptibility." In this model, susceptibility of red blood cells will be considered with the contribution of three major components of the erythrocyte: *diamagnetic water*, *the diamagnetic component* of hemoglobin (Hb), and the *paramagnetic* contribution of Fe₂ in deoxyHb. The contribution of paramagnetic dissolved O₂ will be considered minor and will not be included.

$$\chi_{RBC} = (1 - n_{Hb} \cdot v_{M,Hb}) \cdot \chi_{H_2O} + n_{Hb} \cdot (M_{Hb} \cdot \chi_{g,protein} + (1-Y) \cdot \chi_{M,deoxyHb})$$

Y : Fraction of hemoglobin that is present in the form of oxyHb,

n_{Hb} : Total intracellular Hb concentration, 5.5 x10⁻⁶ mol/mL

χ_{g,protein} : Gram susceptibility, diamagnetic contribution of Hb protein:
-0.587x10⁻⁶ mL/g

χ_{H₂O} : Volume susceptibility of water -0.719x10⁻⁶

M_{Hb} : Molecular weight of deoxyHb 64,450 g/mol

v_{M,Hb} : Molar volume of Hb in solution, 48,277 mL/mol

The paramagnetic contribution to the molar susceptibility of deoxyHb, χ_{M,deoxyHb} is calculated as a function of temperature as follows:

$$\chi_{M,deoxyHb} = 4 \cdot \left(\frac{N \mu_{eff}^2}{3 k_B T} \right) = 48,082 \times 10^{-6} \left(\frac{mL}{mol} \right).$$

Using a value for μ_{eff} the average magnetic moment of hemoglobin Fe²⁺ measured for whole blood equals to 5.46 Bohr magnetons/Heme. k_B is the Boltzmann constant, N is Avogadro's number. T is the temperature of the sample in Kelvin.

The model of the susceptibility of the erythrocyte is simplified to

$$\chi_{RBC} = -0.736 \cdot 10^{-6} + (1 - Y) \cdot 0.264 \cdot 10^{-6}.$$

This equation predicts magnetic susceptibility of oxygenated red Blood Cell as -0.736 ppm. It also gives the difference between deoxygenated and oxygenated red blood cells as

$$\Delta\chi = 0.264 \text{ ppm},$$

Summary and Conclusion

In this chapter we have reviewed some of the characteristics of water molecules and the structures that they form. Recent simulations provide some insight into the electrical properties, including the high mobility of both H^+ ions and OH^- ions and the large dielectric constant. They also provide models for structures of the water molecules that surround some of the more common biologically important ions such as Na^+ and Cl^- and they give some insight into their electrical properties such as mobility and dielectric constants. The characteristic of the water molecules associated with complex biological ions and molecules are less completely described as are their important rolls in protein folding and their interactions with one another. The effects of water molecules on the magnetic properties of biological ions and molecules are less completely explored. The possibility that water molecules can form structures that can isolate ions or internal parts of biological ions from the thermal bath to the extent that they have long coherence times for magnetic interactions still needs to be explored in more detail.

Acknowledgement

The authors appreciate the financial support from University of Colorado and the Bernard Gordon Prize.

References

1. Grant EH, Sheppard RJ, South, GP. Dielectric behaviour of biological molecules in solution. Clarenton Press, 1978; 144-60.
2. Marechal Y. The hydrogen bond and the water molecule: the physics and chemistry of water, aqueous and bio-media. Elsevier Science, 2007.
3. Beers GJ. Biological effects of weak electromagnetic fields from 0 Hz to 200 MHz: a survey of the literature with special emphasis on possible magnetic resonance effects. Magn Reson Imaging 1989; 7 (3): 309-31.
4. Barnes SF. Interaction of DC and ELF electric fields with biological materials and systems. In: Barnes SF, Greenbaum B. Handbook of biological effects of electromagnetic fields, 3rd Edition, Boca Raton FL: CRC Press, 2006; 5.
5. Liboff A. The ion cyclotron resonance hypothesis. In: Barnes SF, Greenbaum B. Handbook of biological effects of electromagnetic fields, 3rd Edition, Boca Raton FL: CRC Press, 2006; 95.
6. Yinnon Carmi A, Yinnon, Tamar A. Domains in aqueous solutions: theory and experimental evidence. World Scientific Publishing Company, Modern Physics Letters B, Vol. 23, 2009: 1959-73.
7. Zhadin MN, Novikoff VV, Barnes FS, *et al.* Combined action of static and alternating mag-

- netic fields on ionic currents in aqueous glutamic acid solution. *Bioelectromagnetics* 1998; 1 (19): 41-5.
8. Pazur A. Characterisation of weak magnetic field effects in an aqueous glutamic acid solution by non-linear dielectric spectroscopy and voltammetry. *Biomagn Res Technol* 2004; 2: 8.
 9. Comisso N, Del Giudice E, De Ninno A, *et al.* Dynamics of the ion cyclotron resonance effect on amino acids adsorbed at the interfaces. *Bioelectromagnetics* 2006; 27: 16-25.
 10. Giuliani L, Grimaldi S, Lisi A, *et al.* Action of combined magnetic fields on aqueous solution of glutamic acid: the further development of investigations. *Biomagn Res Technol* 2008. 6: 1.
 11. Kyte J. *Structure in protein chemistry*. 2nd edition. New York: Garland Pub, 2007.
 12. Atkins WP. *Physical Chemistry*. New York: WH Freeman & Co, 1994.
 13. Ladd M. *Introduction to physical chemistry*. 3rd edition. Cambridge UK: Cambridge University Press, 1998.
 14. Barrow GM. *Physical chemistry*. New York: McGrawHill Book Company, 1961; 233 (figs 6-9).
 15. Keutsch FN, Saykally RJ. Water clusters: untangling the mysteries of the liquid, one molecule at a time. *Proc Nat Acad Sci US PNAS* 2001; 98 (98): 10533-40.
 16. Ludwig R. Water: from cluster to the bulk. *Angew Chem Int Ed, Engl* 2001; 40(10): 1808-27.
 17. Chaplin MF. A proposal for the structuring of water. *Biophys Chem* 2000; 83 (3): 211-21.
 18. Liu K, Brown MG, Carter C, *et al.* Characterization of a cage form of the water hexamer. *Nature* 1996; 381: 501-3.
 19. Narten AH, Thiessen WE, Blum L. Atom pair distribution functions of liquid water at 25°C from neutron diffraction. *Science* 1982; 217: 1033-4.
 20. Kuhs WF, Lehmann MS. The structure of the ice Ih by neutron diffraction. *J Phys Chem* 1983; 87 (21): 4312-3.
 21. Kim K, Jordan KD, Zwier, TS. Low-energy structures and vibrational frequencies of the water hexamer: comparison with benzene-(H₂O)₆. *J Am Chem Soc* 1994; 116 (25): 11568-69.
 22. Eigen M, De Maeyer L. Self-dissociation and protonic charge transport in water and ice. *Proc R Soc Lond. Series A, Mathematical and Physical Sciences* 1958; 247 (1251): 505-33.
 23. Eisenberg D, Kauzmann, W. *The structure and properties of water*. Oxford: Clarendon Press, 2005.
 24. Sceats MG, Rice SA. In: Franks F, ed. *Water: a comprehensive treatise*. New York: Plenum Press, 1982; Vol 7.
 25. Burnham CJ, Petersen MK, Day TJJ, *et al.* The properties of ion-water clusters. II. Solvation structures of Na⁺, Cl⁻, and H⁺ clusters as a function of temperature. *J Chem Phys* 2006; 124 (2): 024327-024327-9.
 26. Hartke B, Oharvat A, Reich M, *et al.* Experimental and theoretical investigation of microsolvation of Na⁺-ions in the gas phase by high resolution mass spectrometry and global cluster geometry optimization. *J Chem Phys* 2002; 116: 3588-13.
 27. Carignano MA, Karlstrom G, Linse P. Polarizable ions in polarizable water: a molecular dynamics study. *J Phys Chem B* 1997; 101: 1142-7.
 28. Skinner J.L. Following the motions of water molecules in aqueous solutions. *Science* 2010; 328: 985-6.
 29. Ji M, Odellius M, Gaffney KJ. Large angular jump mechanism observed for hydrogen bond exchange in aqueous perchlorate solution. *Science* 2010; 328: 1003-5.
 30. Tielrooij KJ, Garcia-Araez N, Bakker HJ. Cooperativity in ion hydration. *Science* 2010; 328: 1006-9.
 31. Vlaev L, Tavlieva M, Barthel J. Temperature and concentration dependences of the electrical conductance, diffusion and kinetic parameters of sodium selenite solutions in ordinary heavy water. *J Solutio Chem* 2006; 36: 446-65.
 32. Pohl HA. *Dielectrophoresis the behavior of neutral matter in nonuniform electric fields*. Cambridge: Cambridge University Press, 1978.
 33. Buchner C, Barthel R, Stauber J. The dielectric relaxation of water between 0°C and 35°C. *Chemical Physics Letters* 1999; 306: 57-63.
 34. Ellison WJ, Lamkaouchi K, Moreau JM. *Water: a dielectric reference*. *Journal of Molecular Liquids* 1996; 68: 171-279.
 35. Deb Nipamanjari, Mukherjee Asok K. Dielectric constant of water from free energies of H-bond formation in (H₂O)_n clusters. *Spectrochimica Acta Part A: Molecular and Biomolecular Spectroscopy* 2008; 462: 370-3.

36. Peyman A, Gabriel C, Grant EH. Complex permittivity of sodium chloride solutions at microwave frequencies. *Bioelectromagnetics* 2007; 28: 264-74.
37. Vij JK, Simpson DRJ, Panaria OE. Far infrared spectroscopy of water at different temperatures: GHz to THz dielectric spectroscopy of water. *Journal of Molecular Liquids* 2004; 112: 125-35.
38. Buchner R, Hefter GT, May PM. Dielectric relaxation of aqueous NaCl solutions. *J Phys Chem* 1999; 103 (1): 1-9.
39. Ohtaki H, Radnai T. Structure and dynamics of hydrated ions. *Chem Rev* 1993; 1157-204.
40. Zheng J, Chin Wei-Chun, Khijniak E, *et al.* Surfaces and interfacial water: evidence that hydrophilic surfaces have long-range impact. *Science* 2006; 127 (1): 19-27.
41. Voeikov VL, Del Giudice E. Water respiration - the basis of the living state. *WATER: A Multidisciplinary Research Journal* 2009; 1: 52-75.
42. Philo JS, Fairbank WM. Temperature dependence of the diamagnetism of water. *J Chem Phys* 1980; 72 (8): 4429-33.
43. Day EP. Equations for the Magnetic Susceptibility of water. *J Chem Phys* 1980; 72 (8): 4434-6.
44. Ueno S, Iwasaka M. Properties of diamagnetic fluid in high gradient magnetic fields. *Journal of Applied Physics* 1994; 75 (10): 7177-9.
45. Holysz L, Szczes A, Chibowski E. Effects of a static magnetic field on water and electrolyte solutions. *Journal of Colloid and Interface Science* 2007; 316 (2): 996-1002.
46. Iwasaka M. Structure of water molecules under 14 T magnetic field. *Journal of Applied Physics* 1998; 83 (11): 6459-61.
47. Del Giudice E, Fleischmann M, Preparata G, *et al.* On the "unreasonable" effects of ELF magnetic fields upon a system of ions. *Bioelectromagnetics* 2002; 23: 522-30.
48. The structure of hemoglobin available on. <http://www.elp.manchester.ac.uk>
49. Takashima S, Lumry R. Dielectric properties of hemoglobin. ii. anomalous dispersion during oxygenation. *J Am Chem Soc* 1958; 80 (16): 4238-44.
50. Schlecht P. Data on aggregation properties and dipole moments of separated alpha-chains and beta-chains of human hemoglobin from dielectric measurement between 15 MHz and 100 MHz. *Hoppe-Seylers Zeitschrift Fur Physiologische Chemie* 1970; 351 (2): 127.
51. Barret TW. The metamagnetic properties of hemoglobin. *Physics Letters A* 1982; 91 (3): 139-42.
52. Fabry TL, Reich HA. The role of water in deoxygenated hemoglobin solutions. *Biochemical and Biophysical Research Communications* 1996; 22 (6): 700-3.
53. Spees WM, Yablonsky DA, Oswood MC, *et al.* Water proton MR properties of human blood at 1.5 Tesla: Magnetic susceptibility, T1, T2, T, and non-Lorentzian signal behavior. *Magnetic Resonance in Medicine* 2001; 45 (4): 533-42.

Suggested Readings:

- Albert S, Mitchell, *et al.* Hyperpolarized ^{129}Xe T 1 in oxygenated and deoxygenated blood. *NMR in Biomedicine* 2000; 13 (7): 407-14.
- Bartoszek M, Drzazga Z. A study of magnetic anisotropy of blood cells. Elsevier Science. *Journal of Magnetism and Magnetic Materials* 1999; 196: 573-5.
- Beaugnon E, Toumier R. Levitation of organic materials. *Nature* 1991; 349 (7): 470.
- Bemski G, Novak M, Symko OG. Magnetization of hemoglobin and myoglobin below 1-K. *Physics Letters A* 1982; 99 (1): 62-4.
- Bertoluzza A, *et al.* *Italian Journal of Biochemistry* 1987; 36 (57A).
- Bertoluzza A, *et al.* The role of water in biological systems. *Journal of Molecular Structure* 1993; 297: 425-37.
- Bhattacharyya K. Nature of biological water: a femtosecond study. 25, s.l.: Royal Society of Chemistry, Cambridge, ROYAUME-UNI (1996) (Revue), 2008, Chemical communications, pp. 2848-2857.
- Cano M, *et al.* Computer simulation of magnetic properties of human blood. *Chemical Physics Letters* 2006; 432 (4-6): 548-52.
- Del Giudice E, Preparata G, Fleischmann M. QED coherence and electrolyte solutions. *Journal of Electroanalytical Chemistry* 2000; 482(2): 110-6.
- Fischer WB, Fedorowicz A, Koll A. Structured water around ions - FTIR difference spectroscopy and quantum-mechanical calculations. *Physical Chemistry Chemical Physics* 2001; Vol. 3 (19): 4228-34.

- Fourkas JT, *et al.* Supercooled Liquids: Advances and Novel Applications. Washington DC: ACS Books, 1997.
- Halle B. Protein hydration dynamics. 1217Phil. Trans R Soc Lond. B 2004; 359: 1207-24.
- Isaacs ED, *et al.* Covalency of the Hydrogen Bond in Ice: A Direct X-Ray Measurement. Physical Review Letters 1999; 82 (3): 600.
- Jeffrey GA, Saenger W. Hydrogen Bonding in Biological Structures. Heidelberg: Springer-Verlag, 1991.
- Kato M *et al.* Physics and Chemistry of Ice. [ed.] N Maeno and T Hondoh. Hokkaido: s.n., 1992. p. 83.
- Klotz IM, Kasha M, Pullman, B. Horizons in Biochemistry. New York: Academic Press, 1962, p. 523.
- Luzar A, Chandler D. Hydrogen-bond kinetics in liquid water. Nature 379: 55-7.
- Mishima O, Stanley HE. The relationship between liquid, supercooled and glassy water. Nature 396: 329-35.
- Nagamine K, Shimomura K, Schultz JS, Physica B. Probing magnetism in human blood by muon spin relaxation. Proceedings of the Tenth International Conference on Muon Spin Rotation, Relaxation and Resonance, Condensed Matter, Vols. 374-5, pp. 444-7.
- Nandi N. Dielectric relaxation and solvation dynamics of water in complex chemical and biological systems. Chemical Reviews 100 (6): 2013-45.
- Pauling L, Coryell C. The magnetic properties and structure of hemoglobin, oxyhemoglobin and carbonmonoxyhemoglobin. Proc Natl Acad Sci 1936; 22: 210-6.
- Peterson SW, Levy H. A single-crystal neutron diffraction study of heavy ice. Acta Crystallogr 1957; 10: 70-6.
- Sasai M, Shiratani E. Rearrangement dynamics of the hydrogen-bond network in liquid water. Journal of Crystallographic Society of Japan 1998; 40 (1): 101-6. Language-japanese.
- Savicki JP, Lang G, Ikedasaito M. Magnetic-susceptibility of oxyghemoglobins and carbonmonoxy-hemoglobins. Preceedings of the national Academy of Sciences of the United States of America – Biological Science 81 (17): 5417-9.
- Van JC. A review of: "Water a Comprehensive Treatise Volume 7 (Water and Aqueous Solutions at Subzero Temperatures). F. Franks, ed. Preparative Biochemistry and Biotechnology. Plenum Press, 1982, Vol. 13: 175-6.
- Zborowski M, *et al.* Red blood cell magnetophoresis. Biophysical Journal 2003; 84 (4): 2638-45.

Weak low-frequency electromagnetic fields are biologically interactive

Abe R. Liboff

Center for Molecular Biology and Biotechnology, Florida Atlantic University, Boca Raton, FL, USA

Abstract

There is a need to reexamine the data used to determine biological plausibility in electromagnetic health effects. Current thinking relies on simplistic electrical engineering estimates completely at odds with reliable scientific findings. Recent studies add to the already abundant evidence indicating that ultra-weak low-frequency electromagnetic fields are biologically interactive. Work by Zhadin, especially, independently replicated at three other laboratories, has shown that ion cyclotron resonance-tuned combinations of magnetic fields (ICR) alters the physical properties of amino acids in solution. The intensity of AC magnetic fields employed in these experiments is 40 nT, approximately 3 orders of magnitude smaller than the estimates currently used in determining regulatory standards. This intensity level is also consistent with a number of remarkable DC magnetic field sensitivities observed in animals, e.g., 10-100 nT in birds and honeybees. This recent additional evidence also supports decades of experimental results indicating ICR-like interactions. Nonetheless, there has been no recognition by WHO, ICNIRP or other standards-setting agencies of the evidence demonstrating the interactive capability of low frequency fields with biological systems.

***Key words:* electromagnetic fields, low-frequency, biologically interactive**

Introduction

The question of hazard due to weak electromagnetic fields is conveniently parsed into either low-frequency (power line fields) or high-frequency (mobile phones) effects, a distinction based on the types of environmental exposures in modern society. Although there are isolated examples of potential problems arising from exposures to fields at intermediate frequencies, most of the emphasis has been on exposures to the power transmission frequencies of 50/60 Hz and to mobile telephone frequencies in the vicinity of 1GHz.

Address: Abe R. Liboff, Research Professor, Center for Molecular Biology and Biotechnology, Florida Atlantic University, Boca Raton, FL, USA - E-mail: arliboff@aol.com

An underlying theme often voiced by those reluctant to admit low-level electromagnetic exposures as potentially harmful is what is claimed to be a lack of biological plausibility. In the following we examine this question in some detail, specifically concerning the biological plausibility connected to possible hazards from exposure to magnetic fields arising from electric power transmission.

Biological Plausibility and Electromagnetic Hazard

Historically, the two main avenues exploring the question of weak-field electromagnetic (EM) hazard have been epidemiology and electrical engineering. Among the criteria used by epidemiologists to test for causation is that of biological plausibility¹. Ordinarily, biological plausibility can refer to a variety of factors, including both theoretical reasons and observational evidence. However, when it comes to the question of EM hazard, epidemiologists often assume a very narrow definition of biological plausibility, restricting such evidence to potential changes in physiological state that are in agreement with engineering calculations, thereby discounting unexplained experimental evidence to the contrary.

An excellent argument can be made that the assumptions underlying these calculations are flawed. One epidemiological assumption, stemming from the Hill criteria¹, is that of dose response. It is argued that if EM hazards are real, then there must be an increased response to increased magnetic intensity. Although this may be in agreement with estimates based on Faraday induction, predicting that potential differences will scale with higher magnetic intensities and frequencies, the biological evidence shows quite convincingly that the measurable physiological responses to low-level magnetic fields do not scale according to dose-response predictions.

Instead, a wealth of experimental evidence, stretching back decades^{2,3}, points to some other mechanism, largely manifested by intensity “windows”^{4,5}, regions of magnetic intensity that are specifically interactive to the exclusion of higher and lower intensities.

As a case in point, consider the 1997 Linet case-control study⁶, which found “little evidence” for increased risks of ALL (Acute Lymphoblastic Leukemia) for children exposed to residential 60 Hz magnetic fields. The data, presented in terms of odds ratios, were grouped into seven categories of magnetic field (Fig. 1). Despite the limited data, the grouping for fields lying between 0.4 and 0.499 μT showed, according to the report, “a significant excess incidence of ALL” in this range. However, this failed to dissuade Linet *et al*⁶ from the conclusion that there was “little evidence” of ALL risk. The reasons given for ignoring this grouping in this report were that the odds ratios were not only much lower for fields larger than 0.5 μT , but that the sum total of all the data failed to find a significant trend with increasing magnetic field intensity.

It is clear that Linet *et al*⁶, despite the fact that their data appeared to provide a *prima facie* case for a response based on intensity windows, relied solely on the incorrect assumption that EM biological interactions must always exhibit a dose-response.

Among other dubious electrical engineering assumptions made by epidemiologists in their study designs is that the response does not depend on additional field factors, such as the arrangement of combined static and time-varying fields encountered in ion resonance exposures. However, overwhelming evidence⁷ gathered since the mid eighties indicates that this type of biological effect does indeed occur.

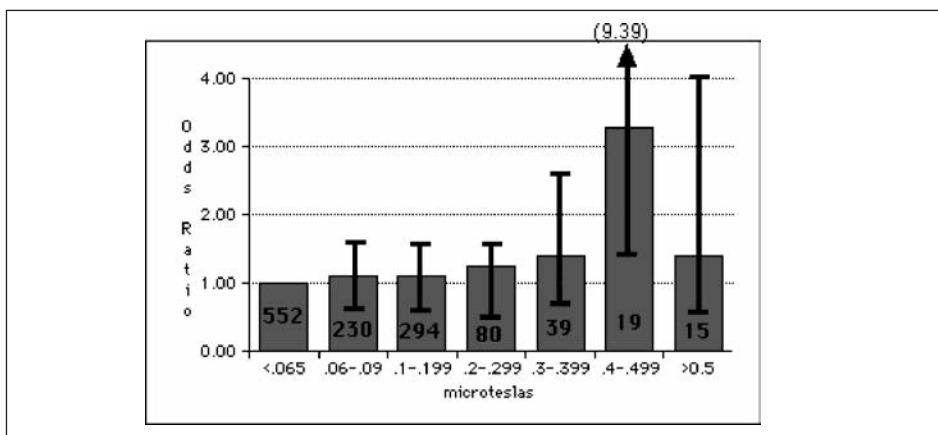

Fig. 1. Odds ratios for childhood ALL, determined by Linet *et al*⁶, as a function of residential magnetic field. The large ratios seen for fields between .4 and .499 μT , although having many less participants, are nevertheless statistically significant

Another incorrect assumption is that Faraday induction can provide a workable intensity threshold, below which signal to noise energy considerations make biological interactions impossible. Because estimates based on Faraday induction indicate that weak-field EM intensities fail to predict any meaningful electrical signal, it is argued⁸⁻¹¹ that biological interactions are physically prohibited, and consequently the question of EM human hazard fails the criterion of biological plausibility.

Each of these arguments is based on constraints arising from the theoretical application of Faraday induction to biological systems exposed to weak field low frequency magnetic fields. In some cases, these arguments are rather sophisticated¹⁰. But they all suffer when it comes to determining weak field biological plausibility because they totally disregard the lengthy pertinent experimental evidence. At best, confronted with experimental data that may conflict with their Faraday calculations, they will argue that the effects of EMFs on biological systems, if real, are very weak. Nothing could be further from the truth. Many reports indicate robust weak field sensitivities in animals, particularly for purposes of navigation.

Low-field EM Interactions in Animals

Well-documented examples of organisms which utilize the magnetic field of the earth, usually, but not always, for purposes of navigation, include birds¹², bees¹³, bacteria¹⁴, and an increasing list¹⁵ of other species, including lobsters, turtles, termites, beetles, algae, salmon, bats, mice, and even the duck-billed platypus. Similarly, other species make use of local electric fields¹⁶, notably sharks and their cousins, skates and rays. The magnetic sensitivities measured for many animals borders on the incredible. A champion racing pigeon can distinguish changes as little as 10^{-2} μT of magnetic field¹², 100 to 1000 times lower than the threshold estimates^{8,10} from engineering calculations. It has been speculated that honeybees may even be ten times more sensitive than homing pigeons, which would make the error in threshold calculation off by a factor of 10,000. For electric field detection, the scalloped hammerhead shark¹⁶ is the undisputed cham-

pion. Unlike birds and bees, where the anatomical site for magnetic detection is still in dispute, the shark senses changes in electric fields as low as $0.5 \mu\text{V}/\text{m}$ using the ampullae of Lorenzini jellylike electroreceptors located on its face.

There are important conclusions to be drawn from these examples of animal sensitivity to low level EM fields: because these animals are detecting *changes* in static field, it is entirely reasonable to think of them as capable of responding to extremely low frequencies.

In view of these extremely sensitive responses to low-level magnetic signals, previous calculations that purported to estimate ultimate sensitivities in living things, notably those by Weaver and Astumian⁸ and Adair¹⁰ must now be regarded as without merit, except insofar as they might be employed in analyzing bioresponses to much larger fields, say in excess of $100 \mu\text{T}$. It is important to note that other than the purely electric characteristics of tissues those calculations based on Faraday induction never included any biological insights or information relating to physiological receptors. Further, even without the wealth of reports that have since been published, these calculations ignored earlier experimental evidence^{2,3} that questioned whether Faraday induction is the sole means by which living things are affected by weak low-frequency magnetic fields.

Ion Cyclotron Resonance-Like Interactions

It is now established⁷ beyond any reasonable doubt that biological systems exhibit a remarkable sensitivity when exposed to magnetic field combinations that carry the ion cyclotron resonance-like (ICR-like) signature.

Many, if not most of the various experimental results indicating biological interactions arising from low level low frequency magnetic fields have displayed this highly specific ion cyclotron resonance ICR-like signature. By this we mean that in order to be interactive, ω/B , the ratio of magnetic field frequency to static magnetic field intensity, must be equal to q/m , the ratio of charge to mass of the "naked" ion (i.e., the q/m of the ion without regard to its hydration layers) that one wishes to affect. It is important to stress that in practically all such cases the ICR frequency is used as a means of obtaining responses not observed at other frequencies. Thus, in one type of experiment, a number of exposures at different magnetic frequencies ω are applied and the responses compared.

Fig. 2 is a typical result¹⁷ obtained from this type of study, showing the frequency dependent response of IGF-II (insulin like growth factor) in cell culture that peaks at the Ca^{2+} ICR resonance frequency. In such experiments, one can regard the response as being "tuned" to the ICR frequency.

In another type of ICR experiment, the effects of exposure to a resonance field tuned to specific ions have resulted in sharp changes from normal responses. A good example¹⁸ is found in planaria (Fig. 3), where exposure to the Ca^{2+} ICR resonance frequency results in a 48-hour delay in the rate of cephalic regeneration. On the other hand, for the same system, exposure to the K^+ ICR frequency does not affect regeneration time.

In spite of these and other similar experiments⁷, many investigators have rejected¹⁰ or ignored¹⁹⁻²¹ the extensive work supporting weak-field biological interactions. For example, Ahlbom *et al*²¹ are categorically incorrect when they write "There are no reproducible laboratory findings demonstrating biological effects of magnetic fields below $100 \mu\text{T}$ ".

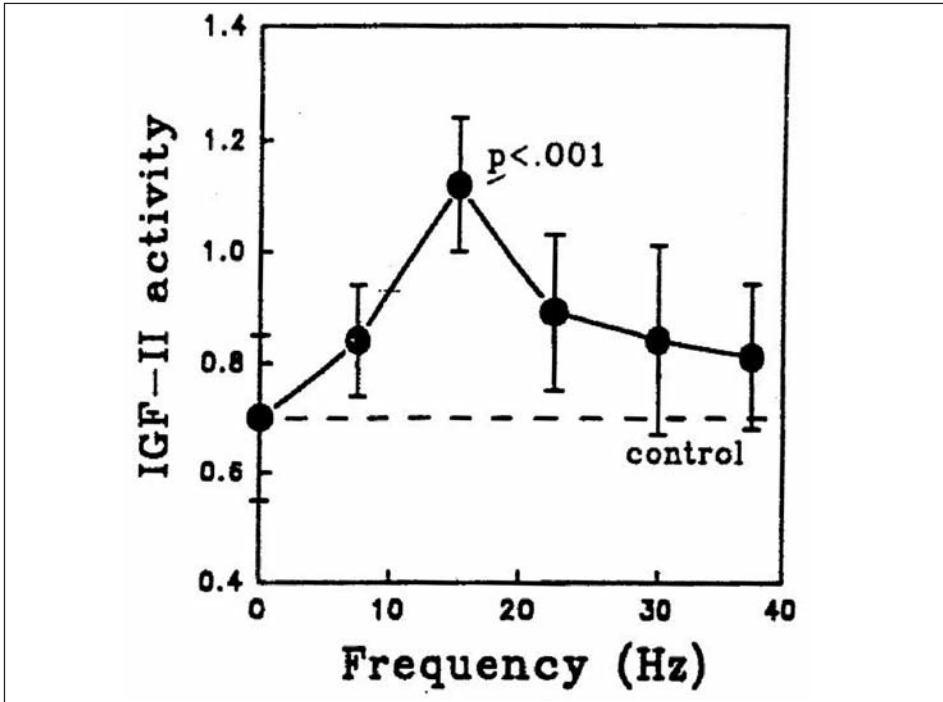

Fig. 2. The peak in IGF-II expression for human osteosarcoma bone cells exposed to combined magnetic fields occurs when the field is tuned to the Ca^{2+} ICR frequency¹⁹

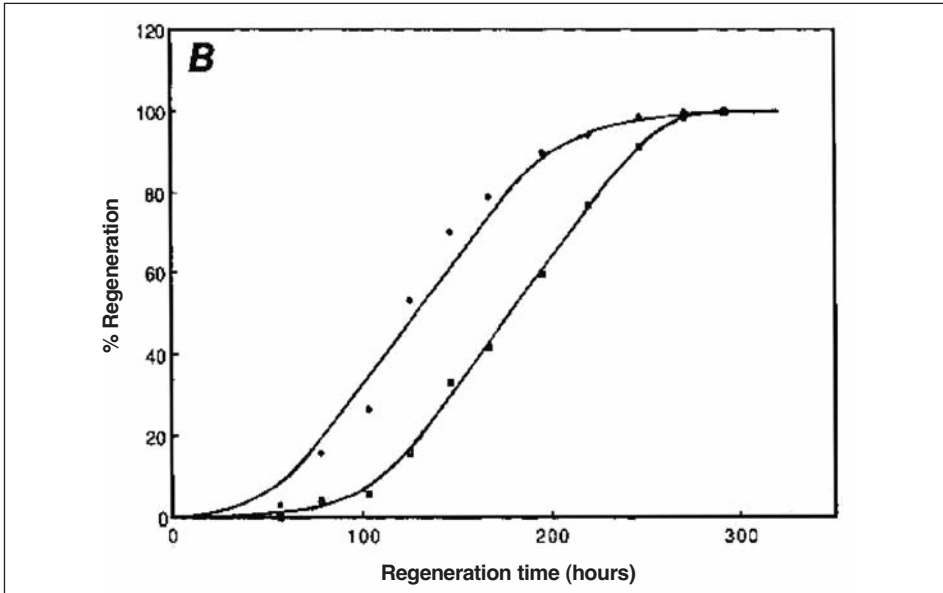

Fig. 3. Planaria exposed to the Ca^{2+} ICR magnetic field combination (right-hand curve) take far longer (48 hours) to regenerate than those that are not exposed²⁰

Often, the reason given for denying pertinent ICR evidence is that this mechanism is physically impossible in living tissue for the frequencies that are claimed to be effective. Those that make this claim clearly confuse scientific *observation* with scientific *explanation*. The fact is that there is absolutely no question that many biological systems (perhaps all) react profoundly to magnetic field combinations tuned to the ICR signature. What is also a fact is that this is true despite the lack of a tenable mechanism to explain this interaction. The scientist, faced with choosing between well-replicated observations and contrary calculations based on existing theory, must always opt for the former.

In any event, under this single guiding ICR-like signature, an extensive variety of different experimental observations have been repeatedly reported. We list as follows five categories that bear this experimental signature. The one remarkable fact is that although the following five observational categories seemingly are unconnected, they are all distinguished by exposures to combined magnetic fields that are first tuned to ion cyclotron resonance:

Physiological responses. In more than two dozen independent experiments, reproducible effects have been observed in a wide variety of seemingly disparate biological model systems⁷. These systems include:

- bone and cartilage growth
- cell culture
- rat behavior
- diatom motility
- insulin growth factor
- regeneration in planaria
- snail opioid analgesia
- plant growth

In some of these cases responses were observed for AC field strengths as little as 10 μT .

*Medical applications*²². Two applications employing ICR exposures (Ca^{2+} and Mg^{2+}) have been approved by the US Food and Drug Administration (FDA), one to treat bony nonunions and the other as an adjunct in enhancing spinal fusion (DJ Orthopedics, ReAble Corporation). Since 1987, hundreds of thousands of patients have been successfully treated in this manner.

Parametric resonance. This type of response, originally predicted by Lednev²³, was observed by Shuvalova and Lednev²⁴ (phosphorylation of myosin), then expanded upon by Blanchard and Blackman²⁵ (neurite outgrowth) and Jerman's group²⁶ (bioluminescence of dinoflagellates) in experiments ranging down to magnetic intensities of 2 μT . Notable in this class of experiments is the resonance-like dependence on AC magnetic intensity, lending support to much earlier reports^{2,3} of enhanced responses within intensity windows.

Amino acid conductance in solution. In an experiment first performed by a group led by Zhadin²⁷ it was demonstrated that exposing polar amino acids in solution to ICR-like magnetic field combinations sharply increases the conductivity, but only for AC intensities that are vanishingly small, of the order of 50 nT. These results have been replicated, with increasing precision, in at least three other laboratories²⁸⁻³¹. For one of these

replications fig. 4 shows the results of four repeated experimental runs³¹ where the conductivity in each case becomes discontinuous at the ICR frequency. These results, indicating a biochemical effect due to ultra small magnetic intensities, cannot be explained on the basis of Faraday induction.

Protein hydrolysis. Most recently, in a variation of the Zhadin experiment, it has been reported³² that certain proteins in solution can be hydrolyzed (broken into their constituent amino acid components) when exposed to ultra-small 50nT ICR magnetic fields. The same group has also published³³ evidence showing that low intensity ICR magnetic fields are effective in degrading Ehrlich Ascites cancer in mice (see fig. 5). This work has yet to be replicated in other laboratories.

Each of these five seemingly separate types of observed results are, in actuality, intimately related. All of these effects are only observed when the directions of the simultaneously applied static and time-varying magnetic fields are collinear and the frequencies are specifically tuned to the precise charge to mass ratio of certain ions under the ICR signature. These reports often refer to the ICR exposures as “combined magnetic

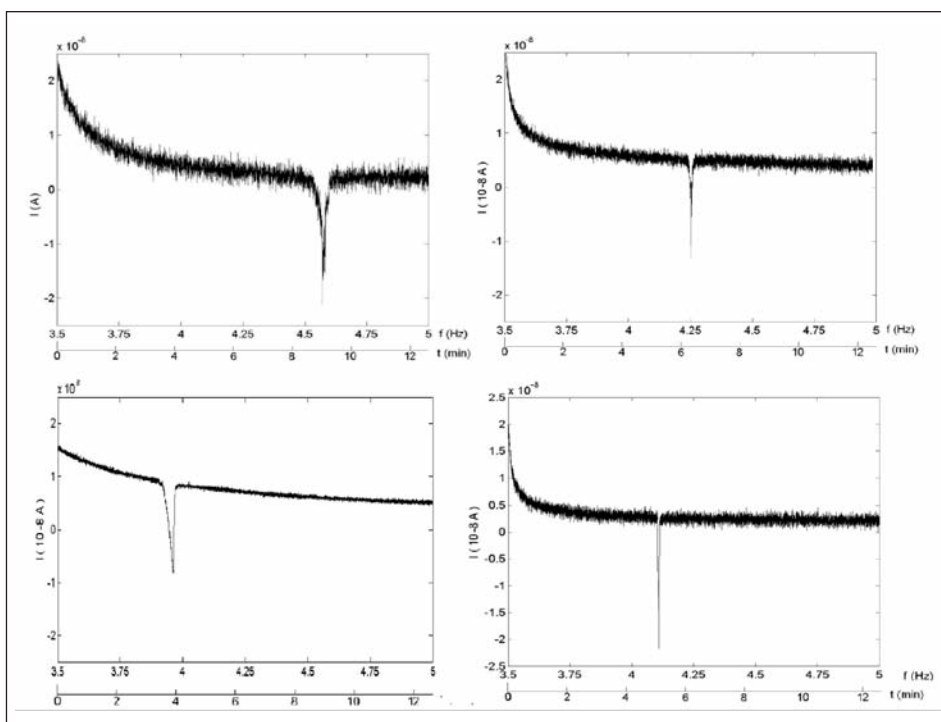

Fig. 4. Four typical behaviors³² of ionic electrolytic current as a function of time and of the corresponding frequency, for a solution of glutamic acid at pH 2.85. The solution is simultaneously exposed to a static magnetic field flux density of 40 μ T and a parallel alternating magnetic field having a flux density of 40 nT. The peaks, superposed on the smooth decreasing ionic current, appear at the cyclotron resonance frequency corresponding to the charge to mass ratio of the glutamic amino acid ion. The horizontal axis in each case indicates both magnetic field frequency and ramp time

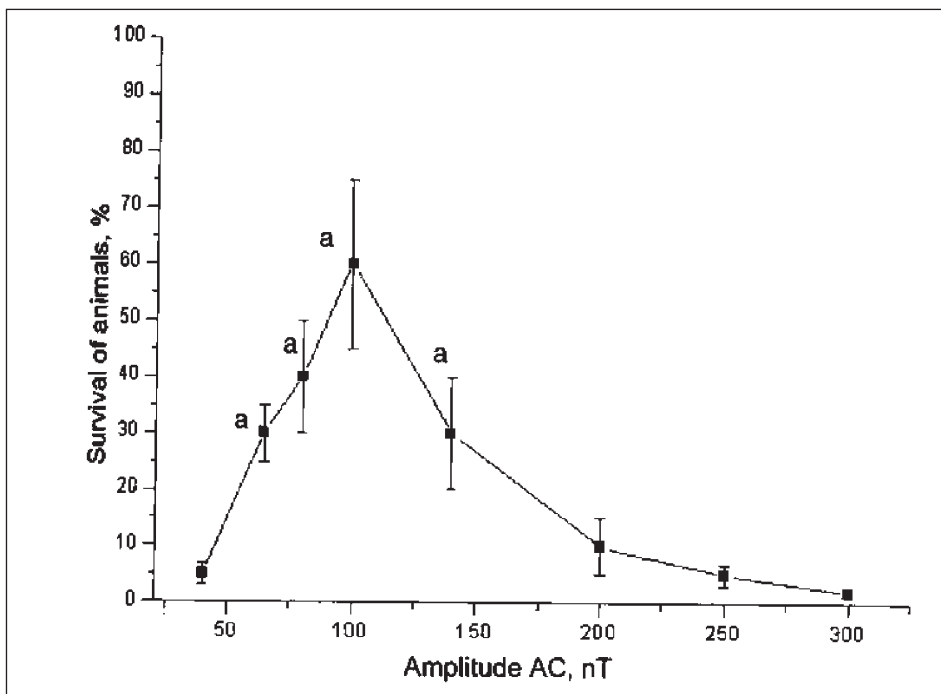

Fig. 5. Survival curve for mice infected with Ascites Ehrlich carcinoma³³, under ICR conditions corresponding to mean tuning (4.4 Hz) for aspartic acid and glutamic acid ions. In contrast to Fig. 2 where the frequency is varied, a resonance (or window) peak is observed as the AC magnetic field intensity is varied

fields”, but this is misleading, because the experimental requirements are more stringent than merely employing simultaneous static and time-varying fields. There is a critical constraint in choosing the specific combination of fields that are effective. In all the reports listed above the combined magnetic fields must be specifically chosen to fulfill the ICR signature, namely $\omega/B = q/m$.

Scientific consequences

Worth noting is that the EM hazards question is deeply entwined with the nature of the scientific method. Although the expression of scientific truth depends on a pair of complementary methods, the experimental and the theoretical, the former must be the ultimate decider. That which is first observed and subsequently confirmed in later trials is always considered truth. We are reminded of the great historical example of experimental observation triumphing over accepted dogma, attributed to Galileo, when he muttered *e pur si muove* (and yet it moves), in describing the motion of the earth around the sun.

Whenever experimental observations are very different from theoretical predictions, there is a need to reexamine the scientific basis underlying these predictions. In the present case the use of voltages and currents deduced from Faraday induction in passive

tissues are clearly not the reason for the biological effects that are so widely observed under weak, low frequency magnetic exposures. Indeed, predictions made using Faraday induction are diametrically at odds with what is observed in the laboratory.

The evidence points to the existence of an unknown biophysical mechanism, yet to be explained, that allows living systems to detect such exposures for purposes yet to be illuminated. It is emphasized that this is a matter that requires scientific investigation, not a blind reliance on the classical techniques that have been used to date in discussing the electromagnetic hazards question.

It is critical that epidemiologists, especially, understand the strength of this empirically based biological evidence. Future studies must avoid being designed around inapplicable assumptions, chiefly those that define a lower limit for biological interactions and those maintaining that more intensity is worse. Future studies must also incorporate some means of investigating the effects of exposures to combined static and time-varying magnetic fields.

It is indeed tragic that the level and quality of scientific investigation in assessing EM health effects has suffered because of an inappropriate unsophisticated approach, which in turn has led to poorly designed epidemiological studies and allocation of funding into useless research programs.

Conclusions

The question of biological plausibility of possible health hazards connected to power line magnetic fields has been dominated by arguments derived from Faraday induction, with little regard to very strong experimental evidence that is greatly at odds with the results of such calculations. It is important for the epidemiological community to understand that Faraday induction is not implicated in low level EM biological effects, and that the design of studies aimed at assessing EM health effects must be changed radically from the present approach.

It is a costly mistake in designing such studies to use assumptions based on the application of electrical engineering principles to simplistic biological models, where tissues are treated as electrically passive substances. The question of weak-field low-frequency magnetic interactions with living things is, at its heart, a *scientific* problem, with all the investigatory consequences that are attached to such problems.

The wealth of observations listed above make it difficult to avoid concluding that low level time-varying magnetic fields at power line frequencies are specifically interactive with biological systems, including humans. Further, the discovery by Zhadin's group and subsequent replications make it clear that ultra small AC magnetic intensities, down to 50 nT, falls into this interactive category.

The Zhadin results are closely dependent on a "windows" constraint, where interactions are only seen at certain limited ultra small magnetic intensities. Similar windows effects at higher intensities were observed more than 25 years ago, making it reasonable to question the validity of dose-response assumptions on the part of epidemiologists. Prior epidemiological studies not only have to be reexamined, but future studies must be designed in ways that do not assume a simple dose response is in effect for electromagnetic interactions with biological systems.

Finally, there is increasing interest in using ICR-like magnetic exposures for medical applications^{22,33,34,35}. In the long run, this may be the only way to prove the case for biolog-

ical plausibility among those who presently chose to deny that weak field low frequency magnetic fields do indeed interact with biological systems.

References

1. Hill AB. The environment and disease: association or causation? *Proc R Soc Med* 1965; 58: 293-300.
2. Liboff AR, Williams T Jr, Strong DM, *et al.* Time-varying magnetic fields: effect on DNA synthesis. *Science* 1984; 223: 818-20.
3. Takahashi K, Kaneko I, Date M, *et al.* Effect of pulsing electromagnetic fields on DNA synthesis in mammalian cells in culture. *Cellular and Molecular Life Sciences* 1986; 42: 185-6.
4. Blackman CF, Benane SG, Kinney LS, *et al.* Effects of ELF fields on calcium-ion efflux from brain tissue, in vitro. *Rad Res* 1982; 92: 510-20.
5. Dutta SK, Subramoniam A, Ghosh B, *et al.* Microwave radiation-induced calcium ion efflux from human neuroblastoma cells in culture. *Bioelectromagnetics* 1984; 5: 71-8.
6. Linet M, Hatch EE, Kleinerman RA, *et al.* Residential exposure to magnetic fields and acute lymphoblastic leukemia in children. *N Eng J Med* 1997; 337: 1-8.
7. Liboff AR. The ion cyclotron resonance hypothesis. In Barnes FS, Greenebaum B, eds. *Handbook of Biological Effects of Electromagnetic Fields: Bioengineering and Biophysical Aspects of Electromagnetic Fields*. 3rd Edition, 9. Boca Raton, FL: CRC Press, 2007, 261-9.
8. Weaver JC, Astumian RD. The response of living cells to very weak magnetic fields: the thermal noise limit. *Science* 1990; 247: 459-62.
9. Weaver JC, Vaughan TE, Martin GT. Biological effects due to weak electric and magnetic fields: the temperature variation threshold. *Biophys J* 1999; 76: 3026-30.
10. Adair RK. Constraints on biological effects of weak extremely-low-frequency electromagnetic fields. *Phys Rev A* 1991; 43: 1039-48.
11. Adair RK. Hypothetical biophysical mechanisms for the action of weak low frequency electromagnetic fields at the cellular level. *Radiation Protection Dosimetry* 1997; 72: 271-8.
12. Walker MM. On a wing and a vector: A model for magnetic navigation by homing pigeons. *J Theor Biol* 1998; 192: 341-9.
13. Martin H, Lindauer M. Orientierung in Erdmagnetfeld. *Fortchr Zool (Stuttg)* 1973; 27: 211-28.
14. Blakemore R. Magnetotactic bacteria. *Science* 1975; 190: 377-9.
15. Wiltschko R, Wiltschko W. *Magnetic orientation in animals*. Berlin: Springer-Verlag, 1995.
16. Kajiura SM, Holland KN. Electroreception in juvenile scalloped hammerhead and sandbar sharks. *Journal of Experimental Biology* 2002; 205: 3609-21.
17. Fitzsimmons RJ, Ryaby JT, Magee FP, *et al.* Combined magnetic fields increase insulin-like growth factor II in TE-85 in human osteosarcoma bone cell cultures. *Endocrinology* 1995; 136: 3100-6.
18. Jenrow KA, Smith CH, Liboff AR. Weak, extremely-low-frequency magnetic fields and regeneration in the planarian *Dugesia tigrina*. *Bioelectromagnetics* 1996; 17: 467-74.
19. Brain JD, Kavet RD, McCormick L, *et al.* Childhood leukemia: electric and magnetic fields as possible risk factors. *Environ Health Perspect* 2003; 111: 962-70.
20. Swanson J, Kheifets L. Biophysical mechanisms: A component in the weight of evidence for health effects of power-frequency electric and magnetic fields. *Rad Res* 2006; 165: 470-8.
21. Ahlbom A, Day N, Feychting M, *et al.* A pooled analysis of magnetic fields and childhood leukemia. *British J Cancer* 2000; 83: 692-8.
22. Diebert MC, McLeod BR, Smith SD, *et al.* Ion resonance magnetic stimulation of fracture healing in rabbits with fibular osteotomies. *J of Orthopedic Res* 1994; 12: 878-85.
23. Lednev VV. Possible mechanism for the influence of weak magnetic fields on biological systems, *Bioelectromagnetics* 1991; 12: 71-5.
24. Shuvolova LA, Ostrovskaja MV, Sosunov EA, *et al.* Effect of weak magnetic field in the parametric resonance mode on the rate of calmodulin-dependent phosphorylation of myosin in the solution. *Doklady Akademii Nauk SSSR (Reports of the Academy of Science of the USSR)* 1991; 317: 227-30 (in Russian).
25. Blanchard JP, Blackman CF. Clarification and amplification of an ion parametric resonance model for magnetic field interactions with biological systems. *Bioelectromagnetics* 1994; 15: 217-38.

26. Berden M, Zrimec A, Jerman I. New biological detection system for weak ELF magnetic fields and testing of the Parametric Resonance Model (Lednev 1991). *Electromag Biol and Med* 2001; 20: 27-41.
27. Zhadin MN, Novikov VV, Barnes FS, *et al.* Combined action of static and alternating magnetic fields on ionic current in aqueous glutamic acid solution. *Bioelectromagnetics* 1998; 19: 41-5.
28. Pazur A. Characterization of weak magnetic field effects in an aqueous glutamic acid solution by nonlinear dielectric spectroscopy and voltammetry. *Biomagn Res Technol* 2004; 2: 8-19.
29. Comisso N, Del Giudice E, De Ninno A, *et al.* Dynamics of the ion cyclotron resonance effect on amino acids adsorbed at interfaces. *Bioelectromagnetics* 2006; 27: 16-25.
30. Giuliani L, Grimaldi S, Lisi A, *et al.* Action of combined magnetic fields on aqueous solution of glutamic acid: The further development of investigations. *Biomagn Res Technol* 2008; 6: 1-7.
31. Alberto D, Busso L, Crott G, *et al.* Effects of static and low-frequency alternating magnetic fields on the ionic electrolytic currents glutamic acid aqueous solutions. *Electromagn Biol Med* 2008; 27: 25-39.
32. Novikov VV, Fesenko EE. Hydrolysis of some peptides and proteins in weak combined static and low-frequency alternating magnetic fields. *Biofizica* 2001; 46: 235-41.
33. Novikov VV, Novikov GV, Fesenko EE. Effect of weak combined static and extremely low-frequency alternating magnetic fields on tumor growth in mice inoculated with the Ehrlich Ascites carcinoma. *Bioelectromagnetics* 2009; 30: 343-51.
34. Bobkova NV, Novikov VV, Medvinskaya NI, *et al.* Reduction in the β -amyloid level in the brain under the action of weak combined fields in a model of sporadic Alzheimer's disease. *Biophysics* 2005; 50: S5-S7.
35. Gaetani R, Ledda M, Barile L, *et al.* Differentiation of human adult cardiac stem cells exposed to extremely low-frequency electromagnetic fields. *Cardiovas Res* 2009; 82: 411-20.

Oxidative stress-induced biological damage by low-level EMFs: mechanism of free radical pair electron spin-polarization and biochemical amplification

Christos D. Georgiou

Professor of Biochemistry, Department of Biology, University of Patras, Greece

Abstract

Low-level electromagnetic field (EMF) interactions with organisms are based on the physics and chemistry of electron spin shifting of the transient radical pair and triplet state molecules formed by homolytic bond splitting within cells, and on the biochemistry of non-linear dynamic processes as they are related to the biological amplification of the EMF-induced initial effect. These processes, alone or in combination, could induce biochemical signal transduction interaction pathways by which weak EMFs can cause organism dysfunction and disease. EMF effects originate for the most part in the geminate recombination processes where free radical pairs are created. No recombination permitting electron spin shifting can result from local EMF effects on unpaired electrons if both free radicals are tethered by interactions with macromolecules or supramolecular biological structures at the right separation distance. Any field-induced change in the concentration of the free radicals that survive recombination may alter the rates of their subsequent reactions. These effects can become quite pronounced and harmful for man by existing dynamic, non-linear biological mechanisms that amplify the biochemical effects of small changes in radical concentrations, especially those of oxygen-centered free radicals responsible for the creation of genotoxic oxidative stress. This synergistic mechanism is supported by experimental evidence from vast EMF exposure studies on various biological systems (human/animal cell cultures, whole animals, and even plants) covering static magnetic, extra low frequency and radiofrequency fields (SMF, ELF and RF, respectively); SMF (as low as 0.05 W/m²), ELF 3-195 Hz (as low as 10 μT) and RF 400 MHz-300 GHz (as low as 0.2 W/m² and SAR 0.016 W/kg). In brief, EMF exposure has been shown to cause high oxidative stress-induced biological damage, manifested by a substantial increase of peroxidized lipids, oxidized proteins and fragmented/nicked DNA. Substantial decrease has been also documented in the antioxidant defense mechanisms, i.e., in the activity of crucial antioxidant enzymes and in the concentration of endogenous antioxidants. Exogenous antioxidants and inhibitors of certain ROS/RNS-producing enzymes reversed all these effects, which is another strong evidence for the causative relation between oxidative stress and EMF exposure. EMF-induced oxidative stress

Address: Christos D. Georgiou, Department of Biology, University of Patras, 26100 Patras, Greece
Tel. +3061-997227 - Fax +3061-997840 - E-mail: c.georgiou@upatras.gr

has been also shown *in vitro* by the increase of reactive oxygen/nitrogen species (ROS/RNS) indirectly assessed by non-specific assays. New quantitative and specific *in vivo* ROS assays are proposed for the conclusive verification of the oxidative stress mechanism, as well as specific quantitative indicators of biological damage that can be used for the reassessment of the EMF exposure limits. The present report offers a combined free radical pair/oxidative stress mechanism in order to explain how EMFs can cause disease in man. Moreover, it offers a scientifically solid background mechanism for the experimental design of epidemiological studies, while it extends its conclusions to the redefinition of safer EMF exposure limits for the public.

Key words: disease, EMF, oxidative stress, free radicals, radical pair mechanism

“Are there biological effects? The engineers and the physicists say absolutely not. Their view in general of what living systems consist of, is that the cells are little plastic bags filled with minestrone soup. And you can then, with that sort of a concept, calculate the field strength and the frequencies you would need to produce an effect on the minestrone soup. And this is exactly the concept that was employed after it became apparent that radar systems could heat up the human body. The physicists that were involved in answering the question: Are there effects? And at what level do they occur? And what would be a safe level? Basically, they followed a basic precept, which was to consider a spherical cow; a circular oval object filled with conducting solution and composed of a skin that is transparent to the radio frequency waves that microwave generators produce. And on that basis, they asked: How much does it take to heat this up? Where does the cow’s temperature start to rise? And that number was calculated and confirmed in actual procedures in the lab using the spherical cow concept. They said, “OK, that’s the number at which you are going to start heating people. Let’s say that’s not such a good idea and we’ll set a level ten times lower as the safe level”...“I have no doubt in my mind that at the present time the greatest polluting element in the earth’s environment is the proliferation of electromagnetic fields.”

Robert O. Becker, M.D., author of the books *The Body Electric* and *Cross Currents: The Perils of Electropollution* (interview: www.emrnetwork.org/pdfs/becker.pdf, accessed on June 2, 2010)

Introduction

Several non-thermal mechanisms have been proposed to explain the effect of low level EMFs (ELFs and RFs; extremely low frequency and radiofrequency fields, respectively) and static magnetic fields (SMFs) on biological systems and man. They involve e.g. induction of electric currents by acceleration of ions, resonant interactions involving driving vibrations or orbital transitions in biomolecules¹, direct interactions of EMFs with moving electrons within DNA², and forced vibrations of free ions of the cellular surface that distort the gating of electro-sensitive channels on the plasma membrane. Another proposed mechanism of action is that EMFs increase free radical activity. This mechanism is supported by experimental evidence and is based on sound physics and chemistry principles³⁻⁷.

The free radical mechanism presumes that EMFs must interact with the biological system via their electric and/or magnetic component. External electric fields, especially the low intensity ones, are strongly attenuated by polar organic molecules such as those composing the human body, thus, they become insignificant compared to external magnetic fields. On the other hand, since the magnetic field is essentially unchanged it

is a more likely source of biological effects. This has been supported by epidemiological studies with magnetic fields stronger than about $0.4 \mu\text{T}$ (superimposed on the geomagnetic field)⁸, and by direct biological and biochemical evidence from studies e.g. with fields $\sim 100 \mu\text{T}$ on murine fibroblast-derived 3T3-L1 preadipocytes and on rat brain cells (causing free radical induced increase of oxidative stress and significant DNA fragmentation, respectively)^{9,10}.

The effects of low-level electromagnetic radiation (ELF and RF) on a biological system can be explained by the free radical pair mechanism. This involves the recombination of short-lived species, such as reactive free radicals, whose importance in biology and disease is well established. It has been known that magnetic fields influence a certain class of chemical reactions that involve short-lived free radical intermediates through kinetic processes in an indirect manner⁴. Such chemical reactions occur widely within the body, and they maybe influenced by the magnetic field component of EMFs, which, unlike the electric field component, is not greatly attenuated inside the body and can affect the biochemistry within it.

In brief, the free radical pair mechanism requires the creation of free radicals in pairs with correlated electron spins^{3,6,11-14}. The thermal and enzyme reactions that produce free radicals in biological systems normally involve singlet states of the precursor molecules. The electrons in the chemical bond that breaks homolytically to form free radicals have antiparallel spins, as do the resulting free radicals themselves. Since the electron spins must be antiparallel to form a bond, the free radicals might be expected to recombine immediately. However, the energy released by the reaction causes them to separate rapidly so that relatively little instantaneous reaction occurs. Subsequently, the magnetic interactions of the electron spins with the nuclei of nearby hydrogen and nitrogen atoms modify the spin state of the radical pair, giving to it partially a triplet character. Therefore, EMFs stabilize free radicals in such a way as to permit their dispersion rather than their return to the ground state¹⁵. The effect of the field is indirect, and depends on the mixing of the singlet state and the existing three triplet sub-levels of the radical pair, two of whose energies are field-dependent. The prolonged lifetime of free radicals will increase the probability of radical-mediated biological damage, if the radicals involved are oxygen free radicals (such as superoxide and hydroxyl radicals) responsible for the development of oxidative stress¹⁶.

There is ample evidence that EMFs in their entire frequency spectrum induce increase of oxidative stress and oxygen free radicals in many experimental systems (including plants) and in man. Therefore, the free radical pair mechanism by working synergistically with the biological mechanism of oxidative stress provides the required coupling of EMFs to the chemistry of biological systems. Moreover, this combined mechanism overcomes the thermodynamic restrictions (imposed by EMFs non-ionizing energy), which say that the interaction energy of any electric or magnetic moment induced or possessed by an electromagnetic source (EMFs, geomagnetism) is negligible compared to the random thermal energy any biological system possesses at room temperature. This is the argument mainly physicists use to support their basic thesis that EMF effects on biological systems cannot occur at low field strengths, implying e.g. that they cannot affect the equilibrium in a chemical or biochemical system. However, this ignores the facts that biochemical and biological processes (a) rarely run at equilibrium, (b) are controlled by the kinetics of the chemical processes occurring within them⁵, and (c) they can result in amplification of the primary effect because they are non-linear and dynamic in nature, rendering these energetic arguments irrelevant.

The present report offers a new mechanism, which is a synthesis of the free radical pair and oxidative stress mechanisms, in order to explain how EMFs can cause disease in man. This mechanism is based on solid principles of physics and on ample experimental evidence, and thus it can be central for the experimental design of epidemiological studies as well. Moreover, this report extends its conclusions towards the introduction of additional new criteria for the redefinition of safer exposure limits for the public.

Free radical reactions

In order to understand the effect of a magnetic field on a radical reaction, its association with certain fundamental aspects of chemistry needs to be explored. These aspects concern the nature of the chemical bond formed by the sharing of two electrons between atoms or groups of atoms, and what happens after it is broken in the absence and presence of an external magnetic field. Electrons possess spin angular momentum, known as spin, a vector property normally represented by an arrow in magnitude and direction. When two of them interact, the spin of one can be oriented parallel or antiparallel to that of the other. In order for a bond to form, the two electrons must have opposite spins, the angular momenta of which then cancel so that the total angular momentum of a molecule containing paired electrons is zero. The resulting molecule is said to exist in a singlet electronic state, which is the normal lowest energy state of the vast majority of biological molecules. Molecules can also exist in higher energy states that can be singlet (S) or triplet (T) electronic state (also denoted by a superscript ‘1’ or ‘3’, respectively). In the latter state (T), the two electrons with parallel spins do not form a bond but inhabit different orbitals. In fig. 1 you can see a pictorial description of spin angular momentum of S and T states (fig. 1A) and the conversion of S to T state under the influence of local (different for each electron) magnetic field (figs. 1B, 1C).

If in a molecule being in its ground state a bond is broken in a homolytic biochemical reaction, one of the two electrons of the bond ends up on each of the two free radicals formed (denoted by a superscript dot to represent the single unpaired electron). As it is known, small free radicals, especially oxygen free radicals such as superoxide radical ($O_2^{\cdot-}$) and hydroxyl radicals (OH^{\cdot}), are characterized by extreme reactivity, and their normal reaction fate is to abstract atoms (e.g. hydrogen) from molecules, and to add to double bonds and to aromatic rings. They may also dissociate to expel a stable molecule such as carbon dioxide¹⁶. The common feature of all these processes is the production of secondary free radicals. Free radicals persist separated until they encounter other free radicals during diffusion to form another chemical bond, an overall process that typically takes place at the millisecond scale after radical formation (in normal viscosity solutions).

In order to appreciate the EMF effect, the chemical implications involved can be illustrated by the following photochemical example⁵ that proceeds via an excited triplet state and is relevant in a broad sense, for example, to the photosynthetic process.

The reaction of benzaldehyde (PhCHO, Ph = C_6H_5 , in tetrachloromethane solvent) is considered, under UV light exposure. Following UV absorption, the ground state singlet molecule is excited to an excited singlet electronic state, which then changes rapidly into an excited triplet state by intersystem crossing (ISC), that is, an isoenergetic non-irradiative transition between two electronic states having different spin multiplicities:

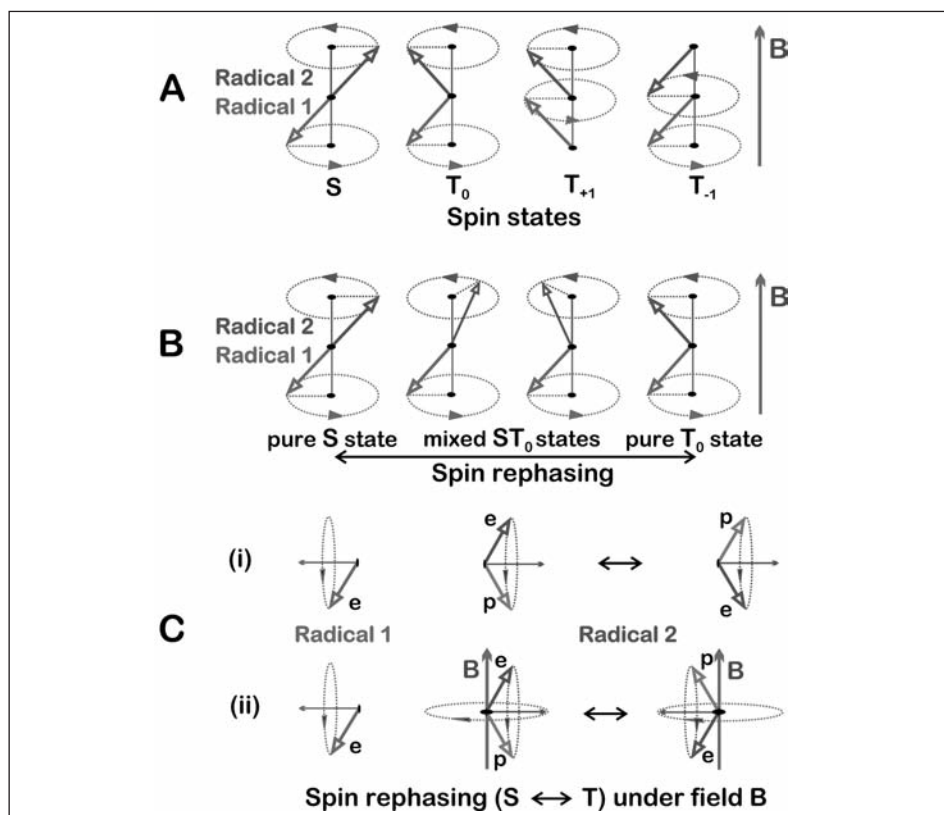

Fig. 1. A. Vector representation of the four electron spin states of the radical pair being in a magnetic field of magnitude B . The two arrows represent the intrinsic spin angular momenta of the two separate radicals. Spin state $S \leftrightarrow T_0$ interconversion can occur by a simple change in the phase relationship of the two spins (see B). However, to convert electron spin S state to either of the other triplet states requires one spin to flip from one of its possible orientations to the other. Spin angular momenta can be resolved into three orthogonal components (not shown) and, as the diagram shows, the resultant component in the direction of the field is zero in the S and T_0 states, and non-zero for the others. T_0 differs from S in having a non-zero resultant perpendicular to the field in a reference frame rotating at the precessing frequency. B. The electrons precess about the magnetic field direction at different rates depending on the differing local magnetic fields at the electrons in the two radicals. This inevitably will cause an initially S state to transform into a T_0 . Between the two extremes, the radical pair shows mixed S and T_0 character. The diagram is drawn in a reference frame rotating at the precession rate of the electron of radical 1, and the electron of radical 2 is seen to move relative to it. C. Spin mixing in a radical pair concerns the relative orientations of two electron spins on separate radicals, which do not interact while the mixing occurs. That is, the one does not create a magnetic field at the other. This implies that in a radical pair, initially being in the singlet state, the evolution of the spin state of one radical is considered in relation to the other's spin, whose direction is kept constant. (i) In zero field in a radical containing a single proton, the electron (e) and the proton (p) magnetic moments couple to give a resultant around which the electron and proton spins separately precess. This cannot change the direction of the electron spin completely with respect to the direction of the other. (ii) Application of a weak external field, however, establishes a local field in the radical with the coupled electron and proton magnetic moments, absent in the first case. While the electron and the proton continue to precess about their resultant, this in turn precesses about the field direction, and now the electron spin can become inverted with respect to the direction of the applied field, and to the second electron (of radical 1). Reference to (B), then, shows that an $S \leftrightarrow T$ conversion has been accomplished (adopted from elsewhere⁵)



The triplet state then abstracts a hydrogen atom from another molecule of benzaldehyde to form a geminate (i.e. born together) pair of free radicals, which may then combine to form a product known as the geminate cage product:



However, not all the free radicals produced react with their immediate partner free radicals because some diffuse from their initial region of formation into the surrounding medium, where they may undergo further reactions that form different products known as escape products. For example,



Various free radical reactions, therefore, continue to occur until two free radicals happen to diffuse together to form one of several possible radical combination products (additional escape products) until all free radicals are removed from the system.

Actually, an external EMF changes the probability by which the geminate free radicals recombine to form the cage product. In other words, the field alters the radical concentration and the overall escape product-to-cage product ratio^{5,15}. This experimentally established phenomenon is explained in more detail below.

The reaction mechanisms describing the spin involvement when a bond is broken in a homolytic process is based on the rule that the direction of the electron spin orientation is conserved after bond splitting. That is, the singlet molecule splits to a pair of free radicals (R_1 , R_2) the electron spins of which are antiparallel to each other at the time of formation. Both free radicals retain the same total angular momentum as the predecessor singlet molecule, and the so formed geminate radical is also in a singlet electronic state:

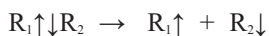

In the photochemical example, in particular, the geminate free radicals are formed from the reaction of the excited to the triplet state molecule. So, their electron spins would be parallel when they are formed. However, the free radicals that exist in organisms are created from molecules in singlet states that lead to singlet radical pairs. These free radicals can encounter a range of actual situations within cells. For instance, the free radicals might be produced in isotropic solution cytoplasmic regions and diffuse freely in relation to each other, and one radical may be immobilized by attachment to an enzyme surface with the partner radical able to diffuse around it (or both free radicals may be so attached), or localized within a membrane, at the time of their creation.

The fact that chemical bonds are formed between free radicals with electrons of opposite spin does not mean that the pair of singlet-correlated free radicals produced by homolytic bond splitting would quickly react to form the cage product. Some free radicals do not immediately recombine and because of the released energy they diffuse through their immediate environment. In other words, this is possible because biochemical reactions are not instantaneous but depend on overcoming a small activation free

energy, or satisfying steric requirements (i.e. a reaction may occur only if the free radicals approach each other in a certain direction). This is crucial for the effect of an EMF to manifest itself on a radical reaction, because it also depends on this rapid initial separation of the formed free radicals.

In terms of EMFs effect importance, the reactions between free radicals are differentiated by two types of reaction processes¹⁷: (1) Geminate processes, including those reactions that occur extremely rapidly as a result of encounter between pairs of free radicals created geminately with antiparallel spins from singlet precursors – they are said to involve the encounter of geminate pairs; (2) Diffusion-controlled processes, including those reactions (with large rate constants $\sim 10^9 \text{ dm}^3 \text{ mol}^{-1} \text{ s}^{-1}$ in water) which occur on a longer timescale between two separately created free radicals wandering together and reacting one with the other – they are said to involve the encounter of freely diffusing pairs (F-pairs). Geminate pairs and F-pairs are strictly differentiated by the spin correlation existing at the instant of formation in the first case, and being established at the encounter in the second.

The probability of re-encounter of two geminate free radicals created together at the time origin falls rapidly with time, reaching about 10% of its initial value within about 100 ps in solutions of normal viscosity^{18,19}. However, field effects arise only 10-100 ns after radical creation.⁵ Therefore, if field effects are going to arise it is necessary to restrain the short-term diffusion of the free radicals formed in biological systems (e.g. by attachment on membrane, protein, enzyme surfaces, etc.), which has been shown experimentally with DNA and proteins (see section “the free radical pair mechanism”). This furthermore increases the re-encounter probability and increases the overall proportion of the initial radical pairs affected. This is true for F-pairs too, in which field effects also occur, but the overall effects on the chemistry involved tend to be smaller⁵.

If we consider that the half-life of superoxide radical is 1-100 ns²⁰, reaching up to 1 μs under certain conditions, it can be expected that this radical will experience external EMF effect as well. And this is very important for explaining the biological effects of EMFs, since superoxide radical is the central oxygen free radical responsible for the creation of high oxidative stress in organisms,¹⁶ as it will be explained in section 7 in more detail.

EMF effects originate from electron spin polarization

The effect of magnetic fields on free radical reactions primarily originates from the fact that the electron has a magnetic moment because it is electrically charged and has spin angular momentum. Therefore, the electron spin is the electron’s electromagnetic field angular momentum, making the electron nature’s smallest magnet. The electron spin magnetic moment is important in the interaction of atoms with external magnetic fields, in addition to the interaction between the magnetic field and the magnetic dipole moment associated with the electron’s orbital angular momentum (due to its rotation around the nucleus). Thus, free radical-involving chemical reactions are affected by the applied EMF because of its interaction with the magnetic moment of the electron.

The magnetic moment (its z-component) value associated with the electron spin has a magnitude equal to $\pm \frac{1}{2} g \mu_B$, where $\frac{1}{2}$ is the spin quantum number of the electron, g is an empirically defined constant (called gyromagnetic ratio, characteristic of the electron), and μ_B is the fundamental unit of quantum magnetism, the Bohr magneton.

The property is conveniently demonstrated in electron spin resonance (ESR) experiments where the free radicals are introduced into an applied field of magnitude B . ESR spectroscopy is based on measuring transitions between spin states of unpaired electrons by varying the applied magnetic field while irradiating the sample at microwave frequencies. However, in the absence of a field the free radicals that contain electrons of opposite spin are of equal energy, some electrons (very slightly greater than half) now align with the applied field and the others against it, and their energies differ. When the magnetic field reaches the point at which the energy difference between the two allowed orientations of the electron spin is equal to the microwave quantum ($h\nu$), a spectroscopically detectable resonance occurs at the resonant microwave frequency, ν , according to the relation $h\nu = g\mu_B B$, where h is Planck's constant; the experiment is usually performed by keeping the frequency constant and sweeping the field until a resonant absorption of energy is observed (fig. 2). Atoms and molecules with unpaired electrons (i.e. free radicals) are identified by their characteristic resonance spectra and by the so-called g value. The g value of a free electron is 2.0023, and thus, important biological radical species such as superoxide radical have a signature near the $g = 2$ region of the spectrum.

A free radical, however, does not exhibit a single field at which energy is absorbed (fig. 2). For example, the hydrogen atom (with a single electron) exhibits two resonance lines showing a characteristic splitting between them termed the hyperfine coupling constant, A_H . The methyl free radical, CH_3^\cdot (Me) exhibits a quartet spectrum with a different characteristic splitting with hyperfine coupling constant A_{Me} . For carbon-

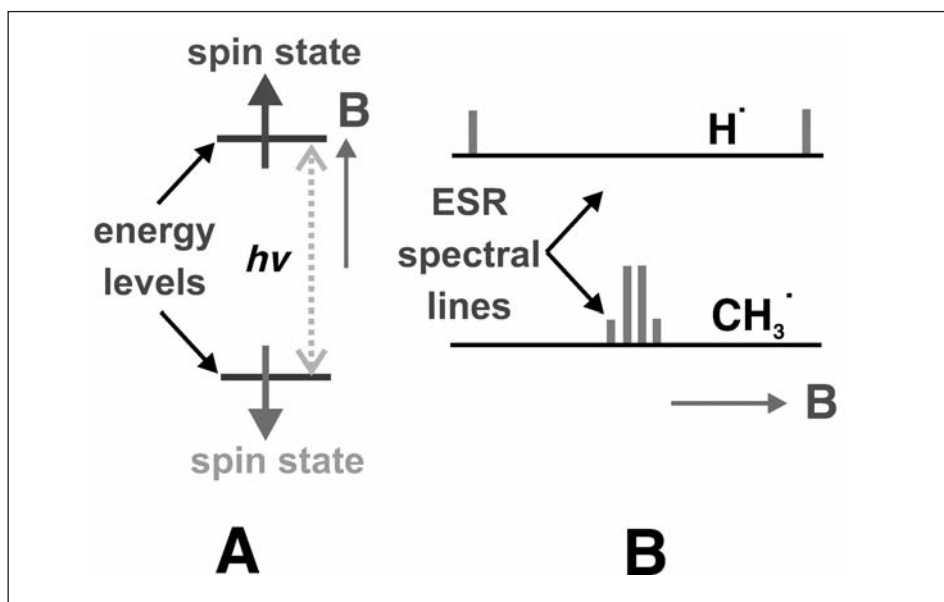

Fig. 2. A. The two spin states (antiparallel) of the electron acquire different energies in the presence of an applied field. By applying radiation at the correct frequency a spectroscopic transition can be induced between them, known as electron spin resonance (ESR) process. The magnetic moments of the electrons lie antiparallel to their spin angular momenta. **B.** Typical ESR spectra of the hydrogen atom and the methyl radical, exhibiting hyperfine structure due to coupling to the magnetic protons (adopted from elsewhere⁵)

centered free radicals, A varies from 0.01 to 3 mT, that is, it takes values even below the mean geomagnetic field (50 μ T). A is also, and more often, expressed in terms of equivalent frequency, with 1 mT corresponding to a frequency of 28.6 MHz.

The ESR-hyperfine coupling structure derives from the fact that protons are also spin $\frac{1}{2}$ species, and thus magnetic, as electrons also are. Specifically, it is due to spin coupling between protons and the singlet electron in the atom of the free radical, and is independent of the size of the applied field, B . This independence is important in understanding the effects of magnetic fields on radical reactions because it introduces the concept of individual local magnetic fields that electrons experience when exposed to external fields (fig. 1C), with both the magnetic parameters g and A signifying this. That is, the actual magnetic field experienced by the electron in the free radical is not the same with the applied field. Most importantly, the actual fields affect free radical-associated chemical reactions. The reason is that the actual field experienced by the electron of each of the two homolytically created free radicals is not the same to each other, and is not the same with the external field.

In understanding EMF effect, it should be also kept in mind that as the free radicals are created as a singlet-correlated pair in a homolytic reaction, they do not persist in this state. That is, the singlet state evolves in time into three triplet states, resulting in the so-called “ST mixing” (see vector model of this spin mixing in fig. 1B); S designates the singlet state of the radical pair, and T its triplet state. Spin evolution takes place because the electron on each radical experiences – in addition to the applied field – the local magnetic fields from nearby magnetic protons as modified by the applied field. In real systems spin state evolution occurs under the influence of many hyperfine couplings.

Radical pairs in S states can react if they encounter each other but not those in T states. Three quarters (i.e. the three T states) of the two electron spin states of the initial radical pairs are inhibited from reaction once this transformation has occurred⁵. The S–T change takes about 10-100 ns (as stated in section “free radical reactions”) when organic free radicals are involved, which is the period to allow field effects to develop, and free radicals, which then re-encounter, simply drift apart again. Because of the continuous nature of the ST mixing process, 10-100 ns later the radical pair could re-attain the singlet state but because the free radicals have become well separated the probability of re-encountering a second time and reacting is nearly zero.

Proteins containing heme as prosthetic group exhibit hyperfine coupling as well²¹. In particular, studies have shown that haemin exhibits a hyperfine structure; due to its iron ion existence in two angular momentum states ($S = 5/2$ and $1/2$). The applied magnetic field increases the occupation of the low-spin state²². Heme proteins are important biological molecules that catalyze radical reactions, and thus they can induce proton spin coupling dependent local field effects on the involved intermediate free radical substrates. Heme proteins are e.g. the important antioxidant enzymes catalases and peroxidases, the oxygen transporters hemoglobin and myoglobin, and all mitochondrial respiratory chain (and photosynthetic electron chain) cytochromes. Mitochondrial cytochromes include those responsible for formation of superoxide radical such as complex I and III (cytochrome bc_1 complex), functioning in conjunction with intermediately formed free radicals of FAD and coenzyme Q, respectively^{16, 23}.

In conclusion, external EMFs do not change the nature of the free radical reaction product. They only alter the ratio of free radicals that react in the geminate and escape processes, with consequent changes in the ratios of the amounts of cage and escape products. That is, a field may increase the number of escaping free radicals as it is sometimes

observed when free radicals are formed by a homolytic splitting of a singlet state molecule at very low field strengths, including those of the order of the geomagnetic field. Under these conditions, more free radicals survive the geminate period of reaction than at either higher or zero field⁵. This provides a possible mechanism for a field to affect biological processes, given the experimental observation that the increase of oxygen free radicals in organisms is harmful because it imposes to them increased oxidative stress. Although the formation of specific oxygen free radicals under EMF (ELF and RF) exposure has not yet been shown directly, their indirect presence (manifested as oxidative effects on crucial biological molecules such as lipids, DNA, and on the antioxidant defense) has been already documented experimentally (as shown in section “EMF-induced oxidative stress via the radical pair mechanism”).

The free radical pair mechanism

EMFs have measurable effects on the kinetics and yield of chemical reactions that use geminate radical pairs through their effect on the spin precession rates of unpaired electrons and consequent effects on the lifetime of radicals²⁴⁻²⁷. As stated previously, all free radical producing biological reactions yield their free radical products in singlet state pairs. Under the action of a local field, a free radical pair in S state at the instant of formation subsequently changes into T. This affects the probability of the reaction governed by the strict combination between free radicals of the S state only. The first stage lies in the spin-mixing process under the influence of the hyperfine interactions in the free radicals. Then, it should be taken into account the probability that the free radicals re-encounter when the pair is in a specific spin state, and the magnitude of the field effect depends intimately on the interplay between the rate processes of spin-mixing (fig. 1B) and molecular diffusion. It follows, that the lifetime of the free radical pair has a crucial effect on the magnitude of the field effect observed, particularly in the low-field region.

Spin state S–T conversion for organic free radicals lasts at least a few nanoseconds, which means that biological processes will be affected by small ELF fields if they involve long-lived radical pairs in which the free radicals remain in close proximity for about 100-1000 ns. Such time durations can exist inside cells since free radicals (such as the oxygen centered superoxide radical ion) may be formed in regions of high viscosity (e.g. in mitochondrial membrane bilayers) or of restricted motion (e.g. in or on cell walls, on enzymes, etc.). If two radicals are formed in a restricted biological site such as a lipid bilayer or a micelle, the possible spin evolution of this pair can follow two major processes: (1) reaction of the paired radicals with each other, and (2) their separation followed by reaction with other molecules present in the system. In many cases, this radical pair will have a triplet configuration (i.e., having parallel spins).

This configuration may result e.g. from the simple fact that random encounters lead to a triplet configuration 75% of the time and the rest by other means (e.g. via a photo-induced process)²⁸ as follows. Pairs of radicals in a triplet configuration cannot react with each other unless spin evolution (intersystem crossing; ISC) leads to a singlet state, where radical spins are adequate for product formation. That is, if radicals are generated in the triplet state they must move to the singlet state (spins antiparallel) before reacting. This interchange can occur as a result of local magnetic fields from nearby magnetic nuclei through the hyperfine interaction. Moderate EMFs can influence the kinetics of intersystem crossing (k_{isc}) through Zeeman-splitting of the triplet sub-levels and, as a

result, modify the partition between the radicals that react with their partner (within the radical pair) and those that separate and become available for alternative free-radical reactions. They actually remove the degeneracies of the triplet state sub-levels and can cause separation between triplet states greater than the hyperfine interaction, effectively preventing interchange of electrons and stopping up to two thirds of radical pairs reacting²⁶. These radicals that undergo escape or separation processes are those most likely to participate in reactions of relevance in the biological and health sciences (fig. 3). The fact that EMFs can modify free radical reactions implies that they should be also able to modify cellular processes¹⁵.

The individual free radical events (the lifetime of radical-radical encounters) take place in the ns to μ s time scale. Since at 60 Hz each field cycle takes 16.67 ms and a 900 MHz (GSM cell phone carrier frequency) takes 1.1 ns, one can anticipate that the radicals will “sense” SMF (static magnetic field)/ELF/RF during the short lifetime of the radical-radical encounters (radicals may have very long lifetimes but it is the lifetime of their encounters that is important for EMF interaction purposes). For example, the influence of 60-Hz magnetic fields on free radical reactions (using benzophenone as the source of pair radicals; ketyl and cyclohexadienyl radicals) can be quantitatively predicted from the knowledge of the effect of SMF on free radical behavior. Studies of radical reactions in micellar systems show that the behavior under a 60-Hz field is identical to that under a SMF at any given point in time. The following expression provides an empirical experimental data fit: % Escape = $30.4 + 28.4 (1 - e^{-0.00337 H})$, with 30.4 being the % escape at zero field and $H = 2^{1/2} H_{rms} |\sin \theta|$ (where H_{rms} the average 60 Hz-field magnitude, θ the field phase angle at the time radical generation takes place, and the use of the absolute value reflecting that radical behavior is independent of field polarity)^{15,29}.

Free radical confinement e.g. by proteins and DNA has been already shown experimentally with the benzophenone-derived pair radicals³⁰ mentioned above. Radical pairs derived by hydrogen abstraction of triplet benzophenone and some of its derivatives from bovine serum albumin, human serum albumin and calf thymus DNA are confined by proteins and DNA for a sufficiently long period of time for spin evolution to be

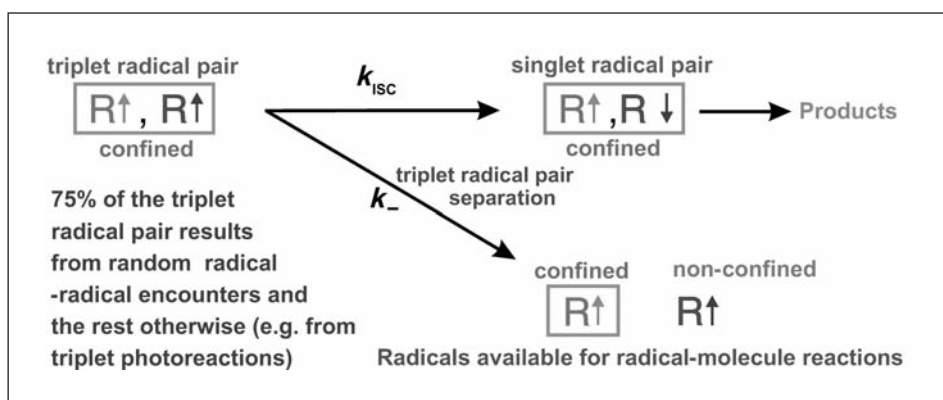

Fig. 3. A. EMF effects on paired spin radicals resulting from homolytic splitting. Under most circumstances, EMF will reduce intersystem crossing (k_{isc}), and, as a result, will increase the availability and steady-state concentration of free radicals (R). Boxes designate free radical confinement condition (adopted from elsewhere¹⁵)

affected by external EMFs. In proteins the radical pair retains its geminate character (i.e. remains confined) for about 0.5-1 μ s. For DNA, the magnetic field alters the radical reactivity only over times ≤ 50 ns, suggesting poor confinement, with electron transfer interactions maybe playing a rôle; timescale for these effects can be increased by promoting coulombic (positive-negative) attraction between DNA and the radical precursor³⁰.

Spin state S-T interconversion can be also affected by random, incoherent, "relaxation" processes (well known in isolated free radicals in ESR spectroscopy) from excited or otherwise perturbed spin states towards or into thermal equilibrium. Crucial free radicals in organisms for the development of oxidative stress, such as oxygen free radicals, although may have very short relaxation times not favoring direct EMF-effects, they become insignificant. The reason being that oxygen free radicals are very reactive, resulting in the formation of secondary carbon-centered free radicals within the geminate pair, with conservation of spin orientation. All these are more probable sources of field effects. Relaxation processes can cause either random spin flips (the so called spin-lattice relaxation process occurring with a characteristic time T_1) or change the relative phase of the components of the spins of the two electrons in the direction perpendicular to the field (with a characteristic time T_2). The former originates in fluctuating local fields (including RF-EMF's) inside the sample, and causes S and T_0 to $T_{\pm 1}$ interconversion, while the latter depends on static components of the local fields, and causes S to T_0 conversions. In normal solutions at room temperature, T_1 and T_2 are equal and of the order of a microsecond, and relaxation can usually be neglected. If, however, the free radical is restricted e.g. on a protein or in a biological membrane, T_2 can shorten considerably as a result of an increase in the rotational correlation time.

The spin-interconversion processes and rapid free radical reactions already described occur on a timescale of a few tens of ns. This means that free radical pairs see as static any field oscillating at a frequency of less than about 0.01 GHz (10^7 Hz). In particular, power mains (line) frequencies of 50-60 Hz are static on this timescale, as are the lower frequencies whose resonant effects in biological systems have been reported. Thus, magnetic field effects on radical recombination reactions remain independent of the frequency of the radiation until resonant effects are observed in the radio frequency (RF) region.^{5,31} The effects of resonant radiofrequency and microwave fields (EMF-RF) on chemical and biochemical systems observed in the presence of static fields of various magnitudes are well established. They depend upon exciting spectroscopic transitions between the singlet and triplet states of radical pairs and are fully consistent with the free radical pair mechanism^{4,17}.

The free radical pair mechanism can explain free radical-induced damage in biological systems exposed to SMF, ELF and microwave frequencies. For example, tumor-promoting phorbol 12-myristate 13-acetate (PMA) - induced oxidative burst (producing reactive oxygen free radicals) in rat peritoneal neutrophils was further increased by exposure to 60Hz. This was attributed to the increase of the probability that a free radical pair will remain in the triplet configuration (by decreasing intersystem crossing), thus increasing the probability that two free radicals will escape without termination. Because fewer terminations of radical pairs occur, the overall concentration of radicals increases, and a potentiation of free-radical induced effects in biological systems may be expected, with both time varying and static magnetic fields participating in such interactions³². In relation to RF effects, in Fe^{2+} -treated rat lymphocytes exposed to continuous 930 MHz (carrier of cellular phone emitted signals) an increase of reactive oxygen species (ROS)

was documented³³. This was attributed to RF-induced rate increase of free radical reactions taking place in the presence of Fe²⁺ (Haber-Weiss/Fenton reaction, see section “EMF-induced oxidative stress via the radical pair mechanism”), where both geminate and freely-diffusing free radical pairs are produced⁵ by the unpaired electrons containing substrates/products Fe²⁺, Fe³⁺, O₂^{•-} and H₂O₂.

EMF dependence of enzymatic reactions via radical pair recombination

The free radical pair mechanism could also function synergistically and in parallel with an EMF-induced decrease of the natural antioxidant defenses. These depend on the overall cell metabolism controlled by numerous biochemical reactions, especially those involving reactive oxygen species (ROS) such as O₂^{•-}, OH[•] and H₂O₂, and reactive nitrogen species (RNS) such as nitric oxide radical (NO[•]), peroxyxynitrite (ONOO⁻) and nitrite ion (NO₂⁻). Chemical reactions are sensitive to external magnetic fields and biochemical reactions are expected to be sensitive as well. In optimized chemical systems, the change in chemical reaction rate is typically less than 50%^{7,34-36}. On the basis of these EMF effects, six criteria have been proposed for a magnetic field to affect an enzyme reaction^{14,37}: (1) one step in the reaction mechanism should involve a catalytically competent radical pair enzyme-substrate complex; (2) the free radicals that constitute the pair must be “weakly coupled”, that is, being apart by at least 0.6 nm; (3) there must be a mechanism for the interconversion of singlet (antiparallel electron spins) and triplet (parallel electron spins) states of the radical pair; (4) the radical pair must live long enough to allow significant S–T interconversion to take place; (5) the rate of the enzyme reaction must be sensitive to the concentration of the radical pair; and (6) the reaction steps that precede the formation of the enzyme–substrate complex must be reversible such that the commitment to catalysis is low.

EMFs can affect typical Michaelis-Menten biochemical reaction kinetics scheme based on a developed model³⁸ that involves an intermediate enzyme-substrate complex where a spin-correlated radical pair state exists. This model calculates the enzyme reaction rate explicitly by combining chemical kinetics with magnetic field-dependent spin kinetics that takes into account pair radical recombination probability (radical pair mechanism). The size of the magnetic field effect depends on relations between different rate constants, such as 1) the ratio between radical pair-lifetime and the rate of magnetic field-sensitive intersystem crossing induced by the hyperfine interaction, and 2) the chemical rate constants of the enzyme reaction cycle. An amplification factor, derived from the specific relations between the rate constants, accounts for the fact that although the magnetic field-induced change in radical pair recombination probability is very small, the effect on the enzyme reaction rate is considerably larger, for example, by a factor of 1 to 100³⁸. Model simulations enable a qualitative comparison with recent experimental studies reporting magnetic field effects on coenzyme B₁₂-dependent ethanolamine ammonia lyase (coB₁₂-EAL) *in vitro* activity that revealed a reduction in V_{max}/K_M at low flux densities and a return to the zero-field rate or an increase at high flux densities³⁹. The kinetic parameter V_{max}/K_m (where K_m is the Michaelis constant) for the coB₁₂-EAL was decreased 25 percent by a static magnetic field near 0.1 T with unlabeled ethanolamine and decreased 60% near 0.15 T with perdeuterated ethanolamine. This effect is likely caused by a magnetic field-induced change in intersystem crossing rates between the singlet and triplet spin states in the [cob(II)alamin:5'-deoxyadenosyl

radical] spin-correlated radical pair.⁴⁰ The magnetic field dependent step in coB_{12} -EAL is radical pair recombination.³⁹ The documented increase in the lifetime of free radicals by EMFs leads to elevated free radical concentrations for extended periods of time^{32,39}.

Organisms contain many enzymes that use free radicals or other paramagnetic molecules as reaction centers, intermediates, substrates or products. A typical magnetic-field sensitive biochemical reaction is the reduction of hydrogen peroxide by the plant enzyme horseradish peroxidase (HRP). Changes in catalytic rates of up to 30% were found for fields up to 0.3 T^{41-45} . Another example of EMF-sensitive enzyme, mammalian this time, is the rat cerebellum free radical nitric oxide (NO) synthase, which exhibited a statistically significant increase (11.2%) in activity when exposed to pulsed DC magnetic field (0.1 mT, for 1 hr)⁴⁶. Important enzymes with paramagnetic reaction centers (and thus prone to external EMF effect) are those containing iron-sulfur reaction centers (most frequently, Fe_2S_2 , Fe_3S_4 , and Fe_4S_4 clusters). They are found in all life forms, with typical example the mitochondrial Krebs cycle mammalian aconitase and the complexes I, II and III of the mitochondrial electron transport chain. These modular clusters undergo oxidation-reduction reactions, may be inserted or removed from proteins, can influence protein structure by preferential side chain ligation, and can be interconverted. They are involved in electron transfer, act as catalytic centers and sensors of iron, dioxygen and free radicals such as $\text{O}_2^{\cdot-}$ and NO^{\cdot} , and their most common oxidation states are paramagnetic via electron spin-dependent delocalization that arises in delocalized mixed-valence systems^{47,48}. Moreover, mobile phone emission was shown to interfere with electron transfer processes that take place during enzymic reactions catalyzed by oxidases and peroxidases. These reactions proceed by generating free radical intermediate compounds, which are paramagnetic species sensitive to electromagnetic fields. Microwaves emitted by a dual band mobile phone (915-1822 MHz) altered the steady-state transition complex formed by these enzymes⁴⁹.

The most promising candidates for EMF-induced oxidative stress effects are mammal (and man) membrane bound heme-enzymes such as the mitochondrial cytochrome *c* oxidase (i.e. Complex IV)³⁷ and complexes I, III, both of which can produce $\text{O}_2^{\cdot-}$ by a single electron leaking to dioxygen. There are also enzymes that catalyze reactions that produce ROS ($\text{O}_2^{\cdot-}$, OH^{\cdot} , H_2O_2), such as the $\text{O}_2^{\cdot-}/\text{H}_2\text{O}_2$ -forming xanthine oxidase⁵⁰, the $\text{O}_2^{\cdot-}$ -forming NAD(P)H oxidase¹⁶ and possibly cyclooxygenases/lipoxygenases. In addition, there are enzymes involved directly/indirectly in RNS formation (NO^{\cdot} , ONOO^- , NO_2^{\cdot}), such as the NO^{\cdot} synthase⁵¹; peroxyinitrite (ONOO^-), in particular, is a powerful biological oxidant that can be generated by $\text{O}_2^{\cdot-}$ and NO^{\cdot} ¹⁶.

On the level of organism (and man) enzymatic antioxidant mechanisms, superoxide dismutase (SOD) - both cytoplasmic (CuZnSOD) and mitochondrial (MnSOD) - is another enzyme candidate for positive EMF effect via the pair radical mechanism. This important antioxidant enzyme catalyzes the dismutation (and thus neutralization) of two superoxide free radicals into O_2 and H_2O_2 ⁵². Having already stated that the half-life of superoxide radical is near 100 ns^{20} , an expected EMF-induced spin rephasing on superoxide radicals (experiencing different local fields due to their attachment to different biological molecules, or to SOD active site not in an identical way⁵³) may not allow their spontaneous or SOD-mediated reaction with each other, respectively, to form O_2 and H_2O_2 . In either case, EMFs may allow time for superoxide radicals to damage (directly and indirectly) important biological molecules (and DNA), and this may result in increased oxidative stress¹⁶. Moreover, ESR experiments have shown hyperfine coupling due to the presence of hydroxyl radical in the active site of CuZnSOD in the presence of

its natural product hydrogen peroxide, suggesting the possibility of SOD reaction reversal, and thus reformation of superoxide radical (from O_2 and H_2O_2). Another possible SOD reaction outcome would be the formation of a copper-bound hydroxyl radical⁵⁴. These finely tuned radical involving reactions of SOD could be possibly affected by EMFs, making the antioxidant enzyme act as an oxidant.

Amplification of EMF-induced effects on biological systems via the free radical pair mechanism

Biological effects from low strength EMFs are strongly dependent on the lifetime of the free radical pair, and consequently on the parameters affecting diffusion in the location where the pair is formed. Free radicals have been observed experimentally to escape recombination in the geminate cage in the presence of a very low (non-thermal) electromagnetic field and diffuse into the surroundings with possible harmful oxidative effects, and 30% is suggested to be possible¹⁵. If we assume the lowest reported case of 1% increase in non-recombined free radicals⁵, it can be suggested that it is very small to be harmful for the body's sophisticated antioxidant defense mechanisms under normal conditions. However, even these very low levels of escaped free radicals can become biologically harmful if the free radical pair mechanism functions synergistically with amplification biological mechanisms (e.g., EMF-induced signal transduction pathways, high free iron, etc.) and environmental stimuli (e.g., pollution factors) that would amplify the biological effect resulting from the EMF-induced small increase of free radical concentration. That is, EMFs can provoke a disproportionate biological response via biological amplification/induction of small chemical effects. Such oxidative stress-related amplification phenomena have been already documented experimentally (see section "EMF-induced oxidative stress via the radical pair mechanism").

Increased free radical concentrations in biological systems from weak EMF exposure may be quite harmful. In metabolic signal transduction chain reactions a single radical may result in the production of thousands of product molecules; biological reactions sometimes involve high gain non-linear amplifiers; and autocatalytic reactions, with chemical feedback steps, show non-linear responses to changes in reactant concentrations. In a physiological context, the small increases in radical concentrations that might arise from EMF effects should be seen in the light of antioxidant protection mechanisms against free radical attack. It is barely conceivable that biological systems in general are so finely balanced that a small change in radical concentration might have a direct effect. However in the presence of an efficient amplification mechanism, the situation can change, as if a field is applied to a system in which the defense mechanism is already severely challenged.

Amplification mechanisms depend on non-linear dynamic phenomena, which are necessary prerequisites for the creation, stabilization, and maintenance of specific states of order and function. Rhythmic phenomena are of fundamental importance for specific dynamic states of order and function in biology. The creation and stabilization of periodic states within biological systems is based on non-linear internal processes. They allow for the occurrence of temporal, spatial, or spatio-temporal structures within the system, with most prominent examples non-linear oscillations, exhibiting a regular (periodic or quasiperiodic) or an irregular (chaotic) motion. Non-linear dynamics (nonlinear equations of motion) create these regular and irregular states via self-organizing stochastic processes³.

Stochastic amplification can be exercised by cells/organisms through noise-induced bistability with oscillations, where the external noise may induce a bistable oscillatory (dynamic switching) behavior that is both quantitatively and qualitatively different from what is predicted or possible deterministically. The noise required to produce these distinct properties can itself be caused externally (e.g. by EMFs) and internally (by biochemical stimulants), making it feasible for biological systems of sufficient complexity to generate such behavior internally. This dynamics then induces stochastic amplification of signal transduction, gene expression, GTPase cycles, mitogen-activated protein kinase (MAPK) cascades, glucose mobilization, cell division/apoptosis, checkpoint control, actin treadmilling, membrane transport etc., and of metabolism in general. The main evolutionary design objectives to select for these cycles and cycle cascades are considered to be the need for switch-like elements that convert graded increases in an input to a more binary output and the demand for signal amplification, which may be necessary because the primary messengers are often present in extremely low concentrations⁵⁵.

Living organisms exhibit natural electrical oscillations as well, seen over a wide range of metabolizing systems, from primitive bacteria to man, with such coherent excitations associated with cell membrane⁵⁶ and thus with normal cell metabolism, cell-cell communication and organism function as a whole. Natural oscillations can be related e.g. to the interfacial membrane transport of hydrogen ions, to the low-frequency collective motion in biomacromolecules, to internal oscillations or photo-dissociation of solitons in alpha-helix protein molecules, to excitation of spin states in molecules or in intermediate complexes⁵⁶. The oscillation frequencies extend from the sub-Hz to the microwave (10^{10} - 10^{12} Hz) frequency region³ and can create ELF/RF-induced resonances in biological materials. For example, neurons of the basolateral amygdaloidal complex exhibit intrinsic oscillations⁵⁷, and CA3 neurons exhibit coherence and stochastic resonance in the 4–8 Hz range⁵⁸.

The interactions of the internal self-oscillating non-equilibrium biological states with external EMFs can result in many state transitions such as synchronization, sub- and super-harmonic resonances, an extreme frequency and intensity sensitivity, very sharp resonances, continuous and discontinuous frequency and amplitude changes, etc.³ This has been shown experimentally, more than two decades ago, by the effect of (1) microwave frequency and intensity on cellular response and (2) by ELF on signal transduction events in cells. In the first experiment, in single yeast cells synchronized in G1-phase and exposed to 41.7 GHz, over three growth cycles, at 0.01 W/m², 10 μW/m², and 0.05 μW/m² the growth rate was reduced up to 20%. These radiation intensity values correspond to a mean electric field of 1.9 V/m, 61 mV/m, and 4.3 mV/m, and to a mean specific absorption rate (SAR) of 40 mW/kg, 0.04 mW/kg, and 0.2 μW/kg, respectively (fig. 4). The effects showed a strong dependence on frequency in a resonant-like fashion even at drastically reduced intensity^{3, 59, 60}. In the second experiment, Ca²⁺ transduction (transport across the cell membrane) was studied on rat thymic lymphocytes exposed to a (non thermal) 60-Hz sinusoidal magnetic field. It was found that after the addition of an activator (the mitogenic plant lectin concanavalin A) of the membrane-mediated signal transduction cascade in these cells, the field stimulated the Ca²⁺ uptake on the average up to 170%⁶¹. However, when a 3-Hz square-wave magnetic field was used in similar experiments the Ca²⁺ uptake by mitogen-activated lymphocytes was reduced by 45-70%^{62, 63}. The results demonstrate that cellular signal transduction pathways can be measurably influenced by non-thermal ELF field intensities. Additionally, these findings

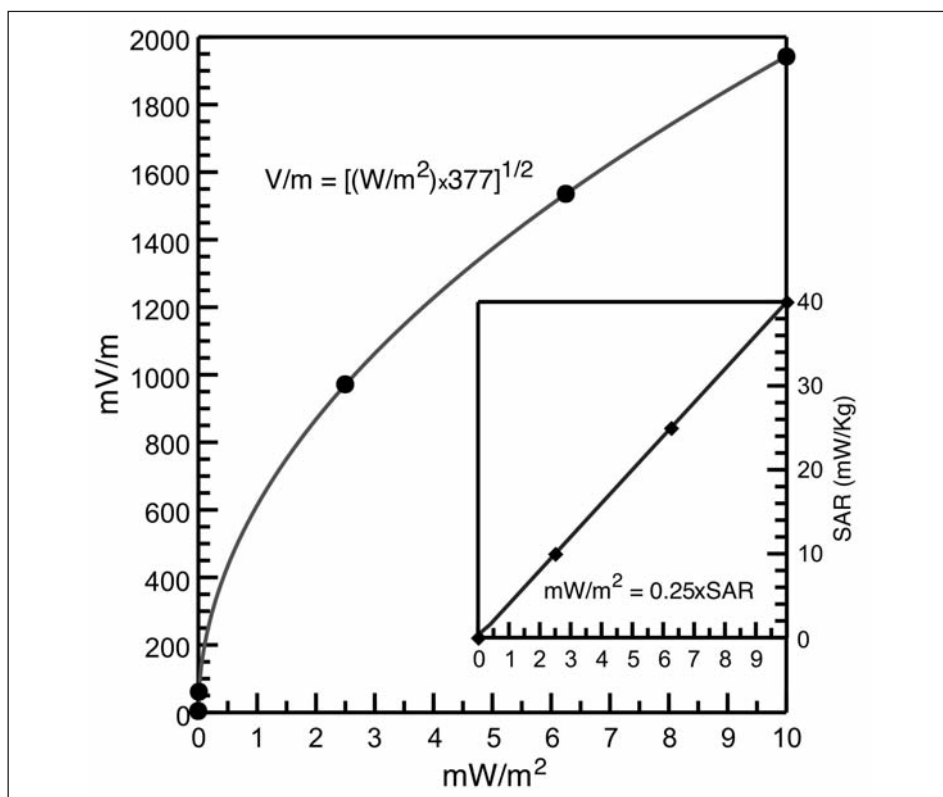

Fig. 4. Relationship among the main three unit expressions of EMF exposure limits. It is based on the formula $W/m^2 = (V/m)^2/377$, where 377 is the field resistance of air (in Ohms). The mean electric field (in V/m) is a square root function of the energy flux density (in W/m^2 , and so is the mean magnetic field [$A/m = [(W/m^2)/377]^{1/2}$]. Insert shows that SAR (in mW/Kg) is analogous to the radiation energy flux density (in mW/m^2), as pertaining to single yeast cell exposure at 41.7 GHz.³ Radiation energy flux density (and SAR) represents EMF biological exposure more accurately than the mean electric field component of EMF (normally used for expressing EMF radiation exposure limits) since electric and magnetic fields do not form separately in RF (higher than 300 MHz). This inadequacy is demonstrated by the following example: For a 250-fold exposure increase from 0.01 to 2.5 mW/m^2 , the corresponding exposure increase in mV/m (from 61 to 955) is only 16 fold. Radiation exposure misrepresentation using V/m gets even worse at lower exposure values

also show that biological parameters (i.e., the activation status) can be as important as physical EMF exposure parameters (i.e., intensity, frequency) in triggering field effects.

Sharp resonances found in the yeast experiments and the field influence on Ca^{2+} -mediated signal transduction events are two typical examples for illustrating the general idea of EMF coupling to a non-linear biological (e.g., membrane) oscillator, which in turn is coupled directly or via a chemical pathway to the internal oscillator. This process uncovers the potential of cells to amplify weak external stimuli and thus the ability to actively enhance the signal-to-noise ratio (e.g., even of EMFs modestly increased concentrations of free radicals) of received low-energy signals. EMF interactions have been studied primarily with the plasma membrane and membrane-mediated signal transduction processes. In any such interaction the primary excitation localized, e.g., some-

where on the membrane, must be translated into some persistent biochemical change in order to generate a downstream cellular effect. In some cases the sensitivity reaches the basic physical limit. For example, the ability of (1) photoreceptors to detect single photons, (2) hair cells to sense tiny displacements in the order of only a few Angstrom, or (3) cells of the olfactory system to sense only one or a few molecules is proof of the surprising ability of some specialized cell types to respond to extremely weak signal inputs in the presence of biological noise. Molecular studies of membrane signaling processes have shown, for example, that the involved cells can use mechanisms such as intracellular second-messenger (e.g., Ca^{2+} , cAMP, cGMP) cascades, positive feedback, and non-linear membrane channel-gating³.

Weak EMFs may be received and processed by cells in a manner reminiscent of sensory transduction by two ways: (1) Primary biological receptors may also act as primary EMF receptors and (2) enzymatic steps in the cellular transduction/amplification pathways may be sensitive to EMFs, even in cells which are not considered specialized sensory cells (e.g., cells of the immune, nervous, or musculo-skeletal system). There is evidence that cytochrome *P-450* and cytochrome-catalyzed reactions, which involve transient radical pairs, can be affected by weak magnetic fields^{4, 64}. This free radical pair/amplification synergism explains the ability of animals, and in particular birds, to sense the Earth's magnetic field as a source of navigational information during migration^{65, 66}. For example, when robins were exposed to vertically aligned broadband (0.1-10 MHz) and single-frequency (7 MHz) oscillating EMF of magnitude only 85 and 470 nT, respectively, the birds were disoriented⁶⁷. The suggested radical pair biochemical magnetoreceptor is located in the bird's retina, and an extraordinarily efficient process involving the visual transduction pathway amplifies the primary response to the geomagnetic field. This, together with the increasingly recognized importance of oxygen free radicals and nitric oxide in cellular regulation and signaling¹⁶, points towards a sensible EMF interaction mechanism based on electron spin-mediated field effects.

The free radical pair mechanism can also explain the hypothesis that magnetic nanoparticles, found in many organisms, mediate EMF-induced DNA damage which could result in increased risk of childhood leukaemia and other cancers. The naturally occurring magnetic field generated by a magnetic nanoparticle within a cell is calculated to be in the range of about 1-200 mT, which exceeds the level of the natural geomagnetic field by orders of magnitude. It has been shown that magnetic nanoparticles can increase the rate of free radical formation by a few percent, in the course of an idealized radical-pair reaction in a cell, and a mechanism has been proposed to explain how weak alternating magnetic fields, of the order of 0.4 μT , could cause an increase in the rate of leukaemia via mT fields produced around superparamagnetic nanoparticles in hematopoietic stem cells⁶⁸.

EMF-induced oxidative stress via the free radical pair mechanism

EMF (RF-ELF) and SMF effect via the free radical pair mechanism enhanced or not by amplification/signal transduction biochemical processes, can be exhibited by two plausible biological mechanisms involving free radicals. The first involves increased reactive oxygen and nitrogen species (ROS and RNS, respectively) and genetic damage as a response to EMF exposure. The second involves increased ROS and genetic damage because of an induced decrease of natural free radical scavenger levels, that is, decreased

antioxidant defense. With either mechanism, the net result is creation of oxidative stress. As it will be documented in the following chapter, oxidative stress has been developed in various biological experimental systems after low-level exposure to both ELF and RF, which suggests that the free radical mechanism presented above holds true for the entire EMF spectrum and SMF.

Metabolic processes that generate oxidants and antioxidants can be influenced by environmental factors, such as EMFs. Increased EMF exposure can modify the activity of the organism by reactive oxygen species leading to oxidative stress. It is well established that free radicals can interact with DNA resulting in single strand breaks. DNA damage could become a site of mutation, a key step to carcinogenesis. Furthermore, different cell types react differently to the same stimulus, because of their cell type specific redox status. On the other hand, modulation of antioxidants by ELF-EMF can lower the intracellular defense activity promoting the development of DNA damage. It has also been demonstrated that low levels of reactive oxygen species trigger intracellular signals that involve the transcription of genes and lead to responses including cell proliferation and apoptosis⁶⁹.

Oxidative stress is caused by an imbalance between the production of ROS/RNS and the biological system's ability to readily neutralize the ROS/RNS molecular components and/or easily repair the resulting damage. The most biologically destructive feature of oxidative stress is its concurrence with the production of highly oxidative oxygen and nitrogen species which are composed of both free radicals and peroxides (Table 1)^{16, 70-72}. The less reactive of these can be converted to highly reactive free radicals by redox reactions with transition metals (Fe and Cu, constituents of proteins) and biological redox cyclers such as quinones.⁷³ ROS and RNS are continuously generated under normal conditions. If their levels are not kept low by antioxidant mechanisms, they are capable of attacking lipids, nucleic acids and proteins, resulting in various degrees of oxidative damage¹⁶.

1. Reactive oxygen and nitrogen species

The term reactive oxygen species (ROS) has been used to refer to all species of oxygen that are more reactive than oxygen in its ground (O_2) or triplet (3O_2) state. These are, dioxygen in its two excited state singlet forms (1O_2), and the partially reduced forms of oxygen (i.e., superoxide radical ion and its protonated form $O_2^{\cdot-}$ and HO_2^{\cdot} , respectively), hydroxyl radical (OH) and hydrogen peroxide (H_2O_2). Superoxide radical is the most important ROS component and central element of oxidative stress because it is usually formed first in cells and it is the main source of other important ROS components (Table 1). Specifically, it is generated from molecular oxygen being reduced by a single electron. The next ROS in series is hydrogen peroxide, formed by superoxide radical capturing an electron from another superoxide radical molecule (dismutation reaction). Finally, the very potent hydroxyl radical is formed from hydrogen peroxide that captures an electron from another superoxide radical molecule or from free ferrous (Fe^{2+}) and cuprous (Cu^{1+}) ions (released e.g. from proteins oxidatively modified under abnormal conditions). Another important ROS component is singlet oxygen (1O_2), which can result from the reaction between two peroxide radicals resulting from the oxidative attack of cell membrane lipids by ROS or by UV-excitation of molecular oxygen.

ROS, like superoxide radical, are produced by various sources; e.g., from electron leaking mitochondria, and from biochemical reactions catalyzed by the enzymes

Table 1 - Reactive oxygen/nitrogen species and their contribution to oxidative stress

ROS and RNS	Formation and function
$O_2^{\cdot-}$ (superoxide free radical anion)	One-electron reduction state of O_2 : it is formed in many autoxidation and redox cycling reactions, and by electron leaking in the mitochondrial respiratory chain. It can release reactive Fe^{2+} from proteins with iron-sulfur centers and from the iron storage protein ferritin. Two moles of it dismutate to form H_2O_2 spontaneously or by enzymatic catalysis (via the antioxidant enzyme superoxide dismutase). Moreover, it is a precursor for the metal-catalyzed hydroxyl radical formation via the Haber-Weiss/Fenton reaction.
H_2O_2 (hydrogen peroxide)	Two-electron reduction state of O_2 : it is formed by the dismutation of 2 moles $O_2^{\cdot-}$, and by the direct reduction of O_2 . It can easily diffuse across cell membranes. OH (hydroxyl free radical) Three-electron reduction state of O_2 : it is formed by the Haber-Weiss/Fenton reaction and from decomposition of peroxynitrite. It is highly reactive and can attack most cellular components indiscriminately.
RO \cdot and ROO \cdot (mainly lipid alkoxy and peroxy free radicals)	Mostly lipid peroxidation process-associated oxygen centered organic radicals, produced by free radical addition to double bonds or after hydrogen abstraction from lipids.
ROOH (mainly lipid hydroperoxides)	It is formed by radical reactions with important cellular components such as membrane phospholipids (known as lipid peroxidation process).
HOCl (hypochlorous acid)	Reaction product of myeloperoxidase-catalyzed oxidation of H_2O_2 . Highly reactive and easily diffusible across cell membranes. It damages proteins by readily oxidizing thiol and amino groups.
NO (nitric oxide free radical)	Formed enzymically by nitric oxide synthase via five-electron oxidation of L-arginine. It is a powerful biological oxidant.
ONOO \cdot (peroxynitrite)	Product of the reaction between $O_2^{\cdot-} + NO$. Highly reactive (as hypochlorous acid) and easily diffusible across cell membranes. In its protonated form (i.e. peroxynitrous acid) can undergo homolytic splitting to form the highly reactive hydroxyl free radical (and nitrogen dioxide).

xanthine oxidase, NAD(P)H oxidases, cyclooxygenases and cytochromes *P-450* (fig. 5). Hydrogen peroxide is produced by a wide variety of enzymes including several oxidases (e.g. glucose oxidase)¹⁶. Certain organic compounds can also produce ROS. The most important are the quinones which can redox cycle with their conjugate semiquinones and hydroquinones, and in some cases catalyze the production of $O_2^{\cdot-}$ from O_2 or H_2O_2 from $O_2^{\cdot-}$. Cells possess efficient antioxidant defense systems, composed mainly of antioxidant enzymes such as superoxide dismutases (SOD), glutathione peroxidase (GPx) and catalase (CAT), which can scavenge the oxygen free radicals excessive for cellular metabolism, and make their level relatively stable under physiological conditions (fig. 6). ROS physiological concentrations are under the control of the main antioxidant enzymes working in collaboration with auxiliary antioxidant enzymes such as peroxiredoxins and sulfiredoxin, and with other enzymes having secondary antioxidant role such as paraoxonase, glutathione-S transferases, and aldehyde dehydrogenases¹⁶.

Transition metals such as iron, copper, cobalt and vanadium, freed from their enzyme hosts after oxidative attack, are capable of redox cycling (accepting and donating in cycle single electrons). This cyclic process catalyzes reactions that produce ROS, with

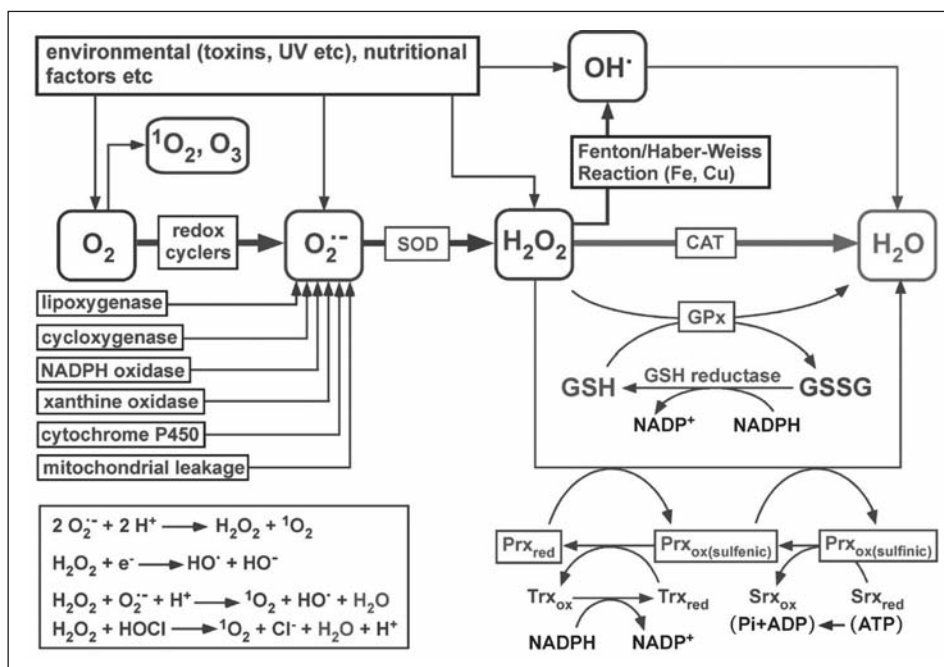
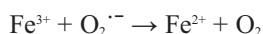

Fig. 5. Mechanism of ROS production and enzymatic antioxidant protection: ROS are produced either by atmospheric molecular oxygen excitation into ozone and singlet oxygen (O_3 , 1O_2 , respectively) or by reduction into superoxide radical, hydroxyl radical and hydrogen peroxide ($O_2^{\bullet-}$, OH^\bullet , H_2O_2 , respectively). Species O_3 , 1O_2 , $O_2^{\bullet-}$, OH^\bullet and H_2O_2 are most reactive. Superoxide radical can be generated enzymically and non-enzymically, and can react with another superoxide radical as well as with other radicals, while H_2O_2 reacts with the iron sulfur centers and cysteines of certain proteins. However, both superoxide and hydrogen peroxide can spontaneously form singlet oxygen and hydroxyl radicals, which are much more reactive. The main reactions for 1O_2 , $O_2^{\bullet-}$, and OH^\bullet are shown. Superoxide is dismutated by superoxide dismutases (SOD), and H_2O_2 is decomposed by catalase (CAT), peroxidases (such as glutathione peroxidase, GPx), and by peroxiredoxins (Prx). The thiol group of a sensitive cysteine (Cys) in Prx is oxidized to a Cys-sulfenic acid (Prx_{ox}) and is reduced by reduced thioredoxin (Trx_{red}). The Cys-sulfenic acid in Prx_{ox} can be further oxidized by H_2O_2 to Cys-sulfinic acid, which is reduced back to Cys-sulfenic acid by the reduced sulfiredoxin (Srx_{red}) and ATP. *iation exposure misrepresentation using V/m gets even worst at lower exposure values*

most important the Haber-Weiss/Fenton reaction that forms OH^\bullet from Fe^{2+} and H_2O_2 . The OH^\bullet then can oxidatively modify amino acids (e.g., attack phenylalanine to form *meta*- and *ortho*-tyrosine), carbohydrates, initiate lipid peroxidation, and oxidize nucleobases. Most enzymes that produce reactive oxygen species contain one of these metals. The presence of such metals in biological systems in free form (not complexed in a protein or in a metal complex) can significantly increase the level of oxidative stress.

The Haber-Weiss/Fenton reaction is catalyzed mainly by free iron (as well as by copper)^{16,74,75}, with the first step of the catalytic cycle involving reduction of ferric to ferrous ion:



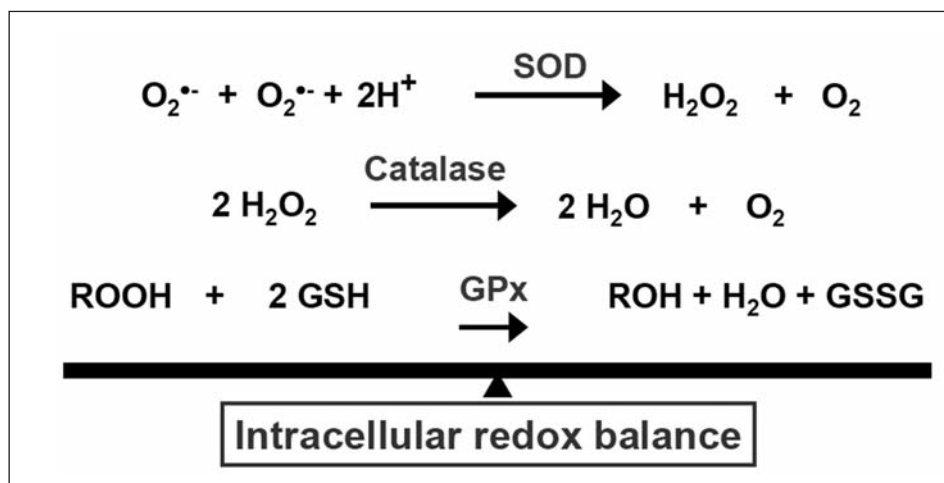
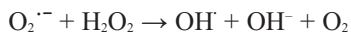

Fig. 6. Antioxidant enzymes mainly maintain reactive oxygen species-regulated intracellular redox balance. Superoxide dismutase (SOD) converts superoxide radical to hydrogen peroxide, which, in turn, is neutralized to molecular oxygen by catalase (CSAT). Hydrogen peroxide and other toxic biological hydroperoxides (ROOH) such as lipid hydroperoxides (byproduct of lipid peroxidation) are also neutralized by glutathione (GSH) peroxidase (GPx) and are converted to alcohols (ROH). The resulting oxidized glutathione (GSSG) is converted back to GSH by the enzyme glutathione reductase at the expense of NADPH (not shown)

The second step is the Fenton reaction⁷⁶,



and the net reaction is



This metal-catalyzed reaction can occur in cells and is therefore a possible source for increased oxidative stress and genotoxicity.

High oxidative stress can also result from increased reactive nitrogen species (RNS) such as nitric oxide radical (NO^\cdot), peroxynitrite (ONOO^-) and nitrite ion (NO_2^-); especially peroxynitrite, is a powerful oxidant and nitrating agent. Because of its oxidizing properties, peroxynitrite can damage a wide array of molecules in cells, including DNA⁷⁷ and proteins. With proteins in particular, it is involved in nitration of tyrosine residues. Dysfunction of proteins due to nitration has been related to several cardiovascular diseases, including autoimmune myocarditis, hypertension, and heart failure⁷⁸. Nitric oxide (NO) is a central molecular component of RNS. It is produced by nitric oxide synthase via five-electron oxidation of a guanidino nitrogen of L-arginine (L-Arg) to L-citrulline, which occurs by the following two successive monooxygenation reactions producing intermediate *N*^ω-hydroxy-L-arginine (NOHLA):

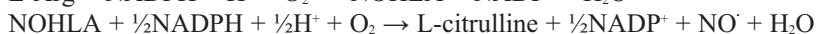
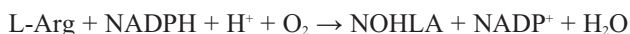

Formation of peroxynitrite *in vivo* has been ascribed to the reaction of the free radical

superoxide with the free radical nitric oxide⁷⁹, with the latter formed by nitric oxide synthase⁵¹:

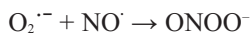

The resultant pairing of these two free radicals results in the formation of peroxy-nitrite, which is not a free radical but a powerful oxidant. Conversion of NO[·] (by O₂^{·-}) to the toxic ONOO⁻ undermines NO[·] antioxidant rôle in regulating lipid peroxidation induced by ROS⁸⁰. NO in lipid reactions is important since (a) it significantly concentrates in lipophilic cell compartments, thus enhancing its ability to regulate oxidant-induced membrane lipid oxidation, and (b) it reacts with LO[·] and LOO[·]⁸¹.

2. Oxidative stress-induced biological damage upon EMF exposure via the Haber-Weiss/Fenton reaction

In order for the Haber-Weiss/Fenton reaction to take place, and thus cause serious biological damage, it requires the presence in cells and biological fluids of free transition metals, such as iron (Fe) and copper (Cu), together with organic peroxides (e.g. hydrogen peroxide, lipid hydroperoxides)¹⁶. Metabolically active cells require high respiration rates, which, in turn, create high electron flux via the mitochondrial electron transport chain. This results in an increase of electron leaks (mainly from coenzyme Q-cycling in Complex III) to molecular oxygen and the formation of superoxide radical. The Haber-Weiss/Fenton reaction can take place in organisms *in vivo* because Fe can be released from [Fe-S]-containing enzyme centers upon superoxide radical and peroxy-nitrite attack. For instance, an important enzyme that could leak iron from its [Fe-S] cluster upon such attack is the mitochondrial aconitase⁸²⁻⁸⁷. Candidates for the Haber-Weiss/Fenton reaction are cells undergoing abnormal proliferation, having high concentration of free (labile) iron and being under ROS/RNS-associated redox signaling control such as cancer cells⁸⁸. Another iron source comes from superparamagnetic iron-particles (magnetites) in body tissues, particularly in the brain⁸⁹. Such example is the dopamine and 6-hydroxydopamine-mediated free iron release from ferritin magnetic nanoparticles, which may lead to substantial lipid peroxidation (via the Haber-Weiss/Fenton reaction) of the substantia nigra in the brain, and explains the pathogenesis of fever-induced Parkinson's disease⁹⁰. In general, metal ions such as Zn, Fe and Cu are known to participate in neurobiological processes, and major neurodegenerative disorders such as Alzheimer's and Parkinson's diseases are characterized by elevated tissue Fe and miscompartmentalization of Cu and Zn⁹¹. Such high iron situations could enhance free radical activity in cells and cellular-damaging effects that could be amplified by EMF exposure. There is ample experimental evidence supporting this hypothesis throughout the entire electromagnetic spectrum, steady magnetic fields (SMF), ELF's and RF's, and in the presence of free iron it is attributed to EMF-induced rate increase of the free radical-forming Haber-Weiss/Fenton reactions, where both geminate and freely-diffusing free radical pairs are produced since the involved reaction substrates/products Fe²⁺, Fe³⁺, O₂^{·-} and H₂O₂ possess unpaired electrons^{5,33}. Oxidative stress-inducing biological damage (e.g. involved in carcinogenic and neuro-generative) upon EMF exposure can also result by other metals such as heavy metals⁹².

SMF/ELF effects: The involvement of copper in Haber-Weiss/Fenton reaction-induced lipid peroxidation was shown indirectly in an *in vivo* study involving steel

workers working from 3-10 years and more than 10 years at processing shops in the presence of a heater where they were exposed to 50 Hz (1.3 mT). Lipid peroxidation was increased by 28% and 56%, respectively, accompanied by decreased ceruloplasmin levels (by 41% and 54%, respectively)⁹³, suggesting that the released copper due to decrease of ceruloplasmin contributes in the increased generation of free radicals. In Fe²⁺-pre-treated rat lymphocytes exposed to 50 Hz (20, 40, 200 μT, for 1 hr) ROS levels (measured non-specifically with fluorescent dichlorofluorescein diacetate) were increased by 14%⁹⁴, and in a similar study with isolated rat-liver microsomes simultaneously Fe²⁺-treated and exposed to a SMF (5 mT, for 40 min) lipid peroxidation was increased up to 12%⁹⁵. In another experiment, intact erythrocytes incubated with Fe²⁺/ascorbate mixture and exposed also to SMF (0.5 mT) induced a 20% decrease in hexokinase activity and a 100% increase in methaemoglobin production⁹⁶. The involvement of the Haber-Weiss/Fenton reaction was also shown in rat peripheral blood lymphocytes exposed to 50 Hz (7 mT, for 3 hrs) with/without pre-treatment with melatonin and ferrous chloride. DNA damage was significantly increased by 690% in lymphocytes only after simultaneous exposure to ELF and treatment with iron, while treatment with antioxidant melatonin prior to ELF exposure reduced the amount of damaged cells in a concentration-dependent manner, clearly implying the involvement of ELF-amplified levels of free radicals in DNA damage⁹⁷. Similar effect was documented in rat (Wistar male albino) lymphocytes exposed to SMF or 50 Hz (7 mT, for 3 hrs), which caused increase in the number DNA damaged cells (by 20% or 15%, respectively) only when incubated with FeCl₂, and this was attributed to the substantial increase of ROS generated by Fe²⁺ via the Haber-Weiss/Fenton reaction⁹⁸. Moreover, in a study involving SMF exposure alone, rat peripheral blood lymphocytes pre-treated with FeCl₂ exhibited increased lipid peroxidation (by 152%), which was further amplified by an extra 23% when the cells were simultaneously treated with FeCl₂ and exposed to SMF (7 mT, for 3 hrs). In addition, simultaneous SMF/iron treatment caused a significant increase in apoptotic and necrotic cells (by 83% and 50%, respectively), accompanied by a decrease in cell viability (by 27%). All these effects were attributed to the Haber-Weiss/Fenton reaction mechanism⁹⁹.

RF effects: The Haber-Weiss/Fenton reaction-associated effect with RFs are very limited to a study that showed induction of ROS formation induced by the frequency carrier of signals emitted by a typical cellular phone. In Fe²⁺-treated rat (Wistar male albino) lymphocytes exposed to 930 MHz (continuous wave, at 5 W/m² corresponding to SAR 1.5 W/kg, for 5 and 15 min), a 16% increase of ROS (measured non-specifically by dichlorofluorescein diacetate) was observed³³.

3. EMF exposure amplifies oxidative stress-related metabolic processes by extracellular stimulants and signal transduction pathways

It has been already hypothesized that EMFs may provoke disproportionate oxidative stress response by amplification of their primary oxidative stress-inducing free radical effect. There is ample experimental evidence that this amplification phenomenon can be provoked by extracellular stimulants (e.g. environmental pollutants) as well as by non-linear intracellular processes (e.g. signal transduction pathways), with the latter being under the influence of oxidative stress. Oxidative stress has been known to affect directly enzymes participating in signal transduction pathways, especially those involved in Ca²⁺ homeostasis. For example, oxidative damage in the membrane enzymes Na⁺/K⁺-

ATPases and Ca²⁺-ATPases containing functional –SH groups (thus, vulnerable to oxidative attack by ROS/RNS) can disturb Ca²⁺ homeostasis, resulting in its intracellular accumulation. This, then, can lead to phospholipase and protease activation and Ca²⁺ accumulation in mitochondria, events that contribute to cell metabolism disturbance and eventually to cell death¹⁶.

ELF effects: We have already presented experimental evidence showing that increased intracellular free iron levels can amplify the initial increase in ROS formation (via the Haber-Weiss/Fenton reaction) upon ELF exposure^{33,94-100}. This phenomenon is observed by other ROS stimulants besides iron. For example, the combination of 60-Hz exposure (1.2 mT, for 3 hrs) and the oxidant *t*-butyl-hydroperoxide (an organic lipid hydroperoxide analogue) increased ROS (non-specifically measured by chemiluminescence) by 40% in mouse brain homogenates¹⁰¹, suggesting that ELF could deteriorate the antioxidant defense system via the Haber-Weiss/Fenton reaction, where lipid hydroperoxides in the presence of transition metals form cancer-promoting alkoxy free radicals¹⁰². The combination of 50 Hz-field exposure (40 μT, for 1 hr) and *in vitro* UVA irradiation (photochemical/free radical reaction inducing non-ionizing radiation) on rat lymphocytes caused the oxidative deterioration of DNA attributed to the oxidative stress-radical pair mechanism¹⁰³. The synergistic effect of 60-Hz exposure (0.1 mT, real time exposure) and of the ROS and tumour promoter phorbol 12-myristate 13-acetate (PMA) on rat peritoneal neutrophils increased by 12.4% their oxidative burst (H₂O₂ production, non-specifically detected by the 2',7'-dichlorofluorescein fluorescent probe)³². The same ROS stimulant (PMA), when combined with 60-Hz exposure (22 mT, for up to 10 min), induced in human neutrophils (PMN) a 26.5% increase of superoxide radical production (measured *in vitro* in cell culture by the SOD-inhibited reduction of ferricytochrome *c*) and a 53% increase of β-glucuronidase release (controlled by intracellular signaling)¹⁰⁴.

The association of signal transduction pathways with ELF effects was also shown by the following Ca²⁺ uptake studies, although the experimental approaches were not designed to investigate their relation with oxidative stress. Rat thymic lymphocytes exposed to 60-Hz (sinusoidal magnetic field, 1 mV/cm, for 1 hr) showed Ca²⁺ uptake increase by 2.7 fold after the addition of the activator concanavalin A (mitogenic plant lectin), and this stimulation of Ca²⁺ metabolism was attributed to a membrane-mediated signal transduction cascade in these cells⁶¹. The relation of calcium uptake and its metabolism with apoptosis (indirectly with oxidative stress) has been also shown in mouse lymphocytes¹⁰⁵.

Many other experiments with ELF (3-60 Hz, 0.02-22 mT) have documented various signal transduction-associated biochemical effects (e.g. 50-100% synthesis increase in *c-myc* and 30-50% increase in uridine uptake in HL-60 cells, 8% increase in cell cycle progression of phytohemagglutinin-activated human peripheral blood lymphocytes, etc), which are related to induced membrane-mediated Ca²⁺ signaling processes in cells of the immune system¹⁰⁶. Another ROS-dependent signal transduction pathway affected by ELF is the Na⁺-dependent choline uptake in brain cells of the central cholinergic systems. In this study, rats (male Sprague-Dawley) exposed to 60 Hz (up to 1 mT, for 45 min) showed a ~50% decrease in Na⁺-dependent, high-affinity choline uptake (HACU) (at ≥0.75 mT) in the frontal cortex and hippocampus brain synaptosomes. Pre-treating the animals with the narcotic antagonist naltrexone blocked such ELF effects. Given the fact that activity and subcellular trafficking of the Na⁺-coupled choline transporter is regulated acutely by peroxynitrite¹⁰⁷, naltrexone blocking effect can be attributed to its antioxidant action. It reduces inducible nitric oxide synthase activity (thus

decreases the formation of the free radical NO^\cdot and peroxy nitrite, its reaction product with $\text{O}_2^{\cdot-}$ in neuronal cells and oligodendrocytes¹⁰⁸. In humans, changes in cholinergic activity of the brain can lead to various neurological and psychiatric disorders, such as Alzheimer's disease¹⁰⁹.

ELFs can even induce ROS/RNS-controlled cell proliferation signal transduction pathways in animals and plants. This was shown in primary chick embryo fibroblast (CEF) cultures and in *Spirodela oligorrhiza* (a small aquatic plant, commonly known as Duckweed) exposed to 100 Hz (0.7 mT, for 24 hrs), where enhanced cell proliferation was observed. To demonstrate that free radicals may induce enhanced CEF proliferation, cells were exposed to the ROS production-inducing ascorbate/ Fe^{2+} system, which enhanced the rate of cell proliferation by 6% compared with control cells. In the absence of radical scavengers, cell proliferation was enhanced by 33% compared to the sham exposed cells, while in the presence of the antioxidant enzymes CAT and SOD, and of vitamin E, the enhancement of cell proliferation was reduced by 79, 67, and 82%, respectively, compared with their sham exposed cells^{110,111}. In another study with HL-60 cells, Rat-1 fibroblasts and WI-38 diploid fibroblasts exposed to 50 Hz (0.50, 0.75 and 1.0 mT, for 3–72 hrs) there was a 30% increase in cell proliferation of all cell types after 72-hr exposure to 1 mT, as well as 25% increase of the percentage of cells in the S phase for Rat-1 cells after 12-hr exposure. These effects were prevented by pre-treatment of cells with vitamin E, suggesting that free radical reactions were involved in this signal transduction-regulated amplification phenomenon¹¹².

SMF effects: Oxidative amplification was shown in the following experiment combining the effects of environmental and chemical factors with steady magnetic field (SMF) exposure. Combined SMF exposure (25-150 mT) and UVA (>300 nm) irradiation of the non-steroidal anti-inflammatory agent ketoprofen (KP) and erythrocytes, significantly speeded up the time required for cell photo-hemolysis via the oxidative stress-inducing radical pair mechanism¹¹³. This mechanism involves the initial generation of a triplet radical pair derived from the reaction of triplet state KP [or 3-ethylbenzophenone (3-EtBP)/UVA, the main photoproduct of KP which has the same chromophore as KP] with erythrocyte component(s) probably lipids. The applied SMF increased the concentration and/or lifetime of free radicals that escape from the radical pair so that the critical radical concentration needed to initiate membrane damage (lipid peroxidation) and the caused cell lysis is reached sooner. Free radical spin-trapping studies with the trap 2,6-dibromo-1-nitrosobenzene-4-sulfonate confirmed that the application of the external SMF increased the concentration of radicals released during the photolysis of either KP or 3-EtBP dissolved in media such as sodium dodecyl sulfate micelles. In another study, the combination of the potent chemical pollutant CCl_4 (injected to mice) and SMF exposure (at 4.7 T, for 3-48 hrs,) caused an increase of lipid peroxidation in liver and in glutamic-oxaloacetic transaminase and glutamic-pyruvic transaminase activities, thus enhancing hepatotoxicity¹¹⁴. SMFs can also induce signal transduction pathways such as the one regulating melatonin secretion¹¹⁵. This was shown by the decrease (21.7%) of pineal *N*-acetyltransferase activity (the rate limiting enzyme in melatonin production) and by the decrease in pineal and serum melatonin levels (by 8.7% and 43.5%, respectively) in rats exposed (during the night) at pulsed DC MF (turned on and off at 1-s intervals with a rise/fall time constant of 5 ms, ranging from 50 to 500 μT , with the bulk of the studies being conducted using a 100 μT). Because of melatonin's known direct free radical scavenging action, the drop in serum melatonin could be explained by an increased uptake of melatonin by tissues that were experi-

encing increased levels of free radicals (developed via the pair radical mechanism) as a consequence of SMF exposure¹¹⁶. SMFs can even induce the signal transduction pathways leading to apoptosis (ROS/RNS-controlled)¹¹⁷. This was shown in female rats where SMF exposure (128 mT, for 10 days, 1 hr/day) induced apoptosis via increase of free radical levels and resulted in a 30% decrease of thymus relative weight¹¹⁸.

RF effects: Amplification of the RF-induced free radical effect was shown in a study where human umbilical cord blood-derived monocytes and lymphocytes were exposed to 1800 MHz [continuous wave, or intermittent GSM-DTX (hearing only, 5 min on/5 min off) and GSM-Talk (34% speaking and 66% hearing), at SAR 2.0 W/kg, for 30 or 45 min], with PMA (ROS-inducing stimulant)-pre-treated cells used as ROS production (positive) control. After continuous or intermittent exposure to the GSM-DTX signal (for 45 min), the human monocytes displayed a significant increase (by 12%) of ROS production (non-specifically detected by dihydrorhodamine 123 fluorescence) due to the synergistic effect of PMA-induced/amplified ROS and RF-increased lifetime of free radicals¹¹⁹. The synergistic induction of signal transduction pathways by RFs was shown in a study with rats (Wistar, 35 day-old) exposed to 2450 MHz (0.34 mW/cm² corresponding to SAR 0.1 W/kg, for up to 35 days, 2 hrs/day). A significant increase in Ca²⁺ efflux (by 82% after 20 min and by 118% after 35 days), and in ornithine decarboxylase activity (by 247%) was observed in the exposed group as compared to the control. Correspondingly, a significant decrease in the Ca²⁺-dependent protein kinase activity (by 57%) was observed. These results indicate that RFs at 2450 MHz affect the membrane bound enzymes that are associated with signaling transduction pathways regulating cell proliferation and differentiation¹²⁰, with both of these important biological processes being controlled by ROS/RNS¹²¹. In another study, rats (adult male albino) were exposed (for 30 min/day, for 7 days, at speech or standby position) to a commercially available cellular telephone of the GSM 900 type (900 MHz, 2 W peak power, average power density 0.02 mW/cm²) caused massive exocytosis in Merkel (epidermal) cells¹²². It was concluded that Merkel cells could detect this RF by showing an exocytotic activity via signal transduction pathways, resulting in discharge of their granules that lead the changes. Oxygen free radicals are involved in this process since it has been shown that exocytosis in HL-60 cells can be induced by 4-hydroxynonenal, a well known oxidant product of the ROS-caused lipid peroxidation process¹²³.

4. EMFs invoke oxidative stress-induced DNA damage and cell apoptosis/necrosis

EMFs can cause biological damage via oxidative stress (i.e. via ROS/RNS)-induced DNA damage¹²⁴. This is mainly done by the ROS formed via the Haber-Weiss/Fenton reaction, especially by the extremely reactive hydroxyl radical¹²⁵.

SMF/ELF effects: SMF/ELF exposure-induced DNA damage has been related with the Fe²⁺-associated Haber-Weiss/Fenton reaction by studies showing increase of DNA strand breaks in rat brain cells (acutely exposed to 60 Hz, 0.5 mT, for 2 hrs)¹⁰⁰, by the 15%-20 % increase of rat lymphocytes with damaged DNA (when exposed to SMF or 50 Hz, 7 mT, for 3 hrs)⁹⁸, by the 690% increase of damaged DNA in rat peripheral blood lymphocytes (exposed also to 50 Hz, 7 mT, for 3 hrs)⁹⁷, and by the increase of apoptotic and necrotic cells (83% and 50%, respectively) also in rat peripheral blood lymphocytes, accompanied by a 27% decrease in cell viability (after SMF exposure, 7 mT, for 3 hrs)⁹⁹.

In another study (also using rat brain cells), increase of DNA strand breaks by a field dose-dependent (0.1, 0.25, and 0.5 mT, for 2 hrs) was documented, although not tested

for relation with oxidative stress. However, increase of DNA strand breaks in cells (including human cells) exposed to ELF has been associated with oxidative stress in a number of studies, since this genotoxic ELF effect was shown to be partly inhibited by free radical scavengers. Specifically, this effect concurred by the increase of ROS in three different cell experimental systems: in macrophages from murine bone marrow after exposure to 50 Hz field (0.5 -1.5 mT, for 45 min)¹²⁶, and in monocytes derived from umbilical cord blood and human monocytic leukaemia cell line, after exposure of both cell types to 50 Hz (1 mT, for 45 min)¹²⁷.

Indirect evidence for ROS involvement in ELF-induced genotoxicity and cell apoptosis/necrosis comes from a series of studies. For example, in rats exposed to 60 Hz (0.01-0.25 mT, for 2-48 hrs) brain cells showed oxidative stress-induced increases in DNA single/double strand breaks and also cell apoptosis/necrosis, since these effects were blocked by pre-treating the animals with the free radical scavengers melatonin, *N*-tert-butyl- α -phenylnitron and Trolox (a vitamin E analogue)^{10,128,129}. In another study with HL-60 cells, Rat-1 fibroblasts and WI-38 diploid fibroblasts exposed to 50 Hz (0.50, 0.75 and 1.0 mT, for 3-72 hrs), there was a dose-dependent increase in DNA damage (as strand breaks and 8-hydroxy-2'-deoxyguanosine formation). This effect was attributed to ELF-induced oxidative stress because it was cancelled by pre-treating cells with the antioxidant vitamin E¹¹².

Genotoxic effect (oxidative deterioration of DNA) was induced in rat lymphocytes by simultaneous UVA irradiation and exposure to 50 Hz (40 μ T, for 1 hr)¹⁰³, which was explained by the oxidative stress-radical pair mechanism. ELFs can provoke long-term genotoxic effects as it was shown in a study with rats exposed to 50 Hz (0.97 mT, 3 hrs/day) for 50 and 100 days. In particular, rat plasma showed an exposure time-correlated increase in damaged DNA (8-hydroxy-2'-deoxyguanosine formation) by 45% and 53%, respectively, suggesting the involvement of the oxidative stress mechanism via ELF-induced prolongation of free radical lifetime¹³⁰.

SMF exposure-associated DNA damage was observed in *Drosophila melanogaster* larvae (2- to 3-day old) exposed to a continuous magnetic field (5 T, for 24 hrs), where a significant enhancement of somatic recombination frequency was shown. This effect was suppressed by supplement of vitamin E and suggests that it is ROS/RNS-induced and exerted possibly by prolonging the lifetime of the involved free radicals¹³¹. SMF's also induced apoptosis in exposed (to 128 mT, for 10 days, 1 hr/day) female rats, which resulted in a 30% decrease of thymus relative weight¹¹⁸.

RF effects: In two studies with rats exposed to 2450 MHz (1.2 W/kg SAR, for 2 hrs), pulsed (2 μ s width, 500 pulses/s) or continuous, a substantial increase in DNA single-strand breaks was found in brain cells at 4-hr post-exposure^{132,133}. In view of the fact that DNA damage is mainly done by the ROS formed via the Haber-Weiss/Fenton reaction¹²⁵, the outcome from these studies can be attributed to the oxidative stress mechanism.

5. EMFs induce lipid peroxidation via the pair free radical mechanism

Activation of lipid peroxidation processes, irrespective of the inducer, may lead to destructive changes in the cells, which are associated with the accumulation of lipid peroxidation products (e.g. lipid hydroperoxides and aldehydes such as malondialdehyde and 4-hydroxynonenal) that are able to inactivate membrane enzymes, disturb protein-lipid interactions in membranes, form intermolecular cross-links, change viscosity of the lipid fraction, and prevent formation of enzyme-substrate complex¹⁶.

Free radical electron spin and EMF effects in biological systems are the privilege of membrane phospholipids¹³⁴, mainly because their peroxidation develops as a sequence of reactions involving free radicals¹⁶. The main chemical transformations characterizing the magneto-sensitive stages and changes in lipid peroxidation, resulting to the formation of the toxic malondialdehyde (MDA) accumulation, are described by the following reaction scheme¹³⁵:

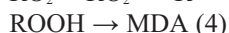
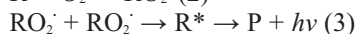
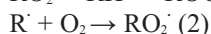

Acceleration of free radical generation in the presence of EMFs should lead to an increase in accumulation of lipid hydroperoxides (ROOH) and MDA. This was experimentally confirmed within the temperature interval of 20-25°C¹³⁵. Competition for RO_2^{\cdot} in equations (1) and (3) depends on the initial spin state of generated radical pair (RO_2^{\cdot} , RO_2^{\cdot}) and the way of disproportionation of radicals. At the initial T state, EMFs accelerate recombination, i.e., inducing $T_{+1,0}$ -S-transitions. At the initial S-state, the sequence of events is reversed. In the last case, EMFs induce S- $T_{+1,0}$ -transitions. Temperature-dependent structural reconstructions are determined by changes in the spatial arrangement of long chains of fatty acids and polar groups contained in phospholipids. Apparently, this determines the mobility of RO_2^{\cdot} and consequently, the lifespan of the excited states and free radical pairs. Lipid peroxidation induced by EMF exposure has been documented by studies on man and various experimental systems including plants.

ELF/SMF effects: In steel workers working either from 3-10 years or more than 10 years at processing shops in the presence of a heater where they were exposed to 50 Hz (1.3 mT), lipid peroxidation was increased by 28% or 56%, respectively, and this effect was associated with the release of copper (and its participation to the Haber-Weiss/Fenton reaction mechanism¹⁶) because of a concomitant ceruloplasmin decrease by 41% or 54%, respectively⁹³.

Exposure of adult guinea pig to intermittent 50 Hz (for 4 days, 2 hrs on/2 hrs off/2 hrs on) resulted in increased plasma lipid peroxidation by 340%¹³⁶. This effect has been previously documented by Seyhan and Canseven (2006) in a cumulative report on studies with guinea pigs exposed to 50 Hz (1-3 mT, for 5 days, 4 or 8 hr/day), where lipid peroxidation increased in kidney (mainly after 4-hr exposure up to 2 mT) in response to ELF-induced increased oxidative stress¹³⁷. Lipid peroxidation levels were also increased in murine squamous cell carcinoma line (AT478) exposed to 50 Hz, and this effect was abolished after combined treatment with the natural antioxidant melatonin and ELF exposure¹³⁸. Similar effect was observed in 3T3-L1 preadipocytes (from murine 3T3 fibroblasts) exposed to 180-195 Hz (120 μT , for 2 days, 36 min/day), where lipid peroxidation in the culture media increased by 22% after 24-hr exposure, and decreased to the control level after 48-hr exposure⁹. In two studies with rats fed/not fed with ZnSO_4 and exposed to 50 Hz (at 5 μT , for 6 months, 5 min/day), lipid peroxidation in plasma and brain tissue was increased by 64% and 120%, respectively¹³⁹, and also increased in plasma, testicle and kidney,¹⁴⁰ while Zn administration caused a significant decrease of lipid peroxidation in all tissues. Given the known physiological function of Zn as antioxidant and metal constituent of the antioxidant enzyme CuZnSOD^{16,141}, these

oxidative effects can be explained by the RF-induced oxidative stress mechanism. In another study with rats exposed to 50 Hz (0.97 mT, 3 hrs/day) for 50 and 100 days plasma showed an exposure time-correlated increase of lipid peroxidation (by 35% and 65%, respectively)¹³⁰. The same phenomenon was observed in rats exposed to 50 Hz (0.018 T, for 20 days, 2 hrs/day), where lipid peroxidation in female/male rat liver and kidney tissue was increased by 88%/287% and 51%/49%, respectively. In contrast, rats exposed to SMF (0.49 T, nonlinear gradient 0-2 T/m, for the same period) showed no significant alterations in the liver and kidney lipid peroxidation levels in comparison with control groups¹⁴².

In terms of increased lipid peroxidation induced by SMFs, this was shown in a study with mice (adult male Swiss BALB/c) exposed to gradient SMF (-2.9 to +2.9 μ T) or to 50 Hz (1.4 mT), both exposure types for the same period of 30 days. Both fields showed a similar trend of action, with lipid peroxidation levels in the liver being significantly increased ~40%¹⁴³. In another study with rat peripheral blood lymphocytes pre-treated with FeCl₂, lipid peroxidation increased by 152% and this effect was further amplified by an extra 23% when the cells were exposed simultaneously to FeCl₂ and SMF (7 mT, for 3 hrs) apparently via the Haber-Weiss/Fenton reaction mechanism⁹⁹.

RF effects: In a study with volunteers (adult males 20-25 years old) exposed for 4 hrs to 900 MHz (by a cellular phone Ericsson GH 688, placed in their pocket in standby mode with the keypad of the phone facing the body -no SAR value was reported) their blood plasma lipid peroxidation was increased by 11%¹⁴⁴. Increased lipid peroxidation was also documented in human blood platelets exposed to cell phone RF 900 MHz for up to 7 min¹⁴⁵.

Lipid peroxidation induced by RF used by mobile phones and WiFi (WLAN) has been documented in many studies using rats. In a study with rats exposed to GSM 900 MHz continuous wave (1.04 mW/cm², 30 min/day for 10 days) lipid peroxidation in kidney increased by 83%. This effect was attributed to RF-induced oxidative stress since it was reversed by the administration of the free radical scavenger melatonin to the rats before RF exposure¹⁴⁶. In rats also exposed to GSM 900 MHz (from a mobile phone placed approx. 10 cm away from the rats, in the standby position and called intermittently for 4 weeks, 10 min 4 times/day), cornea and lens exhibited an increase in lipid peroxidation (860% and 128%, respectively), which was substantially reduced by antioxidant vitamin C supplementation (before RF exposure), suggesting again that mobile phone RF induces oxidative stress¹⁴⁷. Similarly, in rats exposed to 890-915 MHz (modulation frequency 217 Hz, SAR 0.52 W/Kg, averaged power 250 mW, for 1 month, 20 min/day) lipid peroxidation increased by 52% in brain tissue (without any visual histological alteration)¹⁴⁸, while in rats exposed to GSM 900 MHz (analog phone continuous wave, with brain SAR 2 W/kg and average whole body SAR 0.25 W/kg, for 1 week, 1 hr/day) lipid peroxidation increased by 28% in brain tissue, although it developed histopathological changes. Both effects were attributed to RF-induced oxidative stress since administration of the antioxidant *Ginkgo biloba* extract reversed all these effects to the control levels¹⁴⁹. Same effects were documented in a study with guinea pigs exposed to a cellular phone RF 890-915 MHz [pulse rate 217 Hz, maximum peak power 2 W, SAR 0.95 W/kg, for 30 days, 12 hrs (11 hrs and 45 min in stand-by and 15 min in speaking mode)/day], where lipid peroxidation in brain tissue and blood increased by 13%, and 44%, respectively¹⁵⁰. Significant lipid damage was also reported in a series of studies with rats exposed to 900 MHz (by a cell phone-simulating half wave dipole antenna, pulse modulated with 217 Hz repetition cycle, 2 W peak output power and 1.04

mW/cm² power density, with SAR varying between 0.016 for whole body and 4 W/kg for the head, for 10 days to 3 months, 30 min/day). Lipid peroxidation in retina and kidney increased by 43% and 47% after 10-day and 3-month exposure, respectively^{151, 152}, and increased also in myocardial tissue (after 10 day exposure)¹⁵³. This effect was attributed to increased oxidative stress since it was reversed (to the control level) by the administration of the antioxidants melatonin or caffeic acid phenethyl ester. The oxidative stress mechanism is also involved in the increased lipid peroxidation (by 50%) observed in the plasma of rats exposed to 945 MHz (pulse modulated at 217 Hz, SAR 11.3 mW/Kg at power density 3.67 W/m², for 8 days 7 hrs/day)¹⁵⁴. Increased lipid peroxidation was also documented in two studies with rats exposed to 2450 MHz (continuous-wave, with SAR 9.2 W/kg at an incident power density 40 mW/cm², for 15 min). Heart tissue damage 6 days after exposure was assessed as accumulation of the lipid peroxidation products malondialdehyde (MDA, lipid oxidation end product) and lipofuscins (complexes of oxidized lipids and proteins), which increased by 87% and 43%, respectively¹⁵⁵. Moreover, MDA in rat liver 2, 4 and 6 days after exposure increased to 1.3, 1.5, and 1.7 fold, respectively¹⁵⁶. These effects were partially reversed by the administration of the antioxidant green tea catechin, which supports the hypothesis that RF effects are exerted via the oxidative stress mechanism. Similarly, in rats exposed to GSM 900 MHz (SAR 1.2 W/Kg, for 4 weeks, with cellular phone being in the stand-by position and called intermittently 4 times/day for 10 min in on position), erythrocyte lipid peroxidation increased by 24%, and this was associated with oxidative stress because it was mostly reversed by supplementation of rats with the natural antioxidant vitamin C before RF exposure¹⁵⁷. In another study, rats exposed to cellular phone-modulated 900 MHz EMF exhibited increase of liver lipid peroxidation, which was decreased by administration of the antioxidant caffeic acid phenethyl ester (an active component of propolis extract), suggesting that EMF-induced oxidative changes in liver were reversed by strengthening the antioxidant defense system¹⁵⁸.

Lipid peroxidation can be induced by RFs even in plant tissue. This was shown by a study on Duckweed (*Lemna minor* L.) exposed from 400 MHz to 300 GHz (both RFs at field strengths of 10, 23, 41 and 120 V/m, for 2 and 4 hrs). At 400 MHz, lipid peroxidation increased by 16% and 33% at 23 and 120 V/m, respectively, while the other exposure treatments did not have an effect. However, at RF 900 MHz almost all exposure treatments significantly increased lipid peroxidation between 13% and 23%, suggesting that 900 MHz preferably induces lipid damage in plant tissue¹⁵⁹.

6. EMFs increase oxidative stress by direct change of the levels of ROS/RNS and of oxidant enzymes

Lipid peroxidation, DNA damage and alteration of antioxidant and metabolic enzyme activities are well known effects of ROS/RNS on cell metabolism¹⁶. It has been experimentally shown that ROS/RNS production can be induced by a combination of EMF exposure and stimulation/amplification by internal and external factors (see sub-section 3., p. 86). This sub-section presents experimental evidence that EMFs alone can induce production of ROS/RNS, possibly as result of the increased activity of certain oxidant enzymes.

ELF/pulsed magnetic field (MF) effects: In a study with human umbilical cord blood-derived monocytes and human monocytic Mono Mac 6 cells exposed to 50 Hz (1 mT, for 45 min) there was an increase (1.2 and 1.5 fold, respectively) of ROS/RNS

(measured non-specifically by dihydrorhodamine 123 fluorescence) and equal increase (1.4 fold) of superoxide radical (measured non-specifically by nitroblue tetrazolium chloride). This increase concurred with activation of the superoxide radical-producing enzyme NADH oxidase¹²⁷. Cellular activation processes were also observed in another study with murine macrophages and their precursor cells. When exposed to 50 Hz (1 mT, for 45 min to 24 hrs) ROS/RNS production (measured by dihydrorhodamine 123) increased by 25%. In 50 Hz-exposed promonocytes an increase (by 25%) was also observed for superoxide radical (using the non-specific nitroblue tetrazolium chloride assay), and this was attributed to NADH oxidase activation. Furthermore, in differentiated macrophages, a significant increase (up to 33%) of superoxide radical production was observed after ELF exposure¹⁶⁰. Post-exposure cell activation was observed in a study with HL-60 cells, Rat-1 fibroblasts and WI-38 diploid fibroblasts exposed to 50 Hz (0.50, 0.75 and 1.0 mT, for 3-72 hrs). There was a ~18% increase in ROS levels (non-specifically measured by dihydrofluorescein diacetate fluorescence) as early as 3 hrs after exposure to ELF, and this increase persisted after 24-hr exposure¹¹².

ROS production by ELFs, independent of cell stimulation, was shown in the following studies: Phorbol 12-myristate-13-acetate (PMA)-stimulated mouse bone marrow-derived macrophages exposed to 50 Hz (0.5-1.5 mT, for 45 min) showed the same as the non-stimulated cells increase in phagocytic activity (36.3%) and superoxide radical production (33%, assessed by the nitro blue tetrazolium dye)¹²⁶. In another study, ELFs (50 Hz, 0.05-1 mT, for 45 min to 48 hrs) contributed to a general activation of mouse macrophages (lipopolysaccharide-activated or not), resulting in changes of numerous immunological reactions such as in increased ROS formation (1.4 fold, as measured with dihydrorhodamine 123 fluorescence), in an enhanced (by 1.6 fold) phagocytic activity, and in an increased interleukin-1 β release (up to 12.3 fold)¹⁶¹.

ELFs and pulsed DC MFs induce also RNS production, as it was shown in a study with adult guinea pig exposed to continuous or intermittent 50 Hz (1.5 mT, continuous 4 hrs/day, or intermittent 2 hrs on/2 hrs off/2 hrs on, for 4 days). Intermittent exposure caused increased NO \cdot levels (by 58%), while continuous exposure caused increase in both plasma myeloperoxidase (MPO) activity (by 45%) and NO \cdot levels (by 77%). Moreover, MPO in blood increased by 30% at intermittent exposure, and decreased in liver by 25% at both ELF exposure modes¹³⁶. It should be noted that MPO catalyzes the oxidation of H₂O₂ to the very potent oxidant product hypochlorous acid. Analogous results have been reported by Seyhan and Canseven (2006) in a review on studies with guinea pigs exposed to 50 Hz (1-3 mT, for 5 days, 4 or 8 hr/day), where NO \cdot levels and MPO activity were increased in lung and kidney, respectively, possibly in response to ELF-induced increased oxidative stress¹³⁷. In a study using pulsed DC MF (0.1 mT, for 1 hr), even crude solutions of rat cerebellum nitric oxide synthase (the enzyme that forms the free radical NO \cdot from L-arginine and NADPH; see sub-section 7.1) exhibited 11.2% increase in activity⁴⁶. Increased concentrations of NO \cdot were also observed at much higher ELF exposure levels such as those attained by a magnetic resonance imaging (MRI) apparatus. In a study with 33 male volunteers (aged 18-26 years old) exposed to a 1.5 T static magnetic field for 30 min (against a control group aged 19-26 years old) their NO levels were increased by 18%¹⁶².

RF effects: These have been shown by the following studies associating RF exposure with the RNS component NO \cdot and with ROS producing and oxidant enzymes. Rabbits (adult male albino, New Zealand type) were exposed to GSM 900 MHz (by a commercially available cellular telephone emitting 2 W peak power, average power density 0.02

mW/cm², for 7 days, 30 min/day). Serum NO⁻ levels decreased by 60% in the exposed animals compared to the sham group, suggesting a probable role of RNS in the RF-induced adverse effect¹⁶³. However, in rats also exposed to GSM 900 MHz (for RF exposure details see sub-section 5., p. 90) brain tissue NO⁻ levels and the activities of xanthine oxidase (O₂⁻-producing enzyme) and adenosine deaminase (ADA) increased by 106%, 71% and 39%, respectively. ADA, in particular, is responsible for the deamination of toxic adenosine to the physiologically less active inosine. ADA activity affects also brain function because adenosine can act as a neuromodulator and/or neurotransmitter in CNS and some peripheral systems¹⁶⁴. These effects were attributed to RF-induced oxidative stress since they were reversed (to the control levels) by the antioxidant *Ginkgo biloba* extract¹⁴⁹. In rats also exposed to 900 MHz (for RF exposure details see sub-section 7.5) NO increased by 210% and 155% in the retina and kidney, respectively^{151,152}, as well as in myocardial tissue¹⁵³, and this effect was related to RF-induced increased oxidative stress since it was reversed by administration of either one of the antioxidants melatonin and caffeic acid phenethyl ester. In another study, GSM 1800 MHz exposure [at modulations GSM-non DTX (speaking only), GSM-DTX (hearing only), GSM-Talk (34% speaking and 66% hearing)] of human Mono Mac 6 and K562 cells (at SAR 0.5, 1.0, 1.5 and 2.0 W/kg) induced a significant increase in O₂⁻ and ROS production when compared to sham and/or incubator conditions¹⁶⁵. ROS are produced at even higher RFs. Yeast cultures exposed for 20 min to a 9.71 GHz pulsed electromagnetic field (at SAR 0.5 W/kg) exhibited 20 and 50% increase of free radical production in the intra cellular compartment¹⁶⁶.

Increased ROS production via RF exposure and its relation to ROS -inducing oxidant enzymes has been documented in a study with rats exposed to 2450 MHz (for RF exposure details see sub-section 5., p. 90). Six days after exposure heart tissue exhibited an increase (by 35%) in superoxide radical production (measured *in vitro* in heart homogenates prepared after RF exposure by the SOD-inhibited reduction of ferricytochrome *c*), which slightly decreased (to 30%) after administration of the antioxidant green tea catechin. Moreover, cytochrome *P450* level was increased by 85% (and lowered to 62% in the presence of catechin), with concomitant increase of the NADPH-cytochrome *P450* reductase activity by 29%/22% (-/+ catechin, respectively)¹⁵⁵. It has been already established that ROS can be produced by cytochrome *P450* (being also a biological damage indicator) as well as by 'futile cycling'⁵⁵ e.g. of other cytochromes *P450*¹⁶⁷. In another study with rats exposed to cellular phone RF 900 MHz (for exposure details see sub-section 5., p. 90) XO activity in erythrocytes significantly increased by 50%. However, XO and ADA activities in the kidney/heart tissue decreased by 10%/22% and 22%/20%, respectively. These results were mostly reversed to the control levels by supplementation of the antioxidant vitamin C, which, again, is a strong indication of ROS involvement. Similarly, Sprague-Dawley rats exposed to cellular phone-modulated 900 MHz EMF ± the antioxidant caffeic acid phenethyl ester (CAPE) exhibited increase of XO activity, which was decreased by CAPE administration. It was concluded that CAPE may prevent the 900 MHz EMF-induced oxidative changes in liver by strengthening the antioxidant defense system via ROS reduction¹⁵⁸.

RFs can induce ROS increase even in plants as it was shown in a study where duckweed (*Lemna minor* L.) was exposed from 400 MHz to 300 GHz (for RF exposure details see sub-section 5., p. 90). At 400 MHz H₂O₂ content in duckweed increased ~30% only when exposed to 23 and 120 V/m, while at 900 MHz H₂O₂ content increased between 12% and 34% almost at all exposure treatments, and it was concluded that H₂O₂ and oxidative stress are mostly induced at 900 MHz in plant tissue¹⁵⁹.

7. *EMFs affect the antioxidant defense (enzymic/non-enzymic) and the activity of enzymes associated with biological damage/disease/metabolism*

EMFs can change the activity of the main antioxidant enzymes (SOD, GPx, CAT) and make cells more vulnerable to ROS/RNS attack. They can even affect (decrease/increase) the activity of enzymes that serve as indicators of perturbed metabolism and disease.

EMFs (ELF and RF) can induce protein oxidation: The decrease in enzyme activity, besides being indirectly controlled by gene expression¹²¹, can be due to degradation of oxidized proteins possibly resulting e.g. by EMF-induced free radical oxidative attack on crucial for activity protein domains. This is supported by the finding that in rats (Wistar-Albino female, 8 week-old) exposed to 50 Hz (1 mT, for 45 days, 4 hrs/day) a substantial increase (by 77%) of 3-nitrotyrosine was observed in female liver¹⁶⁸, suggesting a deteriorative effect on cellular proteins due to possible formation of the protein oxidant RNS component peroxynitrite (from $O_2^{\cdot-}$ and NO). For example, nitrotyrosine accumulation has been correlated with many diseases such as the prototypical autoimmune disease systemic lupus erythematosus¹⁶⁹, Alzheimer's disease and aging¹⁷⁰. Protein damage was also reported in rats exposed to 2450 MHz (for exposure details see sub-section 5., p. 90), where their heart tissue exhibited increase of protein carbonyls and lipofuscins (i.e. oxidized protein-lipid complexes) by 10% and 43%, respectively¹⁵⁵. In another study with guinea pigs exposed to power frequency electric (E) field (50 Hz, 12 kV/m, 7 days/8 h/day), no statistically significant changes occurred in protein carbonyl content, advanced oxidation protein products and 3-nitrotyrosine levels with respect to the control group. However, liver hydroxyproline level was significantly diminished in the E field exposure group compared to the control and protein carbonyl content, and hepatic hydroxyproline and 3-nitrotyrosine levels changed significantly in antioxidant N-acetyl-L-cysteine-administrated groups¹⁷¹.

ELF/SMF effects: These have been documented by studies on man and other organisms including plants. In steel workers (working at processing shops in the presence of a heater were exposed to 50 Hz, 1.3 mT) those working less than 3 years exhibited no significant changes in the activity of SOD and GPx in red blood cells. However, the activity of both antioxidant enzymes decreased by 13% in those working from 3 to 10 years, and also by 19% and 12%, respectively, in those working more than 10 years, while CAT activity was increased by 19% and 32%, respectively. Furthermore, plasma GPx showed a non-significant tendency to decrease. These effects were attributed to oxidative stress because they were accompanied by an increase of lipid peroxidation (by 28% and 56% for workers working from 3-10 years and more than 10 years, respectively)⁹³. In another study of the same research group with rats, female/male liver and kidney tissue in animals exposed to 50 Hz (0.018 T, for 20 days, 2 hrs/day) showed an increase in the activity of SOD (by 30%/67% and 62%/47%, respectively), CAT (11%/68% and 59%/85%, respectively) and GPx (17/5% and 30/4%, respectively). However, when the rats were exposed to SMF (0.49 T, non-linear gradient 0–2 T/m) for the same period, they showed no significant alterations in the activities of the antioxidant enzymes in either organ¹⁴². The combination of 60 Hz exposure (1.2 mT, for 3 hrs) and treatment of mouse brain homogenates with the lipid hydroperoxide analogue *tert*-butyl-hydroperoxide increased SOD activity by ~50% in response to increased oxidative stress¹⁰¹.

ELF-induced alteration of the enzymic antioxidant defense has been documented in other studies as well. In a study with 3T3-L1 preadipocytes (from murine 3T3 fibrob-

lasts) exposed to 180-195 Hz (120 μ T, for 2 days 36 min/day), MnSOD and Cu/ZnSOD decreased by 70% and 20%, respectively, after 24-hr exposure, and CAT increased by 45%, while no change in activity was observed in GSSG-reductase. Exposure for 48 hrs reduced significantly all antioxidant enzymes except of GSSG-reductase, without affecting the proliferation rate of 3T3-L1 cells⁹. The unchanged activity of the glutathione (GSH)-regenerating enzyme GSSG-reductase suggests that glutathione (GSH) is not involved in the antioxidant defense of these cells. In another study by the same lab, the activity of MnSOD and Cu/ZnSOD but not GPx in murine squamous cell carcinoma line (AT478) was increased upon 50 Hz exposure, and this effect was in response to ELF-induced increase of oxidative stress since it was reversed after a combined treatment with antioxidant melatonin before ELF exposure¹³⁸. Moreover, ELF-MF exposure (sinusoidal 50 Hz, 0.1 mT for 10 days) of female Sprague–Dawley rats significantly affected antioxidant capability both in young and aged animals, although in opposite ways. Exposed young individuals enhanced their neurotrophic signalling and anti-oxidative enzymatic defence (SOD, GPx, CAT) against a possible ELF-MF-mediated increase in oxygen radical species, while aged rats underwent a significant decrease in the major antioxidant enzymatic activities (CAT, GR, GPx), suggesting that exposure to ELF-MFs may act as a risk factor for the occurrence of oxidative stress-based nervous system pathologies associated with ageing¹⁷².

ELFs and SMFs can cause even extensive disturbance in metabolism as it was shown by the following study using mice (Swiss BALB/c, adult male) exposed either to SMF (gradient -2.9 to +2.9 μ T) or to 50 Hz (1.4 mT) for 30 days. Both fields showed similar trend of action; gradual body weight loss and significant decrease in serum glucose concentration, in alkaline phosphatase activity and in total protein levels (possibly resulting in decrease of the levels of important for antioxidant defense metabolic enzymes); significant increase in lactate dehydrogenase activity in serum and liver, paralleled by significant activity elevation in hepatic γ -glutamyl transferase (e.g. related to the infiltration of fat in the liver and to hypertension¹⁷³); significant increase in GSH-S-transferase (the enzyme that neutralizes oxidative stress-inducing toxic xenobiotics¹⁶) and decrease in the antioxidant thiol GSH in the liver. Furthermore, a significant decrease in the counts of monocytes, platelets, peripheral lymphocytes as well as splenic total T- and B-lymphocytes levels was observed, and the granulocyte percentage was significantly increased. These results strongly suggest a causative relation between SMF/ELF exposure and increased oxidative stress via redox balance alteration leading to extensive physiological disturbances¹⁴³. Significant perturbation of the main antioxidant thiol GSH was also shown in guinea pigs (a) in a series of studies by Seyhan and Canseven (2006) after exposure to 50 Hz (1-3 mT, for 5 days, 4 or 8 hr/day), where they reported an increase of GSH in lung and kidney¹³⁷, and (b) in another study after exposure to continuous/intermittent 50 Hz (1.5 mT, continuous 4 hrs/day, or intermittent 2 hrs on/2 hrs off/2 hrs on, for 4 days), where both modes of ELF exposure resulted in a slight decrease of GSH in blood and intermittent exposure caused GSH decrease in brain by 35%¹³⁶. These adaptive responses were possibly due to ELF-induced increased oxidative stress. Decrease of GSH upon ELF exposure was also shown in two studies with rats fed/not fed with ZnSO₄ and exposed to 50 Hz (at 5 μ T, for 6 months, 5 min/day). GSH concentration decreased in erythrocytes and brain by 40%¹³⁹, as well as in testicle and kidney¹⁴⁰. Since GSH levels were elevated to the control by the administration of Zn, these effects can be explained by the RF-induced oxidative stress mechanism given the antioxidant function of Zn¹⁴¹ and its participation in the active center of the important antioxidant enzyme CuZnSOD¹⁶.

RF effects: Antioxidant defense can be altered by RFs in man and in various experimental systems, including plants. In the previously mentioned study (sub-section 5., p. 90) with the 12 adult male volunteers exposed to 900 MHz by a cellular phone, erythrocyte antioxidant enzymes SOD and GPx decreased (by 7% after 4 hrs and by 9% after 1 hr exposure, respectively), while the levels of CAT were unchanged¹⁴⁴. Decreased SOD activity was also observed in human blood platelets exposed to cell phone RF 900 MHz for up to 7 min¹⁴⁵.

Antioxidant defense perturbation has been observed in many studies using RFs emitted by mobile phones. In rats fed/not fed with vitamin C and exposed to GSM 900 MHz (from a mobile phone, see exposure conditions in sub-section 5., p. 90) cornea CAT activity was increased by 220% while SOD was decreased by 50%. However, lens CAT and SOD activity increased by 33 and 16%, respectively, while cornea/lens GPx activity was not significantly changed. Vitamin C supplementation reduced rat eye impairments to the control levels, suggesting that the alteration of the enzymic antioxidant defense was in response to RF-induced oxidative stress¹⁴⁷. Changes in antioxidant defense were also seen in a study with rats exposed to cellular phone 900 MHz (exposure details in sub-section 5., p. 90), where erythrocyte GPx activity increased by 12% and kidney tissue CAT activity increased by 29%. These effects were mostly reversed by administration of vitamin C¹⁵⁷ and for this reason they can be attributed to antioxidant defense adaptation in response to RF-induced increase in ROS production (possibly the CAT and GPx substrate H₂O₂¹⁶). Same conclusions were drawn by another study with rats exposed to GSM 900 MHz (exposure details in sub-section 5., p. 90), where brain tissue SOD activity increased by 12% and returned to normal upon administration of the antioxidant *Ginkgo biloba* extract, while that of GPx remained unchanged¹⁴⁹. The oxidant effect of mobile phone RFs on antioxidant defense was also shown in a study with rabbits exposed to 900 MHz (by a commercial cellular telephone, see exposure details in sub-section 6., p. 93), where serum SOD activity increased by 10%¹⁶³, and in another study with rats exposed to 945 MHz (see exposure details in sub-section 5., p. 90), where erythrocyte SOD activity increased by 41% and total blood GSH decreased by 59%¹⁵⁴. In another study, rats exposed to cellular phone-modulated 900 MHz EMF exhibited increase of CAT activity, which was decreased by administration of the antioxidant caffeic acid phenethyl ester¹⁵⁸.

The alteration of the non-enzymic antioxidant defense by mobile phone RFs alter has been shown also in a study on guinea pigs exposed to RF 890-915 MHz (exposure details in sub-section 5., p. 90). The levels of the blood antioxidant vitamins A, D₃ and E, and the activity of CAT were all increased by 44%, 127%, 45%, 42%, and 13%, respectively, and they concurred by 18% decrease of GSH. Moreover, GSH and CAT in brain tissue were both decreased by 18% and 29%, respectively, while the concentration of vitamins A, E and D₃ remained unchanged¹⁵⁰. Similar non-enzymic defense changes were reported in another study with rats exposed to mobile phone GSM 900 MHz (whole body SAR of 0.25 W/Kg intermittently for 4 days, 15 min/day, or acutely for 1 hr), where there was a decrease in the plasma vitamins C (by 47% or 59.8%, respectively), E (by 33% or 65.7%, respectively) and A (by 44.4% or 46.8%, respectively). This was accompanied by a decrease in the main plasma GSH (by 19.8% and 35.3%, respectively), as well as in the antioxidant enzymes CAT (42% or 52%) and SOD (19.5% or 22%)¹⁷⁴. These results, besides their direct relation to the oxidative stress mechanism, indicate that the effects of acute mobile phone RF exposure on rat's antioxidant status are significantly higher and thus more hazardous than those of the intermittent exposure.

Similar conclusions were derived by a series of studies on rats exposed to 900 MHz (exposure details in sub-section 5., p. 90), which concurred with activity changes in enzymes-indicators of biological damage/disease. The activities of SOD, CAT and GPx in retina were reduced by 30%, 20% and 22.5%, respectively, after 60-day exposure¹⁵¹. The same enzymes showed exposure period dependent activity decreases in kidney (15%/25%, 0%/26% and 25%/18,5%, for 10-day/3-month exposure, respectively)^{152,175}, which were exhibited also in myocardial tissue after 10 day exposure¹⁵³. Increased activity (by 250%) was observed in the urinary *N*-acetyl- β -D-glucosaminidase (marker of oxidative stress-induced renal tubular damage) after 10-day exposure¹⁷⁵, which further increased to 350% after long-term (3 month) exposure¹⁵². All these effects were oxidative stress-dependent since they were reversed to the control level by the administration of the antioxidants melatonin and caffeic acid phenethyl ester. Similar effects were observed in a study with rats exposed to GSM 900 MHz (continuous wave, at 1.04 mW/cm², for 10 days, 30 min/day), where their kidney showed a 360% activity increase in urine *N*-acetyl- β -D-glucosaminidase and decrease of SOD, CAT and GPx (by 25%, 25% and 19%, respectively). Again, these effects demonstrated RF induction of oxidative stress since melatonin supplementation reversed them and ameliorated oxidative tissue injury in rat kidney via its free radical scavenging and antioxidant properties¹⁴⁶.

In another study using even higher RFs such as those used by WiFi (WLAN), rats (Wistar) exposed to 2450 MHz (exposure setup in sub-section 3, p. 86) showed a significant increase in ornithine decarboxylase (by 247%) activity and a decrease (by 57%) in the calcium-dependent protein kinase activity, both enzymes being associated with ROS/RNS controlled¹²¹, tumor-associated cell proliferation and differentiation¹²⁰. RF exposure at 2450 MHz affects antioxidant defense by inducing oxidative stress, as it has been documented in two studies with rats (for exposure details see sub-section 5., p. 90). Six days after exposure, heart tissue SOD activity decreased by 34%/25% at \pm antioxidant catechin supplementation, respectively, and so did GPx activity (28%/0%, respectively)¹⁵⁵. Moreover, SOD activity in liver decreased on the 4th day after exposure, and increased to the control level by catechin supplementation on the 8th day. Furthermore, liver GPx activity decreased on the 8th day and increased to the control level on the 16th day, an effect also attained by catechin supplementation on the 6th day. In addition, SOD and GPX activities decrease concurred with decrease in expression of the corresponding genes, which were cancelled by catechin supplementation¹⁵⁶.

Mobile phone emission has been shown to interfere with electron transfer processes that take place during the enzymic reactions of lactoperoxidase, ascorbate oxidase and laccase. The biochemical reactions catalyzed by these enzymes proceed by generating free radical intermediates, which are paramagnetic species sensitive to electromagnetic fields. Particularly, RF's emitted by a dual band mobile phone (915-1822 MHz, in receiving mode at electric field emitted intensity of 3 V m⁻¹) altered both conformational and configurational features of the steady-state transition complexes formed by these enzymes⁴⁹.

Antioxidant enzymic defense can be perturbed even in RF-exposed plants as it was shown in a study with duckweed (*Lemna minor* L.) exposed from 400 MHz to 300 GHz (for exposure details see sub-section 5., p. 90). At 400 MHz, CAT activity was increased after most exposure treatments while both activities of pyrogallol peroxidase (PPX) and ascorbate peroxidase (APX) did not change. Exceptions were the reduced PPX and APX activities after longer exposure at 23 V/m, and the increased PPX activity after exposure at 10 and 120 V/m. By contrast, at 900 MHz almost all exposure treatments decreased

mostly PPX activity and did not affect CAT activity. Exceptions were exposures to a modulated field and to the field of 120 V/m, which increased both PPX and CAT activities. At this RF, APX activity was significantly decreased after exposure at 10 V/m and 23 V/m, but it increased after a shorter exposure at 23 V/m. It was concluded that perturbation in the activities of the plant antioxidant enzymes occurs mostly at 900 MHz¹⁵⁹.

Oxidative stress induces disease in man

Living systems and man maintain a balanced reducing state within their cells preserved by antioxidant and reducing power forming enzymes through a constant input of metabolic energy. This balance is upset under increased levels of oxygen free radicals (high oxidative stress), depletes cells from ATP and prevents their controlled (apoptotic) death, thus causing cell necrosis and disease^{176,177}. Most of the oxygen-derived species are produced at low levels by normal aerobic metabolic processes, and the damage they cause to cells is continuously repaired. Normally, regulated levels of ROS/RNS can be metabolically beneficial, since e.g. they contribute to the immunological defense by attacking and killing various pathogens. In addition, they are involved in transduction signaling pathways, and in order for these redox-signaling rôles to be exercised a balance must exist between reactive oxygen production and consumption¹⁶. Therefore, disturbance of ROS/RNS normal levels, as in the case of EMF exposure, could cause cascades of biochemical reactions that may induce amplification of the primary response and result in disease in man (fig. 7).

The numerous studies already presented above show beyond any doubt that EMF exposure causes perturbation of normal redox state and results in a multiplicity of adverse biological effects through the production of various organic/inorganic ROS/RNS (oxygen and nitrogen free radicals, peroxides, hydroperoxides etc) that damage all structural and functional cell components, especially DNA¹²⁴. Besides damaging important biomolecules, which can be mostly repaired, EMFs can cause perturbation of cell/organism antioxidant defense and normal metabolism, with most prominent long term effect the non-repairable DNA damage¹⁷⁸ known to be directly associated with carcinogenesis.

Reviewing the literature on EMF (ELF and RF) effects up to 2004, Simkó and Mattsson proposed that EMFs might be a stimulus to induce an 'activated state' of the cell (such as phagocytosis, signal transduction pathways involving calcium metabolism etc), which then enhances (amplifies) the release of free radicals, leading in turn to genotoxic and other disease-causing biochemical processes¹⁷⁹. They envisage that EMF exposure can cause both acute and chronic effects that are mediated by increased free radical levels via four distinct processes: (1) Direct activation e.g. of macrophages (or other cell types) by short-term exposure to EMF leading to phagocytosis or other cell specific responses and consequently to free radical production; (2) EMF-induced cell activation includes direct stimulation of free radical production; (3) an increase in the lifetime of free radicals by EMF leads to persistently elevated free radical concentrations -in general, reactions in which radicals are involved become more frequent, increasing the possibility of DNA damage; (4) long-term EMF exposure leads to a chronically increased level of free radicals, subsequently causing an inhibition of the effects of the pineal gland antioxidant hormone melatonin. Taken together, these EMF-induced reactions could lead to a higher incidence of DNA damage and therefore to an increased risk of tumour development.

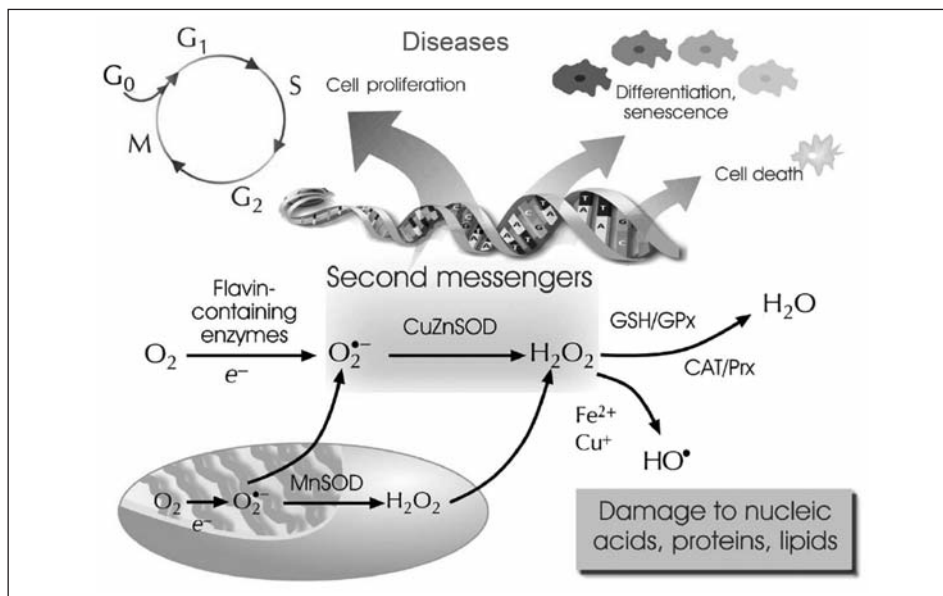

Fig. 7. Cell free radicals are responsible for disease development in man on a multistage level. EMF-induced ROS generated mainly in mitochondria or by various biochemical reactions (catalyzed by flavin-containing enzymes) can cause diseases either by inducing (as second messengers) abnormal cell proliferation and differentiation (e.g. various cancer types) and cell death (e.g. neurodegenerative diseases), or by destroying crucial for cell/organism physiological function biomolecules (e.g. DNA, proteins and lipids via hydroxyl radical attack)

In man, oxidative stress is implicated in the pathophysiology of a wide range of diseases such as multistage carcinogenesis (e.g. brain, breast cancer and cancer-prone diseases), in autoimmune, cardiovascular and neurodegenerative diseases (Parkinson's, Alzheimer's, Lou Gehring's and Huntington's disease, cerebral ischemia), in mitochondrial and respiratory diseases, human reproduction, Down's syndrome, ulcerative colitis, rheumatoid arthritis, inflammatory bowel disease, atherosclerosis, even in aging and HIV infection^{102,180-184}. Numerous epidemiological studies have linked EMF exposure with cancer and oxidative stress^{185,186}. In particular, ELF (classified as "possible human carcinogen" by the International Agency for Research on Cancer) have been linked with childhood leukemia and with increased risk for all cancer and brain tumors in relation with oxidative stress¹⁸⁷⁻¹⁹⁰. EMFs (ELFs and RFs) have also been related to oxidative stress-induced neurodegenerative diseases (as well as with suicide and depressive symptoms)¹⁹¹, and they have been linked to various long/short term diseases especially in people hypersensitive to the electromagnetic pollution¹⁹².

Opinions and implications

Low-level EMFs can interact non-thermally with biological systems primarily by spin-polarized chemical steps that can be enhanced by non-linear biological amplification mechanisms that can be triggered with internal and external factors. Free radicals

occur widely in normal biochemical reactions. Free radicals originate mostly from homolytic geminate singlet reactions. It is only the reactions involving the combinations of free radicals themselves that are EMF-dependent. Two different processes are essential to the reactions of free radicals in solution; spin evolution and diffusion. Biological effects at low EMF strength are more likely to arise in geminate radical pairs due to spin shifting from the S to T state, which would result in an increase of the non-recombined radicals largely due to the possibility of restricted molecular motion in them being more probable within cells. It has been known that an increase in the oxygen centered free-radical concentrations in the body is potentially harmful mainly because free radicals tend to be highly reactive and mostly indiscriminating in their reactions. Tissue free radical interactions with EMFs disturb tissue thresholds which control ensemble or domain functions of populations of cells, cooperatively whispering together in intercellular communication and organized hierarchically at atomic and molecular levels¹⁹³.

There are many experimental lines of evidence towards the existence of an oxidative stress mechanism implicated in the development of non-thermal biological effects by EMF (ELF and RF) and SMF exposure. This evidence strongly suggests the involvement of the free radical pair mechanism on the oxidative stress-inducing effect of EMF and SMF as amplified by various extracellular and intracellular stimulants (fig. 8). This has been shown by indirect evidence that oxygen free radicals are generated in experimental organisms and cells during and/or after exposure to EMFs. Oxygen/nitrogen free radicals uncover their presence by the various biological alterations they cause; serious damage on lipids (lipid peroxidation) and DNA (fragmentation and nicks), decrease in the activity of important enzymes involved in the antioxidant protection of the cell, and alterations in the activity of a variety of other important metabolic enzymes, all of which reflect on the harmful perturbation of the general cell/organism metabolism.

The overemphasized and monotonous argument of scientists supporting the idea of no casual connection between EMF exposure and disease in man is that there is no biochemical mechanism by which such relationship can be established. Based on this argument, then, they discount as experimentally and theoretically inadequate even epidemiological studies showing such association. The EMF-induced oxidative stress mechanism uncovered in the present treaty is based on the unification of sound physical, chemical and biochemical processes with fully supportive experimental evidence. Although it may not be the sole mechanism, the rôle of oxidative stress in explaining the adverse EMF effects on man's health may be central since free radicals are part of the physiology (both normal and abnormal) of organisms, and man. Thus, this mechanism can be extended to all future research including epidemiological studies. For example, in designing epidemiological studies based on this mechanism, parameters affecting the antioxidant defense status of the participants should be accounted for. This mechanism predicts that people with low or disease-compromised antioxidant defense due to various factors (e.g. age, poor diet, iron overload, exposure to oxidative stress-inducing working/living conditions and to various environmental pollutants, etc) are more vulnerable to the harmful effects of EMF exposure.

Until now, the evidence of oxidative stress formation under the influence of EMF's is only indirect because it has been based on the non-specific detection of ROS (free radical plus non-free radical oxidants, see Table 1), on measuring oxidative stress-induced biological effects (e.g. lipid peroxidation, DNA and protein damage, perturbation of enzymic/non-enzymic antioxidant defense), and on the reversal of all these effects by natural and artificial antioxidants (such as melatonin, ROS spin traps etc). In

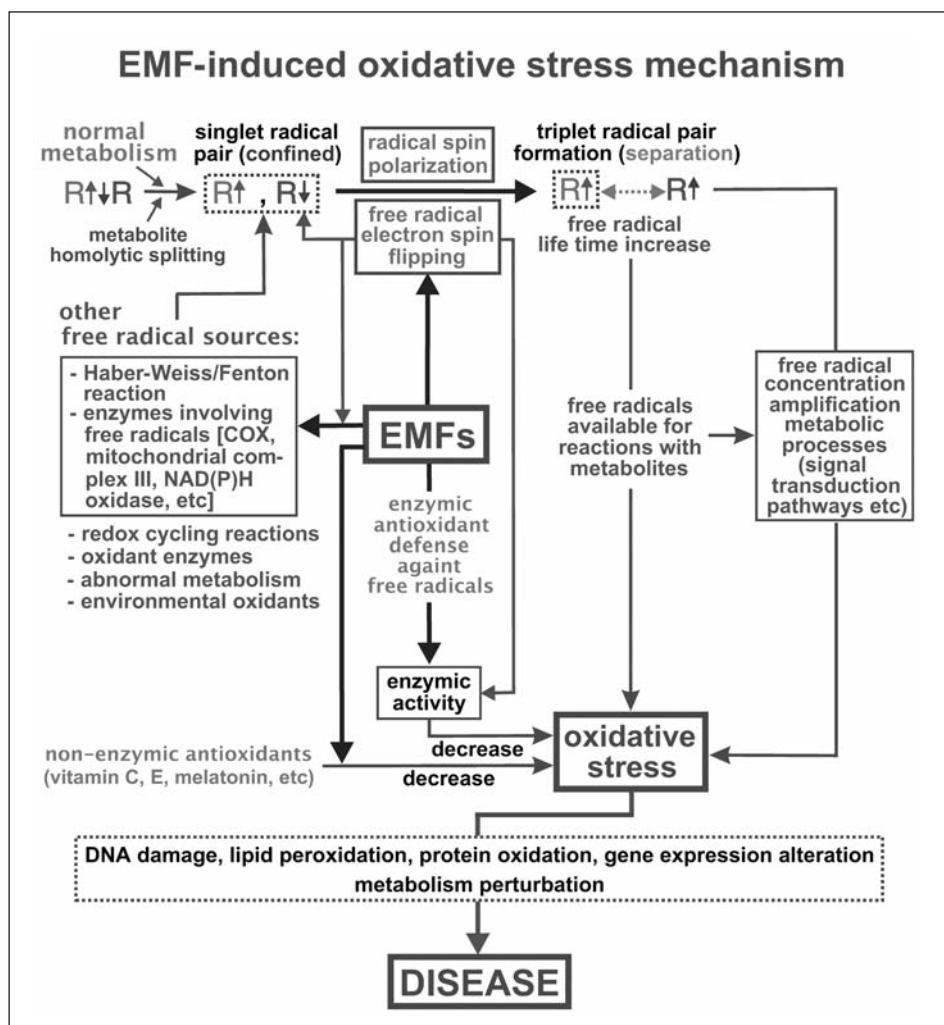

Fig. 8. Diagram of the EMF-induced oxidative stress mechanism. Free radicals are generated by normal metabolism, which involves biochemical homolytic splitting of numerous metabolite molecules, and the formation of singlet free radical pairs. EMFs mostly affect confined free radical pairs; one radical may be immobilized e.g. by attachment to an enzyme surface, with the partner radical able to diffuse around it (or both free radicals may be so attached); or the radical pairs can be localized within a membrane at the time of their creation or immobilized by proteins and DNA. Under these confined conditions and due to magnetic fields from the spin of protons adjacent to free radicals, EMF exposure makes them experience distinct local magnetic fields that can cause electron spin flipping, radical separation and concentration increase (by extending their life time). Electron spin polarization can be caused also on free radicals coming from other sources (such as the Haber-Weiss/Fenton reaction etc), as well as on those localized in the reactive centers of enzymes that catalyze free radical reactions. For antioxidant enzymes in particular, this may result in activity decrease and, subsequently, in the lowering of cell enzymic antioxidant defense. EMFs can also lower non-enzymic antioxidant defense (e.g. decrease in normal melatonin concentration etc) by non-linear metabolic processes, which, in addition, can amplify further the primary EMF effect of free radical concentration increase. This, therefore, will result in amplification of oxidative stress to levels beyond the antioxidant capacity of the cell, and, consequently, in disease development

particular, EMF-induced ROS have been assessed non-specifically by various methods (e.g. using spin traps such as *N-tert-butyl- α -phenylnitron* and *α -(4-pyridyl-1-oxide)-*N-tert-butyl*nitron* and *N-tert-Butyl- α -phenylnitron*^{10,128,129,166}, chemiluminescence¹⁰¹, nitroblue tetrazolium chloride,^{126,127,160,165} and fluorescence traps such as dihydrorhodamine 123^{119,127,160,161,165,194} and dichlorofluorescein diacetate^{32,33,94,104,112}. For example, the dihydrorhodamine 123 fluorescence assay used for detecting ROS does not only discriminate among the various ROS constituents but also between ROS and RNS since it detects indiscriminately superoxide radical, hydrogen peroxide, hypochlorous acid and peroxy nitrite anions¹²⁷. Even in the exception studies where superoxide radical was specifically detected by the SOD-inhibited reduction it causes to ferricytochrome *c*, this assay is inherently restricted for the *in vitro* detection of superoxide radical secreted by cell cultures (e.g. human neutrophils¹⁰⁴) or in rat heart homogenates prepared after RF exposure and sacrifice¹⁵⁵. Furthermore, lipid damage (peroxidation) and protein oxidation (formation of carbonyls, oxidation of –SH groups etc) and certain DNA damage (such as 8-hydroxy-2'-deoxyguanosine formation) can be repaired by the cell. Thus, their non-detection does not imply absence of oxidative stress necessarily. Moreover, perturbed levels of the antioxidant enzymes (SOD, CAT and GPx) and the natural antioxidants (melatonin, GSH, vitamin C etc) can be attributed to oxidative stress as well as to its absence since antioxidant defense is mostly adaptive. Therefore, the oxidative stress mechanism requires more conclusive *in vivo* quantitative verification by seeking (a) direct evidence for the formation of oxygen free radicals, and (b) indirect evidence for the creation of non-repaired biological damage during and/or after EMF exposure.

It has been already pointed out that the central element of oxidative stress is superoxide radical since it is the primary source of other ROS. Thus, the quantification *in vivo* of this most important free radical during EMF exposure will provide conclusive proof for the involvement of the oxidative stress mechanism and its complementary free radical pair mechanism as well. The methodology for the quantification of superoxide radical has been recently developed^{195,196}, thus, providing an invaluable tool for future studies. On the other hand, the RNS component NO, besides the non-availability of *in vivo* specific assays for its quantification, is not a reliable free radical identifier of oxidative stress because of its many physiological functions. Non-repairable DNA damage constitutes a very valid indirect evidence for the involvement of oxidative stress, as long as it is evaluated quantitatively as DNA fragmentation. Traditionally, genotoxicity in EMF studies has been evaluated by qualitative assays, and it has been disputed as non-reproducible for that matter as well. This problem can be overcome today by the availability of quantitative ultrasensitive assays for assessing non-repairable DNA damage. Such assays measure general DNA fragmentation (0-23 Kb), even small-size (0-1 Kb) necrotic/apoptotic DNA¹⁹⁷⁻²⁰⁰. These assays actually replace the cumbersome and problematic Comet assay and the agarose electrophoresis DNA-smearing assay, both being qualitative assays.

Both superoxide radical and DNA fragmentation assays can be also used in epidemiological EMF-related studies, e.g. to monitor the antioxidant status of the selected participants. The principle behind this approach is that, if antioxidants are taken up by human subjects as part of their every day diet (or in the form of dietary supplements) they should reach the bloodstream and enter the blood cells, enhancing the ability of these cells (as well as of the plasma lipids) to resist oxidative attack when challenged *in vitro* with a source of reactive oxygen²⁰¹. The DNA damage assays, in particular, can be used to monitor the antioxidant resistance of isolated lymphocytes to DNA damage e.g.

induced by H₂O₂. In addition, thiol redox state (TRS) is another parameter for the evaluation of the antioxidant status of man (e.g. by testing blood). Recently available quantitative assays of TRS measure the main TRS components such as the oxidized/reduced protein and non-protein thiol fractions, as well as the specific antioxidant thiols glutathione (GSH) and cysteine (CSH) and their oxidized counterparts (GSSG and CSSC, respectively)^{202,203}. Moreover, the assays that quantify superoxide radical and non-repairable DNA damage¹⁹⁵⁻¹⁹⁹ may be used to derive specific quantitative markers for EMF-induced biological damage, which can be used for the determination of more reliable EMF exposure limits for the general population.

Acknowledgments

I am indebted to Prof. Demetri J. Photinos (Theoretical Physics of Liquid Crystals and Field Theory) from the University of Patras, Greece, for scrupulously examining the report sections referring to the physics of the radical pair mechanism and for his valuable suggestions. I also thank Konstantinos Grintzalis (my Ph.D. student) for his help in searching the literature related to EMF exposure and oxidative stress and in formulating the sections of this report. I would also like to thank Dr. Ioannis Pappastolou (Ph.D., postdoc fellow in my lab) for his corrections and suggestions. This article was financially supported by the Greek Ministry of Education and by the 'Karatheodoris' Programme of the University of Patras, Greece.

References

1. Valberg PA, Kavet R, Rafferty CN. Can low-level 50/60 Hz electric and magnetic fields cause biological effects? *Radiat Res* 1997; 148: 2-21.
2. Blank M, Goodman R. Electromagnetic fields may act directly on DNA. *J Cellul Biochem* 1997; 75: 369-74.
3. Grundler W, Kaiser F, Keilmann F, *et al.* Mechanisms of electromagnetic interaction with cellular systems. *Naturwissenschaften* 1992; 79: 551-9.
4. Steiner UE, Ulrich T. Magnetic field effects in chemical kinetics and related phenomena. *Chem Rev* 1989; 89: 147-51.
5. Brocklehurst B, McLauchlan KA. Free radical mechanism for the effects of environmental electromagnetic fields on biological systems. *Int J Radiat Biol* 1996; 69: 3-24.
6. Eveson RW, Timmel CR, Brocklehurst B, *et al.* The effects of weak magnetic fields on radical recombination reactions in micelles. *Int J Radiat Biol* 2000; 76: 1509-22.
7. Brocklehurst B. Magnetic fields and radical reactions: recent developments and their role in nature. *Chem Soc Rev* 2002; 31: 301-11.
8. Cheng KK, Day N, Cartwright R, *et al.* Exposure to power-frequency magnetic fields and the risk of childhood cancer. *Lancet* 1999; 354: 1925-931.
9. Zwiriska-Korczała K, Jochem J, Adamczyk-Sowa M, *et al.* Effect of extremely low frequency electromagnetic fields on cell proliferation, antioxidative enzyme activities and lipid peroxidation in 3T3-L1 preadipocytes: an *in vitro* study. *J Physiol Pharmacol* 2005; 56: 101-8.
10. Lai H, Singh NP. Magnetic-field-induced DNA strand breaks in brain cells of the rat. *Environ Health Perspect* 2004; 112: 687-94.
11. McLauchlan KA. Are environmental magnetic fields dangerous? *Physics World* 1992; 5: 41-5.
12. Canfield JM, Belford RL, Debrunner PG, *et al.* A perturbation theory treatment of oscillating magnetic fields in the radical pair mechanism. *Chem Physics* 1994; 182: 1-18.
13. Scaiano JC, Cozens FL, McLean J. Model for the rationalization of magnetic field effects *in vivo*. Application of the radical pair mechanism to biological systems. *Photochem Photobiol* 1994; 59: 585-9.
14. Grissom CB. Magnetic field effects in biology: a survey of possible mechanisms with emphasis on radical-pair recombination. *Chem Reviews* 1995; 95: 3-24.

15. Scaiano JC, Mohtat N, Cozens FL, *et al.* Application of the radical pair mechanism to free radicals in organized systems: Can the effects of 60 Hz be predicted from studies under static fields? *Bioelectromagnetics* 1994; 15: 549-54.
16. Halliwell B, Gutteridge CMJ. *Free Radicals in Biology and Medicine*. Oxford University Press, Oxford, 1999.
17. McLauchlan KA, Steiner UE. The spin-correlated radical pair as a reaction intermediate. *Mol Physics* 1991; 73: 241-63.
18. Chuang TJ, Hoffman GW, Eisenthal KB. Picosecond studies of the cage effect and collision induced predissociation of iodine in liquids. *Chem Phys Letters* 1974; 25: 201-5.
19. Werner H-J, Schulten Z, Schulten K. Theory of the magnetic field modulated geminate recombination of radical ion pairs in polar solvents: application to the pyrene-N,N -dimethylaniline system. *J Chem Physics* 1977; 67: 646-63.
20. de Leiris J. *Biochemistry of free radicals*. *Heart Metab* 2003; 19: 40-4.
21. Bertini I, Luchinat C, Parigi G. Hyperfine shifts in low-spin iron (III) hemes: A ligand field analysis. *Eur J Inorg Chem* 2000; 2473-80.
22. Bartoszek M, Balanda M, Skrzypek D, *et al.* Magnetic field effect on hemin. *Physica B* 2001; 307: 217-23.
23. Drose S, Brandt U. The mechanism of mitochondrial superoxide production by the cytochrome bc₁ complex. *J Biol Chem* 2008; 283: 21649-54.
24. Batchelor SN, McLauchlan KA, Shkrob IA. Reaction yield detected magnetic resonance and magnetic field effect studies of radical pairs containing electronically excited organic radicals. *Mol Physics* 1992; 77: 75-110.
25. Batchelor SA, Kay CWM, McLauchlan KA, *et al.* Electron spin polarization (CIDEP) and magnetic field effects (MFE) in systems involving sulfur-centered radicals. *J Phys Chem* 1993; 97: 4570-2.
26. Hamilton CA, Hewitt JP, McLauchlan KA. High resolution studies of the effects of magnetic fields on chemical reactions. *Mol Physics* 1988; 65: 423-38.
27. Batchelor SN, Kay CWM, McLauchlan KA, *et al.* Time-resolved and modulation methods in the study of the effects of magnetic-fields on the yields of free-radical reactions. *J Phys Chem* 1993; 97: 13250-8.
28. Cozens FL, Scaiano JC. A comparative study of MF effects on the dynamics of geminate and random radical pair processes in micelles. *J Am Chem Soc* 1993; 115: 5204-11.
29. Scaiano JC, Abuin EB, Stewart LC. Photochemistry of benzophenone in micelles. Formation and decay of radical pairs. *J Am Chem Soc* 1982; 104: 5673-9.
30. Mohtat N, Cozens FL, Hancock-Chen T, *et al.* Magnetic field effects on the behavior of radicals in protein and DNA environments. *Photochem Photobiol* 1998; 67: 111-8.
31. Woodward JR, Jackson RJ, Timmel CR, *et al.* Resonant radiofrequency magnetic field effects on a chemical reaction. *Chem Physics Letters* 1997; 272: 376-82.
32. Roy S, Noda Y, Eckert V, *et al.* The phorbol 12-myristate 13-acetate (PMA)-induced oxidative burst in rat peritoneal neutrophils is increased by a 0.1 mT (60 Hz) magnetic field. *FEBS Lett* 1995; 376: 164-6.
33. Zmyslony M, Politanski P, Rajkowska E, *et al.* Acute exposure to 930 MHz CW electromagnetic radiation *in vitro* affects reactive oxygen species level in rat lymphocytes treated by iron ions. *Bioelectromagnetics* 2004; 25: 324-8.
34. Woodward JR. Radical pairs in solution. *Prog React Kinet Mec* 2002; 27: 165-207.
35. Tanimoto Y, Fujiwara Y. Effects of high magnetic fields on photochemical reactions. In: Nalwa HS, ed. *Handbook of photochemistry and photobiology: Inorganic photochemistry*. American Scientific Publishers, Stevenson Ranch, CA: 2003; 413-46.
36. Hayashi H. *Introduction to dynamic spin chemistry*. World Scientific, Singapore, 2004.
37. Hore PJ. Rapporteur's report: sources and interaction mechanisms. *Progress Biophys Mol Biol* 2005; 87: 205-12.
38. Eichwald C, Walleczek J. Model for magnetic field effects on radical pair recombination in enzyme kinetics. *Biophys J* 1996; 71: 623-31.
39. Harkins TT, Grissom CB. Magnetic field effects on B12 ethanolamine ammonia lyase: Evidence for a radical mechanism. *Science* 1994; 263: 958-60.
40. Harkins TT, Grissom CB. The magnetic field dependent step in B12 ethanolamine ammonia lyase is radical pair recombination. *J Am Chem Soc* 1995; 117: 566-7.

41. Taraban MB, Leshina TV, Anderson MA, *et al.* Magnetic field dependence and the role of electron spin in heme enzymes: horseradish peroxidase. *J Am Chem Soc* 1997; 119: 5768-9.
42. Moller AC, Olsen LF. Effect of magnetic fields on an oscillating enzyme reaction. *J Am Chem Soc* 1999; 121: 6351-4.
43. Moller AC, Olsen LF. Perturbations of simple oscillations and complex dynamics in the peroxidase-oxidase reaction using magnetic fields. *J Phys Chem B* 2000; 104: 140-6.
44. Moller AC, Lunding A, Olsen LF. Further studies of the effect of magnetic fields on the oscillating peroxidase-oxidase reaction. *Phys Chem Chem Phys* 2000; 2: 3443-6.
45. Carson JJJ, Walleczek J. Response of the peroxidase-oxidase oscillator to light is controlled by MB⁺-NADH photochemistry. *J Phys Chem* 2003; 107: 8637-42.
46. Noda Y, Mori A, Liburdy RP, *et al.* Pulsed magnetic fields enhance nitric oxide synthase activity in rat cerebellum. *Pathophysiol* 2000; 7: 127-30.
47. Beinert H, Holm RH, Münck E. Iron-Sulfur clusters: Nature's modular, multipurpose structures. *Science* 1997; 277: 653-9.
48. Noodleman L, Case DA, Mousesca J-M. *et al.* Valence electron delocalization in polynuclear iron-sulfur clusters. *J Biol Inorg Chem* 1996; 1: 177-82.
49. De Carolis R, Marinelli F, Barteri M. Alteration of enzymic electron transfer reactions induced by microwaves emitted by GSM mobile phones. In: Harper AC, Buress RV, eds. *Mobile telephones: networks, applications, and performance*. Nova Science Publishers, Hauppauge NY, 2008; 11-26.
50. Fridovich I. Quantitative aspects of the production of superoxide anion radical by milk xanthine oxidase. *J Biol Chem* 1970; 245: 4053-7.
51. Galley FH, Walker EB, Howdle DP, *et al.* Regulation of nitric oxide synthase activity in cultured human endothelial cells: Effect of antioxidants. *Free Rad Biol Med* 1996; 21: 97-101.
52. Fridovich I. Superoxide dismutases. *Ann Rev Biochem* 1975; 44: 147-59.
53. Branco RJF, Fernandes PA, Ramos MJ. Cu,Zn Superoxide dismutase: distorted active site binds substrate without significant energetic cost. *Theor Chem Acc* 2006; 115: 27-31.
54. Sankarapandi S, Zweier JL. Evidence against the generation of free hydroxyl radicals from the interaction of copper,zinc-superoxide dismutase and hydrogen peroxide. *J Biol Chem* 1999; 274: 34576-83.
55. Samoilov M, Plyasunov S, Arkin AP. Stochastic amplification and signaling in enzymatic futile cycles through noise-induced bistability with oscillations. *Proc Natl Acad Sci USA* 2005; 102: 2310-5.
56. Fisun OI. 2D plasmon excitation and nonthermal effects of microwaves on biological membranes. *Bioelectromagnetics* 1993; 14: 57-66.
57. Pape HC, Driesang RB. Ionic mechanisms of intrinsic oscillations in neurons of the basolateral amygdaloid complex. *J Neurophysiol* 1998; 79: 217-26.
58. Chiu AWL, Bardakjian BL. Stochastic and coherence resonance in an *In silico* neural model. *Ann Biomed Engineering* 2004; 32: 732-43.
59. Grundler W, Keilmann F. Sharp resonances in yeast growth prove nonthermal sensitivity to microwaves. *Phys Rev Lett* 1983; 51: 1214-6.
60. Grundler W, Keilmann F. Resonant microwave effect on locally fixed yeast microcolonies. *Z Naturforsch* 1989; 44c: 863-6.
61. Walleczek J, Liburdy RP. Nonthermal 60 Hz sinusoidal magnetic-field exposure enhances ⁴⁵Ca²⁺ uptake in rat thymocytes: dependence on mitogen activation. *FEBS Lett* 1990; 271: 157-60.
62. Conti P, Gigante GE, Alesse E *et al.* A role for Ca²⁺ in the effect of very low frequency electromagnetic field on the blastogenesis of human lymphocytes. *FEBS Lett* 1985; 181: 28-32.
63. Conti P, Gigante GE, Cifone MG, *et al.* Effects of electromagnetic field on two calcium dependent biological systems. *J Bioelectr* 1985; 4: 227-36.
64. Woggon WD. Cytochrome P450: Significance, reaction mechanisms and active site analogues. In Balzani V, Houk KN, Kessler H, *et al.*, eds. *Topics in Current Chemistry*. Springer-Verlag, Berlin, 1996; 39-96.
65. Efimova O, Hore PJ. Role of exchange and dipolar interactions in the radical pair model of the avian magnetic compass. *Biophys J* 2008; 94: 1565-74.
66. Rodgers CT, Hore PJ. Chemical magnetoreception in birds: The radical pair mechanism. *PNAS* 2009; 106: 353-60.
67. Ritz T, Thalau P, Phillips JB, *et al.* Resonance effects indicate a radical-pair mechanism for avian magnetic compass. *Nature* 2004; 429: 177-80.

68. Binhi V. Do naturally occurring magnetic nanoparticles in the human body mediate increased risk of childhood leukaemia with EMF exposure? *Int J Rad Biol* 2008; 84: 569-79.
69. Simkó M. Cell type specific redox status is responsible for diverse electromagnetic field effects. *Curr Med Chem* 2007; 14: 1141-52.
70. Sies H. Oxidative stress: introductory remarks. *In Oxidative Stress*. Sies H. Eds.: 1-7. Academic Press, New York, 1985.
71. Docampo R. Antioxidant mechanisms. *In Biochemistry and molecular biology of parasites*. Marr J. Müller M, Eds.: 147-160. Academic Press, London, 1995. .
72. Rice-Evans CA. Oxygen toxicity, free radicals and antioxidants in human disease: biochemical implications in atherosclerosis and the problems of premature neonates. *Essays Biochem* 1995; 29: 39-63.
73. Valko M, Morris H, Cronin MT. Metals, toxicity and oxidative stress. *Curr Med Chem* 2005; 12: 1161-208.
74. Haber F, Weiss J. On the catalysis of hydroperoxide. *Naturwissenschaften* 1932; 20: 948-50.
75. Koppenol WH. The Haber-Weiss cycle – 70 years later. *Redox Report* 2001; 6: 229-34.
76. Fenton HJH. Oxidation of tartaric acid in presence of iron. *J Chem Soc Trans* 1894; 65: 899-911.
77. Epe B, Ballmaier D, Roussyn I, *et al*. DNA damage by peroxynitrite characterized with DNA repair enzymes. *Nucleic Acids Res* 1996; 24: 4105-10.
78. Turko IV, Ferid M. Protein nitration in cardiovascular diseases. *Pharmacol Rev* 2002; 54: 619-34.
79. Pacher P, Beckman JS, Liaudet L. Nitric oxide and peroxynitrite in health and disease. *Physiol Reviews* 2007; 87: 315-424.
80. Rubo H, Radi R, Anselmi D, *et al*. Nitric oxide reaction with lipid peroxyl radicals spares alpha-tocopherol during lipid peroxidation. Greater oxidant protection from the pair nitric oxide/alpha-tocopherol than alpha-tocopherol/ascorbate. *J Biol Chem* 2000; 275: 10812-8.
81. Padmaja S, Huie RE. The reaction of nitric oxide with organic peroxyl radicals. *Biochem Biophys Res Commun* 1993; 195: 539-44.
82. Hausladen A, Fridovich I. Superoxide and peroxynitrite inactivate aconitases, but nitric oxide does not. *J Biol Chem* 1994; 269: 29405-8.
83. Gardner RP, Raineri I, Epstein BL, *et al*. Superoxide radical and iron modulate aconitase activity in mammalian cells. *J Biol Chem* 1995; 270: 13399-405.
84. Gardner RP, Fridovich I. Inactivation-reactivation of aconitase in *Escherichia coli*. *J Biol Chem* 1992; 267: 8757-63.
85. Gardner R P, Fridovich I. Superoxide sensitivity of the *Escherichia coli* aconitase. *J Biol Chem* 1991; 266: 19328-33.
86. Castro L, Rodriguez M, Radi R. Aconitase is readily inactivated by peroxynitrite, but not by its precursor, nitric oxide. *J Biol Chem* 1994; 269: 29409-15.
87. Flint HD, Tuminello FJ, Emptage HM. The inactivation of Fe-S cluster containing hydro-lyases by superoxide. *J Biol Chem* 1993; 268: 22369-76.
88. Galaris D, Skiadaa V, Barboutia A. Redox signaling and cancer: The role of “labile” iron. *Cancer Lett* 2008; 266: 21-9.
89. Lai H. Evidence for genotoxic effects (RFR and ELF genotoxicity). *In BioInitiative Report vol. 1: Biologically-based standards for low-intensity electromagnetic radiation (Section 6)*. Sage S, Carpenter D, Eds.: 2004: 1-14.
90. Babincova M, Babinec P. Dopamine mediated iron release from ferritin is enhanced at higher temperatures: Possible implications for fever-induced Parkinson’s disease. *J. Magnetism Magnetic Materials* 2005; 293: 341-4.
91. Barnham KJ, Bush AI. Metals in Alzheimer’s and Parkinson’s diseases. *Curr Opin Chem Biol* 2008; 12: 222-8.
92. Vojtisek M, Knotkova J, Kasparova L, *et al*. Metal, EMF, and brain energy metabolism. *Electromagn Biol Med* 2009; 28: 188-93.
93. Kula B, Sboczak A, Kuska R. Effects of electromagnetic field on free radical processes in steelworkers. *J Occup Health* 2002; 44: 226-9.
94. Zmyslony M, Rajkowska E, Mamrot P, *et al*. The effect of weak 50 Hz magnetic fields on the number of free oxygen radicals in rat lymphocytes. *Bioelectromagnetics* 2004; 25: 607-12.
95. Zmyslony M, Jajt J, Rajkowska E, *et al*. Weak (5 mT) static magnetic field stimulates lipid peroxidation in isolated rat liver microsomes *in vitro*. *Electrobiol Magnetobiol* 1998; 17: 109-13.

96. Fiorani M, Biagiarelli B, Vetrano F, *et al.* *In vivo* effects of 50 Hz magnetic fields on oxidatively damaged rabbit red blood cells. *Bioelectromagnetics* 1997; 18: 125-31.
97. Jajte J, Zmyslony M, Palus J, *et al.* Protective effect of melatonin against *in vitro* iron ions and 7 mT 50 Hz magnetic field-induced DNA damage in rat lymphocytes. *Mutat Res* 2001; 483: 57-64.
98. Zmyslony M, Palus J, Jajte J, *et al.* DNA damage in rat lymphocytes treated *in vitro* with iron cations and exposed to 7 mT magnetic fields (static or 50 Hz). *Mutat Res* 2000; 453: 89-96.
99. Jajte J, Grzegorzczak J, Zmyslony M, *et al.* Effect of 7 mT static magnetic field and iron ions on rat lymphocytes: apoptosis, necrosis and free radical processes. *Bioelectrochem* 2002; 57: 107-11.
100. Singh NP, Lai H. 60 Hz magnetic field exposure induces DNA cross-links in rat brain cells. *Mutat Res* 1998; 400: 313-20.
101. Lee B-C, Johng H-M, Lim J-K, *et al.* Effects of extremely low frequency magnetic field on the antioxidant defense system in mouse brain: a chemiluminescence study. *J Photochem Photobiol* 2004; 73: 43-8.
102. Jurek D, Udilova N, Schulte-Hermann R. Dietary lipid hydroperoxides induce expression of vascular endothelial growth factor (VEGF) in human colorectal tumor cells. *FASEB J* 2005; 19: 97-9.
103. Zmyslony M, Palus J, Dziubaltowska E, *et al.* Effects of *in vitro* exposure to power frequency magnetic fields on UV-induced DNA damage of rat lymphocytes. *Bioelectromagnetics* 2004; 25: 560-2.
104. Khadir R, Morgan JL, Murray JJ. Effects of 60 Hz magnetic field exposure on polymorphonuclear leukocyte activation. *Biochim. Biophys. Acta* 1999; 1472: 359-67.
105. Shen HM, Dong SY, Ong CN. Critical role of calcium overloading in cadmium induced apoptosis in mouse thymocytes. *Toxicol Appl Pharmacol* 2001; 171: 12-9.
106. Walleczek J. Electromagnetic field effects on cells of the immune system: the role of calcium signaling. *FASEB J* 1992; 6: 3177-85.
107. Pinthong M, Black SAG, Ribeiro FM, *et al.* Activity and subcellular trafficking of the sodium-coupled choline transporter CHT is regulated acutely by peroxyxynitrite. *Mol Pharmacol* 2008; 73: 801-82.
108. Agrawal YP. Low dose naltrexone therapy in multiple sclerosis. *Med Hypotheses* 2005; 64: 721-4.
109. Lai H, Carino MA, Horita A, *et al.* Effects of a 60 Hz magnetic field on central cholinergic systems of the rat. *Bioelectromagnetics* 1993; 14: 5-15.
110. Katsir G, Parola AH. Enhanced proliferation caused by a low frequency weak magnetic field in chick embryo fibroblasts is suppressed by radical scavengers. *Biochem Biophys Res Com* 1998; 252: 753-6.
111. Parola AH, Kost D, Katsir G, *et al.* Radical scavengers suppress low frequency EMF enhanced proliferation in cultured cells and stress effects in higher plants. *The Environmentalist* 2005; 25: 103-11.
112. Wolf FI, Torsello A, Tedesco B, *et al.* 50-Hz extremely low frequency electromagnetic fields enhance cell proliferation and DNA damage: Possible involvement of a redox mechanism. *Biochim Biophys Acta* 2005; 1743: 120-9.
113. Chignell CF, Sik RH. The effect of static magnetic fields on the photohemolysis of human erythrocytes by ketoprofen. *Photochem Photobiol* 1998; 67: 591-5.
114. Watanabe Y, Nakagawa M, Miyakoshi Y. Enhancement of lipid peroxidation in the liver of mice exposed to magnetic fields. *Indust Health* 1997; 35: 285-90.
115. Korf HW, Schomerus C, Maronde E, *et al.* Signal transduction molecules in the rat pineal organ: Ca²⁺, pCREB, and ICER. *Naturwissenschaften* 1996; 83: 535-43.
116. Reiter RJ, Tan DX, Poeggeler B, *et al.* Inconsistent suppression of nocturnal pineal melatonin synthesis and serum melatonin levels in rats exposed to pulsed DC magnetic fields. *Bioelectromagnetics* 1998; 19: 318-29.
117. Payne CM, Bernstein C, Bernstein H. Apoptosis overview emphasizing the role of oxidative stress, DNA damage, and signal-transduction pathways. *Leukem Lymphoma* 1995; 19: 43-93.
118. Chater S, Abdelmelek H, Couton D, *et al.* Sub-acute exposure to magnetic field induced apoptosis in thymus female rats. *Pak J Med Sci* 2005; 21: 292-7.
119. Lantow M, Lupke M, Frahm J, *et al.* ROS release and Hsp70 expression after exposure to 1,800

- MHz radiofrequency electromagnetic fields in primary human monocytes and lymphocytes. *Radiat Environ Biophys* 2006; 45: 55-62.
120. Paulraj R, Behari J. The effect of low level continuous 2.45 GHz waves on enzymes of developing rat brain. *Electromagn Biol Med* 2002; 21: 221-31.
 121. Sauer H, Wartenberg M, Hescheler J. Reactive oxygen species as intracellular messengers during cell growth and differentiation. *Cellular Physiol. Biochem* 2001; 11: 173-86.
 122. Irmak MK, Oztas E, Yagmurca M, *et al.* Effects of electromagnetic radiation from a cellular telephone on epidermal Merkel cells. *J Cutaneous Pathol* 2003; 30: 135-8.
 123. Maggiora M, Rossi MA. The exocytosis induced in HL-60 cells by 4-hydroxynonenal, a lipid peroxidation product, is not prevented by reduced glutathione. *Cell Biochem Funct* 2006; 24: 1-6.
 124. Phillips JL, Singh NP, Lai H. Electromagnetic fields and DNA damage. *Pathophysiology* 2009; 16: 79-88.
 125. Luo Y, Henle ES, Linn S. Oxidative damage to DNA constituents by Iron-mediated Fenton reactions. *J Biol Chem* 1996; 271: 21167-76.
 126. Simkó M, Droste S, Kriehuber R, *et al.* Stimulation of phagocytosis and free radical production in murine macrophages by 50 Hz electromagnetic fields. *Eur J Cell Biol* 2001; 80: 562-6.
 127. Lupke M, Rollwitz J, Simkó M. Cell activating capacity of 50 Hz magnetic fields to release reactive oxygen intermediates in human umbilical cord blood-derived monocytes and in Mono Mac 6 cells. *Free Rad Res* 2004; 38: 985-93.
 128. Lai H, Singh NP. Melatonin and a spin-trap compound block radiofrequency electromagnetic radiation-induced DNA strand breaks in rat brain cells. *Bioelectromagnetics* 1997; 18: 446-54.
 129. Lai H, Singh NP. Melatonin and N-tert-butyl-alpha-phenylnitronone block 60-Hz magnetic field-induced DNA single and double strand breaks in rat brain cells. *J Pineal Res* 1997; 22: 152-62.
 130. Yokus B, Cakir DU, Akdag MZ, *et al.* Oxidative DNA damage in rats exposed to extremely low frequency electro magnetic fields. *Free Rad Res* 2005; 39: 317-23.
 131. Koana T, Okada MO, Ikehata M, *et al.* Increase in the mitotic recombination frequency in *Drosophila melanogaster* by magnetic field exposure and its suppression by vitamin E supplement. *Mutat Res* 1997; 373: 55-60.
 132. Lai H, Singh NP. Single- and double-strand DNA breaks in rat brain cells after acute exposure to radiofrequency electromagnetic radiation. *Int J Radiat Biol* 1996; 69: 513-21.
 133. Lai H, Singh NP. Acute low-intensity microwave exposure increases DNA single-strand breaks in rat brain cells. *Bioelectromagnetics* 1995; 16: 207-10.
 134. Lalo UV, Pankratov YV, Mikhailik OM. Steady magnetic fields effect on lipid peroxidation kinetics. *Redox Report* 1994; 1: 71-5.
 135. Piruzyan LA, Aristarkhov VM. Spin and magnetic effects in biological systems are the privilege of membrane phospholipids. *Doklady Biochem Biophys* 2005; 401: 139-41.
 136. Coskun S, Balabanli B, Canseven A, *et al.* Effects of continuous and intermittent magnetic fields on oxidative parameters *in vivo*. *Neurochem Res* 2008; 34: 238-43.
 137. Seyhan N, Canseven AG. *In vivo* effects of ELF MFs on collagen synthesis, free radical processes, natural antioxidant system, respiratory burst system, immune system activities, and electrolytes in the skin, plasma, spleen, lung, kidney, and brain tissues. *Electromagn Biol Med* 2006; 25: 291-305.
 138. Zwirska-Korczała K, Adamczyk-Sowa M, Polaniak R, *et al.* Influence of extremely-low-frequency magnetic field on antioxidative melatonin properties in AT478 murine squamous cell carcinoma culture. *Biol Trace Elem Res* 2004; 102: 227-43.
 139. Bediz CS, Baltaci AK, Mogulkoc R, *et al.* Zinc supplementation ameliorates electromagnetic field-induced lipid peroxidation in the rat brain. *Tohoku J Exp Med* 2006; 208: 133-40.
 140. Ozturk A, Baltachi AK, Mogulkoc R, *et al.* Zinc prevention of electromagnetically-induced damage to rat testicle and kidney tissues. *Biol Trace Elem Res* 2003; 96: 245-54.
 141. Bray TM, Bettger WJ. The physiological role of zinc as an antioxidant. *Free Rad Biol Med* 1990; 8: 281-91.
 142. Kula B, Obczak A, Kuska R. Effects of static and ELF magnetic fields on free-radical processes in rat liver and kidney. *Electro-Magnetobiol* 2000; 19: 99-105.
 143. Hashish AH, El-Missiry MA, Abdelkader HI, *et al.* Assessment of biological changes of continuous whole body exposure to static magnetic field and extremely low frequency electromagnetic fields in mice. *Ecotoxicol Environ Safety* 2008; 71: 895-902.

144. Moustafa YM, Moustafa RM, Belacy, *et al.* Effects of acute exposure to the radiofrequency fields of cellular phones on plasma lipid peroxide and antioxidant activities in human erythrocytes. *J Pharm Biomed Anal* 2001; 26: 605-8.
145. Stopczyk D, Gnitecki W, Buczynski A, *et al.* Effect of electromagnetic field produced by mobile phones on the activity of superoxide dismutase (SOD-1) and the level of malonyldialdehyde (MDA) -*in vitro* study. *Medycyna Pracy* 2002; 53: 311-4.
146. Oktem F, Ozguner F, Mollaoglu H, *et al.* Oxidative damage in the kidney induced by 900-MHz-emitted mobile phone: Protection by melatonin. *Arch Med Res* 2005; 36: 350-5.
147. Balci M, Devrim E, Durak I. Effects of mobile phones on oxidant/antioxidant balance in cornea and lens of rats. *Curr Eye Res* 2007; 32: 21-5.
148. Dasdag S, Akdag MZ, Aksen F, *et al.* Does 900 MHz GSM mobile phone exposure affect rat brain? *Electromagn Biol Med* 2004; 23: 201-14.
149. Ilhan A, Gurel A, Armutcu F, *et al.* *Ginkgo biloba* prevents mobile phone-induced oxidative stress in rat brain. *Clin Chim Acta* 2004; 340: 153-62.
150. Meral I, Mert H, Mert N, *et al.* Effects of 900-MHz electromagnetic field emitted from cellular phone on brain oxidative stress and some vitamin levels of guinea pigs. *Brain Res* 2007; 1169: 120-4.
151. Ozguner F, Bardak Y, Comlekci S. Protective effects of melatonin and caffeic acid phenethyl ester against retinal oxidative stress in long-term use of mobile phone: A comparative study. *Mol Cell Biochem* 2006; 282: 83-8.
152. Ozguner F, Oktem F, Ayata A, *et al.* A novel antioxidant agent caffeic acid phenethyl ester prevents long-term mobile phone exposure-induced renal impairment in rat. *Mol Cell Biochem* 2005; 277: 73-80.
153. Ozguner F, Altinbas A, Ozaydin M, *et al.* Mobile phone-induced myocardial oxidative stress: protection by a novel antioxidant agent caffeic acid phenethyl ester. *Toxicol Ind Health* 2005; 21: 223-30.
154. Yurekli AI, Ozkan M, Kalkan T, *et al.* GSM base station electromagnetic radiation and oxidative stress in rats. *Electromagn Biol Med* 2006; 25: 177-88.
155. Kim MJ, Rhee SJ. Green tea catechins protect rats from microwave-induced oxidative damage to heart tissue. *J Med Food* 2004; 7: 299-304.
156. Kim MJ, Cho JH, Kim SY, *et al.* Effects of green tea catechin on enzyme activities and gene expression of antioxidative system in rat liver exposed to microwave. *Nutr Res* 2002; 22: 733-44.
157. Devrim E, Erguder B, Klcolu B, *et al.* Effects of electromagnetic radiation use on oxidant/antioxidant status and DNA turn-over enzyme activities in erythrocytes and heart, kidney, liver, and ovary tissues from rats: possible protective role of vitamin C. *Toxicol Mech Methods* 2008; 18: 679-83.
158. Koyu A, Ozguner F, Yilmaz HR, *et al.* The protective effect of caffeic acid phenethyl ester (CAPE) on oxidative stress in rat liver exposed to the 900 MHz electromagnetic field. *Toxicol Indust Health* 2009; 25: 429-34.
159. Tkalec M, Malaric K, Pevalak-Kozlina B. Exposure to radiofrequency radiation induces oxidative stress in duckweed *Lemna minor* L. *Sc Tot Env* 2007; 388: 78-89.
160. Rollwitz J, Lupke M, Simkó M. Fifty-hertz magnetic fields induce free radical formation in mouse bone marrow-derived promonocytes and macrophages. *Biochim Biophys Acta* 2004; 1674: 231-8.
161. Frahm J, Lantow M, Lupke M, *et al.* Alteration in cellular functions in mouse macrophages after exposure to 50 Hz magnetic fields. *J Cell Biochem* 2006; 99: 168-77.
162. Sirmatel O, Sert C, Tumer C, *et al.* Change of nitric oxide concentration in men exposed to a 1.5 T constant magnetic field. *Bioelectromagnetics* 2007; 28: 152-4.
163. Irmak MK, Fadillioglu E, Gulec M, *et al.* Effects of electromagnetic radiation from a cellular telephone on the oxidant and antioxidant levels in rabbits. *Cell Biochem Funct* 2002; 20: 279-83.
164. Geiger JD, Nagy JI. Distribution of adenosine deaminase activity in rat brain and spinal cord. *J Neurosci* 1989; 6: 2707-14.
165. Lantow M, Schuderer J, Hartwig C, *et al.* Free radical release and HSP70 expression in two human immune-relevant cell lines after exposure to 1800 MHz radiofrequency radiation. *Rad Res* 2006; 165: 88-94.
166. Crouzier D, Perrin A, Torres G, *et al.* Pulsed electromagnetic field at 9.71 GHz increase free radical production in yeast (*Saccharomyces cerevisiae*). *Pathol Biol* 2009; 57: 245-51.

167. Parke DV, Sapota A. Chemical toxicity and reactive oxygen species. *Int J Occup Med Environ Health* 1996; 9: 331-40.
168. Erdal N, Gurgul S, Tamer L, *et al.* Effects of long-term exposure of extremely low frequency magnetic field on oxidative/nitrosative stress in rat liver. *J Radiat Res* 2008; 49: 181-7.
169. Oates JC, Christensen EF, Reilly CM, *et al.* Prospective measure of serum 3-nitrotyrosine levels in systemic lupus erythematosus: correlation with disease activity. *Proc Assoc Am Phys* 1999; 111: 611-21.
170. Tohgi H, Abe T, Yamazaki K, *et al.* Alterations of 3-nitrotyrosine concentration in the cerebrospinal fluid during aging and in patients with Alzheimer's disease. *Neurosci Letters* 1999; 269: 52-4.
171. Güler G, Turkozer Z, Ozgur E, *et al.* Protein oxidation under extremely low frequency electric field in guinea pigs. *Gen Physiol Biophys* 2009; 28: 47-55.
172. Falone S, Mirabilio A, Carbone MC, *et al.* Chronic exposure to 50Hz magnetic fields causes a significant weakening of antioxidant defense systems in aged rat brain. *Int J Biochem Cell Biol* 2008; 40: 2762-70.
173. Stranges S, Trevisan M, Dorn JM, *et al.* Body fat distribution, liver enzymes, and risk of hypertension. Evidence from the Western New York Study. *Hypertension* 2005; 46: 1186-93.
174. Elhag MA, Nabil GM, Attia AMM. Effects of electromagnetic field produced by mobile phones on the oxidant and antioxidant status of rats. *Pak J Biol Sc* 2007; 10: 4271-4.
175. Ozguner F, Oktem F, Armagan A, *et al.* Comparative analysis of the protective effects of melatonin and caffeic acid phenethyl ester (CAPE) on mobile phone-induced renal impairment in rat. *Mol Cell Biochem* 2005; 276: 31-7.
176. Lelli JL, Becks LL, Dabrowska MI, *et al.* ATP converts necrosis to apoptosis in oxidant-injured endothelial cells. *Free Rad Biol Med* 1998; 25: 694-702.
177. Lee YJ, Shacter E. Oxidative stress inhibits apoptosis in human lymphoma cells. *J Biol Chem* 1999; 274: 19792-8.
178. Evans MD, Cooke MS. Factors contributing to the outcome of oxidative damage to nucleic acids. *Bioessays* 2004; 26: 533-42.
179. Simkó M, Mattsson MO. Extremely low frequency electromagnetic fields as effectors of cellular responses *in vitro*: Possible immune cell activation. *J Cell Biochem* 2004; 93: 83-92.
180. Singh KK. Oxidative stress, disease and cancer. Imperial College Press, Hackensack, NJ, 2006.
181. Thomas CE. Oxygen free radicals and the disease process. CRC Press, New York, 1998.
182. Whitaker SH, Pierce JD. Oxygen free radicals and the disease process. *Nurse Pract* 2003; 28: 53-4.
183. Beckman KB, Ames BN. Oxidative decay of DNA. *J Biol Chem* 1997; 272: 19633-6.
184. Reiter RJ. Oxygen radical detoxification processes during aging: the functional importance of melatonin. *Aging (Milano)* 1995; 7: 340-51.
185. Stevens RG. Biologically based epidemiological studies of electric power and cancer. *Environ Health Persp* 1993; Suppl. 101: 93-100.
186. Kavet R. EMF and current cancer concepts. *Bioelectromagnetics* 1996; 17: 339-57.
187. Kheifets L, Shimkhada R. Childhood leukemia and EMF: review of the epidemiologic evidence. *Bioelectromagnetics* 2005; Suppl. 7: S51-S59.
188. Greenland S, Sheppard AR, Kaune WT, *et al.* A pooled analysis of magnetic fields, wire codes, and childhood leukemia. Childhood Leukemia-EMF Study Group. *Epidemiology* 2000; 11: 624-34.
189. Ahlbom A, Day N, Feychting M, *et al.* A pooled analysis of magnetic fields and childhood leukaemia. *Br J Cancer* 2000; 83: 692-8.
190. Lacy-Hulbert A, Metcalfe JC, Heskett R. Biological responses to electromagnetic fields. *FASEB J* 1998; 12: 395-420.
191. Ahlbom A. Neurodegenerative diseases, suicide and depressive symptoms in relation to EMF. *Bioelectromagnetics* 2001; 22: S132-S143.
192. Johansson O. Electrohypersensitivity: State-of-the-art of a functional impairment. *Electromagn Biol Med* 2006; 25: 245-58.
193. Adey WR. Potential therapeutic application of non-thermal electromagnetic fields: Ensemble organization of cells in tissue as a factor in biological field sensing. In: Rosch PJ, Markov MS, eds. *Bioelectromagnetic Medicine*. New York, Marcel Dekker, 2004; 1-12.

C.D. Georgiou: Biological damage by EMF-induced oxidative stress mechanism

194. REFLEX-Study. Risk evaluation of potential environmental hazards from low frequency electromagnetic field exposure using sensitive *in vitro* methods (www.verum-foundation.de, accessed on November 14, 2009), 2004.
195. Georgiou DC, Papapostolou I, Patsoukis N, *et al.* An ultrasensitive fluorescent assay for the *in vivo* quantification of superoxide radical in organisms. *Anal Biochem* 2005; 347: 144-51.
196. Georgiou DC, Papapostolou I, Grintzalis K. Superoxide radical detection in cells, tissues, organisms (animals, plants, insects, microorganisms) and soils. *Nature Protocols* 2008; 3: 1679-92.
197. Georgiou DC, Patsoukis N, Papapostolou I. Assay for the quantification of small-sized fragmented genomic DNA. *Anal Biochem* 2005; 339: 223-30.
198. Georgiou DC, Papapostolou N. Assay for the quantification of intact/fragmented genomic DNA. *Anal Biochem* 2006; 358: 247-56.
199. Georgiou DC, Papapostolou I, Patsoukis N, *et al.* Assays for the quantitative characterization of genomic, mitochondrial and plasmid DNA. In: Kimura H, Suzuki A, eds. *New research on DNA damage*. New York: Nova Science Publishers Inc; 2008; 183-95.
200. Georgiou DC, Papapostolou I, Grintzalis K. Protocol for the quantitative assessment of DNA concentration and damage (fragmentation and nicks). *Nature Protocols* 2009; 4: 125-31.
201. Collins AR. Assays for oxidative stress and antioxidant status: applications to research into the biological effectiveness of polyphenols. *Am J Clin Nutr* 2005; 18: S261-S267.
202. Patsoukis N, Georgiou DC. Determination of the thiol redox state of organisms: new oxidative stress indicators. *Anal Bioanal Chem* 2004; 378: 1783-92.
203. Patsoukis N, Georgiou DC. Fluorometric determination of thiol redox state. *Anal Bioanal Chem* 2005; 383: 923-29.

Effect of extremely low electromagnetic frequency on ion channels, actin distribution and cells differentiation

Mario Ledda*, Settimio Grimaldi*, Antonella Lisi*, Enrico D'Emilia**, Livio Giuliani**

* Institute of Neurobiology and Molecular Medicine, National Research Council INMM, Rome, Italy

** National Institute for Prevention and Safety at Work (ISPEL), Rome, Italy

Abstract

Living organisms are complex electrochemical systems being evolved in a relatively narrow range of well-defined environmental parameters. For life to be maintained these parameters must be kept within their normal range; since deviations can induce biochemical effects. Environmental natural electro-magnetic field is an ubiquitous factor in nature. If nature gave certain organisms the ability to receive information about the environment via invisible electromagnetic signals, then there must also have been the benefit of an ability to discriminate between significant and meaningless signals. The most evident example of adaptation of living creature to the environment electromagnetic component is the visual system: the eye is a biological tool committed to the perception of the entire visible electromagnetic spectrum. A great variety of living organisms are able to utilize the electromagnetic energy to regulate cellular or sensorial function such as in protein folding, circadian rhythm and in central nervous system function. Bearing in mind that electromagnetic field can be perceived by living organisms, we should not be amazed if they can consequently be able to induce biological effects. The discovery that electromagnetic signal can be associated to specific biological function is known since the time of Galvani and Matteucci. In the past century several studies indicated a correlation between some physiological and pathological processes and electromagnetic field. Despite the fact that electromagnetic therapy is already used in clinical trials such as in orthopedy, still we are debating about the mechanisms of the interaction between specific irradiation protocols and biological targets. The role of physical processes in participating in the organization of living matter are still far to be adequately understood. Organization in biological systems includes organization of morphological structures, of chemical reactions, and of physical fields. Physical fields may have an effect on the behavior of all structures in connection with the space-time dynamic functional order. As the majority of biological molecules and structures are electrically polar an electromagnetic mechanism in participating in their organization can not be neglected. We assume that especially the electric component of the endogenous electromagnetic field may be important for organization. Electric

component can exert forces on charges, on dipoles, and also on neutral particles. Electric field may be important for transport of molecules in cytoplasm between different reaction compartments, for active transport of molecules across plasma membrane, and for transfer of electrons. There have been many reports on the biological effects of simultaneously acting static (DC) magnetic and electric fields and frequency alternative (AC) magnetic or electromagnetic fields on membrane transport and physiological functions. These studies indicate that the mechanism of field exposures are not identical. While some reports show an inhibitory effect by the fields, others show activation, and still others no significant influences.

***Key words:* cyclotron resonance, ions transport, cell differentiation**

Effects of magnetic fields on membrane electrical properties

Membrane electrical properties such as membrane surface charge, membrane potential and so on may be directly influenced by eddy current induced by changing the flux density of magnetic field¹. There have been studies testing the effects of static or DC magnetic fields on some of the electric properties. Lisi *et al.*² to establish whether exposure to extremely low frequency electromagnetic field can affect the molecular biology of the pituitary gland continuously exposed a corticotrope-derived cell line (AtT20) to high flux intensity (2 mT) low frequency electromagnetic field. Double labeling cells with a calcium fluorophore (Indo-1) and a membrane potential fluorophore (DiI) showed on single cells fluorescence microscopy a statistically significant increase for intracellular calcium $[Ca^{2+}]_i$ and a cell membrane depolarization on AtT20 exposed cells. Two dimensional gel electrophoresis on total ³²P label proteins, extracted from AtT20 cells showed an increase in phosphorylated proteins comparing the extract from exposed to non exposed cells. Scanning Electron Microscopy of extremely low frequency (ELF) exposed AtT20 cells resulted in a morphological change of plasma membrane; this modification was accompanied by a rearrangement in actin filaments distribution, as detected by phalloidin fluorescence. Using monoclonal antibody to neurofilament protein (NF-H), demonstrated in the neurite like filament the presence of neurofilament protein. This result was confirmed by RT-PCR analysis. These data provide evidence that ELF electromagnetic fields may induce on AtT20 cells membrane depolarization followed by an increase in $[Ca^{2+}]_i$ and expression of NF-H. Santoro *et al.*³ have reported a decrease in membrane fluidity and re-organized cytoskeletal components on exposure to ELF magnetic field in human B lymphoid cells (Raji). Therefore, ELF magnetic fields would influence the structure of protein molecules composing the biomembrane^{4,7}. Static magnetic fields have been reported to affect the diffusion of biological particles in solutions by inducing Lorentz force or Maxwell stress. Lorentz force would influence the diffusion of charged particles such as various ions including plasma proteins. In fact, it has been reported that changes in electrical conductivity of CaCl₂ solution are caused by exposure to static magnetic fields (2.3-350 mT)^{8,9}.

Liburdy¹⁰ has detected an increase in calcium uptake into mitogen-stimulated rat thymocytes (mature) and human lymphocytes during exposure to 60 Hz ELF field or high-field Nuclear Magnetic Resonance (NMR). As NMR fields contain a time-varying magnetic field, this result implies that the time-varying field of NMR is an operative component responsible for the effect on calcium transport^{11,12}.

In the last decades, biology and medicine have made enormous progress in deciphering chemical and mechanical (molecular machines) aspects of cell and molecular biology¹³. The complex picture of the processes in the cell as well as in the tissue was supplemented by recent studies which show a correlation between the presence of electromagnetic field (EMF) gradients and cellular reactions. Such studies arose in embryology, physiology, as well as in molecular biology. Thus, EMF studies in experimental biology and (already applied) EMF therapies in medicine may now have the chance to show the link between the clear-cut causal explanations of physics and the observed cellular and organic change physiological relevance of EMF^{14, 15}.

Effect on cell proliferation and differentiation

EMF can affect cell proliferation and differentiation by influencing the expression of relevant genes and proteins¹⁶. Depending on the kind of EMF, both stimulation and inhibition of proliferation were observed. ELF EMF stimulated embryonic stem cell differentiation into cardiomyocytes by triggering the expression-specific cardiac lineage-promoting genes¹⁷. Similar magnetic field (MF) also stimulated proliferation and differentiation of neurons¹⁸. In contrast, static DC EF (2 V/cm) inhibited proliferation of vascular endothelial cells or lens epithelial cells by inducing a cell cycle arrest at the G1/S phase^{19,20}. In both cell types, DC EF significantly decreased the expression of cyclin E, whereas levels of the inhibitor of the cyclin E/Cdk2 complex, p27^{kip1}, increased. Further, the healing of lens epithelial monolayer wounds was inhibited at the cathodal side after exposure to DC EF²¹⁻²³. Extracellular signal-regulated kinase 1 and 2 activity was increased, but became asymmetrically distributed, with much weaker activity on the cathodal side than on the anodal side²⁴. Wound-generated endogenous DC EF can control the axis of cell division by orientation of mitotic spindles perpendicular towards the field vector. Higher MF densities were also able to orient the cleavage plane during mitosis or to distort the mitotic spindle²⁵.

We have recently studied mesenchymal stem cells (MSC) and demonstrated that exposure of human MSC (hMSC) to ELF-MF 7 Hz, Ion Cyclotron Resonance (ICR) enhanced expression of osteoblast marker differentiation such as Alkaline Phosphatase (AP), Osteocalcin (OCL), and Osteopontin (OPN), analyzed by quantitative RT-PCR, without affecting cell proliferation. As expected, while the markers differentiation factors were up regulated, electromagnetic field down regulate Osteoprotegerin (OPG) gene expression, a critical regulator of postnatal skeletal development and homeostasis in humans as well as mice²⁶. This exposure system was placed in an amagnetic shielded room in the simultaneous presence of a static MF and a low-alternating-frequency-MF, close to the cyclotron frequency corresponding to the charge/mass ratio of Ca²⁺ ion²⁷⁻³⁰. In this exposure conditions hMSC modulate their differentiation and 5 days of exposure resulted in a change in shape and in plasma membrane morphology and this modification was also accompanied by a rearrangement in actin filaments, as showed by confocal microscopy analysis after cells labelling with FITC-phalloidin. This may pave the way for novel approaches in tissue engineering and cell therapy.

Proposed mechanisms

According to Quantum Electro-Dynamical Theory by Preparata, liquid water can be viewed as an equilibrium between of two components: coherent and incoherent ones.

The coherent component is contained within spherical so called “coherence domains” (CDs) where all molecules synchronously oscillate with the same phase. CDs are surrounded by the incoherent component where molecules oscillate with casual phases regarding each other. The existence of coherent domain in water has been demonstrated in a set of experiments on pure water exposed to high voltage, under this condition the electric field concentrates inside the water, arranging the water molecules to form highly ordered structure^{31, 32}.

These results should increase the reliability and the clinical feasibility of the use of electromagnetic field, tuned at ion cyclotron resonance of charged molecules, as a biophysical approach to interfere with biological mechanisms. The middle of the eighties was marked with the discovery by Blackman³³ of a surprising phenomenon: a low AC MF is capable of changing free calcium concentrations in nervous tissue only in the presence of a DC MF. The most prominent effect was observed at the AC field frequency close to the cyclotron frequency of a calcium ion. The cyclotron frequency is defined as

$$f_c = \frac{q}{2\pi m} B_0$$

where q and m are the charge and mass of the ion, and B_0 is the magnetic field strength. This works opened a new line of research in the area of bioelectromagnetics.

There were three unexpected aspects to this phenomenon: 1) validity of the Lorentz law and the necessity for simultaneous application of DC and AC MFs, 2) tuning the AC and DC MFs to the cyclotron frequency resonance condition, and 3) very small values of acting MFs, measured in tens of μT , and extremely low frequencies of AC MFs, measured in tens of Hz or less. Therefore, these results evoked much suspicion in the scientific community. Afterwards, however, many confirmations for these data were obtained in works performed on different model systems and in different experimental situations which convinced the scientific community of the real existence of the above effects.

Earlier there were attempts to understand the physical mechanisms of resonance action of combined MFs. Liboff considered the motion of free ions under action of these MFs, suggesting a mechanism similar to the one working for charged particles in free space under the influence of the Lorentz force. But at body temperature this idea can be realized only in very large systems capable of including the large radius of ion rotation, measured by meters. The idea that parametric resonance might be responsible for such effects was also not very fruitful for lack of a necessary low frequency harmonic oscillator in living systems. Larmor precession also does not help in this situation, because of a lack of restoring force with proper parameters. The problem is likely solved using the quantum electrodynamics of condensed matter. Diameters of CDs are measured in terms of tenths of a micron, and at room temperature the total volume of domains is about 40% of the whole water media. At resonance action of the ion cyclotron frequency, the ion is accelerated by the MFs, increasing its kinetic energy till escape from CD, jumping into the incoherent component of the water molecule where the ion becomes biologically available. This has been scientifically supported by experiments performed in different laboratories studying the behaviour of glutamic acid at glutamic acid ion cyclotron resonance condition. Glutamic solution in an electrolytic cell was irradiated under controlled condition at extremely low frequency and the current flowing in the electrolic cell was

continuously recorded. When the resonant condition was reached at 4.1 Hz a peak of DC current was recorded.

Ion cyclotron resonance to transfer information at biological level

Water undoubtedly is the most important chemical substance in the world. The interaction of water with electric fields has been intensely explored over the last years. We report another unusual effect of liquid water exposed to a DC electric field: the “floating water bridge”. When submitted to a high-voltage electric field, water in two glass containers moved out of the glasses and crosses empty space to meet, forming the water bridge. Upon investigating the phenomenon, Fuchs³⁴ and colleagues found that water was being transported from one beaker to another, usually from the anode beaker to the cathode beaker. The cylindrical water bridge, with a diameter of 1-3 mm, could remain intact when the beakers were pulled apart at a distance of up to 25 mm. Initially, the bridge forms due to electrostatic charges on the surface of the water. The electric field then concentrates inside the water, arranging the water molecules to form a highly ordered microstructure. This microstructure remains stable, keeping the bridge intact. We repeated the Fuchs experience reaching the hypothesis that for the water bridge to exist, water molecule must be rearranged in stable microstructure physically closed to the Preparata water coherence domain. At this point we have to outline that the Newtonian force exerted on water molecules while they are crossing the polarised cell plasma membrane (when the membrane potential is set at -70 mV), is in the same order of magnitude of the Newtonian force exerted on water molecules that are crossing the water bridge in the Fuchs experiment. Thus, if this is the case, some water molecules crossing the cell membrane should be arranged in structure similar to what Preparata theorised for the coherence domain of water. In accord with Del Giudice³⁵ when water molecules become coherent, coherence domain are entropically stable, and all ions around them are trapped in an energy cage and are not biologically available. At the light of the above explanation membrane polarization and depolarization can not be only viewed as a process acting only on the active ions transport across the cell membrane but can also act as buffer system avoiding intracellular ions fluctuation by modulating the amount intracytoplasmic structured water in equilibrium with non ordered water. As stated above, ions around structured water are entropically stable; in addition all the ions in a region close to the structured water are in total absence of friction matching the condition for which Lorentz law is valid. An ion trapped around a water coherent domain must behave as an ion in the vacuum and if a static and uniform magnetic (B_0) is applied the ion will move in a circle orbit around the coherent domain due to the Lorentz force; applying an additional alternating magnetic field (B) with the same frequency of the ion circular frequency (ion cyclotron frequency) around the coherent dominion, energy will be transferred to the ion and if the energy of the applied alternate field is appropriate the ion will be removed from the orbits around the coherent dominion jumping into the non coherent water were became biologically available. While ions around water coherence domain are believed to be not biologically available at resonant action of the ion cyclotron frequency they will be removed from the coherence dominion to the normally structured water were they become biologically available.

Ion ciclotron bioresonance in regenerative medicine

Prometheus myth, is a fitting model for regenerative medicine. As punishment for giving fire to humanity, Zeus ordered Prometheus chained to a rock and sent an eagle to eat his liver each day. However, Prometheus' liver was able to regenerate itself daily, enabling him to survive. Today we hope to make the legendary concept of regeneration into reality by developing therapies to restore lost, damaged, or aging cells and tissues in the human body. For bone remodelling field, it has been suggested that bone marrow-derived MSC could be considered as a potential therapeutic tool. Using the Ca^{2+} dependent specific differentiation potential of the ELF-MF 7 Hz ICR²⁶, we showed that exposure of human MSC to these same conditions of MF, enhanced expression of osteoblast differentiation markers such as Alkaline Phosphatase, Osteocalcin, and Osteopontin, as analyzed by quantitative RT-PCR, without affecting cell proliferation. We recently published that exposing keratinocytes cells to ion cyclotron resonance, tuned at the Calcium resonance frequencies (7 Hz 10 μT), generated by a commercially available electromedical device, causes an increase of the differentiation and adhesion markers involucrin and $\beta\text{Catenin}$ respectively. This is a very important point suggesting a possible application of electrotherapy in the therapy of proliferative diseases.

Conclusions

Since the time of Galvani evidence has accumulated indicating that living systems make useful use of electromagnetic field. The major particles that constitute the functional organization of living systems are associated with electromagnetic fields. Organisms might be considered aggregates of electromagnetic fields that are embedded within or correlated with atomic and molecular structures. The use of EMF has a long history. In the first century AD, use of an electric fish was described to cure headache and gout. Later, Paracelsus studied the medical use of lodestone, and Sir Kenelm Digby described the magnetic cure of wounds. Modern - and more serious - medical applications of EMF are used to heal nonunions of bone fractures and treat some bone-related diseases (e.g., osteoporosis, osteoarthritis), although the specific molecular mechanisms are not fully understood. The application of EMF to stimulate osteogenesis is based on the idea of stimulating the natural endogenous streaming potentials in bone. Albeit electromagnetic medicine is still in its beginning, the evidence reported here, that ICR exposure can tune eucariotic cell towards cell differentiation and maturation, influencing physiological processes let foresee a possible future application of electromagnetic protocols for the treatment of human diseases.

References

1. Bauréus Koch CLM, Sommarin M, Persson BRR, *et al.* Interaction between weak low frequency magnetic fields and cell membranes. *Bioelectromagnetics* 2003; 24: 395-402.
2. Lisi A, Ledda M, Rosola E, *et al.* Extremely low frequency electromagnetic field promotes differentiation of pituitary corticotrope-derived AtT20 D16 cells. *Bioelectromagnetics* 2006; 27: 641-51.
3. Santoro N, Lisi A, Pozzi D, *et al.* Effect of extremely low frequency (ELF) magnetic field exposure on morphological and biophysical properties of human lymphoid cell line (Raji). *Biochem Biophys Acta* 1997; 1357: 281-90.

4. Adey WR. Tissue interaction with non-ionizing electromagnetic field. *Physiol Rev* 1981; 61: 435-514.
5. Adey WR. Biological effects of electromagnetic fields. *J Cell Biochem* 1993; 51(4): 410-6.
6. Barnes PS. Effect of electromagnetic field on the rate of chemical reactions. *Biophysics* 1996; 41: 801-8.
7. Basset CAL. Beneficial effects of electromagnetic fields. *J Cell Biochem* 1993; 51: 387-93.
8. Phillips JL, Haggren W, Thomas WJ, *et al.* Magnetic field-induced changes in specific gene transcription. *BBA* 1992; 1132: 140-4.
9. Rusovan A, Kanje M. Magnetic fields stimulate peripheral nerve regeneration hypophyctiomia rats. *Neuroreport* 1992; 3(12): 1039-41.
10. Liburdy RP. Calcium signalling in lymphocytes and ELF fields: evidence for an electromagnetic field metric and a site of interaction involving calcium ion channels. *FEBS Lett* 1992; 301(1): 53-9.
11. Walleczek J. Electromagnetic field effect on cells of the immune system: the role of calcium signalling. *FASEB J* 1992; 6: 3177-85.
12. Karabakhtsian R, Bronde N, Shalts N, *et al.* Calcium is necessary in the cell response to EM fields. *FEBS Lett* 1994; 301: 53-9.
13. Chiabrera A, Nicolini C, Schwan HP. Interactions between electromagnetic fields and cells. In Chiabrera A, Nicolini E, Schwan HP, eds; NATO ASI series. *Serves A, Life Science vol. 97.* Plenum Press, London, 1985.
14. Tenforde TS. Interaction of extremely low frequency electromagnetic and magnetic fields with humans. In Polk C, Postow E, eds, "Handbook of biological effects of electromagnetic fields". 2nd Ed. Boca Raton, FL: CRC Press, 1995, 185-230.
15. Frey AH. Electromagnetic field interactions with biological systems. *FASEB J* 1993; 7: 272-81.
16. Lisi A, Foletti A, Ledda M, *et al.* Extremely low frequency 7 Hz 100 microT electromagnetic radiation promotes differentiation in the human epithelial cell line HaCaT. *Electromagn Biol Med* 2006; 25(4): 269-80.
17. Gaetani R, Ledda M, Barile L, *et al.* Differentiation of human adult cardiac stem cells exposed to Extremely Low Frequency Electromagnetic Fields. *Cardiovasc Res* 2009; 82(3): 411-20.
18. Blackman CF, Benane SG, House DE, *et al.* Effects of ELF (1-120Hz) and modulated (50Hz) RF fields on the efflux of calcium ions from brain tissue in vitro. *Bioelectromagnetics* 1985; 6: 1-11.
19. Hinsenkamp M, Jercinovic A, De Graef Ch, *et al.* Effects of low frequency pulsed electromagnetic current on keratinocytes in vitro. *Bioelectromagnetics* 1997; 18: 250-4.
20. Medema JP, Sark MW, Backendorf C, *et al.* Calcium inhibits epidermal growth factor- induced activation of p21ras in human primary keratinocytes. *Mol Cell Biol* 1994; 14(11): 7078-85.
21. Peus D, Hamacher L, Pittelkow MR. EGF-receptor tyrosine kinase inhibition induces keratinocytes growth arrest and terminal differentiation. *J Invest Derm* 1997; 109: 751-6.
22. Szabo I, Rojavin MA, Rogers TJ, *et al.* Reactions of keratinocytes to in vitro millimeter wave exposure. *Bioelectromagnetics* 2001; 22: 358-64.
23. Vasioukhin V, Bauer C, Degenstein L, *et al.* Hyperproliferation and defects in epithelial polarity upon conditional ablation of alpha-catenin in skin. *Cell* 2001; 104(4): 605-17.
24. Fukunaga M, Oka M, Ichihashi M, *et al.* UV-Induced Tyrosine Phosphorylation of PKC delta and Promotion of Apoptosis in the HaCaT Cell Line. *Biochem Biophys Res Commun* 2001; 289(2): 573-9.
25. Weaver JC, Astumian RD. The response of living cells on very weak electromagnetic fiels: the thermal noise limit. *Science* 1990; 247: 459-62.
26. Lisi A, Ledda M, De Carlo F, *et al.* Ion cyclotron resonance as a tool in regenerative medicine. *Electromagn Biol Med* 2008; 27(2): 127-33.
27. Zhadin MN. Review of russian literature on biological action of DC and low-frequency AC magnetic fields. *Bioelectromagnetics* 2001; 22(1): 27-45.
28. Liboff AR. Cyclotron resonance in membrane transport. In Chiabrera A, Nicolini C, Schwan HP eds. *Interaction between electromagnetic fields and cells.* London; Plenum Press 1985; 281-96.
29. Liboff AR, Smith SD, McLeod BR. Experimental evidence for ion cyclotron resonance mediation of membrane transport. In Blank M, Findl E, eds. *Mechanistic Approaches to Interaction of Electric and Electromagnetic Fields with Living Systems.* New York Plenum Press 1987; 109-32.
30. Liboff AR. Electric-field ion cyclotron resonance. *Bioelectromagnetics* 1997; 18: 85-7.

31. Kaiser F. Theory of non-linear excitation. In Frolich H, ed. Biological coherence and response to external stimuli. Springer Heidelberg Germany 1988; 25-48.
32. Liboff AR. Toward an electromagnetic paradigm for biology and medicine. *J Altern Complement Med* 2004; 10: 41-7.
33. Blackman CF, Benane SG, Rabinowitz JR, *et al.* A role for the magnetic field in the radiation induced efflux of Calcium ions from brain tissue in vitro. *Bioelectromagnetics* 1985; 6(4): 327-37.
34. Fuchs EC, Woisetschläger J, Gatterer K, *et al.* The floating water bridge. *J Phys D: Appl Phys* 2007; 40: 6112-4.
35. Del Giudice E, Tedeschi A. Water and autocatalysis in living matter. *Electromagn Biol Med* 2009; 28(1): 46-52.

Genotoxic properties of extremely low frequency electromagnetic fields

Ion Udrouiu*, Livio Giuliani*, Luisa Anna Ieradi**

* National Institute for Prevention and Safety at Work, Rome, Italy

** Institute for the Study of Ecosystems, CNR, Rome, Italy

Abstract

Many authors have examined the genotoxic properties of magnetic fields. Some studies detected increases in micronuclei frequencies and chromosomal aberrations in samples taken from individuals professionally exposed, such as photocopying machine workers, power-line operators and railwaymen. More abundantly, laboratory studies validated the hypothesis that magnetic fields would induce DNA damage. Genotoxicity studies included detection of Sister Chromatid Exchange (SCE), Chromosomal Aberrations (CA), presence of 8-hydroxy-2'-deoxyguanosine, the alkaline single cell gel electrophoresis (Comet test) and the Micronucleus test. Among genotoxicity assays, one of the most popular is the micronucleus test, because of its simplicity, sensitivity and reliability. Micronuclei are nuclear remains produced during mitosis (or meiosis) when a chromosome fragment or an entire chromosome fails to migrate with one of the two daughter nuclei formed. Basically, this assay consists in the observation of the variations of the frequencies of micronucleated cells. Investigations have been conducted both with *in vitro* and *in vivo* exposure. Several works denied the hypothesis that Extremely Low Frequency (ELF) magnetic fields have genotoxic properties, while other studies have detected positive results only in conditions of co-exposure with other mutagenic agents, such as static magnetic fields, X and gamma rays, benzopyrene, aflatoxine and vinblastine. These results led to the hypothesis that ELF magnetic fields are able to enhance, but not to start, a mutagenic event. This statement could be strengthened when you consider the combined action of ELF and static magnetic fields. In the last years, however, an increasing number of works detected genotoxic properties of ELF magnetic fields, both with *in vivo* and *in vitro* exposure.

Key words: electromagnetic fields, ELF, genotoxicity

Introduction

Genotoxicity describes a deleterious action on a cell's genetic material which affects its integrity. Genotoxic agents, as certain chemicals and some types of radiation, potentially mutagenic or carcinogenic, can cause genetic mutation and contribute to cancer development. The majority of genotoxicity endpoints are structural and numerical chromosome aberrations, assessed using cytogenetic methods, DNA damage (adducts, strand breaks, cross-linking, alkali-labile sites) assessed using biochemical/electrophoretic assays and protein adducts.

Sister Chromatid Exchanges (SCE) are recognized as exchanges of chromosomal fragments between two chromatids of the same chromosome during replication of damaged DNA¹, while Chromosome Aberrations (CA) can be analyzed in cells as structural chromatid- or chromosome-type aberrations, like gaps and breaks within a chromosome or rearrangement within or between chromosomes². The use of fluorescence in situ hybridisation (FISH) chromosome painting methods to detect structural and numerical CAs may provide an increased efficiency and specificity for identifying certain kinds of CAs induced *in vivo*, e.g. translocations, stable symmetrical rearrangements and hyperploidy³.

The micronucleus test⁴ is widely used for detecting cytogenetic damage induced by chemical and physical mutagens. Micronuclei appear when a whole chromosome or a chromosome fragment fails to migrate with one of the two daughter nuclei formed during mitosis. The application of this assay is very popular, in particular on blood samples, as in the latter thousands of scorable cells are present. Moreover, the presence of micronucleated erythrocytes from the peripheral circulation reflects events that occurred in a time equal to the lifespan of the circulating erythrocytes⁵. Therefore, the application of the micronucleus test on peripheral blood samples is particularly indicated for conditions of chronic exposure. Still, the clastogenic or aneugenic origin of the micronuclei cannot be distinguished by conventional microscopic analysis. This can be accomplished detecting the presence or absence of centromere proteins, through immunofluorescent staining with CREST antibodies⁶. This approach, however, does not distinguish between unique chromosomes and may not detect the chromosome loss due to absence of kinetochores on inactive centromeres. The use of FISH to identify centromeric regions is more expensive and laborious but it can provide greater specificity. In particular, centromeric probes for unique chromosomes can be used to detect non-disjunctive events⁷.

Another useful assay is the alkaline single cell gel electrophoresis, also known as Comet test. This is a technique for measuring DNA strand breaks and thereby DNA damage. The assay involves detection, under alkaline conditions, of cell DNA fragments which, on electrophoresis, migrate from the nuclear core, resulting in the formation of the comet tail⁸.

Different frequencies and intensities of electromagnetic fields have been analysed in order to define the genotoxic potential. *In vitro* studies have been conducted at the cellular, molecular and genetic levels. *In vivo* studies have been carried out in vertebrates, invertebrates, plants and bacteria. Taken together, so far the studies have not fully clarified the mechanisms of interaction among electromagnetic waves and living organisms. However, suggestions exist about the genotoxic potential of the magnetic field. Furthermore, the exposure to Extremely Low Frequency Magnetic Fields (ELF-MF) has been correlated with cancer induction, and overall with leukaemia in children⁹.

It was generally accepted that ELF-MF are unable to transfer energy to cells in sufficient amounts to damage DNA directly and thus were considered to be non-genotoxic. However, it is possible that certain cellular processes altered by exposure to ELF-MF, such as free radical production and activity^{10,11} or ion current arising¹²⁻²¹ might indirectly affect the structure of DNA. The combined action with MW evidences alterations in cell functionality due to reduced enzymes activity or modified signalling²²⁻²⁴. In this context, several research groups sought to determine whether a link existed between 50/60 Hz ELF-MF generated by high-voltage power lines or electrical appliances and mutagenesis, and to determine the possible mechanism of cancer risk. Other groups apply the results of these investigations to develop new approaches to therapeutic²⁵⁻³¹ and diagnostic methodics^{32,33}.

Comprehensive reviews regarding *in vivo* and *in vitro* laboratory studies on ELF-MF^{34,35} pointed out the conflicting results reported with genotoxic endpoints such as chromosome aberrations (CA), micronuclei, sister chromatid exchange (SCE), and DNA strand-breakage at exposure levels ranging from 1 μ T to 10 mT³⁶.

In 2002, a comprehensive review of literature was carried out by the International Agency for Research on Cancer (IARC) on the possible health effects of ELF-MF taking into consideration epidemiological reports, animal carcinogenicity data and the outcomes of *in vitro* studies. Rating of exposure to power frequency (50/60 Hz) MF in the 2B category (possible human carcinogen) was proposed.

The research dealing with the genotoxic effects of ELF-MF can be divided between occupational and laboratory exposure, the latter comprising *in vitro* and *in vivo* studies.

Occupational studies

Ciccone *et al.*³⁷ examined the lymphocytes collected from cancer patients with myelodysplastic syndromes, who were occupationally exposed to electromagnetic fields as mechanics or electricians. The data indicated a small but statistically non-significant excess of clonal CA in exposed individuals.

Skyberg *et al.*³⁸ investigated 13 power-line operators who were occupationally exposed to electromagnetic fields during cable testing of DC and AC. These individuals sometimes were exposed to magnetic field of \sim 500 mT (body) and \sim 10.000 mT (hand). During pulse testing, a voltage pulse of up to 2000 kV was suddenly applied to the cable and the peak current during the pulse was about 10.000 A. The data indicated no significant increases in CA and SCE in lymphocytes sampled from individuals exposed to electromagnetic fields. When DNA repair was inhibited by adding hydroxyurea and caffeine to the cell cultures during the final 3 hours of culture period, the mean number of chromosome breaks in electromagnetic fields exposed individuals was significantly higher while chromatid breaks/gaps and chromosome gaps showed only minor differences.

Valjus *et al.*³⁹ examined power line inspectors and maintenance personnel exposed to electromagnetic fields. Several of these individuals were ex-smokers with a short interval between quitting the smoking habit and participation in the study. The results indicated a 2-fold increase in the incidence of chromatid breaks in lymphocytes taken from exposed individuals while no difference was observed in micronuclei and SCE frequencies.

Increases in micronuclei frequencies and chromosomal aberrations have been observed in lymphocytes of photocopying machine workers⁴⁰.

Nordenson *et al.*⁴¹ found significantly higher levels of chromosomal aberrations in train engine drivers compared to train dispatchers, office workers and policemen.

***In vitro* studies**

Garcia-Sagredo *et al.*⁴² used a Magnos stimulator (similar to those used in therapeutic traumatology) to expose human peripheral lymphocytes to 4.4 kHz pulsed electromagnetic fields. It consisted of a rigid plastic device containing Helmholtz coils (64 turns of a 1.3 mm enamel insulated copper wire, 6 cm radius). The results showed no significant increase in the SCE frequency.

In order to expose human lymphocytes and Chinese hamster ovary (CHO) cells, Livingston *et al.*⁴³ used an exposure chamber containing Helmholtz pairs of coils (45 cm long, 8 cm wide, 2 cm height) mounted perpendicular to each other. The larger coils (40 cm diameter) had 111 turns each and spaced 20 cm apart. The smaller coils (30 cm diameter) had 83 turns each and spaced 15 cm apart. The chamber was positioned with the long axis parallel to the axis of the larger set of Helmholtz coils. The investigators found no genotoxic effects, neither in human nor animal cells, but did not indicate the flux intensity of the magnetic field.

Antonopoulos *et al.*⁴⁴ used two different systems in order to expose human lymphocytes to a 5 mT electromagnetic fields. In one case, the electromagnetic fields generated by Helmholtz coils (810 turns of 0.56 mm copper wire, 25 mm inner diameter, 40 mm outer diameter, 60 mm length) was applied parallel to exposure tubes. In the other, the authors used Helmholtz coils (100 turns of 2.5 mm copper wire, 60 cm diameter) where the electromagnetic field was applied perpendicular to exposure tubes. The data indicated that the incidence of SCE was not increased in electromagnetic fields exposed cells.

Galt *et al.*⁴⁵ used Helmholtz coils (16 cm diameter) whose vertical axis was positioned in an incubator to generate sinusoidal magnetic field. The researchers exposed human amniotic cells to a 0.03 mT magnetic field for 72 hours and detected no increase in chromosomes aberrations.

Paile *et al.*⁴⁶ used Helmholtz coils (24 cm diameter) where the sinusoidal magnetic field was generated perpendicular to the plane of the culture dishes containing human lymphocytes. The cells were exposed for 48 and 67 hours to 0.03, 0.3, 1.0 mT magnetic fields. The data showed a significant increase in SCE at 1 mT, but no significant increase in CA and micronuclei.

Maes *et al.*⁴⁷ used a cylindrical exposure unit (380 turn coils, 20 cm inner diameter, 42 cm length) placed inside an incubator to expose human lymphocytes to magnetic field. Different flux densities were used, ranging from 60 to 2500 μ T. No significant effect on chromosome aberrations, sister chromatid exchanges and single-strand breaks. However, the study is difficult to evaluate since the authors did not provide any data and details of the experimental protocol used for the comet assay.

Testa *et al.*⁴⁸ detected an absence of DNA damage in human blood cells exposed *in vitro* for 48 hours to a 50-Hz, 1 mT magnetic field.

Khalil *et al.*⁴⁹ used Helmholtz coils (15x15 cm) placed horizontally in an incubator to expose the human lymphocytes to 1.05 mT pulsed electromagnetic fields. The data indi-

cated no significant increase in the incidence of CA. On the other hand, the frequencies of SCE were significantly increased following 72 hours exposure.

Nordenson *et al.*⁵⁰ used Helmholtz coils (10 turns of copper wire, 15 cm diameter) to expose the human amniotic cells to 0.03 or 0.3 mT homogenous vertical magnetic field either continuously or intermittently. The observations indicated that continuous exposure for 72 hours had no effect on CA, while intermittent exposure resulted in significant increase in CA.

Simko *et al.*⁵¹ used a four-coil electromagnetic fields generator kept in a tissue culture incubator. The data indicated that electromagnetic fields exposure at 0.8 and 1 mT (no increase at 0.1 and 0.5 mT) resulted in a significant increase in micronuclei in transformed cells but not in non-transformed cells. The authors concluded that the SCL II tumour cells are probably more sensitive to indirect effects, leading to the induction of DNA damages to chromosomal segregation failure, supporting the hypothesis that electromagnetic fields have no initiating, but possibly a promoting capacity with respect to their suspected co-carcinogenic competence.

Wolf *et al.*⁵² observed an increase in DNA breakage and formation of 8-hydroxy-2'-deoxyguanosine in leukemic cells HL-60, Rat-1 fibroblasts and WI-38 diploid fibroblasts, after 24 and 72 hours of exposition to 0.5 and 1 mT magnetic fields.

Ivancsits *et al.*⁵³⁻⁵⁵ detected an increase in single and double strand breakage in human fibroblasts intermittently exposed (5' on/ 10' off) to a 50 Hz, 1 mT magnetic field.

Moreover, Pasquini *et al.*⁵⁶ observed an increased frequency of micronuclei in Jurkat cells expose for 24 hours to a 5 mT, 50 Hz magnetic field. Winker *et al.*⁵⁷ detected a time-dependent increase in micronuclei in human diploid fibroblasts, resulting significant after 10 hours of intermittent exposure (5' on/ 10' off) to a magnetic field with a flux density of 1 mT.

Another hypothesis is that electromagnetic fields exposure alone is not genotoxic, but such exposure could enhance the cytogenetic damage induced by other biological, chemical, physical genotoxic agents, that is, it could have an epigenetic or non-genotoxic influence.

Miyakoshi *et al.*⁵⁸ used Helmholtz coils that were kept inside an incubator to expose X-irradiated cells to power frequency magnetic field. The data indicated no significant effect of magnetic field exposure alone, even at 400 mT on SSB. However, an augmentation of X-ray induced SSB was observed when the combined exposure was at higher flux densities of 50 and 400 mT, but not at a lower flux density of 5 mT. Ding *et al.*⁵⁹ found that a 5 mT, 60 Hz magnetic field significantly increased CREST-positive micronuclei in CHO cells after exposure to X-rays.

Another study, conducted on X-irradiated or mytomicin C (MMC) treated mouse m5S cells, detected a significant, dose-dependent increase of chromatid-type chromosomal aberrations at 5, 50 and 400 mT⁶⁰. The authors suggested that "... ELF magnetic field can interfere with post replication repair".

Heredia-Rojas *et al.*⁶¹ used a cylindrical coil (3340 turns of 1.3 mm enamel insulated copper wire, 5.27 cm radius, 25 cm length) to expose the cells to sinusoidal magnetic field and MMC. The data did not indicate increased incidence of SCE in cells exposed to fields alone or its combined exposure with MMC.

Tofani *et al.*⁶² used a pair of Helmholtz coils, which were set perpendicular to each other with their axes lying in the same plane, that is, orthogonal to the ground and pointed towards the magnetic north. One pair of coils was powered with DC while the other pair of coils was powered with both DC and AC. The results of the first experiment indi-

cated no significant increase in micronuclei in human lymphocytes exposed to magnetic field and MMC. The second set of experiments, however, showed a statistically significant increase in micronuclei in cells exposed to magnetic field alone and a synergistic increase in micronuclei following the combined exposure. The authors suggested that "ELF magnetic field does not produce any effect on micronuclei formation unless it is combined with a static magnetic field".

Cho & Chung⁶³ used two identically coupled solenoid coils (350 turns/m of bifilar magnetic wire, 0.15 m diameter, 0.30 m length) to expose the cells to electromagnetic fields and benzopyrene. The data indicated that electromagnetic fields exposure alone had no effect on the incidence of micronuclei and SCE, while its combined exposure with benzopyrene led to a significant increase in micronuclei and SCE in both electromagnetic fields exposed and sham exposed cells.

In order to evaluate the genotoxic potential of 50 Hz magnetic field, Moretti *et al.*⁶⁴ exposed Jürkat cell cultures to 1 mT magnetic field generated by a pair of parallel coils in a Helmholtz configuration for 1 hour. To evaluate the co-genotoxic activity of magnetic fields, benzene, catechol, hydroquinone and 1,2,4-benzenetriol were added to Jürkat cells subcultures at the beginning of the exposure time. In cell cultures co-exposed to magnetic field, benzene and catechol did not show any genotoxic activity. However, co-exposure to magnetic field and hydroquinone or 1,2,4-benzenetriol led to the appearance of a clear genotoxic effect.

Mailhes *et al.*⁶⁵ used Helmholtz coils 1.3 m in diameter to generate 50 mT magnetic field. Virgin female ICR mice were used to examine the effect of ELF exposure on the occurrence of hyperploidy in mouse oocytes induced by vinblastine sulphate. A significant effect on vinblastine sulphate-induced hyperploidy was found, while no effects were detected on the number of oocytes ovulated nor on the occurrence of hypoploidy.

Verheyen *et al.*⁶⁶ used the same exposure system that was used in Maes *et al.*²⁶ to expose human lymphocytes to magnetic field and vinblastine, a chemical that induces unequal segregation of chromosomes leading to the formation of micronuclei. The data indicated that exposure to fields alone had no effect on micronuclei, while an increase in micronuclei frequency was observed in cells exposed to vinblastine and 80 or 800 μ T.

Zmyslony *et al.*⁶⁷ used Helmholtz coils (35 cm diameter) to expose the cells to 7 mT, static or 50 Hz magnetic field and ferrous chloride or H₂O₂. The data indicated that exposure to the fields or ferrous cations alone did not induce significant damage. Combined exposure of ferrous cations and magnetic field resulted in a significant increase in SSB.

In vivo studies

McNamee *et al.*⁶⁸ used Merritt coils (84:36:36:84 turns of copper wire and 40x40 cm square) to expose immature 10 day old animals to magnetic field. Cells from cerebellum region were processed at 0, 2, 4, and 24 hours following 2 hours of exposure to 1 mT magnetic field. The SSB were assessed from comet length, tail length, tail ratio, and tail moment. The data indicated that, except for tail ratio, all the other parameters showed no significant increase in exposed animals.

Lai & Singh⁶⁹ used Helmholtz coils (80 turns of wire with minimum internal dimensions of 0.86x0.54 m) to expose adult rats to 60 Hz magnetic field for 2 hours. Cerebral cells examined at 4 hours after magnetic field exposure, exhibited an increase in SSB at 0.1, 0.25 and 0.5 mT, while DSB were induced at 0.25 and 0.5 mT.

Svedenstål *et al.*⁷⁰, used a vertical sinusoidal, 500 μ T magnetic field to expose adult CBA mice inside a laboratory for 14 days. Cells collected from the front part of the brain cortex exhibited an increase in DSB. Similar results were obtained by Svedenstål *et al.*⁷¹ in an outdoor experiment, when the authors left adult mice in cages under electromagnetic fields generated by the 220kV transmission lines.

Moreover, Lai & Singh demonstrated that treatment of the rats with melatonin or with N-tert-butyl-a-phenylnitron (PBN), immediately before and after magnetic field exposure, avoided the induction of strand breaks⁷², and an increase in DNA-protein and DNA-DNA crosslinks⁷³. The authors concluded that these data suggest that free radicals may play a role in magnetic field-induced DNA damage. This was later confirmed by a similar experiment using Trolox (an analogue of Vitamin E) or 7-nitroindazole (an inhibitor of nitric oxide synthetase). In the same work, by mean of the chelator deferiprone, the involvement of iron was also showed⁷⁴.

Yokus *et al.*⁷⁵ instead, detected a significant increase in 8-hidroxy-2'-deoxyiguanosine (suggestive of oxidative damage to DNA) in plasma of rats exposed to a 970 μ T magnetic field for 50 days.

Huuskonen *et al.*⁷⁶ did not detect any increase in micronucleated erythrocytes sampled from adult mice exposed to a 13 μ T for 18 days.

The same result was obtained by Svedenstål & Johanson⁷⁷ using an exposure system consisting of specially made racks, each consisting of six coil sections arranged like Helmholtz coils (60 cm diameter, 25 cm separation distance). The two end coil sections consisted of three turns of wire while the four inner coil sections were made of two turns of wire each. The coils in two racks were connected to current source and used for vertical exposure. One rack was used for exposure to 50 Hz sinusoidal magnetic field (14 μ T) and another for exposure to 20 kHz saw-tooth-shaped magnetic field (15 μ T). Adult mice were exposed 24h per day for 1, 2, 4, 90 days with no increase in micronucleated erythrocytes.

Abramsson-Zetterberg & Grawé⁷⁸ did not find a significant increase in micronuclei in newborn and adult mice. These were exposed for 21 days (during uterine life for the former) to a 50 Hz, 14 μ T magnetic field and samples were taken 35 days after the end of the exposure.

Fatigoni *et al.*⁷⁹ investigated the genotoxicity of ELF-magnetic field by using the Tradescantia-micronucleus assay. They found that the exposure of Tradescantias to the ELF-magnetic field at a flux density of 1 mT for 1, 6 and 24 hours had a time-dependent increase in the frequency of micronuclei formation.

Erdal *et al.*⁸⁰ acutely (1 day for 4 hours) and chronically (4 h/day for 45 days) exposed Wistar rats to a horizontal 50 Hz, 1 mT uniform magnetic field generated by a Helmholtz coil system. The genotoxic and cytotoxic potential of extremely low frequency magnetic fields was investigated in tibial bone marrow cells, using the chromosomal aberration and micronucleus test systems. In addition, also the mitotic index and the ratio of polychromatic erythrocytes (PCEs) to normochromatic erythrocytes (NCEs) were investigated. The mean micronucleus frequency of the longer-term exposed group was significantly higher than the negative control and acutely exposed groups. The results of the mitotic index in bone marrow showed that the averages of both acutely and chronically exposed groups significantly decreased when compared to those in the negative control. The mean of PCEs/NCEs ratios of acutely exposed group was significantly lower than the negative control and chronically exposed groups. In addition, the group mean of the PCEs/NCEs ratios of chronically exposed was significantly lower than negative control.

In a recent study, Baharara *et al.*⁸¹ exposed Balb/C mice to a 50 Hz, 5 mT magnetic field for 4 days (12 hours/day), finding a significant increase of micronucleated polychromatic erythrocytes.

Our research team, in order to investigate the possible genotoxicity induced by ELF magnetic fields, set up a battery of tests. Four female mice were individually caged and exposed during pregnancy to 50 Hz, 650 μ T magnetic field generated by a solenoid working 24 hours per day, and 38 newborn mice were exposed until day three after birth (for a total of 21 days of exposure), when they were sacrificed. The solenoid was 0.8 m in length and 0.13 m in radius, with 552 turns of 2.5 mm² copper wire, wound in two layers in continuous forward-backward fashion around a cylinder of PVC. Another four female mice were kept unexposed during pregnancy and 36 newborn mice were sacrificed at day 3 after birth. Positive control was carried out exposing five 3-day-old mice to X-rays, which were sacrificed 24 hours later. Moreover, fifteen adult mice were caged in groups of 3 or 4 of the same sex and exposed for 21 days to 50-Hz, 650 μ T magnetic field and sacrificed at the end of the exposure. Another 15 adult mice were kept unexposed for 21 days as controls. Positive control was carried out exposing six adult mice to X-rays, which were sacrificed 24 hours later.

The micronucleus test with CREST antibody staining was performed on liver and peripheral blood sampled from newborn mice and on bone marrow and peripheral blood sampled from adult mice⁸². The percentage of polychromatic erythrocytes in peripheral blood was also assessed, both in adults and newborns⁸³. Furthermore, the Comet test was applied to the brain cells of adult and newborn mice as described by Lai and Singh⁶⁹. Tail Moment, percentage of DNA in the tail and Tail Length were the parameters selected to evaluate DNA damage⁸⁴.

Data obtained in newborn mice show a significant increase in micronuclei frequencies. In absolute terms, most of the induced micronuclei were CREST-negative (i.e., formed by a chromosome fragment). However, in relative terms, ELF exposure caused a two-fold increase in CREST-negative micronuclei and a four-fold increase in CREST-positive micronuclei (i.e., formed by a whole chromosome). No significant increase in micronuclei was recorded on exposed adults. Similarly, a decrease of polychromatic erythrocytes percentage was observed in newborn mice but not in adults. The results obtained with the Comet test showed that exposure to electromagnetic fields caused DNA damage in the brain cells of adult and newborn mice, such damage being significantly higher than in control groups. In addition, the increase of damage due to exposure was higher in newborn mice. DNA damage in the brain cells of young mice after exposure was 4-fold higher than controls, whereas it was 2-fold higher in the adult group. No evidence of cross-links in brain cells following exposure was found in newborn or adult mice.

Conclusions

Several studies have been carried out, both *in vivo* and *in vitro*, to assess the genotoxic potential of ELF magnetic fields. Many studies investigated the possible co-carcinogenic effects, combining magnetic field exposure with other genotoxic agents, both chemical and physical. Positive effects were repeatedly reported, particularly when magnetic field exposure preceded other exposures. These results led to the hypothesis that ELF magnetic field exposure alters biological responses to subsequent exposure to other physical and chemical agents⁸⁵.

However, the number of works which have so far evidenced positive results is nearly equivalent to the amount of those giving negative results. The last years, in particular, showed an increase of works indicating evidence for genotoxic effects caused by exposure to ELF magnetic fields alone^{52, 57, 75, 79-82}, ranging from 30 μ T to 5 mT *in vitro* and from 100 μ T to 5 mT *in vivo*. It should be added that the issue of possible aneugenic effects of electromagnetic fields has been poorly dealt with⁸², despite the growing interest for the link between aneuploidy and carcinogenesis⁸⁶.

The discrepancies between the many studies so far conducted are probably due to the differences in experimental parameters. These comprise physical features (such as frequency and flux intensity), duration and mode of exposure, in addition to characteristics of the cells or animals exposed. Therefore, it is recommended to conduct the same experiment, with the same parameters, in more independent laboratories.

References

1. Latt SA, Allen J, Bloom SE, *et al.* Sister-chromatid exchanges: a report of the GENE-TOX program. *Mutat Res* 1981; 87: 17-62.
2. Carrano AV, Natarajan AT. International Commission for Protection Against Environmental Mutagens and Carcinogens. ICPEMC publication no. 14. Considerations for population monitoring using cytogenetic techniques. *Mutat Res* 1988; 204: 379-406.
3. Albertini RJ, Anderson D, Douglas GR, *et al.* IPCS guidelines for the monitoring of genotoxic effects of carcinogens in humans, International Programme on Chemical Safety. *Mutat Res* 2000; 463: 111-72.
4. Schmid W. The micronucleus test. *Mutat Res* 1975; 31: 9-15.
5. Udrouiu I, Ieradi LA, Cristaldi C, *et al.* Detection of clastogenic and aneugenic damage in newborn rats. *Environ Mol Mutagen* 2006; 47: 320-4.
6. Degrassi F, Tanzarella C. Immunofluorescent staining of kinetochores in micronuclei: a new assay for the detection of the aneuploidy. *Mutat Res* 1988; 203: 339-45.
7. Kirsch-Volders M, Tallon I, Tanzarella C, *et al.* Mitotic non-disjunction as a mechanism for *in vitro* aneuploidy induction by X-rays in primary human cells. *Mutagenesis* 1996; 11: 307-13.
8. Singh NP, McCoy MT, Tice RR, *et al.* A simple technique for quantitation of low levels of DNA damage in individual cells. *Exp Cell Res* 1988; 175: 184-91.
9. Ahlbom A, Day N, Feychting M, *et al.* A pooled analysis of magnetic fields and childhood leukaemia. *Br J Cancer* 2000; 83: 692-8.
10. Brocklehurst B, McLauchlan KA. Free radical mechanism for the effects of environmental electromagnetic fields on biological systems. *Int J Radiat Biol* 1996; 69: 3-24.
11. Seyhan N, Canseven AG. *In vivo* effects of ELF MFs on collagen synthesis, free radical processes, natural antioxidant system, respiratory burst system, immune system activities, and electrolytes in the skin, plasma, spleen, lung, kidney, and brain tissues. *Electromagn Biol Med* 2006; 25: 291-305.
12. Blackman CF, Benane SG, Kinney LS, *et al.* Effects of ELF fields on calcium ion efflux. *Radiat Res* 1982; 6: 510-20.
13. Blackman CF, Benane SG, Rabinowitz JR, *et al.* A role for the magnetic field in the radiation-induced efflux of calcium ions from brain tissue *in vitro*. *Bioelectromagnetics* 1985; 6: 327-37.
14. Liboff AR, McLeod BR. Kinetics of channelized membrane ions in magnetic fields. *Bioelectromagnetics* 1987; 9: 39-51.
15. McLeod BR, Liboff AR, Smith SD. Electromagnetic gating in ion channels. *J Theor Biol* 1992; 158: 15-31.
16. Liboff AR, McLeod BR. Power lines and the geomagnetic field. *Bioelectromagnetics* 1995; 16: 227-30.
17. Vignati M, Giuliani L. Radiofrequencies near high voltage power lines. *Environ Health Perspect* 1997; 105: 1569-74.
18. Zhadin MN, Novikov VV, Barnes FS, *et al.* Combined action of static and alternating magnetic fields on ionic current in aqueous glutamic acid solution. *Bioelectromagnetics* 1998; 19: 41-5.

19. Del Giudice E, Fleischmann M, Preparata G, *et al.* On the 'unreasonable' effects of E.L.F. magnetic fields upon a system of ions. *Bioelectromagnetics* 2002; 23: 522-30.
20. Zhadin M, Giuliani L. Some problems in modern bioelectromagnetics. *Electromagn Biol Med* 2006; 25: 227-43.
21. Giuliani L, Grimaldi S, Lisi A, *et al.* Action of combined magnetic fields on aqueous solution of glutamic acid: the further development of investigations. *Biomagnetic Res Tech* 2008; 6: 1.
22. Marinelli F, La Sala D, Ciccio G, *et al.* Exposure to 900 MHz electromagnetic field induces an unbalance between pro-apoptotic and pro-survival signals in T-lymphoblastoid leukemia CCRF-CEM cells. *J Cell Physiol* 2004; 198: 324-32. Erratum in: *J Cell Physiol* 2004; 198: 479-80.
23. Barteri M, Pala A, Rotella S. Structural and kinetic effects of mobile phone microwaves on acetylcholinesterase activity. *Biophysical chemistry* 2005; 113: 245-53.
24. Gerardi G, De Ninno A, Prosdocimi M, *et al.* Effects of electromagnetic fields of low frequency and low intensity on rat metabolism. *Biomagnetic Res Tech* 2008; 6: 3.
25. Deibert MC, McLeod BR, Liboff AR. Ion resonance electromagnetic field stimulation of fracture healing in rabbits with a fibular osteotomy. *J Orthopaedic Res* 1994; 12: 878-85.
26. Lisi A, Rieti S, Cricenti A, *et al.* ELF non ionizing radiation changes the distribution of the inner chemical functional groups in human epithelial cell (HaCaT) culture. *Electromagnetic Biol Med* 2006; 25: 281-9.
27. Lisi A, Ledda M, De Carlo F, *et al.* Calcium ion cyclotron resonance (ICR) transfers information to living systems: effects on human epithelial cell differentiation. *Electromagnetic Biol Med* 2008; 27: 230-40.
28. Lisi A, Ciotti MT, Ledda M, *et al.* Exposure to 50 Hz electromagnetic radiation promote early maturation and differentiation in newborn rat cerebellar granule neurons. *Bioelectromagnetics* 2005; 24: 532-8.
29. Lisi A, Foletti A, Ledda M, *et al.* Extremely low frequency 7 Hz 100 μ T electromagnetic radiation promotes differentiation in the human epithelial cell line HaCaT. *Electromagnetic Biol Med* 2006; 25: 268-80.
30. Lisi A, Ledda M, Rosola E, *et al.* Extremely low frequency electromagnetic field exposure promotes differentiation of pituitary corticotrope-derived AtT20 D16V cells. *Bioelectromagnetics* 2006; 27: 641-51.
31. Gaetani R, Ledda M, Barile L, *et al.* Differentiation of human adult cardiac stem cells exposed to extremely low frequency electromagnetic fields. *Cardiovasc Res* 2009; 82(3): 385-7.
32. Vedruccio C, Mascia E, Martines V. Ultra high frequency and microwave non-linear interaction device: for cancer detection and tissue characterization, a military research approach to prevent health diseases. *Revue Int. Serv. Santé Forces Armées* 2006; 79: 274-9.
33. De Cicco C, Mariani L, Vedruccio C, *et al.* Clinical application of spectral electromagnetic interaction in breast cancer: diagnostic results of a pilot study. *Tumori* 2006; 92: 207-12.
34. Juutilainen J, Lang S. Genotoxic, carcinogenic and teratogenic effects of electromagnetic fields. Introduction and overview. *Mutat Res* 1997; 387: 165-71.
35. McCann J, Dietrich F, Rafferty C. The genotoxic potential of electric and magnetic fields: an update. *Mutat Res* 1998; 411: 45-86.
36. Villarini M, Moretti M, Scassellati-Sforzolini G, *et al.* Effects of co-exposure to extremely low frequency (50 Hz) magnetic fields and xenobiotics determined in vitro by the alkaline comet assay. *Sci Total Environ* 2006; 361: 208-19.
37. Ciccone G, Mirabelli D, Leis A, *et al.* Myeloid leukemias and myelodysplastic syndromes: chemical exposure, histologic subtype and cytogenetics in a case-control study. *Cancer Genet Cytogenet* 1993; 68: 135-9.
38. Skyberg K, Hansteen IL, Vistnes AI. Chromosome aberrations in lymphocytes of high-voltage laboratory cable splicers exposed to electromagnetic fields. *Scand J Work Environ Health* 1993; 19: 29-34.
39. Valjus J, Norppa H, Jarventaus H. Analysis of chromosomal aberrations, sister chromatid exchanges and micronuclei among power linesmen with long-term exposure to 50-Hz electromagnetic fields. *Radiat Environ Biophys* 1993; 32: 325-36.
40. Irvathy Goud K, Hasan Q, Balakrishna N, *et al.* Genotoxicity evaluation of individuals working with photocopying machines. *Mutat Res* 2004; 563: 151-8.
41. Nordenson I, Mild KH, Jarventaus H, *et al.* Chromosomal aberrations in peripheral lymphocytes of train engine drivers. *Bioelectromagnetics* 2001; 22: 306-15.

42. Garcia-Sagredo JM, Parada LA, Monteagudo JL. Effect on SCE in human chromosomes in vitro of low-level pulsed magnetic field. *Env Mol Mutag* 1990; 16: 185-8.
43. Livingston GK, Witt KL, Gandhi OP, *et al.* Reproductive integrity of mammalian cells exposed to power frequency electromagnetic fields. *Env Mol Mutag* 1991; 17: 49-58.
44. Antonopoulos A, Yang B, Stamm A, *et al.* Cytological effects of 50 Hz electromagnetic fields on human lymphocytes in vitro. *Mutat Res* 1995; 346: 151-7.
45. Galt S, Wahlstrom J, Hamnerius D, *et al.* Study of effects of 50 Hz magnetic fields on chromosome aberrations and the growth-related enzyme ODC in human amniotic cells. *Bioelectrochem Bioenerg* 1995; 36: 1-8.
46. Paile W, Jokela K, Koiviston A, *et al.* Effects of sinusoidal magnetic fields and spark charges on human lymphocytes in vitro. *Bioelectrochem Bioenerg* 1995; 36: 15-22.
47. Maes A, Collier M, Vandoninck S, *et al.* Cytogenetic effects of 50 Hz magnetic fields of different magnetic flux densities. *Bioelectromagnetics* 2000; 21: 589-96.
48. Testa A, Cordelli E, Stronati L, *et al.* Evaluation of genotoxic effect of low level 50 Hz magnetic fields on human blood cells using different cytogenetic assays. *Bioelectromagnetics* 2004; 25: 613-9.
49. Khalil AM, Quasem W, Amoura F. Cytogenetic effects of pulsating electromagnetic field on human lymphocytes in vitro: chromosome aberrations, sister-chromatid exchange and cell kinetics. *Mutat Res* 1991; 247: 141-6.
50. Nordenson I, Mild KH, Andersson G, *et al.* Chromosomal aberrations in human amniotic cells after intermittent exposure to fifty hertz magnetic fields. *Bioelectromagnetics* 1994; 15: 293-301.
51. Simko M, Kriehuber R, Weiss DG, *et al.* Effects of 50 Hz EMF exposure on micronucleus formation and apoptosis in transformed and nontransformed human cell lines. *Bioelectromagnetics* 1998; 19: 85-91.
52. Wolf FI, Torsello A, Tedesco B, *et al.* 50-Hz extremely low frequency electromagnetic fields enhance cell proliferation and DNA damage: Possible involvement of a redox mechanism. *Biochem Biophys Acta* 2005; 1743: 120-9.
53. Ivancsits S, Diem E, Pilger A, *et al.* Induction of DNA strand breaks by intermittent exposure to extremely-low-frequency electromagnetic fields in human diploid fibroblasts. *Mutat Res* 2002; 519: 1-13.
54. Ivancsits S, Diem E, Jahn O, *et al.* Intermittent extremely low frequency electromagnetic fields cause DNA damage in a dose-dependent way. *Int Arch Occ Environ Health* 2003; 76: 431-6.
55. Ivancsits S, Diem E, Jahn O, *et al.* Age-related effects on induction of DNA strand breaks by intermittent exposure to electromagnetic fields. *Mech Age Dev* 2003; 124: 847-50.
56. Pasquini R, Villarini M, Scassellati-Sforzolini G, *et al.* Micronucleus induction in cells co-exposed in vitro to 50 Hz magnetic field and benzene, 1,4-benzenediol (hydroquinone) or 1,2,4-benzenetriol. *Toxicol in vitro* 2003; 17: 581-6.
57. Winker R, Ivancsits S, Pilger A, *et al.* Chromosomal damage in human diploid fibroblasts by intermittent exposure to extremely low-frequency electromagnetic fields. *Mutat Res* 2005; 585: 43-9.
58. Miyakoshi J, Yoshida M, Shibuya K, *et al.* Exposure to strong magnetic fields at power frequency potentiates X-ray induced DNA strand breaks. *J Radiat Res* 2000; 41: 293-302.
59. Ding GR, Nakahara T, Miyakoshi J. Induction of kinetochore-positive and kinetochore-negative micronuclei in CHO cells by ELF magnetic fields and/or X-rays. *Mutagenesis* 2003; 18: 439-43.
60. Yaguchi H, Yoshida M, Ding GR, *et al.* Increased chromatid-type chromosomal aberrations in mouse m5S cells exposed to power-line frequency magnetic fields. *Intern J Radiat Biol* 2000; 76: 1677-84.
61. Heredia-Rojas JA, Rodriguez-De La Fuente AO, Velazco-Campos RM, *et al.* Cytological effects of 60 Hz magnetic fields on human lymphocytes in vitro: sister-chromatid exchanges, cell kinetics and mitotic rate. *Bioelectromagnetics* 2001; 22: 145-9.
62. Tofani S, Ferrara A, Anglesio L, *et al.* Evidence for genotoxic effects of resonant ELF magnetic fields. *Bioelectrochem Bioenerg* 1995; 36: 9-13.
63. Cho YH, Chung HW. The effect of extremely low frequency magnetic fields (ELF-EMF) on the frequency of micronuclei and sister chromatid exchange in human lymphocytes induced by benzo(a)pyrene. *Toxicol Lett* 2003; 143: 37-44.
64. Moretti M, Villarini M, Simonucci S, *et al.* Effects of co-exposure to extremely low frequency (ELF) magnetic fields and benzene or benzene metabolites determined in vitro by the alkaline comet assay. *Toxicol Lett* 2005; 157: 119-28.

65. Mailhes JB, Young D, Marino AA, *et al.* Electromagnetic fields enhance chemically-induced hyperploidy in mammalian oocytes. *Mutagenesis* 1997; 12: 347-51.
66. Verheyen GR, Pauwels G, Verschaeve L, *et al.* Effect of coexposure to 50 Hz magnetic fields and an aneugen on human lymphocytes, determined by the cytokinesis block micronucleus assay. *Bioelectromagnetics* 2003; 24: 160-4.
67. Zmyslony M, Jajte J, Dziubaltowska E, *et al.* DNA damage in rat lymphocytes treated in vitro with iron cations and exposed to 7 mT magnetic fields (static or 50 Hz). *Mutat Res* 2000; 453: 89-96.
68. McNamee JP, Beller PV, McLean JRN, *et al.* DNA damage and apoptosis in the immature mouse cerebellum after acute exposure to a 1 mT, 60 Hz magnetic field. *Mutat Res* 2002; 513: 121-33.
69. Lai H, Singh NP. Acute exposure to a 60 Hz magnetic field increases DNA strand breaks in rat brain cells. *Bioelectromagnetics* 1997; 18: 156-65.
70. Svedenstal BM, Johanson KJ, Hansson Mild K. DNA damage induced in brain cells of CBA mice exposed to magnetic fields. *In Vivo* 1999; 13: 551-2.
71. Svedenstal BM, Johanson KJ, Mattsson MO, *et al.* DNA damage, cell kinetics and ODC activities studied in CBA mice exposed to electromagnetic fields generated by transmission lines. *In Vivo* 1999; 13: 507-13.
72. Lai H, Singh NP. Melatonin and N-tert-butyl-a-phenylnitron block 60-Hz magnetic field-induced DNA single and double strand breaks in rat brain cells. *J Pin Res* 1997; 22: 152-62.
73. Singh NP, Lai H. 60 Hz magnetic field exposure induces DNA crosslinks in rat brain cells. *Mutat Res* 1998; 400: 313-20.
74. Lai H, Singh NP. Magnetic-field – induced DNA strand breaks in brain cells of the rat. *Environ Health Perspect* 2004; 112: 687-94.
75. Yokus B, Cakir D, Akdag MZ, *et al.* Oxidative DNA damage in rats exposed to extremely low frequency electromagnetic fields. *Free Rad Res* 2005; 39: 317-23.
76. Huuskonen H, Juutilainen J, Julkunen A, *et al.* Effects of low-frequency magnetic fields on fetal development in CBA/Ca mice. *Bioelectromagnetics* 1998; 19: 477-85.
77. Svedenstal BM, Johanson KJ. Leukocytes and micronucleated erythrocytes in peripheral blood from mice exposed to 50-Hz or 20-kHz magnetic fields. *Electro Magnetobiol* 1998; 17: 127-43.
78. Abramsson-Zetterberg L, Grawé J. Extended exposure of adult and fetal mice to 50 Hz magnetic field does not increase the incidence of micronuclei in erythrocytes. *Bioelectromagnetics* 2001; 22: 351-7.
79. Fatigoni C, Dominici L, Moretti M, *et al.* Genotoxic effects of extremely low frequency (ELF) magnetic fields (MF) evaluated by the Tradescantia-micronucleus assay. *Environ Toxicol* 2005; 20: 585-91.
80. Erdal N, Gürgül S, Celik A. Cytogenetic effects of extremely low frequency magnetic field on Wistar rat bone marrow. *Mutat Res* 2007; 630: 69-77.
81. Baharara J, Haddad F, Ashraf AR, *et al.* The effect of extremely low frequency electromagnetic field (50Hz) on induction of chromosomal damages on bone marrow erythrocytes of male Balb/C mouse. *J Arak Univ Med Sci* 2008; 11: 19-26.
82. Udroui I, Cristaldi M, Ieradi LA, *et al.* Clastogenicity and aneuploidy in newborn and adult mice exposed to 50 Hz magnetic fields. *Int J Radiat Biol* 2006; 82: 561-7.
83. Cristaldi M, Udroui I, Ieradi LA, *et al.* Genotoxic and hematotoxic damage induced by ELF magnetic fields. *Eur J Oncol* 2009; 13: 239-44.
84. Chiuchiarelli G. Biological effects induced by magnetic field exposure in rodents. Ph.D. Thesis. 2004. Università degli Studi “La Sapienza”, Roma.
85. Juutilainen J. Do electromagnetic fields enhance the effects of environmental carcinogens? *Radiat Prot Dosimetry* 2008; 132: 228-31.
86. Zhang F, Zhao D, Wang S, *et al.* Aneuploidy directly contribute to carcinogenesis by disrupting the asymmetric division of adult stem cells. *Med Hypotheses* 2007; 68: 237-8.

Extremely-low frequency magnetic field modulates differentiation and maturation of human and rat primary and multipotent stem cells

Mario Ledda*, Flavia De Carlo*, Enrico D'Emilia**, Livio Giuliani**, Settimio Grimaldi*, Antonella Lisi*

* Institute of Neurobiology and Molecular Medicine CNR, Rome, Italy

** *** National Institute for Prevention and Safety at Work (ISPEL), Rome, Italy

Abstract

In the last 15 years, we reported numerous biological effects of extremely-low frequency electromagnetic fields (ELF-EMF) on different cells types. We showed morphological and cytoskeletal changes in keratinocyte cell lines exposed to a 50-Hz 2 mT ELF-EMF. Furthermore, we reported that very high magnetic field (MF) intensity promotes maturation and differentiation in newborn cerebellar granule cells, and a 50-Hz 2 mT ELF-EMF produced a sudden increase in the intracellular calcium level in rat anterior pituitary-derived AtT20 D16V cells followed by a reorganization of the cytoskeletal network via polymerization of actin and differentiation of protein expression. Recently, we showed that a combination of static and alternate EMFs, tuned to Ca^{2+} ion cyclotron energy resonance (Ca^{2+} -ICR) was able to trigger human cardiac stem cell-specific differentiation. In the present review, we report a summary of the most relevant results that we have reached in the last 7 years, in particular, we focus the attention on the differentiation effect of ELF-EMF on 3 different types of primary cell culture: human oral keratinocytes (HOK), newborn rat cerebellar granule neurons (CGN), and human adult cardiac stem cells (CSC).

***Key Words:* stem cells, differentiation, ELF-EMF extremely low frequency electromagnetic field**

Introduction

In the last several decades, biology and medicine have made enormous progress in deciphering chemical and mechanical (molecular machines) aspects of cell and molecular biology. The complex picture of the processes in the cell as well as in the tissue was

Address: Mario Ledda, National Research Council INMM Rome Italy - Tel. +390649934230 - E-mail: mario.ledda@artov.inmm.cnr.it

supplemented by recent studies which show a correlation between the presence of electromagnetic field (EMF) gradients and cellular reactions. Such studies arose in embryology, physiology, as well as in molecular biology. Thus, EMF studies in experimental biology and existing EMF therapies in medicine may now have the chance to show the link between clear-cut causal explanations of physics and the observed cellular and organic changes. From experiments dealing with cell/implant surface interactions, it is shown that EMF plays an important role in the cascade of processes determining cell migration, adhesion and differentiation. The experiments also indicate that these forces can now be studied in detail in the micrometer and nanometer scales.

Many studies have shown that EMF can affect cell proliferation and differentiation by influencing the expression of relevant genes and proteins. Depending on the kind of EMF, both stimulation and inhibition of proliferation have been observed. ELF-EMF stimulated embryonic stem cell differentiation into cardiomyocytes by triggering the expression specific cardiac lineage-promoting genes^{1,2}. Similar MF also stimulated proliferation and differentiation of neurons³ and interfered in endorphinergic and cholinergic systems^{4,5}. In contrast, static dc electric field (EF) (2 V/cm) inhibited proliferation of vascular endothelial cells or lens epithelial cells by inducing a cell cycle arrest at the G1/S phase^{6,7}. In both cell types, dc EF significantly decreased the expression of cyclin E, whereas levels of the inhibitor of the cyclin E/Cdk2 complex, p27^{kip1}, increased. Furthermore, the healing of lens epithelial monolayer wounds was inhibited at the cathodal side after exposure to dc EF. Extracellular signal-regulated kinase 1 and 2 activity was increased, but became asymmetrically distributed, with much weaker activity on the cathodal side than on the anodal side^{6,8}. EMF have also been reported to regulate Ca²⁺ homeostasis and influence fracture healing⁹. Studies by Albertini and colleagues¹⁰ have suggested that EMF can prevent or repair damages suffered following heart ischemia-reperfusion injury. The authors found that continuous exposure to a 3 mT 75-Hz pulsed ELF-EMF decreased the amount of permanently injured myocardium after ligation of the left anterior descending coronary artery in rats. Wound-generated endogenous dc EF can control the axis of cell division by orientating mitotic spindles perpendicular towards the field vector⁸. Higher MF densities were also able to orient the cleavage plane during mitosis¹¹ or to distort the mitotic spindle¹².

The hypothetical mechanism to explain the interaction between EMF and biological systems is still debated and is unclear. There is substantial evidence indicating that moderate-intensity static MF are capable of influencing a number of biological processes, particularly those whose function is closely linked to the properties of membrane channels. Most of the reported effects may be explained on the basis of alterations in membrane Ca²⁺ flux⁴. The mechanism suggested to explain these effects is based on the diamagnetic anisotropic properties of membrane phospholipids. It is proposed that reorientation of these molecules during exposure to MF would result in the deformation of imbedded ion channels, thereby altering their dynamics¹³.

Results and discussion

Differentiation of primary human oral keratinocytes induced by EMF

Epithelial cells are an interesting model to study the biological effect of the interaction with non-ionising radiations, because they are directly exposed to the impact of

electromagnetic radiation, and so they are totally available to the field. Primary human keratinocytes cells are also a very good model to investigate the epithelial switch between proliferation and differentiation¹⁵. We analysed the effect of ELF EMF on a primary normal human oral epithelial cell line.

Exposure to a 50-Hz 2 mT ELF EMF resulted in both a decrease in cell proliferation and a reduction of clonogenic capacity in HOK cells (see fig. 1). As compared to unexposed control cells, 96 hours exposure to a 50-Hz MF caused HOK cells to grow at lower rates. It is reported that electromagnetic field exposure can affect keratinocyte proliferation¹⁵. *In addition, our study demonstrates that under conditions of 50-Hz field exposure, HOK cell differentiation is associated with a decrease of proliferation and clonogenic capacity.* On the other hand, experiments performed on DNA extracted from control and exposed HOK cells, revealed that there was no DNA fragmentation in the exposed cells, thus suggesting that the decrease in cellular growth is not due to an apoptosis related process (data not shown). This was also confirmed by SEM images in which apoptotic bodies were never shown. In addition, trypan Blue dye exclusion data demonstrated that the percentage of dead cells was the same in control and exposed HOK cells, and that, as a consequence, the decrease of cell number shown in fig. 1 is not due to cell death, but to a slow-down in the growth rate. By ultramicroscopy (fig. 2I), at 72 hours, exposed cells showed modified morphological changes: they were bigger and more elongated than controls. Exposed cells lost filopodia, and show a higher number of lamellipodia, specialized structures for cell-cell contact. The augment of cell-cell contact junctions is also supported by the increase in expression in beta-catenin as reported in fig. 2II. Beta-catenin is a protein implicated in cell-cell adhesion, binding cytoplasmic domain of cadherin, and in signal transduction. Beta-catenin in 72 hours exposed cells was clearly more dense in spots around the cytoplasm (fig. 2II Panel F), while in non-exposed cells was just visible and distributed throughout the whole cell body (fig. 2II Panel E).

Cell adhesion molecules and their association with actin cytoskeleton play an important role not only in the maintenance of tissue integrity, but also in proliferation and differentiation¹⁶.

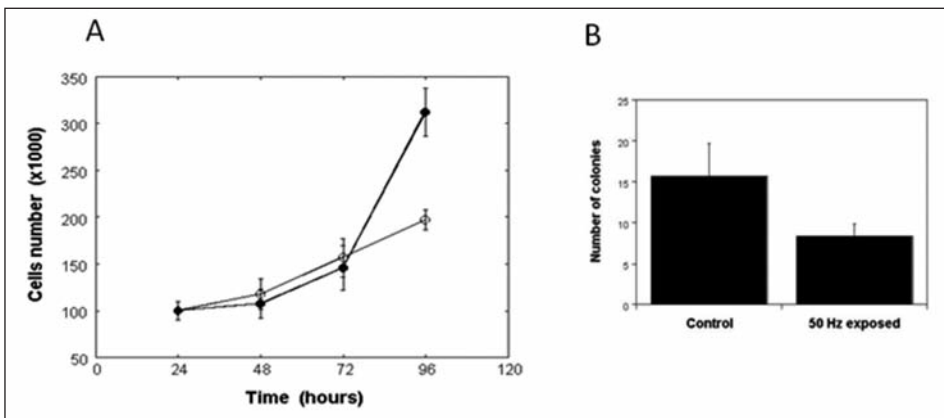

Fig. 1. Effect of exposure to a 50-Hz 2 mT ELF-EMF on HOK cell proliferation and clonogenic capacity. A. Growth curves for HOK control cells (●), and exposed cells (○). B. Clonal Proliferation. Bars show control and exposed HOK colonies production (clonogenic capacity)

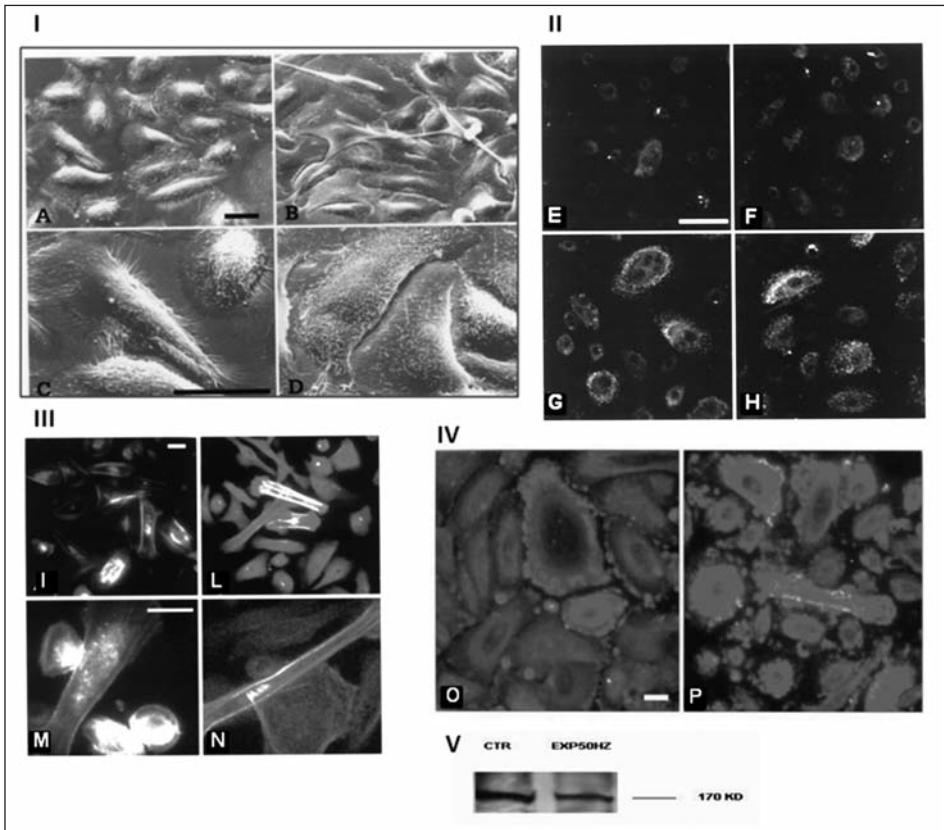

Fig. 2. I. Scanning electron microscopy analysis of control HOK cells (Panels A and C) and exposed cells (Panels B and D), II. Beta-catenin marker analysis by indirect immunofluorescence microscopy in control (Panels E and F) and in exposed cells (Panels G and H), III. Actin confocal microscopy analysis of control (Panels I and M) and exposed cells (Panels L and N), IV. Modulation of involucrin by indirect immunofluorescence in control (Panel O) and in exposed cells (Panel P), V. Western blotting analysis of EGF receptor

Exposure to the field also causes rearranging of actin filaments (fig. 2III), leading to an increase in actin expression and in formation of stress fibres that cross parallel to the elongated cells (fig. 2III Panels L, N).

Since modification of cellular growth rate and gap junction number with the consequent cytoskeleton rearrangement are implicated in cell transformation¹⁷, we analysed the expression of involucrin as a differentiation marker of keratinocytes¹⁸. In human epidermis, involucrin is first observed in the cytoplasm of spinous and granular layer cells. In transition cells, it is equally distributed between the cytoplasm and the nascent corneified envelope, while in the corneocytes it is largely corneified envelope associated. In our experiments involucrin expression in the exposed cells (fig. 2IV Panel P) was increased compared to control (fig. 2IV Panel O). This observation may suggest that the exposed cells are at an upper differentiation level than controls. This is also confirmed by the increase in cell-cell adhesion and by the decrease in cellular growth rate found in exposed samples.

These interpretations also agree with data about the decrease of expression of EGF receptor (fig. 2V). The EGF receptor plays a central role in many aspects of keratinocytes biology²⁰. In normal epidermis, the EGF receptor is important for autocrine growth of this renewing tissue, suppression of terminal differentiation, promotion of cell survival, and regulation of cell migration during epidermal morphogenesis and wound healing¹⁹. We have reported a decrease in expression of EGF receptor in cells exposed to a 50-Hz 2 mT MF for 72 hours, compared to controls. These data confirm that a 50-Hz 2 mT ELF-EMF carries human keratinocytes to an upper differentiation level. This is a very important point suggesting a possible application of ELF-EMF in the therapy of skin proliferative diseases, particularly for diseases in which there is an activation of EGF receptor, such as in psoriasis, where EGF receptor is over expressed in all nucleated strata of epidermis²⁰, or in hyperplasia, hyperkeratosis, papilloma, and squamous cell carcinomas^{20, 21}.

EGF receptor is involved in development of skin neoplasia¹⁹, and recently²², it has been shown that in A431 squamous carcinoma cell line a reduction of EGF receptor expression is related to a decrease in tumor angiogenesis; since in our model we demonstrated an impairment in EGF receptor expression after EMF irradiation, this suggested that it might be possible to use non-ionising radiations to reduce tumor angiogenesis in skin disorders such as hyperplasia, papilloma, and squamous cell carcinomas.

The possibility of using non-ionising EMF for clinical treatments as non-invasive therapeutic agent has just been reported by others²³⁻²⁵.

On the other hand, it should also be considered that the differentiation effect due to EMF exposure on normal epithelial tissues, could represent a cause of tissue premature senescence, as the effect found for ultraviolet radiation^{26, 27}. Moreover, while UV radiation is shielded also by clothes worn, a 50-Hz EMF penetrates into garments and, at the moment, it's not possible to be shielded.

In conclusion, EMF at 2 mT induces an alteration of growth and differentiation pattern on HOK cells, through a decrease of EGF receptor expression. Modifications of morphology, cytoskeletal arrangement, and expression of adhesion and differentiation markers demonstrate that exposed cells are at an upper differentiation level.

If EMF could be used as a therapeutic tool to fight epithelial proliferation diseases, it should be investigate in further studies. At present, we have demonstrated that healthy epithelial tissues chronically exposed to EMF could undergo premature senescence.

EMF promotes maturation and differentiation in newborn rat cerebellar granule neurons

CGN present a good model to study cellular, chemical and electrical properties under EMF exposure conditions. Cerebellar maturation depends on a precise sequence of post-natal events²⁸⁻³⁰, some of which are mediated by glutamate receptors expression and it is differentially regulated during cerebellar development^{28, 31}. The use of EMF, at a wavelength of 800 nm, has been recently reported³² as a noninvasive tool to control a natural biological process such as growth cone of a nerve cell. Brushart and colleagues³³ found that electrical stimulation at 20-Hz promoted motoneuron regeneration, confirming previous findings of the use of electric field for the orientation and growth of neurite³⁴. Control over neuronal growth is an important objective in neuroscience, cell biology, developmental biology, biophysics, and biomedicine and it is particularly important for the formation of neural circuits *in vitro*, as well as nerve regeneration *in vivo*³⁵. We have

found that five days of exposure to ELF (50-Hz) 1 mT EMF induced early glutamate receptor expression in postnatal CGN as shown by a decrease in cells viability from glutamate toxicity test (fig. 3A); indeed, in the presence of glutamate, 30% of exposed cells were expressing the glutamate receptors, while non-exposed cells under the same experimental conditions showed a modest change in cell viability. Challenging the glutamate binding site receptor with a glutamate competitor MK-801, after five days of EMF exposure in plated cells, fully prevented cells from death even in the presence of the neurotransmitter (fig. 3A). The early expression of glutamate receptors in exposed cells is supported by the increase of the kainate-induced currents observed by electrophysiological recordings. The experiments performed on the 6th day (5 days exposed one day rest), cultured CGN showed a significant increase in kainate-induced current (fig. 3B), indicating a bigger conductance in exposed cells with respect to control CGN. This difference in current amplitude in exposed CGN is still noticeable on day 7 and disappeared at 8-day old CGN in culture when compared to control CGN (fig. 3B). The increased current in exposed cells can be interpreted in terms of an early neuronal granule cells maturation and differentiation due to exposure to the EMF. The early expression of glutamate receptor on the exposed CGNs was also established by RT-PCR analysis. It is known that the maximum extent of glutamate receptor mRNAs is normally detectable on the 8th day after plating³⁶; under the same exposure condition to EMF, (50 Hz, 1mT), glutamate receptor mRNAs were evident by RT-PCR after 4 days. In fig. 4A, it is evident that EMF exposure is inducing early and higher mRNA expression for NR-1, Glu-1, Glu-2, Glu-3, and Glu-5, while in the control nonexposed cell, mRNAs maturation for the glutamate receptors is manifest on 8 days only.

Although NR1, Glu1, Glu2, Glu3 and Glu5 receptor mRNAs were detected on day 4 in our exposed primary granule cells culture, NR1, Glu2 and Glu3 receptors were

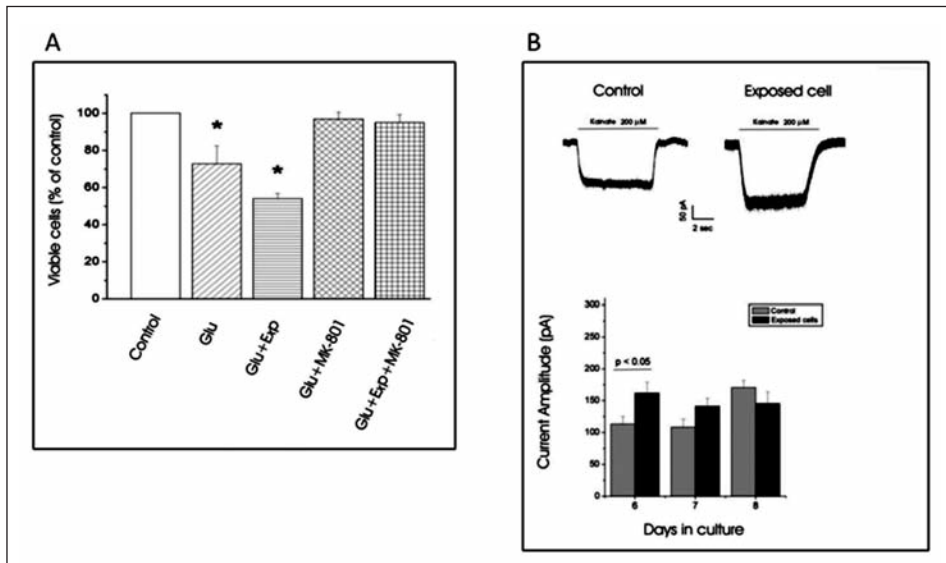

Fig. 3. Glutamate toxicity test and Patch clamp analysis. Effect of 50-Hz 1 mT EMF exposure on: A. glutamate-induced toxicity in cerebellar granule neurons, and B. Kainate-induced currents recorded in cerebellar granule cell in culture

scarcely detected in control cells on day 4 (fig. 4A, lane 3) and Glu-5 started to appear in the control cells on day 5 (fig. 4A, lane 5). Since in nonexposed CGN all the glutamate receptor mRNAs are present at maximum extent after 8 days (fig. 4A, lane 7), this findings may account for an early rate of cell differentiation state induced by EMF exposure. Western blot analysis confirmed the mRNA expression results. High expression of glutamate receptors was detected at 5 days in exposed CGN (fig. 4B, lane 4) with respect to control (fig. 4B, lane 3) and a low proteins expression for Glu2/3 receptors started to appear at 4 days in exposed CGN (fig. 4B, lane 2), reflecting the mRNA levels observed with RT-PCR analysis. The enhancement in the differentiation state induced by EMF exposure is additionally confirmed by indirect immunofluorescence microscopy analysis. Staining cultured neuronal granule cells by monoclonal antibody anti-NF-200 showed, at 5 days in the exposed cells, an increase in neurofilament network growth compared to control at the same time frame (fig. 5A and B). Mature CGN of 8-day-old (positive control) at culture reached the same neurofilament organization as shown in the cells exposed for 5 days (fig. 5B and C). This finding is also confirmed by Western blot analysis of NF-200, as showed in fig. 5D, where the amount of immunoblotted NF-200 in the exposed cells at 5-day culture already reached the same amount found in the control cells at 8 days.

In this study we have shown experimentally the possibility to use EMF at the frequency of 50-Hz to induce early maturation on CGN. It is generally accepted that gradients of physical and chemical factors can be important in determining direction and growth of neurons^{34, 37}. In our experiments cells were exposed both to a weak EF generated together with a magnetic component at 50-Hz, and to an intracytoplasmic very weak electric current induced by the magnetic component. The action of both electric components, across the cell membrane, can affect the membrane potential and consequently could bias ionic conductance, enzyme activity or activating genome sequences. Rapid signalling in neurons requires fast voltage sensitive mechanisms for closing and opening ions channels. Anything that interferes with the membrane voltage can alter channel gating and comparatively small changes in the gating properties of a channel can have profound effects. From a theoretical analysis, King and colleagues³⁸ demonstrated that,

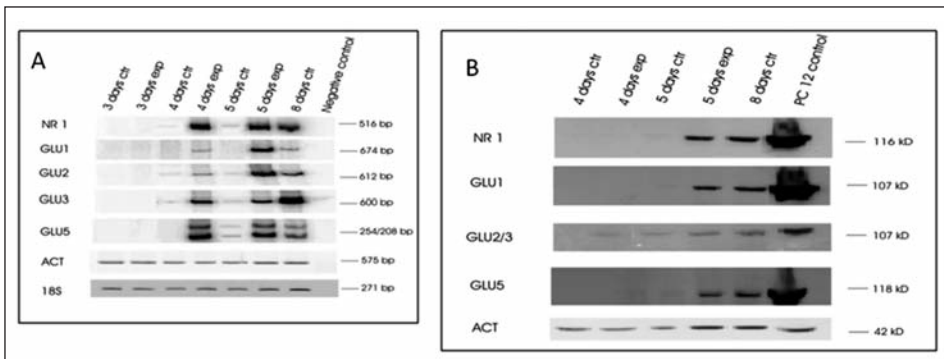

Fig. 4. RT-PCR and Western blotting analysis of GluRs receptors. A. Total mRNA was extracted from control and exposed cerebellar granule neurons at 3, 4 and 5 days. ³²P labelled dAT RT-PCR analysis was used for glutamate receptors detection with specific primers (NR-1, Glu-1, Glu-2, Glu-3 and Glu-5). B. Detection of GluRs receptors from control and exposed cells at 4 and 5 days, respectively. Mature rat cerebellar granule cells (8 days old) and Pc12 cells represent the positive controls

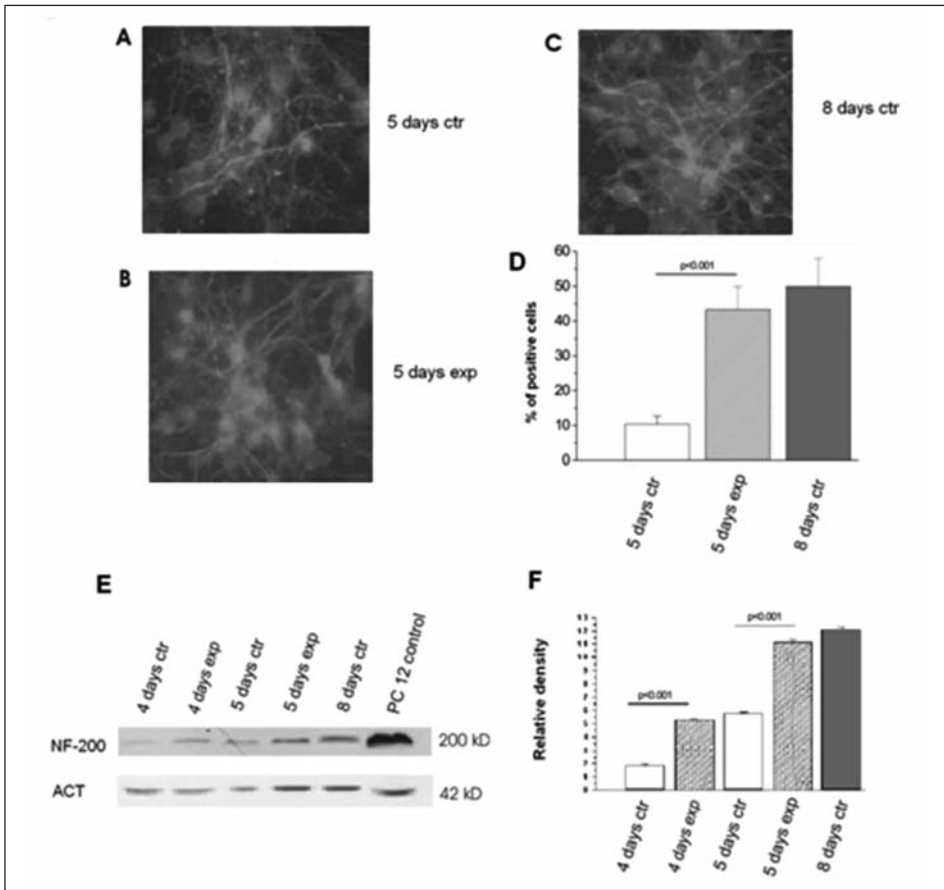

Fig. 5. Immunofluorescence and Western blot neurofilament protein (NF-200) detection. Expression of NF-200 in 5-day control (Panel A), 5-day exposed (Panel B) and 8-day whole mature (non exposed) cells (Panel C). NF-200 variation is reported in the Panel E: Western blot shows an increase in neurofilament protein expression (NF-200) in 4- and 5-day exposed cerebellar granule neurons compared to controls, % of neurofilament positive cells and densitogram analysis of the Western blot are reported in panels D and F, respectively

for perfectly spherical cells, the electric component of an EMF is effectively shielded by the cell membrane, in contrast for a non-spherical shape (which is supposed to have a dimension longer than the other two) the cell membrane has only a partial shielding effect. Since CGN are far from perfect spheres, the electric component of the applied EMF can enter the cells producing microvolt changes in neuronal membrane potential, consequently responsible for a physiological effect. The findings that in exposed cells there is an early expression of mRNAs codifying for glutamate receptors synthesis, as shown in Figure 4, strongly support the hypothesis that the main site of the action of the EF and MF exposure is at the mRNA transcription level.

Granule cells stimulated by exposure to ELF-EMF, develop faster compared to unexposed cells, and undergo more rapid maturation and differentiation processes. The mechanism of the interaction and signal transduction between the physical agent and the

biological target still remains to be understood. Experiments are in progress to define the biochemical pathways of this faster differentiation process at molecular level.

Taken together, our results show the possibility of using electromagnetic stimulation as a co-factor in the treatment of neuronal diseases, as well as in various therapeutic protocols for a non-invasive treatment of peripheral nerve injury.

Differentiation of human adult cardiac stem cells exposed to Extremely-Low Frequency Electromagnetic Fields

We studied the effect of combined static and alternate EMF, tuned at Ca^{2+} -ICR, on a biological system consisting of human CSC. We speculated that suitable combinations of EMF may affect intracellular Ca^{2+} levels, triggering progenitor cells proliferation and differentiation. A number of mechanisms have been postulated for the observed effects of combined MF and EMF. Among them, based on the equation $f = q \cdot \mathbf{B}_{dc} / m \cdot 2\pi$, ICR occurs for predictable combinations of static MF and EMF. Liboff *et al.*¹⁴ suggested that EMF can interact in a resonant manner with endogenous alternate current EF in biological systems. Lednev in 1991³⁹ elaborated a theory to explain ICR at a biological level. He considered an ion in its protein-binding site as a dipole; when the ion is exposed at its ICR, energy is transferred to the dipole and, as a consequence, the ion is released in solution.

Ca^{2+} ions is an essential regulatory component of all organisms. Being a second messenger, Ca^{2+} is involved in regulation at all stages of cellular growth and development, including proliferation, differentiation, assembling and disassembling of cytoskeleton elements⁴⁰⁻⁴⁴.

In our study CSC were exposed for up to 5 days to ELF-EMF close to the ICR frequency corresponding to the charge/mass ratio of the Ca^{2+} ion, on the basis of our previous results obtained with other cellular models^{45, 46}. Exposure to Ca^{2+} -ICR energy produced several effects in CSC. Fig. 6A-I,II show that CSC exposed to ELF-EMF have a higher metabolic activity compared to unexposed cells. This can be related to an increase in cell proliferation, as evidenced by the BrdU incorporation curves (fig. 6A-III, IV). The trend is reduced after 3 days of exposure, perhaps due to both contact inhibition and/or the beginning of the differentiation process, well documented after 5 days in CSC at transcriptional and translational levels. Usually proliferation and differentiation are considered mutually exclusive paths, but since both CSC represent heterogeneous populations of progenitor cells at various stages of commitment, one could expect slightly different responses to proliferative and differentiative stimuli at each intermediate stage. To a certain extent these responses are possibly overlapping in the progressive maturation process of the whole progenitor population.

The increase in mRNA levels of cardiac specific markers, demonstrated by RT-PCR, was associated with an increase in the corresponding protein expression, as evidenced in fig. 6B and fig. 6C. Although CSC spontaneously differentiate towards the cardiogenic phenotype, this process was improved by EMF exposure. The improvement in the differentiation process was cardiac-specific, although not terminal. After Ca^{2+} -ICR exposure, cardiac markers such as TnI, MHC, Cx43 and Nkx2.5 were up-regulated, while vascular markers, such as KDR and SMA, were either unaffected or reduced (fig. 6B, 6C). Cardiac specific differentiation was further evidenced when mRNA levels of cardiac markers (TnI, Nkx2.5 and MHC) of exposed and unexposed cells were compared to those of adult heart tissue from a whole biopsy (data not shown).

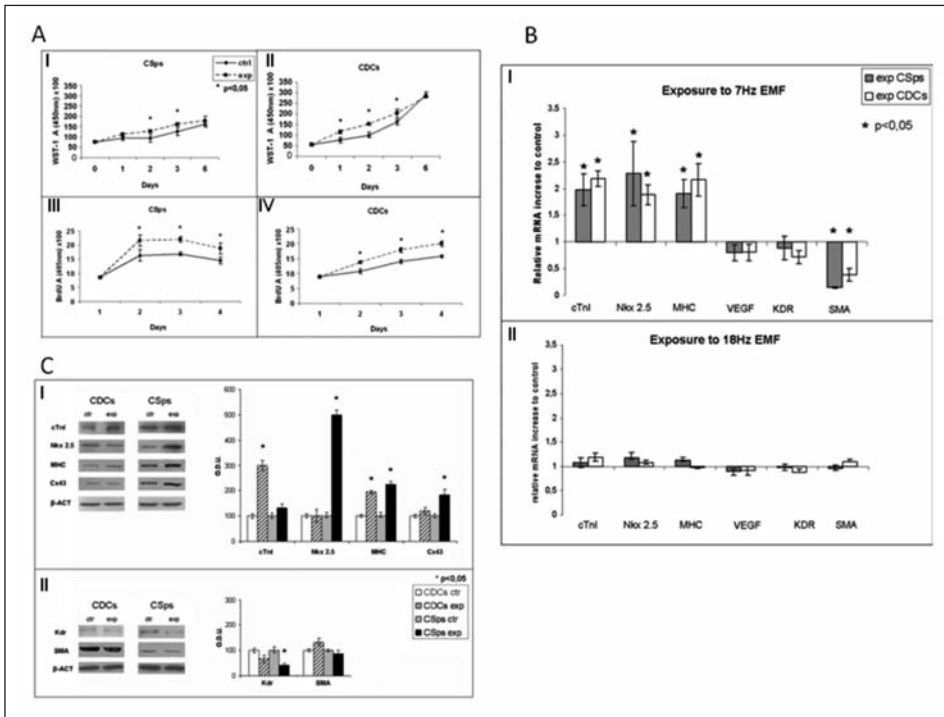

Fig. 6. A. The WST assay and the BrdU pulse-labelling time-course on CSC revealed a higher metabolic activity and a higher proliferation rate in exposed cells compared to unexposed controls. B. CSC exposed to Ca^{2+} -ICR for 5 days revealed a significant increase in relative TnI, Nkx2.5 and MHC mRNA levels by quantitative RT-PCR, C. After 5 days of exposure, CSC showed a significant increase in the expression of cTnI and MHC, or in Nkx2.5, MHC and Cx43, by Western blot analysis

The reduction in expression ratios of heart tissue versus the Ca^{2+} -ICR exposed compared to unexposed samples represents a different and effective plotting option to evidence cardiac differentiation (The meaning of this sentence is not clear). Confocal microscopy analysis (fig. 7A) confirmed an increase in the expression of cardiac markers, as indicated by higher fluorescence intensity for TnI, Cx43, MHC and Nkx2.5. Altogether these results suggest that, in our experimental condition, a lineage specific differentiation is driven by consequence of exposure to Ca^{2+} -ICR.

The same experiments repeated at a frequency not matching ICR of biologically relevant ions, did not display any significant effect at transcriptional level (fig. 6B-II), supporting the hypothesis of a Ca^{2+} -mediated result.

The role of cytosolic Ca^{2+} has long been recognized in the regulation of cellular and molecular interactions. Signal transduction related to Ca^{2+} oscillations can provide molecular cues for cell functions such as differentiation⁴ and proliferation^{47, 48}. Although Ca^{2+} dynamics are versatile and likely to depend on cell type, their role in human CSC differentiation is yet to be fully elucidated.

In the present study, although we did not investigate the involved mechanisms, we unequivocally demonstrated increased intracellular calcium accumulation in CSC after chronic exposure to Ca^{2+} -ICR (data not shown). Furthermore, by compartmentalized

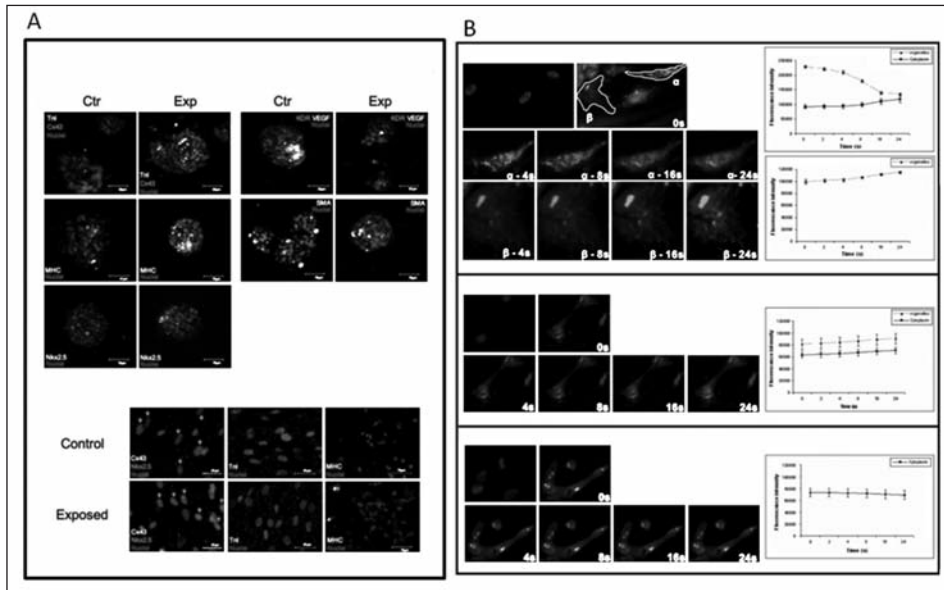

Fig. 7. Confocal images of exposed and unexposed CSC, in CSC cardiac markers, such as Cx43, TnI, MHC and Nkx2.5, were up-regulated compared to controls; conversely expression of vascular markers, such as KDR, VEGF and SMA, was slightly down-regulated or unaffected in exposed CSps vs control, B. Chronically exposed CSC showed Ca²⁺ mobilization from storage compartments to the cytosol (α), and viceversa (β), CSC acutely exposed to Ca²⁺-ICR displayed slight Ca²⁺ mobilization, after chronic exposure for 5 days to the non Ca²⁺-ICR frequency, CSC did not show any Ca²⁺ flux among cytoplasmic compartments. s: seconds

fluorescence analysis through the Ca²⁺ probe Rhod-2, we detected that chronic and acute exposure to Ca²⁺-ICR correlates to Ca²⁺ mobilization among cellular compartments (fig. 7B:). Since Rhod-2 is a mitochondria-specific probe, the mobilization is most likely to be between mitochondria and the cytosol.

In conclusion, in the present experimental strategy, the modulation of both proliferation and cardiac differentiation observed in Ca²⁺-ICR-exposed cells correlates to induced changes in intracellular Ca²⁺ accumulation and mobilization, potentially modulating signal cascade pathways^{4,44}. Independent of the involved mechanisms, the induced differentiation towards the cardiac phenotype has relevant implications for the use of CSC in tissue engineering and cell therapy. The modulation of cell proliferation and specific differentiation elicited by our system through ELF-EMF could represent an effective, non-invasive, simple and safe biotechnological tool to improve cardiac regenerative potential.

References

1. Ventura C, Maioli M, Asara Y, *et al.* Turning on stem cell cardiogenesis with extremely low frequency magnetic fields. *FASEB* 2005; 19: 155-7.
2. Gaetani R, Ledda M, Barile L, *et al.* Differentiation of human adult cardiac stem cells exposed to Extremely Low Frequency Electromagnetic Fields. *Cardiovasc Res* 2009 82(3): 411-20.

3. Arias-Carrion O, Verdugo-Diaz L, Feria-Velasco A, *et al.* Neurogenesis in the subventricular zone following transcranial magnetic field stimulation and nigrostriatal lesions. *J Neurosci Res* 2004; 78: 16-28.
4. Lisi A, Ledda M, Rosola E, *et al.* Extremely low frequency electromagnetic field exposure promotes differentiation of pituitary corticotrope-derived AtT20 D16V cells. *Bioelectromagnetics* 2006; 27: 641-51.
5. Thomas AW, Kavaliers M, Prato FS, *et al.* Pulsed magnetic field induced 'analgesia' in the land snail, *Cepaea nemoralis*, and the effects of mu, delta, and kappa opioid receptor agonists/antagonists. *Peptides* 1997; 18: 703-9.
6. Wang E, Yin Y, Zhao M, *et al.* Physiological electric fields control the G1/S phase cell cycle checkpoint to inhibit endothelial cell proliferation. *FASEB J* 2003; 17: 458-60.
7. Wang E, Reid B, Lois N, *et al.* Electrical inhibition of lens epithelial cell proliferation: an additional factor in secondary cataract? *FASEB J* 2005; 19: 842-4.
8. Song B, Zhao M, Forrester JV, *et al.* Electrical cues regulate the orientation and frequency of cell division and the rate of wound healing in vivo. *Proc Natl Acad Sci USA* 2002; 99: 13577-82.
9. Ibiwoye MO, Powell KA, Grabiner MD, P, *et al.* Bone mass is preserved in a critical-sized osteotomy by low energy pulsed electromagnetic fields as quantitated by in vivo micro-computed tomography. *J Orthop Res* 2004; 22: 1086-93.
10. Albertini A, Zucchini P, Noera G, *et al.* Protective effect of low frequency low energy pulsing electromagnetic fields on acute experimental myocardial infarcts in rats. *Bioelectromagnetics* 1999; 20: 372-7.
11. Valles JM, Jr, Guevorkian K. Low gravity on earth by magnetic levitation of biological material. *J Gravit Physiol* 2002; 9: 11-4.
12. Denegre JM, Valles JM Jr, Lin K, *et al.* Cleavage planes in frog eggs are altered by strong magnetic fields. *Proc Natl Acad Sci USA* 1998; 95: 14729-32.
13. Liboff AR. Electric-field ion cyclotron resonance. *Bioelectromagnetics* 1997; 18: 85-7.
14. Medema JP, Sark MW, Backendorf C, *et al.* Calcium inhibits epidermal growth factor-induced activation of p21ras in human primary keratinocytes. *Mol Cell Biol* 1994; 14: 7078-85.
15. Szabo I, Rojavin MA, Rogers TJ, *et al.* Reactions of keratinocytes to in vitro millimeter wave exposure. *Bioelectromagnetics* 2001; 22: 358-64.
16. Vasioukhin V, Bauer C, Degenstein L, *et al.* Hyperproliferation and defects in epithelial polarity upon conditional ablation of alpha-catenin in skin. *Cell* 2001; 23: 104 (4): 605-17.
17. Hsu M, Andl T, Li G, *et al.* Cadherin repertoire determines partner-specific gap junctional communication during melanoma progression. *J Cell Sci* 2000; 113: 1535-42.
18. Batta K, Rugg EL, Wilson NJ, *et al.* A keratin 14 'knockout' mutation in recessive epidermolysis bullosa simplex resulting in less severe disease. *Br J Dermatol* 2000; 143(3): 621-7.
19. Peus D, Hamacher L, Pittelkow MR. EGF-receptor tyrosine kinase inhibition induces keratinocyte growth arrest and terminal differentiation. *J Invest Derm* 1997; 109: 751-6.
20. Jost M, Kari C, Rodeck U. The EGF receptor-an essential regulator of multiple epidermal functions. *Eur J Dermatol* 2000; 10: 505-10.
21. Dominey AM, Wang, XJ, King L, Jr, *et al.* Targeted over expression of transforming growth factor alpha in the epidermis of transgenic mice elicits hyperplasia, hyperkeratosis, and spontaneous, squamous papillomas. *Cell Growth Differ* 1993; 4: 1071-82.
22. Solomon B, Hagekyriakou J, Trivett MK, *et al.* EGFR blockade with ZD1839 ("IRESSA") potentiates the antitumor effects of single and multiple fractions of ionizing radiation in human A431 squamous cell carcinoma. *Int J Rad Oncol Biol Phys* 2003; 55: 713-23.
23. Basset CAL. Beneficial effects of electromagnetic fields. *J Cell Biochem* 1993; 51: 387-93.
24. Pletnev SD. The use of millimeter band electromagnetic waves in clinical oncology. *Crit Rev Biomed Eng* 2000; 28(3-4): 573-87.
25. Leszczynski D, Pitsillides CM, Pastila RK, *et al.* Laser-beam-triggered microcavitation: a novel method for selective cell destruction *Radiat Res* 2001; 156(4): 399-407.
26. John CF, Morris K, Jordan BR, *et al.* Ultraviolet-B exposure leads to up-regulation of senescence-associated genes in *Arabidopsis thaliana*. *J Exp Bot* 2001; 52(359): 1367-73.
27. Fukunaga M, Oka M, Ichihashi M, *et al.* UV-induced tyrosine phosphorylation of PKC delta and promotion of apoptosis in the HaCaT cell line. *Biochem Biophys Res Commun* 2001; 30: 289 (2): 573-9.

28. Komuro H, Rakic P. Modulation of neuronal migration by NMDA receptor. *Sci* 1993; 260: 95-7.
29. Vignes M, Collingridge GL. The synaptic activation of kainate receptors. *Nature* 1997; 388: 179-82.
30. Mulle C, Sailer A, Perez-Otano I, *et al.* Altered synaptic physiology and reduced susceptibility to kainate-induced seizures in GluR-deficient mice. *Nature* 1998; 392: 601-5.
31. Ripellino JA, Neve RL, Howe JR. Expression and heteromeric interactions of non-N-methyl-D-aspartate glutamate receptor subunits in the developing and adult cerebellum. *Neurosci* 1998; 82: 485-97.
32. Ehrlicher A, Betz T, Stuhmann B, *et al.* Guiding neuronal growth with light. *Proc Natl Acad Sci (USA)* 2002; 99: 16024-8.
33. Brushart MT, Hoffman PN, Royall RM, *et al.* Electrical stimulation promotes motoneuron regeneration without increasing its speed or conditioning the neuron. *J Neurosci* 2002; 22: 6631-8.
34. Patel N, Poo Mu M. Orientation of neurite growth by extracellular electric fields. *J Neurosci* 1982; 2: 483-96.
35. Zeck G, Fromherz P. Noninvasive neuroelectronic interfacing with synaptically connected snail neurons immobilized on a semiconductor chip. *Proc Natl Acad Sci (USA)* 2001; 98: 10457-62.
36. Janssens N, Lesage ASJ. Glutamate receptor subunit expression in primary neuronal and secondary glial cultures. 2001; 77: 1457-74.
37. Jacobson M. *Developmental Neurobiology*, Ed. 2 1978; 157-66, Plenum, New York.
38. King RWP, Wu TT. Electric field induced in cells in the human body when this is exposed to low frequency electric field. *Phys Rev E* 1998; 58: 2363-9
39. Lednev VV. Possible mechanism for the influence of weak magnetic fields on biological systems. *Bioelectromagnetics* 1991; 12: 71-5
40. Nakanishi S, Okazawa M. Membrane potential-regulated Ca²⁺ signalling in development and maturation of mammalian cerebellar granule cells. *J Physiol* 2006; 575: 389-95.
41. Cai H, Liu D, Garcia JG. CaM kinase II-dependent pathophysiological signalling in endothelial cells. *Cardiovasc Res* 2008; 77: 30-4.
42. Means AR. Calcium, calmodulin and cell cycle regulation. *FEBS Lett* 1994; 347: 1-4.
43. Takuwa N, Zhou W, Takuwa Y. Calcium, calmodulin and cell cycle progression. *Cell Signal* 1995; 7: 93-104.
44. Whitfield JF, Boynton AL, MacManus JP, *et al.* The regulation of cell proliferation by calcium and cyclic AMP. *Mol Cell Biochem* 1979; 27: 155-79.
45. Lisi A, Ciotti MT, Ledda M, *et al.* Exposure to 50 Hz electromagnetic radiation promotes early maturation and differentiation in newborn rat cerebellar granule neurons. *J Cell Physiol* 2005; 204: 532-8.
46. Manni V, Lisi A, Pozzi D, *et al.* Effects of extremely low frequency (50 Hz) magnetic field on morphological and biochemical properties of human keratinocytes. *Bioelectromagnetics* 2002; 23: 298-305.
47. Walleczek J, Budinger TF. Pulsed magnetic field effects on calcium signalling in lymphocytes: dependence on cell status and field intensity. *FEBS Lett* 1992; 314: 351-5.
48. Manni V, Lisi A, Rieti S, *et al.* Low electromagnetic field (50 Hz) induces differentiation on primary human oral keratinocytes (HOK). *Bioelectromagnetics* 2004; 25: 118-26.

Immunotropic effects of low-level microwave exposures *in vitro*

Wanda Stankiewicz*, Marek P. Dąbrowski*, Elżbieta Sobiczewska*,
Stanisław Szmigielski*, **

* Military Institute of Hygiene and Epidemiology, Dept of Microwave Safety, 01-163 Warsaw,
Kozielska 4, Poland

** Mazovian Academy, Warsaw, Poland

Abstract

The reasons are presented for which the interest of many investigators is directed to the possible immunotropic influences of low energy microwave (MW) electromagnetic fields (EMFs), in terms of their potential harmful effects and also in the perspective of possible therapeutic applications. The available literature data on the influence of MWs on the immune system are up to now fragmentary, describing the changes of a few immune functions, mainly phagocytosis, lymphocyte proliferation, or antibody production, and are frequently controversial or not confirmed by the results of repeated experiments. On the grounds of results of the two series of own experiments the authors indicate which methodological elements, including precise dosimetric circumstances and the timing of exposure in relation to the cell cycle and the initial functional state of exposed cells may be decisive for the final effect of exposure *in vitro*.

Key words: microwave immunotropic effects, sensitivity of immune cells to MWs, cell cycle, functional state of exposed cells.

Introduction

Rapid development of radiocommunication and radiolocation, and widespread use of different electronic devices (mobile phones, radar and microwave broadcast stations) increase the environmental level of electromagnetic radiation. This, in turn, increased the interest of many investigators on possible pathogenic influences of electromagnetic emitters and, on the other hand, on the potential of their therapeutical applications.

After 30 years of research into this area, there is still insufficient information on the specific biological influence of nonthermal intensity of electromagnetic fields (EMFs)¹. According to WHO Environmental Health Criteria WHO², nonthermal inten-

Address: Prof. dr med. Stanisław Szmigielski, Military Institute of Hygiene and Epidemiology, 01-163 Warsaw, Kozielska 4, Poland - E-mail: szmigielski@wihe.waw.pl

sities of microwaves (MW) are presently recognized as a “weak factor of biological influence”. This imprecise description has initiated searches for biological detectors sensitive enough to measure “weak biological influence” of MWs, and one of main candidates is the immune system, which is able to react in a measurable way to discrete environmental stimuli. As an important part of homeostatic neuroendocrine-immune network of the organism, the immune system is responsible for efficient defense against infections, regenerative support for injured tissues, and maintenance of immune tolerance toward self or foreign but neutral elements³⁻⁵. These different reactions of the immune system can be investigated using *in vitro* or *in vivo* tests to evaluate possible influences of external stimuli (e.g., drugs or physicochemical factors). Available data on the influence of MWs on the immune system are fragmentary, report on changes of few immune functions, mainly phagocytosis, lymphocyte proliferation, or antibody production, and are frequently controversial or not confirmed by the results of repeated experiments⁶⁻⁹.

Some authors¹⁰ conclude that studies of MW-exposed immune cells have shown no damage or change until the cells were heated, while others¹¹⁻¹³ report immunosuppressive or immunostimulatory phenomena in animals with long-term exposure to low-level MW fields.

Depending on conditions of exposure, frequency and modulation of the radiation, as well as on animal species used in the experiments, various symptoms of either stimulation or inhibition of certain immune reactions have been reported. Guy *et al.*¹⁴ in the lifetime exposure of rats to MWs (pulsed 2450 MHz, SAR 0.15 - 0.4 W/kg) found lowered response of blood lymphocytes to mitogen phytohaemagglutinin (PHA), while Śmiałowicz¹⁵ after exposure at the same wave frequency, although at higher power intensities (SAR 1 – 5 W/kg) reported increased mitogenic response of lymphocytes. Investigating the humoral immune response in mice exposed to 9.4 GHz at SAR 0.015 W/kg, depending on the carrier wave modulation, Vayert *et al.*⁹ found enhancement or lowering the response.

Even the epidemiological investigations of workers exposed to MW radiation did not confirm the existence of measurable shift in the immune status of the investigated populations, despite some observations on abnormalities in single immune parameters in several individuals (e.g. changed number of blood lymphocytes, lowered level of serum immunoglobulins or weaker response of lymphocytes to mitogens). In the available literature no reports exist on the complex assessment of immune phenomena under EMF influence, all investigations were aimed to evaluate only selected, fragmentary reactions of the system or selected types of immune cells. At the present state of knowledge it is, therefore, not possible to conclude about the specific immunotropic potencies of MW radiation, as the assessment of the immunotropic potency requires a general insight into the whole complex immune network, taking in advance the determination of immune status of the host or the investigated cellular population prior to the MW exposure.

The final effect of exposition of biological material to MW radiation depends on the physical properties of applied electromagnetic field on the one side, and on the functional state of exposed living target on the other. The EMFs used in different experiments may differ in countless dosimetric elements, including wave length and frequency, pulse modulation, intensity of EMF influencing the degree of specific absorption rate (SAR) and duration of the exposure. The functional characteristics of biological material, e.g. blood mononuclear cells mainly used for *in vitro* studies, is

even more complex. The EMF exposure may affect the cell at different levels of its structure: the surface receptors changing their distribution and conformation, the cellular membrane changing its rigidity and permeability, mitochondrial metabolic activity, transcription and translation processes or several of these elements at different intensities.

The mononuclear cells isolated from peripheral blood remain in their most stable and inert metabolic state, the G0 phase of cell cycle, in which the cell represents low sensitivity to external influence^{16,17}. When the cell cultured *in vitro* enter more active phases of cell cycle (G1, S, G2, M), its sensitivity to EMF influence may change significantly. In these circumstances the cells exposed to EMF after isolation from the blood, like in the most published studies *in vitro*, and after that cultured, specifically stimulated and tested for their different activities, may not display any significant changes. The exposition to EMF during the culture, of already activated cells, although methodically much more difficult, may deliver better insight into the potential immunotropic effects of the exposition.

One of the best methods of evaluation of immunotropic influences of EMF administered *in vitro* is the system of microcultures of mononuclear cells isolated from the blood (PBMC), representing *in vitro* the abilities of the immune system *in vivo*. The advantages of the method are accessibility of human cells, donor safety, and wide repertoire of immune tests which can be performed.

Recently, using these methods, we investigated the behavior of PBMC in a microculture system after exposure to pulsed (5 μ sec pulses) 1300MHz microwaves (10W/m², SAR 0.18W/kg)¹⁸. The exposure resulted in the increased immunoregulatory activity of T cells, increased production of IL-10, increased IL-1 production by monocytes, and decreased concentration of IL-1ra in culture medium. We concluded that MW may support the inductive phase of immune response, increasing the activity of monocytes and T cells. The special feature of this experiment was that cells were exposed to EMF before the culture, indicating that at the time of exposure they remained metabolically neutral (G⁰ phase of cell cycle), which is normal for lymphocytes freshly isolated from blood.

In the *in vivo* situation, the accidental or deliberate exposure of the individual to MW may influence neutral or active immune cells, both normally present in the body. We have questioned how the active cells, e.g., stimulated *in vitro* with mitogens and entering G1 and S phases, will react to the subsequent exposure to MW. To evaluate the problem, a special anechoic chamber was constructed and technically tested in the Department of Microwave Safety, Military Institute of Hygiene and Epidemiology in Warsaw, Poland¹⁹. The chamber, containing the microplate with cultured cells and MW-emitting antenna, was installed inside the ASSAB CO2 incubator so the PBMC could be exposed to MW at different periods of culturing without removing them from the incubator.

The miniature anechoic chamber (MAC) was a cube of 40 × 40 × 40cm of external dimensions. The internal walls of the chamber were covered by pyramid absorbers to guarantee the absorption of incident field only by the samples. MW reflected from absorbers could be neglected. The absorbers also protected the test samples from the radiation reflected from metal walls of incubator and maintained the homogeneity of MW field around the samples inside the chamber. The plate with cultured cells was located in the middle part of chamber, while the mobile handset used as a MW-emitting antenna was placed on the floor of chamber. The internal dimensions of the chamber were 23 × 23 × 23 cm.

Experiment I. Immunotropic influence of 900 MHz microwave GSM signal on human blood immune cells activated in vitro

Blood samples were collected by vein puncture from healthy donors. PBMC were isolated on Ficol-Paque gradient, and after determination of cell viability (usually no less than 80% viable cells), the microcultures were set up in triplicates (10^5 cells/0.2 ml RPMI + 15% autologous inactivated serum) in Nunclon microplates. Respective triplicates were left without stimulation or stimulated with phytohemagglutinin (PHA, HA16, Murex Biotech Ltd Dartford U.K., 0.4 μ g/cult.) or with concanavalin A (Con A, Sigma, 8 μ g/cult.). The plates were placed inside the anechoic chamber in the ASSAB incubator at 37°C and 5% CO₂. An identical plate of control cultures was also set up and placed in the ASSAB incubator beyond the chamber. At 24h of incubation, rearrangements of the cultures were performed as described elsewhere^{18,20,21}.

As a result of rearrangements of cultures performed at 24 h, the following parameters of T cell and monocyte activities were measured at the end of cultures: T lymphocyte response to PHA and to Con A, saturation of IL-2 receptors, T cell suppressive activity (SAT index), and the index of monocyte immunogenic activity (LM) related to the ratio of produced monokines (IL-1 β versus IL-1ra)²⁰.

For the last 18h of incubation, ³H-labelled-thymidine (³HTdR, Amersham, U.K., spec act. 5 Ci/mM) was added into the cultures in a dose of 0.4 μ Ci/cult.

At the beginning of each of the three consecutive days of incubation, the cultures placed in the anechoic chamber were exposed to MW (900MHz, 20V/m, SAR 0.024W/kg) for 15 min. Control cultures were not exposed to MW.

At 72h the cultures were harvested and incorporation of ³HTdR was measured in Packard Tri carb 2100 TR scintillation counter. The results were calculated as a mean value of dpm (desintegrations per minute) per triplicate of cultures \pm SD. The experiments were repeated 10 times, and the results observed in the exposed cultures were compared with those obtained in the control cultures. The data were analyzed with STATGRAPHICS PLUS 4.0 version (Nr. 471000349). The differences between the mean values were assumed statistically significant if the p values, calculated with the use of U Mann-Whitney's test, were lower than 0.05.

Results and discussion

The relatively short time of exposure of cultured cells to MW (15 min, administered repeatedly at the beginning of each of the three consecutive days of culturing) was chosen deliberately. First, our intention was to check the effects of exposure similar in duration to the average use of a mobile phone. Second, the cells, stimulated with mitogens, were exposed immediately after entering the G1 phase of cell cycle (first day exposure), again when the majority of cells responding to mitogen entered the S phase (second day exposure), and finally when the responding cells, after replication of DNA, reached stage G2 and mitosis (third day exposure). In this way the repeated exposures to MW covered the main periods of metabolic activity during the cell cycle of cultured cells^{16,19}.

The results of 10 experiments are presented in Table 1. The data obtained indicate that activity of lymphocytes and monocytes tested in vitro increased significantly under the influence of MW administered during the culture. The proliferative response of T lymphocytes exposed to MW increased from the value of 60.7 to 82.8 dpm in response to PHA ($p < 0.001$) and from the value of 55.9 to 73.8 dpm in response to Con A

Table 1 - Influence of MW (900 MHz) on the activity of T lymphocytes and monocytes in microcultures

Cultures (N = 10)	Tested parameter				
	Response to PHA dpm x 10 ³ /cult	Response to Con A dpm x 10 ³ /cult	Saturation of IL-2 receptors (%)	T cell suppressive T activity SAT (%)	LM index
Control	60.7 ± 18.7	55.9 ± 18.3	85 ± 3	36 ± 2	8 ± 2
Exposed to MW	↑ 82.8 ± 26.2	↑ 73.8 ± 25.7	84 ± 2	34 ± 2	↑ 18 ± 3
Statistical significance	p < 0.001	p < 0.001	p = 0.3920	p = 0.0964	p < 0.001

($p < 0.001$). The exposure to MW also increased the immunogenic activity of monocytes. The value of LM index, which depends on the ratio of IL-1 β to IL-1ra²⁰, (both monokines produced by monocytes), increased from the value 8.0 to the value 18.0 ($p < 0.001$). In contrast to the suppressive activity index (SAT), which represents regulatory function of T cells, the saturation of T lymphocyte receptors with interleukin 2 did not change under the influence of exposure to 900 MHz MWs.

The experiments presented here show for the first time that human lymphocytes and monocytes, induced in culture into active phases of their cell cycle (G1 in terms of monocytes and G1 and S in terms of T cells), further accelerate their metabolic activity under additional stimulus created by the exposure to 900 MHz GMS signal.

In contrast to the *in vitro* conditions, where freshly isolated PBMC remain in G0 phase, the immune cells of living organism represent all possible stages of cell cycle. To mimic *in vitro* the *in vivo* situation, we have used for our experiments the anechoic chamber installed in the ASSAB incubator. This technique opens the way to evaluate the possible influence of EMF on different phases of the cell cycle of immune cells. Our observations suggest that a 900 MHz GSM signal is immunostimulatory and may increase the immune reaction of lymphocytes and monocytes already participating in the immune response.

Testing possible immunotropic influences of 900 MHz GSM signal on human blood lymphocytes Scarfi *et al.*²² did not find any changes in proliferative rate of cells exposed for 24 hour before setting up the cultures. Similar timing of exposure (irradiation before the culturing) was applied for human lymphocytes by Tuschi *et al.*²³. They found no changes in several cytokine production and cytotoxic potential of lymphocytes exposed to 1950 MHz, SAR 1 mW/g. The both groups of authors conclude that tested radiofrequencies did not evoke any adverse influences on human immune cells. Nevertheless, in the light of cited above our experiments, the improper timing of irradiation could be responsible for observed negative results.

Experiment II. Immunotropic influence of 1300 MHz MW on cultures of blood mononuclear cells derived from normal donors or patients suffering from chronic virus B hepatitis.

The effect of irradiation may also be dependent on the initial immune state of the donor of blood lymphocytes. Two groups of blood donors, one of healthy individuals

(HD) and the other of patients suffering from chronic virus B hepatitis (HV) were enrolled into our experiments in which blood lymphocytes were exposed to 1300 MHz pulse modulated microwaves at 330 pps with 5 μs pulse width, or left without irradiation²⁴. The specific absorption rate (SAR) was measured and the value of SAR = 0.18 W/kg was recorded. The microcultures of PBMC were subsequently set up to determine several parameters characterizing the T cell immunocompetence and monocyte immunogenic activity, including: proliferative response to mitogens (PHA, Con A), saturation of IL-2 receptors, T cell suppressive activity (SAT index), monocyte immunogenic activity (LM index) and production of chosen cytokines.

Results

The same power density of 1 mW/cm² reduced response to PHA in HD cultures and significantly increased this response in HV cultures, increased values of SAT and saturation of IL-2 receptors in the both HD and HV cultures (Table 2) and significantly increased production of interferon gamma (IFNγ) and production of tumor necrosis factor alpha (TNFγ) in the HV cultures but not in the HD cultures (Table 3). The results suggest that microwave irradiation (1300 MHz, pulse modulated) may exert distinct immunotropic influence and may enhance the effector immune response in patients with chronic virus B hepatitis, including considerable stimulation of the production IFNγ by immune cells.

Conclusion

The presented data suggest, that exposition in vitro of human blood mononuclear cells to different radiofrequencies of low energy MW (e.g. 900 and 1300 MHz) is potent to modulate the immune activity of lymphocytes and monocytes. The range of affected

Table 2 - Immunomodulatory effects in PBMC cultures exposed to EMF

Test	HD cultures		HV cultures		Statistical significance
	control	EMF exposed	control	EMF exposed	
Spontaneous ³ HTdR incorp.(dpm x 10 ³)	1.9 ± 0.6	1.6 ± 0.2	2.9 ± 0.7	↓ 1.8 ± 0.3	HDc/HVc p< 0.01 HVc/e p< 0.01
Response to PHA (dpm x 10 ³)	67.1 ± 8.7	↓ 45.8 ± 13.7	75.8 ± 9.8	↑ 98.2 ± 13.7	HDc/e p< 0.01 HVc/e p<0.05
Response to Con A (dpm x 10 ³)	37.2 ± 11.7	46.9 ± 2.8	40.2 ± 16.8	47.7 ± 2.4	HDc/e NS HVc/e NS
SAT index	11.7 ± 9.4	↑ 29.7 ± 7.3	19.8 ± 11.4	↑ 28.9 ± 11.8	HDc/e p< 0.01 HVc/e p< 0.05
Saturation of IL-2 receptors	72.3 ± 4.6	↑ 91.1 ± 11.1	72.1 ± 7.6	↑ 87.1 ± 10.4	HDc/e p< 0.01 HVc/e p< 0.01
LM index	5.7 ± 3.1	7.6 ± 4.2	9.7 ± 4.2	↑ 19.7 ± 8.2	HDc/e NS HVc/e p< 0.01

HD: cultures of PBMC from healthy donors, HV: cultures of PBMC from patients with chronic virus B hepatitis.

Table 3 - Cytokine production in control and EMF exposed PBMC cultures (pg/ml)

Cytokines	HD cultures		HV cultures		Statistical significance
	control	EMF exposed	control	EMF exposed	
IL-1 β	287 \pm 120	298 \pm 189	510 \pm 212	741 \pm 259	HDc/e NS HVc/e p< 0.05
IL-1ra	1312 \pm 692	↓ 670 \pm 256	2312 \pm 672	2670 \pm 1456	HDc/e p< 0.01 HVc/e NS
IFN γ	630 \pm 92	510 \pm 118	673 \pm 92	↑ 1367 \pm 847	HDc/e NS HVc/e p< 0.01
TNF α	1987 \pm 986	2421 \pm 475	1983 \pm 936	↑ 3425 \pm 875	HDc/e NS HVc/e p< 0.01
IL-10	311 \pm 123	↑ 623 \pm 193	471 \pm 149	↓ 166 \pm 59	HDc/e p< 0.01 HVc/e p< 0.01

HD: cultures of PBMC from healthy donors, HV: cultures of PBMC from patients with chronic virus B hepatitis

immune parameters depend not only on the wave length, frequency and intensity of EMF but also on the timing of exposures (before or during the culture) and on the initial immune status of the donor of immune cell.

References

1. Stavoulakis P. Biological Effects of Electromagnetic Fields. New York: Springer; 2003.
2. WHO/INIRC. Environmental Health Criteria No. 137, Electromagnetic Fields (300 Hz–300 GHz). Geneva: WHO; 1993.
3. Besedovsky H, Sorkin E. Network of immune-endocrine interactions. Clin Exp Immunol 1977; 21: 1-12.
4. Deschaux P, Kahn NA. Immunophysiology: the immune system as a multifunctional physiological unit. Cell Mol Biol Res 1995; 41: 1-17.
5. Hadden JW. Neuroendocrine modulation of the thymus-dependent immune system. Ann NY Acad Sci 1987; 496: 39-58.
6. Fesenko EE, Makar VR, Novoselova EG, *et al.* Microwave and cellular immunity. I. Effect of whole body microwave irradiation on tumor necrosis factor production in mouse cells. Bioelectrochem Bioenerg 1999; 49: 29-35.
7. Huang ATF, Mold NG. Immunologic and haematopoietic alterations by 2450 MHz electromagnetic radiation. Bioelectromagnetics 1980; 1: 77-85.
8. Rama Rao G, Cain CA, Tompkins WAF. Effects of microwave exposure on the hamster immune system. Bioelectromagnetics 2000; 21: 265-72.
9. Veyert B, Bouthet C, Deschaux P, *et al.* Antibody response of mice exposed to low-power microwaves under combined pulse and amplitude modulation. Bioelectromagnetics 1991; 112: 47-56.
10. Black DR, Heynick LN. Radiofrequency (RF) effects on blood cells, cardiac, endocrine and immunologic functions. Bioelectromagnetics 2003; suppl. 6: 187-95.
11. Lushnikov KV, Gapeev AB, Sadovnikov VB, *et al.* Effects of extremely high frequency electromagnetic radiation of low intensity on parameters of humoral immunity in healthy mice. Biofizika 2001; 46: 753-60 (in Russian).

12. Lushnikov KV, Gapeev AB, Shumilina IV, *et al.* Decrease in the intensity of the cellular immune response and non-specific inflammation upon exposure to extremely high frequency electromagnetic radiation. *Biofizika* 2003; 48: 918-25 (in Russian).
13. Makar V, Logani M, Szabo I, *et al.* Effect of millimeter waves on cyclophosphamide-induced suppression of T cell function. *Bioelectromagnetics* 2003; 24: 356-65.
14. Guy AW, Wallace J, McDougall JA. Circularly polarized 2,450 MHz waveguide system for chronic exposure of small animals to microwaves. *Radio Sci* 1979; 14 (6S): 63-74.
15. Śmiałowicz RJ. Haematologic and immunologic effects. In: Elder JA, Cahill DF. *Biological Effects of Radiofrequency Radiation*. US EPA Report 1984; 600/8-83-026F; 5-28.
16. Dąbrowski MP, Goldstein AL. Thymosin induced changes in the cell cycle of lymphocytes from aging neonatally thymectomized rats. *Immunol Communic* 1976; 5: 695-704.
17. Janossy G, Graves MF. Lymphocyte activation. II. Discriminating stimulation of lymphocyte subpopulations by phytomitogens and heterologous antilymphocyte sera. *Clin Exp Immunol* 1972; 10: 525-34.
18. Dąbrowski MP, Stankiewicz W, Kubacki R, *et al.* Immunotropic effects in cultured human blood mononuclear cells pre-exposed to low level 1300MHz pulse-modulated microwave field. *Electromagn Biol Med* 2003; 22: 1-13.
19. Stankiewicz W, Dąbrowski MP, Kubacki R, *et al.* Immunotropic influence of 900 MHz microwave GSM signal on human blood immune cells activated in vitro. *Electromagn Biol Med* 2006; 25: 45-51.
20. Dąbrowski MP, Dabrowska-Bernstein BK, Stasiak A, *et al.* Immunologic and clinical evaluation of multiple sclerosis patients treated with corticosteroids and/or calf thymic hormones. *Ann NY Acad Sci* 1987; 496: 697-706.
21. Dąbrowski MP, Stankiewicz W, Plusa T, *et al.* Competition of IL-1 and IL-1ra determines lymphocyte response to delayed stimulation with PHA. *Mediators of Inflamm* 2001; 10: 101-7.
22. Scarfi MR, Fresegna AM, Villani P, *et al.* Exposure to radiofrequency radiation (900 MHz, GSM signal) does not affect micronucleus frequency and cell proliferation in human peripheral blood lymphocytes; an interlaboratory study. *Radiat Res* 2006; 165: 655-63.
23. Tuschi H, Novak W, Molla-Djafari H, *et al.* In vitro effects of GSM modulated radiofrequency fields on human immune cells. *Bioelectromagnetics* 2006; 27: 188-96.
24. Stankiewicz W, Dąbrowski MP, Jabłkowski M, *et al.* Immunotropic influence of pulse modulated 1300 MHz microwaves on cultures of lymphocytes and monocytes isolated from the blood of patients with chronic virus B hepatitis. *Centr Eur Journ Immunol* 2006; 31: 36-9.

Cellular enzymatic activity and free radical formation in various tissues under static and ELF electric and magnetic field exposure

Nesrin Seyhan*, **, Ayse G. Canseven*, **, Goknur Guler*, **, Arin Tomruk*, Arzu Firlarer**

* Gazi University, Faculty of Medicine, Department of Biophysics

** Gazi Non-Ionizing Radiation Protection Center – GNRP, Ankara, Turkey

Abstract

Biological effects of static electric and 50-Hz electric (E) and magnetic (B) fields with intensities similar to occupational exposure have been analyzed at the Bioelectromagnetic Laboratory of Biophysics Department in the Medical Faculty of Gazi University for more than 25 years. A principal aim of this review is to evaluate the results of our *in vivo* studies. Static electric field in the range of 0.3-1.9 kV/m (0.3, 0.6, 0.8, 0.9, 1.35, 1.8, 1.9 kV/m) and ELF electric field in the range of 1.35-12 kV/m (1.35, 2, 2.5, 3, 3.5, 4, 4.5, 5, 12 kV/m) were applied to lab animals, directions (vertical and horizontal) and exposure periods (4-8 h/day, for 1, 3, 5, 7, 10 days). ELF magnetic fields were also applied with intensities of 1, 1.5, 2, and 3 mT. Magnetic field exposure periods were 4 h/day for 4, 5 or 7 days and 8 h/day for 5 days. Under the above exposure conditions, cellular enzymatic activities (SOD, GSH-Px, MPO, CAT, ADA and XO) and free radicals (MDA and NOx) were analyzed in the plasma, serum and in the tissues of skin, liver, lung, kidney, brain, spleen and testis. Plasma and brain electrolytes such as Na⁺, Ca⁺⁺, Mg⁺⁺, Zn⁺⁺ and K⁺ were also studied. Natural Killer cell activity and hydroxyproline content were examined in the skin, brain, lung, spleen and testis tissues under ELF electric and magnetic fields. In addition, Genetic Programming and Neural Network of those tissues were also studied. The results of this study indicated that the changes in lipid peroxidation level (TBARS) and antioxidant enzyme activity (SOD) induced by 50 Hz E-field exposure are higher than those induced by static field. Cellular alterations induced by electromagnetic fields may influence the biochemical reactions in the cell, changing both biochemical parameters and enzyme activities in serum. Our *in vivo* studies showed that biological responses of plasma and serum were observed to be differentiated under 50 Hz E-field. We observed that 50 Hz ELF E-field seems to be more effective on plasma than on serum. Power frequency (50 Hz/60 Hz) magnetic fields (MFs) can also affect biological systems by activating secondary chemicals such as radicals. ELF EMF has been thought to prolong the life of free radicals and can act

as a promoter or co-promoter of cancer. Therefore, ELF MF was classified as a “possible human carcinogen” by The International Agency for Research on Cancer- IARC. In the study, the changes in free radical levels (MDA, NO), antioxidant enzymes (GSH, MPO) and in electrolytes concentrations of various tissues (brain, heart, lung, liver, kidney, plasma) were observed under 50 Hz magnetic fields exposure in different exposure durations. In the light of our results, it can be interpreted that magnitude and exposure durations of electric and magnetic fields may play crucial role in both formation of free radicals and biochemical reactions mediated by free radicals within tissues.

Key words: Static Electric Field, ELF Electric Field, Magnetic Field, free radicals, antioxidant enzymes, electrolytes, hydroxyproline, Natural Killer cell, *in vivo* EMF.

Introduction

There are numerous sources of ELF-EM fields such as high voltage transmission lines, residential power distribution lines, transit systems, electrical appliances, tools and machines used in houses, offices, and various industry and public places¹. With the widespread use of these man-made EM sources, human exposure to ELF-EM fields increased significantly during the last century. A large number of experiments have been carried out and many theories have been proposed to reveal the interaction mechanism of ELF-EM radiation with biological systems. *In vivo* studies in the literature reported that EM field exposure causes adverse bio-effects on tumor incidence, reproduction and development, and neuronal and behavioral activities. Results of some epidemiological studies on occupational/residential exposure to magnetic (B) and electric (E) fields have linked to increased rates of certain cancers²⁻¹¹. Proposed mechanisms of weak-field bio-effects include chemical kinetic effects, stochastic resonance, electrically induced phase transitions, radical pair reactions, cyclotron resonance, resonant transport of ions, coherence effects, signal averaging rectification, parametric resonance, ion interference, coherent excitations, alterations of metastable water states, and effects of torsion fields. Furthermore, scientists have also proposed that ELF magnetic fields interact with electron currents that flow through the stacked bases within DNA¹²⁻¹⁵.

Some of the studies have reported that EM field exposure can cause changes in radical homeostasis leading to an increment in the levels of free radicals¹⁶⁻¹⁹ and increase of RNA, DNA and protein synthesis²⁰⁻²². Most of those studies are focused on the effects of ELF B-field, whereas number of studies on the effects of ELF E-field is limited. Besides, it is not yet known that whether ELF E-field has an impact on the biological responses to oxidative stress²³.

Oxygen and nitrogen free radicals, namely reactive oxygen species (ROS) and reactive nitrogen (RNS) species are the products of normal cellular metabolism. ROS and RNS are well recognized for playing a dual role as both harmful and beneficial to living systems²⁴. Oxidative stress is mediated by both attacks of ROS/RNS and imbalance between free radicals and antioxidant defense mechanisms. Furthermore, it increases the cellular levels of oxidatively modified proteins, lipids and nucleic acids, leading to a decrease of physiological functions and metabolic integrity²⁵.

The bio-effects of Static and ELF E & B-fields have been investigated for more than 20 years in the Bioelectromagnetic Laboratory at Gazi Biophysics Department. In this review, *in vivo* effects of exposure to static and ELF E & B-fields of different intensities and directions and at different duration on different tissues are discussed.

Materials and methods

Static & ELF E-field exposure systems

Static, vertical and horizontal ELF E-field were applied to animals in plexiglass cages using 2 different exposure setups with dimensions of 50 x 50 x 14 cm and 80 x 80 x 18 cm. The copper plates spacing were 14 cm or 18 cm, and the dimensions of the plates were 50 x 50 x 0.1 cm and 80 x 80 x 0.2 cm, respectively, for the two spacing conditions.

For vertical field exposures, copper plates were mounted on the top and bottom of the cage (fig. 1). For horizontal field exposures, copper plates were mounted on two sides of the holding cage (fig. 2). For vertical ELF E-field exposure, positive probe of the power supply was always connected to the upper plate and negative probe to the lower plate, while one of the plates was positive and the other one was negative for horizontal exposure (figs. 1-2).

The potential differences were kept constant with the aid of a demonstrative voltage display through a 3 digit LED of power supply (TETA T-994 DC&AC, Navelsan, Ankara, Turkey). Also, a multi-meter connected to the circuit was used to double-check the level of potential difference between the parallel plates. Magnitude of electric field on the cages of animals was determined by not only theoretical calculation, but also measured with an NARDA EFA-300 E-field probe (NARDA, Pfullingen, Germany).

Static E-field in the range of 0.3-1.9 kV/m (0.3, 0.6, 0.8, 0.9, 1.35, 1.8, 1.9 kV/m) and 50-Hz ELF E-field in the range of 1.35-12 kV/m (1.35, 2, 2.5, 3, 3.5, 4, 4.5, 5, 12

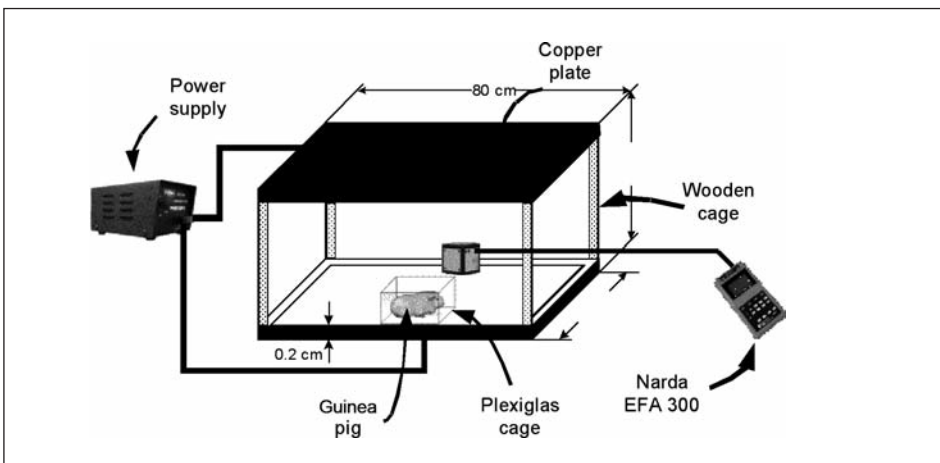

Fig. 1. Vertical electric field exposure system

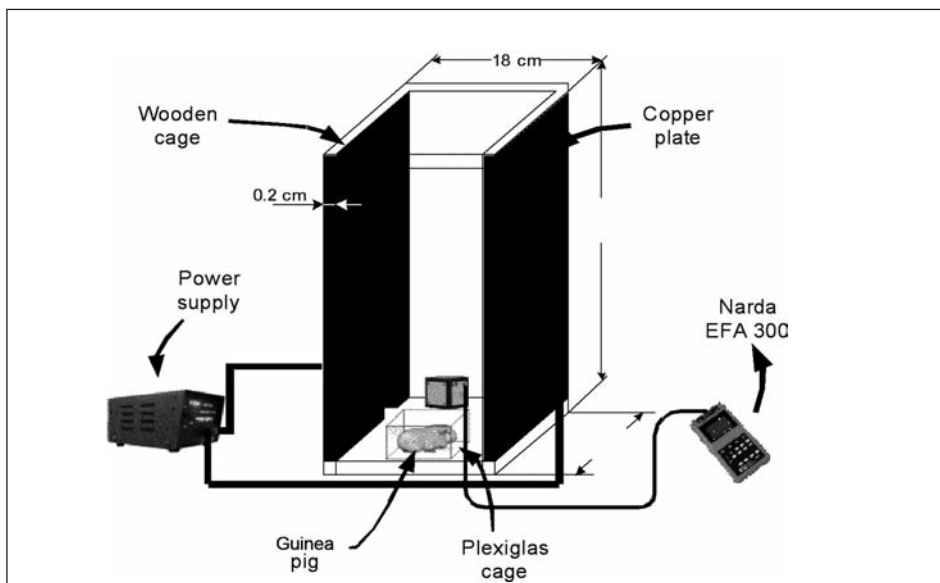

Fig. 2. Horizontal electric field exposure system

kV/m) were applied to Guinea pigs in order to evaluate the biological effects induced by different intensities, directions (vertical and horizontal) and exposure periods (4-8 h/day for 1, 3, 5, 7, 10 days). Since placing more than one animal in a cage would create a stress factor, only one animal was placed per cage during E-field exposure. After the last day of exposure, brain, lung, kidney, liver, spleen, testis, skin from each animal were removed and rinsed out with ice-cold buffered saline. Dissociation of serum and plasma were performed. All tissues were instantaneously placed in liquid nitrogen and stored at -85°C until the biochemical assay procedure. All the tissues were analyzed for:

- Tissue hydroxyproline content²⁶;
- Malondialdehyde (MDA), or in other words, Thiobarbituric Acid Reactive Substances (TBARS)^{27,28};
- Nitric Oxide (NO)^{29,30};
- Glutathione Peroxidase (GSH-Px)³¹;
- Superoxide Dismutase (SOD)^{32,33};
- Myeloperoxidase (MPO)³⁴;
- Catalase (CAT)³⁵;
- Xanthine Oxidase (XO)³⁶;
- Adenosine deaminase (ADA)³⁷.

Changes in lipid peroxidation and antioxidant enzyme levels in spleen and testis under both static and ELF E-fields were also analyzed by the neural network. Tissues from animals exposed to 50-Hz, 1.35 kV/m E-field for 8 h/day for 1, 3, 5, 7 or 10 days and static E-field at intensities of 0.3, 0.6, 0.8, 0.9, 1, 1.35, 1.5, 1.8 or 1.9 kV/m with daily exposure of 8 h/day for 3 days were analyzed. The experimental results were applied to neural networks as learning data and the training of the feed forward neural network was realized³⁸.

Effects of 50-Hz 1.35 kV/m E-field exposure for different periods (2, 4, 6, 8, 11 days) and static E-field exposure (0.2, 0.4, 0.7, 0.85, 1.2, 1.4, 1.6, 1.75 and 2.2 kV/m for 8 h/day for 3 days) were analyzed by means of the back propagation hybrid genetic algorithm and neural network (GANN) techniques³⁹.

Experimental protocols were reviewed and approved by the Laboratory Animal Care Committee of Gazi University.

Magnetic field exposure system

The B-field exposure system was circular Helmholtz coils which were developed at the Gazi Bioelectromagnetic Laboratory⁴⁰ (fig. 3).

Guinea pigs and mice were exposed to B-fields in polycarbonate cages (26 x 22 x 10 cm). The cages were positioned at the center of the coils in order to avoid the distorted field which may occur at the edges.

ELF B-Fields were applied to the subjects in order to assess the induced biological effects with flux densities of 1, 1.5, 2, and 3 mT. Exposure periods were 4 h/day for 4, 5 or 7 days and 8h/day for 5 days.

After the last day of exposure, brain, lung, kidney, liver, spleen, skin were removed from each animal and rinsed out with ice-cold buffered saline. They were instantaneously placed in liquid nitrogen and stored at -85°C until the biochemical assay procedure. All the tissues were analyzed for:



Fig. 3. Magnetic Field Exposure System

- Tissue hydroxyproline content⁴¹;
- Malondialdehyde (MDA)²⁸;
- Nitric Oxide (NO)^{29,30};
- Glutathione (GSH)⁴²;
- Myeloperoxidase activity (MPO)⁴³;
- Plasma and brain electrolytes of Na, Ca, Mg, Zn and K;
- Natural Killer cell activity⁴⁴.

All experimental protocols were reviewed and approved by the Laboratory Animal Care Committee of Gazi University.

Results and conclusion

Electric field studies

1) Electric fields - collagen synthesis study

Collagen is the major structural protein in the extracellular matrix, making up about one-third of the protein mass in higher animals. This protein family plays a dominant role in maintaining the structure of various tissues and also has many other important functions involving cell adhesion, chemotaxis, migration and regulating tissues remodeling during growth, differentiation, morphogenesis and wound healing, and in many pathologic states^{45,46}. Hydroxyproline, a modified proline with a hydroxyl moiety, is present in a variety of structural proteins, predominantly in collagen⁴⁷. The rate of hydroxyproline formation is therefore considered to be a good indication of the rate of collagen biosynthesis.

Exposure to horizontal and vertical E-field of 0.9 kV/m is found decreased the level of hydroxyproline in the liver, lung and kidney tissues. On the other hand, 1.9 kV/m E-field exposures increased hydroxyproline in the same tissues. Vertical E-fields exposure - both 0.9 kV/m and 1.9 kV/m - is found to be more effective than horizontal field^{48,49}.

2) Electric fields - free radicals and antioxidant enzymes (MDA, NO, SOD, CAT, GSH-Px, XO, MPO and ADA)

Free radicals, generated in cells by ELF EM field, are an important area of research⁵⁰⁻⁵². By taking into account the important role of the radicals in vital biological reactions, we analyzed the formation of free radicals under ELF E-field exposure. We found significant differences between MDA and SOD contents in spleen and testis of the exposed and unexposed subjects. All tissue levels of MDA and SOD were proportionally increased with the applied E-field intensity^{38,53,54}. We have hypothesized that increment of free radicals within cells and the transformation of molecular O₂ to free radicals O₂^{·-} may be related to an increase in the energy of E-field.

Significant increase in the TBARS level and SOD activity of plasma, liver, lung, and kidney tissues were also observed. In both vertical and horizontal applications, increase for TBARS level started at 0.8 kV/m for plasma, 1 kV/m for liver and kidney, and 1.35 kV/m for lung tissue. On the other hand, for SOD activity, increase started at 0.8 kV/m for plasma and at 1 kV/m for liver, lung, and kidney tissue for both field directions. At 0.8 kV/m, both SOD activity and TBARS level were observed increased in plasma whereas the threshold for liver and kidney was at 1 kV/m and at 1.35 kV/m for lung^{55,56}.

Recent epidemiological and experimental studies reported that the majority of ELF EM exposure compose of electric fields in different directions, strengths and periods in the range of several kV/m generated from power lines that are constructed near residential area⁵⁷⁻⁵⁹.

It was also investigated whether E-fields generated by power lines can modify oxidant-antioxidant formation under both vertical and horizontal applications of ELF E- fields at different intensities (1.35, 2, 2.5, 3, 3.5, 4, 4.5, 5 kV/m for 8 h/day) for different exposure periods (1, 3, 5, 7, 10 days) in the brain, liver, lung, kidney, serum and plasma of guinea pigs^{55,60,61}. Plasma TBARS level and SOD activity increased in the subjects exposed to 50-Hz 1.35 kV/m E-field for the duration of one day or more. We found that 3, 5, 7, and 10 days of exposure made both parameters increase even further. No significant differences were found in plasma SOD activity in between the exposure groups of 3–5 days, 3–7 days, and 5–7 days while the differences in between the other periods of exposure were significant. Increments in TBARS level and SOD activity in liver, lung, and kidney tissues started on the 3rd day of exposure and continued with more exposure periods. TBARS level and SOD activity were found to increase under exposure of both horizontal and vertical E fields with the strength of 1 kV/m in liver, lung and kidney. However, increment of these levels began with 0.8 kV/m for plasma and 1.35 kV/m for serum. Different exposure periods (1, 3, 5, 7, 10 days) of 1.35 kV/m E-field were applied. The significant increase in TBARS and SOD level was started in the 3rd day of exposure in liver, lung and kidney tissues, which may be denotes as threshold period for exposure to 1.35 kV/m. On the other hand, one day exposure to 1.35 kV/m E-field was enough to cause increase in plasma⁵⁵.

Both vertical and horizontal E-field of 0.3, 1, 1.35, 1.5 and 1.8 kV/m increased the TBARS level and SOD activity. It was found that 1.35 kV/m was the threshold level for both of the parameters analyzed. Increments in the levels of other blood parameters (total cholesterol, LDL, HDL, VLDL, total protein albumin, GGT, ALT, ALP, LDH, urea, uric acid, glucose, creatine and BUN) were found to be statistically insignificant⁶⁰.

The E-field strengths under power lines are in the range of 1–5 kV/m, and may reach 10kV/m for a few transmission lines⁶². Occupational exposures of some workers, e.g. in substations, may reach to the high levels of E-fields between 1–20 kV/m⁶³. For this reason, we applied 50-Hz E-fields in the ranges of 2-5 kV/m to the subjects. No differences were found in MDA contents and antioxidant enzyme activities (SOD, CAT, GSH-Px, XO, MPO and ADA) of brain. Influence of E-fields on the brain might have been reduced by the skull which is a good dielectric material⁶¹.

We have also investigated whether exogenous antioxidant treatments have any observable protective effect against residential exposure to power lines. Individual and combined N-acetyl-L-cysteine (NAC, 300 mg/kg) and epigallocatechin-gallate (EGCG, 25mg/kg) were applied to subjects at 30 min before E-field exposure (50-Hz 12 kV/m in vertical direction) for 7 days²³. NAC has been widely used in the clinic for the treatment of hepatic failure due to acetaminophen overdose. It has also been shown to be effective at reducing toxin and stress-induced cellular necrosis^{64,65}. NAC regulates redox status in cells since it can act as a precursor of L-cysteine and reduced glutathione (GSH). NAC is an important antioxidant as it is a direct ROS and RNS scavenger by providing sulphhydryl groups^{66,67}. EGCG is the major polyphenolic constituent found in green tea and in dried fresh leaves of the plant *Camellia sinensis L.*⁶⁸. Most of the therapeutic benefits of green tea are due to the catechins, which are polyphenols with a flavanoid structure⁶⁹.

We observed that ELF E Field (50 Hz 12 kV/m) have boosting effects on free radical formation (MDA and NO) and attenuator effects on the activities of hepatic antioxidant enzymes (SOD, GSH-Px, MPO). In this study, the individual or combined application of NAC and EGCG led to decrease in the oxidative stress of liver tissue²³. It has also been proposed that moderate levels of ROS can induce an increase in antioxidant enzyme activities, whereas very high levels of these reactants decreased the activities of antioxidant enzymes⁷⁰. Hepatic antioxidant enzymes might be suppressed because of the high levels of radical production and oxidative inactivation of enzyme protein.

In lung, while oxidized protein (PCO) were found to increase, no changes were observed in radical levels (MDA, NO), hydroxyproline (HP) content and hemeoxygenase (HO-1) activity of exposed group with respect to unexposed groups⁷¹.

Evaluation of human exposure to E-fields is much more difficult than to B-fields, because of the E-field perturbation by the human body and other objects and frequently the measuring device⁷². In this view, studies on the interaction of surrounding E- fields with tissue are limited. More research is warranted on the interaction of surrounding E-fields with tissue.

Determination of effects of E-field on tissues by using a computer is predicted by neural network without applying E-fields into tissues. The prediction of the hybrid genetic algorithm and neural network approach is on average 99.25% -99.99%^{38, 39}.

Magnetic field studies

Due to increased use of electricity, people are exposed to intermittent and chronic exposure to ELF EM fields of various intensities and forms. Recent studies have demonstrated that the incidence of certain types of cancer, such as leukemia and brain cancer might be induced and increased due to 50-Hz B-field exposure⁷³⁻⁷⁶. Therefore, the International Agency for Research on Cancer (IARC) has classified ELF B-fields as possibly carcinogenic to humans (2B)⁷⁷. EM fields may affect biomolecular synthesis in cells, the metabolism of carbohydrates, protein and nucleic acids, the kinetics of DNA, RNA and protein production and membrane permeability⁷⁸⁻⁸¹.

Some *in vivo* studies on ELF B-fields performed at the Gazi Biophysics Laboratory are described in this paper. These studies dealt with analysis of B-field effects on skin collagen synthesis, free radicals (MDA, NO, GSH, MPO), electrolytes and Natural Killer (NK) cells in different tissues such as brain, liver, heart, lung, kidney, skin, plasma and serum. Our genetic programming and neural network modeling studies are also summarized.

1) Magnetic fields and skin collagen synthesis

Nearly half of the body's collagen is in the skin and 9-13% of collagen is composed of HP⁸². Therefore, collagen synthesis could be investigated by determining the HP content of the skin^{83, 84}.

Collagen, which has piezoelectric characteristics, could be affected from external and/or internal natural B-fields due to its electrical charges. Collagen, in the skin, serves as a first target of the external EMFs. It was investigated whether ELF B-fields may affect skin collagen synthesis with exposure to 50-Hz B-fields of 1, 2 or 3 mT for 5 days. Daily exposure periods were 4 hours and 8 hours. HP levels in the skin decreased by 1 mT for 4 h/day for 5 days, but increased by 2 mT and 3 mT for both of the experimental exposure periods

(4 h/day and 8 h/day for 5 days). Alterations in HP levels were found to be more pronounced for 2 mT in the periods of 4 hours, and for 3 mT in the exposure periods of 8 hours with respect to other groups⁸⁴⁻⁸⁶. More research is needed in this area.

It is shown that observed effects of B-field can be defined as a window effect with respect to field intensities. Window effect dependence on field intensity might be further investigated.

2) Magnetic fields and free radicals (MDA, NO, GSH, MPO) and electrolytes

It has been suggested that 50/60 Hz B-fields may prolong the lifetime of free radicals and increase their concentration in living cells^{87,88}. One of the biochemical reactions of free radicals is lipid peroxidation, induced by free radicals, which is probably the most extensively investigated process. Peroxidation of fatty acids in lipids may lead to radical chain reactions. Because of these chain reactions, one substrate radical may result in the formation of many equivalents of lipid peroxides. These degenerative propagation reactions in lipid membranes are usually accompanied by the formation of a wide variety of products such as MDA. Products resulting from lipid peroxidation are thus attractive parameters to monitor radical damage^{89,90}.

Another free radical parameter is nitric oxide (NO). Some evidence suggests that NO may act as an antioxidant. Also, it may interact with superoxide anion and other radicals to produce less toxic species. In contrast, other evidence suggests that NO may interact with reactive oxygen intermediates to form more toxic species. The reaction of NO with a superoxide anion can produce the peroxyxynitrite anion, which can decompose to generate a strong oxidant with reactivity similar to that of a hydroxyl radical. Peroxyxynitrite can induce sulfhydryl oxidation and lipid peroxidation⁹¹.

Antioxidant activity of living cells may be affected by exposure to B-fields of various frequencies and intensities. Increment in the production of GSH is an indicator of the activation of cell defense mechanism against oxidative damage and free radical generation. In the cell defense mechanism, the role of GSH can be described as a scavenger and co-factor in metabolic detoxification of ROS⁹². GSH levels, a co-substrate of GSH-Px may regulate natural antioxidant enzyme activities. Namely, changes in GSH levels characterize GSH-Px behavior.

In the activated neutrophils, MPO, an iron-containing protein, utilizes high reactive radicals (H_2O_2) to oxidize a wide variety of substrate including many pharmacological agents and xenobiotics to radical intermediates⁹³.

Cells have complex electrical systems sensitive to external E- and B-fields. An important aspect of understanding the possible effects of ELF B-fields on living systems is the analysis of ionic and molecular pathways involved in the interaction of these fields at the cellular and subcellular levels⁹⁴.

Cell membrane potential and the concentration of ions can be altered according to the change in the penetration level of ELF B-fields into the cells⁹⁴⁻⁹⁶. Studies have shown increased free radical activity in cells exposed to these fields, *in vitro* and *in vivo* conditions⁹⁶⁻¹⁰¹.

Biological effects of ELF B-fields on free radical levels (MDA, NO) and on the levels of defense mechanisms (GSH, MPO) are summarized in Table 1. In the Table, statistically significant changes in all parameters of brain, liver, heart, lung, kidney, plasma and serum are indicated by starred arrows.

Table 1 - Changes in free radical levels (MDA, NO), antioxidant enzymes (GSH, MPO) and electrolytes in brain, liver, heart, lung, kidney, plasma and serum under ELF B-field exposure

Strength (mT)		Exposure Periods									
		1mT		1.5mT		2mT		3mT			
Day		5 days		4 days		7 days		5 days		5 days	
Duration		4h	8h	Cont. (#)	Int. (##)	Cont. (#)	Int. (##)	4h	8h	4h	8h
Tissue	Parameter										
	MDA										
Brain		↓	↓	↓*	↓*			↑	↑*	↑	↓
Heart		↓	↑					↑	↓	↑	↓*
Lung		↑*	↓*					↑	↓	↓	↓*
Liver		↑*	↓	↑*	↑*			↑*	↑	↑	↓*
Kidney		↑*	→					↑*	↓	↓	↑
Plasma				↓	↑*						
	NO										
Brain				↓	↓						
Heart		↓*	↓*					↓	↓	↑	↓
Lung		↑*	↑							↑*	↑*
Liver		↑	↓*	↑	↓	↓*	↑	↓	↓*	↓*	↑*
Kidney				↑	↑*						
Plasma				↑*	↑*						
	GSH										
Brain				↑*	↓*						
Heart		↑*	↓					↑*	↑*	↑*	↑
Liver		↓*	↑	↑	↓	↑	→	↓*	↑	↑*	↑*
Kidney		↑*	↓					↑	↑*	↑	↑*
Plasma (RSH level)				↓	↓						
	MPO										
Brain				↑*	↑*						
Heart		↓*	↓*					↓*	↑	↑	↑*
Liver		→	↓*	↓*	↓*	↑*	↓*	↓*	↓	↓*	↓*
Kidney		↑*	↑					↑*	↑*	↑*	↑
Plasma				↑*	↑						
	Ca										
Brain				→	→			↑			
Liver				↓*	↑*						
Kidney				→	↑						
Plasma								↑*			
Serum				→	→						
	Mg										
Brain				↑*	↑*			↑			
Liver				↑*	↑						
Kidney				↑*	→						
Plasma								↑			
Serum				↑	↑*						

(#) Continuous exposure

(##) Intermittent exposure (2h on / 2h off / 2h on)

↑ : Increase

↓ : Decrease

→: No change

*: Statistically significant changes

Magnetic fields- effects on brain tissue

MDA, NOx, GSH levels and MPO activity in brain were investigated in subjects exposed to 1, 1.5, 2 or 3 mT 50-Hz B-fields with the period of daily exposure of 4h or 8h for 4 or 5 days. It was also investigated whether continuous (4h/day) and intermittent (daily 2h on / 2h off / 2h on) exposure for 4 or 5 days to a 50-Hz, 1.5 mT and 2 mT magnetic fields may influence brain electrolytes (Ca, Mg, Zn, Cu, Na, K).

MDA level in brain tissue decreased significantly by both continuous (4h/day) and intermittent (2h on / 2 h off / 2h on) exposure to 50-Hz B-field of 1.5 mT for 4 days¹⁰⁰. However, MDA level increased significantly by 8 h exposure to a 50-Hz, 2mT B-field¹⁰².

The continuous exposure to 50-Hz, 1.5 mT B-field induced a significant increase in GSH level, whereas levels were found to decrease significantly by the intermittent exposure¹⁰⁰.

MPO activities in brain were found to increase significantly for both continuous and intermittent exposure to 1.5 mT B-field after 4 days at 4 hours daily¹⁰⁰.

The brain concentrations of electrolytes (Ca, Mg) increased insignificantly in subjects exposed to 2 mT for 4h/day during 5 days. Significant increases in Mg level were observed for both continuous and intermittent exposure of 1.5 mT 4 h/day for 4 days. No significant change was found in Ca levels for both continuous and intermittent exposure to 1.5 mT for 4 h/day for 4 days¹⁰³.

Magnetic fields- effects on heart tissue

MDA, NOx, GSH levels and MPO activity were investigated in subjects exposed to a 50-Hz B-field at 1, 2 or 3 mT for 4h/day or 8h/day for 5 days.

MDA levels were decreased significantly by exposure to 3 mT for 8 h/day.

NOx levels decreased significantly only in the subjects exposed to 1 mT for both exposure periods of 4h/day and 8h/day with respect to control¹⁹.

Increments statistically significant in heart GSH level were observed for all the intensities of B-field studied (1, 2, and 3 mT) for 4 h/day exposure. Similarly, GSH levels increased significantly after exposure to 2 mT, 8 h/day for 5 days^{19,98}.

MPO activity decreased significantly by ELF B-field exposure at intensities of 1 mT for 4 h/day and 8 h/day and at 2 mT for 4h/day. However, increment statistically significant was observed in the subjects exposed to 3 mT for 8 h/day¹⁹.

Magnetic fields- effects on lung tissue

Pulmonary MDA, NOx, GSH levels and MPO activity were investigated in subjects exposed to 1, 2 or 3 mT 50-Hz B-fields with the period of daily exposure of 4 h and 8 h during 5 days.

Pulmonary MDA level increased significantly by the shorter (4 h/day) exposure of 1 mT whereas the level was found to decrease significantly by the longer exposure period (8h/day) of 1 mT and 3 mT for 5 days^{98,102}.

NOx levels were increased significantly in all of the examined subjects exposed to 1 mT (4h/day) and 3 mT (4h/day and 8h/day) for 5 days^{102,104}.

Magnetic fields- effects on liver tissue

MDA, NOx, GSH levels and MPO activities were investigated in subjects exposed to 1, 1.5, 2 or 3 mT 50-Hz B-fields with the daily exposure of 4 h and 8 h during 4, 5 or 7 days.

It was found that significant increases in MDA levels occurred for 1 mT (4 h/day, for 5 days), 1.5 mT (intermittently and continuously, 4 h/day, for 4 days), 2mT (4 h/day, for

5 days). However, with the longer daily exposure period (8 h/day) for 3 mT, a significant decrease in MDA levels was observed for 5 days^{19,100,105-107}.

NOx levels increased significantly in the subjects exposed to 3 mT (8 h/day, for 5 days) whereas decrements were observed for 1 mT (8 h/day, for 5 days), 1.5 mT (continuously, 4 h/day, for 7 days), 2 mT (8 h/day, for 5 days) and 3 mT (4h/day, for 5 days)^{19,100,105}.

GSH levels increased significantly for 3 mT (both 4 h/day and 8 h/day, for 5 days). However, decreased GSH levels were found with exposure of 1 mT (4 h/day, for 5 days), 2 mT (4 h/day, for 5 days)^{19,100,105}.

MPO activity decreased significantly in almost all of the examined subjects, whereas it increased significantly for 1.5 mT (continuous, 4 h/day, for 7 days)^{19,100,105}.

Although Ca concentrations in liver decreased by continuous exposure, it was found to increase significantly in intermittent exposure to 1.5 mT B-field for 4 h/day during 4 days. Increased Mg levels were observed for both continuous and intermittent exposure to 1.5 mT B-field for 4 h/day during 4 days, but this increment was statistically significant only for the continuous exposure¹⁰³.

Magnetic fields- effects on kidney tissue

Renal MDA, NOx, GSH levels and MPO activity were investigated in subjects exposed to 1, 1.5, 2 or 3 mT 50-Hz B-fields with the daily exposure of 4 h or 8 h during 4 or 5 days.

A significant increase in renal MDA levels were found in subjects exposed to 50 Hz, 1 mT (4 h/day, for 5 days) and 2 mT (4 h/day, for 5 days)^{97,102}.

A significant increase in NOx level was observed in subjects intermittently exposed to 1.5 mT field during 4 days¹⁰⁸.

For the shorter daily exposure period (4 h/day), GSH levels increased significantly in subjects exposed to a 50-Hz 1 mT B-field for 5 days. With the longer daily exposure period (8 h/day), renal GSH levels increased significantly by 2 mT and 3 mT B-fields during 5 days^{102,109}.

Renal MPO activity increased in all the subjects exposed to the field but this increment was statistically significant at 1 mT (4 h/day), 2 mT (4 h/day and 8 h/day) and for 3 mT (4 h/day) for 5 days^{110,111}.

Mg levels increased significantly by continuous exposure to a 1.5 mT B-field for 4 h/day during 4 days¹⁰³.

Ca levels increased statistically insignificantly in the subjects intermittently exposed to 1.5 mT for 4 h/day during 4 days. For continuous exposure, no change was observed in Ca levels¹⁰³.

Magnetic fields- effects on plasma and serum

Plasma MDA, NOx, GSH levels, MPO activity, calcium and magnesium levels in serum were investigated in subjects exposed to a 50-Hz, 1.5 mT B-fields for both continuous (4h/day) and intermittent (2 h on/2 h off/2 h on) exposure for 4 or 7 days.

Plasma MDA levels increased significantly after intermittent exposure to 50-Hz, 1.5 mT B-fields. NOx levels were increased significantly by both continuous and intermittent exposures. Plasma MPO activity was increased by continuous exposure during 4 days¹⁰⁰.

Moreover, Na, Ca, Mg, Zn and K concentrations of plasma were analyzed for 2 mT with the period of 4 h/day for 5 days. Plasma Na, Ca and Mg concentrations increased, whereas Zn and K concentrations decreased after the exposure. The increase in Ca con-

centration was statistically significant. In the exposure groups, no differences were found in plasma Na and Mg concentrations with respect to control groups. It was observed that Ca concentration was not affected by B-field exposure⁹⁴.

In serum, Mg levels were increased by both continuous and intermittent exposure to a 1.5 mT field for 4 h/day during 4 days, but only intermittent exposure results were statistically significant. Moreover, it was found that serum Ca levels did not change significantly in both continuous and intermittent exposure to 1.5 mT for 4 h/day during 4 days¹⁰³.

3) Magnetic fields- effects on Natural Killer Cells

Natural killer (NK) cells are a subset of lymphocytes that can destroy several types of tumor cells¹¹². Current evidence indicates that decreased or absent in NK cell numbers or activity is often associated with the development or progression of cancer, acute or chronic viral infections, autoimmune diseases, immunodeficiency syndromes and psychiatric illness. It is suggested that the NK cell can participate either directly or indirectly in multiple developmental regulatory, and communication networks of the immune system. In this sense, NK cell is a remarkably efficient effector cell which is not only equipped for killing but is also capable of rapid response to exogenous or endogenous signals by producing a variety of cytokines and factors involved in interactions between immune and non-immune cells¹¹³. ELF-MF were reported both to enhance or impair the activity or number of circulating natural killer cells¹¹⁴⁻¹¹⁶ while no effect was observed in other studies¹¹⁷.

We observed a marked decrease in splenic NK cell activity in subjects exposed to a 50-Hz, 2 mT B-field with a daily exposure period of 4 h during 5 days^{102,118,119}.

4) Genetic Programming and Neural Network Studies

With the results of biochemical studies, it was also planned to determine whether genetic programming is appropriate to analyze and formulate models of biological effects of EMF B-fields, on body tissues and neural networks.

How electric current affects wound healing was investigated by the mathematical modeling and formulation using Genetic Programming (GP) based on results of wound tissue contents of hydroxyproline^{83, 120}.

50-Hz B-fields of 1, 2 and 3 mT effects on MDA level and MPO activity in kidney tissues were formulated using GP. Standard deviation and correlation coefficient of 0.07, and 0.90 for MPO and 0.13 and 0.92 for MDA, respectively, where the accuracies of the proposed GP models are quite high, were used for modeling¹²¹.

The GP model contributes an analytical expression in the form of an interpolation formula that will enable other researchers in this field to determine changes in hydroxyproline contents of wound, MDA level, and MPO activity without further experiments and waste of animals^{84, 121}

It was also aimed to use Neural Network (NN) as a tool to formulate and model ELF EMF effects on the skin by determining collagen synthesis and hydroxyproline level after exposure to 50-Hz B-fields of 1, 2 or 3 mT for 4 h/day or 8 h/day for 5 days.

Keeping the above results in view, it can be concluded that NNs can be effectively used to formulate and model complex relationships especially where no valid models exist as for estimation of hydroxyproline levels and collagen synthesis in the skin. Furthermore the proposed NNs enable to determine the possible triggering level(s)

through studying a greater number of application periods and field intensities without additional experiments. In future, some of other computing methods with a detailed parametric study will be used.^{84,86}

Acknowledgements

EM Field measurements were performed with the devices purchased by a grant from the Gazi University Research Foundation, Project No: 01/2003-62.

Studies on electric field were supported by grants from the Gazi University Research Foundation (Projects TF.01/2004-04, TF.01 / 95-4 and SBE 11 / 94-12)

Studies on magnetic fields were supported by grants from the Gazi University Research Foundation (Projects TBAG-1240, TF.01/96-21, TF. 11/98-12 and BAP: 01/2004-96)

References

1. Tenforde TS, Kaune WT. Interaction of extremely low frequency electric and magnetic fields with humans. *Health Phys* 1987; 53(6): 585-606.
2. Kheifets LI, Afifi AA, Buffler PA, *et al.* Occupational EMF exposure and brain cancer: a meta-analysis. *J Occup Environ Med* 1995; 37: 1-15.
3. Kheifets LI, Afifi AA, Buffler PA, *et al.* Occupational electric and magnetic field exposure and leukaemia: a meta-analysis. *J Occup Environ Med* 1997; 39: 1074-91.
4. Kheifets LI. Electric and magnetic field exposure and brain cancer: A review. *Bioelectromagnetics* 2001; 22(S5): 120-31.
5. Loomis DP, Savitz DA, Ananth CV. Breast cancer mortality among female electrical workers in the United States. *J Natl Cancer Inst* 1994; 86(12): 921-5.
6. Coogan PF, Clapp RW, Newcomb PA, *et al.* Occupational exposure to 60-hertz magnetic fields and risk of breast cancer in women. *Epidemiology* 1996; 7: 459-64.
7. Tynes T, Hannevik M, Andersen A, *et al.* Incidence of breast cancer in Norwegian female radio and telegraph operators. *Cancer Causes Control* 1996; 7(2): 197-204.
8. Feychting M, Forssén U, Rutqvist LE, *et al.* Magnetic fields and breast cancer in Swedish adults residing near high-voltage power lines. *Epidemiology* 1998; 9: 392-7.
9. Kheifets LI, Matkin CC. Industrialization, electromagnetic fields, and breast cancer risk. *Environ Health Perspect* 1999; 107(S1): 145-54.
10. Forssén UM, Feychting M, Rutqvist LE, *et al.* Occupational and residential magnetic field exposure and breast cancer in females. *Epidemiology* 2000; 11(1): 24-9.
11. Erren TC. A meta-analysis of epidemiologic studies of electric and magnetic fields and breast cancer in women and men. *Bioelectromagnetics* 2001; 22(S5): 105-19.
12. Foster KR. The mechanisms paradox. In Ayrapetyan SN & Markov MS, eds. *Bioelectromagnetics Current Concepts*. Netherlands: Springer Press, 2006, 17-29.
13. Zhadin M, Giuliani L. Some problems in modern bioelectromagnetics. *Electromagn Biol Med* 2006; 25: 227-43.
14. Giuliani L, Grimaldi S, Lisi A, *et al.* Action of combined magnetic fields on aqueous solution of glutamic acid: the further development of investigations. *BioMag Res Tech* 2008; 6(1): 1-7.
15. Del Giudice E, Preparata G, Fleischmann M. QED coherence and electrolyte solutions. *J Electroanal Chem* 2000; 482: 110-6.
16. Simko' M, Droste S, Kriehuber R, *et al.* Stimulation of phagocytosis and free radical production in murine macrophages by 50 Hz electromagnetic fields. *Eur J Cell Biol* 2001; 80: 562-6.
17. Lupke M, Rollwitz J, Simko' M. Cell activating capacity of 50 Hz magnetic fields to release reactive oxygen intermediates in human umbilical cord blood-derived monocytes and in mono mac 6 cells. *Free Radic Res* 2004; 38(9): 985-93.
18. Rollwitz J, Lupke M, Simko' M. Fifty-hertz magnetic fields induce free radical formation in mouse bone marrow-derived promonocytes and macrophages. *Biochim Biophys Acta – General Subjects* 2004; 1674: 231–8.

19. Canseven AG, Coskun S, Seyhan N. Effects of various extremely low frequency magnetic fields on the free radical processes, natural antioxidant system and respiratory burst system activities in the heart and liver tissues. *Indian J Biochem Biophys* 2008; 45: 326-31.
20. Blank M. Electric stimulation of protein synthesis in muscle. *Adv Chem Ser* 1995; 250: 143-53.
21. Korenstein R, Somjen D, Fischler H, *et al.* Capacitative pulsed electric stimulation of bone cells. Induction of cyclic-AMP changes and DNA synthesis. *Biochim Biophys Acta* 1984; 803(4): 302-7.
22. Fukuzumi K. Application of electric currents to in vitro suspended condylar cartilage cells. *Seicho. J Growth* 1992; 31: 89-102.
23. Guler G, Turkozer Z, Tomruk A, *et al.* The protective effects of N-acetyl-L-cysteine and epigallocatechin-3-gallate on electric field-induced hepatic oxidative stress. *Int J Radiat Biol* 2008; 84(8): 669-80.
24. Valko M, Rhodes CJ, Moncol J, *et al.* Free radicals, metals and antioxidants in oxidative stress-induced cancer. *Chem Biol Interact* 2006; 160: 1-40.
25. Sundaram K, Panneerselvam KS. Oxidative stress and DNA single strand breaks in skeletal muscle of aged rats: role of carnitine and lipoic acid. *Biogerontology* 2006; 7: 111-8.
26. Stegemann H, Stalder K. Determination of hydroxyproline. *Clin Chim Acta* 1967; 18: 267-73.
27. Beuge JA, Aust SD. Microsomal lipid peroxidation. *Methods Enzymol* 1978; 52: 302-10.
28. Cassini A, Ferrali M, Pompelam A, *et al.* Lipid peroxidation and cellular damage in extrahepatic tissues of bromobenzene intoxicated mice. *Am J Pathol* 1986; 123: 520-31.
29. Green LC, Wagner DA, Glogowski J, *et al.* Analyses of nitrate, nitrite and [15N] nitrate in biological fluids. *Anal Biochem* 1982; 126: 131-8.
30. Miranda KM, Espey MG, Wink DA. A rapid simple spectrophotometric method for simultaneous detection of nitrate and nitrite. *Nitric Oxide* 2001; 5: 67-71.
31. Paglia DE, Valentine WN. Studies on the quantitative and qualitative characterization of erythrocyte glutathione peroxidase. *J Lab Clin Med* 1967; 70: 158-70.
32. Sun Y, Oberley LW, Li Y. A simple method for clinical assay of superoxide dismutase. *Clin Chem* 1988; 34: 497-500.
33. Lowry OH, Roseberg NJ, Farr AL, *et al.* Protein measurement with folin phenol reagent. *J Biol Chem* 1951; 193: 265-75.
34. Hillegass LM, Griswold DE, Brickson B. Assessment of myeloperoxidase activity in whole rat kidney. *J Pharmacol Methods* 1990; 24: 285-95.
35. Aebi H. Catalase. In Bergmeyer HU ed. *Methods of Enzymatic Analysis*. New York: Academic Press, 1974; 673-7.
36. Choong YS, Humphrey SM. Differences in the regional distribution and response to ischaemia of adenosine-regulating enzymes in the heart. *Basic Res Cardiol* 1987; 82: 576-84.
37. Prajda N, Weber G. Malignant transformation-linked imbalance: decreased XO activity in hepatomas. *FEBS Lett* 1975; 59: 245-9.
38. Guler G, Hardalac F, Aricioglu A. Examination of electric field effects on tissues by using back propagation neural network. *J Med Syst* 2005; 29(6): 679-708.
39. Hardalac F, Guler G. Examination of static and 50 Hz electric field effects on tissues by using hybrid genetic algorithm and neural network. *Expert Syst* 2008; 25(4): 349-66.
40. Canseven AG, Seyhan N. Design, installation and standardization of homogenous magnetic field systems for experimental animals. In: Hozman J, Kneppo P, eds. *IFMBE Proc. Vol. 11. Prague: IFMBE. 2005. ISSN 1727-1983 (Proceedings of the 3rd European Medical & Biological Engineering Conference – EMBEC'05. Prague, Czech Republic, 20–25.11.2005), 2005a; 2333-8.*
41. Woessner JF. The determination of hydroxyproline in tissue and protein samples containing small proportions of this aminoacid. *Arch Biochem Biophys* 1961; 93: 240-7.
42. Aykac G, Uysal M, Yalcin AS, *et al.* The effect of chronic ethanol ingestion on hepatic lipid peroxide, glutathione, glutathione peroxidase and glutathione transferase in rats. *Toxicology* 1985; 36: 71-6.
43. Glowick SP, Kaplan SD. Myeloperoxidase activity. *Methods in Enzymology*. New York: Academic Press, 1955, 1: 769-82.
44. Gulay Z, Imir T. Anti-candidial activity of natural killer (NK) and lymphokine activated killer (LAK) lymphocytes in vitro. *Immunobiology* 1996; 195: 220-30.
45. Prockop DJ, Kivirikko KI. Heritable diseases of collagen. *N Engl J Med* 1984; 311(6): 376-86.
46. Myllyharju J, Kivirikko KI. Collagens and collagen-related diseases. *Ann Med* 2001; 33: 7-21.

47. Kar K, Kishore N. Enhancement of thermal stability and inhibition of protein aggregation by osmolytic effect of hydroxyproline. *Biopolymers* 2007; 87: 339-51.
48. Guler G, Atalay Seyhan N. Changes in hydroxyproline levels in electric field tissue interaction. *Indian J Biochem* 1996a; 33: 531-3.
49. Guler G, Atalay Seyhan N, Ozogul C, *et al.* Biochemical and structural approach to collagen synthesis under electric fields. *Gen Physiol Biophys* 1996b; 15: 429-40.
50. Brocklehurst B, Mclauchlan KA. Free radical mechanism for the effects of environmental electromagnetic fields on biological systems. *Int J Radiat Biol* 1996; 69(1): 3-24.
51. Lai H, Singh NP. Acute exposure to 60 Hz magnetic field increases DNA strand breaks in rat brain cells. *Bioelectromagnetics* 1997; 18 (2): 156-65.
52. Juutilainen J, Kumlin T, Naarala J. Do extremely low frequency magnetic fields enhance the effects of environmental carcinogens? A meta-analysis of experimental studies. *Int J Radiat Biol* 2006; 82(1): 1-12.
53. Guler G, Seyhan N, Aricioglu A. Effects of electric fields on radical and antioxidant enzymes levels in spleen and testis of guinea pigs. *Gazi Med J* 2004; 2: 99-104.
54. Guler G, Hardalac F, Aricioglu A. Examination of electric field effects on lipid peroxidation and antioxidant enzymes by using multilayer perceptron neural network. *GUJ Sci* 2005a; 18(1): 27-37.
55. Guler G, Aricioglu A, Seyhan N. Effect of static and 50 Hz electric fields on the activity of superoxide dismutase and the level of thiobarbituric acid-reactive substances in guinea pigs. *Gen Physiol Biophys* 2006; 25(2): 177-93.
56. Seyhan N, Guler G. Review of in vivo static and ELF Electric fields studies performed at Gazi Biophysics Department. *Electromagn Biol Med* 2006; 25(4): 307-23.
57. Van Wijngaarden E, Savitz DA, Kleckner RC, *et al.* Exposure to electromagnetic fields and suicide among electric utility workers a nested case-control study. *Occup Environ Med* 2000; 57: 258-63.
58. Kaune WT, Dovan T, Kavet RI, *et al.* Study of high and low- current-configuration homes from the 1988 Denver childhood cancer study. *Bioelectromagnetics* 2002; 23: 177-88.
59. Qiu C, Fratiglioni L, Karp A, *et al.* Occupational exposure to electromagnetic fields and risk of Alzheimer's disease. *Epidemiology* 2004; 15: 687-94.
60. Guler G, Turkozer Z, Seyhan N. Electric field effects on Guinea pig serum: the role of free radicals. *Electromagn Biol Med* 2007; 26(3): 207-23.
61. Turkozer Z, Guler G, Seyhan N. Effects of exposure to 50 Hz electric field at different strengths on oxidative stress and antioxidant enzyme activities in the brain tissue of guinea pigs. *Int J Radiat Biol* 2008; 84(7): 581-90.
62. Deno DW, Zaffanella LE, Silva JM. Transmission line electric field shielding by objects. *IEEE T Power Deliver* 1987; 2(1): 269-80.
63. Hirata A, Caputa K, Dawson TW, *et al.* Dosimetry in models of child and adult for low-frequency electric field. *IEEE Trans Biomed Eng* 2001; 48(9): 1007-12.
64. Menor C, Fernandez-Moreno MD, Fueyo JA, *et al.* Azathioprine acts upon rat hepatocyte mitochondria and stress-activated protein kinases leading to necrosis: protective role of N-acetylcysteine. *J Pharmacol Exp Ther* 2004; 311: 668-76.
65. Ritter C, Reinke A, Andrades M, *et al.* Protective effect of N-acetylcysteine and deferoxamine on carbon tetrachloride-induced acute hepatic failure in rats. *Crit Care Med* 2004; 32: 2079-83.
66. Aruoma OI, Halliwell B, Hone BM. The antioxidant action N-acetylcysteine: its reaction with hydrogen peroxide, hydroxyl radical, superoxide, and hypochlorous acid. *Free Radic Biol Med* 1989; 6: 593-7.
67. Sadowska AM, Manuel-Y-Keenoy B, De Backer WA. Antioxidant and anti-inflammatory efficacy of NAC in the treatment of COPD: discordant in vitro and in vivo dose effects: a review. *Pulm Pharmacol Ther* 2007; 20: 9-22.
68. Nagle DG, Ferreira D, Zhou YD. Epigallocatechin-3-gallate (EGCG): Chemical and biomedical perspectives. *Phytochemistry* 2006; 67: 1849-55.
69. Yang CS, Lambert JD, Ju J, Lu G, *et al.* Tea and cancer prevention: molecular mechanisms and human relevance. *Toxicol Appl Pharmacol* 2007; 224: 265-73.
70. Warner DS, Sheng H, Batinic-Haberle I. Oxidants, antioxidants and the ischemic brain. *J Exp Biol* 2004; 207: 3221-31.
71. Guler G, Turkozer Z, Ozgur E, *et al.* Antioxidants alleviate electric field-induced effects on lung

- tissue based on assays of heme oxygenase-1, protein carbonyl content, malondialdehyde, nitric oxide, and hydroxyproline. *Sci Total Environ* 2009; 407: 1326-32.
72. Trevor WD, Caputa K, Stuchly MA. A comparison of 60 Hz uniform magnetic and electric induction in the human body. *Phys Med Biol* 1997; 42: 2319-29.
 73. Wertheimer N, Savitz DA, Leeper E. Childhood cancer in relation to indicators of magnetic fields from ground current sources. *Bioelectromagnetics* 1995; 16(2): 86-96.
 74. Hakansson N, Floderus B, Gustavsson P, *et al.* Cancer incidence and magnetic field exposure in industries using resistance welding in Sweden. *Occup Environ Med* 2002; 59: 481-6.
 75. Hakansson N, Gustavsson P, Sastre A, *et al.* Occupational exposure to extremely low frequency magnetic fields and mortality from cardiovascular disease. *Am J Epidemiol* 2003; 158(6): 534-42.
 76. Preston-Martin S, Navidi W, Thomas D, *et al.* Los Angeles study of residential magnetic fields and childhood brain tumors. *Am J Epidemiol* 1996; 143(2): 105-19.
 77. IARC Monographs On the Evaluation of Carcinogenic Risks to Human. Non-Ionizing Radiation. Part 1: static and extremely low frequency (ELF) electric and magnetic fields. Vol 80. Lyon, France: IARC Press; 2002.
 78. Tenford TS. Interaction of ELF magnetic fields with living matter. In: Polk C, Postow E, eds. *CRC Handbook of biological effects of electromagnetic fields*. Boston: CRC Press, 1986; 197-228.
 79. Adey WR. Biological effects of electromagnetic fields. *J Cell Biochem* 1993; 51: 410-6.
 80. Liburdy RP, Callahan DE, Harland J, *et al.* Experimental evidence for 60 Hz magnetic fields operating through the signal transduction cascade. Effects on calcium influx and cMYC mRNA induction. *FEBS Lett* 1993; 334(3): 301-8.
 81. Garcia-Sancho J, Montero M, Alvarez J, *et al.* Effects of extremely low frequency electromagnetic fields on ion transport in several mammalian cells. *Bioelectromagnetics* 1994; 15: 579-88.
 82. Bhagavan NV. *Medical Biochemistry*, Boston: Jones and Bartlett Publishers Inc, 2nd edition, 1992.
 83. Canseven AG, Atalay Seyhan N. Is it possible to trigger the collagen synthesis by electric current in skin wounds? *Indian J Biochem Biophys* 1996; 33: 223-7.
 84. Canseven AG, Tohumoglu G, Cevik A, *et al.* Modeling ELF Electromagnetic field effects on skin's hydroxyproline level Using Neural Network. *IU-JEEE* 2007b; 7(2): 443-58.
 85. Canseven AG, Seyhan N. Effects of ambient ELF magnetic fields: variations in collagen synthesis of guinea pigs' skin and scaling from animals to human. *Gazi Med J* 2005b; 16: 160-5 (Turkish).
 86. Canseven AG, Tohumoglu G, Cevik A, *et al.* Explicit formulation of magnetic fields effects on skin collagen synthesis. *IJNES* 2007a; 1(3): 119-25.
 87. Akdag MZ, Bilgin MH, Dasadag S, *et al.* Alteration of nitric oxide production in rats exposed to a prolonged, extremely low-frequency magnetic field. *Electromagn Biol Med* 2007; 26: 99-106.
 88. Jajte J, Grzegorzczak J, Zmyslony M, *et al.* Effect of 7 mT static magnetic field and iron ions on rat lymphocytes: apoptosis, necrosis and free radical processes. *Bioelectrochemistry* 2002; 57: 107-11.
 89. Gutteridge JMC. Lipid peroxidation and antioxidants as biomarkers of tissue damage. *Clin Chem* 1995; 41(12): 1819-28.
 90. Tribble DL, Aw TY, Jones DP. The pathophysiological significance of lipid peroxidation in oxidative cell injury. *Hepatology* 1987; 7(2): 377-86.
 91. Muriel P. Nitric oxide protection of rat liver from lipid peroxidation, collagen accumulation, and liver damage induced by carbon tetrachloride. *Biochem Pharmacol* 1998; 56: 773-9.
 92. Bray TM, Taylor CG. Tissue glutathione, nutrition, and oxidative stress. *Can J Physiol Pharmacol* 1993; 71(9): 746-51.
 93. Winterbourn CC. Biological reactivity and biomarkers of the neutrophil oxidant, hypochlorous acid. *Toxicology* 2002; 181-2: 223-7.
 94. Canseven AG, Seyhan N, Aydin A, Cevik C, *et al.* Effects of ambient ELF magnetic fields: variations in electrolyte levels in the brain and blood plasma. *Gazi Med J* 2005c; 16(3): 121-7.
 95. Canseven AG, Seyhan N, Aydin A, *et al.* Extremely low frequency electromagnetic field effect on brain tissue and blood plasma electrolytes. *Med Biol Eng Comput* 1999; 37(Suppl. 2): 1336-7.
 96. Kula B, Sobczak A, Kuska R. Effects of static and ELF magnetic fields on free radical processes in rat liver and kidney. *Electro Magnetobiol* 2000; 19: 99-105.
 97. Canseven AG, Coskun S, Seyhan N. ELF magnetic fields' effects on lipid peroxidation in lung and kidney. In: Hozman J, Kneppo P, eds. *IFMBE Proc. Vol. 11. Prague: IFMBE. 2005. ISSN 1727-1983 (Proceedings of the 3rd European Medical & Biological Engineering Conference – EMBEC'05. Prague, Czech Republic, 20–25.11.2005), 2005d, 4748–52.*

98. Canseven AG, Coskun S, Seyhan N. Magnetic fields have an effect on antioxidant defense system in heart tissue. In: Hozman J, Kneppo P, eds. IFMBE Proc. Vol. 11. Prague: IFMBE. 2005. ISSN 1727-1983 (Proceedings of the 3rd European Medical & Biological Engineering Conference – EMBEC'05. Prague, Czech Republic, 20–25.11.2005), 2005e, 2226-8.
99. Canseven AG, Ozel U, Bilgihan A, *et al.* Effects of environmental ELF magnetic fields on myeloperoxidase (MPO) activity. In: Hozman J, Kneppo P, eds. IFMBE Proc. Vol. 11. Prague: IFMBE, 2005. ISSN 1927-1983 (Proceedings of the 3rd European Medical & Biological Engineering Conference – EMBEC'05. Prague, Czech Republic, 20–25.11.2005), 2005f, 2232-6.
100. Coskun S, Balabanli B, Canseven A, *et al.* Effects of continuous and intermittent magnetic fields on oxidative parameters in vivo. *Neurochem Res* 2009; 34: 238-43.
101. Kula B, Sbozack A, Kuska R. Effects of electromagnetic field on free radical processes in steelworkers. Part I. Magnetic field influence on the antioxidant activity in red blood cells and plasma. *J Occup Health* 2002; 44: 226-9.
102. Seyhan N, Canseven AG. In vivo effects of ELF MFs on collagen synthesis, free radical processes, natural antioxidant system, respiratory burst system, immune system activities, and electrolytes in the skin, plasma, spleen, lung, kidney, and brain tissues. *Electromagn Biol Med* 2006; 25: 291-305.
103. Akay C, Canseven AG, Erdem O, *et al.* Effect of intermittent and continuous exposure to electromagnetic field on calcium and magnesium levels in serum, brain, liver and kidney tissues. Abstracts of 44th Congress of the European Societies of Toxicology, 7-10 October 2007, Amsterdam, Netherlands/Toxicology Letters, 172S, S112 - O03, DOI:10.1016/j.toxlet.2007.05.300.
104. Canseven AG, Coskun S, Seyhan N. Effects of continuous exposure to 50 Hz magnetic fields on nitric oxide levels in lung. Proc, 4th International Workshop on Biological Effects of EMFs, Crete, 2006a; Vol. II, 1407-11.
105. Tomruk A, Coskun S, Canseven AG, *et al.* Effect of continuous and intermittent exposure to 50 Hz 1.5 mT magnetic fields on oxidative stress. 33th National Congress of Turkish Physiological Sciences, Kyrenia Cyprus, 2007. P19, (in Turkish).
106. Canseven AG, Tomruk A, Coşkun S, *et al.* Effect of intermittent and continuous exposure to 50 Hz, 1.5 mT on lipid peroxidation in liver. Proc, 4th International Workshop on Biological Effects of EMFs, Crete, 2006b; Vol. II, 1399-402.
107. Coskun S, Seyhan N, Canseven AG. Alterations induced in the lipid peroxidation levels of heart and liver tissues with ELF magnetic fields. In: Leitgeb N, Cech R, Schröttner J, Schmied P, eds. (Proceedings of the International Conference and COST 281 Workshop on Emerging EMF Technologies, Potential Sensitive Groups and Health. April 20–21, Graz, Austria), 2006.
108. Canseven AG, Tuysuz MZ, Coskun S, *et al.* Intermittent exposure to 50 Hz, 1.5 mT and increase in nitric oxide (NO) levels in kidney. Proc, 4th International Workshop on Biological Effects of EMFs, Crete, 2006c; Vol. II, 1403-6.
109. Canseven AG, Coskun S, Seyhan N. In vivo effects of ELF magnetic fields on antioxidant defense system in kidney. Proc, 4th International Workshop on Biological Effects of EMFs, Crete, 2006d; Vol. II, 1394-8.
110. Canseven AG, Ozel U, Bilgihan A, *et al.* Myeloperoxidase (MPO) activities in brain, lung and renal tissues after exposure to magnetic fields of 50 Hz. Proc. 13th Balkan Biochemical Biophysical Days & Meeting on Metabolic Disorders, Kuşadası, 2003a; P94.
111. Canseven AG, Ozel U, Bilgihan A, *et al.* The effect of ELF magnetic field exposure on kidney myeloperoxidase (MPO) activity. Proc. 13th Balkan Biochemical Biophysical Days & Meeting on Metabolic Disorders, Kuşadası, 2003b; P96.
112. Hercend T, Schmidt RE. Characteristics and uses of natural killer cells. *Immunol Today* 1988; 9 (10): 291-3.
113. Whiteside TL, Herberman RB. Role of human natural killer cells in health and disease. *Clin Diagn Lab Immunol* 1994; 1(2): 125-33.
114. Mclean JRN, Stuchly MA, Mitchel REJ, *et al.* Cancer promotion in a mouse skin model by a 60Hz magnetic field: II. Tumor development and immune response. *Bioelectromagnetics* 1991; 12: 273-87.
115. Tremblay L, Houde M, Mercier G, *et al.* Differential modulation of natural and adaptive immunity in Fisher rats exposed for 6 weeks to 60Hz linear sinusoidal continuous-wave magnetic fields. *Bioelectromagnetics* 1996; 17: 373-83.

116. House RV, McCormick DL. Modulation of natural killer cell function after exposure to 60Hz magnetic fields: confirmation of the effect in mature B6C3F1 mice. *Radiat Res* 2000; 153: 722-4.
117. Thun-Battersby S, Westermann J, Löscher W. Lymphocyte subset analyses in blood, spleen and lymph nodes of female Sprague-Dawley rats after short or prolonged exposure to a 50 Hz 100 μ T magnetic field. *Radiat Res* 1999; 152: 436-43.
118. Seyhan N, Canseven AG, Guler G. Animal Studies on the effects of ELF and static EMF. *Bioelectromagnetics Current Concepts, NATO Security through Science Series B: Physics and Biophysics*. In Ayrapetyan SN, Markov MS, eds. *The Mechanisms of the Biological Effect of Extremely High Power Pulses*, Vol. 5. Netherlands: Springer Press, 2006, 195-212.
119. Canseven AG, Seyhan N, Mirshahidi S, *et al*. Suppression of natural killer cell activity on candida stellatoidea by a 50 Hz magnetic field. *Electromagn Biol Med* 2006; 25: 79-85.
120. Canseven AG, Tohumoglu G, Cevik A, *et al*. Formulation of low intensity direct current effects on wound healing of skin using genetic programming. *Proc. of the 2007 15th Int. Conf. On Digital Signal Processing (DSP 2007c)*, 1-4 July 2007, 2007c; 507-10. DOI: 10.1109/ICDSP.2007.4288630.
121. Tohumoglu G, Canseven AG, Cevik A, *et al*. Formulation of ELF magnetic fields' effects on malondialdehyde level and myeloperoxidase activity in kidney Using Genetic Programming. *Comput Methods Programs Biomed* 2007; 86(1), 1-9 DOI: 10.1016/j.cmpb.2006.12.006.

Polarizability of normal and cancerous tissues, a radiofrequency nonlinear resonance interaction non invasive diagnostic Bioscanner Trimprob detector

Clarbruno Vedruccio

COMSUBIN, Ufficio Studi, Italian Navy, La Spezia, Italy.

Abstract

The spectrum analysis of low level E.M.F. Non-Linear Resonance Interactions (NLRI) between biological tissues and the signals emitted on three sharp frequency windows by a 'bioscanner' Trimprob, as available in literature, could be used to investigate suspected cases of disease and cancer. The paper is focused to review the scientific literature that spreads the possibility of the cancer detection by means of low level radio frequency oscillations and to explain the experimental approach necessary to deeply understand the Trimprob technology. The system is based on a non-linear radiofrequency oscillator working on 462 MHz plus the harmonics. The diseased biologic tissues, suspected of cancer, are irradiated in the oscillator "near-field" while a spectrum analyzer placed outside of the near field detects the oscillator interaction frequency lines with the tissues. The technology is provided with a very high dynamic range, that is evidenced by means of a deep depression, at the resonance, of the interested frequency line in order of 20 or more decibel (dB). When a resonance approaches, the resultant effect is quite similar to the Grid-dip meter technology, well known by radio communications and radar engineers, and that is still used to investigate the resonance of passive L/C radiofrequency oscillators as well as the new RFID (Radio Frequency Identification) widely used in the industry. The NLRI provides a selective structural characterisation, like a sort of 'electronic biopsy' response of biologic tissues in support of modern diagnostic imaging techniques. Further to existing literature describing methods for cancer detection by means of electromagnetic fields, the paper shows this innovative "in vivo" medical diagnostic equipment applications.

Key words: Bioscanner, Trimprob, N.L.R.I. (Non Linear Resonance Interaction), cancer diagnosis, electromagnetism, electronic biopsy

Review of scientific literature

In the past century, a great number of researchers have given their contribution to the study of the interactions between biological matter and electromagnetic fields. Many investigated the dielectric properties of living matter. Some others analyzed the differences between a cancerous agglomerate of cells and homogenous or 'normal' tissues. The period between the First and the Second World War spanned the early days of radio and electronics: vacuum tubes were the radio frequency oscillation generators, the spectrum ranged between a few kHz and 15 MHz. Measurements on biological materials were based on resistivity or impedance and instruments such as the Wheatstone bridge. After the second world conflict, investigations on biological materials were extended into the microwave bands¹.

Among the pioneers in this field, there were H. Fricke² and S. Morse³. In 1926, in their paper entitled "*The electric capacity of tumors of the breast*", they reported that "*malignant tumors have a greater polarizability than normal breast tissues or benign tumors*". They carried out their experiments at low frequencies around 20 kHz. Tissues were cut into small blocks and placed in a conductivity cell for measurement. They claimed that measurements performed on tissues from locations other than the breast convinced them that the method was of general applicability and that in some cases the "*measurements may be made directly on the patient*". Following the publication of these results, Fricke published a paper in which he declared that "*It seems probable that the measurement of the capacity may provide a very practical method for diagnosing the malignancy of a tumor.*" These experiences are of a great importance to explain and clarify some aspects that arises in the common use of the Bioscanner/Trimprob device, and it is extremely interesting to read this paper in which the authors wrote: "*While the resistance of biologic tissues has been studied by many investigators, little attention has been directed to their capacity*". The term "capacity" is to be associated to the well known property of the tissues which is usually called its "polarization". Theoretically we assume two type of electric capacity, the first is the "static capacity" that is independent to the frequency of the alternating current, the second is the "polarization" type that depends upon the interphases in the tissues and suggest that capacity might have a considerable biologic significance. The "polarization" capacity is related to the alternating current applied or irradiated to the tissue under test. In their paper, Fricke and Morse claim: It has been a constant surprise to find that *the capacity of malignant tumors of the breast is so consistently larger than that of normal tissues in the same location or of benign tumors as to make its estimation in any individual case clearly of diagnostic value.*

As above reported, these aspects are important to clarify the mechanism of the *non linear resonance interaction* applied to the diagnosis by means of this technology. It is known by the users, that the Trimprob works on three frequencies, and that the first is 462 MHz, while the others are the harmonics of the first ones.

Despite the frequency used for the analysis, but in accordance with the Fricke and Morse paper, the tissue capacity values have to be higher for the malignant tumors, lower for benign and much lower for healthy ones. The measured values are also greatly different in the order of four times greater for malignancy than for healthy tissues. In other words, we have to expect that a malignant cells agglomerate, that it is characterized by a high capacity, must have a non linear resonance interaction on the lower frequency of the harmonically related group emitted by the Bioscanner/Trimprob.

Differently, the benign pathologies, like benign prostate hypertrophy or breast fibromas, will not have the same capacity than a malignant tumor and of course, the non linear resonance interaction could be detected on a higher frequency.

Materials and Methods

The main feature of Trimprob apparatus is a cylindrical probe shown in fig. 1, within which a resonant cavity incorporates a transmission line tuned to the frequency of oscillation which is in the 65 cm wavelength band (462 MHz).

At the open end of this line there is a semiconductor with non-linear characteristics, which is activated by a nanosecond electromagnetic pulse. This transient provides an injection of electromagnetic energy into the tuned line, which performs a damped oscillation. This particular tunable amplifier-oscillator represents the core of the Trimprob diagnostic device. It possesses lock-in or synchronization characteristics and, because of its particular construction, it produces a harmonically related group of coherent electromagnetic waves. These oscillations are radiated as a beam through the “beam window” of the oscillator dome at the end of the probe, where it has been geometrically focused, and the beam is used to irradiate the diseased tissues.

The working principle can be explained by considering the equivalent circuit diagram of figure 2. The left part stands for the probe and the right part for the tested biological tissue, while the coupling is represented by (virtual) interrupted lines. Inside the probe, the transistor T activates an electric circuit, which has a natural frequency of oscillation f_1 that is determined by self and capacity of this circuit. The current I passing through T is a *non-linear* function of the potential difference V . Actually, $I = -aV + bV^2 + gV^3$, where a defines a “negative resistance”. It results from a positive feedback, mediated by magnetic coupling with the self of the first circuit. This non-linear system produces stationary oscillations of well-defined amplitude, but when the probe is brought close to the tested biological tissue, it becomes an “active oscillator” that interacts with a “passive oscillator”.



Fig. 1. The Trimprob equipment is composed by the Bioscanner probe and a computer based spectrum analyzer

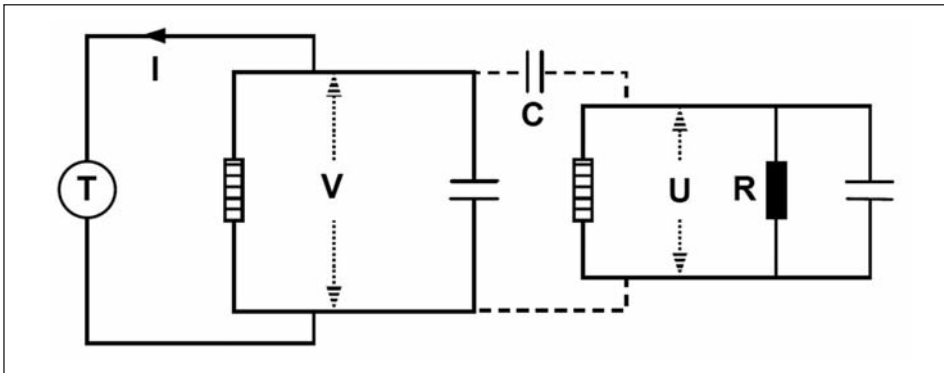

Fig. 2. Coupled active and passive oscillators equivalent electric circuit

Although the irradiated biological system contains various subsystems that could be set in forced oscillations, their mutual interactions are negligible. It is therefore sufficient to consider the effects of the active oscillator on one particular passive oscillator of given resonance frequency f_2 . We can even imagine a circuit, where the self and capacity determine the frequency f_2 , while the resistance R defines energy absorption. The probe acts there like an “open capacity” and the tested biological tissue is subjected to the resulting electric field. This type of coupling is unusual. It involves a capacity C that increases when the probe approaches the tested tissue. Since this capacity facilitates the passage of high frequency currents, we can call this a *dynamic coupling*. All these features are taken into account by *two coupled differential equations*, describing the possible variations of the potential differences V and U . The detailed mathematical treatment is available on internet¹, but the basic ideas can be expressed in simple terms. Let us consider the particular case where the active oscillator is unperturbed ($C = 0$). The equation for V reduces then to the well-known *Van der Pol* equation, initially introduced to account for the possible actions of a triode. Even when the amplification coefficient a is very small, the rest-state ($V = 0$) will be unstable. The slightest perturbation will be amplified and the capacity will accumulate charges, but when they increase, there will be also a greater tendency towards discharging. The system will end up with a stationary harmonic oscillation of frequency f_1 and given amplitude for the potential difference V . For larger values of a , higher *harmonics* will appear, since the equation for V contains terms that vary like V^2 and V^3 . This remains true when the active oscillator is coupled to a passive oscillator.

We can thus adopt a solution for V that accounts for the existence of oscillations at a fundamental frequency f and its harmonics, $2f$ and $3f$. The value of f , as well as the amplitudes and phase factors of all these components can only be specified, when we take into account the fact that V produces forced oscillations for U and that this has an effect on V , because of C . The result can be summarized in the following way: the active oscillator is able to “feel” what happens inside the tested biological tissue, since *it has to transfer energy* to the passive oscillator to produce forced oscillations of the hidden entities. The active oscillator is also able to “tell” us how the passive oscillator is responding, since the amplitude of its own oscillations is strongly reduced when there is a large energy transfer. This is revealed, indeed, by a reduction of the amplitude of the emitted wave, displayed on the screen of the spectrum analyzer. The mathematical treat-

ment reveals that the active oscillator draws more energy from the batteries when resonance is achieved, but its own energy is reduced, as if it had to make a “big effort”. This mechanism is the essence of the *non-linear resonance interaction*^{1,4,5}.

Although the values of f_1 and f_2 are fixed, it is possible to achieve, or at least to approach, *ideal resonance* where the “dip” of a given spectral line is strongest, by changing the value of C through a modification of the distance between the probe and the tested tissue. The first spectral line is very sensitive to the existence of a resonance, when the negative resistance a is small, but a higher value will allow for a simultaneous search of resonance phenomena at the fundamental frequency f and its harmonics $2f$, $3f$, etc.

The effect of this interaction is easily detectable by means of a spectrum analyzer feed by a small antenna. At the resonance, on one or more of the spectral lines, two effects are detectable: the first is related to the transfer of an amount of radiofrequency from the generator probe to the diseased tissue, that absorbs a part of the signal on the proper frequency line (dynamic resonance), while the second effect it is related to the deformation of the electromagnetic pattern emitted by the probe, due to the interaction with a resonating diseased tissue, that produces in the “near field” a sort of parasitic resonating element able to deflect the waves in other spatial directions, in the same way that beam antennas for radio communications works.

The subject under test must be further from the probe than the “near field”, and the same applies to the spectrum analyzer, which is a part of the system. Using this arrangement, it is possible to observe an effect that appears as absorption of one or more of the spectral lines radiated by the scanner. This is observed on the spectrum analyzer display, that transforms the received signal into a Fast Fourier Transform (FFT). These lines are specifically tuned to the types of tissues to be investigated. At the moment, three spectral lines are used: the first, corresponding to the wavelength, responds specifically to highly anisotropic states like micro-agglomerates of cancer cells; the second line responds to parenchyma (soft tissues) diseases; the third line responds to anomalies of the lymph and vascular system.

The interaction between a non-linear active oscillator and an ordinary (linear) passive oscillator leads to the peculiar phenomenon of “non-linear resonance interaction”. A similar behavior is known as a *grid-dip meter* (g.d.m.). Initially, it contained a triode⁶ that was associated with an oscillating circuit in such a way that it delivered a stationary oscillation at *one* particular, easily tunable frequency. The tunable active oscillator could be coupled by *magnetic induction* with another oscillating circuit, containing a real coil. When such a grid-dip meter is tuned, so that its natural frequency is identical to the natural frequency of the passive oscillator, there will be a resonance. Since the active oscillator is transferring energy to the passive oscillator, the oscillating current passing through the coil of the active oscillator is reduced, and an ammeter, included in the grid circuit, will indicate this effect. At resonance, there appears a “grid-dip”, but to avoid ambiguities, the active generator should produce no harmonics. When a spectrum analyzer is used to monitor the near field and primarily the far field emitted by the g.d.m. coil in the free space, while interacting with a tuned for resonance, passive L/C simple circuit, we can observe some interesting not commonly investigated effects.

Fig. 3A and 3B shown the necessary setup for this experiment: A Millen mod. 90651-A g.d.m. placed on a laboratory wooden table near a passive oscillator composed by an U shaped coil paralleled by a 30 pf variable air spaced capacitor. The circuit is tunable in frequency around the 140-170 MHz band, that was used to facilitate the passive circuit



Fig. 3. A) Experimental asset. The far-field spectrum analyzer is placed on the table about 50 cm. far from the g.d.m and the passive oscillator. A small antenna picks up the r.f. field. The author right hand is moving the L/C oscillator tuning to achieve a resonance with the grid dip meter: when the resonance is achieved, the spectral line on the display is immediately depressed (B)

realization as well as a proper coupling with the g.d.m. The passive oscillator U coil is placed in the near field of the g.d.m. test coil. At a distance of at least 50 cm, just outside the near field, another portable spectrum analyzer with a 1/8 wavelength rod antenna picks up the g.d.m. far field.

A slight tune of the g.d.m., to achieve the resonance with the passive circuit, is evidenced by a sharp dip of the ammeter current. This common and known effect represents the normal use of the instrument. At the same time, the far field received by the spectrum analyzer antenna shows a strong dip of the corresponding frequency line as evidenced in figs. 4-5;

The spectral line will drop the amplitude more than 20 decibel and could be in the order of 30 or more dB. In other words the frequency line will disappear from the display. Instead the near field detection will show a little attenuation of the spectral line in the order of few dB. This far field monitoring, to display the waves propagation of a passive oscillator interacting with an active one, was not previously reported in literature and represents the basis of the Trimprob operations.

The use of a g.d.m. not consent the cancer or other disease detection but it is used, scaled in frequency, for field modeling purposes and for other experiments and laboratory measurements, cause the magnetic coupling of the oscillators, although the propagation of the involved radiofrequency field is the same of the diagnostic device, that is not easily influenced by magnetic-coupled passive oscillators.

The EM cancer detector is different, since it allows for an *electric* and no magnetic coupling, by means of a quarter wavelength antenna, activating charged particles inside biological tissues or other polarizable materials. Moreover, there are *harmonics*, that the spectrum analyzer allows for a distinction of possible resonance effects for anyone of the frequency components and could be considered like a sort of '*electric field capacity coupled grid dip meter*' provided of a far field detection. Both g.d.m. and Trimprob, are provided of synchronization capabilities¹ that are evidenced by a loop locking of the

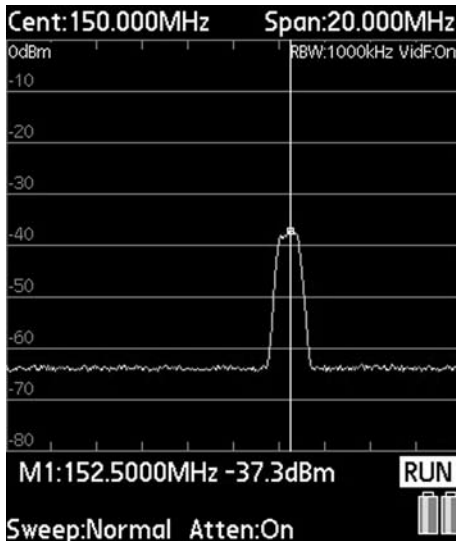

Fig. 4. The g.d.m. oscillator line out of resonance at 152.5 MHz



Fig. 5. Frequency resonance interaction, the far field spectral line is depressed

active oscillator frequency respect the passive ones. Effect evidenced by the spectrum analyzer tracking capabilities that measures not only the amplitude, but also the precise frequency at the interaction resonance. It is astonishing observe the damping force opposite to frequency variations when the two oscillators are in their respective ‘capture range’. To have diagnostic capabilities the irradiated radiofrequency by the probe has to be of few about ten milliwatt; or the interaction with the tissues will be no more evidenced cause excessive oscillator coupling and other saturation effects. A similar behavior is common with not well designed g.d.m., when these instruments are used to analyze the resonance of passive L/C oscillators, especially when the g.d.m. power is excessive. Instead, in the case of the Bioscanner, very low in level signals, in the order of microwatts could still interact with near the skin anomalies on 462 MHz, but a more sensitive spectrum analyzer is required, to display the far field. An experimental tunnel diode⁷ nonlinear oscillator probe was realized and laboratory tested by the author. This could represent a promising technology for a skin cancer like melanomas, detector, useful also for a low level e.m.f. interaction device with cells, in laboratory experiments. The lock-in characteristic is also evidenced by the immediate synchronization in frequency of a couple of ‘Bioscanner’ probes when such a non-linear oscillators are in their respective ‘capture range’, that is about one wavelength wide. Greatest distances are possible with the aids of corner reflectors to focusing both the probe fields. The spectral far field line amplitude, due to the phase synchronization of the oscillators, is greater than for a single oscillator.

Opinions and implications

The first experiments, carried out by the author in the early days of the Bioscanner invention and development, as well as several clinical trials during the last years, have

scientifically validated the efficacy of the described low level e.m.f. cancer detector in several body organs like breast⁸, prostate⁹⁻¹¹, bladder^{12, 13}, stomach-duodenum^{14, 15}, thyroid^{16, 17}, colon-rectum¹⁸. The Trimprob clinical diagnostic accuracy as reported in Table 1, that resumes the above mentioned clinical studies¹⁹, spans several applications in the field of characterization of benign vs. malignant pathologies, prevention, screening capabilities and some other not disclosed here, possible applications.

In the last years was only possible to realize a not invasive diagnostic tool based on this technology, commercially named Trimprob, that was based on these researches, 'medical CE' certified, and quite diffused in Italy and abroad. The above mentioned results, still requires an important consideration: the cancer detection is possible, with the described device, only on the cited sharp frequency window centered on 462 MHz, no more than 8 MHz wide. Outside this range, the nonlinear resonance generator doesn't interact with the diseased tissues.

Table 1 - Trial Results Synthesis

Organ	Sens.	Specific.	V.P.P.	V.P.N.	Accuracy
Prostate					
1 - Trials by dr. Bellorofonte (Milano); <i>European Urology</i> (2005)	95	43	94	90	
2 - Trials by prof. Tubaro (Roma); <i>Urology</i> (2008)					
Solo Trimp.	86	63	60	88	72
Trimp+DRE	96	57	59	95	72
Bladder					
Trials by dr. Leucci (Lecce); <i>Electromagnetic Biology and Medicine</i> (2007)	87,5	90,5	83,3	91,1	89,5
Breast					
Trials by IEO-MI (dr. Paganelli-dr. De Cicco); <i>Tumori</i> (2006)	84	75		80	72
Tyroid					
Trials by Prof. Sacco; <i>Chirurgia Italiana</i> (2007)	100	100			100
Stomach-duodenum					
1 - Trials by dr. Mascia; <i>International Review of the Armed Forces Medical Service (IRAFMS)</i> (2005)	93	93	95	92	
2 - Trials by dr. Sacco; <i>Chirurgia Italiana</i> (2007)	100	100			
Rectum					
Trials by prof. Leo, Dr. Vannelli Istituto Nazionale dei Tumori (MI); <i>Disease of Colon & Rectum</i> (2009)	94	85	86	93	89

References

1. Meessen A. Working Principle of an EM Cancer Detector. Available on internet, <http://www.meessnen.net/AMeessnen/EMcancerDet2.pdf>; Institut de Physique, Université Catholique de Louvain, Louvain-la-Neuvre, Belgium 2000.
2. Fricke H. Phys Rev 21, 708 (1923); J Gen Physiol 9, 137-52 (1925); Phys Rev 1925; 26, 682-7.
3. Fricke H, Morse A. Phys Rev 25, 361-367 (1925); J Gen Physiol 9, 153-167 (1925); The electric capacity of tumors of the breast. J Cancer Res 1926; 10: 340-76.
4. Vedruccio C, Meessen A. EM cancer detection by means of non-linear resonance interaction. Proc. and Extended Papers book. PIERS 2004, Progress in Electromagnetics Research Symposium, Pisa, Italy, March 28-31, 2004; 909-12.
5. Vedruccio C, Meessen A. Nuove possibilità diagnostiche tramite onde elettromagnetiche. Fisica in Medicina, AIFM, 2004; 3: 225-30.
6. Hund, A. High frequency measurements. McGraw-Hill, 1951.
7. Manager, H.R.L. et al. Tunnel diode manual. General Electric, 1961.
8. De Cicco C, Mariani L, Vedruccio C, et al. Clinical Application of Spectral Electromagnetic Interaction in Diagnosis of Breast Lesions. Results of a Pilot Study. Tumori 2006; 92(3): 207-12.
9. Bellorofonte C, Vedruccio C, et al. Non-invasive detection of prostate cancer by electromagnetic interaction. Eur Urol 2005; 47: 29-37.
10. Da Pozzo L. et al. Tissue Resonance Interaction Method for non Invasive Diagnosis of Prostate Cancer: a Multicenter Clinical Evaluation. BJU Int 2007; 100(5): 1055-9.
11. Tubaro A, De Nunzio C, Trucchi A, et al. The Electromagnetic Detection of Prostatic Cancer: Evaluation of Diagnostic Accuracy. Urology 2008; 72(2): 340-4.
12. Leucci G, Vedruccio C, et al. Studio Pilota per la Diagnosi del Carcinoma Vescicale mediante l'utilizzo del TRIMprob, (preliminary results), proc. of XI Congresso Nazionale AURO, Department of Urology, Ospedale Vito Fazzi, Lecce, Italy, 6-9 Oct 2004.
13. Gervino G, et al. Diagnosis of Bladder Cancer at 465 MHz. Electromagn Biol Med 2007; 26(2): 119-34.
14. Vedruccio C, Mascia E, Martines V. Ultra High Frequency and Microwave Non-linear Interaction Device for Cancer Detection and Tissue Characterization, a Military Research approach to prevent Health Diseases. International Review of the Armed Forces Medical Services (IRAFMS) 2005; 78(2): 121-6.
15. Sacco R, Sammarco G, De Vinci R, et al. Relief of gastric cancer with an electromagnetic interaction system (TRIMprob) in outpatients. Chir Ital 2007; 59(6): 823-8.
16. Lucisano AM, Innaro N, Pata F, et al. Diagnosis of Carcinoma in Multinodular Goiter by Electromagnetic Interactions. Preliminary Results. European Surgical Research 2006; 38: 129-32.
17. Sacco R, Innaro N, Pata F, et al. Diagnosi Preoperatoria di Carcinoma Incidentale in Gozzo Multinodulare mediante Interazioni Elettromagnetiche. Chir Ital 2007; 59(2): 247-51.
18. Vannelli A, Leo E, Battaglia L, et al. New technique for diagnosis of rectal cancer. Dis Colon Rectum 2009; 52(1): 162-6
19. Vedruccio C, Ricci C. The Trimprob Non Linear Resonance Interaction for early cancer detection. In: Casciaro S, Samset E, Eds. Minimally Invasive Therapies and Novel Embedded Technologies. Lecce: Lupiensis Biomedical Publications, 2007.

