



European Softball Federation
Fédération Européenne Softball

COMPETITIONS REGULATIONS

Official Edition 2011

As approved by the Executive Council of the ESF of November 1st 1998. With amendments adopted by: the Executive Council of Nov. 29th 2008, the Congress Commission of February 6th 2009, the General Congress of Febr. 6th 2010, the General Congress of Febr. 5th 2011, the Executive Council of Febr. 6th and Apr. 30th 2011.

EUROPEAN COMPETITIONS	1
ELIGIBILITY	2
PARTICIPATION	3
ENTRIES FOR COMPETITIONS	3
FORMAT OF COMPETITIONS	4
PROMOTION AND RELEGATION	9
RATINGS	10
COMPETITION SYSTEM	13
RESOLUTION OF TIES	15
PROGRAM OF COMPETITIONS	15
PLAYING RULES	16
PLAYERS	16
PLAYERS LICENCES	18
PLAYERS QUALIFICATION	19
OFFICIAL COMPETITION ROSTER	19
CEREMONIAL	19
PLAYING FIELDS	20
TEAM UNIFORM	20
CANDIDATES FOR ORGANIZING A COMPETITION	20
INSPECTION OF COMPETITION ORGANIZATION	21
ASSIGNMENTS AND APPOINTMENTS OF OFFICIALS	21
DUTIES OF OFFICIALS	22
ACCREDITATION OF MEDIA	23
SCOREKEEPING AND STATISTICS	24
PROTESTS	24
OBLIGATIONS AND DUTIES OF ORGANIZERS	24
OBLIGATIONS AND DUTIES OF PARTICIPATING TEAMS	25
SPECIFIC REGULATIONS FOR YOUTH COMPETITIONS	26
SPECIFIC REGULATIONS FOR SLOWPITCH COED COMPETITIONS	27
MASSIMO ROMEO YOUTH TROPHY	29

EUROPEAN COMPETITIONS

01.00. The ESF organizes, in accordance with its Statutes and Regulations, Softball Competitions in Europe, to be referred to as the "ESF Competitions". ESF Competitions include the following:

- "European Championships": Softball competitions involving national teams from Affiliated Federations;
- "European Cups": Softball competitions involving club teams from Affiliated Federations;
- the "Massimo Romeo Youth Trophy" involving national teams and/or club teams, whether or not from Affiliated Federations, and which will be run in accordance with CR 42.

01.01. The "European Championships" for National Teams, to be played according to the following schedule:

Year	Women		Girls		Men	Junior Boys	Coed SP
	Senior	Under 22	Junior	Cadette			
2011	X			X		X	X
2012		X	X		X		
2013	X			X		X	X
2014		X	X		X		
2015	X			X		X	X
2016		X	X		X		

01.02. The Organizers of the European Championships shall be appointed at the annual General Congress in the year before the Championships concerned.

01.03. The "European Cups" for Club Teams:

01.03.01. The "European Champions Cup" for National League Champions

01.03.02. The "European Winners Cup" for National Federation Cup Winners

01.04.01. *European Championships shall be played each year during the month of July, absent extenuating circumstances as decided by the Executive Council.*

01.04.02. The European Cups for Women shall be played each year in the third complete week of August. The European Cups for Men shall be played each year in the fourth complete week of August. *The European Cup Coed Slowpitch shall be played in the first week of August.* If special reasons require so, the Executive Council may change these dates.

01.05. The Organizers of the European Cups shall be appointed at the annual General Congress in the year of the Cups concerned.

02. European Competitions shall normally start on the Monday and end on the Saturday of a given week. Organizers wishing to deviate from this Regulation shall present together with their candidature a request for derogation, to be submitted to the approval of the annual General Congress appointing the Organizers. Any request for changes to the respective dates of the starts of the competition after the Congress shall be decided by the Executive Council.

ELIGIBILITY

03.01. All Federations affiliated to the ESF and that have discharged their obligations to the ESF as per article 2.2.2 of the Statutes are eligible to take part in the European Championships.

03.02. The National League Champions of the preceding year of Federations affiliated to the ESF and that have discharged their obligations to the ESF as per article 2.2.2 of the Statutes, are eligible to take part in the European Champions Cup.

03.03. The National Federation Cup Winners of the preceding year of Federations affiliated to the ESF and that have discharged their obligations to the ESF as per article 2.2.2 of the Statutes, are eligible to take part in the European Winners Cup. In the case when a Federation does not have a National Federation Cup the runner up of their national League Championship may take part in the European Winners Cup.

03.04. Should a team entitle to participate in the Champions Cup or Winners Cup, renounce its right, the runner-up of the National League Championship or National Federation Cup may be admitted to the Competition concerned. If the runner-up also decides to renounce its right, the team ranked third shall be eligible. If the third ranked team also renounces, no other team can substitute.

04.01. The team that wins the Champions Cup or Winners Cup in any one year, shall have the right to participate as defending Champion in the corresponding European Competition the following year.

04.02. If this team is also the National League Champion and/or National Federation Cup holder in that year, then the runner-up of the National Competition concerned shall also be eligible for the corresponding European Competition.

04.03. Shall a defending Champion renounce to its right of participation, this right shall not be transferred to another team.

04.04. When a defending Champion uses its right to defend its title, its participation shall not influence the promotion and/or relegation of other participating teams in the said Competition.

05.01 For purposes of CR in the practical application of articles 3 and 4 above in respect of eligibility, the European Champions Cup takes precedence over the European Winners Cup with the following dispositions.

05.01.01 When a team that enters a European Cup Competition is eligible for both the European Champions Cup and the European Winners Cup, that team will only be eligible for the European Champions Cup.

05.01.02. When only one team represents its country in a Cup Competition, in B Pool, this team is eligible to participate in either the European Champions Cup or the European Winners Cup.

05.01.03 When only one team is representing its country in a Cup Competition, in B Pool, this team has the right to change its entry from one Cup to the other, subject to the following conditions: (a) the team has submitted a valid Entry Form in compliance with CR 08.02; (b) the request must be received by the ESF at latest 15 days before the March 1st date to pay the Entry Fees (dates contemplated in CR 08.03.01 and CR 08.03.02). The change is subject to the approval of the Executive Council.

PARTICIPATION

06. The maximum number of participating teams per Federation in the same Competition will be two (2).

07. Deleted

ENTRIES FOR COMPETITIONS

08.01. In order to enter for a Competition, an eligible team shall provide the relevant Entry Form and pay the corresponding Entry Fee.

08.02. The duly completed and signed Entry Form must be received by the ESF Secretary General before December 20th of the year before the one in which the Competition is to be held.

08.03. The Entry Fee as determined by the Executive Council of the ESF must be received by the ESF Treasurer:

08.03.01. before March 1st of the year in which the Competition is to be held, when the official announcement of the appointment of the Organizers of the Competition has been made at the latest at the annual General Congress of this given year. A team may cancel its entry without penalty by notifying in writing to the ESF Secretary General before March 1st for that specific Competition.

08.03.02. Within 30 days of the official announcement of the appointment of the Organizers of the Competition when such announcement has not been made at the annual General Congress entitled to do so. A team may cancel its entry without penalty by notifying in writing to the ESF Secretary General within 30 days of the official announcement for that specific Competition.

08.04. After the limit date as contemplated:

08.04.01. in article 08.02, late submission of an Entry Form is subject to the assessment of a late-filing penalty, which amount is determined by the Executive Council of the ESF. However, in no case will such late entries be accepted after the final day of the Congress.

08.04.02. in article 08.03, late payment of an Entry Fee is subject to the assessment of a penalty, which amount is determined by the Executive Council of the ESF, notwithstanding further penalties and actions as decided by the Executive Council.

08.05. If after the limit dates as contemplated in article 08.03, a team withdraws from, or does not participate in a European Competition:

08.05.01. the Entry Fee remains due and is not refundable;

08.05.02. such a team may be subject to further penalties and action as decided by the Executive Council.

08.06. If, by its withdrawal or non participation, a team is directly or indirectly responsible for the cancellation of a Competition for insufficient number of teams pursuant to article CR 09.00, the ESF can not be held responsible for the possible loss or prejudice suffered by the Organizers or the other entered teams for said Competition.

08.07. In case of exceptional circumstances the Executive Council may modify the date mentioned in articles 08.02 and 08.03.

FORMAT OF COMPETITIONS

09.00. Teams subscribing to European Competitions are constituted into Divisions in each Competition. The minimum number of teams in one Competition Division will be four, not including the possible Defending Champion. The maximum number of teams in one Competition Division will be twelve, including the possible defending Champion. The Defending Champion is the Holder of the Title of Division "A" in Cup Competitions.

09.01.01. For European Championships the following format shall apply

09.01.01.01. *If four teams subscribe:*

- Double round robin "a".
- Teams ranked 1 to 4 play the "Page System" finals.

09.01.01.02. *If five teams subscribe:*

- Double round robin "a".
- Teams ranked 1 to 4 play the "Page System" finals.
- Team ranked 5 will be 5th in the Competition.

09.01.01.03. *If six teams subscribe:*

- Single round robin "a".
- Teams ranked 1 to 4 play the "Page System" finals.
- Teams ranked 5 and 6 play each other to determine places 5 and 6.

09.01.01.04. *If seven teams subscribe:*

- Single round robin "a".
- Teams ranked 1 to 4 play the "Page System" finals.
- Teams ranked 5 to 7 play a single round robin "b" to determine places 5, 6, and 7.

09.01.01.05. *If eight teams subscribe:*

- Two groups "a" and "b" both of 4 teams.
- Each group plays a single round robin.
- Teams ranked 1 and 2 in groups "a" and "b" play a single round robin "c" in which the games among these four teams will also be considered as a played game for this round robin "c".
- Teams ranked 3 and 4 of groups "a" and "b" play a single round robin "d" in which the games among these teams will also be considered as a played game for this round robin "d".
- Teams ranked 1 to 4 in group "c" play the "Page System" finals.
- Teams ranked 1 and 2 of group "d" play against each other to determine places 5 and 6.
- Teams ranked 3 and 4 of group "d" play against each other to determine places 7 and 8.

09.01.01.06. *If nine teams subscribe:*

- Two groups: one of 5 teams "a" and one of 4 teams "b".
- Each group plays a single round robin.
- Teams ranked 1 and 2 in groups "a" and "b" play a single round robin "c" in which the games among these four teams will also be considered as a played game for this round robin "c".
- Teams ranked 3, 4 and 5 of both groups play a single round robin "d" in which the games between these teams will also be considered as a played game for this round robin "d".
- Teams ranked 1 to 4 in group "c" play the "Page System" finals.
- The final results of round robin "d" will determine places 5 to 9 in the Competition.

09.01.01.07. *If ten teams subscribe:*

- Two groups "a" and "b" both of 5 teams.
- Each group plays a single round robin.
- Teams ranked 1 and 2 of in groups "a" and "b" play a single round robin "c" in which the games among these four teams will also be considered as a played game for this round robin "c".
- Teams ranked 3, 4 and 5 of both groups play a single round robin "d" in which the games between these teams will also be considered as a played game for this round robin "d".
- Teams ranked 1 to 4 in group "c" play the "Page System" finals.
- The final results of round robin "d" will determine the places 5 to 10 in the Competition.

09.01.01.08. *If eleven teams subscribe:*

- Two groups: one of 6 teams, "a", and one of 5 teams, "b".
- Each group plays a single round robin.
- Teams ranked 1 and 2 of in groups "a" and "b" play a single round robin "c" in which the games among these four teams will also be considered as a played game for this round robin "c".
- Teams ranked 3, 4, 5 and 6 of both groups play a single round robin "d" in which the games between these teams will also be considered as a played game for this round robin "d".

- Teams ranked 1 to 4 in group "c" play the "Page System" finals.
- The final results of round robin "d" determine the places 5 to 11 in the Competition.

09.01.01.09. If twelve teams subscribe:

- Four groups "a", "b", "c" and "d", each one of 3 teams.
- Each group plays a single round robin.
- Two quarter final groups "e" and "f" will be created after a single round robin. Quarter final group "e" will be created from the teams ranked a1, b2, c2 and d1. Quarter final group "f" will be created from the teams ranked a2, b1, c1 and d2.
- Teams ranked 2 and 3 of both quarter final groups "e" and "f" play the extra game for qualification to "Page System" finals.
- Teams ranked first of quarter final groups "e" and "f" play the first semifinal game of "Page System", the winners of extra game of both quarter final groups "e" and "f" play second semifinal game of "Page System".
- Losers extra games of both quarter final groups "e" and "f" play for place 5.
- Fourth teams of both quarter final groups "e" and "f" play for place 7.
- Teams ranked 3 of groups "a", "b", "c" and "d" play a single round robin "g".
- Teams ranked first and second of group "g" play the game for 9th place, teams ranked third and fourth of group "g" play the game for 11th place.

09.01.01.10. If thirteen teams subscribe:

- Four groups: one of 4 teams "a", and three of 3 teams, "b", "c" and "d".
- Each group plays a single round robin.
- Two quarter final groups "e" and "f" will be created after a single round robin. Quarter final group "e" will be created from the teams ranked a1, b2, c2 and d1. Quarter final group "f" will be created from the teams ranked a2, b1, c1 and d2.
- Teams ranked 2 and 3 of both quarter final groups "e" and "f" play the extra game for qualification to "Page System" finals.
- Teams ranked first of quarter final groups "e" and "f" play the first semifinal game of "Page System", the winners of extra game of both quarter final groups "e" and "f" play second semifinal game of "Page System".
- Losers extra games of both quarter final groups "e" and "f" play for place 5.
- Fourth teams of both quarter final groups "e" and "f" play for place 7.
- Teams ranked 3 and 4 of groups "a", "b", "c" and "d" play a single round robin "g" in which the games between these teams of round "a" will also be considered as a played game for this round robin "g". The final results of round "g" will determine places 9 to 13 in the Competition.

09.01.01.11. If fourteen teams subscribe:

- Four groups: two of 4 teams "a", "b", and two of 3 teams, "c" and "d".
- Each group plays a single round robin.
- Two quarter final groups "e" and "f" will be created after a single round robin. Quarter final group "e" will be created from the teams ranked a1, b2, c2 and d1. Quarter final group "f" will be created from the teams ranked a2, b1, c1 and d2.
- Teams ranked 2 and 3 of both quarter final groups "e" and "f" play the extra game for qualification to "Page System" finals.
- Teams ranked first of quarter final groups "e" and "f" play the first semifinal game of "Page System", the winners of extra game of both quarter final groups "e" and "f" play second semifinal game of "Page System".
- Losers extra games of both quarter final groups "e" and "f" play for place 5.
- Fourth teams of both quarter final groups "e" and "f" play for place 7.
- Teams ranked 3 and 4 of fourth groups "a", "b", "c" and "d" play a single round robin "g" in which the games between these teams of rounds "a" and "b" will also be considered as a played game for this round "g". The final results of round "g" will determine places 9 to 14 in the Competition.

09.01.01.12. If fifteen teams subscribe:

- Four groups: three of 4 teams "a", "b", "c", and one of 3 teams, "d".
- Each group plays a single round robin.
- Two quarter final groups "e" and "f" will be created after a single round robin. Quarter final group "e" will be created from the teams ranked a1, b2, c2 and d1. Quarter final group "f" will be created from the teams ranked a2, b1, c1 and d2.
- Teams ranked 2 and 3 of both quarter final groups "e" and "f" play the extra game for qualification to "Page System" finals.
- Teams ranked first of quarter final groups "e" and "f" play the first semifinal game of "Page System", the winners of extra game of both quarter final groups "e" and "f" play second semifinal game of "Page System".
- Losers extra games of both quarter final groups "e" and "f" play for place 5.
- Fourth teams of both quarter final groups "e" and "f" play for place 7.
- Teams ranked 3 and 4 of fourth groups "a", "b", "c" and "d" play a single round robin "g" in which the games between these teams of rounds "a", "b" and "c" will also be considered as a played game for this round "g". The final results of round "g" will determine places 9 to 15 in the Competition.

09.01.01.13. If sixteen teams subscribe:

- Four groups "a", "b", "c" and "d", each one of 4 teams.
- Each group plays a single round robin.

- Two quarter final groups "e" and "f" will be created after a single round robin. Quarter final group "e" will be created from the teams ranked a1, b2, c2 and d1. Quarter final group "f" will be created from the teams ranked a2, b1, c1 and d2.
- Teams ranked 2 and 3 of both quarter final groups "e" and "f" play the extra game for qualification to "Page System" finals.
- Teams ranked first of quarter final groups "e" and "f" play the first semifinal game of "Page System", the winners of extra game of both quarter final groups "e" and "f" play second semifinal game of "Page System".
- Losers extra games of both quarter final groups "e" and "f" play for place 5.
- Fourth teams of both quarter final groups "e" and "f" play for place 7.
- Teams ranked 3 of fourth groups "a", "b", "c" and "d" play a single round robin "g". The final results of round robin "g" will determine places 9 to 12 in the Competition.
- Then teams ranked 4 of fourth groups "a", "b", "c" and "d" play a single round robin "h". The final results of round robin "h" will determine places 13 to 16 in the Competition.

09.01.01.14. If seventeen teams subscribe:

- Four groups: one of 5 teams "a", and three of 4 teams, "b", "c" and "d".
- Each group plays a single round robin.
- Two quarter final groups "e" and "f" will be created after a single round robin. Quarter final group "e" will be created from the teams ranked a1, b2, c2 and d1. Quarter final group "f" will be created from the teams ranked a2, b1, c1 and d2.
- Teams ranked 2 and 3 of both quarter final groups "e" and "f" play the extra game for qualification to "Page System" finals.
- Teams ranked first of quarter final groups "e" and "f" play the first semifinal game of "Page System", the winners of extra game of both quarter final groups "e" and "f" play second semifinal game of "Page System".
- Losers extra games of both quarter final groups "e" and "f" play for place 5.
- Fourth teams of both quarter final groups "e" and "f" play for place 7.
- Teams ranked 3 of fourth groups "a", "b", "c" and "d" play a single round robin "g". The final results of round robin "g" will determine places 9 to 12 in the Competition.
- Teams ranked 4 and 5 of groups "a", "b", "c" and "d" play a single round robin "h" in which the games between these teams of round "a" will also be considered as a played game for this round robin "h". The final results of round "h" will determine places 13 to 17 in the Competition.

09.01.01.15. If eighteen teams subscribe:

- Four groups: two of 5 teams "a", "b", and two of 4 teams, "c" and "d".
- Each group plays a single round robin.
- Two quarter final groups "e" and "f" will be created after a single round robin. Quarter final group "e" will be created from the teams ranked a1, b2, c2 and d1. Quarter final group "f" will be created from the teams ranked a2, b1, c1 and d2.
- Teams ranked 2 and 3 of both quarter final groups "e" and "f" play the extra game for qualification to "Page System" finals.
- Teams ranked first of quarter final groups "e" and "f" play the first semifinal game of "Page System", the winners of extra game of both quarter final groups "e" and "f" play second semifinal game of "Page System".
- Losers extra games of both quarter final groups "e" and "f" play for place 5.
- Fourth teams of both quarter final groups "e" and "f" play for place 7.
- Teams ranked 3 of fourth groups "a", "b", "c" and "d" play a single round robin "g". The final results of round robin "g" will determine places 9 to 12 in the Competition.
- Teams ranked 4 and 5 of groups "a", "b", "c" and "d" play a single round robin "h" in which the games between these teams of round "a" and "b" will also be considered as a played game for this round robin "h". The final results of round "h" will determine places 13 to 18 in the Competition.

09.01.01.16. If nineteen teams subscribe:

- Four groups: three of 5 teams "a", "b", "c", and one of 4 teams, "d".
- Each group plays a single round robin.
- Two quarter final groups "e" and "f" will be created after a single round robin. Quarter final group "e" will be created from the teams ranked a1, b2, c2 and d1. Quarter final group "f" will be created from the teams ranked a2, b1, c1 and d2.
- Teams ranked 2 and 3 of both quarter final groups "e" and "f" play the extra game for qualification to "Page System" finals.
- Teams ranked first of quarter final groups "e" and "f" play the first semifinal game of "Page System", the winners of extra game of both quarter final groups "e" and "f" play second semifinal game of "Page System".
- Losers extra games of both quarter final groups "e" and "f" play for place 5.
- Fourth teams of both quarter final groups "e" and "f" play for place 7.
- Teams ranked 3 of fourth groups "a", "b", "c" and "d" play a single round robin "g". The final results of round robin "g" will determine places 9 to 12 in the Competition.
- Teams ranked 4 and 5 of groups "a", "b", "c" and "d" play a single round robin "h" in which the games between these teams of round "a", "b" and "c" will also be considered as a played game for this round robin "h". The final results of round "h" will determine places 13 to 19 in the Competition.

09.01.01.17. If twenty teams subscribe:

- Four groups "a", "b", "c" and "d", each one of 5 teams.

- Each group plays a single round robin.
- Two quarter final groups "e" and "f" will be created after a single round robin. Quarter final group "e" will be created from the teams ranked a1, b2, c2 and d1. Quarter final group "f" will be created from the teams ranked a2, b1, c1 and d2.
- Teams ranked 2 and 3 of both quarter final groups "e" and "f" play the extra game for qualification to "Page System" finals.
- Teams ranked first of quarter final groups "e" and "f" play the first semifinal game of "Page System", the winners of extra game of both quarter final groups "e" and "f" play second semifinal game of "Page System".
- Losers extra games of both quarter final groups "e" and "f" play for place 5.
- Fourth teams of both quarter final groups "e" and "f" play for place 7.
- Teams ranked 3 of fourth groups "a", "b", "c" and "d" play a single round robin "g". The final results of round robin "g" will determine places 9 to 12 in the Competition.
- Then teams ranked 4 of fourth groups "a", "b", "c" and "d" play a single round robin "h". The final results of round robin "h" will determine places 13 to 16 in the Competition.
- Then teams ranked 5 of fourth groups "a", "b", "c" and "d" play a single round robin "i". The final results of round robin "h" will determine places 17 to 20 in the Competition.

09.01.01.18. If twenty-one teams subscribe:

- Four groups: one of 6 teams "a", and three of 5 teams, "b", "c" and "d".
- Each group plays a single round robin.
- Two quarter final groups "e" and "f" will be created after a single round robin. Quarter final group "e" will be created from the teams ranked a1, b2, c2 and d1. Quarter final group "f" will be created from the teams ranked a2, b1, c1 and d2.
- Teams ranked 2 and 3 of both quarter final groups "e" and "f" play the extra game for qualification to "Page System" finals.
- Teams ranked first of quarter final groups "e" and "f" play the first semifinal game of "Page System", the winners of extra game of both quarter final groups "e" and "f" play second semifinal game of "Page System".
- Losers extra games of both quarter final groups "e" and "f" play for place 5.
- Fourth teams of both quarter final groups "e" and "f" play for place 7.
- Teams ranked 3 of fourth groups "a", "b", "c" and "d" play a single round robin "g". The final results of round robin "g" will determine places 9 to 12 in the Competition.
- Then teams ranked 4 of fourth groups "a", "b", "c" and "d" play a single round robin "h". The final results of round robin "h" will determine places 13 to 16 in the Competition.
- Teams ranked 5 and 6 of groups "a", "b", "c" and "d" play a single round robin "i" in which the games between these teams of round "a" will also be considered as a played game for this round robin "i". The final results of round "i" will determine places 17 to 21 in the Competition.

09.01.01.19. If twenty-two teams subscribe:

- Four groups: two of 6 teams "a", "b", and two of 5 teams, "c" and "d".
- Each group plays a single round robin.
- Two quarter final groups "e" and "f" will be created after a single round robin. Quarter final group "e" will be created from the teams ranked a1, b2, c2 and d1. Quarter final group "f" will be created from the teams ranked a2, b1, c1 and d2.
- Teams ranked 2 and 3 of both quarter final groups "e" and "f" play the extra game for qualification to "Page System" finals.
- Teams ranked first of quarter final groups "e" and "f" play the first semifinal game of "Page System", the winners of extra game of both quarter final groups "e" and "f" play second semifinal game of "Page System".
- Losers extra games of both quarter final groups "e" and "f" play for place 5.
- Fourth teams of both quarter final groups "e" and "f" play for place 7.
- Teams ranked 3 of fourth groups "a", "b", "c" and "d" play a single round robin "g". The final results of round robin "g" will determine places 9 to 12 in the Competition.
- Then teams ranked 4 of fourth groups "a", "b", "c" and "d" play a single round robin "h". The final results of round robin "h" will determine places 13 to 16 in the Competition.
- Teams ranked 5 and 6 of groups "a", "b", "c" and "d" play a single round robin "i" in which the games between these teams of round "a" and "b" will also be considered as a played game for this round robin "i". The final results of round "i" will determine places 17 to 22 in the Competition.

09.01.01.20. If twenty-three teams subscribe:

- Four groups: three of 6 teams "a", "b", "c", and one of 5 teams, "d".
- Each group plays a single round robin.
- Two quarter final groups "e" and "f" will be created after a single round robin. Quarter final group "e" will be created from the teams ranked a1, b2, c2 and d1. Quarter final group "f" will be created from the teams ranked a2, b1, c1 and d2.
- Teams ranked 2 and 3 of both quarter final groups "e" and "f" play the extra game for qualification to "Page System" finals.
- Teams ranked first of quarter final groups "e" and "f" play the first semifinal game of "Page System", the winners of extra game of both quarter final groups "e" and "f" play second semifinal game of "Page System".
- Losers extra games of both quarter final groups "e" and "f" play for place 5.
- Fourth teams of both quarter final groups "e" and "f" play for place 7.

- Teams ranked 3 of fourth groups "a", "b", "c" and "d" play a single round robin "g". The final results of round robin "g" will determine places 9 to 12 in the Competition.
- Then teams ranked 4 of fourth groups "a", "b", "c" and "d" play a single round robin "h". The final results of round robin "h" will determine places 13 to 16 in the Competition.
- Then teams ranked 5 of fourth groups "a", "b", "c" and "d" play a single round robin "i". The final results of round robin "i" will determine places 17 to 20 in the Competition.
- Then teams ranked 6 of thirds groups "a", "b" and "c" play a single round robin "j". The final results of round robin "j" will determine places 20 to 23 in the Competition.

09.01.01.24. If twenty-four teams subscribe:

- Eight groups "a", "b", "c", "d", "e", "f", "g" and "h", each one of 3 teams.
- Each group plays a single round robin.
- Teams ranked 2 of each group will play extra game for qualification to quarter final groups (2a – 2d, 2b – 2c, 2e – 2h and 2f – 2g).
- Two quarter final groups "i" and "j" will be created after a single round robin.
- Quarterfinal group "i" will be created from the teams' ranked a1, d1, e1, h1 and winners extra games 2b – 2c and 2f – 2g.
- Quarter final group "j" will be created from the teams' ranked b1, c1, f1, g1 and winners extra games 2a – 2d and 2e – 2h.
- Teams ranked 2 and 3 of both quarter final groups "i" and "j" play the extra game for qualification to "Page System" finals.
- Teams ranked first of quarter final groups "i" and "j" play the first semifinal game of "Page System", the winners of extra game of both quarter final groups "i" and "j" play second semifinal game of "Page System".
- Losers extra games of both quarter final groups "i" and "j" play for place 5.
- Fourth teams of both quarter final groups "i" and "j" play for place 7.
- Fifth teams of both quarter final groups "i" and "j" play for place 9.
- Sixth teams of both quarter final groups "i" and "j" for place 11.
- Losers extra games for qualification to quarter final groups (2a – 2d, 2b – 2c, 2e – 2h and 2f – 2g) play a single round robin "k". The final results of round robin "k" will determine places 13 to 16 in the Competition.
- Teams ranked 3 of groups "a", "b", "c", "d", "e", "f", "g" and "h", play a single round robin "l". The final results of round robin "l" will determine places 17 to 24 in the Competition.

09.01.02. For European Competitions other than Championships, the following format shall apply:

Number of Teams Subscribing: (not including Cup "A" Defender)	4 to 11	12	13 to 21	22 to 29	30 to 37	38 to 45	46 to 52
Cup "A"	4 to 11 plus DEF	8 plus DEF	9 plus DEF	9 plus DEF	9 plus DEF	9 plus DEF	9 plus DEF
Cup "B"	na	4	4 to 12	8	8	8	8
Cup "C"	na	na	na	5 to 12	8	8	8
Cup "D"	na	na	na	na	5 to 12	8	8
Cup "E"	na	na	na	na	na	5 to 12	8
Cup "F"	na	na	na	na	na	na	5 to 11

09.01.02.01. If no less than four and no more than eleven teams subscribe, not including the possible defending Champion, these will be allocated in one Division:

- a European Cup "A", with all registered teams, plus the possible defending Champion.

09.01.02.02. If twelve teams subscribe, not including the possible defending Champion, these will be allocated between two Divisions:

- a European Cup "A", with a maximum of eight teams, plus the possible defending Champion, and
- a European Cup "B", with the remaining number of teams.

09.01.02.03. If thirteen to twenty-one teams subscribe, not including the possible defending Champion, these will be allocated between two Divisions:

- a European Cup "A", with a maximum of nine teams, plus the possible defending Champion, and
- a European Cup "B", with the remaining number of teams.

09.01.02.04. If twenty-two to twenty-nine teams subscribe, not including the possible defending Champion, these will be allocated between three Divisions:

- a European Cup "A", with a maximum of nine teams, plus the possible defending Champion,
- a European Cup "B", with a maximum of eight teams and
- a European Cup "C", with the remaining number of teams.

09.01.02.05. If thirty to thirty-seven teams subscribe, not including the possible defending Champion, these will be allocated between four Divisions:

- a European Cup "A", with a maximum of nine teams, plus the possible defending Champion,
- a European Cup "B", with a maximum of eight teams,
- a European Cup "C", with a maximum of eight teams and
- a European Cup "D", with the remaining number of teams.

09.01.02.06. If twenty-eight to forty-five teams subscribe, not including the possible defending Champion, these will be allocated between five Divisions:

- a European Cup "A", with a maximum of nine teams, plus the possible defending Champion,
- a European Cup "B", with a maximum of eight teams,
- a European Cup "C", with a maximum of eight teams,
- a European Cup "D", with a maximum of eight teams and
- a European Cup "E", with the remaining number of teams.

09.01.02.07. If forty-six to fifty-two teams subscribe, not including the possible defending Champion, these will be allocated between six Divisions:

- a European Cup "A", with a maximum of nine teams, plus the possible defending Champion,
- a European Cup "B", with a maximum of eight teams,
- a European Cup "C", with a maximum of eight teams,
- a European Cup "D", with a maximum of eight teams,
- a European Cup "E", with a maximum of eight teams and
- a European Cup "F", with the remaining number of teams.

09.01.03. The allocation of teams within the Divisions of a Competition is made according to their rating in said Competition, teams being allotted to the Divisions of a Competition in the descending order of their rating and in the descending order of the Divisions.

09.01.04. The allocation of teams within the Divisions of a Competition is effected immediately after the closing date for subscriptions as stated in article 08 and is notified to all Affiliated Federations.

09.01.05. For the allocation of teams, their rating represents only their hierarchy within the Competition and not a right to be allotted in the Division they are rated in.

09.01.06. Once the allocation of teams has been effected, for teams having not subscribed, and thus having not been allotted, the procedure of article 09.05.03 is applied.

09.01.07. Once the allocation of teams has been effected the format of the Competition shall be considered final and not subject to change.

09.01.08. In the case when a team withdraws, either by its own fact or as a result of not respecting the conditions of eligibility or of participation, after the notification of the allocation of teams as stated in article 09.01.04, and before the 30 days deadline as stated in article 12.02:

09.01.08.01. The withdrawing team is retired from the allocation of teams and considered as having not subscribed, the procedure of article 09.05. is applied, without prejudice of the possible financial penalties.

09.01.08.02. If such withdrawal concerns the A Division of Championships Senior Men or Women and is established within 30 days after the notification of the allocation, the procedure of promotion of article 09.02.02 is applied, and the allocation of teams between Divisions is modified accordingly.

09.01.08.03. If such withdrawal does not enter within the scope of article 09.01.08.02, the allocation of teams between Divisions is not modified further.

PROMOTION AND RELEGATION

09.02. Promotion and relegation of teams occur in the following cases:

09.02.01. As a consequence of the final standing of a team in Competition:

09.02.01.01. *Deleted (no promotion and/or relegation in Championships)*

09.02.01.02. Between all Divisions of all Competitions *except Championships*, the last ranked team of a Division is relegated to the immediately lower Division and the first ranked team of a Division is promoted to the higher Division.

09.02.01.03. Such promotions and relegations take effect immediately after the completion of the Competition.

09.02.02. Deleted

09.02.03. As a consequence of the non participation of a team to a Competition to which it subscribed:

09.02.03.01. A team that does not effectively take part to, or withdraws from a Competition to which it subscribed is relegated to the Division immediately lower than its Division of origin within said Competition, at a rank immediately under the lowest ranked team of the Division of relegation. The highest ranked team of the lower Division is then promoted to the higher Division as replacement. However, a team having been already, for a given year, relegated from the higher Division in application of article 09.02.01. can not be promoted the same year to the higher Division in application of article 09.02.03.

09.02.03.02. When several teams from the same Division are relegated in application of article 09.02.03.01, they are relegated in the lower Division in the order of their rating in the higher Division. The same number of teams is promoted from the lower Division, in the order of their rating in the lower Division.

09.02.03.03. In the application of article 09.02.03.01, relegations take effect:

09.02.03.03.01. Immediately once the non participation is established, when such relegation is effected under article 09.01.08,

09.02.03.03.02. After the completion of the Competition, when such relegation is effected under article 12.02.

09.02.03.04. In the application of article 09.02.03.01, promotions take effect after the completion of the Competition.

09.02.04. As a consequence of the non subscription of a team to a Competition to which it was eligible:

09.02.04.01. A team that does not subscribe in a given Competition, in which it was eligible to take part, is relegated to the Reserve Division of said Competition.

09.02.04.02. When several teams are relegated in application of article 09.02.04.01, they are relegated in the Reserve Division in the order of their rating in their Divisions of origin.

09.02.04.03. In the application of article 09.02.04.01, relegations are effected at the closing date for subscriptions as defined in article 08.04 and take effect immediately.

09.02.04.04. The Reserve Division of a Competition is taken into consideration only for relegation in application of article 09.02.04. There is no relegation to, or promotion from, the Reserve Division for the application of articles 09.02.01, 09.02.02 and 09.02.03.

RATINGS

09.03. The rating of a team in a given Competition is the basis for determination of its qualification for the next Competition. The rating of a team in a given Competition is primarily defined, for said Competition, by the Division in which the team has played and its rank inside this Division. For hierarchy purpose, the Division has precedence on the rank. For example: rating A5 is higher than rating B3. The rating of teams for the next Competition is determined after all ranks in all Divisions of a given Competition are known, as follows:

RATINGS - DIVISION "X"		
Div.	rank	rating
X	1st	X1
	2nd	X2
	3rd	X3
	4th	X4
	5th	X5
	6th	X6
	7th	X7
	8th	X8
	9th	X9
	10th	X10
	11th	X11
	12th	X12

09.03.01. For the “A” Division of Cup Competitions the rank of a defending Champion is neutralized for the determination of the rating as per article 04.04. If the possible defending Champion has also the first Place in the Competition, he receives an A0 rating. The first ranked team, if not the defending Champion, receives an A1 rating as Winner, this rating being transmitted to the team that will represent the Federation in next Competition, and an A0 rating as the new defending Champion.

RATING - Cup Division A			RATING - Cup Division A		
Defender has 1st Place			Defender has NOT 1st Place		
Div.	Rank	rating	Div.	Rank	rating
A	1st	A1	A	1st	A0 + A1
	2nd	A2		2nd	A2
	3rd	A3		3rd	A3
	4th	A4		4th	A4
	5th	A5		5th	A5
	6th	A6		6th	A6
	7th	A7		7th	A7
	8th	A8		8th	A8
	9th	A9		9th	A9
	10th	A10		10th	A10
	11th	A11		11th	A11
DEF.	A0	DEF.	na		

NOTE: Ranks determined WITHOUT taking the Defending Champion into account

09.03.02. In Cup Competitions, and except for a Title Holder as Defending Champion, the rating is obtained by a team but is attributed to the Federation of belonging of said team. This rating is then the rating of the team that represents said federation in next Competition.

09.04. Once the primary ratings have been defined for each Competition according to article 09.03, promotions and relegations are effected as follows:

09.04.01. The ratings of teams promoted and relegated as a consequence of their final standings in Competition as per article 09.02.01, are determined as follows:

09.04.01.01. When one team is promoted and one team is relegated: The last ranked team of the higher Division and the first ranked team of the lower Division exchange their ratings:

09.04.01.02. When two teams are promoted and two teams are relegated: The two last ranked team of the higher Division and the two first ranked team of the lower Division exchange respectively their ratings.

Promotion and relegation of one team
(article 09.04.01.01)

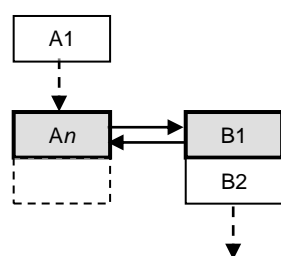

Promotion and relegation of two team
(article 09.04.01.02)

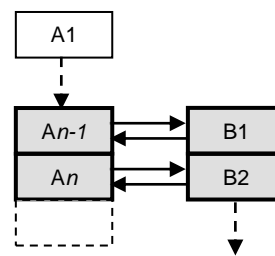

09.04.01.03. For the determination of the last ranked team or teams, all teams appearing in the standings of the Competition are taken into account, this including teams having effectively taken part to the Competition and teams mentioned in the Competition’s Schedule or standings but not having effectively taken part as per article 12.02.

09.04.02. The ratings of teams promoted and relegated as a consequence of non participation after subscription in application of article 09.02.03, are determined as follows:

09.04.02.01. The first team or teams ranked in the lower Division after the team or teams relegated from the higher Division in application of article 09.04.01 are promoted to the higher Division in the limit of the number

of places vacant, in the order of their initial rating, after the last ranked team of the higher division, and receive a new rating in the higher Division.

09.04.02.02. The teams relegated from the higher Division are transferred in the lower Division in the order of their initial ranking in the higher Division, after the last ranked team of the lower Division, and the teams of the lower Division are re-rated according to this new ranking.

09.04.02.03. The procedure of articles 09.04.02.01 and 09.04.02.02 must be effected after the procedure of article 09.04.01, and shall not affect the teams promoted and relegated according to said article 09.04.01.

Promotion and relegation of teams as per article 09.04.02

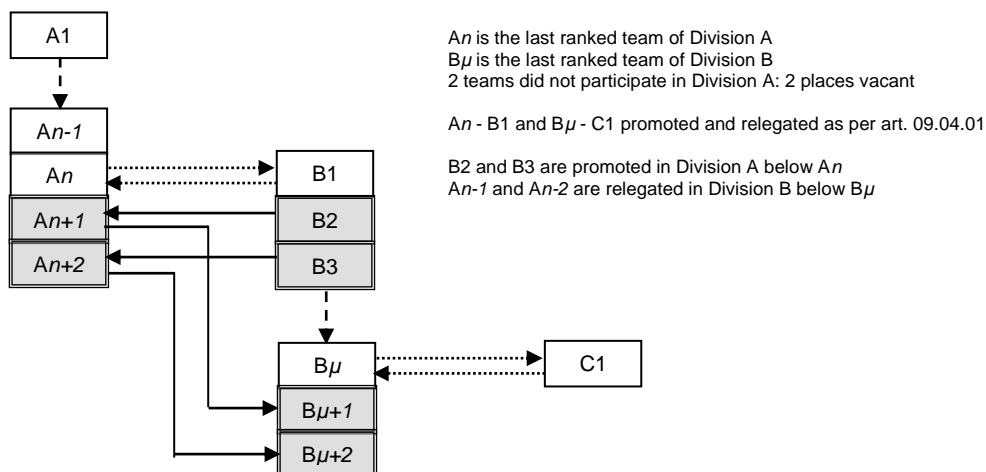

09.04.03. Once all promotions and relegations as stated in articles 09.04.01, 09.04.02 and 09.04.03 have been effected, the ratings of Divisions where changes have occurred are determined again according to article 09.03. These ratings are then final for the next Competition Year

09.05. Ratings can be altered during the Competition Year in the following circumstances:

09.05.01. Deleted

09.05.02. Teams that subscribe for the first time in a given European Competition receive a specific N rating, their rank within this rating being defined in the order of arrival of subscriptions. Hierarchically the N rating is below the rating of the lowest existing Division for said Competition and below the rating of the Reserve Division.

09.05.03. Teams that have not subscribed to a Competition to which they were eligible and are relegated to the Reserve Division in application of article 09.02.04 are ranked in the Reserve Division on top of the teams already in the Reserve Division and in the order of their ratings in their Divisions of origin. Once all teams subject to article 09.02.04 have been transferred to the Reserve Division ratings in the Division are re-determined as per article 09.03.

Relegation in the Reserve Division as per article 09.05.03

Before application of article 09.05.03:

In Division A : 2 teams *Aα* and *Aδ* did not subscribe
 In Division B: 1 team *Bγ* did not subscribe
 In Division C: 1 team *Cβ* did not subscribe
 3 teams *R1* *R2* and *R3* are already in Reserve Division

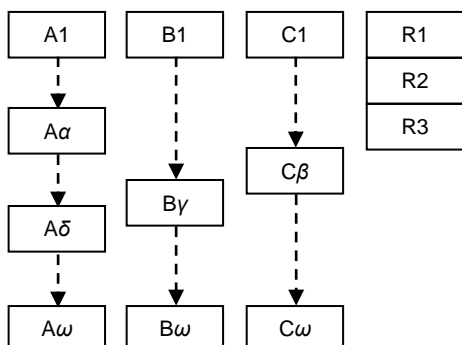

Application of article 09.05.03:

Aα, *Aδ*, *Bγ*, *Cβ* are relegated in reserve Division in that order and rated in Reserve Division
 Teams already in Reserve Division are shifted to lower ratings

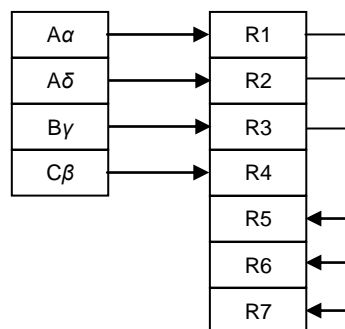

09.05.04. Teams that withdraw, are retired or do not effectively take part to the Competition are relegated in application of article 09.02.03 and receive a provisional rating in the Division of relegation, this rating starting immediately the last rated team of said Division. This provisional rating may be altered if other relegations are effected to said Division, as the hierarchical order of the ratings of relegated teams in the Division of relegation must be the same as the hierarchical order of their ratings in their Division of origin.

Relegations as per article 09.05.04

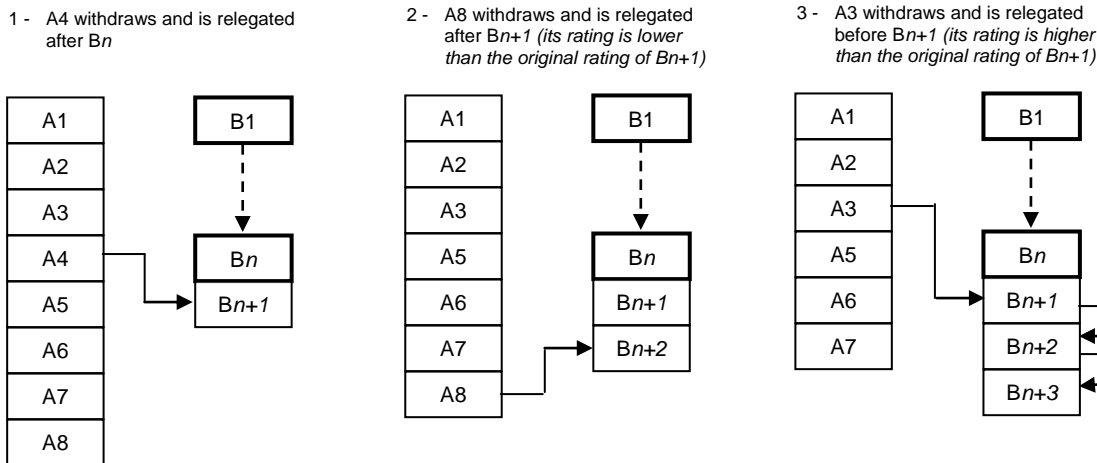

09.06. The right of a team for promotion to a higher Division in next Competition is not absolute, but is contingent to the actual number of teams having registered to said Competition. If after the closing of subscriptions and the application of the Rules for allocation the promotion of the team is not possible said team can not claim suffering a tort from this situation.

COMPETITION SYSTEM

10. 01. All European Competitions shall be concluded by the following "Page System":

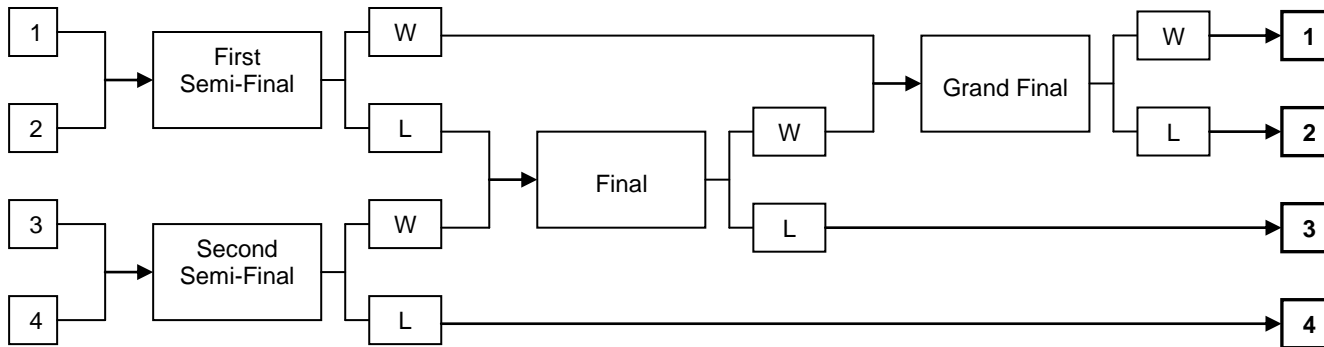

First semi-final: The teams ranked first and second shall play for a place in the grand final.

Second semi-final: The teams ranked third and fourth shall play for a place in the final. The loser is the fourth of the Competition.

Final: The loser of the first semi-final and the winner of the second semi-final shall play for the second place in the grand final. The loser is the third of the Competition.

Grand Final: The winner of the first semi-final and the winner of the final shall play for the first place in the Competition. The loser is second of the Competition

10.02. Qualification to the Page System will be conducted as follows:

10.02.01. with 4 teams: Double round robin "a".
Teams ranked 1 to 4 play the "Page System" finals.

10.02.02. with 5 teams: Double round robin "a".
Teams ranked 1 to 4 play the "Page System" finals.

Team ranked 5 will be 5th in the Competition.

10.02.03. with 6 teams: Single round robin "a".

Teams ranked 1 to 4 play the "Page System" finals.

Teams ranked 5 and 6 play against each other to determine places 5 and 6.

10.02.04. with 7 teams: Single round robin "a".

Teams ranked 1 to 4 play the "Page System" finals.

Teams ranked 5 to 7 play a single round robin "b" to determine places 5, 6, and 7.

10.02.05. with 8 teams: Single round robin "a".

Teams ranked 1 to 4 play the "Page System" finals.

Teams ranked 5 and 6 will respectively be 5th and 6th in the Competition.

Teams ranked 7 and 8 play against each other to determine places 7 and 8.

10.02.06. with 9 teams: Single round robin "a".

Teams ranked 1 to 4 play the "Page System" finals.

Teams ranked 5, 6, 7, 8 and 9 will respectively be 5th, 6th, 7th, 8th and 9th in the Competition.

10.02.07. with 10 teams: Two groups "a" and "b" both of five teams.

Each group plays a single round robin.

Then teams ranked 1, 2 and 3 of both groups play a single round robin "c" in which the games between these teams of the first round robins "a" and "b" will also be considered as a played game for this round robin "c".

Teams ranked 4 and 5 of both groups play a single round robin "d" in which the games between these teams of the first round robins "a" and "b" will also be considered as a played game for this round robin "d".

Teams ranked 1 to 4 of round robin "c" then play the "Page System" finals.

Teams ranked 5 and 6 of round robin "c" will respectively be 5th and 6th in the Competition.

The final results of round robin "d" will determine the places 7 to 10 in the Competition.

10.02.08. with 11 teams: Two groups: one of 5 teams "a" and one of 6 teams "b".

Each group plays a single round robin.

Then teams ranked 1 and 2 of both groups play a single round robin "c" in which the games between these teams of the first round robins "a" and "b" will also be considered as a played game for this round robin "c" and then the "Page System" finals.

Teams ranked 3 and 4 of both groups play a single round robin "d" in which the games between these teams of the first round robins "a" and "b" will also be considered as a played game for this round robin "d" to determine the places 5 to 8.

Teams ranked 5 and 6 of both groups play a single round robin "e" in which the games between these teams of the first round robins "a" and "b" will also be considered as a played game for this round robin "e" to determine the places 9 to 11.

10.02.09. with 12 teams: Two groups "a" and "b" both of 6 teams.

Each group plays a single round robin.

Then teams ranked 1 and 2 of both groups play a single round robin "c" in which the games between these teams of the first round robins "a" and "b" will also be considered as a played game for this round robin "c" and then the "Page System" finals.

Teams ranked 3 of both groups play a single round robin "d" to determine the places 5 and 6 (toss).

Teams ranked 4 of both groups play a single round robin "e" to determine the places 7 and 8 (toss).

Teams ranked 5 of both groups play a single round robin "f" to determine the places 9 and 10 (toss).

Teams ranked 6 of both groups play a single round robin "g" to determine the places 11 and 12 (toss).

NUMBER OF GAMES IN TERMS OF NUMBER OF TEAMS									
Number of Games	Number of Teams								
	4	5	6	7	8	9	10	11	12
Qualification	12	20	15	21	28	36	20	25	30
Classification	-	-	1	3	1	-	13	10	8
Page System	4	4	4	4	4	4	4	4	4
Total Games	16	24	20	28	33	40	37	39	42

10.02.10. The above formats apply for Fastpitch Competitions. For Slowpitch Competitions [see art. 41.03](#).

10.03. The composition of the groups is made up by the Technical Commission as follows, based on the rating of the Federations' teams.

Group "a"	Group "b"
1	2
4	3
5	6
8	7
9	10
12	11

RESOLUTION OF TIES

11. When teams are tied after a round robin the tie shall be resolved by following the procedure for resolution of ties of the ISF Technical and Procedural Code.

Procedural note: The procedure is applied step by step for all teams tied. When the tie has been resolved for one team, and the other teams remain tied, the procedure is resumed from the first step for the remaining teams tied until no more tie exists.

Application of the Procedure:

IF NO GAME OF THE PAGE SYSTEM IS PLAYED: Refer to the Results of the Round Robin

AS SOON AS A GAME HAS BEEN PLAYED IN THE PAGE SYSTEM: If it results in the elimination of a team, this Game is validated.

Note: This concerns the Second Semi Final, the Final, and the Grand Final. In the First Semi Final no Team is eliminated from the Page System

IF FIRST SEMI FINAL ONLY IS PLAYED: No Team is eliminated, refer to the Ranking of the Round Robin for determination of the Final Places.

IF SECOND SEMI FINAL ONLY IS PLAYED: Loser of Second Semi Final has 4th Place, refer to the ranking of Round Robin for 1st, 2nd and 3rd Places (Winner of Second Semi Final has 3rd Place).

IF FIRST AND SECOND SEMI FINAL ARE PLAYED: Loser of Second Semi Final has 4th Place, refer to the ranking of Round Robin for 1st, 2nd and 3rd Places (Winner of Second Semi Final has 3rd Place).. The result of First Semi Final is not taken in account as this game can not be validated

Note: It can therefore be sometimes recommended to play Second Semi Final before First Semi Final, as the result of Second Semi Final allows to determine the ranking for 4th place.

IF SEMI FINALS AND FINAL ARE PLAYED: Loser of Final has 3rd Place, Loser of Second Semi Final has already 4th Place, refer to the Ranking of the other Teams in the Round Robin for determination of 1st and 2nd Places. (The result of First Semi Final is also not taken in account as this game can not be validated.

Note: When referring to the ranking of Teams in the Round Robin, refer to the relative ranking of teams between them and not to their absolute ranking

Example:

The ranking of the Round Robin is 1:A, 2:B, 3:C, 4:D (A, B, C, D)

- B wins the First Semi Final (A-B), D wins the Second Semi Final(C-D). C has the 4th Place of the Competition.

- If the Competition is disrupted at this stage the Final Places will be: A, B, D, C.

- The Final (A-D) is won by D. A has the 3rd Place of the Competition.

- If the Competition is disrupted at this stage the Final Places will be: B, D, A, C.

PROGRAM OF COMPETITIONS

12.01. The Technical Commission establishes the provisional Competition Schedule and sends it to the Organizers and the Members of the Executive Council, who may suggest changes. Thereafter, the Technical Commission shall publish the final official version on May 15th.

12.02. If within 30 days prior to the start of a Competition a team cancels its participation or does not show up at the Competition this team will however be taken into account in the standings of the Competition as follows :

12.02.01. The game schedule will not be changed unless special circumstances occur, all games due to be played by that team shall be forfeited.

12.02.02. If the game schedule is changed, such team shall be kept in the standings of said competition for determination of the rankings.

12.03. The teams shown first in the list of games of the Competition Schedule will be considered to be "the home team". A "toss" is only carried if mentioned in the Competition System.

PLAYING RULES

13. The games of European Competitions shall be played in accordance with the Playing Rules and the Technical & Procedural Code of the International Softball Federation (ISF) unless otherwise stated in these articles.

PLAYERS

14.01. Each team shall be made up of a minimum of nine (9) players, in Fastpitch, or ten players, in Coed Slowpitch, who shall stay for the entire duration of the tournament, and a maximum of seventeen (17) players, in Fastpitch, or eighteen (18) players, in Coed Slowpitch. The passport or ID card of the players shall be checked during the technical meeting. At that moment each team must be present and represented by at least nine (9) players, in Fastpitch, or ten players, in Coed Slowpitch.

14.02. If a team of less than seventeen players, in Fastpitch, or eighteen players, in Coed Slowpitch but not less than nine players, in Fastpitch, or ten players, in Coed Slowpitch, arrives at the Tournament, the team may request permission of the Technical Committee to complete the group of players after the beginning of the Competition. This request must be made in writing during the ID control at the Competition. The request must contain the name(s), surname(s) and the passport or ID card number of the players concerned. The request will not be accepted if additional players arrive after the round robin games.

14.03. No foreign players will be accepted as being eligible for European Championships.

14.04. Deleted.

14.05.01. A foreign player for the purpose of article 14.03 is a person not of the same nationality as the Federation represented by the National Team.

14.05.02. Deleted.

14.05.03. The nationality of every player will be determined by a passport or an I.D. card, issued by a national authority of an ESF member country, and giving proof of citizenship, which has to be presented at the technical meeting, to the exclusion of any other document.

14.05.04. A player who is a national of two or more countries at the same time may represent either one of them, as he/she may elect. However, after having represented one country of the resort of the ESF, in an ESF competition, or any country in any competition as referred to in By-Law of article 42 of the Olympic Charter, he/she may not represent another country of the resort of the ESF in an ESF competition unless he/she meets the conditions set forth in article CR 14.05.05 below that apply to persons who have changed their nationality or acquired a new nationality.

14.05.05. A player who has represented one country of the resort of the ESF in an ESF competition, or any country in any competition as referred to in By-Law of article 42 of the Olympic Charter, and who changed his/her nationality, may participate in a competition to represent his/her new country of the resort of the ESF in an ESF competition provided that at least three years have passed since the player last represented his/her former country. This period may be reduced or even cancelled with the agreement of the national federations concerned, by the ESF Executive Council, which takes into account the circumstances of each case.

14.05.06. Cases not covered by articles 14.05.04 and 14.05.05 shall be dealt with in accordance with the By-Law of article 42 of the Olympic Charter.

14.06.01. Within the frame of the present Regulations, a Club is defined as an entity that consists of a group of softball players, all of whom are citizens of ESF-member countries.

14.06.02. For purposes of determining player eligibility in ESF Cup Competitions, a Pick-Up player is defined to be a player who is not an otherwise bona fide member of a club that has qualified for participation in an ESF Cup Competition.

14.06.03. Notwithstanding the player restrictions imposed in the definition of a Club, each Club that qualifies for participation in an ESF Cup Competition shall be entitled to include a maximum of three (3) Pick-Up players on its final competition roster for the Cup Competition.

14.06.04. For the European Cup Co-ed Slowpitch (ECCS), the maximum number of Pick-Up Players on a team's final Competition Roster shall be four (4) limited to two (2) female and two (2) male.

14.06.05. For each Pick-Up Player listed in the Application Form for Licences (C.R. 16.02), the Club has to pay a fee, which amount is indicated in the Financial Appendix. The sum shall be received by the ESF Treasurer at the latest thirty (30) days before the start of the Competition. Late payment of the fee is subject to the assessment of a penalty, which amount is determined by the Executive Council.

Interpretation Note for article 14.06: There are no practical eligibility restrictions on Pick-Up players - they may come from another club within the same National Federation, from other ESF-affiliated federations, or from any other country in the world. The only restriction on their use is that they must be identified as Pick-Up players on the Application for Player Licenses that the club must submit to the ESF prior to the competition. To allow for possible injuries or other extenuating circumstances, there is no theoretical limit on the number of players that a club may identify as Pick-Up players on its Application for Player Licenses - the limit of three will apply to the final competition roster that is submitted during the ID Control. The term "bona fide" player means a player (a) that is a citizen of a country that has an ESF Affiliated Federation and (b) who is by that Affiliated Federation's requirements a member of a Club or eligible to play for such Club in their national competition in the current year. Any player that is not a bona fide player is a Pick-up Player.

14.07.01. For European Competitions the qualification inside a category of age is determined as of the 31st of December of the year of the Competition, as follows:

Category of Age	Age
Minime	10 to 13
Cadet	14 to 16
Junior	17 to 19
Under 22	20 to 22
Senior	23 and more

14.07.02. A player who has not yet reached the minimum age for a category of age may qualify in this category of age if he/she has the following minimum required age, determined at the first day of the competition: ten (10) years for Cadet, fourteen (14) years for Juniors, seventeen (17) years for Under 22 and Seniors.

14.07.03. The qualification of Players in a Category of Age is determined as follows:

QUALIFICATION OF PLAYERS IN A CATEGORY OF AGE ACCORDING TO THEIR BIRTH DATE COMPETITIONS 2011														
Player born between January 1 st and December 31 st of Year:	1988 and before	1989	1990	1991	1992	1993	1994	1995	1996	1997	1998	1999	2000	2001
Age of Player at December 31 st 2011:	23 and more	22	21	20	19	18	17	16	15	14	13	12	11	10
SENIOR	Std. Qual.	Sgls Upgrd Qual.	Sgls Upgrd Qual.	Sgls Upgrd Qual.	Dble Upgrd Qual.	Dble Upgrd Qual.	Dble Upgrd Qual.	Not Qual. (xxx)	Not Qual. (xxx)	Not Qual.	Not Qual.	Not Qual.	Not Qual.	Not Qual.
UNDER 22	Not Qual.	Std. Qual.	Std. Qual.	Std. Qual.	Sgls Upgrd Qual.	Sgls Upgrd Qual.	Sgls Upgrd Qual.	Not Qual.	Not Qual.	Not Qual.	Not Qual.	Not Qual.	Not Qual.	Not Qual.
JUNIOR	Not Qual.	Not Qual.	Not Qual.	Not Qual.	Std. Qual.	Std. Qual.	Std. Qual.	Sgls Upgrd Qual.	Sgls Upgrd Qual.	Sgls Upgrd Qual.	Not Qual.	Not Qual.	Not Qual.	Not Qual.
CADET	Not Qual.	Not Qual.	Not Qual.	Not Qual.	Not Qual.	Not Qual.	Not Qual.	Std. Qual.	Std. Qual.	Std. Qual.	Sgls Upgrd Qual.	Sgls Upgrd Qual.	Sgls Upgrd Qual.	Sgls Upgrd Qual.
MINIME	Not Qual.	Not Qual.	Not Qual.	Not Qual.	Not Qual.	Not Qual.	Not Qual.	Not Qual.	Not Qual.	Not Qual.	Std. Qual.	Std. Qual.	Std. Qual.	Std. Qual.

Horizontal Lines represent the Categories of Age and Vertical Lines represent the Age of Players (determined either by the Year of birth or the Age itself). The intersection of each Horizontal Line and Vertical Line indicates if the Player is qualified for the given Category of Age according to his/her Year of Birth and/or Age.

(xxx) Exception for Under 22 and Seniors Championships only: a team may have up to four (4) players at the age of fifteen (15) years and over, with the condition that the same team have in its Official Competition Roster a minimum of twelve (12) players at the age of seventeen (17) years and over. If a team submit an Official Competition Roster with listed nine (9) players only, all of them shall be at the age of seventeen (17) and over.

QUALIFICATION OF PLAYERS			
Qualification		Result	Notes
Std. Qual.	Standard Qualification	PLAYER QUALIFIED	The Age of the Player is within the Limits for this Category of Age
Sgple Upgrd Qual.	Single Upgrade Qualification	PLAYER QUALIFIED	Although of the immediate lower Category of Age, the Player is qualified according to article 14.07.02
Dble Upgrd Qual.	Double Upgrade Qualification	PLAYER QUALIFIED	Although of a two-levels lower Category of Age, the Player is qualified according to article 14.07.02
Not Qual.	Not Qualified	PLAYER NOT QUALIFIED	The Player is either too young or too old to be qualified in this Category of Age

14.08. A team with less than nine (9) players in Fastpitch, or ten (10) players, in Coed Slowpitch, at the moment of the ID control cannot participate in the Competition. The subscription fee will not be refunded.

15.01. A player who cannot present his passport or ID card to the ID control will not be allowed to participate in the Competition.

15.02. A player who has been excluded from playing by an Affiliated Federation may not participate in European Competitions. Affiliated Federations shall inform the ESF of such exclusions.

PLAYERS LICENCES

16.00. Only those players officially licensed by the ESF may participate as players in European Championships, Cups or Competitions organized by the ESF

16.01. After entry to a Championship or Cup Tournament the Federation or Club team shall submit to the ESF the Application Form for Licences.

16.02. The completed Application Form for Licences must state: The Name of the Federation or Club team and, for each player: his/her Surname, First Name, Date of Birth, Nationality, indication if the Player is or not a Pick-up Player, ESF Licence Number if already supplied
This Form provides for a maximum of thirty (30) names of participants.

16.03. The completed Application Form for Licences must be signed by the legal Representative of the appropriate Affiliated Federation and in the case of a participating Club it must be also signed by the Club's legal Representative. For players other than Pick-up Players, the Application Form for Licences, duly endorsed by the National Federation and Club, constitutes the Official Declaration and Affidavit that the Players are bona fide Members of the Club as contemplated in article 17.02.

16.04.01. The Federation or Club team shall send the Application Form for Licences, duly signed, to the ESF no later than forty-five (45) days before the start of the Competition. The late submission of an Application Form for Licences is subject to the assessment of a late-filing penalty, which amount is indicated in the Financial Appendix.

16.04.02. No Application Form for Licenses will be accepted later than thirty (30) days before the start of the Competition. A Team which has not submitted its Application Form for Licenses within the 30 days delay will be automatically excluded from the Competition.

16.04.04.01. The modification of an already submitted Application Form for Licences before the 45 days delay as contemplated in article 16.04.01 is always possible without any penalty.

16.04.04.02. The modification of an already submitted Application Form for Licences after the 45 days delay as contemplated in article 16.04.01 and before the limit date as contemplated in article 16.04.02 is considered as the submission of a late Application Form and is contingent to the same penalty and delays.

16.05.01. For a copy of each team's Player License List shall be communicated by the ESF License Administrator to every other team participating in the Competition no later than fifteen (15) days before the start of the Competition. The publication on the ESF Web Site will be considered as such communication. Protests relating to matters of player eligibility must be submitted to the Chair of the Technical Commission no later than seven (7) days before the start of the Competition.

16.06. The Federation or Club team shall present at the ID control in the tournament its Official Competition Roster and Passports and/or ID cards of all players listed in this roster.

16.07. The Official Competition Roster of players shall consist only of names of the persons who are already on the Application Form for Licences. All other persons shall be automatically banned from participation.

16.08. The Technical Committee may suspend a player for a certain period by withdrawing a Licence.

16.09. If requested by the Organizers, participating teams shall send them their expected final roster, together with a team photo, at the latest (30) thirty days before the official opening day of the Competition.

PLAYERS QUALIFICATION

17. 00. To take part in the European Cups all players must conform to articles 14.06, 17.01 and 17.02 as follows:

17. 01. Being entered by their Club on the corresponding Official Competition Roster.

17. 02. Being a bona fide Member of the Club they are entered by.

Note: the requirement of article 17.02 does not apply to pick-up Players as defined in article 14.06

17.03. A player can represent only one Club in European Cup Competition for a given year and hence can appear on only one Application Form for Licences from only one Club.

17.04. Deleted

17.05. In case of protest pursuant to article 16.05.01 the Technical Commission shall take a decision on the eligibility of the Player in question and make it public before the Technical Meeting. The decision of the Technical Commission shall be based on the information obtained from the plaintiff who put the protest and the National Federation and Club who guaranteed the eligibility of the Player.

17.06. However if during or after the Competition the information obtained by the Technical Committee pursuant to article 31.03.02 is proved to be incorrect, the Executive Council may impose sanctions.

OFFICIAL COMPETITION ROSTER

18.01. At the ID control meeting, teams participating in a Competition shall hand in a completed Official Competition Roster. This Roster may contain names for a maximum of seventeen (17) players in fastpitch, or eighteen (18) players in Coed slowpitch, who will be the only ones entitled to take part in the Competition. In addition this Roster may contain a maximum of eight (8) names of coaches, instructors and/or therapists in total.

18.02. Only players whose names have already been entered on the Application Form for Licences of the team, and who have validly been checked by the Technical Committee, as per articles 15, 16 and 17, can be entered on the Official Competition Roster.

18.03. Transferred as 16.05.01.

18.04. Only players and other team members entered on the Official Competition Roster are allowed to enter the Competition fields and dug-outs.

18.05. Only players entered on the Official Competition Roster are entitled to appear on the line-up forms for the games of the Competition. In case of dispute concerning the qualification of a player, the Official Competition Roster shall be the reference document.

CEREMONIAL

19.01. All Participating Teams shall be present at the Opening Ceremony. Only those teams receiving a medal (bronze, silver or gold) shall be present at the Closing Ceremony.

19.02. To be considered as "present", a team must be represented by a minimum of 9 (nine) members. Only players and other team members entered on the Official Competition Roster of a given team may represent said team at the Opening and Closing Ceremonies.

19.03. During the Opening and Closing Ceremonies, team members must wear team uniforms pursuant to article 22.01 or must be all dressed alike.

19.04. During the Opening and Closing Ceremonies, team members shall conduct themselves with the most appropriate manner. In particular, eating, drinking, unsportsmanlike or inadequate gestures, or excessive demonstrations are strictly prohibited.

19.05. Teams which do not abide by articles 19.01 to 19.04 will be subject to the penalties specified in the Financial Appendix, without prejudging of any disciplinary sanctions as decided by the Executive Council.

PLAYING FIELDS

20. The first base dug-out is for the visiting team and the third base dug-out is for the home team.

21. The double first base (safety base) is mandatory for all ESF Competitions.

TEAM UNIFORM

22.01. All players must be uniformed alike in a given team. Notwithstanding article 7.02.c of the ISF Technical and Procedural Code, players in European Competitions may wear either short or long trousers; however they must stay uniformed within a given team.

22.02. In the European Championships the National team players must have the name of their country, or an emblem depicting their national origin, on the front of the uniform.

22.03. Numbers must be shown on the back of the uniform and be minimum 15 cm. in height.

22.04. The name of one or more sponsors may appear on a team's uniform. However, then the looks of sponsors' name(s) and/or logo(s) must be the same and be on the same locations on the uniform.

23.01. Caps, visors and headbands are optional for female players and may be mixed, as long as the colour is the same for all headgear of the whole team.

23.02. Two teams shall not in any games wear the same or similar coloured uniforms.

Each team shall be required to have a contrast colour / dark colour shirt and a white / light colour shirt
The home team will wear a contrasting coloured / dark colour shirt and the visiting team will wear a white / light colour shirt.

CANDIDATES FOR ORGANIZING A COMPETITION

24.01.01. *Every candidature to host an European Competition shall be on a form prescribed by the Executive Council and shall be signed by the candidate and the Affiliated Federation. The form shall contain all relevant information required by the Executive Council, acting in its sole discretion, to enable an informed decision to be made. The candidature shall be submitted to the ESF Secretary General at least 90 days before the date of the Annual General Congress, which shall consider and act upon any nomination duly presented for consideration.*

24.01.02. *Every candidature to host an European Competition shall be presented together with: a) a payment of a bona fide deposit of 20 per cent of the guarantee sum specified for organizing this competition (see Financial Appendix); b) a duly filled Pre-Inspection Form which shall be requested to the ESF.*

24.01.03. *The performance of the competition host shall be guaranteed by the Affiliated Federation involved, which may include appropriate insurance to cover those contingencies notified to the Affiliated Federation by the Executive Council or the Technical Commission.*

24.01.04. *Every competition venue must conform to TR 09.01.*

24.01.05. *Every candidature for a European Championship must clearly propose a date (within the month of July, as per CR 01.04.01) and the exact location where this competition will take place. Every Candidature for a Cup Competition must give the exact location where this competition will take place.*

24.01.06. *A properly competed form with the correct fee shall constitute a Nomination for purposes of the Statutes and shall be considered as provided for in the Statutes and these Regulations.*

24.02.01. Should there be more than one candidate to host a European Competition, then the final choice shall be made during the Technical and Competitions Committee meeting prior to the General Congress.

24.02.02. *The following shall govern in the event of no nomination for a European Competition being made.*

24.02.02.01. *If no nomination to host a European Competition is received by the date specified in CR 24.01.01, nominations remain open until the start of the Technical and Competitions Committee meeting prior to the General Congress, at which time nominations will be received and considered at this meeting. Should there be no candidate to*

host a European Competition at the end of this meeting, the limit date to receive candidatures shall be extended until the last day of February of the given year.

24.02.02.02. Should there be no candidate to host a European Competition after the last day of February of the given year, the Competition shall be cancelled for the current year. Should there be more than one candidate to host a European Competition submitted by the last day of February of the given year, the final choice shall be made by the Executive Council.

24.03. Once it has been officially appointed, the host Federation or Club shall pay an additional 30 per cent of the guarantee sum specified for organizing this Competition within 10 days after the official announcement in the year. The balance of 50 per cent of this guarantee sum shall be paid at the latest forty (40) days before the start of the Competition.

The guarantee sum paid by the candidate Organizers not appointed will be refunded.

24.04. Candidatures to host European Competitions must conform to the requirements of the articles of the present Regulations and to the Technical Regulations.

24.05.01. Once it has been officially appointed, the host federation or Club shall send within one month to the participating teams, after control by the ESF Executive Council and Technical Commission, a list of at least three appropriate hotels in different price ranges/levels available for the accommodation of teams, to be referred to as "approved hotels".

24.05.02. Teams wishing to use accommodation not in this list shall receive prior approval of the organizer. In the absence of such approval, transportation of the teams between hotels and fields shall be under their sole responsibility.

24.05.03. If within one month after it has been officially appointed the Organizer has not sent the list of approved hotels, participating teams are free for their own accommodation and the Organizer remains responsible of their transportation between hotels and fields within a 25 km radius.

INSPECTION OF COMPETITION ORGANIZATION

25.01. The ESF, through its website, shall make available a Pre-Inspection Form for Organizers of European Competitions. The completed Pre-Inspection Form shall be returned to the ESF Secretary General with all necessary documents (as per CR art. 24.01), at least 90 days before the date of the Annual General Congress. The ESF Secretary General shall distribute the completed Pre-Inspection Form to the Members of the Executive Council, the Chairman of the Technical and Competitions Commission.

25.02.01. The Executive Council of the ESF shall appoint a representative hereafter referred to as "the Inspector" to inspect the fields and examine the total organization of each Competition prior to the start of the Competition.

25.02.02. The travel costs of the Inspector to the Organizers' country are under the responsibility of the ESF. The expenses for local transportation, board, accommodation and related costs of the Inspector are under the responsibility of the Organizers.

25.03. The Inspector shall send his Report to the Chairman of the Technical and Competitions Commission, who shall distribute it to the Members of the Executive Council and the Organizers.

25.04. If the Inspection reveals that the requirements, duties and obligations expected of the Organizers have not been met or carried out, the Organizers must correct these omissions before the opening of the Competition.

25.05. In case of serious and legitimate doubt, The Executive Council may decide to conduct a second Inspection to verify if the revealed omissions have been corrected. All the costs of this second inspection shall be under the responsibility of the Organizers.

25.06. Accommodation of the Inspector shall comply with the requirements for accommodation of Official as stipulated in the Technical Regulations.

ASSIGNMENTS AND APPOINTMENTS OF OFFICIALS

26. All assignments and appointments of Officials shall be approved by the Executive Council for every European Competition, as follows:

26.01. The Executive Council appoints one of its Members as Official Executive Delegate of the ESF.

26.01.01. In A Division Cup Competitions, the attendance of the appointed Executive Delegate for the entire duration of the competition or for only the last part of the Competition will be subject to the decision of the host Club.

26.01.02. In B Division and lower Divisions Cup Competitions the attendance of the appointed Executive Delegate for the entire duration of the competition, for only the last part of the competition, or for not attending at all will be subject to the decision of the host Club.

26.02.01. The Executive Council appoints the Chief Technical Commissioner and the Technical Commissioners upon proposal of the President Chairman of the Technical Commission.

26.02.02. Local Technical Commissioners are nominated by the Organizers. They must be able to communicate in English. Their appointment must be approved by the Chairman of the Technical Commission and confirmed by the Executive Council.

26.03. The Executive Council appoints the Umpires Commissioner and approves the assignment of Umpires upon proposal of the President of the Technical Commission on the recommendation of the Umpire-in-Chief.

26.04. Scorers are assigned by the Organizers. However the Executive Council may object to a scorer's assignment upon motivated advice of the President of the Technical Commission.

DUTIES OF OFFICIALS

27. The Officials assigned to European Competitions represent the ESF and shall act as such in all circumstances. They shall perform their duties in full neutrality, objectivity, and impartiality and with the adequate attitude and behaviour. In particular, Officials, this including Members of the Executive Council, of the Technical Committee and Umpires, shall not wear patent or visible signs or marks of nationality or of belonging to a Nation, a national Federation, or a Team.

27.01. The Official Executive Delegate shall be the Representative of the ESF for the entire duration of the Competition, and is vested of the authority on other ESF Officials and the Organizers to guarantee that the Competition is organized and conducted in accordance with the Objectives, Principles and Regulations of the ESF. The Official Executive Delegate chairs the protocolar ceremonies and assumes the promotional and relational responsibilities of the ESF towards the organizers and the local Authorities. The Official Executive Delegate acts as the appeal organ for cases subject to appeal during the Competition, and as a liaison with the Executive Council.

27.02. The Technical Committee is in charge of the technical aspect of the Competition. It is made of the following Officials, endowed with the following responsibilities:

27.02.01. The Chief Technical Commissioner is responsible for the coordination and the supervision of the Technical Committee of the Competition. The Chief Technical Commissioner shall be present for the entire duration of a European Competition. In particular, the Chief Technical Commissioner is in charge of the scheduling of the Competition, and of the respect by the Organizers of the organization requirements.

27.02.02. The Technical Commissioners act under the authority of the Chief Technical Commissioner. One Technical Commissioner shall be present at every game of a Competition. Technical Commissioners shall be either permanent members of the Technical Commission or Assistant Technical Commissioners appointed among local competent persons.

27.02.03. The Umpire Commissioner is responsible, under the supervision of the Chief Technical Commissioner, of the management, the assignment, the follow-up and evaluation of the Umpires during the Competition. The Umpire Commissioner is responsible of the technical training of the Umpires during the Competition in order to maintain and guarantee the required technical level of umpiring.

27.02.04. The Umpires assigned to a Competition must be present at the venue in time for a pre-tournament meeting as specified by the Technical Committee.

27.03. The Technical Committee shall be responsible for and enforce the technical aspects of the Competitions, and ensure that the Rules of Softball, the ESF Competitions and Technical Regulations are scrupulously respected. In particular, the Technical Committee shall:

27.03.01. check the identity and eligibility and qualification of the participating players;

27.03.02. check when necessary the respect of the legal requirements for participating players and teams;

27.03.03. check the conformity of the Competition's installations and facilities with the Rules of Softball, and the Competitions and Technical regulations;

27.03.04. take any sanctions to be imposed when a player or team member has been ejected from a game;

27.03.05. take any appropriate decision in case of protest;

27.03.06. control and verify the conformity and the availability of the statistics ;

27.03.07. propose to the Executive Council any penalty as stated in the ESF Regulations in case of violation or disrespect by the Organizer or by a team or by a team member of its obligations.

27.04. The Executive Council may, upon proposal of the Technical Commission, require that the Chief Technical Commissioner will arrive one day in advance at the venue of the Competition to confirm that the necessary actions required have been satisfactorily executed. The expenses for this additional day shall be under the responsibility of the Organizers.

ACCREDITATION OF MEDIA

28.01. Media accreditation

28.01.01. *A member of the media (print, electronic, photographic or broadcast) that wishes to be present at and cover or otherwise provide coverage of or for an ESF Competition is required to comply fully with the requirements in this CR. Media credentials belong to the ESF and may be revoked at any time for any reason. Any failure to observe these at any time may result in the suspension or revocation of media credentials for a specific event or the remainder of a season. The submission of a request for credentials on the Media Accreditation Request constitutes acceptance of the terms of this CR and any other conditions or restrictions imposed by the ESF.*

28.01.02. *All accreditation requests must be fully completed and submitted to the ESF not later than 20 complete business days (a day excluding a Saturday, Sunday or public holiday) prior to the first day of the ESF Competition for which accreditation is sought. No other requests shall be processed.*

28.02. *A person to whom ESF media accreditation is given is referred to as an "Accredited Media Person" or "AMP". Once awarded, media accreditation is personal to that AMP and non-transferable.*

28.03. *An AMP assumes all risks incidental to the performance of his/her service or incidental to the game that he/she covers. An AMP must not endanger himself/herself or others by engaging in negligent, reckless, prohibited or irresponsible behavior. An AMP waives any and all complaints, claims or other charges against the ESF, the Executive Council, ESF Competition organizers and players, and such entities shall have no liability of any kind as regard an AMP covering a game. Damage to or loss of an AMP's equipment is personal to the AMP. Every AMP must have current, suitable and appropriate insurance as regards his/her activities at an ESF Competition and shall produce evidence of same upon request.*

28.04. *Media accreditation passes must be displayed prominently at all times. While within the event venue, an AMP shall be subject to and comply with the directions and/or supervision of the tournament organizers, the Technical Committee and any Executive Council representative.*

28.05. *Any information imparted to an AMP that is in any way restricted, such starting line ups provided in advance of a game, field or player conditions, shall not, without the prior written consent of the Technical Committee, be shared with any other person.*

28.06. Photographers and camera operators

28.06.01. *Photographers' accreditations will only be issued to professional sports photographers in possession of an international media/press card. The ESF reserves the right to require freelancers to establish that they are working by order of an agency, editorial office or the ESF directly. Possession of an international media/press card is no guarantee that media accreditation will be issued.*

28.06.02. *AMPs shall be required to observe the following:*

28.06.02.01. *at no time prior to, during, or after a game enter the field of play or the players' area (including dressing rooms for players, coaches, and referees);*

28.06.02.02. *to stay within the areas designated by the ESF and tournament organizers and ensure that technical equipment is positioned or stored such that it does not pose any hazard to third parties;*

28.06.02.03. *no AMP shall, directly or through third parties, during a game or until two hours after the game, provide any pictures (stills or sequences of stills) for publication and further use on mobile phones (in particular via MMS) and via DVB-H and DMB;*

28.06.02.04. *AMPs shall ensure that pictures are used for editorial and journalistic reporting purposes only. Any use of pictures for commercial and/or advertising purposes requires the prior written approval by the ESF and, if applicable, other rights holders.*

28.07. *The ESF and its organizers do not accept any liability for damage to AMP's property or personal goods. AMPs must be considerate of all visitors when gaining the best photographic position, not obstruct the view of on field photographer or cameraman. AMPs must not attempt to sell photographs in any form to the connections of any ESF Tournament. Photograph and videotaping is permitted only in special proven areas.*

28.08. Personal attire shall be suitable, appropriate and in conformance to the dress code set out by the Organizers and the ESF.

28.09. Termination of media accreditation

Non-compliance with the terms and conditions described in the grant of media accreditation or this CR may result in the immediate suspension or withdrawal of accreditation, and may also lead to future accreditation requests being refused.

29. deleted

SCOREKEEPING AND STATISTICS

30.01. The host Federation or Club shall appoint at least one official scorekeeper for each game. Scorekeepers shall be experienced in softball and qualified for their function. The List of assigned scorers shall be sent to the Technical Commission at least one month before the beginning of the Competition.

During the game, the official scorekeeper shall be accommodated in a "Scoring House" near the field as mentioned in the Technical Regulations.

Immediately after each game, the official scoring sheet shall be given to the Technical Committee.

30.02. From 2011, only electronic scoring system shall be used. Paper scoring systems (on specific softball scoring sheets) shall remain as backup support for electronic scoring system. The required electronic scoring system is 'The Automated Scorebook', 'TAS' (www.statcrew.com).

30.03. After each day of a European Competition the results of the games shall be published by the Chief Technical Commissioner on the ESF website in accordance with the Technical Regulations.

30.04. After completion of a European Competition, the detailed results and statistics shall be communicated to the ESF Secretary General within fourteen (14) days in accordance with the Technical Regulations.

PROTESTS

31.00. Protests shall be made according to the ISF Rules.

31.01. Protests regarding the interpretation or application of the Rules of Softball shall be notified to the Plate Umpire. The Plate Umpire shall then notify the Technical Committee. Protests regarding the eligibility of Players shall be notified directly to the Technical Committee.

31.02. When notified of a protest, the Technical Committee may decide to suspend the game under protest until it makes its decision. In such case the Technical Committee may require that the Official written protest be lodged in less time than the delay stipulated in article 31.03.

31.03. Except if the Technical Committee has suspended the game and required a specific delay as per article 31.02, the Official written protest shall be lodged within fifteen minutes after the end of the game. Official protests shall be written in the English. Upon reception of an Official written protest the Technical Committee shall meet immediately and make its decision without delay.

31.03.01. The decisions of the Technical Committee on protests regarding the interpretation or application of the Rules of Softball are not be subject to appeal.

31.03.02. The decisions of the Technical Committee on protests regarding the eligibility of Players may be subject to appeal in case of supervening of new elements as stipulated in article 17.06.

31.04. In case of illegal protest or wrong use of protest the Technical Committee may propose to the Executive Council a financial penalty against the offending team.

31.05. Protests may also be made by Officials, Members of the Executive Council of the ESF, Members of the Technical Committee of the ESF and/or Umpires.

OBLIGATIONS AND DUTIES OF ORGANIZERS

33.00. Notwithstanding other requirements as stated in present Regulations and in the Technical Regulations, the host Federation or Club shall pay the following expenses:

33.01. Accommodation, board and local transportation for the Officials, the Members of the Executive Council of the ESF, the Members of the Technical Committee and the Umpires, in accordance with the requirements of the Technical

Regulations. Provisions shall be made for this from the day before the start of the Competition up to and including the day after the end of the Competition.

Similar provisions shall be made for an additional day for the Chief Technical Commissioner pursuant to article 27.04., when necessary.

33.02. Game balls for the Competition, in accordance with the ISF Rules.

NOTE: Thanks to sponsoring, game balls may be provided free of charge until otherwise stated. If game balls are sponsored, then the Organizers must provide a place on the fields for this sponsor's publicity. If requested by the sponsor, Organizers must provide a place near the fields for this sponsor's sales stand.

33.03. General expenses for awarding the Competitions, as mentioned in article 39.03.

The medals for the first, second and third places (gold, silver and bronze) of the European Competitions are provided and settled by the ESF.

33.04. Local transportation for the teams between the hotel(s) and the fields pursuant to article 24.05.

33.05. Presence of qualified first aiders at the Competition sites.

33.06. *Flags of all participating nations shall be displayed at the main venue.*

33.07. *National Anthems of the teams at European Championships shall be played prior to the start of each game.*

34.01. The Organizers shall arrange for insurance to cover their responsibilities and liabilities within the framework of the Organization of the Competition.

34.02. The Organizers shall make sure that there is no reference, in the Competition's documents, programs, accreditation system, to the nationality or country of belonging of the Officials, this including the Members of the Executive Council, the Technical Committee and the Umpires.

35. When the requirements, duties and obligations of the Organizers are not met, even in part, the Executive Council of the ESF may decide upon a proposal of the Technical Committee not to refund part or the whole of the guarantee sum referred to in article 24.

OBLIGATIONS AND DUTIES OF PARTICIPATING TEAMS

36.01. All teams, except the team of the host Federation, shall be present at the place established for the Competition no less than twelve hours before the first scheduled game.

At least one representative of each team shall be present at the Technical Meeting.

36.02. The teams are responsible for their travelling expenses to and from the Competition venue at their arrival and departure, board and lodging.

36.03. Each *Affiliated Federation* is responsible for the travelling expenses *to and from any ESF Competition for as many Umpires as the teams this Affiliated Federation enters in the current year.*

37. When in the frame of the Competition the requirements and obligations of a team are not met, even in part, or if any member of a team does not behave according to generally accepted Morals and Ethics and in a Sportive Spirit, the Executive Council of the ESF may decide preferably upon a proposal of the Technical Committee to impose penalties, the amount of which will be determined by the Executive Council.

38.01. Consistent with the declarations on the Competition Entry Form, the participating teams shall arrange for insurance cover for all their members according to their national legal requirements relating to participation to sport competition, including civil responsibility, personal injuries, medical treatment and as provided for by CF 40.05, specific protections for underage players.

38.02. The First Aid Assistance supplied by the Organizers shall cover only the on-the-field emergencies and not further medical treatment.

38.03. The ESF is not responsible for any material or physical damage occurring within the framework of the Competition.

AWARDS

39.01.01. The European Challenge Trophies for European Competitions shall be presented by the President of the ESF,

if present, or the Official Executive Delegate to the winning team after each Competition. The winner may keep the Trophy until the next Competition. They shall engrave their name and the year of victory on the Trophy.

39.01.02. Each Title Bearer holding a European Challenge Trophy shall be responsible to bring it to the Congress of the year of the next Competition.

39.01.03. Each Organizer, under supervision of its National Federation, shall be responsible for the reception of the corresponding European Challenge Trophy in the Congress and of its presence and availability at the venue of the Competition.

39.02. All personal awards excluding the MVP award shall be determined before the Page Playoffs begin by a Committee presided over by the Chief Technical Commissioner at the Competition.

39.03.00. The host Federation or Club is responsible for the following awards:

39.03.01. Trophy for top three teams, apart from the European Challenge Trophy for the winning team (CR 39.01.01).

39.03.02. Deleted

39.03.03. Personal awards:

39.03.03.01. Award for the Best Pitcher, on the basis of the "Earned Runs Average", with a minimum of 1.6 "Innings Pitched" per game in Youth categories (Minime, Cadet, Junior) and a minimum of 2.1 "Innings Pitched" per game in Senior category.

39.03.03.02. Award for the Best Batter, on the basis of the "Batting Average", with a minimum of 2.0 "Total Appearances" per game in Youth categories (Minime, Cadet, Junior) and a minimum of 2.5 "Total Appearances" per game in Senior category.

39.03.03.03. Award for the Most Valuable Player.

39.03.04. If desired by the host Federation or Club, it may also give personal awards for:

39.03.04.01. The Best Infielder.

39.03.04.02. The Best Outfielder.

39.03.05. If the host Federation or Club wishes to present additional awards, it may do so only after having received formal permission from the Executive Council.

39.03.06. The host Federation or Club must make sure that the engravings of all awards provided by them are written at least in English and include the ESF name or logo and the official name and date of the Competition.

SPECIFIC REGULATIONS FOR YOUTH COMPETITIONS

40.01. GAMEBALLS

40.01.01. In Cadette Competition the 12 inches gameball shall be in use.

40.01.02. In Minime Competition the 11 inches gameball shall be in use.

40.02. PITCHING DISTANCE

40.02.01. In Cadette Competition the pitching distance shall be 12,19 m.

40.02.02. In Minime Competition the pitching distance shall be 10,67 m.

40.03. DURATION OF GAMES

40.03.01. In Cadette Competition games shall be played in SIX (6) innings and shall not exceed TWO (2) hours.

40.03.02. In Minime Competition games shall be played in FIVE (5) innings and shall not exceed TWO (2) hours.

40.03.03. If, before one hour and forty-five minutes of play, the said number of innings is complete (which includes the home team being ahead at the beginning of, or drawing ahead during, the bottom of the last inning), with a result other than a draw, the game shall be regulation.

40.03.04. If the said number of innings is not complete at one hour and forty-five minutes, the Plate umpire shall call 'No New Inning'. The inning in progress will then be played to completion or until the home team draws ahead. If the inning in progress ends in a draw, extra inning(s) will be played until a result other than a draw is obtained.

40.03.05. All extra innings will be played under 'tie-break' rules.

40.03.06. The time limit of two hours does not apply for the Page System Games (Semi-Finals and Finals)

40.04. PROVISIONS FOR PITCHERS

40.04.01. There is no specific provision for Pitchers in Cadette Competition.

40.04.02. In Minime Competition Pitchers are subject to the following limitations: No more than FOUR (4) innings in a Game; No more than SIX (6) innings in a day; No more than NINE (9) innings in TWO (2) consecutive days. The sanction for not respecting these limitations is an automatic game loss (5-0) for the offending Team. The Official Scorekeepers will be in charge of recording and controlling the innings accounted to each Pitcher under the responsibility of the Technical Committee. An inning is accounted to a Pitcher as soon as the Player appears in an inning in the Pitcher's position.

40.05. PROTECTION OF UNDERAGE PLAYERS

40.05.01. The duly signed and dated Competition Entry Form for each Team with underage players shall have the following declaration:

- Each Player is in compliance with ESF Competitions Regulations regarding age and nationality.
- Each Player has received full, unconditional written authorisation by his/her Parent(s) or Legal Representative or Guardian to participate to the Competition. The Team's Management has been invested with complete legal authority to handle all matters arising concerning each Player during the Competition.
- Each Player conforms to the Rules of our National Federation with respect to qualification and participation in this Competition.
- Each Player is medically able to participate in this Competition. Any condition has been duly notified to the Team's Management which shall keep the ESF Chief Technical Commissioner fully informed of any such matter.
- We assume full and complete responsibility for any matter arising directly or indirectly from any misrepresentation of any fact in this Affidavit and agree to hold the ESF, the ESF Chief Technical Commissioner and any other party involved with the Competition harmless in connection with any matter arising from this Affidavit.

40.05.02. The ESF is not responsible for incorrect or false declarations.

SPECIFIC REGULATIONS FOR SLOWPITCH COED COMPETITIONS

41.01. PLAYERS

The number of Players is ten (10): Same as Fastpitch plus an extra outfielder. The ten (10) Players must consist of five (5) males and five (5) females; two (2) males and two (2) females in both the infield and outfield, and one (1) male and one (1) female as pitcher and catcher.

41.02. BATTING ORDER

The Batting order shall alternate male and female batters, but can start with either gender.

41.03. COMPETITION SYSTEM

41.03.01.

Four teams: triple round robin.

Teams ranked 1-4 play the Page System Playoff.

Minimum/Maximum Games per Team: 10/12

Round Robin Games: 18

Total Games: 22

41.03.02.

Five teams: triple round robin.

Teams ranked 1-4 play the Page System Playoff.

Team ranked 5 will be fifth in the competition.

Minimum/Maximum Games per Team: 12/15

Round Robin Games: 30

Total Games: 34

41.03.03.

Six teams: double round robin.

Teams ranked 1-4 play the Page System Playoff.

Teams ranked 5 and 6 play against each other to determine places 5 and 6.

Minimum/Maximum Games per Team: 11/13

Round Robin Games: 30

Total Games: 35

41.03.04.

Seven teams: double round robin.

Teams ranked 1-4 play the Page System Playoff.

Teams ranked 5-7 play a single round robin to determine places 5, 6 and 7.

Minimum/Maximum Games per Team: 13/15

Round Robin Games: 42

Total Games: 49

41.03.05.

Eight teams: single round robin.

Teams ranked 1-4 play the Page System Playoff.

Teams ranked 5-8 play a Page System to determine places 5, 6, 7 and 8.

Minimum/Maximum Games per Team: 8/10

Round Robin Games: 28

Total Games: 36

41.03.06.

Nine teams: single round robin.

Teams ranked 1-4 play the Page System Playoff.

Team ranked 9 will be ninth in the competition.

Teams ranked 5-8 play a Page System to determine places 5, 6, 7 and 8.

Minimum/Maximum Games per Team: 8/11

Round Robin Games: 36

Total Games: 44

41.03.07.

Ten teams: single round robin.

Teams ranked 1-4 play the Page System Playoff.

Teams ranked 5-6 play each other to determine places 5 and 6.

Teams ranked 7-8 play each other to determine places 7 and 8.

Teams ranked 9-10 play each other to determine places 9 and 10.

Minimum/Maximum Games per Team: 10/12

Round Robin Games: 45

Total Games: 52

41.03.08.

Eleven teams: two groups – one of five teams “a” and one of 6 teams “b”.

Each group plays a single round robin.

Teams ranked 1, 2 and 3 in both groups play a single round robin “c” in which the games between these teams in the first round “a” and “b” will also be considered as played games for this round robin “c”.

Teams ranked 4, 5 and 6 of both groups play a single round robin “d” in which the games between these teams in the first round “a” and “b” will also be considered as played games for this round robin “d”.

Teams ranked 1-4 in round robin “c” then play the Page System Playoff.

Teams ranked 5 and 6 in round robin “c” play each other to determine places 5 and 6.

Teams ranked 1-4 in round robin “d” then play a Page System Playoff to determine places 7, 8, 9 and 10.

The team placed fifth in round robin “d” will be placed 11th.

Minimum/Maximum Games per Team: 7/11

Round Robin Games: 40

Total Games: 49

41.03.09.

Twelve teams: two groups “a” and “b”, both of six teams.

Each group plays a single round robin.

Then teams ranked 1 and 2 of both groups play a single round robin “c” in which the games between these teams in the first round robins “a” and “b” will also be considered as played games for this round robin “c”.

Teams ranked 3 and 4 in groups “a” and “b” play a single round robin “d” in which the games between these teams of the first round robins “a” and “b” will also be considered as played games for this round robin “d”.

Teams ranked 5 and 6 in groups “a” and “b” play a single round robin “e” in which the games between these teams of the first round robins “a” and “b” will also be considered as played games for this round robin “d”.

Teams ranked 1-4 in round robin “c” then play the Page System Playoff.

Teams ranked 1-4 in round robin “d” play a Page System Playoff to determine Places 5, 6, 7 and 8.

Teams ranked 1-4 in round robin “e” play a Page System Playoff to determine Places 9, 10, 11 and 12.

Minimum/Maximum Games per Team: 8/10

Round Robin Games: 39

Total Games: 51

41.04. Field, Schedule and Competition Requirements

All ESF slowpitch co-ed competitions shall be conducted according to the following regulations:

41.04.01. Play in ESF slowpitch co-ed competitions shall begin no earlier than Tuesday of the competition week and can, at the discretion of the Technical Commission, begin on Wednesday or - in the case of a four-teams competition with two available competition fields only - on Thursday.

NOTE: The starting date will be based upon the number of entered teams.

41.04.02. Games will be scheduled at intervals of one hour and fifty minutes.

41.04.03. Any competition that consists of more than four entries will require two competition fields. The assumption is that a maximum of 6 games per field per day can be played or 12 games per day in total, assuming no disruption by weather or other circumstances. If Saturday is reserved for Page Playoff and other placing games, then the maximum number of round robin games that can be played is as follows:

- In a competition beginning on Thursday: 24
- In a competition beginning on Wednesday: " 36
- In a competition beginning on Tuesday: 48

41.04.04. The minimum number of games that a team can be scheduled to play on one full competition day (not shortened by weather or other circumstances and apart from the final day of competition) is two. The maximum number of games that a team can be scheduled to play on one full competition day is four.

41.04.05. The minimum outfield fence distance from home plate (unless special compensation is granted by the Technical Commission) will be 275 feet (83.82 metres).

41.04.06. All ESF slowpitch co-ed competitions will be conducted with 11-inch ball when females are batting and 12-inch ball when males are batting.

MASSIMO ROMEO YOUTH TROPHY

[42. TO BE RELEASED]