



Office of Transport Safety Investigations

BUS SAFETY INVESTIGATION REPORT

FATAL COACH ACCIDENT

BARRENGARRY NATURE RESERVE

14 MAY 2010



BUS SAFETY INVESTIGATION REPORT

FATAL COACH ACCIDENT

BARRENGARRY NATURE RESERVE

14 MAY 2010

Released under the provisions of
Section 45C (2) of the *Transport Administration Act 1988* and
Section 46BA (2) of the *Passenger Transport Act 1990*

Investigation Reference: 04483

Published by: The Office of Transport Safety Investigations
Postal address: PO Box A2616, Sydney South, NSW 1235
Office location: Level 17, 201 Elizabeth Street, Sydney NSW 2000
Telephone: 02 9322 9200
Accident and incident notification: 1800 677 766
Facsimile: 02 9322 9299
E-mail: info@otsi.nsw.gov.au
Internet: www.otsi.nsw.gov.au

This Report is Copyright. In the interests of enhancing the value of the information contained in this Report, its contents may be copied, downloaded, displayed, printed, reproduced and distributed, but only in unaltered form (and retaining this notice). However, copyright in material contained in this Report which has been obtained by the Office of Transport Safety Investigations from other agencies, private individuals or organisations, belongs to those agencies, individuals or organisations. Where use of their material is sought, a direct approach will need to be made to the owning agencies, individuals or organisations.

Subject to the provisions of the *Copyright Act 1968*, no other use may be made of the material in this Report unless permission of the Office of Transport Safety Investigations has been obtained.

THE OFFICE OF TRANSPORT SAFETY INVESTIGATIONS

The Office of Transport Safety Investigations (OTSI) is an independent NSW agency whose purpose is to improve transport safety through the investigation of accidents and incidents in the rail, bus and ferry industries. OTSI investigations are independent of regulatory, operator or other external entities.

Established on 1 January 2004 by the Transport Administration Act 1988, and confirmed by amending legislation as an independent statutory office on 1 July 2005, OTSI is responsible for determining the causes and contributing factors of accidents and to make recommendations for the implementation of remedial safety action to prevent recurrence. Importantly, however, OTSI does not confine itself to the consideration of just those matters that caused or contributed to a particular accident; it also seeks to identify any transport safety matters which, if left unaddressed, might contribute to other accidents.

OTSI's investigations are conducted under powers conferred by the Rail Safety Act 2008 and the Passenger Transport Act 1990. OTSI investigators normally seek to obtain information cooperatively when conducting an accident investigation. However, where it is necessary to do so, OTSI investigators may exercise statutory powers to interview persons, enter premises and examine and retain physical and documentary evidence.

It is not within OTSI's jurisdiction, nor an object of its investigations, to apportion blame or determine liability. At all times, OTSI's investigation reports strive to reflect a "Just Culture" approach to the investigative process by balancing the presentation of potentially judgemental material in a manner that properly explains what happened, and why, in a fair and unbiased manner.

Once OTSI has completed an investigation, its report is provided to the NSW Minister for Transport for tabling in Parliament. The Minister is required to table the report in both Houses of the NSW Parliament within seven days of receiving it. Following tabling, the report is published on OTSI's website at www.otsi.nsw.gov.au.

OTSI cannot compel any party to implement its recommendations and its investigative responsibilities do not extend to overseeing the implementation of recommendations it makes in its investigation reports. However, OTSI takes a close interest in the extent to which its recommendations have been accepted and acted upon. In addition, a mechanism exists through which OTSI is provided with formal advice by the Independent Transport Safety Regulator (ITSR) in relation to the status of actions taken by those parties to whom its recommendations are directed.

TABLE OF CONTENTS

TABLE OF FIGURES	ii
TABLE OF PHOTOGRAPHS	ii
ABBREVIATIONS	iii
ACKNOWLEDGEMENTS	iii
EXECUTIVE SUMMARY	iv
PART 1 CIRCUMSTANCES OF THE ACCIDENT	1
Accident Synopsis	1
Location	1
Before the Accident	3
The Accident	3
Emergency Response	4
Conditions	5
The Road	5
Signage	6
Possible Escape Route	9
G &S Mini Bus Pty Ltd	9
The Driver	10
Other Drivers of Coach TV 3574	10
The Coach	13
Allison MTB647 Transmission	14
Retarder	15
Brakes	17
Previous Defects	18
Mechanical Repairers / Maintenance	18
G&S Mini Bus Pty Ltd Workshop	18
Heavy Vehicle Repairer	20
Heavy Vehicle Authorised Inspection Station	21
OTSI/Police/RTA Inspection	21
NSW Bus Operator Accreditation Annual Self Assessment Report	26
Other Safety Issues	27
Motor Mechanic Qualifications	27
Data Recording Devices	27
Age of Fleet	28
Status of G&S Mini Bus	29
PART 2 FINDINGS	30
Causation	30
Contributory Factors	30
Other Safety Matters	31
PART 3 RECOMMENDATIONS	32
PART 4 APPENDIX	33
Appendix 1: Sources and Submissions	33

TABLE OF FIGURES

Figure 1: Accident location	2
Figure 2: Road gradient approaching crash site	6
Figure 3: Gradient classification diagram from AS1742.2 - 2009	7
Figure 4: Long Steep Descent sign	8
Figure 5: Sign requiring use of low gear	8
Figure 6: Schematic of coach chassis	14
Figure 7: Coach body and seating arrangement	14
Figure 8: Rear brake assembly	17

TABLE OF PHOTOGRAPHS

Photograph 1: Aerial view of accident site	2
Photograph 2: The coach's pathway prior to the accident site	4
Photograph 3: Position of range selector	5
Photograph 4: Possible escape route	9
Photograph 5: Retarder switch disconnected	15
Photograph 6: Retarder disconnected	16
Photograph 7: Coach being placed on RTA VIT	22
Photograph 8: View of inspection hole of rear brakes in the applied position	23
Photograph 9: Rear brake lining disintegration and exposed rivets	24
Photograph 10: The S cam clearly over stroked	25
Photograph 11: Condition of brake slack adjuster	26

ABBREVIATIONS

ABS	Anti-Lock Braking System
ASAR	(BOAS) Annual Self Assessment Report
BOAS	Bus Operator Accreditation Scheme
DIP	Directly Involved Party
DoT	Department of Transport (formally known as Transport NSW (TNSW), NSW Department of Transport and Infrastructure (NSWTI) and Ministry of Transport (MoT))
GVM	Gross Vehicle Mass
HVAIS	Heavy Vehicle Authorised Inspection Station
HVIS	Heavy Vehicle Inspection Scheme
ITSR	Independent Transport Safety Regulator
RTA	Roads and Traffic Authority of NSW
SMS	Safety Management System
TNSW	Transport NSW
VIT	Vehicle Inspection Trailer

ACKNOWLEDGEMENTS

OTSI wishes to acknowledge the assistance of Daltrans Inc in providing technical information on the Allison transmission and Bus Sales Online in supplying information on the coach involved in the accident.

EXECUTIVE SUMMARY

At approximately 7:15pm on 14 May 2010, a coach on charter from G&S Mini Bus Pty Ltd crashed through the guardrail on a tight curve on Moss Vale Road in the Barrengarry Nature Reserve, then continued through dense bush down a steep embankment, finally coming to rest in an upright position some 40 metres from the road.

The driver of the coach suffered fatal injuries as a result of the accident and 27 of the 28 passengers were injured, with the condition of three initially classified as critical. The coach had been chartered by the Polish-Australian Welfare Association, Ashfield, on behalf of the group of volunteer carers for the sick and disabled, to attend an activity in Kangaroo Valley.

The investigation found that the rear brakes of the bus were ineffective due to inadequate maintenance, and that a transmission output retarder intended to reduce the demand on the brakes was disconnected. As a consequence, the front brakes, which were in good condition, were unable to control the speed of the bus on the steep downhill section of road and also became ineffective due to brake fade.

The investigation also found that neither of the two monitoring devices fitted to the bus was operational and, therefore, there was no record of the movement and operation of the bus up to the time of the accident.

As the driver was the sole director/designated manager of G&S Mini Bus, Transport NSW was obliged to cancel its accreditation, so no recommendations are made in relation to the Company. However, it is recommended that the NSW Roads and Traffic Authority and the Department of Transport review opportunities to exchange information on buses that are defected as part of the twice yearly HVIS inspections, with a view to providing information to target compliance activity.

In relation to the carriageway in the precincts of the Barrengarry Nature Reserve, it is recommended that the Roads and Traffic Authority reviews the signage on Moss Vale Road between Fitzroy Falls and Barrengarry and also examines the feasibility of installing an arrester area in the vicinity of the accident site.

PART 1 CIRCUMSTANCES OF THE ACCIDENT

Accident Synopsis

- 1.1 At approximately 7:15pm on Friday 14 May 2010, a coach on charter from G&S Mini Bus Pty Ltd (G&S Mini Bus) crashed through the guardrail on a tight curve on Moss Vale Road in the Barrengarry Nature Reserve, approximately 10km South East of Fitzroy Falls (see *Figure 1*). It then continued on through dense bush down a steep embankment, finally coming to rest in an upright position some 40m from the road.
- 1.2 The driver of the coach suffered fatal injuries as a result of the accident and 27 of the 28 passengers were injured, with the condition of three initially classified as critical.
- 1.3 The coach had been chartered by the Polish-Australian Welfare Association, Ashfield, on behalf of a group of 28 volunteer carers for the sick and disabled, to attend an activity in the Kangaroo Valley.

Location

- 1.4 Main Road 79 is known as Nowra Road as it passes through Fitzroy Falls, and then becomes Moss Vale Road as it heads South East towards Kangaroo Valley. It is a two-way sealed road linking the Southern Highlands with the coast, and is classified by the NSW Roads and Traffic Authority (RTA) as a Main Road. The accident site is in an area surrounded by dense bushland within the Barrengarry Nature Reserve. The area is mountainous and there are long steep descending gradients in several locations throughout the district.
- 1.5 Approximately 4km to the South side of Fitzroy Falls there is a long descending gradient for approximately 7km. The accident occurred towards the downhill end of this long gradient on the second last hairpin bend (see *Photograph 1*).



Figure 1: Accident location



Photograph 1: Aerial view of accident site

Before the Accident

- 1.6 The driver left the Company's Bringelly depot at 3:30pm in order to fuel and prepare the coach for the trip. He arrived outside the White Eagle Club at Cabramatta at approximately 4.45pm in order to pick up the group from the Polish Australian Welfare Association. The coach was chartered to take the group to the Kangaroo Valley Bush Retreat in Kangaroo Valley and then return 'empty' to the Bringelly depot.
- 1.7 The tour group left at approximately 5.15pm making their way onto the M5 freeway. They travelled in a Southerly direction towards Mittagong taking the Mittagong exit, travelling through the townships of Mittagong and Bowral before passing through Fitzroy Falls at approximately 7pm.

The Accident

- 1.8 Approximately 4km after the township of Fitzroy Falls the road begins to descend with a steep winding gradient. As the coach commenced the descent, witnesses reported that there appeared to be no signs of the driver having any problems with the vehicle. The coach travelled for approximately 5km down the steep descending grade before passengers began to notice that the vehicle was swaying and moving about in an uncomfortable fashion. Several people called to the driver to slow down while at the same time a strong acrid smell was becoming evident inside the coach. One of the passengers, a retired police officer, stated afterwards that the smell was that of burning brakes. As the coach began to gain momentum, more people began to call to the driver to slow down.
- 1.9 Marks found on the roadway and on the left-hand verge indicate that the driver had tried to negotiate a sharp left hand curve, signposted with an advisory speed of 25km/h. However, as illustrated in *Photograph 2*, the bus continued across the road, crashing through the guard rail and over the embankment, finally coming to rest in an upright position some 40m from the road. As the bus crashed down the embankment, the driver was thrown from the vehicle and sustained fatal injuries.



Photograph 2: The coach's pathway prior to the accident site

- 1.10 At the crash scene, the gear selector in the bus was found to be in the 2nd range position as shown in *Photograph 3*, and the front brake drums were extremely hot and discoloured. When the bus was winched back onto the roadway, the rear wheels were observed to be rotating freely, indicating that the spring brakes were ineffective.

Emergency Response

- 1.11 Ambulance Services received a number of emergency calls via the 000 phone number from 7.21pm onwards, stating that a coach had been involved in an accident. The first Ambulance crew arrived at the site at 7.49pm. Ambulance and emergency crews stated that on their arrival there were already approximately 12 people from the coach at the roadside, having made their way up the embankment. Emergency crews immediately conducted triage to determine the most seriously injured passengers, with the driver of the coach being classified deceased at the scene. Conditions were difficult for emergency services due to the darkness and the density of the bushland.

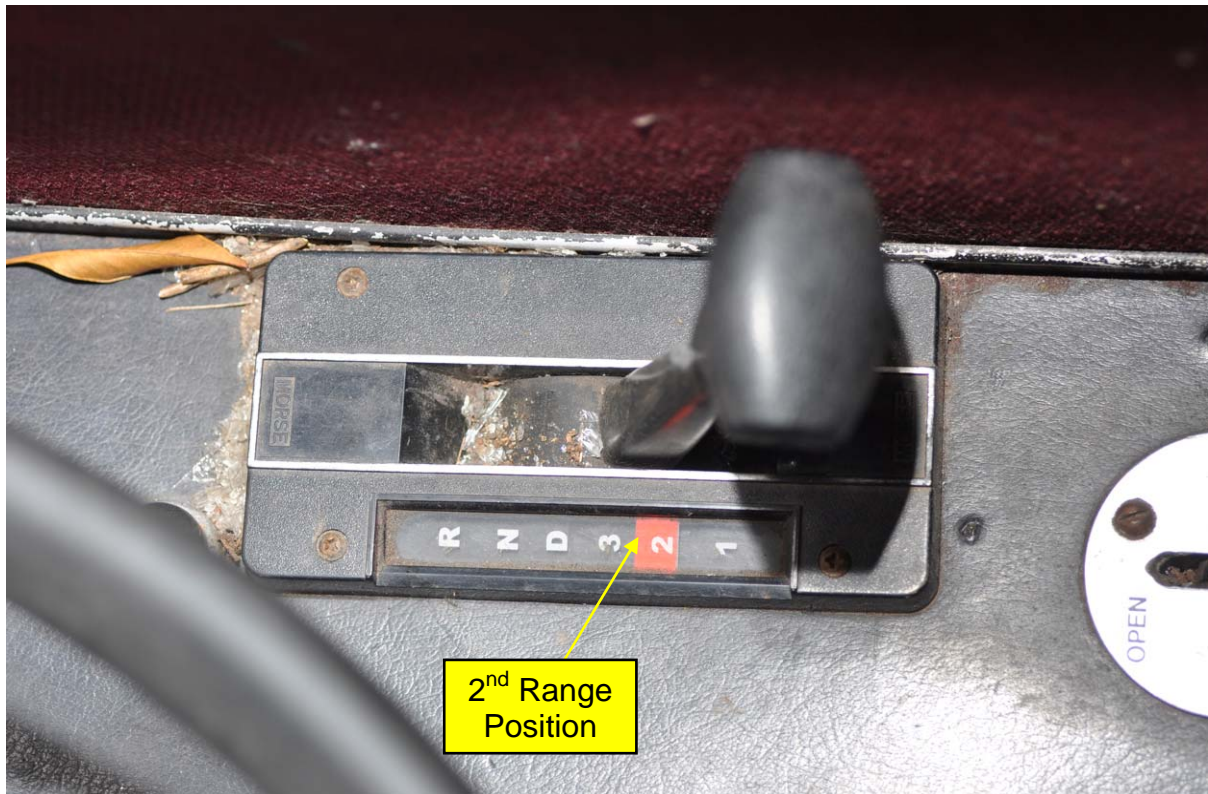

Photograph 3: Position of range selector

- 1.12 The rescue operation was hampered by the extent of the damage to the front of the coach so emergency crews cut through the left side of the vehicle towards the rear in order to assist the seriously injured.

Conditions

- 1.13 The weather conditions at the time of the accident were reported to be fine and dry. There had been no rainfall in the area for several days and the wind at Nowra at 3pm that afternoon had been reported as 20km/h from the SSE. At the time of the accident, it was extremely dark as there was no street lighting and sunset had occurred at 5.05pm and moonset at 4.54pm.

The Road

- 1.14 The road between Fitzroy Falls and Kangaroo Valley is a two-way, winding roadway with sharp curves and steep descents. OTSI obtained road mapping information from the RTA, providing gradient measurements every 10m for a distance of 5.8km leading up to the point of the accident. *Figure 2* is a graphical representation of this data simplified by using 100m intervals.

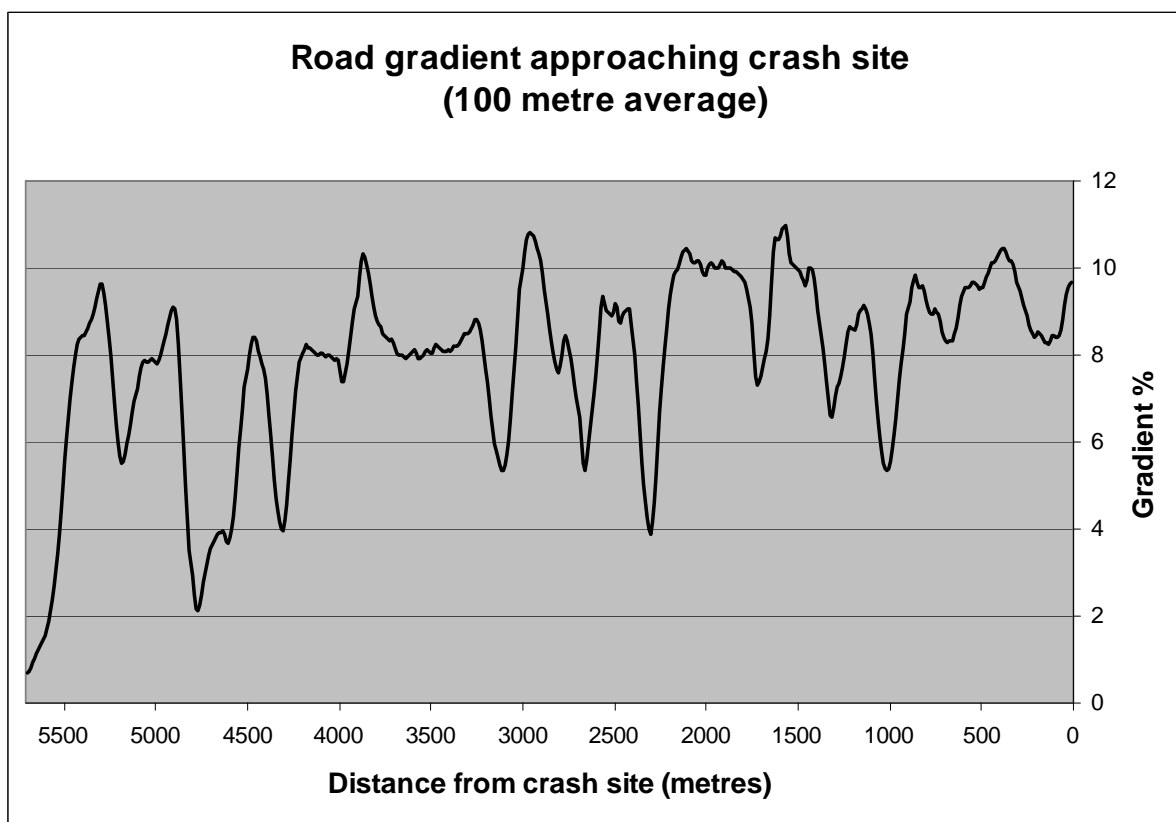

Figure 2: Road gradient approaching crash site

Signage

- 1.15 Australian Standard AS1742.2 - 2009, *Manual of Uniform Traffic Control Devices, Part 2 Traffic Control Devices for General Use*, includes a diagram for use in the classification of road gradients (see *Figure 3*).¹

¹ The existing signage was installed in accordance with the *Interim Guide to Signs and Markings*, the previous standard utilised by the RTA.

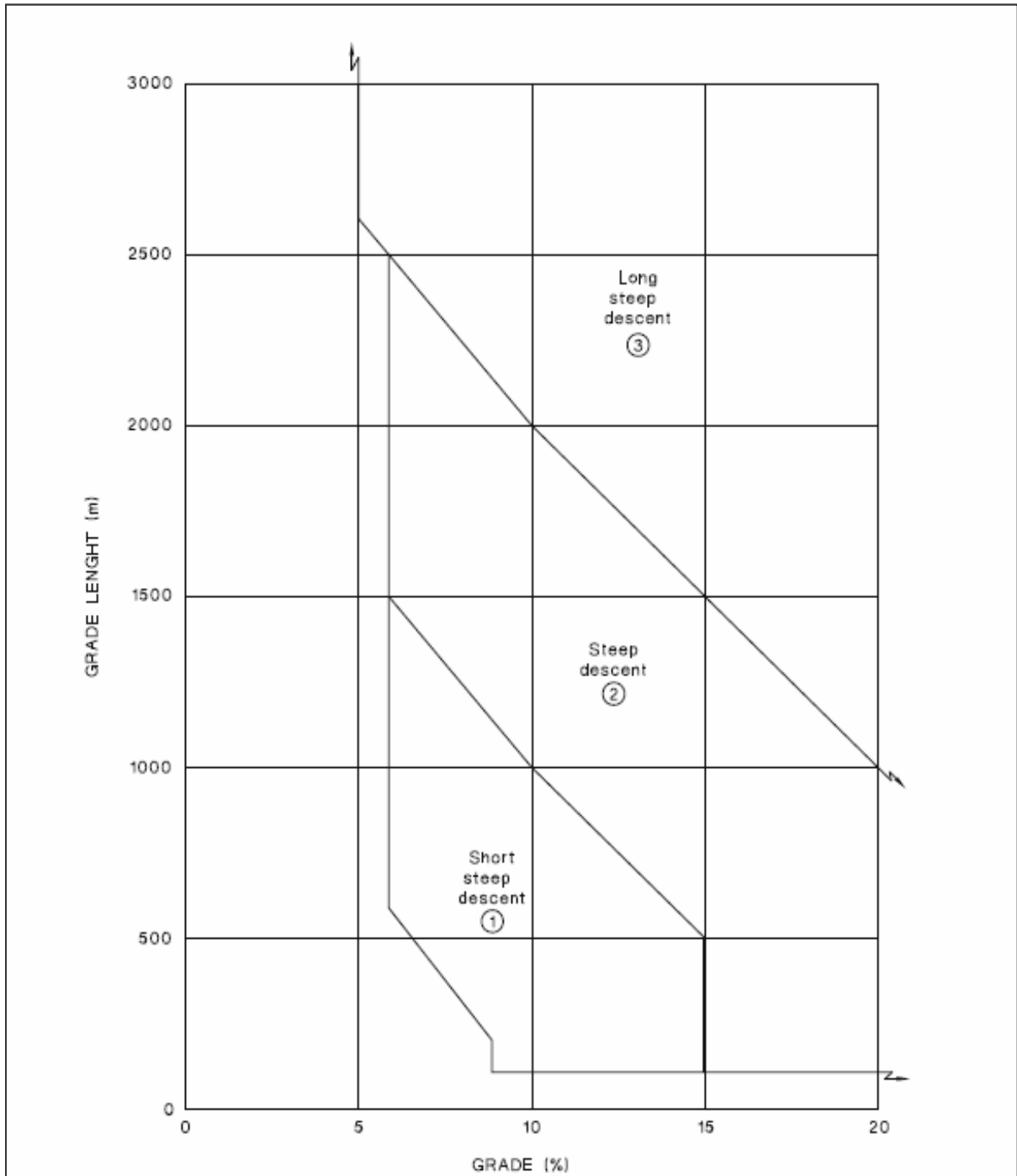

Figure 3: Gradient classification diagram from AS1742.2 - 2009

- 1.16 The section of road leading to the crash location meets the parameters for classification as a “Long Steep Descent”. The appropriate signage would be that shown in *Figure 4*, used in advance of the descent, and supplemented with the sign shown in *Figure 5*, indicating that trucks and buses must use a gear low enough to control the speed of the vehicle without use of the brakes.

This sign must also stipulate the distance for which the restriction applies, or must be paired with an “END TRUCK & BUS LOW GEAR AREA” sign.



Figure 4: Long Steep Descent sign



Figure 5: Sign requiring use of low gear

1.17 In other areas similar to the Barrengarry area, signs are used to warn drivers of heavy vehicles to engage low range and to travel with caution. On the Moss Vale Road from Fitzroy Falls to Kangaroo Valley there are no signs to warn drivers of heavy motor vehicles to engage a low gear. The only sign that signifies a steep gradient ahead is one sign positioned just prior to the start of the steep section.

1.18 The descending roadway prior to the point of the accident has the following signs:



- "Next 5km" sign located 5.5km before the accident site;
- a 60km/h speed limit sign 6km before the accident site;
- "Beware Trucks on Curves Next (X) km" at 6km, 5km, 4km, 3km, 2km and 1km before the accident site;
- "Reduce Speed When Wet Next 6km" 5.5km before the accident site;
- "Reduce Speed When Wet Next 3km" 2.5km before the accident.
- a number of temporary signs relating to road works approximately 2km before the accident site:
- a "Stock Crossing" sign 1.5km before the accident site; and

- common curve and advisory speed signs, including 45km/h and 25km/h advisory speed signs for curves shortly before and at the accident site respectively.

Possible Escape Route

1.19 On 18 May 2010, OTSI investigators revisited the site of the accident in daylight. It was noted that, directly adjacent to the accident site, the terrain was level with a slightly falling gradient and sparsely treed bushland (see *Photograph 4*). If this had been known to the driver, it could have provided a safe runoff as an alternative to trying to negotiate a tight (25km/h advisory speed) bend at speed.



Photograph 4: Possible escape route

G&S Mini Bus Pty Ltd

1.20 G&S Mini Bus Pty Ltd is a bus and coach charter company operating in Western and South-Western Sydney. At the time of the accident the Company had accreditation from Transport NSW (TNSW) for 14 buses and coaches which were usually stored on its Bringelly property.

- 1.21 In the past, the Company had predominantly operated local services for schools and small chartered groups. It was only in recent times that the Company had embarked on an expansion program of longer distance operations, taking on charter services to places such as Canberra, Jenolan Caves, the Hunter region and other areas further away from Sydney.
- 1.22 In February 2009, G&S Mini Bus purchased five used buses and coaches from another local bus company trading as Steve's Mini Bus and Tours. The vehicle involved in the accident, TV3574, was one of the vehicles purchased in the sale. The sale also included charter and business contracts that Steve's Mini Bus and Tours had acquired throughout its operations, and the transfer of some drivers.

The Driver

- 1.23 The driver of TV3574 was the sole Owner/Director of G&S Mini Bus. In the two weeks leading up to the accident, he had only worked on a few occasions. On Monday 10 May 2010, he conducted a short local community run. The next day he drove TV3574 to Canberra and return. He did no further driving duties until the day of the accident. On the morning of the accident he performed a small local run and returned to the Bringelly property. He then departed the premises at approximately 3.30pm in order to prepare the vehicle for the trip to Kangaroo Valley. No evidence was found to suggest that fatigue was a contributing factor in the accident.
- 1.24 A toxicology report on the driver, provided by the New South Wales Department of Health, indicated that there were no traces of alcohol or any of the other tested psychotropic drug groups present.

Other Drivers of Coach TV 3574

- 1.25 Throughout the investigation, a number of bus and coach drivers who had operated vehicle TV3574 were interviewed. One of the drivers, who had worked for G&S Mini Bus for a period of six months, stated that he had operated the coach on a number of occasions and had experienced problems with the vehicle.
- 1.26 The first time he had driven the coach was when he was required to collect it from a heavy vehicle mechanical repairer. The son of the owner had

accompanied him. The automatic transmission of the coach had failed previously and required a full rebuild. After collecting the vehicle and departing the repairer's premises, he approached a major intersection and immediately noted that the vehicle's retarder was not working.

- 1.27 Another defect that immediately came to his attention was that the four speed automatic transmission was intermittently jumping from low range and engaging a higher range than had been selected. He travelled from Milperra to Bringelly and tried to utilise the retarder on a number of occasions, but it did not respond. The driver made a comment about these defects to the owner's son while returning to Bringelly and also reported the defects to the owner of G&S Mini Bus on arrival. He stated that the owner noted it and said he would rectify the problem.
- 1.28 This driver operated the vehicle on a number of occasions after the transmission had been repaired, but noted that on every occasion the vehicle's retarder did not work. He reported the defect to the owner's son and to the owner's wife, but it was never repaired. Throughout the time he was employed to drive the vehicle, it would frequently shift into a higher range than selected, but the vehicle was never returned to the repairer. He added that he found this unusual as the cost of the repairs to the transmission was in excess of \$10,000 and he couldn't understand why the vehicle wasn't returned for repair under warranty.
- 1.29 The driver added that at no time while he operated the coach did the retarder ever work. On two separate occasions he found himself in a potentially dangerous situation when he couldn't control the vehicle while descending a steep gradient.
- 1.30 One of these events occurred on 2 December 2009 while descending Bulli Pass on a trip to Wollongong. He began the descent at the top of the Bulli Pass as normal but, as the vehicle's retarder did not work, the coach began to gain momentum. Concurrently, the transmission would not stay in low range and kept jumping into a higher range. By the time he had reached the bottom of the gradient the coach's brakes were ineffective due to severe brake 'fade'. As he approached a set of traffic lights showing red, he was unable to stop

and rolled through the intersection against a red light. The only reason he avoided an accident was that the brake 'fade' occurred at the bottom of the gradient on a dual carriageway and in good traffic conditions. He said that, had this occurred on a more treacherous road similar to Macquarie Pass or Moss Vale Road in the Barrengarry Nature Reserve, he believes the consequences could have been "*drastic*".

- 1.31 On 10 December 2009, again travelling down Bulli Pass and cognisant of his experience on the previous trip, he engaged 'low range' and travelled at an extremely slow speed. He noted he had to make several comments to the passengers as they were curious as to why he was descending the gradient with such care. He told them that he was just being courteous and allowing other drivers to pass. However, he stated to OTSI that the real reason was that he didn't want to alarm the passengers about the vehicle's tendency to run away. When he returned to the Bringelly property, he made a comment to the owner's wife who stated that she would have her son return the vehicle for repair.
- 1.32 The owner's son (who also drove the coach) supported the claim that the retarder did not work when leaving the repairer's premises. He said that, while waiting outside a local school some weeks after the pickup date of 2 October 2009, he was talking to another bus driver about the defective retarder. This driver informed him that generally, if the retarder does not work, it is due to a wire that has come adrift either under the dash or on the side of the transmission. While waiting at the school, the son positioned himself under the coach and noted that a wire with a spade connector was disconnected. He reconnected the wire and found the retarder then worked perfectly.
- 1.33 After receiving this information, OTSI interviewed several other drivers. One of these drivers stated that he had driven for G&S Mini Bus for approximately 12 months and previously for Steve's Mini Bus and Tours for six years. He said that he had driven TV3574 on many occasions in the six years and had come to know the coach's characteristics very well.

- 1.34 This driver remarked that, after taking up employment with G&S Mini Bus, the first time he became aware that the retarder was not working was on 10 October 2009 on a charter for a social group to Jenolan Caves. He had reached the summit of Victoria Pass in the Blue Mountains and had engaged second range, then switched on the retarder using the switch located on the dash which energises the solenoid to activate the retarder. He said the retarder was not working which concerned him at the time as he had already begun to descend Victoria Pass. He added that he then engaged the lowest range available and travelled with extreme caution, controlling the speed of the vehicle by using low range and the service brake.
- 1.35 The driver contacted the owner's son and informed him that the retarder was not working. He also told the owner that he was displeased with the vehicle. When asked if he had ever logged this in a defect book, the driver stated that there was no defect book and that defects were passed on verbally, generally to the owner's son. This method of reporting defects was accepted practice although G&S Mini Bus advised that instructions had always been for drivers to record any defects in the "Comments or Any Special Requirements" section of the standard "Drivers Manifest".

The Coach

- 1.36 The coach's chassis was manufactured by Motor Coach Australia in June 1986 as a two axle vehicle with a GVM of 16,000kg (see *Figure 6*). The Austral Starliner² body was built by Austral Group Manufacturing. The vehicle was authorised to carry 53 seated occupants and to stand 19 (see *Figure 7*). The engine was a centre mounted Cummins LT10-250 six cylinder in-line four stroke diesel. When the vehicle was first built it was fitted with a manual Spicer SST six speed transmission, but this was later changed to an Allison MTB 647 automatic.

² Shown as a Metroliner on the Compliance Plate.

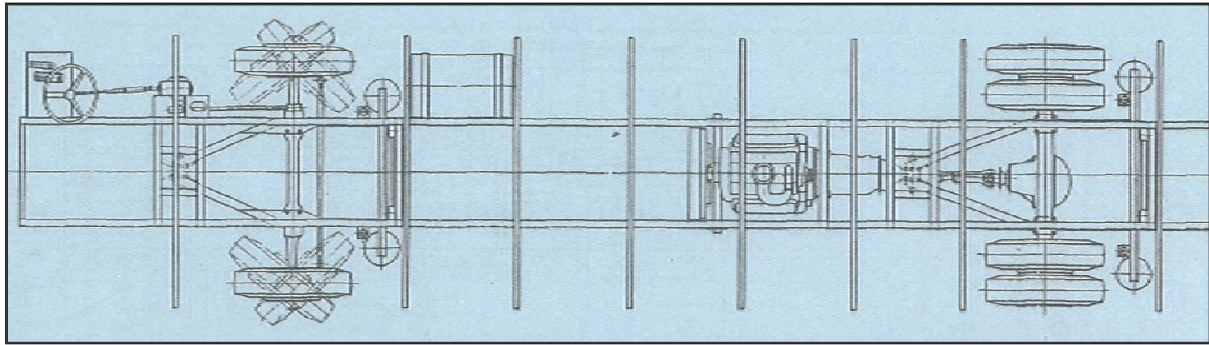

Figure 6: Schematic of coach chassis

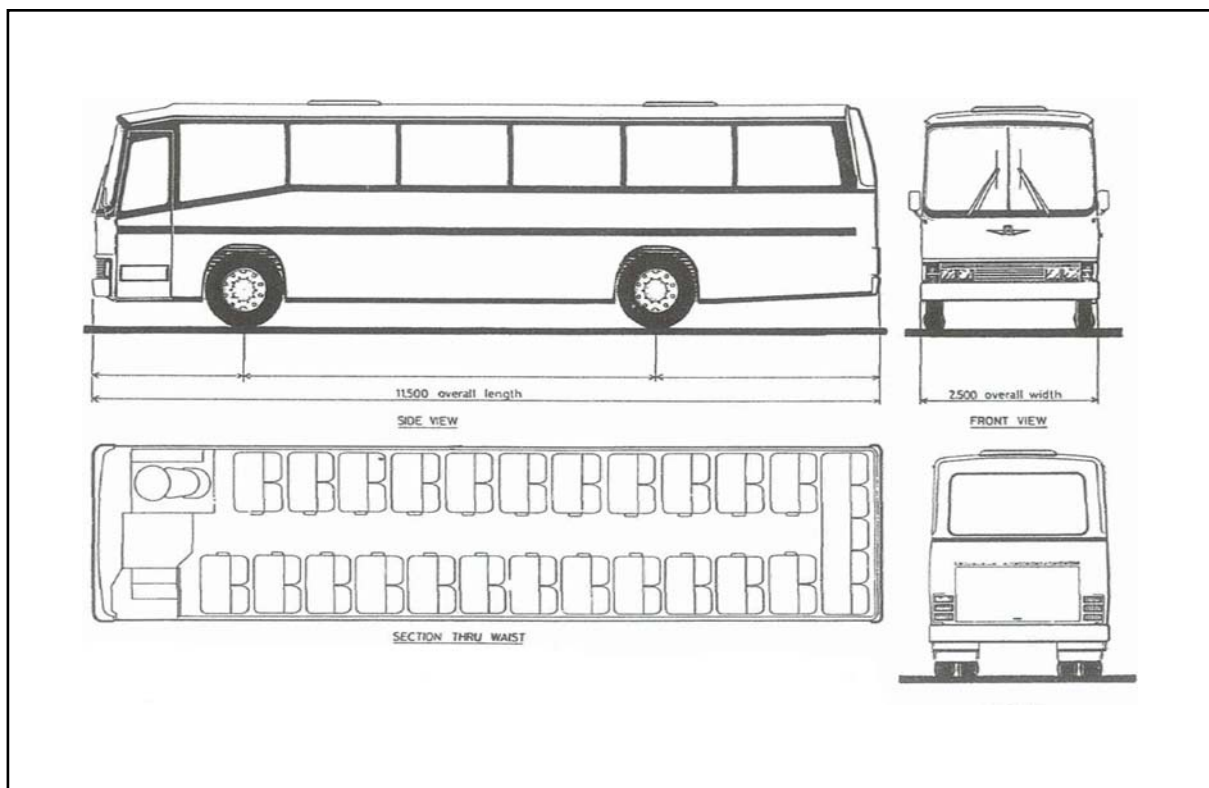
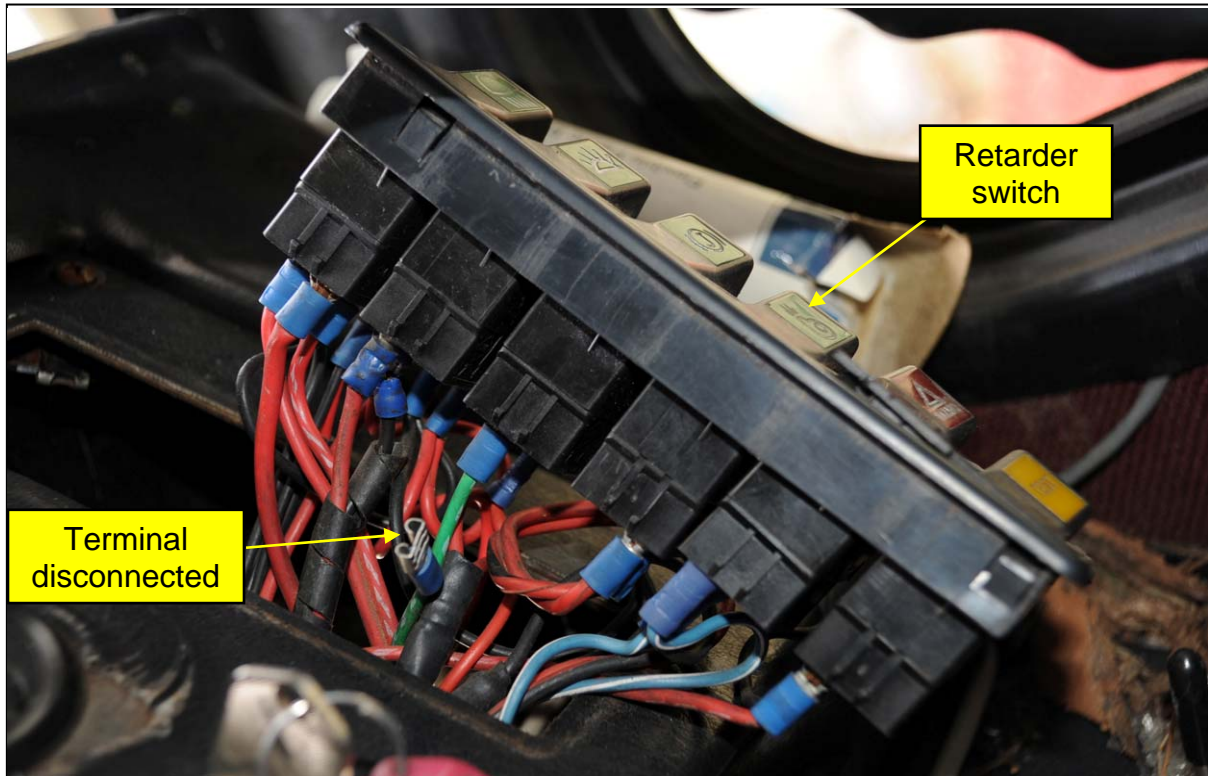

Figure 7: Coach body and seating arrangement

Allison MTB647 Transmission

1.37 The Allison MTB 647 is a four speed automatic transmission. When operating in fully automatic mode (the selector in the 'D' position) the transmission will shift automatically to the appropriate gear for the current speed and engine operating conditions. When a lower range is selected (1, 2 or 3 on the selector), shifting into a gear higher than indicated by the range is inhibited. This allows use of a lower gear and hence a higher engine speed than normal, to provide additional engine braking. However, shifting into a

higher gear will take place if needed to prevent the engine from exceeding its maximum governed speed. The transmission will also inhibit a shift into any range at a speed that would cause engine overspeed, delaying the actual engagement of the gear until the road speed is reduced.



Photograph 5: Retarder switch disconnected

Retarder

- 1.38 The transmission on the coach was fitted with an output retarder to reduce the demand on the service brakes. The retarder utilised the transmission fluid as a braking medium, using the transmission cooler to dissipate the heat generated by its operation.
- 1.39 In the case of TV3574, the retarder was turned on by means of a switch originally intended to actuate a Jacobs compression release brake (commonly known as a 'Jake brake'). When switched on, the retarder was designed to function automatically, providing retardation when the accelerator was released. On examination, it was found that the switch had been disconnected, as can be seen in *Photograph 5*, and that the electrical connection to the retarder solenoid had also been disconnected, as shown in *Photograph 6*.

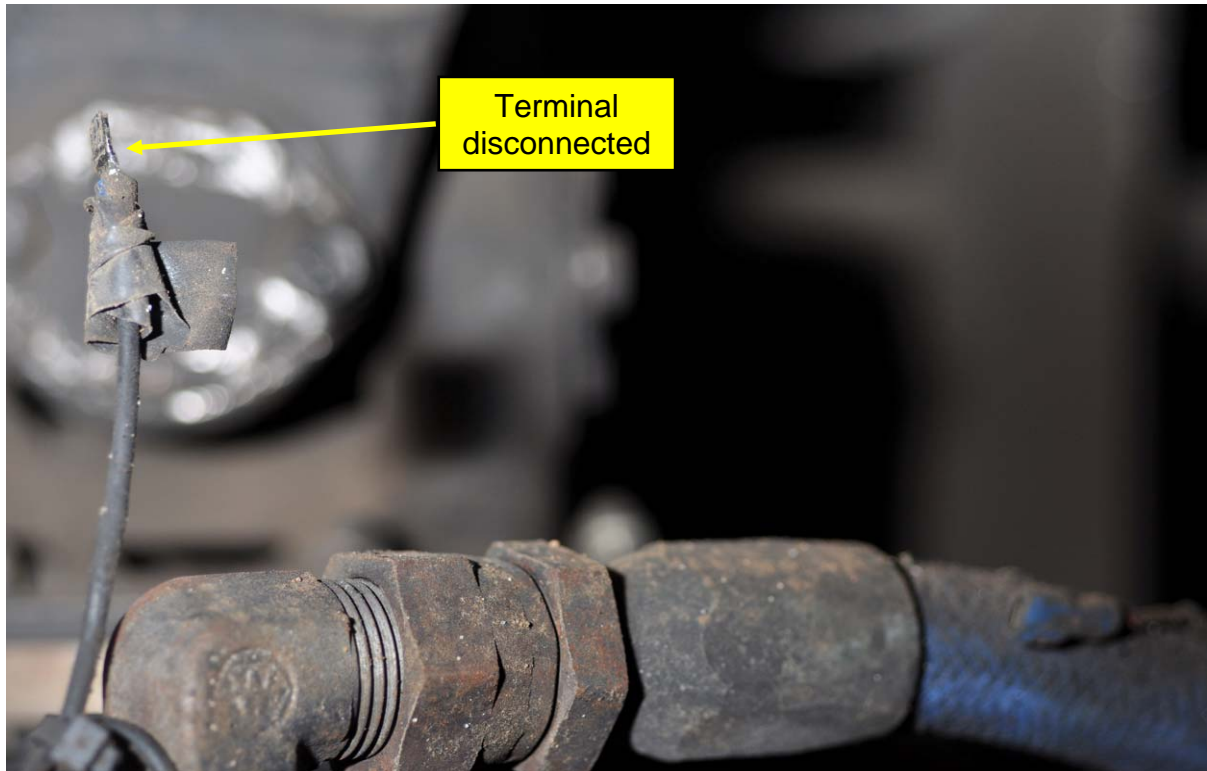

Photograph 6: Retarder disconnected

- 1.40 OTSI interviewed a number of experienced bus, coach and truck drivers including a driver who had driven the bus for six years when it was operated by Steve's Mini Bus and Tours. It was the common view of the drivers interviewed that correct use of the retarder enhances the effectiveness of the service brakes and would have assisted the driver to have maintained control of the coach when descending from Fitzroy Falls to Kangaroo Valley.
- 1.41 Although effective, the retarder was of an older design, dating from 1982. A disadvantage of this type of retarder is that the unit uses the transmission fluid to transfer heat from the retarder to the transmission cooler and may build up high temperature levels within the gearbox. The driver must constantly monitor the transmission fluid temperature, and if too much heat is generated, must switch off the unit in order for the transmission to cool down. Several of the drivers who had previously driven the coach agreed that it wasn't too difficult to operate but the driver had to be mindful of the transmission temperature.

Brakes

1.42 The coach was fitted with S-cam type drum brakes (see *Figure 8*). Brake adjustment, required at regular intervals in order to maintain effective brake operation, was performed manually, unlike in later model vehicles from the mid-nineties where automatic adjustment was generally provided.

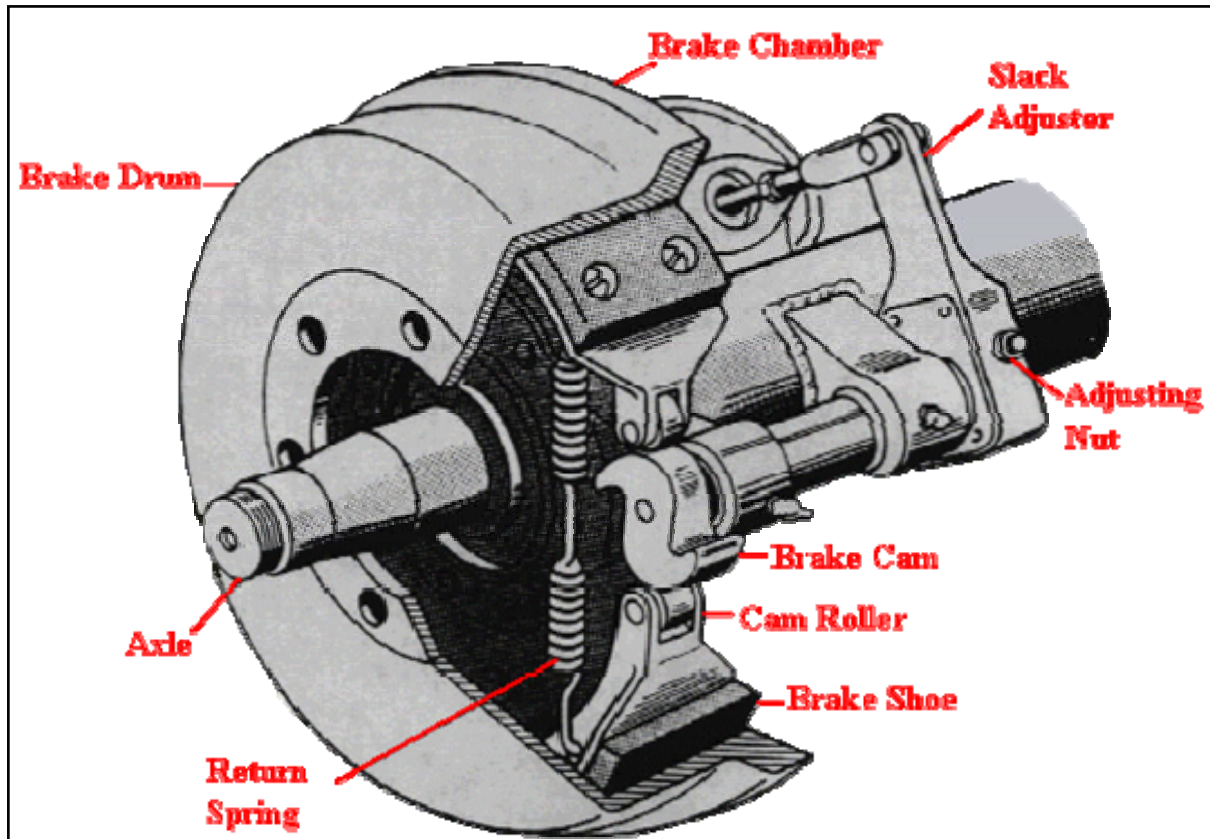

Figure 8: Rear brake assembly

1.43 As the rear axle of the coach was designed to carry more than 60% of its laden mass, the rear brakes were intended to supply the majority of the vehicle's braking effort. In the event of the rear brakes becoming ineffective, an excessive proportion of the vehicle's braking effort would have to be performed by the front brakes. Since the contribution of the front brakes is limited by the proportion of the vehicle's mass carried by the front axle, total braking effectiveness is reduced and the front brakes tend to overheat with extended use. This eventually results in the front brakes becoming ineffective ('fading') and the vehicle becoming a runaway.

Previous Defects

- 1.44 The most recent documented inspection of the bus was a RTA Heavy Vehicle Inspection Scheme (HVIS) roadworthiness inspection carried out on 3 May 2010. Buses which seat more than eight adults and are used to provide a public passenger service must undergo HVIS inspections twice a year.
- 1.45 At this inspection, the vehicle was defected for a number of issues, the most serious being a more than 30% brake imbalance between wheels. The company was given 24 hours to have the defects rectified in order to have the notice cleared and the bus returned to service.
- 1.46 The vehicle was then driven to the Bringelly property where the vehicle's rear brakes were adjusted by the mechanic employed by G&S Mini Bus. This mechanic conducted most of the maintenance work on the Company's 14 buses and coaches.
- 1.47 On 5 May 2010 the vehicle was driven to G&S Diesel based at Narellan on the outskirts of Sydney.³ The vehicle was inspected by an RTA authorised examiner, the defect was cleared and the vehicle was returned to service.
- 1.48 RTA records showed that since the purchase of the vehicle by G&S Mini Bus, several defects had been cleared at the Narellan location (see *Table 1*).

Mechanical Repairers / Maintenance

- 1.49 In order to have a better understanding of the maintenance history of vehicle TV3574, OTSI visited three locations that had direct involvement with it.

G&S Mini Bus Pty Ltd Workshop

- 1.50 OTSI attended the premises of G&S Mini Bus at Bringelly in order to inspect the storage and repair facilities for its buses and coaches. The facilities did not have a hoist or pit to provide easy access to underbody components of a coach, but did have a large hydraulic trolley jack suitable for lifting a heavy vehicle for wheel, tyre, hub and brake servicing. Overall the premises housed an appropriate range of equipment for general maintenance work, but would have had difficulty supporting major repairs such as transmission rebuilds.

³ Despite the similarity in names there is no association between G&S Diesel and G&S Mini Bus.

Date	Defect	Location Issued	Location Cleared	Allocated Time to Repair Defects	Date Cleared
03/05/2010	Brakes Wheels/Tyres Oil/Fuel Leaks Ancillary Equipment	Campbelltown	Narellan G&S Diesel	24 Hours	05/05/2010
22/03/2010	Wheels/Tyres Exhaust/Noise Ancillary Equipment	Erskine Park	Narellan G&S Diesel	48 Hours	23/03/2010
29/10/2009	Wheels/Tyres Oil/Fuel Leaks Body/Chassis Ancillary Equipment	Campbelltown	Narellan G&S Diesel	48 Hours	29/10/2009

Table 1: Defects since purchased by G&S Mini Bus

- 1.51 G&S Mini Bus employed a mechanic on a casual basis. The mechanic had been employed by G&S Mini Bus for the past three years, generally working approximately 30 hours a week. He stated that he usually wasn't too busy, just working at a consistent pace. The mechanic held a Tradesperson's Certificate issued by the Motor Vehicle Repair Industry Council⁴ for work as a Motor Mechanic, conducting repairs to all classes of motor vehicle, but had no specialised qualifications for working on heavy vehicles.
- 1.52 When interviewed, the mechanic stated that he conducted general repairs on all the vehicles including maintenance of the brakes. If he felt a job was too difficult for his level of expertise, he would outsource the work. He added that the transmission rebuild was one of those jobs that was simply too difficult to do, so the job was outsourced to a repairer at Milperra.
- 1.53 On 3 May 2010, when the RTA had 'defected' the vehicle for unbalanced braking, the mechanic adjusted the vehicle's rear brakes and had the vehicle test driven twice in order to obtain the correct balance. As he did not then possess a NSW driver's licence, he utilised the son of the owner of G&S Mini Bus to test drive the vehicle. The son confirmed this and stated that the

⁴ Now known as the Motor Vehicle Repair Industry Authority.

brakes were fine when he had test driven the vehicle. He added that he had driven the coach to an RTA authorised inspection station to have the defect cleared. However, when the owner of the inspection station was interviewed, he stated that the son had not driven the coach to the repairer's workplace and that it was driven by a person unknown to him.

- 1.54 When maintenance records for the repairs were sought, it was found that neither the mechanic nor G&S Mini Bus had any formal record keeping procedures covering maintenance work. The owner's son was identified by the drivers as the person with whom they discussed any maintenance issues, as he managed the maintenance side of the business. However, no work orders were raised and the mechanic did not keep a work diary.
- 1.55 When asked if he held a mechanical trade certificate, the son replied that he had one remaining subject to pass in order to complete his Tradesperson's Certificate as a Motor Mechanic. He was very critical of the other drivers' use of the retarder and believed the manner in which it was used by one particular driver was the reason a transmission rebuild had been required.

Heavy Vehicle Repairer

- 1.56 The rebuild of the vehicle's transmission, previously referred to in paragraphs 1.26 - 1.28, was performed by a heavy vehicle repairer in Milperra utilised by G&S Mini Bus for major repairs to all its vehicles. The date of the tax invoice for the repairs was 2 October 2009. The repairer stated that the vehicle had been test driven on a number of occasions over the three days after completion of the repair and prior to being collected by G&S Mini Bus, and that the vehicle had performed in a satisfactory manner. The repairer was unable to provide a check list used for the testing regime, stating that records of such testing were not kept as the test simply involved observation of the vehicle's on-road behaviour.
- 1.57 The repairer advised that the vehicle was supposed to be returned for a general service after travelling 1,000km and then after 10,000km as part of the ongoing service regime, though this service regime appears not to have been clear to G&S Mini Bus. He was surprised that the vehicle had not been returned for the 1,000km service and for rectification of any recorded defects,

particularly in reference to a claim that the transmission was malfunctioning and the retarder was not working when the coach left the repairer's premises.

Heavy Vehicle Authorised Inspection Station

- 1.58 On 5 May 2010 the vehicle was taken to a motor vehicle repairer authorised by the RTA to inspect heavy vehicles and clear defect notices. The vehicle examiner clearly remembered the day the vehicle was brought to him. He stated that he crawled under the coach to ensure that the brakes had been adjusted. He added that he viewed the brake shoes through the inspection holes and noted that they were almost touching the brake drum and had been fully adjusted.
- 1.59 He took the vehicle for a drive utilising a decelerometer to measure its deceleration when braking, to ensure that the vehicle's braking performance satisfied the current requirements. He stated that there was no concern with the brakes and that at one point the brakes actually locked up. He added that the vehicle stopped satisfactorily and stayed straight as required, indicating that the brakes were balanced.
- 1.60 When OTSI visited the premises, it was found that the business did not keep records of defect notices cleared. It is noted, however, that the RTA is developing an online defect clearance facility which will produce a vehicle defect notice clearance report. A copy of the report will be kept at the Heavy Vehicle Authorised Inspection Station (HVAIS) and an electronic copy will be retained on the RTA's electronic HVAIS online system. The system will automatically create records of defect clearances. Once the system has been developed, it will be compulsory for all HVAIS to use it.

OTSI/Police/RTA Inspection

- 1.61 After the accident, the vehicle was taken to the Albion Park Police Holding Compound where it was inspected by RTA heavy vehicle examiners, OTSI investigators and the Police. After an initial inspection it was decided that, in order to adequately test the brakes, the vehicle would require all air lines to be repaired and for the vehicle to be in a functional state. The vehicle was then transferred to the Police Engineering Investigation Section at Zetland where it was repaired to a functional state over several months. On 6

October 2010 Police, RTA, an independent vehicle insurance inspector and OTSI conducted an inspection of the vehicle. The vehicle was tested using the RTA's Vehicle Inspection Trailer (VIT) (see *Photograph 7*), which checks brake balance and effectiveness as well as looseness in the suspension and steering.



Photograph 7: Coach being placed on RTA VIT

- 1.62 The test concluded that the suspension of the vehicle was satisfactory and would have passed the required heavy vehicle inspection scheme (HVIS) testing regime under which all public passenger vehicles seating nine or more passengers must be inspected twice a year by the RTA. However, the test revealed that, although the front brakes were effective and balanced, the rear brakes were severely out of balance by 41%, and so were ineffective. Currently in NSW the maximum allowable imbalance level is 30%.
- 1.63 While the coach was on the VIT the rear brake inspection holes were viewed and photographed. *Photograph 8* shows clearly that there is no brake lining visible through the brake inspection hole. This contradicts the recollection of the examiner at the HVAIS that the coach had ample brake material and braked in a balanced manner when he drove it.



Photograph 8: View of inspection hole of rear brakes in the applied position

- 1.64 OTSI contacted several bus organisations to determine the rate of brake lining wear a coach of this type might experience. Their opinion was that a metropolitan bus which experiences frequent braking throughout a typical shift requires brake re-lining every 60,000 to 100,000km depending on the type of vehicle and the type of use. Coaches generally travel much further without requiring new linings as brake use is less than for metropolitan buses. The coach had only travelled 4,000km since the brake defect was cleared.
- 1.65 After the brake tests had been completed, the wheels and brake drums were removed. It was found that the front brake linings were in good condition and appeared to have recently been replaced. However, the friction surfaces of the brake drums were blue in colour signifying that the brakes had reached extreme temperatures during recent use. On the night of the accident, RTA Inspectors had noted that the front brakes were still hot to touch one hour after the accident.

- 1.66 On inspection of the rear brakes, it was found that the brake linings had disintegrated so that the rivets had been contacting the brake drum (see *Photograph 9*). Furthermore, the brakes had been over-adjusted so that the S-cams were fully rotated as can be seen in *Photograph 10*, and were incapable of applying any pressure to the brake shoes.

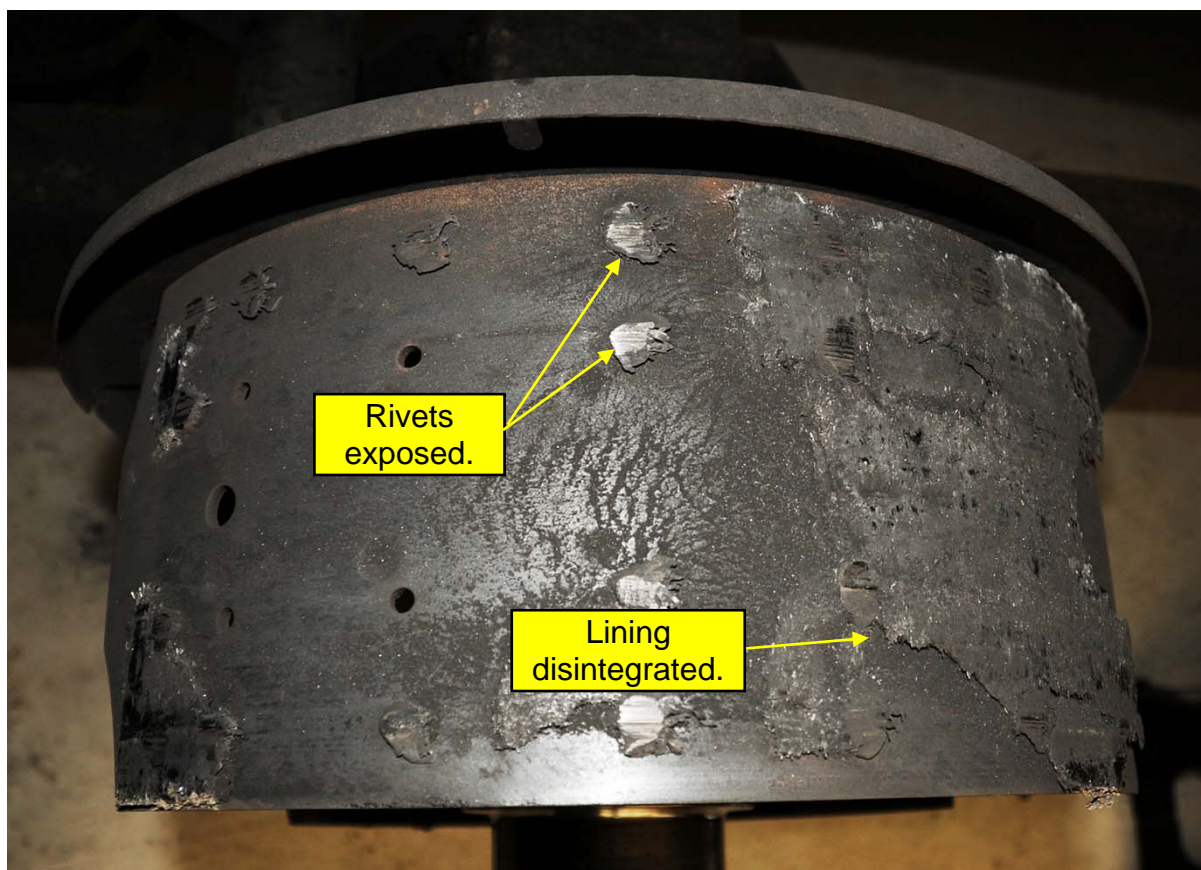

Photograph 9: Rear brake lining disintegration and exposed rivets

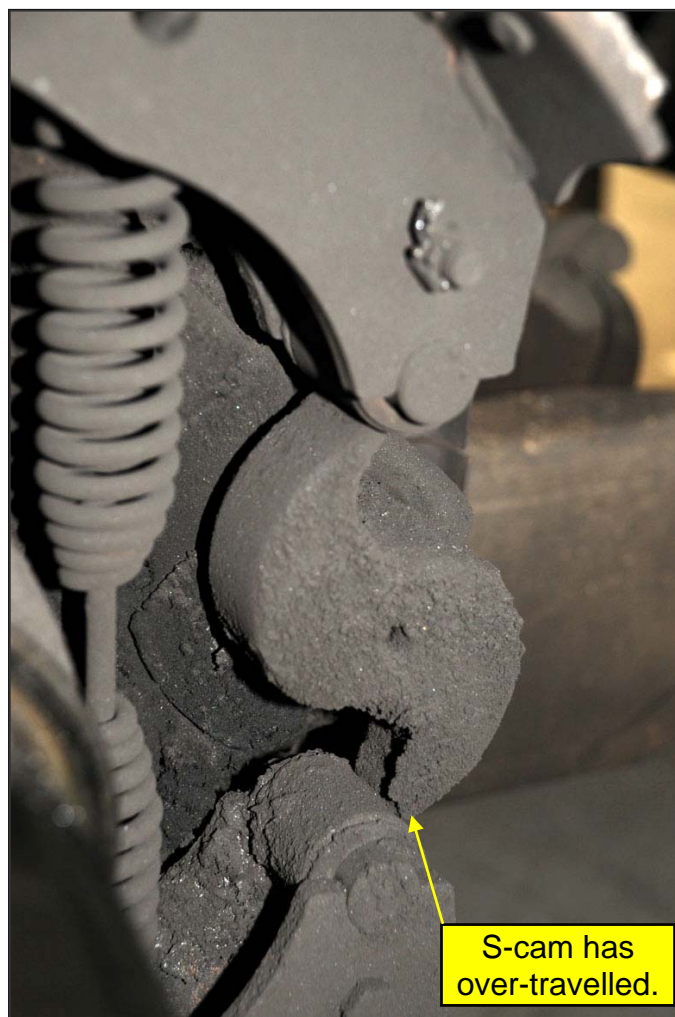

Photograph 10: The S cam clearly over stroked

- 1.67 The manual slack adjusters at the rear of the brake assembly were found to be covered with thick grime from a combination of grease and dirt (see *Photograph 11*). This indicated the brakes had not been adjusted for a considerable time, contrary to the statements by both the G&S Mini Bus mechanic and the RTA authorised examiner that the brakes had been adjusted several times and were in good order just 11 days prior to the accident.



Photograph 11: Condition of brake slack adjuster

NSW Bus Operator Accreditation Annual Self Assessment Report

- 1.68 On 1 July 2005 the (then) Ministry of Transport introduced the Bus Operator Accreditation Scheme (BOAS) as part of a wider bus reform process. Under the BOAS, operators are accredited for a period of three years, and can be re-accredited following an independent audit of their operation. The operator must also complete and submit an Annual Self Assessment Report (ASAR).
- 1.69 G&S Mini Bus completed ASARs in 2007, 2008 and 2009. With its 2007 ASAR, G&S Mini Bus acknowledged that its Safety Management System (SMS) was not set out in accordance with the guidelines in the SMS Handbook issued by TNSW. Additionally, the required Drug and Alcohol Program was not yet in place. TNSW then directed G&S Mini Bus to rectify the issues with its SMS and Drug and Alcohol Program. In response to a further prompt, G&S Mini Bus wrote to TNSW in December 2007 confirming they now complied with SMS requirements. The subsequent 2008 and 2009 ASARs claimed all the accreditation requirements were satisfied, including

the presence of a Vehicle Maintenance Plan consistent with manufacturer's maintenance guidelines, and a Vehicle Defect and Repair System.

- 1.70 Although the BOAS was introduced in 2005, independent audits did not commence until December 2007 and were scheduled to be conducted over a three year period. G&S Mini Bus' initial external audit was scheduled for August 2010.
- 1.71 The program of initial external audits has now been completed and new operators are scheduled to have an independent audit within six to twelve months of accreditation being issued.

Other Safety Issues

Motor Mechanic Qualifications

- 1.72 Currently in NSW any person qualified as a motor mechanic can work on all classes of motor vehicles including heavy vehicles. Despite the major differences in critical systems such as brakes in light and heavy vehicles, there is no impediment to a mechanic with only light vehicle training and experience working on heavy vehicles.
- 1.73 Although the Technical and Further Education system (TAFE) provides a range of specialised courses related to heavy road transport and other heavy vehicle categories, a single Tradesperson's Certificate covers all categories and makes it legal for the holder of a certificate as a Motor Mechanic to work on all categories of vehicle. It is likely that the poor brake and retarder maintenance found on TV3574 in this investigation was due in part to a lack of expertise on the part of the (light) vehicle mechanic performing the basic maintenance work.

Data Recording Devices

- 1.74 TV3574 was fitted with a Keinzle Tachograph and a Tacholink On-Board Computer, both capable of recording a number of vehicle operating parameters.
- 1.75 The Keinzle Tachograph, which records vehicle information on a circular chart, also functioned as the vehicle's speedometer and tachometer. When examined at the crash site it was found to have no chart fitted, and

consequently provided no record of the vehicle's operation. When asked to provide Tachograph records of previous trips, G&S Mini Bus was unable to do so.

- 1.76 The Tacholink unit, an electronic data logger, was found to be disconnected. When it was examined by the manufacturer, Circuitlink International, it was found to have a flat backup battery, with the result that no data had been retained.
- 1.77 In accordance with Part 5, Division 2 of the *Road Transport (Safety and Traffic Management) Act 1999*, any bus operating a charter service beyond a radius of 80km from its depot must be fitted with a monitoring device which records vehicle movement. These records must be preserved for three years. The charter service involved in the accident exceeded the 80km radius criterion.

Age of Fleet

- 1.78 Currently in NSW there is no limit on the age of coaches that can be used for charter services. In contrast, the maximum average age of bus fleets used to provide regular passenger services may not exceed 12 years and the maximum age of any vehicle in the fleet may not exceed 25 years. The average age of the G&S Mini Bus fleet was 23 years, with the oldest bus being 32 years old and the youngest 13 years old. The smaller buses with seating for less than 30 occupants were all less than 18 years old, while the larger buses with seating for over 40 were all older, with the youngest being 22 years old.
- 1.79 Since the manufacture of these larger buses, significant changes have occurred in relation to bus design. TV3574 was a 1986 coach that did not have ABS brakes or automatic brake slack adjusters, and the gearbox retarder was of an older design requiring the driver to constantly monitor the transmission fluid temperature to guard against overheating. None of these older buses was required to be fitted with passenger seat belts or, in most cases, driver seatbelts, or to meet rollover safety requirements.

Status of G&S Mini Bus

1.80 As the driver fatally injured in the accident was the sole director/designated manager of G&S Mini Bus, TNSW was obliged to cancel its accreditation, with effect 17 May 2010, pursuant to Section 10 of the *Passenger Transport Act 1990*. Additionally, all vehicles registered to G&S Mini Bus Pty Ltd, used to conduct public passenger services prior to the accident, were requested to undergo heavy vehicle inspections at the RTA to ensure roadworthiness. Inspection reports provided to the Department of Transport confirmed compliance.

PART 2 FINDINGS

Causation

- 2.1 Coach TV3574 was unable to negotiate a sharp left hand bend on a steep descent, causing it to run off the road, crash through a guard rail and down a steep slope because the vehicle's brakes could not control the speed of the vehicle.
- 2.2 The inability of the brakes to function as intended is attributable to the fact that:
- the rear brakes were ineffective, having been allowed to deteriorate to the extent that the linings had disintegrated and the brakes could no longer be effectively adjusted;
 - the transmission output retarder, intended to reduce the demand on the service brakes, was disconnected; and
 - although in good condition prior to the trip, the front brakes could not meet the demand placed on them as a result of the lack of effective rear brakes and retarder.

Contributory Factors

- 2.3 The approach to maintenance adopted by G&S Mini Bus in relation to TV3574 was reactive in nature, taking only sufficient action to keep the vehicle in service, rather than following the manufacturers' preventative maintenance schedules.
- 2.4 A defect notice issued by the RTA under its Heavy Vehicle Inspection Scheme in regard to the brakes of TV3574 was cleared by an RTA authorised examiner without the defect having been effectively rectified.
- 2.5 The mechanic conducting the routine maintenance of TV3574 had no training and inadequate experience in heavy vehicle repairs. Additionally, he did not have a driver's licence and so was unable to road test the vehicles he had worked on. Instead, he had to rely on the feedback from others conducting the road tests for him.

Other Safety Matters

- 2.6 G&S Mini Bus did not keep a vehicle movement record by means of a suitable monitoring device, as required under the *Road Transport (Safety and Traffic Management) Act 1999*.
- 2.7 G&S Mini Bus was able to retain its accreditation on the basis of a series of three self-assessments prior to an independent audit which was scheduled for August 2010. Deficiencies in maintenance practices and record keeping were not declared in the self-assessments completed for 2008 and 2009. It is reasonable to expect that an independent audit would have readily identified such deficiencies and prompted timely remedial action.
- 2.8 The long, steep descent leading to the accident location was such that additional signage emphasising the gradient and requiring trucks and buses to use low gear was warranted.

PART 3 RECOMMENDATIONS

- 3.1 Since G& S Mini Bus is no longer an accredited operator of public passenger services and the Roads and Traffic Authority has confirmed the roadworthiness of the remaining vehicles, no recommendations are made in relation to the Company.
- 3.2 In relation to the carriageway in the precincts of the Barrengarry Nature Reserve, it is **recommended** that the **NSW Roads and Traffic Authority**:
- reviews the placement of signage on Moss Vale Road from Fitzroy Falls to Barrengarry, and where appropriate, installs additional signage warning of the steep descent and requiring trucks and buses to use low gear; and
 - examines the feasibility of installing an arrester area suitable for both heavy and light vehicles adjacent to the accident location.
- 3.3 It is also **recommended** that the **NSW Roads and Traffic Authority** and the **Department of Transport** review the opportunities or existing systems in place to exchange information on buses that are defected as part of the twice yearly HVIS inspections, with a view to providing information to target compliance activity.

PART 4 APPENDIX

Appendix 1: Sources and Submissions

Sources of Information

- Allison Transmission Australia
- Autoshift Diesel Pty Ltd
- Bus Sales Online
- Daltrans Inc
- Department of Transport
- G&S Mini Bus Pty Ltd
- NSW Ambulance Service
- NSW Coroner
- NSW Police
- NSW Roads and Traffic Authority

Submissions

The Chief investigator forwarded a copy of the Draft Report to the Directly Involved Parties (DIPs) to provide them with the opportunity to contribute to the compilation of the Final Report by verifying the factual information, scrutinising the analysis, findings and recommendations, and to submit recommendations for amendments to the Draft Report that they believed would enhance the accuracy, logic, integrity and resilience of the Investigation Report. The following DIPs were invited to make submissions on the Draft Report:

- G & S Mini Bus
- Independent Transport Safety Regulator
- NSW Police
- NSW Roads and Traffic Authority
- Department of Transport

Submissions were received from the Independent Transport Safety Regulator, the Department of Transport and the NSW Roads and Traffic Authority. The Chief Investigator considered all representations made by DIPs and responded to the author of each of the submissions advising which of their recommended amendments would be incorporated in the Final Report, and those that would not. Where any recommended amendment was excluded, the reasons for doing so were explained.