

**MANUAL
FOR
TRACK MAINTENANCE
(2000)**

SPOORNET

CONTENTS

CHAPTER 1

THE PURPOSE OF THIS MANUAL, IT'S APPLICATION AND ASSOCIATED PUBLICATIONS TO BE READ IN CONJUNCTION HEREWITH

1.0	Purpose of the manual	11
1.1	Application of the manual	11
1.2	Associated publications	11

CHAPTER 2

THE GOAL AND OBJECTIVES FOR TRACK MAINTENANCE. SPECIFIC AND GENERAL RESPONSIBILITIES OF TRACK MAINTENANCE PERSONNEL WITH RESPECT TO THE TRACK INFRASTRUCTURE

2.0	The goal for track maintenance	12
2.1	The objectives for track maintenance	12
2.2	Responsibilities of the Assistant General Manager (Infrastructure-Maintenance),	12
2.3	The Infrastructure Manager,	13
2.4	The Depot Engineer,	13
2.5	The Maintenance Manager (Track) and the Track Inspector (Maintenance Management)	13
2.6	Track personnel in charge of heavy on-track machines,	14
2.7	The Production Manager (Track),	14
2.8	The Engineering Technician,	15
2.9	The Track Master,	15
2.10	The Track Welder,	15
2.11	The Technical Supervisor (Welding), and the Track Inspector (Production); and	16
2.12	of the Track Manager and the Technical Manager (Welding) in the central office.	16
2.13	General responsibilities of track personnel	16
2.13.1	Protection of trains and safeguarding of employees	16
2.13.2	Detonators	17
2.13.3	Safety precautions	17
2.13.4	Safety precautions in station yards	18
2.13.5	Call-outs	18
2.13.6	Breaking of the line	18
2.13.7	Breaking of track circuits	18
2.13.8	Accidents and obstructions	18
2.13.9	Reporting of track defects	20
2.13.10	Goods found next to the track	21
2.13.11	Taking over a length	21
2.13.12	Possession of a reliable watch	21
2.13.13	Communication	21
2.13.14	Absence from section	21
2.13.15	Dangerous substances	21

CHAPTER 3

EARTHWORKS, THE FORMATION, DRAINAGE, TUNNELS, BRIDGES, CULVERTS AND TEMPORARY TRACK SUPPORTS

3.0	Inspection	23
3.1	Earthworks	23

3.2	The formation	23
3.3	Drainage	23
3.4	Tunnels	24
3.5	Bridges and culverts	24
3.6	Temporary track supports	25

CHAPTER 4

INSPECTIONS AND TRACK GEOMETRY

4.0	Inspections general	27
4.0.1	Patrolling	27
4.0.2	Trolley inspections	27
4.0.3	Footplate inspections	28
4.0.4	Inspections by track measuring car	28
4.0.5	Inspection of structures	29
4.0.6	Inspection of earthworks, the formation and associated drainage	29
4.0.7	Ultrasonic and X-ray inspections	29
4.0.8	Inspection of perway material	29
4.0.9	Inspection of sets(turnouts, slips and diamond crossings)	29
4.0.10	Inspection of signs, level crossings and fences	29
4.0.11	Inspection of clearances	30
4.1	Track geometry	30
4.1.1	Standards	30
4.1.2	Transition curves	31
4.1.3	Gauge	31
4.1.4	Cant	32

CHAPTER 5

TURNOUTS, SLIPS AND DIAMOND CROSSINGS

5.0	Introduction	33
5.1	General	33
5.2	Maintenance of stock and points rails	34
5.2.1	General	34
5.2.2	Hinged points blades	34
5.2.3	Flexible type points blades and undercut stock rails	35
5.3	Maintenance of frogs	36
5.4	Points locks and keys	36
5.5	Bridle-locked points	37
5.6	Points boxes	37
5.7	Spiked points	37

CHAPTER 6

RAILS

6.0	The transport and handling of rails	38
6.1	Bending and straightening of rails	38
6.2	Rail usage	38
6.3	Junction rails	39
6.4	Closure rails	39
6.5	Check-railing	40
6.6	Laying rails in track	40

6.6.1	General	40
6.6.2	Jointed track (fishplated rails)	41
6.7	Continuous rails	41
6.7.1	General	41
6.7.2	Track structure for running lines	41
6.7.3	Track structure for yard tracks	42
6.7.4	Laying continuous rails	
	- within the destressing range	42
6.7.5	- outside the destressing range	43
6.7.6	- on new formation	43
6.7.7	- on unballasted bridges	43
6.7.8	Slacks, kinks and kick-outs	43
6.7.9	Continuous rails on sharp curves	44
6.8	Rail joints	44
6.8.1	Fishplated joints	44
6.8.2	Insulating (block) joints	45
6.8.3	Splice joints	45
6.9	Rail creep	46
6.10	Rail destressing	46
6.11	Exothermic welding of rail joints	47
6.12	Repair of battered and mismatched rail ends and welded joints	47
6.13	Repair of wheel spin damage	48
6.14	Broken and defective rails	48
6.15	Rail wear	49
6.16	Rail lubricators	49
6.17	Stop blocks	50
6.18	Derailing devices	50

CHAPTER 7

SLEEPERS AND BALLAST

7.0	Sleepers and fastenings	51
7.0.1	General	51
7.0.2	Inspections	51
7.0.3	Wood sleepers	51
7.0.4	Steel sleepers	52
7.0.5	Concrete sleepers	53
7.0.6	Resleepering by hand under continuous rail	54
7.1	Ballast	54
7.1.1	General	54
7.1.2	Ballast cleaning	54
7.1.3	- by hand	55
7.1.4	- by machine	55
7.1.5	Ballast tamping	55

CHAPTER 8

CLEARANCES AND DIMENSIONS

8.0	Minimum clearances between track and structures	56
8.1	Marking of fouling points	57
8.2	Electrified sections : height of contact wire	57
8.3	Track centres	57

8.4	Clearance marks	58
8.5	Useful dimensions	58

CHAPTER 9

ASSOCIATED WORKS

9.0	Track signs	60
9.1	Grade and kilometre posts	60
9.2	Permanent speed restriction boards	60
9.3	Temporary track signs	61
9.4	Distance and warning boards	62
9.5	Warning signs at level crossings	62
9.6	Level crossings	62
9.7	Service Roads	63
9.8	Fencing	63
9.9	Cattle guards	64
9.10	Beacons	64
9.11	Underground services	64
9.12	Communication routes	65
9.13	Communications	65
9.14	Blasting	65
9.15	Fires	65
9.16	Firebreaks	65
9.17	Plants on or near Transnet or SARCC property	66
9.18	Eradication of noxious weeds	66
9.19	Rodents	66

CHAPTER 10

TRACK MATERIAL, TOOLS AND EQUIPMENT

10.0	Safe keeping	67
10.1	Storage and care of material	67
10.2	Stocks	68
10.3	Released track material	68
10.3.1	Rails	68
10.3.2	Wood sleepers	69
10.3.3	Steel sleepers	69
10.4	Track gauges	69

CHAPTER 11

TROLLEYS AND ON-TRACK MACHINES

11.0	Non self-propelled trolleys	70
11.1	Self-propelled trolleys	71
11.2	Operating of road-rail vehicles	72
11.3	Rail transporters	73
11.4	On-track machines	74

CHAPTER 12**SIGNALS**

12.0	Introduction	76
12.1	Protection	76
12.2	General	76
12.3	Insulating fastenings	76
12.4	Signalling equipment	76

CHAPTER 13**ELECTRICAL**

13.0	Danger of coming into contact with electrical equipment	77
13.1	Rescue and treatment of persons suffering from electric shock	77
13.2	Work under "dead" conditions	77
13.3	Work near "live" electrical equipment and the precautions to be taken	78
13.4	Track/mast alignment	78
13.5	Traction return rail circuit	78
13.6	Prevention of stray return currents	80

CHAPTER 14**TRAIN OPERATING**

14.0	Introduction	81
14.1	Planning	81
14.2	Irregularities / Defects	81
14.3	Communication	81

CHAPTER 15**WORK CODES**

15.0	Ballast	82
15.1	Insulating joints	82
15.2	Bridges and culverts	82
15.3	Earthworks, formation and drainage	82
15.4	Civil Engineering	82
15.5	Track	82
15.6	Rails	82
15.7	Signs, level crossings and fences	82
15.8	Turnouts, slips and diamond crossings	83
15.9	Clearances	83

CHAPTER 16**DECISION MODELS/GUIDELINES**

16.0	Ballast	84
16.1	Concrete sleepers	84
16.2	Track	84
16.3	Rails	84
16.4	Turnout maintenance	84

CHAPTER 17**RAIL/WHEEL INTERACTION**

17.0	Introduction	85
17.1	Geometry	85
17.2	Lubrication	85
17.3	Tracking	85
17.4	Motive power and speed	86
17.5	Profiling	86

CHAPTER 18**PRIVATE SIDINGS**

18.0	Background	87
18.1	Introduction	87
18.2	Definitions	87
18.3	Agreements	87
18.4	Maintenance	87
18.5	Material	87
18.6	Emergency work	88
18.7	Inspections	88
18.8	Rail wear	88
18.9	Sleepers	88

CHAPTER 19**RECOMMENDED READING**

19.0	Books	89
19.1	Conferences	89
19.2	Symposiums, lectures and courses	89

CHAPTER 20

<u>RESPONSIBILITIES AND WORK METHODS APPLICABLE TO SPECIFIC SECTIONS</u>	90
---	----

ANNEXURES

TRACK STRUCTURE

Clearances

- 1/1 Horizontal:- 1 065mm track gauge
- 1/2 Vertical:- 1 065mm track gauge
- 1/3 Platforms
- 1/4 Truck tippler
- 1/5 610mm track gauge

Vehicle gauges

- 2/1 1 065mm track gauge
- 2/2 610mm track gauge

- 3 Classification and standards for running lines:1 065mm track gauge
- 4 Formation and ballast: minimum requirements
- 5 Sleeper spacing
- 6 Safety rails for bridges

Temporary track supports

- 7/1 Rail girders
- 7/2 Sleeper cribs
- 7/3 Bridging cribs

Fastening of bridge sleepers

- 8/1 Hardwood
- 8/2 Laminated timber
- 8/3 Template

Curves

- 9/1 Offsets
- 9/2 Gauge adjustment
- 9/3 Gauge adjustment, side wear and temporary tapered end pieces
- 9/4 Superelevation and maximum permissible speed

Track signs

- 10/1 Permanent
- 10/2 Temporary
- 10/3 Layout
- 10/4 Level crossings

SLEEPERS

Sleeper fastenings:

- 11/1 Concrete:- FIST BTR
- 11/2 Concrete:- PANDROL
- 11/3 Steel:- E-3277
- 11/4 Wood:- E-3131

- 12 Method of stacking wood sleepers
- 13 Unloading concrete sleepers

RAILS**Rail profiles and properties**

- 14/1 Profiles:- 30kg, 40kg, 43kg, 48kg, 51kg
 14/2 Profiles:- 57kg, 60kg, S-49, UIC-60
 14/3 Profiles:- Zu-1-60, Z-S60-SAR, Zu-2-49, S-60-SAR
 14/4 Properties

Rail classification

- 15/1 Wear gauge
 15/2 Classification table
 15/3 Cutting of released rails

Temperature aspects

- 16/1 Expansion gaps for different rail lengths and temperatures
 16/2 Sections with moderate ruling temperatures
 16/3 Destressing and working temperature ranges
 16/4 Destressing and working temperature ranges
 16/5 Destressing and working temperature ranges

Defects

- 17/1 Typical rail defects and fractures
 17/2 Typical rail defects and fractures
 17/3 Transverse fissures (G4)
 17/4 Rail defects and fractures:- safety precautions to be observed.
 17/5 Rails with ultrasonic detected defects.

Cutting and joints

- 18/1 Minimum cut distance from welded joints and minimum distances between joints
 19 Drilling rails for metric P & M lubricators
 20 Jumpering when traction rail is replaced

SETS**Typical turnouts**

- 21/1 Sets of points
 21/2 Crossings
 21/3 Crossings with movable v-pieces

Layout of turnouts

- 22/1 Semi-curved hinged points blades
 22/2 Fully curved flexible points blades
 22/3 Trailable self-normalising points blades
 22/4 Fully curved flexible points blades:- cast manganese frogs
 22/5 do :- railbound frogs
 22/6 do. :- composite points blades and railbound frogs
 22/7 do. :- movable v-pieces with back sliding joints

Dimensions of turnouts

- 23/1 48kg : 1 067mm track gauge
 23/2 48/51kg : 1 065mm track gauge
 23/3 57/60kg : 1 065mm track gauge
 23/4 30kg : 610mm track gauge
 23/5 S60/ZS60 : 1 065mm track gauge

23/6	GERMAN UIC60	: 1 065mm track gauge
23/7	48/51kg	: 1 065mm track gauge: concrete sleepers
23/8	UIC60	: 1065mm track gauge: concrete sleepers

24 Radii of turnouts from curved track

Slips and crossings:- layout and dimensions

25/1	Diamond crossings:-	1:4½, 1:6, 1:7 and 1:8
25/2	Double slips	
25/3	Single slips	
25/4	Double slips (VAE)	

Insulating joints' positions

26/1	Turnouts and diamond crossings
26/2	Single and double slips

Tumblers

27/1	Lockable knuckle-jointed arm
27/2	Stiff counter-weight arm
27/3	Countersunk - for paved areas
27/4	Spring loaded linking mechanism

28 Cushion stop block

29 Fencing

Sleeper details

30/1	General
30/2	48kg 1:12 concrete sleepers
30/3	48kg 1:12 concrete sleepers
30/4	S60/UIC60 1:12 concrete sleepers
30/5	S60/UIC60 1:12 concrete sleepers
30/6	S60/UIC60 1:20 concrete sleepers
30/7	S60/UIC60 1:20 concrete sleepers

CHAPTER 1

THE PURPOSE OF THIS MANUAL, IT'S APPLICATION AND ASSOCIATED PUBLICATIONS TO BE READ IN CONJUNCTION HEREWITH

1.0 PURPOSE OF THE MANUAL

This manual describes the responsibilities of all track maintenance personnel and is issued for their guidance. It supersedes the Permanent Way Instructions issued in 1984.

1.1 APPLICATION OF THE MANUAL

1.1.1 Track personnel who are supplied with copies of this manual must acquaint themselves with it and act in accordance with the manual in so far as it concerns them. They must ensure that their copy is updated with any amendments that may be issued from time to time.

1.1.2 Except where provision is made for the contrary, this manual must be read in conjunction with, and not in lieu of the publications listed in **clause 1.2**. The term "Heavy haul lines" refer to S-lines (See Annexure 3 Sheet 1).

1.2 ASSOCIATED PUBLICATIONS

Track personnel must be in possession of the publications listed hereunder (together with any amendments which may be issued), have knowledge of their contents and act in accordance therewith.

- Manual for Track Maintenance
- Train Working Rules
- General Appendix (parts I and II)/General Train Working Rules
- Construction Standards for Private Sidings (part B)
- Track data and curve lists
- Lists of structures, bridges and culverts, tunnels, level crossings and fouling points in relation to Track Structure gauge
- Safety Guidelines for Infrastructure
- Electrical Safety Instructions
- Latest updated section 53 'Perway Material/Price list'
- Applicable operating notices
- Manual for Managing Track Material, Tools and Equipment
- Applicable work codes and decision models/guidelines.
- Protection Manual
- Work Code for Fire Prevention
- Manual for Contingency Plan for Accidents/Derailments.
- Quick Reference for Building of Turnouts.
- Signing of Railway Crossings, chapter 7, SARTSM, Vol2
- Work Code for the Maintenance of Block joints.
- Specification for Track Welding.

CHAPTER 2

THE GOAL AND PERFORMANCE OBJECTIVES FOR TRACK MAINTENANCE. SPECIFIC AND GENERAL RESPONSIBILITIES OF MAINTENANCE PERSONNEL WITH RESPECT TO THE TRACK INFRASTRUCTURE

2.0 THE GOAL FOR TRACK MAINTENANCE

The goal for track maintenance is to strive for the most economical but safe balance between resource input, track condition and required levels of operational readiness.

2.1 THE PERFORMANCE OBJECTIVES FOR TRACK MAINTENANCE

2.1.1 Track personnel must ensure that railway lines and associated works are always maintained to a standard which is safe for the passage of trains.

2.1.2 Employees must always regard the safety of the public, goods in transit and the safety and health of other employees as the first consideration.

2.1.3 Employees must not expose themselves to danger and must prevent other employees from exposing themselves and others to danger.

2.1.4 Service level agreements between Infrastructure-Maintenance , Service Execution and Service Planning must be met.

2.1.5 To continually strive for improved productivity to ensure an effectively and efficiently maintained rail network.

2.1.6 All departments involved must work together so as to ensure the long term viability of the track infrastructure and associated works. Care must always be taken to ensure that over or under maintenance of the track structure does not take place.

2.1.7 Infrastructure-Maintenance teams must have regular communication with traffic controllers each day, in order to minimise delays to trains

2.2 RESPONSIBILITIES OF THE ASSISTANT GENERAL MANAGER (INFRASTRUCTURE-MAINTENANCE)

The Assistant General Manager (Infrastructure-Maintenance) is responsible for

2.2.1 the long term viability of the track infrastructure and associated works,

2.2.2 maintaining and expanding the pool of knowledge and expertise,

2.2.3 ensuring that personnel are competent to perform their duties,

2.2.4 formulating policy and initiating strategies to meet objectives and taking corrective action when required,

2.2.5 performing certain services in respect of training, research and development, material, on-track machines and structures and

2.2.6 ensuring that the requirements of applicable legislation are complied with.

2.3 RESPONSIBILITIES OF THE INFRASTRUCTURE MANAGER

The Infrastructure Manager is responsible for:

- 2.3.1 determining and negotiating for required resources,
- 2.3.2 improving productivity on an ongoing basis,
- 2.3.3 monitoring safety and the quality of service continually and for initiating corrective actions,
- 2.3.4 identifying and utilising excess capacity,
- 2.3.5 ensuring that contingency planning has been done and will function smoothly if required,
- 2.3.6 ensuring that Depot Engineers are competent to perform their duties and
- 2.3.7 ensuring that the requirements of applicable legislation are complied with.

2.4 RESPONSIBILITIES OF THE DEPOT ENGINEER

The Depot Engineer is responsible for

- 2.4.1 the safe passage of trains, the safety of the public as well as the safety and health of his personnel,
- 2.4.2 the quality of service and ensuring that all agreements in this regard are complied with,
- 2.4.3 the effective management of all maintenance activities and resources,
- 2.4.4 maintaining and operating reliable systems,
- 2.4.5 ensuring that adequate resources are available for all aspects of track maintenance including call-out and emergency procedures,
- 2.4.6 carrying out prescribed inspections,
- 2.4.7 ensuring that work is properly managed and undertaken in accordance with the relevant work codes and
- 2.4.8 ensuring that formal and on the job training takes place and that the requirements of applicable legislation are complied with.

2.5 RESPONSIBILITIES OF THE MAINTENANCE MANAGER (TRACK) AND THE TRACK INSPECTOR (MAINTENANCE MANAGEMENT)

The Maintenance Manager (Track) focuses on the planning of track maintenance and is responsible for:

- 2.5.1 the safe passage of trains, the safety of the public as well as the safety and health of his personnel,
- 2.5.2 the effective maintenance of the track and associated works on his section,
- 2.5.3 inspections and the use of approved systems to plan, schedule and control all work and

- 2.5.4 ensuring that the requirements of applicable legislation are complied with.
- 2.5.5 The Track Inspector (Maintenance Management) focuses on the planning of track maintenance work and is responsible for the above mentioned on specific sections allocated to him.

2.6 RESPONSIBILITIES OF TRACK PERSONNEL IN CHARGE OF HEAVY ON-TRACK MACHINES

The person in charge of the work site (Track master or Track inspector) is responsible for

- 2.6.1 the safe passage of trains, the safety of the public as well as the safety and health of his personnel at the work site,
- 2.6.2 ensuring that contractors comply with relevant safety measures and instruct their personnel accordingly,
- 2.6.3 ensuring that work codes are complied with,
- 2.6.4 ensuring that contract conditions are adhered to,
- 2.6.5 ensuring that resources are used efficiently,
- 2.6.6 ensuring that the quality of service is maintained and
- 2.6.7 that the requirements of applicable legislation are complied with.

2.7 RESPONSIBILITIES OF THE PRODUCTION MANAGER (TRACK)

The Production Manager (Track) is responsible for

- 2.7.1 the safe passage of trains, the safety of the public and for the safety and health of his personnel at work sites,
- 2.7.2 using approved systems to manage all his work,
- 2.7.3 the efficient use of resources and
- 2.7.4 ensuring that all completed work complies with accepted norms and standards.
- 2.7.5 ensuring that the personnel under his control receive the necessary practical training in the correct use of and the efficient handling of material, tools and equipment. He must ensure that they are developed, coached and that they acquire sound experience in all aspects of track maintenance work,
- 2.7.6 performing any other duties assigned to him and
- 2.7.7 ensuring that the requirements of applicable legislation are complied with.

2.8 RESPONSIBILITIES OF THE ENGINEERING TECHNICIAN

The Engineering Technician is responsible for

- 2.8.1 performing all the duties assigned to him from time to time,
- 2.8.2 assisting with the improvement of the tools for the management of track maintenance,
- 2.8.3 assisting the Track Inspectors (Maintenance Management) with the planning, scheduling and controlling processes of track maintenance,
- 2.8.4 assisting the Maintenance Manager (Track) with the collection and processing of data
- 2.8.5 assisting in the determination of the long-term resource requirements.

2.9 RESPONSIBILITIES OF THE TRACK MASTER

Within his work area the Track master is responsible for:

- 2.9.1 the safe passage of trains, the safety of the public and for the safety and health of his personnel at the work site,
- 2.9.2 performing repair work in accordance with specific procedures and standards,
- 2.9.3 communicating regularly each day with traffic controllers and his controlling office,
- 2.9.4 the efficient use of resources,
- 2.9.5 ensuring that the requirements of applicable legislation are complied with and
- 2.9.6 any additional duties assigned to him.

2.10 RESPONSIBILITIES OF THE TRACK WELDER

Within his work area the Track Welder is responsible for

- 2.10.1 the safe passage of trains, the safety of the public and for the safety and health of his personnel at the work site,
- 2.10.2 performing work in accordance with specific procedures and standards,
- 2.10.3 the efficient use of resources,
- 2.10.4 ensuring that the requirements of applicable legislation are complied with and
- 2.10.5 performing any other duties assigned to him.

2.11 RESPONSIBILITIES OF THE TECHNICAL SUPERVISOR (WELDING) AND TRACK INSPECTOR (PRODUCTION)

Within their work area the Technical Supervisor (Welding) and the Track Inspector (Production) focus on the execution of track maintenance work and are individually responsible for

- 2.11.1 the safe passage of trains, the safety of the public, and for the safety and health of their personnel at the work site,
- 2.11.2 using approved systems to manage all their work,
- 2.11.3 the efficient use of resources,
- 2.11.4 ensuring compliance with specific procedures and standards,
- 2.11.5 ensuring that material, tools and equipment are neatly kept and that the appropriate records are kept,
- 2.11.6 ensuring that the personnel under their control receive the necessary practical training in the correct use of and the efficient handling of material, tools and equipment and to help them in obtaining a comprehensive practical knowledge of track maintenance work.
- 2.11.7 ensuring that the requirements of applicable legislation are complied with.

2.12 RESPONSIBILITIES OF THE TRACK MANAGER AND THE TECHNICAL MANAGER (WELDING) IN THE CENTRAL OFFICE

The Track Manager and the Technical Manager (Welding) of the central office are responsible for

- 2.12.1 training, coaching and for transferring their knowledge and expertise to all involved in track maintenance work.
- 2.12.2 ensuring that formal and on the job training of personnel conforms to requirements and
- 2.12.3 ensuring that the requirements of applicable legislation are complied with.

2.13 GENERAL RESPONSIBILITIES OF INFRASTRUCTURE-MAINTENANCE PERSONNEL

2.13.1 Protection of trains and safeguarding of employees

- 2.13.1.1. Where protection of Infrastructure-Maintenance teams at work sites overlaps, all the parties involved must agree beforehand upon a Person in Control for the extended work site, who will be responsible for the protection arrangements in terms of the Protection Agreement. The supervisors involved must ensure that all personnel under their control are aware of the applicable protection arrangements at the extended work site.
- 2.13.1.2. Protection duties may only be undertaken by an employee who has been certified competent by an officially authorised competent person.
- 2.13.1.3. The names of employees competent to perform protection duties must be kept on record.

- 2.13.1.4. The Person in Control must ensure that work teams are adequately safeguarded. Special care must be taken when safeguarding work teams working in busy station yards, on curved tracks, in cuttings, on multiple tracks or where the view is restricted. Where work teams are working close to mechanised equipment, they must be warned of the approach of a train by means of a hooter, siren or other device, the sound of which must be audible above the noise of the machines.
- 2.13.1.5. When the track is not safe for the passage of trains the Person in Control must instruct the hand-signalman regarding the warning to be given to train drivers.
- 2.13.1.6. When the track is not safe for the passage of trains at normal speed, the Person in Control must instruct the hand-signalman regarding the warning to be given to train drivers.
- 2.13.1.7. In the event of maintenance work being done to or adjacent to the track and the safety of passing trains and/or personnel and equipment could be affected, the Person in Control must instruct the hand-signalman regarding the warning to be given to train drivers.
- 2.13.1.8. The Person in Control must show the hand-signalman where hand signals must be displayed and where detonators must be placed and he must ensure that the protection complies with the approved protection procedures.
- 2.13.1.9. When work on or adjacent to the track can affect the safety of trains, occupation of the track must be taken by the Track inspector or Track master.

2.13.2 Detonators

- 2.13.2.1 Under no circumstances may tests of detonators be arranged or undertaken by unauthorised persons.
- 2.13.2.2 In the event of a detonator failing to detonate when a rail vehicle moves over it at an estimated speed of 10 km/h or higher, a detailed report must be submitted to the Depot Engineer's office. This report must be submitted together with the defective detonator as well as the remaining detonators in the original container from which the defective one was taken.
- 2.13.2.3 Reports must include the type and estimated speed of the vehicle as well as track and weather conditions.
- 2.13.2.4 Where detonators are placed on the track, the person responsible must ensure that nobody comes within a 3m radius of the detonators.
- 2.13.2.5 Detonators may not be placed less than one metre from a block joint.

2.13.3 Safety precautions

- 2.13.3.1 Track personnel must take precautions to safeguard life and to protect property when working or handling equipment or material.
- 2.13.3.2 Track personnel are not allowed to have pets with them when they are on duty.
- 2.13.3.3 Highly visible clothing, reflective braces and/or other approved identification garments must be worn by patrolmen, hand-signalman, and all personnel that work alone on or alongside the track.

2.13.4 Safety precautions in stations and yards

2.13.4.1 On completion of the day's work, any tracks in a station or shunting yard which have not yet been filled in and the ballast levelled off or where released material has not yet been removed or where new material has been unloaded but not yet installed into the track, the Track master must advise the traffic controller or controlling office accordingly. In the interests of safety of yard officials and other employees, the Track master must, where required, provide white lights to indicate the obstruction.

2.13.4.2 When working at stations, crossing loops, inter sidings or private sidings, track teams must examine the points in the normal and reversed positions. The crossings, points locks and bridles must also be examined. After the examination has been completed, care must be taken that the points are locked in the normal position.

2.13.5 Call outs

The Track master is responsible for attending promptly to defects communicated to him for repair via the Infrastructure-Maintenance fault control system. These faults can be reported by train drivers, track, signal or electrification personnel, the train control centre/traffic controllers, contractors, public etc.

2.13.6 Breaking of the line

Before breaking a line for alterations or repairs, the Track master must have authorisation for occupation of the track and must consult with the traffic controller in charge at each end of the section affected, the official in charge of the station/yard or the traffic controller in the train control centre, as the case may be. All relevant safety precautions required must be observed.

2.13.7 Breaking of track circuits

2.13.7.1 On electrified sections and/or where there are track circuits, a line must not be broken for alterations or repairs unless an authorised representative of Electrical and/or Signals is present or has been consulted. See clause 13.5.4.

2.13.7.2 Any two rails of a line which are track-circuited must not be short circuited, i.e. connected with metal objects such as track gauges, steel tapes or slewing bars.

2.13.8 Accidents and obstructions

2.13.8.1 Any accidents, irregularities or defects observed (of the track, passing trains, the signalling equipment or overhead track equipment) which are likely to interfere with the safe running of trains, must be reported immediately to the train control centre/traffic controller. The train control centre/traffic controller must ensure that the defect is reported to the official fault control system of Infrastructure-Maintenance. The person on duty at the official fault control system of Infrastructure-Maintenance must ensure that the appropriate Infrastructure-Maintenance teams are called out for the maintenance work. If telephone communication fails, the arrival of the first train must be awaited and the problem reported to the driver. If a Track master/Track inspector/production manager (track) is present then such person must instruct the driver of the actions to be taken. The driver will decide on the best course of action if none of these persons are available. Everything possible must be done to stop trains where immediate danger exists.

- 2.13.8.2 Track gangs must proceed promptly to the scene of the accident or obstruction and take the following actions:
- 2.13.8.2.1 Provide protection in accordance with the Protection Manual irrespective of any protection measures which may have already been provided by others. This must be maintained until the work is completed or alternative arrangements are implemented by the Person in Control.
- 2.13.8.2.2 The Person in Control must ensure that correct protection is maintained until he is sure that the line can be re-opened to traffic.
- 2.13.8.2.3 All lines that are not safe for the passage of trains must be protected on those sides of the obstruction from where a train might be expected.
- 2.13.8.2.4 Track personnel may not interfere with, or give instructions or advice to a member of another department who is affording protection.
- 2.13.8.3 The primary object after an accident is to assist the injured and to get the train service back to normal as quickly as possible. Track personnel must assist wherever it may be necessary, in order to expedite repairs to the track so that normal working may be resumed as soon as possible. They are not to be used as a source of labour for other departments, especially if expeditious repairs to the track may be adversely affected.
- 2.13.8.4 The Track master must restore or assist in restoring normal working as soon as possible and report full particulars of the incident and of any additional assistance or material which may be required in order to re-open the line.
- 2.13.8.5 A **G140** form must be submitted after all accidents involving trains. A **T458** form must be submitted after any accident other than:
- a head-on, rear-end or side-on collision
 - an accident due to an obstruction
 - where a stopblock was hit or a train ran through a set's points or a wheel tyre/broken axle caused the accident
- and there is agreement, amongst all parties involved on site, that the track condition did not contribute to the cause of the accident. The exact cause of the accident must be determined on site, by consensus amongst all the parties involved. This information may not however be communicated to anybody outside Transnet.
- The most senior member of the track personnel present must ensure that the track measurements necessary to complete the **T458** form are taken before any work is done on the track. The form must be signed by every person who has a share in completing it.
- 2.13.8.6 When vehicles are to be re-railed by pulling or propelling, the Track master must take precautions to protect the track against avoidable damage.
- 2.13.8.7 When trucks conveying explosives or dangerous goods are involved in an accident, the Track master must not unload or interfere with these trucks except as instructed in writing by the responsible senior officer or his deputy. The responsible senior officer must decide as to the best and most effective action to be taken in accordance with instructions relating to the safe handling of explosive materials involved in accidents.

2.13.8.8 Once damage to the track is repaired and it is safe for the passage of trains (at normal or restricted speed), the person in control of repair work (Track master, Track inspector or Production Manager) must advise the traffic controller at one of the adjacent stations or, if applicable, the train control centre/traffic controller, accordingly.

2.13.8.9 Official inquiries into accidents must be conducted as set out in **Circular A.10-1**.

2.13.8.10 In the case of animals injured or killed by trains, the Track master must remove them from the track to a safe distance outside the structure gauge. If the owner(s) is/are known and reasonably available, he/they must be asked to take further responsibility and to remove the animal(s)/carcasses. In all other instances the personnel of Infrastructure-Maintenance must take care and dispose of the animal(s) in accordance with locally prescribed procedures. Any maintenance work that might be required on the track must be done and the track certified safe for the passage of trains.

The Track master must complete and sign form T502/SPOORNET410 and forward it to the Depot Engineer's office. This form must be completed only insofar as the apparent or known information is on hand at the place where the incident occurred and at the time of clearing the track.

Other Infrastructure-Maintenance work required at or in the vicinity where the incident occurred, e.g. repairs to fences, must be reported immediately to Infrastructure fault control.

Infrastructure fault control will arrange for all further maintenance work to be undertaken and for any subsequent investigations, administrative matters or claims procedures which may be required. The Track master shall, if called upon to do so, pass on any helpful information to these parties.

2.13.9 Reporting of track defects

2.13.9.1 Track defects that may affect the safe running of trains, must be reported immediately to the train control centre/traffic controller as well as through the official fault control system of Infrastructure-Maintenance. Everything possible must be done to stop trains where immediate danger exists.

2.13.9.2 Track defects which do not affect the immediate safe running of trains, but which if left unattended could further deteriorate and present a danger to rail traffic over the short or medium term, must be reported to the Depot Engineer's organisation for purposes of planning of maintenance.

2.13.9.3 The person on duty at the fault control system of Infrastructure-Maintenance will ensure that Infrastructure-Maintenance personnel are contacted to undertake maintenance action.

2.13.9.4 The Track master must, at least three times every day (before starting work, at approximately midday and 15h00) establish if any track defects have been reported at the infrastructure fault control system. As soon as defects have been repaired, the Track master must notify the relevant party and advise him of the exact kilometre point where the defect was repaired as well as the nature of the repair work and the time it was done as well as further actions required.

- 2.13.9.5 Any deviation from **clauses 2.13.9.1 to 2.13.9.4** must be recorded in **Chapter 20**.
- 2.13.10 Goods found next to the track
- 2.13.10.1. Any luggage, goods or equipment observed on Transnet property must be reported to the nearest Client Service Centre who will arrange for the articles to be picked up. Details of time and place where luggage or goods were observed must be given.
- 2.13.10.2. When approaching or handling any luggage, goods or equipment found on Transnet property, the instructions set out in the Hazardous Materials Handbooks, must be observed and applied. See also Clause 2.13.15..
- 2.13.10.3. When approaching or handling asbestos found on Transnet property the instructions as outlined in the Spornet Procedure for Handling of Asbestos, must be adhered to.
- 2.13.11 Taking over a length
- 2.13.11.1 When a Track inspector or a Track master takes over a section, he should be shown over the length by his predecessor.
- 2.13.11.2 Places requiring attention must be pointed out and details of the current programme of maintenance work must be given.
- 2.13.11.3 The Track inspector or Track master must systematically examine every feature of the track so that he may become familiar with the types, quantities and condition of the track materials and with the types and condition of bridges and culverts and other structures. He must acquaint himself with the physical features of his section.
- 2.13.11.4 He must check the stock of track material, tools and equipment. Any shortages must be reported to the controlling office.
- 2.13.12 Possession of a reliable watch
- The Track master and the Track inspector must be in possession of reliable watches and must periodically check that their watches show the correct time.
- 2.13.13 Communication means
- The Track master and the Track inspector must be in possession of effective communication means for contacting the train control centre/traffic controller and their controlling office. Cellphone charges are expensive and discretion must be exercised when making calls.
- 2.13.14 Absence from section
- Before leaving his place of residence outside working hours, the standby Track master/Track inspector must advise his controlling officer, who will then be responsible for making the necessary relief arrangements.
- 2.13.15 Dangerous substances
- 2.13.15.1 Dangerous substances being transported are identified by a sign in the form of a diamond. The colour of the sign indicates the substance and action(s) to be taken in case of an emergency:
- 2.13.15.2 Orange indicates explosives and that the area must be evacuated to a safe distance.

- 2.13.15.3 Green indicates compressed gas and that the area must be evacuated to a safe distance and that confined spaces are to be avoided.
- 2.13.15.4 Red indicates flammable substances and that evacuation to at least a distance of 500m is required if burning should occur.
- 2.13.15.5 White indicates poison and that contact must be avoided and that the gas must not be inhaled.
- 2.13.15.6 Black and white indicates corrosive substances and that contact must be avoided.
- 2.13.15.7 Blue indicates that the substance is dangerous when wet, is flammable and must be stayed clear of.
- 2.13.15.8 Yellow indicates oxidisers which may be flammable and must be avoided.
- 2.13.15.9 Yellow and white indicates that the substance is radio active and that no persons must come within 40m of the substance.

CHAPTER 3

EARTHWORKS, THE FORMATION, DRAINAGE, TUNNELS, BRIDGES, CULVERTS AND TEMPORARY TRACK SUPPORTS

3.0 INSPECTION

The inspection of earthworks, the formation, drainage, tunnels, bridges and culverts as well as temporary track supports must be carried out as set out in **clauses 4.0.5** and **4.0.6**.

3.1 EARTHWORKS

- 3.1.1 Banks and cuttings must be observed for cracks, landslides and rock falls.
- 3.1.2 Excavations must be carried out to safe batters. Shoring must be provided if it is impractical to work to safe batters. Shoring must always be provided in trenches and similar restricted excavations where the depth exceeds 1,5m, except when the presence of homogeneous solid rock causes the excavations to be absolutely safe without shoring.
- 3.1.3 Where excavations are carried out in soft material and the vibration of passing trains may cause caving in of earth, safety precautions must be taken and a temporary speed restriction imposed if necessary.
- 3.1.4 The formation must be maintained at the width and shape shown in **Annexure 4**.
- 3.1.5 When embankments are being constructed, material must not foul the structure gauge or obstruct the drainage.
- 3.1.6 Material to be used and the method of compacting must be approved by the Depot Engineer.
- 3.1.7 Borrow pits must be made on the lower side of the track if practical. The top of the borrow pit must be at least 3m from the toe of an embankment or from the boundary line, and the borrow pit wall must have a batter. Borrow pits must be drained and fenced if necessary.

3.2 THE FORMATION

- 3.2.1 A dry formation is a pre-requisite for a stable track structure.
- 3.2.2 Storm and ground water must be quickly and effectively drained away from the formation.
- 3.2.3 Competent guidance is required when repairs to the formation are undertaken.

3.3 DRAINAGE

- 3.3.1 All drains must be kept clean to allow water to flow freely.
- 3.3.2 Vegetation must not be removed from drains on steep inclines unless precautions are taken to prevent erosion.
- 3.3.3 Steps provided on slopes of banks and cuttings to gain access to the formation must not interfere with drainage.

- 3.3.4 Drains and catchwater mounds must be built to divert stormwater where necessary. The Depot Engineer must give his approval before work is started.
- 3.3.5 The top edge of a catchwater drain or the toe of a catchwater mound must, if possible, be at least 3m from the boundary of the right of way.
- 3.3.6 Material excavated from catchwater drains must be deposited on the low side of drains to increase the effective depth of the drains.
- 3.3.7 The Depot Engineer must be advised if Transnet property might be affected where:
 - 3.3.7.1 storm-water from adjoining land has been diverted from its natural course
 - 3.3.7.2 new drains are being constructed
 - 3.3.7.3 dams are being constructed that could cause erosion or flooding
 - 3.3.7.4 soil erosion is taking place on adjoining land
 - 3.3.7.5 stormwater run-off is increasing.

3.4 TUNNELS

- 3.4.1 When working in tunnels particular care must be taken, because of the dangers involved, to adequately safeguard all personnel. Adequate lighting is essential.
- 3.4.2 Interiors of refuges and a 1m surround must be painted white.
- 3.4.3 Attention must be given to the drainage of tunnels and approach cuttings. Any obstruction in the drains must be removed.
- 3.4.4 In tunnels with ballasted track, reference pegs must be inserted at 20m intervals in both walls, so that a line which is stretched over the tops of the pegs will touch both rails when the track is at the correct level and cant. A list of offsets from the ends of the pegs to the track centre line must be supplied. The track must be lifted and aligned in accordance with these reference marks.
- 3.4.5 In the case of tunnels longer than 1000m, the letter 'P' must be painted with white paint on a black background at both tunnel portals. This must be clearly visible to indicate that protection may be encountered within that tunnel at the protection distance. These letters must be 600mm high by 400mm wide, positioned at a height of 2500mm above rail level.

3.5 BRIDGES AND CULVERTS

- 3.5.1 Track personnel must look out for the following defects:
 - 3.5.1.1 Scour under piers or abutments and at inlets and outlets of culverts.
 - 3.5.1.2 Structural damage, cracks, loose rivets or bolts, corrosion and movement of bedplates.
 - 3.5.1.3 Loose or ineffective handrails and/or walkways and where bridge or culvert openings are inadequate.
- 3.5.2 See **clauses 6.6.2** and **6.8.3** for laying of rails on unballasted bridges.

- 3.5.3 Safety rails, shown in **Annexure 6**, must be provided on unballasted bridges longer than 10m. In other cases the Depot Engineer will decide whether they are necessary. Each safety rail must be fastened by two coach screws to every sleeper.
- 3.5.4 Only approved sleepers may be used on unballasted bridges. Sleeper spacing may not be more than 610mm.
- 3.5.5 The distance between the centre lines of the sleepers behind and in front of ballast walls must not be more than 700mm. Cases where this is not possible must be reported to the Depot Engineer. He will arrange for the rails to be supported directly on the ballast walls, in accordance with **drawing BE 75-22**.
- 3.5.6 The Depot Engineer must be advised where it is necessary to adjust cant or to eliminate camber on bridges. Loose plates or tapered sleepers must not be used, nor may the track be raised by placing sleepers on top of one another.
- 3.5.7 Fastening of sleepers on bridges must be in accordance with **Annexure 8**.
- 3.5.8 Parapets, ballast walls, copings and handrails on bridges and culverts, in areas where shunting is done, must be painted white.
- 3.5.9 Competent guidance is required when steelwork is repaired and painted.
- 3.5.10 Culvert entrances and outlets must be cleaned annually before the onset of summer rains (or winter rains in the Western Cape) of all shrubs, bushes and trees to allow for an unrestricted flow of water through the culvert opening.
- 3.5.11 When constructing a maintenance road through a culvert opening it must be done in such a manner so as not to restrict the flow of water during sudden down pours.

3.6 TEMPORARY TRACK SUPPORTS

- 3.6.1 Should a line require temporary support, this can be provided by sleeper cribs, steel bridging cribs, trestles or rail girders. Details are shown in **Annexure 7**.
- 3.6.2 A speed restriction of 15 km/h must be imposed on a track with temporary supports.
- 3.6.3 Temporary track supports must be inspected at frequent intervals. All fastenings must be kept tight.
- 3.6.4 Rail girders
 - 3.6.4.1 The track must be fitted with wood sleepers, placed at 600mm centres.
 - 3.6.4.2 Top-rail girders are used principally when excavations are to be made under open lines. Bolts and rail girder clamps must not project above the top of the running rails. Girders must be laid on sleeper cribs.
 - 3.6.4.3 Bottom-rail girders are principally used in emergencies. They are built on top of sleeper or bridging cribs and provide a working platform on which a new track can be built.

3.6.5 Cribs

- 3.6.5.1 All sleepers must be sound, square and straight. Wood wedges must be used to eliminate any movement. Wedges must be anchored.
- 3.6.5.2 The bottom layer of sleepers in cribs must be close-laid and parallel to the track centre line.
- 3.6.5.3 Rails used with double stack cribs must have the same height (size) and must be sound and free of defects.

CHAPTER 4

INSPECTIONS AND TRACK GEOMETRY

4.0.0 Inspections general

Inspections of the track and associated infrastructure are used as a safety measure and also to determine the annual and long term work load.

The responsibilities of individual track maintenance personnel are to ensure that:

- inspections are carried out by competent personnel, at the required frequencies, and in accordance with the available work codes.
- written inspection reports are prepared and systems are used to ensure action is taken and appropriate records are kept. It must be seen against the specific and general responsibilities described in chapter 2 and elsewhere in this manual.

4.0.1 Patrolling

4.0.1.1 Each depot's patrolling process must be submitted to and approved by the Infrastructure Manager and recorded in **chapter 20**.

4.0.1.2 The Track Inspector (Maintenance Management) must ensure that the approved process of patrolling and defect reporting is carried out.

4.0.1.3 If a track defect or damage to the track which may affect the safety of trains is observed, patrolling must be abandoned and protection afforded according to laid down instructions, first on the side from which the first train is expected and then on the other side. The defect/damage must be reported in accordance with clause 2.13.8. and 2.13.9..

4.0.1.4 In addition to telephonically reporting defects or damage in accordance with **clause 4.0.1.3**, a report must be submitted to the Depot Engineer's organisation, recording information gathered for each day on which patrolling was done. This report must be used as an input for planning track maintenance work.

4.0.1.5 During stormy weather, special patrols must be carried out to ensure that the track, earthworks, formation, drainage and associated structures remain safe for the passage of trains. The maximum flood water level must be recorded (on both sides of the track) during wash aways.

4.0.2 Trolley Inspections

4.0.2.1. During trolley inspections individual responsibilities must be focused on, as set out in **Chapter 2**.

4.0.2.2. The Assistant General Manager (Infrastructure-Maintenance) must inspect S and N1 lines annually, N2-lines every second year and N3-lines once every 3 years.

4.0.2.3. The Infrastructure Manager must inspect S and N1-lines twice a year, N2 lines once a year and N3-lines every second year.

4.0.2.4. The Chief Engineer (Permanent Way Infrastructure) of Metro should be allowed to annually inspect Spoornet lines that carry SARCC traffic.

- 4.0.2.5. The Depot Engineer must inspect S and N1 lines every month, N2 lines every second month and N3 lines once every four months. Fifty percent of these inspections may be delegated to the Maintenance Manager(Track).
- 4.0.2.6. The Track Inspector (Maintenance Management) must inspect S, and N1 lines every week, N2 and SARCC trafficked lines every second week and N3 lines once per month.
- 4.0.2.7. Trolley inspections must be pre-planned on an annual basis.
- 4.0.2.8. Inspections should be carried out at the probable speed of a typical train traversing the section.
- 4.0.2.9. Footplate inspections may be substituted for trolley inspections.
- 4.0.2.10. Deviations from the above must be approved by the Infrastructure Manager, and the method(s) adopted and inspection frequencies must be recorded in chapter 20
- 4.0.2.11. Track personnel must also be encouraged to take part in trolley inspections at other depots as the process will speed up training and the transfer of skills.
- 4.0.3 Footplate inspections
- 4.0.3.1 Attention must be afforded to those aspects that will not emerge from other inspections.
- 4.0.3.2 The Depot Engineer and Maintenance Manager must respectively inspect all lines twice and four times annually with at least one inspection being undertaken during night time. Half of these inspections may be delegated.
- 4.0.3.3 The inspection trip should be undertaken on a train representing the most common train running on that section.
- 4.0.3.4 The driver should be requested to indicate over which sections he usually reduces speed due to poor track conditions. On such sections the reaction of the locomotive must be afforded special attention.
- 4.0.3.5 The driver's special knowledge of track conditions must be fully utilised.
- 4.0.3.6 Deviations from the above must be approved by the Infrastructure Manager and must be recorded in **chapter 20**.
- 4.0.4 Inspections by the track measuring car
- 4.0.4.1 The track measuring car is used to measure the geometric condition of the track.
- 4.0.4.2 These track measurements must be used to ensure compliance with responsibilities as set out in **clause 4.0.0** and **chapter 2**.
- 4.0.4.3 The Track Inspector (Maintenance Management) must accompany the car, take note of defects and if necessary initiate urgent repairs.
- 4.0.4.4 The responsible Engineer or Engineering Technician must accompany the car to ensure that contract conditions are met.

- 4.0.4.5 Measuring frequencies will be determined by the Assistant General Manager (Infrastructure-Maintenance). Deviation from the frequencies must be approved by the Infrastructure Manager and recorded in **chapter 20**.
- 4.0.5 Inspection of structures
- 4.0.5.1 Bridges, culverts and lined tunnels must be inspected at least once per year. Unlined tunnels must be inspected monthly by the Track Inspector (Maintenance Management).
- 4.0.5.2 Coal stages, turn tables, pits, retaining walls and water towers must be inspected annually.
- 4.0.5.3 See **clause 3.6** re temporary track supports.
- 4.0.6 Inspection of earthworks, the formation and drainage
- Earthworks, the formation and drainage must be inspected at least once per year.
- 4.0.7 Ultrasonic and x-ray inspections
- The frequency of inspections is determined by the Depot Engineer, in consultation with the Assistant General Manager (Infrastructure-Maintenance). Deviation from the work code must be approved by the Infrastructure Manager. Measurement frequencies and deviations must be recorded in **chapter 20**.
- 4.0.8 Inspection of track material
- 4.0.8.1 Track material is inspected annually by the Depot Engineer's organisation.
- 4.0.8.2 Inspections must be carried out in accordance with the latest work code.
- 4.0.8.3 Deviations from the work code or inspection frequency must be approved by the Infrastructure Manager, and recorded in **chapter 20**.
- 4.0.9 Inspection of turnouts, slips and diamond crossings ('sets')
- 4.0.9.1 These inspections are the responsibility of the Track Inspector (Maintenance Management).
- 4.0.9.2 Sets on S and N1 lines must be inspected at least once a month. The frequency of inspections on N2 lines, N3 lines and in yards must respectively not exceed 2,4 and 6 months.
- 4.0.9.3 Deviations from the work code or inspection frequency must be approved by the Infrastructure Manager, and recorded in **chapter 20**.
- 4.0.10 Inspection of signs, level crossings and fences
- 4.0.10.1 Three monthly inspections of road and track signs, level crossings and fences is the responsibility of the Track Inspector (Maintenance Management).
- 4.0.10.2 In addition, the items mentioned in clause 4.0.10.1 should be regularly observed by track personnel that work in the area in order to arrange for urgent repairs to be undertaken.
- 4.0.10.3 Deviations from the work code or inspection frequency must be approved by the Infrastructure Manager, and recorded in **chapter 20**.

4.0.11 Inspection of clearances

- 4.0.11.1 The Depot Engineer must ensure that annual inspections are carried out and that the conditions set out in **chapter 8** are complied with.
- 4.0.11.2 Deviations from the work code or inspection frequency must be approved by the Infrastructure Manager, and recorded in **chapter 20**.

4.1 TRACK GEOMETRY

4.1.1 Standards

- 4.1.1.1 The geometric condition of the track has an important influence on the life cycle of the track structure and the cost of track maintenance.

- 4.1.1.2 As a result of this influence on costs and the relative ease with which geometry can be measured, general standards have been developed to assist in the process of defining work priorities.

4.1.1.3 The general standards

- 4.1.1.3.1 When track work is done, the work must conform to the A-standard.
- 4.1.1.3.2 Repair work must be considered when the B-standard is reached.
- 4.1.1.3.3 On S lines work must be done before the C-standard is reached.
- 4.1.1.3.4 On N1 lines work should preferably be done before the C-standard is reached.
- 4.1.1.3.5 On N2 lines urgent inspection of track below the C-standard is required; and
- 4.1.1.3.6 On N3 lines track below the C-standard must be inspected regularly.
- 4.1.1.3.7 When the C-standard is exceeded, repair work must be given a higher priority

4.1.1.4 Numerical values for geometric parameters:

The standards show permissible deviation from design values, except for twist, which are absolute values.

4.1.1.4.1 Horizontal alignment on straight track:-

- A :- 1:2000
B :- 1:500 and
C :- 1:360.

4.1.1.4.2 Horizontal alignment, on curves and on transition curves:-

- A :- $(5\% \times H) + 2.5\text{mm}$
B :- $(20\% \times H) + 2.5\text{mm}$
C :- $(30\% \times H) + 2.5\text{mm}$
H being the mid-ordinate, in millimetres, measured with a 10m cord.

4.1.1.4.3 Vertical alignment:-

- A :- 1:1000
B :- 1:250 and
C :- 1:180.

4.1.1.4.4 For twist the standards are:

Straights and circular curves

A :- 1:1000
B :- 1:400 and
C :- 1:288.

Transition curves

A :- 1:500
B :- 1:400
C :- 1:288

4.1.1.5 For specific application of these standards reference must be made to the work code for geometric track evaluation.

4.1.1.6 Deviations **from clauses 4.1.1.1 to 4.1.1.3** must be approved by the Depot Engineer and recorded in **chapter 20**.

4.1.2 Transition curves

4.1.2.1 A transition curve is a curve of varying radius such that the centrifugal force generated on the track by a train travelling at a constant speed, increases uniformly from the end of the tangent track to the beginning of the circular portion of the curve.

4.1.2.2 On running lines the most appropriate transition curve lengths are 60m for curves sharper than 300m and 80m for curves flatter than 300m.

4.1.3 Gauge

4.1.3.1 On straight track the gauge for broad gauge track is 1 065mm and 610mm for narrow gauge track.

4.1.3.2 The gauge for track on curves and the maximum permissible gauge due to wear, is

Standard gauge track (1 065 mm gauge)

Radius (m)	Without check rails Gauge (mm)	
	Normal	Maximum
< 135	1 085	1 105
135 – 150	1 080	1 105
151 – 175	1 075	1 100
176 – 200	1 070	1 095
> 200, tangent track	1 065	1 090
With check rails Gauge(mm)		
< 135	1 090	1 105
135 – 150	1 085	1 105

Narrow gauge track (610mm gauge)

Radius (m)	Without check rails Gauge (mm)	
	Normal	Maximum
< 200	620	630
200 – 300	615	625
> 300, tangent track	610	620

- 4.1.3.3 Steel and wood sleeper fastenings, with clips and bolts, are designed to allow gauge adjustments in steps of 5mm. The gauge can vary from 1 065mm to 1 090mm with new rails.
- 4.1.3.4 Gauge widening must take place in accordance with **Annexure 9, sheets 2 and 3**.
- 4.1.3.5 When laying track with wood sleepers, the initial gauging should provide widening at a uniform rate.
- 4.1.3.6 Where rails are laid on wood sleepers with sole plates, or cast iron chairs with keys, re-gauging must not be resorted to. The high leg rails must be renewed before the maximum permissible track gauge has been reached.
- 4.1.3.7 Where rails are held with clips, re-gauging by changing the clip combination must be undertaken if the limit of gauge is reached before the limit of rail wear. Refer to **Annexure 11 and clause 17.1.4**.
- 4.1.3.8 Any deviations from these standards must be documented, approved by the Infrastructure Manager and included in chapter 20 of this manual.
- 4.1.4 Cant
- 4.1.4.1 Cant must be provided in accordance with **Annexure 9, sheet 4**. When temporary speed restrictions are introduced on curves, cant must also be adjusted according to Annexure 9, sheet 4. Where a temporary speed restriction of 15km/h is applied, half of the cant as for 30km/h must be applied. See also clause 13.4.2 for electrified lines.
- 4.1.4.2 The cant of curves in yard tracks must not exceed 10mm.
- 4.1.4.3 On curves without transitioned ends, two-thirds of the full cant must be applied at the beginning and end of the curve. The cant must be increased to the full amount towards the middle of the curve and decreased to zero into the straight at a rate not exceeding 10mm in 5m (i.e. 1:500, the maximum permissible twist in transitions).
- 4.1.4.4 On curves with transitioned ends, application of cant must commence at the point where the transition curve joins the straight. Cant must be uniformly applied over the transition to reach the required value at the point where the transition curve joins the circular curve. Should this not be possible without exceeding the rate of 10mm in 5m, cant must be uniformly applied at the maximum rate over the transition and into the circular curve.
- 4.1.4.5 On reverse curves where the intervening straight is less than 40m, both rails of the track must be at the same level for a distance of 6m between the two curves.
- 4.1.4.6 At or near mainline points and crossings and wherever the rate of wear on rails indicates that it is advisable, the specified cant may, on the authority of the Depot Engineer, be increased or decreased by up to 20mm for 1 065mm and 10mm for 610mm gauge lines.
- 4.1.4.7 When a turnout is situated on a curve, no cant is to be provided over the turnout but a permanent speed restriction of 30 km/h must be imposed.

CHAPTER 5

SETS (TURNOUTS, SLIPS AND DIAMOND CROSSINGS)

5.0 **INTRODUCTION**

- 5.0.1 Turnouts, slips and diamond crossings (collectively called 'sets') are expensive to replace, costly to maintain and are weak links in the track structure.
- 5.0.2 Unused sets must be removed in collaboration with relevant parties following the prescribed process.
- 5.0.3 Before sets are replaced, Operating, Electrical and Signals should be consulted to establish whether the layout can be simplified.
- 5.0.4 Sets must preferably be pre-assembled in a workshop according to the latest Quick Reference for Building of Turnouts. The process must be guided by competent track personnel.
- 5.0.5 Sets must be built, inspected, evaluated and maintained in accordance with the latest work codes. Before a set is put into the track it must be checked in every detail by the Track inspector, to ensure that it is correctly built.
- 5.0.6 Maximum allowable speed over and speed restrictions applicable to sets are prescribed in the General Appendix/General Train Working Rules.

5.1 **GENERAL**

- 5.1.1 If unavoidable, one exothermic joint or one flash-butt welded joint is permitted in lead and closure rails, provided the joint positions comply with **Annexure 18 sheet 1**.
- 5.1.2 Turnouts of 1:6 angle to **drawings E7051, E7075 and E7078** must be built only as equal-split turnouts.
- 5.1.3 On split 1:12 and 1:9 turnouts (i.e. through line is not straight), 5m and 4,88m guard rails respectively, must be used on both legs of the turnouts.
- 5.1.4 Where the guard rail projects beyond the end of the guard stock rail, and there is insufficient clearance for the inner 100% fishplate at the stock rail's joint, a flat or angle fishplate must be paired with the outer 100% fishplate.
- 5.1.5 The alteration of stock rails and points blades from one hand to the other by bending or straightening the stock rail at the vertex is only allowed as follows:

<u>Location</u>	<u>Rail weight</u>	<u>Type of set</u>
Yards and Sidings only	30 kg/m and 40 kg/m	1:8 to 1:12
All lines	30-kg/m and 40-kg/m	1:5 to 1:7
All lines	22-kg/m	All

- 5.1.6 Gauge for sets must be in accordance with the work code for the building of turnouts, slips and diamond crossings.

- 5.1.7 Where turnouts are on curves, the gauge must be adjusted (forward from the extreme end of the guard rail and backward from the stock rail joint of the turnout), by 5mm every 6 sleepers, until it matches the gauge of the curve.
- 5.1.8 The gauge at the obtuse crossing of diamond crossings must be checked at least every six months, and if less than 1 065mm or more than 1 075mm, must be adjusted to 1070mm.
- 5.1.9 Working parts must move freely, fit correctly and be kept clear of obstructions. Nuts and bolts securing components must be kept tight. Broken bolts must be replaced.
- 5.1.10 Whenever any component of a turnout is replaced, the mismatch of the rail running surfaces must be rectified by welding and/or grinding without delay.
- 5.1.11 Welding and grinding must be performed in accordance with the latest work code.
- 5.1.12 Heel and crossing bolts must be greased over their full length to prevent rusting.

5.2 MAINTENANCE OF STOCK AND POINTS RAILS

5.2.1 General

- 5.2.1.1. To reduce the wear on switch blades, switch lubricators must be installed. Alternatively lubrication may be affected by applying grease or graphite by hand.
- 5.2.1.2. Bolts and/or cotter pins holding stock rails to chairs must be securely in position.
- 5.2.1.3. Heel bolts must be tightened to prevent undue movement, but without interrupting the easy operation of the points blade. Ferrules must be in position and replaced when worn.
- 5.2.1.4. Points blades must fit the stock rail closely and accurately with full bearing against the head.
- 5.2.1.5. Points blades must rest on the slide chair. Should the points blade show a tendency to rise off the sliding surface, the cause must be ascertained and the fault rectified.
- 5.2.1.6. Burrs which interfere with the fit of switch blades against stock rails or with the operation of locking bars, must be removed by grinding. Burrs must further be kept in check in order to prevent breakouts on switch blades and stock rails. Grinding must be done in accordance with the Specification for Track Welding.
- 5.2.1.7. All points blades must be black-leaded over the first 1,25m. Slide chairs (except where teflon slide plates are fitted on concrete sleepers) must be cleaned and black-leaded. Lubricating oil may not be used.
- 5.2.1.8. Unusual wear of points blades must be reported to the controlling officer, in order to decide on protective measures.
- 5.2.1.9. Points blades must be renewed (with welding where permitted) before they become worn to an extent likely to affect safe working.

5.2.2 Hinged points blades

- 5.2.2.1 Hinged points blades must be replaced under the following conditions:
 - 5.2.2.1.1 Before 300mm of the points blade is worn to a knife edge.

- 5.2.2.1.2 Before wear creates a knife edge that is more than 15mm below the rail level of the stock rail at any position. (Measured with the points blade well seated on the slide chairs)
- 5.2.2.1.3 If chips occur that are more than 25mm long or 10mm below rail level of the stock rail (welding repairs can be done in the first metre of the points rail).
- 5.2.2.1.4 Before side-cutting occurs on the points stock rail.
- 5.2.2.1.5 If black spots appear on the head of the points blade, or shelling or mushrooming occurs.
- 5.2.2.2 Where heavy crown wear occurs on the stock rail and little or no wear on the corresponding points blade, the stock rail must be renewed with welding and/or grinding, where permitted. Alternatively, the points rail must be ground to fit, before the vertical gap between the running edge of the stock rail and the top of the points blade exceeds:
- 8mm in the area where crown wear is caused by hollow wheels' false flanges
 - 2mm at the machined end of the points blade.
- 5.2.2.3 Points blades and/or stock rails must be replaced (together, if a matching piece is not available) when the crown wear of either exceeds 10mm.
- 5.2.2.4 Points blade protectors (reversible web-mounted block or lead guard rail) may be used to limit wear of points blades in yards and running lines with low speeds.
- 5.2.3 Flexible type points blades and undercut stock rails
- Flexible type points blades and undercut stock rails must be replaced together under the following conditions:
- 5.2.3.1 Before wear creates a knife edge over a distance of:
- 1 000mm for 1:9 turnouts
 - 1 100mm for 1:12 turnouts
 - 1 300mm for 1:20 turnouts,
- measured from the tip of the points blade.
- 5.2.3.2 Before the top of the points blade, at any position further than 1 000mm from the tip, is worn more than 15mm below rail level of the stock rail (measured with the points blade well seated).
- 5.2.3.3 If chips occur that are more than 25mm long or 10mm below rail level of the stock rail.
- 5.2.3.4 Before side-cutting occurs on the points stock rail.
- 5.2.3.5 If black spots appear on the head of the points rail or shelling or mushrooming occurs.
- 5.2.3.6 If side-cutting occurs on the stock rail but not on the points blade. The points blade and stock rail must be replaced before the points blade chips or bends over.
- 5.2.3.7 Before the crown wear of the points blade or stock rail exceeds 10mm.

5.3 MAINTENANCE OF FROGS

5.3.1 Rail manufactured frogs

Frogs should be replaced when the top wear (of the point- or splice rail) measured from a straight edge placed across the wing rails one metre from the nose of the frog, reaches:

5.3.1.1 In running lines:- 5mm (for all rail sections).

The frogs' use may be extended by:

- welding and grinding of the frog and the throat-area of the wing rails
- grinding of the throat-area of the wing rails (to relieve wheel hammer).

The permissible wear may then be increased as indicated in **clause 5.3.1.3**.

5.3.1.2 In loops, sidings and yards the frogs may be allowed to wear until wheel flanges touch the bottom of the flangeway (spacer blocks). This should normally only occur when top (crown) wear exceeds that shown in clause 5.3.1.3.

5.3.1.3 Allowable crown wear of crossing frogs

Rail profile	Running lines	Loops, sidings, yards
≥48 kg	10mm	15mm
40kg	8mm	10mm
≤30kg	5mm	6mm

5.3.1.4 Guard stock rails must be replaced together with frogs if the components' sleeper spacing require it.

5.3.2 Cast 14% manganese frogs (Railbound and Monoblock)

5.3.2.1 Maintenance welding and grinding work must be performed in accordance with the Welding Specification sections SSS13 and SSS14 .

5.3.3 The wing rails of the movable V-type frogs are to be ground before the wear (measured as in clause 5.3.1) exceeds 3mm. The moveable V piece is to be replaced before the wear exceeds 10mm.

5.3.4 The overlap that forms on frogs must be removed by grinding before chips form in the overlap.

5.3.5 Components must be replaced before the maximum clearance between the guard rail and the guard stock rail opposite the frog is 50mm (57mm for old type 1:7 turnouts).

5.4 POINTS LOCKS AND KEYS

5.4.1. Where signalling gear is not installed, track personnel must replace defective points locks.

5.4.2. Provided the lock itself is sound, a key which cannot open a lock or which can be withdrawn from an open lock must be scrapped.

5.4.3. Defective locks and keys must be returned to the Depot Engineer's office for repair or replacement.

5.4.4. Missing points locks must be replaced and the circumstances reported to the officer in charge.

5.4.5. Points locks must be black-leaded internally.

5.4.6. Patrick locks are used in accordance with operating instructions at some sets, including those at fuel sidings.

5.5 BRIDLE-LOCKED POINTS

- 5.5.1 The amount of slack in bridles or bridle chains of locked tumbler levers must not exceed 15mm.
- 5.5.2 At interloops where there is no signalling, counter weight arms must be provided with two bridles, one on each side of the arm. The lock must be placed so that the tumbler may be locked when set for the main line.

5.6 POINTS BOXES

- 5.6.1 Fitting points boxes with retaining mechanisms (Racor, Henry Williams, or as shown in **Annexure 27 sheet 4**), will improve safety of train movements over sets.
- 5.6.2 On running lines, the counter weights or the indicator plates must be painted half white and half red. The white half must be uppermost when the points are set for the main line.
- 5.6.3 Counter weights of points boxes not on running lines must be painted white. If the points must be kept locked in a specific position, the centre recess on both sides of the counter weight must, on direction of the yard official in charge, be painted black.
- 5.6.4 The clearance of the counter weight arm to the track centre line is 2 000mm. Depending on track centres, a points box with arm working parallel to the track may be required.
- 5.6.5 The Track master must ensure that the throw of the stiff-arm type points box is equal for both settings of the points.
- 5.6.6 The pins of the levers must be lubricated when the turnouts are cleaned and lubricated.
- 5.6.7 Points box components must be renewed before they become so worn that either the tumbler is not easily thrown over, or the points remain partially open.
- 5.6.8 The Track master must ensure that switch blades lock properly, both in the turnout and mainline setting.
- 5.6.9 Where derailments tend to occur on sets in yards, the switch boxes must be replaced with a Tumbler (stokstyf) with spring loaded linking mechanism. Refer Annexure 27 sheet 4.

5.7 SPIKED POINTS

If it is necessary to restrict movements through a turnout to one track, the points blades must be set for that track and secured with an adjustable points clamp and private lock or with a fishplate and two 'A' coach screws. The train control centre/traffic controller must be notified accordingly.

CHAPTER 6

RAILS

6.0 THE TRANSPORT AND HANDLING OF RAILS

- 6.0.1 Rails must be handled with care.
- 6.0.2 Rails must be off-loaded as close as possible to the time that they are required, and exactly as planned. Special care must be taken to match adjoining rails when re-conditioned, re-profiled and second hand rails are offloaded.
- 6.0.3 Offloaded rails must be kept clear of the track, electrical and signal equipment and must not be covered with soil or ballast.
- 6.0.4 Rails must be offloaded clear of level crossings.

6.1 BENDING AND STRAIGHTENING OF RAILS

- 6.1.1 Because of the danger of fracture, rails must not be straightened or curved in cold weather.
- 6.1.2 Before rails are placed in the track, all kinks must be removed.
- 6.1.3 On all curves, rails must be uniformly curved to true radius, as follows:
- 6.1.3.1 All 36m and shorter rails, throughout their length.
- 6.1.3.2 Continuous welded rail:
- curve radius < 500m:- curved throughout their length.
 - curve radius ≥ 500m:- 10m at each end must be curved.
- 6.1.4 The correct size jim-crow must be used for the mass of rail concerned.
- 6.1.5 If a mechanical jim-crow is used, the last metre of the rail must be curved with a hand type jim-crow.
- 6.1.6 When a hand type jim-crow is used, it must be moved by approximately half its length at a time.

6.2 RAIL USAGE

- 6.2.1. Consideration must be given to transpose the high leg rail to the low leg rail in order to optimise the wear life of rails. Consideration should also be given to exchange the rails on tangent track with rails on curves. Refer decision models clause 16.3.8.
- 6.2.2. Only class C and better rails may be used.
- 6.2.3. When another type and/or class of rail other than that mentioned in **Annexure 3** is considered for use, it must comply with the requirements of an equivalent rail as indicated below and with **clause 10.3.1.1.3**.

RAIL TYPE AND CLASS	EQUIVALENT RAIL
---------------------	-----------------

60 New 60 Class A 60 Class B 60 Class C	57 New 57 Class A
57 New 57 Class A 57 Class B 57 Class C	60 Class B 60 Class C 48 New 48 Class A
48 New 48 New 48 Class A 48 Class B 48 Class C	57 Class B 60 Class C 57 and 60 Class C 57 and 60 Class C 57 and 60 Class C

- 6.2.4. When rails are chosen for a specific application, the price and remaining life as well as sleeper compatibility must be taken into account.

6.3 JUNCTION RAILS

- 6.3.1 Junction rails are used for joining rails of different sections, spanning either two, or alternatively three, rail masses.
- 6.3.2 Junction fishplates may only be used when the use of junction exothermic welds or junction rails is not possible.
- 6.3.3 Wherever possible junction exothermic welds must be used in stead of junction rails or fishplates.

6.4 CLOSURE RAILS

- 6.4.1 Closure rails may not be less than 4,2m in length and must be secured to all supporting sleepers.
- 6.4.2 Closure rails and the adjoining rail ends must be curved as in **clause 6.1.3**.
- 6.4.3 During rerailing work closure rails may be fastened with fishplates and with two G clamps, or with fishbolts in the outer holes of the fishplates. This is only a temporary measure to allow trains to pass through until the Track master leaves the work site at the end of a work day. **This measure is not applicable to heavy-haul lines.**
- 6.4.4 When rerailing work stretches over more than one day, closure rails may be fastened with fishplates and with four G clamps, or with fishbolts in all the holes of the fishplates. This is only a temporary measure to allow trains to pass through during the absence of the Track master from the work site in between shifts. This allowance is only valid for a period up to 48hours. **This measure is not applicable to heavy-haul lines.**
- 6.4.5 When closure rails are installed in track and left temporarily before exothermic welding the joints, both rail ends must be joined to the adjacent rails by fishplates and four fishbolts.
- 6.4.6 When closure rails are welded into the track all four rail ends must be free from dipped ends and fishbolt holes. Rails must be cropped and a longer closure used if necessary.

- 6.4.7 In the case of continuous rails the closure rail must be welded in within the destressing range (**clause 6.10.8**), and the rails on both legs must be destressed over at least 80 sleepers either side of each weld position. Where a break was caused by tensile stress, both rails must be destressed over a distance of at least 500m on either side.
- 6.4.8 All fastenings and rail off-cuts must be removed from site.
- 6.4.9 On electrified lines, jumper cables must be applied before starting work. (See **clauses 2.13.6 and 2.13.7 and 13.5.4.**)

6.5 CHECK RAILING

- 6.5.1 Check rails are provided to prevent excessive wear on the high legs of curves and to prevent derailments. See **Annexure 9, sheet 3.**
- 6.5.2 Check rails must start and end where the gauge of the track is 1 075mm.
- 6.5.3 Where new rails are used as check rails they provide a flangeway of 63mm. The maximum permissible flangeway is 83mm.
- 6.5.4 Re-gauging must not be carried out on check-railed track. Check rails must be renewed at the same time as high leg rails.
- 6.5.5 Reconditioned rails, classes B and C, may be used for check rails. Side-worn rails used as check rails must be placed so that wheelflanges of vehicles bear against the unworn edge.
- 6.5.6 Joints in check rails must be located between sleepers at least 3m from joints in low leg rails.
- 6.5.7 A gap 25mm wide must be left in the check rail opposite an insulating joint in the low leg running rail. The wearing edge must be chamfered 5mm over a length of 50mm on both sides of the gap.
- 6.5.8 Trains must not be allowed to pass over a curve from which a portion of the check railing has been removed, unless the remaining portion of the check rail has been fitted with tapered end pieces at both ends.

6.6 LAYING RAILS IN TRACK

- 6.6.1 General
 - 6.6.1.1 Rail temperatures must be measured by placing the thermometer on the flange or web of the rail and shading it from direct sunlight. The thermometer should remain in contact with the rail for at least ten minutes before readings are taken.
 - 6.6.1.2 Rails must be cut square and vertical and with a saw or a disc-cutter.
 - 6.6.1.3 All rails in tunnels must be welded into continuous lengths.
 - 6.6.1.4 Track circuit and other bonds should preferably be bolted to the rails. The Cad-method of welding may not be used with Cr.Mn.-rails.
 - 6.6.1.5 Exothermic welds must as close as possible be positioned halfway between sleepers.

6.6.2 Jointed track (fishplated rails)

6.6.2.1 Rails must be laid within the temperature ranges specified in **Annexure 16**. Correct expansion gaps must be provided by using shims which must be removed before trains are permitted to pass.

6.6.2.2 If 36m rails are laid outside the temperature ranges specified, the expansion gaps must be adjusted within the specified rail temperature ranges as soon as possible.

6.6.2.3 Rails must be laid with square joints. If stagger develops to more than 60mm owing to variations in rail lengths or track curvature, the rail must be cut.

6.6.2.4 Should jointed rails occur on unballasted bridges in a section of track with continuous rails, permanent splice joints must be provided:

- At both ends of multiple-span bridges.
- At both ends of bridges having a single span greater than 25m.
- At the free end of a bridge having a single span of 25m or less.

The splice joint must be at least 9m from the back of the ballast wall and clear of any safety rail.

6.6.2.5 Rail joints must not be placed less than 3m from deck supports or ballast walls. There must be no rail joints on spans of less than 7m.

6.7 CONTINUOUS RAILS

6.7.1 General

6.7.1.1 Continuous rails are rails longer than 36m.

6.7.1.2 Continuous rails must be 40kg/m or heavier, depending on permitted axle loads.

6.7.1.3 Concrete, wood or 40kg steel sleepers may be used.

6.7.1.4 Ballast must be sufficient and of acceptable standards.

6.7.1.5 In this clause the term 'rerailing' includes final jointing of rails, by exothermic welding or otherwise. Destressing of rails within the appropriate temperature range forms part of the laying of continuously welded rails.

6.7.1.6 'The destressing range' means the appropriate temperature range, as per clause 6.10.7.

6.7.1.7 The laying and destressing of continuous rails must be managed by an Engineer or an Engineering Technician.

6.7.1.8 A complete record must be kept on form T1286(M) when destressing and/or welding is carried out.

6.7.1.9 On continuous railed track the geometry should be maintained to a standard equal or better than the B standard.

6.7.2 Track structure for running lines

6.7.2.1 Crossing loops are classified as running lines.

- 6.7.2.2 Continuous rails may be used on tangent track and curved track down to 800m radius, provided that the sleeper spacing is not more than 800mm.
- 6.7.2.3 For concrete sleepered track the radii of curves on which continuous welded rails are used may be reduced to 600m radius provided that the sleeper spacing does not exceed 700mm and 400m radius provided that the ballast profile is at least 3000mm or the sleeper spacing is not more than 600mm.
- 6.7.2.4 In the case of steel and wood sleepers the radii may be reduced to 600m provided that the sleeper spacing does not exceed 700mm.
- 6.7.2.5 Where a curve consisting of jointed track is joining unto a section of continuously welded rails, a transition length of jointed track of at least 80 sleepers between where the curve ends/begins and the continuously welded rails begins/ends must be applied.
- 6.7.2.6 With special written permission from the Assistant General Manager (Infrastructure-Maintenance) continuous rails may be used on curves with sharper radii than 400m (see clause 6.7.9).
- 6.7.2.7 Wood sleepers must be fitted with type E3131 chairs.
- 6.7.3 Track structure for yard tracks
- 6.7.3.1. Continuous rails may be used on tangent track and curved track down to 600m radius, provided that sleeper spacing is not more than 800mm.
- 6.7.3.2. Concrete sleepers with FIST fastenings may be used under locking and safety bars. The open end of the clip must be on the outside of the rail.
- 6.7.3.3. Steel sleepers of 40 kg may be used at 800mm spacing under continuous rails down to and including 400m radius but 80 sleepers at the turnout ends of the continuous rails must be at 700mm spacing. Steel sleepers may not be used under locking and safety bars.
- 6.7.3.4. Fishplated joints on turnouts may be exothermic welded if the points blades do not require frequent replacement and the rail mass is 40kg/m or greater.
- 6.7.4 Laying continuous rails within the destressing range
- 6.7.4.1 While rerailling, trains may be allowed to pass at 30 km/h if every fourth sleeper is fully fastened and temporary rail joints are made with joggle fishplates secured with two clamps, provided the Track master is present on site. Refer clause 6.4.3. and 6.4.4.. The speed of 30 km/h must apply until all the sleepers have been secured and permanent rail joints have been completed. Temporary expansion gaps must be set to facilitate final jointing.
- 6.7.4.2 Rails must at least be fastened to alternate sleepers within the limits of the destressing range, and the fastenings on all the other sleepers must be tightened before the limit of range B is reached. Rerailling that was not completed as above must proceed as in **clause 6.7.5.**
- 6.7.4.3 The left and right-hand rails must be fastened down simultaneously.
- 6.7.4.4 The last 80 sleepers of previously laid track must again be destressed before rerailling is resumed.

- 6.7.4.5 Short track lengths may be destressed at a time, provided the procedures set out herein are adopted.
- 6.7.4.6 Rerailing more than 20m inside a tunnel is not subject to destressing temperature considerations.
- 6.7.5 Laying of continuous rails outside the destressing range
- 6.7.5.1 Rerailing may proceed within the limits of temperature range B. Refer clause 6.7.1.5.
- 6.7.5.2 While rerailing, trains may be allowed to pass at 30 km/h, if every fourth sleeper is fully fastened and temporary rail joints are made with joggle fishplates secured with four clamps.
- 6.7.5.3 After rerailing, all sleeper fastenings and all fishbolts must be tightened and a speed restriction of 30 km/h must be imposed until the track has been destressed.
- 6.7.6 Laying of continuous rails on new formation
- 6.7.6.1 The new formation must be approved by an Engineer before track laying is commenced.
- 6.7.6.2 Traffic may only run on newly laid track after the sleepers have been packed sufficiently to ensure adequate and even bearing and to provide a uniform running top.
- 6.7.6.3 To ensure the safe use of the track during ballast consolidation, the rails must be destressed after the track has been fully ballasted, packed and aligned. Prior to destressing a speed restriction of 30 km/h must be applied to construction trains.
- 6.7.6.4 After the ballast has been consolidated the rails must again be destressed. A speed restriction of 50 km/h must be applied from the first destressing up to this point.
- 6.7.7 Laying of continuous rails on unballasted bridges
- Continuous rails may be laid over unballasted single and multiple-span bridges of any length and the splice joints omitted provided that:
- 6.7.7.1 Type E3131 chairs are fitted on all the sleepers and that all the chairs except those on 5 consecutive sleepers at the fixed end of each span are fitted with type E3205 washers.
- 6.7.7.2 When laying new rails, exothermic welds on bridges must be avoided, and must be kept as far off the bridge as possible - preferably more than 20m.
- 6.7.7.3 If exothermic welds cannot be avoided, rail ends must be cropped to eliminate all fishbolt holes.
- 6.7.7.4 On completion of all exothermic welding of joints on the bridge, the rails must be destressed before commencing with the nearest welds off the bridge. On completion of destressing, the clip bolts of the anchoring sleepers at the fixed end(s) of the bridge span(s) must be firmly tightened.
- 6.7.8 Slacks, kinks and kick-outs
- 6.7.8.1 Should slacks, kinks or kick-outs occur in continuous rails, prompt protective measures must be taken.

- 6.7.8.2 Kick-outs in track with continuous rails must be eased to prevent further deterioration, provided the track is not pulled out from under the traction contact wire. Electrical must be called out when a kick-out occurs on an electrified section. Trains may be allowed to pass over the affected portion of the track if this can be done with safety. Depending on the seriousness of the situation, a temporary speed restriction must be imposed.
- 6.7.8.3 The track alignment must be restored only when the rail temperature is within the destressing ranges.
- 6.7.8.4 In all cases where kick-outs occur the rails must be cut and destressed for at least 500m on either side of the kick-out point.
- 6.7.8.5 The track (both rails) must be destressed over a distance of 500m on either side of where the track has been disturbed i.e. long slacks repaired, track lifted, re-alignment was done or sleepers replaced.
- 6.7.9 Continuous rails on sharp curves (see clauses 6.7.1. and 6.7.2.)
- 6.7.9.1 Special destressing temperature ranges (other than those in Annexure 16), specific conditions for tamping and ballast cleaning, as well as specific conditions that apply to each curve, must be recorded in **chapter 20**.

6.8 RAIL JOINTS

- 6.8.1 Fishplated joints
 - 6.8.1.1. At least once a year, fishplated joints on running lines must be inspected. Where necessary the fishplates must be removed, cleaned, lubricated and reversed before being replaced. The fishplates and rail ends must be examined for cracks.
 - 6.8.1.2. Except for destressing and exothermic welding, fishplates on rails 36m and longer must only be removed when the rail temperature is within the ranges specified in clause 6.10.7.
 - 6.8.1.3. The fishing surfaces of fishplates and rails must be cleaned and greased, and the threads of fishbolts must be oiled, before being used.
 - 6.8.1.4. Where rails are bonded for electrical track circuits, the nuts of the fishbolts must at all times be on the inside of the track. Reversal must be effected by transferring the fishplates from one rail to the opposite rail.
 - 6.8.1.5. Fishplated joints must at all times be bolted with all its bolts in place and firmly tightened.
 - 6.8.1.6. Fishbolts must be fitted with spring washers or self-locking nuts.
 - 6.8.1.7. Rail fastenings must be kept uniformly tight. Lengthening bars must not be used on fishbolt spanners.
 - 6.8.1.8. Pressed-to-parallel fishplates may be used with new rails and reconditioned second hand rails. They are stamped "P-P".
 - 6.8.1.9. Enlarged fishplates stamped "E" are for replacing fishplates where the wear of the rail fishing surface justifies their use. They must not be used with new or reconditioned rails.
 - 6.8.1.10. Worn fishplates are not to be used in the track.
 - 6.8.1.11. Fishplate holes must be drilled and sharp edges must be removed.

- 6.8.1.12. The sleepers on either side of fishplated joints must be of the same type and special attention must be afforded to the tamping of these sleepers.
- 6.8.1.13. The use of a template is recommended when drilling fishbolt holes.
- 6.8.2 Insulating joints / block joints
- 6.8.2.1 An insulating joint (commonly called a block joint) is used to insulate one rail from the next for either signalling or electric traction purposes. Signals or Electrical will indicate where block joints are required. The Track master must fit and replace block joints. If possible, Signals or Electrical should be present. If Signals was not present, the Track master must inform the train control centre/traffic controller, as the case may be, once the block joint has been renewed.
- 6.8.2.2 Block joints for traction purposes are those insulating non-electrified track from electrified track and those provided on sidings on which flammable liquids are handled.
- 6.8.2.3 When block joints are inserted in curves, **clause 6.1.3** applies. With prefabricated block joints the jim-crow must not be allowed to span the joint. See **clause 6.5.7** for the installation of block joints in check railed curves.
- 6.8.2.4 The installation of block joints on open lines involves breaking the track. (See **clauses 2.13.6 and 2.13.7**)
- 6.8.2.5 Work on block joints may only be performed within the appropriate destressing or working temperature ranges (see **clause 6.10.7**).
- 6.8.2.6 Renewal and maintenance of block joints must be performed in accordance with the latest work code.
- 6.8.2.7 New block joints must be shortened to the minimum length before installation in order to eliminate the need for additional closures during subsequent block joint replacements. Refer clause 6.4.1.
- 6.8.2.8 The block joint gap must be limited to between 4mm and 6mm by using one T-piece only.
- 6.8.2.9 Worn ballast must be screened out and replaced. Fastenings and block joint bolts must be firmly tightened before thorough tamping of the block joint.
- 6.8.3 Splice joints
- 6.8.3.1 Splice joints must be provided at unballasted bridges, as set out in **clause 6.6.2.4**.
- 6.8.3.2 Splice joints may be used to protect sets and curves, if authorised by the Depot Engineer. In cases where the conditions for continuously welded rails cannot be adhered to safely, splice joints must be used.
- 6.8.3.3 Splice joints must be renewed before crown wear exceeds 6mm.
- 6.8.3.4 Splice joints must be installed and set as follows:
- Before welding of the continuous rail has taken place the gap at the point must be adjusted to 25mm.
 - The gap must be set immediately before welding to the continuous rail. It must be increased or decreased from the mean setting (which is 50mm from the closed position) by 1mm for every 2°C by which the temperature is lower or higher than the lower limit of the destressing temperature range.

- Welding of splice joints to adjoining rails after final setting of the gap must be completed within the destressing temperature range.

6.9 RAIL CREEP

- 6.9.1 Fastenings securing rails to sleepers must be kept tight. This will help to prevent creep.
- 6.9.2 Development of creep must be kept under observation and reported to the Depot Engineer.
- 6.9.3 If creep develops to such an extent as to disturb sleepers and cause wide or tight joints, the rails must be pulled back and expansion gaps adjusted. Sleepers must be adjusted and fastenings replaced if necessary.
- 6.9.4 Tapered keys must be driven in the direction in which the forces on the rails appear to predominate, or in the direction of obvious creep. Where there is a tendency for keys to work loose, they must be reversed.

6.10 RAIL DESTRESSING

- 6.10.1 Because of the length of continuous rails, the stresses building up in them as a result of changes in temperature are very high. The lifting frame must be used to measure the stress free temperature. If the stress free temperature is found to be outside the limits of the A range, destressing must be carried out.
- 6.10.2 Destressing should also be considered after replacing sleepers, after ballast cleaning, when kick-outs have occurred, when the rail breaks or is cut, or when rail creep is observed. Refer to the decision guidelines and relevant work codes for rail destressing.
- 6.10.3 In all instances that destressing is called for, measuring of the rails' stress free temperature with the lifting frame should be considered. If the stress free temperature of both rails is within the destressing range, and also within 5°C of one another, the track may be considered as sufficiently stress free. In those areas where the lifting frame indicates excessive or unbalanced rail stress, destressing must be done.
- 6.10.4 Whenever the stress free temperature of the rail is known to be or is expected to be outside the destressing temperature range, a temporary speed restriction of 30km/h must be applied until the rails are destressed or shown to be safe by the use of the rail stress lifting frame.
- 6.10.5 The stress free temperature is always at mid-point of the destressing temperature range. When destressing, the aim should be to have stress free rails. Depending on local conditions (e.g. rails' susceptibility to breaks resulting from tension stress, actual ballast profiles and sleeper spacing) and with written approval of the Depot Engineer, destressing may be aimed at other temperatures - but always within the destressing temperature range.
- 6.10.6 If that part of the day when the rail temperature is within the destressing range is uneconomically short, rail tensors must be used. Rail tensors provide excellent control over the destressing process.
- 6.10.7 When laying, destressing or welding continuous rails, the rail temperature must be taken and recorded every half hour.
- 6.10.8 Destressing temperature ranges are shown in **Annexure 16**.
- 6.10.8.1 Where the laying of continuous rails on sharper radii was approved (see **clauses 6.7.2.5 and 6.7.9**) special conditions will apply to each individual curve.

6.11 EXOTHERMIC WELDING OF RAIL JOINTS

- 6.11.1. Approximately half of all rail breaks occur in exothermic welded joints.
- 6.11.2. The work code for track welding must be followed conscientiously.
- 6.11.3. All preparatory, finishing and destressing instructions must be complied with.
- 6.11.4. Occupation time required to complete an exothermic weld in accordance with specification for normal (grade 700 or 900A) rails, is approximately 45minutes. Additional time is required for the preparation and finishing of the joint. For CrMn (grade 1100) rails more time would be needed.
- 6.11.5. On electrified sections electrical continuity must first be provided as described in **clause 13.5.4.**
- 6.11.6. Welding personnel must inspect every exothermic welded joint and keep a record of the following:
 - Location of joint.
 - Manufacturer's portion number.
 - Temperature before work is commenced and on completion of rough grinding.
 - Welder's code and joint number
 - Date welded
- 6.11.7. When exothermic joints fail, the whole joint must be removed and replaced with a wide gap joint where possible.
- 6.11.8. Sleepers on both sides of an exothermic weld must be of the same type and should receive special attention during tamping.

6.12 REPAIR OF BATTERED AND MISMATCHED RAIL ENDS AND CARE OF WELDED JOINTS

- 6.12.1 Effective and efficient joint maintenance will reduce battered rail ends.
- 6.12.2 Battered rail ends must be repaired as soon as possible.
- 6.12.3 The cropping and repositioning of rails must always be considered.
- 6.12.4 Rail-end batter must not be welded if bolt holes have deformed.
- 6.12.5 Block joint rails must not be welded with the insulating fishplates in position.
- 6.12.6 Once work has been completed joint maintenance must be improved.
- 6.12.7 The work code for track welding must be followed conscientiously; and
- 6.12.8 all preparatory, finishing and destressing instructions must be complied with.
- 6.12.9 Mismatched joints will be reduced if re-conditioned and second hand rails are selected with the aim of improved matching.
- 6.12.10 Engineers must pay special attention to the maintenance of flash-butt joints on CrMn. - rails.
- 6.12.11 Cadwelds may not be used with CrMn.-rails. Instead huckbolted connections must be used for cable bond connections.

6.13 REPAIR OF WHEEL SPIN DAMAGE

- 6.13.1 Severe wheel spin damage must be treated with the same urgency as a rail break.
- 6.13.2 Wheel spin damage will be reduced if drivers, Operating, Signals and Locomotive and Truck maintenance are involved in solving the problem.
- 6.13.3 Where wheel spin damage occurs repeatedly the use of reconditioned or second hand rails must be considered.
- 6.13.4 The work code for track welding work must be followed conscientiously.
- 6.13.5 All preparatory, fettling, finishing and distressing instructions must be complied with.
- 6.13.6 If repair of wheel spin damage cannot be effected immediately, the use of special absorbent rubber pads to minimise damage to the track structure must be considered as an interim measure.
- 6.13.7 Wheel spin burns up to 1mm deep can be repaired by grinding. Wheel spin burns deeper than 1mm but less than 6mm must be repaired by welding and grinding. Wheel spin burns deeper than 6mm must be repaired by cutting the effected rail and replacing it with a closure rail. Wheel spin burns must be repaired in accordance with the welding specification SSS7. Nests of wheel spin burns must be evaluated by the Depot Engineer to determine the most productive repair method.

6.14 BROKEN AND DEFECTIVE RAILS

- 6.14.1 Typical rail defects and fractures are illustrated in Annexure 17, sheets 1, 2 and 3.
- 6.14.2 Broken or defective rails are potentially dangerous and must be thoroughly examined immediately. Trains may, except in the case of heavy-haul lines, be allowed to pass over broken or defective rails under the conditions set out in Annexure 17, sheet 4.
- 6.14.3 On heavy-haul lines with CrMn rails, temporary remedial measures require special conditions, which must be recorded in chapter 20. (Also see clause 13.5.4.)
- 6.14.4 Before permanent repairs are undertaken on track-circuited sections or electrified lines, Electrical or Signals must be advised.
- 6.14.5 A T447-report, in respect of each broken or defective rail removed from the track, must be sent to the controlling office each month. If no such rails were removed during the month, a nil return must be submitted. An effective system of control, which will ensure that T447-reports are submitted for all rail fractures, must be introduced in conjunction with Operating.
- 6.14.6 When broken rails, frogs and points cause derailments, the broken sections must be despatched to the Track Testing Centre, where arrangements will be made for the required analysis.
A sample of approximately 0,5m on either side of the break is required. To facilitate identification, a copy of the T447 report must accompany the sample.
- 6.14.7 Rails in running lines in which defects are detected ultrasonically, must be marked and dealt with as set out in Annexure 17, sheet 5. Defective rails must be cut out and replaced in accordance with Annexure 18.

6.14.8 Any clean vertical break in a rail, a flash-butt weld or a exothermic weld can be repaired by exothermic welding, provided that all existing welding material is removed. Such breaks can be repaired as a temporary measure(except in the case of heavy haul lines) by using joggled fishplates, which are kept in place with four firmly tightened bolts, to permit the passage of trains. In such cases a temporary speed restriction of 30 km/h must be introduced. All other broken and defective rails must be cut out and replaced in accordance with Annexure 18.

6.14.9 All defective rails that are removed from the track, must be rendered unfit for further service by burning or cutting grooves across the crown at intervals of not more than two metres. The rail ends must be painted red.

6.15 RAIL WEAR

6.15.1 The maximum permissible wear for all types of rail is as for class C rail according to Annexure 15 sheet 2.

6.15.2 All approved rail wear gauges may be used. The method of using a rail wear gauge is shown in Annexure 15 sheet 1.

6.15.3 The Maintenance Manager (Track) must take measurements and keep a progressive record to establish the rate of wear of rails. This will enable corrective maintenance measures to be taken where necessary and new rails to be ordered in good time.

6.16 RAIL LUBRICATORS

6.16.1 Refer to the latest work code and decision guidelines for the positioning, installation and maintenance of rail lubricators.
For additional information refer to Annexure 19, circular 50161 and drawings E1051, E3212, E3213 and E3243.

6.16.2 The exact location of lubricators must be determined by an Engineer or Engineering Technician.

6.16.3 All curves up to a radius of 1 200m should be lubricated.

6.16.4 Lubricators should be placed on a curve where the offset on a 10m chord is 10 to 15mm, or just before the point on the rail where there are signs of contact between wheel flanges and the rail.

6.16.5 Lubricators should not be placed at roll marks or where heavy sanding takes place.

6.16.6 Check rails must be extended to the straight track (where the gauge is 1 065mm) for installation of check rail lubricators.

6.16.7 Rail and flange lubricators or special points lubricators must be used for the lubrication of points blades of turnouts in yards.

6.16.8 Lubricant must not be deposited on the crown of the rail. The greasing plates must be adjusted to 20mm to 22mm below the top surface of the rail.

6.16.9 Rail lubricators must be maintained and adjusted by qualified personnel.

6.16.10 Repairs must be undertaken in a workshop and by qualified personnel.

- 6.16.11 The Track inspector must arrange for the filling and cleaning of lubricators.
- 6.16.12 Lubricators must be checked where on-track machines have worked, to ensure that they have been correctly replaced, properly filled and are in good working order.

6.17 STOP BLOCKS

- 6.17.1 The back end of a sliding stop block should be approximately 3m from the end of the running rail.
- 6.17.2 Stop blocks must be painted white.
- 6.17.3 The use of a single leg stop block is not permitted.

6.18 DERAILING DEVICES

- 6.18.1 Scotch blocks, derailleurs, run-away points, catch points and derail points (collectively called derailing devices), must be fitted at least 2m outside the clearance mark (away from the turnout), to derail vehicles to the side, away from the more important track and clear of any important structures such as electrification masts and signals. Also see clause 8.3.1.5.
- 6.18.2 Hand operated hinged derailleurs must be installed in accordance with drawing E853.
- 6.18.3 Scotch blocks and derailleurs must be painted white.
- 6.18.4 Scotch blocks must be fitted on the outside rail with the hinge on the same side as the track which it is required to protect and lie with the points lock one sleeper nearer to the turnout.
- 6.18.5 Non-compounded derailing devices must be equipped with chains and points locks.

CHAPTER 7

SLEEPERS AND BALLAST

7.0 SLEEPERS AND FASTENINGS

7.0.1 General

- 7.0.1.1 Sleepers must be off-loaded as close as possible to the time that they are required and in accordance with the maintenance plan.
- 7.0.1.2 Sleepers must be laid square to the rails.
- 7.0.1.3 Sleepers must be tamped to the same extent.
- 7.0.1.4 All sleeper fastenings must be in place and at all times properly fastened.
- 7.0.1.5 The contact areas of clips and rail flanges must be kept free of lubricant.
- 7.0.1.6 Proprietary fastenings and those using multi-coil spring washers must be tightened in accordance with the relevant instructions.
- 7.0.1.7 Anti-vandal clips must be fitted where necessary.
- 7.0.1.8 Mixing of different types of sleepers in the same sub-section, must be avoided.

7.0.2 Inspections

Refer to clauses 4.0.1, 4.0.2 and 4.0.8.

7.0.3 Wood sleepers

- 7.0.3.1 Hardwood sleepers must be laid with the heart down. Laminated wood sleepers may be laid either side down.
- 7.0.3.2 Sleepers must be handled with care so that the outer layer of treated wood is not punctured or damaged.
- 7.0.3.3 The diameter of holes for coach screws must be 15mm for softwoods and 17mm for hardwoods.
- 7.0.3.4 Holes for coach screws must be drilled square to the sleeper surface. Holes must go right through the sleeper (in which case 25mm long dowels must be inserted and driven to the bottom of the holes). Alternatively the drill must be fitted with a depth indicator/stopper that will ensure that holes are 15mm deeper than the selected coach screw to be inserted. Newly drilled holes or holes still in good condition, must be filled with creosote before the coach screws are inserted. In the case of existing worn holes either epoxy or 'Vortok' coils may be used.
- 7.0.3.5 If sole plates or chairs with tapered keys are to be used and where gauge widening has to be applied, the holes at one end only of the sleeper may be drilled before the sleeper is placed into the track. The holes at the other end of the sleeper must be drilled after the rails have been laid to the correct gauge.
- 7.0.3.6 If chairs with clip fastenings are to be used, all holes may be drilled by using templates before the sleepers are put into the track.

- 7.0.3.7 Old holes that will not be used again must be plugged with dowels, 125mm long, dipped in oil or creosote. 'Vortok' coils should be used to regain holding-down force.
- 7.0.3.8 Coach screws must be screwed home tightly by means of a box spanner or a coach screwing machine.
- 7.0.3.9 In curves on running lines and in sets and splice joints, all anchor points of each rail seat must be provided with coach screws. In all other instances two coach screws (placed diagonally) must be provided per rail seat.
- 7.0.3.10 Different types of coach screws are used as follows:

Type	Shank length	Used with
H	160mm	Concrete slabs and with nylon inserts, on E3282 chairs and concrete sleepers
HC	192mm	do. With nylon inserts, on E3338 chairs
F	158mm	Hardwood Chairs with ≥ 30 mm base thickness, with double-coil spring washers
A	146mm	do. Chairs with ≥ 30 mm base thickness
B	130mm	do. Sole plates and chairs with base < 30 mm
D	130mm	do. Locking bars
AL	186mm	Softwood (195mm) All chairs/sole plates

- 7.0.3.11 Released wood sleepers must be classified as follows and marked with a paint spot of the appropriate colour (50mm in diameter) on both ends of each sleeper.

Class	Colour	Application
2	White	Suitable for running lines
3	Blue	Suitable for yards
4	Red	Unsuitable for use

- 7.0.3.12 Sound sleepers must not be removed because of the number of coach screw holes. Worn holes must be restored. Broken coach screws that cannot be removed must be cut off and the open holes must be plugged. The sleepers must be used with an offset of about 75mm (alternatively to left and right).
- 7.0.3.13 The combined use of different thickness wooden sleepers in the same turnout set must not be allowed as it leads to uneven support and tamping of the set as a whole.
- 7.0.3.14 All cast iron and sliding chairs must be fitted as near as possible to the centre of the sleeper over its width. Coach screw holes must not be drilled within 50mm from the sleeper edge.

7.0.4 Steel sleepers

- 7.0.4.1 On electrified sections, ballast must consist of stone and must be kept clean.
- 7.0.4.2 Instructions regarding the installation of insulating pads must be implicitly followed.
- 7.0.4.3 Clip bolts must be fitted with spring washers or self-locking nuts.
- 7.0.4.4 Clip bolts must be lubricated before they are tightened.

7.0.4.5 The ballast bed at the end of steel sleepers must be opened up to expose the sleeper ends and the ballast must be loosened before re-alignment is attempted. The sleepers must not be packed until the track has been pulled to true alignment.

7.0.4.6 Released steel sleepers must be classified as follows and marked with a paint spot of the appropriate colour (50mm in diameter) on both ends of each sleeper.

<u>Colour</u>	<u>Application</u>
Green	Useable
Yellow	Repairable
Red	Scrap

7.0.4.7 Steel sleepers must not be used within 10 km of the coast.

7.0.5 Concrete sleepers

7.0.5.1 Concrete sleepers may be used on curves with a radius flatter than 150m.

7.0.5.2 Concrete sleepers must be off-loaded as described in the work code, and may not be thrown from trucks or tipped out of tip trucks. After completion of off-loading, track personnel must make sure that all sleepers are clear of the structure gauge.

7.0.5.3 Within 10km of the coast and inside tunnels, sleeper fastenings must be galvanised. Sleepers with Fist fastenings should only be used with stone ballast, and not in yards where moist conditions resulting from infill material can cause rust.

7.0.5.4 Pandrol and Fist clips must only be applied by means of Panpuller or Fist-levers. The use of the incorrect tools leads to a reduction in the clamping force life of the clips. The clamping force life of the Fist clip expires after 7 cycles of loosening and fastening. The unnecessary loosening and fastening of Fist and Pandrol clips must therefore be avoided.

7.0.5.5 Where wheel spin burns cause damage to concrete sleepers with Fist fastenings, the HDPE pads on four consecutive sleepers must be temporarily replaced with rubber pads. The HDPE pads must be replaced as soon as the rail is repaired,.

7.0.5.6 Before traffic is permitted over track laid on newly inserted concrete sleepers, the sleepers must be packed sufficiently to ensure adequate and even bearing.

7.0.5.7 Dual-block sleepers' tie bars are to be left exposed for easy inspection. In running lines all sleepers with cracked or broken tie bars must be replaced. In yards it is adequate to replace every fourth sleeper with a sound sleeper to hold the track true to gauge.

7.0.5.8 Where concrete sleepers are damaged to the extent that they cannot maintain gauge, the track may be temporarily repaired by installing wood sleepers, steel sleepers or gauge straps. On sections where track circuits exist only wood sleepers, monoblock concrete sleepers or isolated gauge straps may be used. For purposes of temporary repair every fourth sleeper may be replaced in this way. A temporary speed restriction must be applied until permanent repairs are effected.

7.0.5.9 Sufficient quantities of gauge straps must be kept in stock at strategic locations for emergency use.

7.0.5.10 The re-use of second hand concrete sleepers must be done in accordance with circular number IM/L01 of 11 March 1999.

- 7.0.6 Resleeping under continuously welded rails (by hand)
- 7.0.6.1 During resleeping, the speed of trains must be restricted to 30 km/h.
- 7.0.6.2 After resleeping has been completed, a speed restriction of 50 km/h must be applied until the ballast has consolidated.
- 7.0.6.3 At least 8 sleepers on both sides of any sleeper being removed must be fully packed and boxed in. Each replacement sleeper must be well packed and boxed in before an adjacent sleeper is removed.
- 7.0.6.4 When resleeping, the ballast under the sleeper and in the adjacent cribs must be completely removed, cleaned, replaced and tamped before adjacent sleepers are disturbed.
- 7.0.6.5 In tunnels (to within 20m of tunnel portals), sleepers may be replaced consecutively, at any temperature.
- 7.0.6.6 On track with continuous rails, resleeping with wood or steel sleepers can take place at any temperature below the maximum of range B. Resleeping with concrete sleepers can be undertaken up to the maximum of temperature range C in accordance with Annexure 16.

7.1 BALLAST

7.1.1 General

- 7.1.1.1 Ballast must comply with the latest specification.
- 7.1.1.2 Worn ballast must be replaced without delay.
- 7.1.1.3 Ballast from quarries must be checked at the source and loading point, and must be tested from time to time, to ensure that specified standards are complied with.
- 7.1.1.4 The volume of ballast in each truck must be measured before offloading to ensure that specified quantities are loaded at quarries.
- 7.1.1.5 Equal volumes must be off-loaded simultaneously from both sides of trucks. Ballast trucks that have been loaded or off-loaded disproportionately may derail and must not be send off.
- 7.1.1.6 Dimensions and quantities must be in accordance with **Annexures 3 and 4**.
- 7.1.1.7 Ballast must be clear of the rail flange and sleeper fastenings (except at level crossings). When off-loading, or whilst cleaning ballast, the top of the ballast must not be left higher than the underside of the crown of the running rail.
- 7.1.1.8 The flangeways between running rails and guard or check rails and between running rails and points rails, must be kept clear of ballast.

7.1.2 Ballast cleaning

- 7.1.2.1 The decision guidelines must be used to determine cleaning priorities. On track-circuited sections ballast must be kept clean.
- 7.1.2.2 All track, including sets, must be regraded when ballast is cleaned.

- 7.1.2.3 Special attention must be given to vertical and horizontal clearances.
- 7.1.2.4 No ballast screening work must be undertaken before level and line pegs have been provided. On completion, the vertical profile and clearances must be checked to ensure that work has been executed according to plan.
- 7.1.2.5 On track with continuous welded rail with:
- wood or steel sleepers, cleaning of ballast can take place when rail temperature is below the maximum of range B
 - concrete sleepers, the work may continue until the maximum temperature of range C is reached.
 - Special care must be taken against kick-outs when the temperature falls outside destressing range (range A).
- 7.1.2.6 A speed restriction of 30km/h must be imposed for the duration of the ballast work (including replenishment, tamping and profiling of ballast). The speed restriction may be increased to 50km/h after the work has been completed. The speed restriction must be maintained until the ballast has consolidated.
- 7.1.2.7 After the ballast has consolidated and tamping has been completed, the gaps at fishplated joints must be adjusted and continuous welded rails must be destressed.
- 7.1.3 Ballast cleaning by hand
- 7.1.3.1 **Clause 7.1.2** applies.
- 7.1.3.2 Cleaning of ballast 'between trains' (i.e. removing, cleaning and replacing the ballast) must be carried out under and adjacent to one sleeper at a time in a batch of 8 sleepers. The ballast must be tamped before work under the next sleeper is commenced.
- 7.1.3.3 If work cannot proceed as in **clause 7.1.3.2**, cleaning must be done under total occupation.
- 7.1.4 Ballast cleaning by machine
- 7.1.4.1 Clause 7.1.2 applies.
- 7.1.4.2 Work must be done under total occupation.
- 7.1.4.3 The track must be lifted sufficiently before screening commences if there is a possibility that the cutting chain might cut into the formation.
- 7.1.4.4 Boxing in of ballast must be done immediately behind the ballast cleaning machine. Additional ballast must be provided if necessary. The track must then be tamped, followed by a final tamp at a later stage, unless a stabiliser is used as part of the ballast screening process.
- 7.1.5 Ballast tamping
- Track laid with continuous rails may only be tamped by the heavy ballast tamping machine within temperature range B. The full ballast profile must be maintained at all times when tamping is done above the upper limit of temperature range A.

CHAPTER 8

CLEARANCES AND DIMENSIONS

8.0 MINIMUM CLEARANCES BETWEEN TRACK AND STRUCTURES

- 8.0.1 Structures next to 1 065mm gauge track must be clear of the limits indicated by the full lines in Annexure 1, sheets 1 to 3, except in the case of tunnels, workshop areas and temporary works. These clearances allow additional space for handling of material, for electrification purposes and for reducing the risk to persons working in close proximity to moving trains. These clearances may only be reduced in exceptional circumstances, with the approval of the Depot Engineer.
- 8.0.2 Structures next to 610mm gauge track must be clear of the limits indicated by the full lines in Annexure 1, sheets 3 and 5.
- 8.0.3 Structures clear of the limits indicated by the dashed lines shown in Annexure 1, sheets 1 and 2 and clear of the full lines where no dashed lines are shown (i.e. platform level and below), are safely clear of passing trains. Temporary structures, tunnels and structures in workshop areas must not be closer to the track.
- 8.0.4 Horizontal clearances to the dashed lines in Annexure 1, sheet 1 are 300mm less than the tabulated values for horizontal clearance.
- 8.0.5 A structure, or any part of it which is adjacent to 1 065mm gauge track and which is not clear of the limits indicated by the dashed lines or full lines where no dashed lines are shown in Annexure 1, sheets 1 and 2, must be regarded as foul. Those parts of the structure which are foul must be painted as described in clause 8.1. The same action must be taken in the case of a structure or any portion of a structure which is adjacent to a 610mm track and not clear of the full lines described in clause 8.0.2.
- 8.0.6 A list of structure gauge fouling points must be obtained from the Depot Engineer. The list will show the kilometre distances and measured clearances and heights of fouling points. The listed clearances may not be reduced.
- 8.0.7 Wires crossing non-electrified railway tracks must not be less than 6m above rail level.
- 8.0.8 Clearances for new structures are greater than those tabulated in Annexure 1. Details may be obtained from the Depot Engineer.
- 8.0.9 The distances from platform edge to track centre line as shown in Annexure 1, sheet 3 are minimum distances and may be exceeded by up to 50mm.
- 8.0.10 The height indicated for high level platforms is the maximum allowable. Platforms may be no more than 40mm lower than this height. See Annexure 1, sheet 3.
- 8.0.11 Clauses 8.0.1 to 8.0.6 are also applicable to objects such as rocks protruding from the sides of cuttings.
- 8.0.12 Movement of rail traffic which could involve any exceedance of the Structure Gauge must be handled strictly in accordance with the Procedure for Approval of Abnormal Loads.

8.1 **MARKING OF FOULING POINTS**

A fouling point as defined in clause 8.0.5 must be painted with alternate black and yellow diagonal stripes each 200mm wide. The markings should cover an area of approximately 1 000 x 200 mm where practical, and be in the most conspicuous position when seen from an approaching train. In cases such as in tunnels, where the fouling point may be somewhere inside the tunnel, the entrance portals must be painted with stripes on the same side and at the same height as the fouling points.

Where the fouling point is an object such as a rock protruding from the side of a cutting and painting with stripes is impractical, it must be painted white.

8.2 **ELECTRIFIED SECTIONS : HEIGHT OF CONTACT WIRE**

8.2.1 The minimum height of the contact wire above rail level on 3kV sections is 4,22m. This may occur through old tunnels and at old bridges.

8.2.2 The minimum contact wire height on 25kV and 50kV sections is 4,5m.

8.2.3 At points where the contact wire is at or near minimum height, permanent reference pegs must be provided. The track must not be raised above peg level.

8.2.4 At level crossings the minimum height of the contact wire above rail level and the minimum clearances to be provided by height gauges are:-

Line Voltage KV	Minimum contact wire height Metre	Minimum clearance Mm
3	4,5	300
25	5,0	300
50	6,0	500

8.2.5 Measurement of the contact wire height is the responsibility of Electrical.

8.2.6 Before implementation of any deviation from the above standards, such intended deviation must be documented and approved by the Infrastructure Manager. After approval it must then be included in chapter 20 of this manual.

8.3 **TRACK CENTRES**

8.3.1 1 065mm gauge

8.3.1.1 Minimum distance between centres of parallel tracks 4m

8.3.1.2 Minimum distance between centres of parallel tracks with traction masts, telegraph poles, water columns, signal poles or parachute tanks 5,5m

8.3.1.3 In yards, up to 4 adjacent tracks may be at 4m centres. Distance to the next track 5,5m

8.3.1.4 Centres of tracks at clearance marks 3,45m

8.3.1.5 Minimum track centres at derailing devices 3,65m

8.3.2 610mm gauge

8.3.2.1 Minimum distance between centres of parallel tracks 3,4m

- 8.3.2.2 Minimum distance between centres of parallel tracks with telegraph poles, water columns, signal poles or parachute tanks 5m
- 8.3.2.3 Centres of tracks at clearance marks 2,75m
- 8.3.3 Also refer to circulars 50102 and 50118.

8.4 CLEARANCE MARKS

- 8.4.1 Clearance marks are placed between converging tracks to indicate where rail vehicles may safely pass.
- 8.4.2 The track personnel are responsible for providing and placing clearance marks.
- 8.4.3 Clearance marks must be at least 1m in length and must be painted white. Scrapped concrete sleepers may, where practical, be used for this purpose. Clearance markers must be installed in such a way that the safety of walk ways are not adversely affected.
- 8.4.4 The webs of adjoining rails opposite the clearance mark as well as the upper surface of the first 'clear' sleepers must be painted white to serve as points of reference.

8.5 USEFUL DIMENSIONS

8.5.1 1 065mm gauge

- 8.5.1.1 The distance between wheel flanges varies from 992mm to 990mm. (The smaller dimension will be changed to 987mm in due course).
- 8.5.1.2 The distance between the two contact points for a new wheel-set on new rails (and on straight track) is 1 137mm. This distance will be changed to 1 151mm in due course.
- 8.5.1.3 Wheel width varies from 127mm to 135mm.
- 8.5.1.4 Wheel diameter can vary from 762mm to 1829mm.
- 8.5.1.5 Wheel flange projection (below rail level) may vary from 35mm to 29mm.
- 8.5.1.6 The average floor height of loaded trucks (above rail level) is 1 030mm.
- 8.5.1.7 The available length in a DZ-truck is 13 800mm and 19 200mm in a DA-truck.
- 8.5.1.8 The distance between rail level and coupler centre line may vary from 910mm to 825mm.

8.5.2 610mm gauge

- 8.5.2.1 Distance between wheel flanges is 540mm.
- 8.5.2.2 Wheel diameter is 805mm.
- 8.5.2.3 The permissible wheel flange projection (below rail level) varies from 32mm to 25mm.
- 8.5.2.4 The average floor height of loaded trucks (above rail level) is 685mm.
- 8.5.2.5 The distance between rail level and coupler centre-line (for empty trucks) is 560mm.

8.5.3 **Permissible axle loads**

- 8.5.3.1 The Assistant General Manager Infrastructure-Maintenance sets the permissible axle loads per line. Allowable axle loads is a function of train speed, the track structure and the bridge structures of the line.

- 8.5.3.2 Before the maximum permissible axle loads on a section is exceeded, the approval of the Assistant General Manager (Infrastructure-Maintenance) must first be obtained.

CHAPTER 9

ASSOCIATED WORKS

9.0 TRACK SIGNS

Track signs must not foul the structure gauge and should, if possible, be placed further than the minimum distance from the centre line of the track.

9.1 GRADE AND KILOMETRE POSTS

9.1.1. Grade and kilometre posts should preferably be placed on the left-hand side of the line facing in the direction of increasing kilometre distance. Grade posts should be placed so that the figures can be seen by the driver of a locomotive. Posts should be placed approximately 3m from the centre line of the outermost track.

9.1.2. Where the 'Track Warrant' system is in use, kilometre posts must be maintained. Both the half and full kilometre posts must be kept clearly visible and readable.

9.1.3. Where lines have been deviated, old mile or kilometre posts must not be disturbed.

9.1.4. Where vertical curves are longer than 120m, grade signs must be placed at the beginning and end of the vertical curve. The arm of the sign pointing to the line gradient must indicate this gradient, and the arm pointing to the vertical curve must be marked with a curved line indicating the direction of the curve.

9.2 PERMANENT SPEED RESTRICTION BOARDS

9.2.1 The fronts of the boards must be painted reflective yellow and indicate the permitted speed in black figures. Where there is doubt in regard to which track a board refers to, a black arrow pointing to the relevant track must be painted on the board. The back of the board must be painted reflective white, indicating the end of the speed restriction in the opposite direction. Where the back of a board cannot be clearly seen, it must be painted black and an additional (white) cancellation board must be provided.

9.2.2 Speed restriction boards must be erected as follows:

9.2.2.1 Different methods of displaying track signage (e.g. fixing to electrification masts and placing boards on poles next to the track) may not be combined in one specific track section.

9.2.2.2 Sections where a specific method will be applied must be selected in consultation with Operating.

9.2.2.3 On single lines boards may be fixed to masts on the left or right hand side of the track section .

9.2.2.4 On double lines, boards must be displayed on both sides of the track section and fixed to masts or poles, where no masts exist.

9.2.2.5 Boards must be fixed to the nearest electrification mast and at least 30m from where the speed restriction begins.

9.2.2.6 Boards must be fixed between 2m and 3m above rail level.

- 9.2.2.7 Electrical must supervise the fixing process.
- 9.2.3 On sections where boards cannot be fixed to electrification masts, they must be placed 30m before the speed restriction begins and on the right hand side of the track, as seen from approaching trains.
- 9.2.4 Grouping of speed restrictions on curved track over short distances is permissible, provided that the number of grouped curves does not exceed five, the distance over which the speed restriction applies does not exceed two kilometres, the lowest speed of the group is made applicable and speed restriction boards are erected only at each end of the group.
- 9.2.5 Where it is necessary to restrict the speed of trains through a station or a yard, or over a considerable distance, a rectangular notice board which should indicate or describe the extent to which the restriction applies, should be positioned adjacent to the permanent speed restriction board. The face of this notice board must be painted yellow and the back white. All lettering and figuring must be black. The normal cancellation board must be erected at the end of the restricted length.
- 9.2.6 Where turnouts are situated on curves and a speed restriction is necessary or where an unequal split turnout exists in a running line, two speed restriction boards must be erected on the same post 30m from the points. The upper board will indicate the maximum permissible speed over the through line, and the lower board the maximum permissible speed for the turnout. In the case of an equal split turnout in a through line, a single speed restriction board must be erected. In the outgoing direction one board must be provided for each line. The backs of the boards must be painted black.
- 9.2.7 Where permanent speed restriction boards applicable to a station or yard have been erected as laid down in clause 9.2.5 hereof, speed restriction boards for turnouts may be unnecessary.
- 9.2.8 Where it is impractical to place permanent speed restriction boards 30m outside the points or place where the speed restriction begins, the boards should be erected in such a position as to give maximum visibility to the driver of an approaching train.
- 9.2.9 For further details refer to Annexure 10, sheet 1.

9.3 TEMPORARY TRACK SIGNS

- 9.3.1 Temporary speed restriction boards and associated boards indicating the start of the danger zone must comply with Annexure 10, sheet 2 and must be placed as shown in Annexure 10, sheet 3.
- 9.3.2 Except on the Coal Line where speed restrictions of 40 km/h may also be used, speed restrictions of 15, 30, 50 and 65 km/h only may be used.
- 9.3.3 In the case of tandem temporary speed restrictions only 30km/h and 50km/h boards are permitted.
- 9.3.4 When temporary speed restrictions are introduced on curves, cant must be adjusted according to Annexure 9, sheet 4. See clause 13.4.2 for electrified lines.
- 9.3.5 Where tamping machines off-track to enable train crossings or stage in section after work (on off-track platforms), tamping machine warning and crossing boards (see Annexure 10, sheet 2) must be used.
- 9.3.6 When temporary track signs are erected or removed, the train control centre/traffic controller must be informed in writing.

- 9.3.7 Temporary speed restriction boards which apply only during hours of duty must be completely removed at the end of each shift.

9.4 DISTANCE AND WARNING BOARDS

Distance and warning boards must be sited to give maximum visibility to the personnel of approaching trains. They should be approximately at right angles to the track, clear of the structure gauge and at distances as laid down in the rules applicable to the boards concerned.

9.5 WARNING SIGNS AT LEVEL CROSSINGS

- 9.5.1. Road warning signs at level crossings must be in accordance with the code, Signing for Railway Crossings, chapter 7, SARTSM, Vol. 2.
- 9.5.2. Track warning signs at level crossings must be erected in accordance with Clauses 9.2.2 and 9.2.3. The placement of the warning signs relative to the level crossing must be in accordance with Annexure 10 sheet 4.
- 9.5.3. The signs are ineffective if placed too high or not at the correct angle to the road. Their positions should therefore be checked by personal observation.

9.6 LEVEL CROSSINGS

- 9.6.1 Level crossings may not be constructed without the necessary authorisation.
- 9.6.2 At public level crossings, Spoornet is responsible for the condition of the track(s) and the Roads Authority for the condition of roads over the track(s). (Also see clause 9.6.6 and 9.6.7)
- 9.6.3 In the case of pedestrian crossings, private crossings, obligatory private crossings, cattle crossings, unproclaimed or unnumbered public roads or unsurfaced private roads which are not controlled by a roads authority, Spoornet is responsible for the maintenance of the section of road within the right of way.
- 9.6.4 Track at level crossings must be opened up and maintained whenever necessary and at least every two years. Prior arrangements must be made with the Roads Authority.
- 9.6.5 Unobstructed visibility must be maintained for both road and rail traffic at level crossings.
- 9.6.6 Where defects on the road surface at a level crossing are considered dangerous to rail or road traffic and require immediate attention, the Track Inspector (Maintenance Management) must inform the Roads Authority concerned and his controlling office immediately. Only if the Roads Authority is unable to undertake the required repairs without delay, must the Track Inspector (Maintenance Management) arrange for the repairs to be done and inform the Roads Authority as soon as possible thereafter of the remedial action taken.
- 9.6.7 No repairs to the road surface (except emergency work) may be undertaken without suitable prior arrangements. Repairs to the road surface within 3m of the centre line of track may be undertaken by the Road Authorities, provided that the work does not affect the flange ways and that prior arrangements have been made with the Depot Engineer's office. Whenever machinery (as opposed to hand tools) is to be used within 3m of the track centre line, prior arrangements must be made with the Depot Engineer's office.
- 9.6.8 When maintenance to level crossings is to be undertaken, the supervisory personnel must ensure that all relevant parties involved are in attendance. Each party will bear its own costs.

- 9.6.9 When work is carried out on the track at a level crossing, care must be taken to interfere as little as possible with the use of the crossing.
- 9.6.10 Track Inspectors (Maintenance Management) must be supplied with the following information in respect of level crossings:
- Railway route,
 - Kilometre distance,
 - Name and/or number and status of road,
 - Road Authority involved,
 - Grades, office addresses and telephone numbers of personnel directly responsible for maintenance.
- 9.6.11 Roads crossing straight railway tracks should be level with the tops of the rails for a minimum distance of 3m from the outer rails.
- 9.6.12 The gradient of a road crossing a single curved railway track should follow the cant of the track (but not steeper than 1 in 15) for a minimum distance of 3m beyond the rails on both sides of the track.
- 9.6.13 Where a road crosses two or more curved railway tracks, the grading of the road approaches will depend on local conditions, and should be decided upon on site.
- 9.6.14 Notwithstanding the provisions of clauses 9.6.12 and 9.6.13, the grading of a road over a level crossing must be altered to suit road traffic patterns.
- 9.6.15 In no case may the width of the road at any level crossing be less than the width of the road which it serves.
- 9.6.16 Fishplated joints are not permitted on or within 6m of level crossings.
- 9.6.17 New level crossings must not be provided with guard rails. Where guard rails are not necessary at existing level crossings, they must be removed.
- 9.6.18 Timbered or precast concrete decks may be provided as a road surface.
- 9.6.19 The track over level crossings must be laid with rails of at least 48 kg/m and on either timber sleepers with E3131 cast iron chairs or concrete sleepers.
- 9.6.20 If any loaded vehicle comes into contact with a height gauge, the vehicle must not proceed before the load is lowered sufficiently to clear the height gauge.

9.7 SERVICE ROADS

- 9.7.1 Roads for maintenance purposes may be constructed as a working charge. Scrap concrete sleepers may be used for building causeways.
- 9.7.2 The Infrastructure Manager must sanction the construction of bridges, culverts and concrete drains.
- 9.7.3 Service roads must be maintained in good condition.
- 9.7.4 Track personnel may carry out minor repairs.

9.8 FENCING

- 9.8.1 Fences must be built and maintained according to the Spoornet Fencing Strategy. New fences must be as per Annexure 29. Existing 6-wire fences must not be changed to 8-wire fences without approval.

- 9.8.2 Approved pre-fabricated fencing may be used.
- 9.8.3 Fence posts between cattle guards and the main fence must be of 6kg or 8kg standards.
- 9.8.4 Barbed wire must not be used where it may cause injury to persons.
- 9.8.5 Track personnel must close any gate that is found open at private level crossings and report the circumstances to the controlling office.
- 9.8.6 Damage to fences and gates must be reported to Infrastructure Fault Control, giving the names and addresses of the responsible persons whenever possible.

9.9 CATTLE GUARDS

- 9.9.1 Cattle guards must be built to plan type I 124/1. They must be painted white and kept free of silt and vegetation.
- 9.9.2 Only hardwood sleepers may be used under cattle guards.
- 9.9.3 On track-circuited and electrified sections there must be no metallic contact between the cattle guards and the running rails. A minimum clearance of 50mm must be maintained between possible points of contact.

9.10 BEACONS

- 9.10.1 The law provides for severe penalties for interference with any land beacon.
- 9.10.2 Beacons on boundary lines or within the property of Transnet must not be moved or destroyed without the necessary authority.
- 9.10.3 Fence posts or fence anchors must not be placed less than 1m from a beacon. Where practical, fencing at corners should be splayed within the property of Transnet.
- 9.10.4 Excavations must not be closer than 1m to any beacon.

9.11 UNDERGROUND SERVICES

- 9.11.1 Track personnel must be careful not to damage underground services alongside or beneath railway tracks.
- 9.11.2 Care must be exercised when digging in the vicinity of buried electric cable routes. These are indicated by cable markers.
- 9.11.3 Cable markers may not be removed without authorisation.
- 9.11.4 Cables running parallel to the track must not be buried in the formation or ballast without the authority of the Infrastructure Manager.
- 9.11.5 Where there is danger of washouts, cables crossing streams may be buried in the bank behind wing walls and head walls of culverts.
- 9.11.6 Cables must return at right angles to the formation to serve telephones and signals.

- 9.11.7. New cables will be buried between 400mm and 750mm below the ground surface within a 4,5m wide strip along the fence and will be indicated by cable markers approximately 15m apart and fixed to the fence.
- 9.11.8 Pegs must not be driven within the cable reserve. Firebreaks and access roads may be made within the reserve. Scrap concrete sleepers must not be left within the cable reserve.
- 9.11.9 Where cables are required to cross service roads and are to be buried less than 800mm deep, they must be placed in pipes of galvanised iron ducting. At other road crossings the cables will pass through conduits.
- 9.11.10 Cables may be laid where necessary in station areas.
- 9.11.11 If a cable is taken through a tunnel, it must be in a conduit and clear of refuges.

9.12 COMMUNICATION ROUTES

If a telegraph pole is found in an unsafe condition, the Track master must take whatever remedial measures are practical. Unsafe poles, broken or slack wires and exposed underground cables must be reported without delay.

9.13 COMMUNICATIONS

- 9.13.1 Track teams must be supplied with the necessary radios, telephones and special keys to be able to communicate with station personnel, the train control centre or the traffic controller, as the case may be.
- 9.13.2 Track Inspectors must ensure that their personnel can operate the equipment.

9.14 BLASTING

- 9.14.1 When blasting is to be undertaken within 500m of a railway line the Track inspector or his representative must be present and consult with the person responsible for the blasting work. He must carry out instructions in the notice and be prepared to stop trains and effect any repairs to the track which may be necessary.
- 9.14.2 If a Track inspector becomes aware that blasting is to take place within 500m of a railway line and he has not been officially advised, he must investigate and take appropriate measures including the stopping of blasting as he considers necessary to protect the property of Transnet.

9.15 FIRES

- 9.15.1 Track personnel must at all times take effective precautions against the outbreak of fire in accordance with this instruction, the Specification for Track Welding, the Work code for Prevention of Fires and any other relevant instruction.
- 9.15.2 They must assist in extinguishing uncontrolled fires.
- 9.15.3 They must report sparks and cinders coming from locomotives.

9.16 FIREBREAKS

- 9.16.1 The Infrastructure Manager will lay down policy in respect of the removal of flammable material and the provision and maintenance of firebreaks.

- 9.16.2 After a fire has occurred, no work must be done on the firebreak, until the Claims Examiner has completed his investigation.
- 9.16.3 Subject to the statutes of applicable legislation, the necessity for the provision and maintenance of a firebreak outside the boundaries of Transnet is left entirely to the discretion of the owner or occupier of the property.
- 9.16.4 The following precautions must be taken when firebreaks are provided on the property of Transnet:
- 9.16.4.1 A two metre wide strip, within boundary fences, must be cleared by burning. Where burning is impractical or inadvisable, the strips may be scoffed and if necessary mounds may be built across the strips to prevent soil erosion.
- 9.16.4.2 Young trees must be protected from damage. The lower branches of pine trees should be cut off to a height of at least 2,5m as soon as they can stand the cutting.
- 9.16.4.3 Firebreaks must not be burnt on both sides of the railway line at the same time.
- 9.16.4.4 Firebreaks must not be burnt when a strong wind is blowing. Burning must be done on the side of the line from which the wind is blowing and towards the line.
- 9.16.4.5 Employees must not leave the site until the fire is completely extinguished.
- 9.16.4.6 Grass which did not burn when first fired must be burnt as soon as it is sufficiently dry.
- 9.16.4.7 Combustible material adjacent to or under telegraph or telephone lines and cables, must not be burnt if there is a possibility of the fire damaging poles, wires or cables. Grass and other combustible material must be removed and burnt at a safe distance from a pole or cable route.
- 9.16.4.8 Every endeavour must be made to prevent the view of road users being obscured by smoke.
- 9.16.4.9 When firebreaks are burnt, fire beaters must be supplied to each member of the gang.

9.17 PLANTS ON OR NEAR THE PROPERTY OF TRANSNET

- 9.17.1 Vegetation growing on the property of Transnet must be removed or trimmed where it:
- 9.17.1.1 prevents locomotive drivers from obtaining a clear view of track signs, level crossings and/or signals,
- 9.17.1.2 prevents the public from obtaining a clear view of approaching trains at level crossings,
- 9.17.1.3 obstructs the visibility of signals from signal cabins.
- 9.17.2 Where growth obstructing the visibility is situated on adjacent private property, permission must be obtained from the owner to trim or remove the obstruction(s).

9.18 ERADICATION OF NOXIOUS WEEDS

Competent guidance is required with the identification and control of noxious weeds.

9.19 RODENTS

Track personnel must report the presence of animals burrowing in or near the formation, so that steps may be taken for their eradication.

CHAPTER 10

TRACK MATERIAL, TOOLS AND EQUIPMENT

10.0 SAFE KEEPING

- 10.0.1 Track material, tools and equipment must be managed according to the latest manual.
- 10.0.2 Track Masters are responsible for the security of material, tools, and equipment issued to them. When not in use, tools must be kept under lock and key.
- 10.0.3 Track Masters must report any loss of material, tools and equipment. Any theft must be reported to the South African Police Services and Asset Protection Services.
- 10.0.4 Track material must not be left in the section any longer than necessary. It should be stored at an emergency camp or at a depot.
- 10.0.5 Property of Transnet must not be used for private purposes.
- 10.0.6 Track personnel must not buy or borrow any goods or property on behalf of Transnet, nor may they dispose of or lend any goods or property belonging to Transnet without written authority from the Infrastructure Manager.

10.1 STORAGE AND CARE OF MATERIAL

- 10.1.1 Material must be placed clear of the structure gauge, and must not be stacked within 3 metres of the centre line of the track. Stacking methods are described in SI(SMT)16/3/3B of October 1995.
- 10.1.2 To discourage theft, sleepers must be stacked as far away as practical from level crossings and roads.
- 10.1.3 With the exception of wood sleepers, track material should not come into direct contact with ash when stacked.
- 10.1.4 The ground within 6m of a stack of wood sleepers must be cleared of all grass and weeds and the storage area must be well drained.
- 10.1.5 Wood sleepers, irrespective of condition, must be stacked in lots of no more than 50 and in accordance with Annexure 12. Different methods of stacking apply to hardwood sleepers, softwood sleepers and crossing timbers. The stacks must be at least 3m apart.
- 10.1.6 Steel sleepers must be stacked clear of the ground, with alternate layers at right angles to each other. They must be stacked with bottoms facing down, in lots of no more than 100. To prevent the layers from rocking, two sleepers must be nested into one another at both ends of each layer.
- 10.1.7 Rails must be positioned upright on an even bed clear of traction bonds and supported to prevent kinking, bending and twisting.
- 10.1.8 Bags containing rail and sleeper fastenings must be stacked clear of the ground and if possible, under cover. Bolts and nuts must be oiled to prevent rust.

10.2 **STOCKS**

- 10.2.1 Material and tool stock levels will vary according to local conditions and must be approved by the Infrastructure Manager.
- 10.2.2 The Depot Engineer will arrange to order material for planned works and emergencies.
- 10.2.3 When taking over a length of track, the Track master must check the material, tools and equipment taken over by him, and send a list of these to the Depot Engineer's Office.
- 10.2.4 Each Track master must control the material, tools and equipment issued to him and check his stock at least once a month.
- 10.2.5 When a Track master relinquishes a length he must check, the material, tools and equipment on hand, and send a list to the Depot Engineer's office, explaining any discrepancies. A duplicate of this list must be left for the supervisor taking over the length.
- 10.2.6 Wood or steel sleepers or tie bars must be kept for emergencies. Insulation must be maintained on track-circuited lines.
- 10.2.7 Special emergency material and equipment must be provided for tunnels with track slabs. (See circular No. 50271).

10.3 **RELEASED TRACK MATERIAL**

10.3.1 Rails

10.3.1.1 Classification

- 10.3.1.1.1 Used or second hand rails released from the track and to be reconditioned in workshops for re-use must comply with the rail classification requirements in Annexure 15, sheet 2. The class of rail is determined by the lowest classification indicator in this Annexure.
- 10.3.1.1.2 Before rails are removed from the section, they must be cut in accordance with Annexure 15 sheet 3 or longer if need be.
- 10.3.1.1.3 Second hand rails (other than reconditioned rails) may be used in running lines provided that:
- They have been ultrasonically tested and are found to be sound in all respects.
 - They match existing rails for wear or will match after grinding and/or welding.
 - The ends of the rails are cropped, by 300mm, to eliminate the old fishbolt holes.
 - New or pressed to parallel fishplates are used if the joints are not welded.
- 10.3.1.1.4 Rails which are removed from the track because of the existence (or suspected existence) of transverse fissures, piping and rails with rail marks BB COS JAX 2496, 2297, 2497 must not be re-used.
- 10.3.1.1.5 The quality of reconditioned rails is the responsibility of the welding workshops.
- 10.3.1.2 Rails intended for re-use must be transported in the longest possible lengths (or as required by the recipient) and cut accordingly. Depending on their intended future use, rails:
- 10.3.1.2.1 must be cut at every exothermic welded joint - the cut must be made adjacent to the edge of the weld collar.

- 10.3.1.2.2 rails consisting of 12m lengths joined by flash-butt welding must be cut through the flash-butt welded joints.
- 10.3.1.2.3 of 36m or long welded rails must be cut in accordance with Annexure 18, sheet 1.
- 10.3.1.2.4 may be flame cut only when they are released to welding depots for reconditioning or are scrapped.
- 10.3.1.3 Rails not required for re-use must be consigned as instructed by a representative of the Materials Logistics section and as follows:
 - 10.3.1.3.1 No other material may be loaded into trucks with second hand rails.
 - 10.3.1.3.2 The rails loaded into any truck should as far as possible be of the same nominal length. Pieces of rail less than 6,5m long must not be loaded into trucks containing longer rails.
 - 10.3.1.3.3 Scrap rails must be loaded separately.
- 10.3.2 Wood sleepers
Refer to clauses 7.0.3.12 to 7.0.3.14.
- 10.3.3 Steel sleepers
Refer to clauses 7.0.4.6 to 7.0.4.7.
- 10.4 TRACK GAUGES**
 - 10.4.1 Track gauges must be checked every six months. The gauge must be checked against a steel tape, and the bubble adjustment checked by reversing the gauge over two points. Geismar and other special track gauges must be checked every time before being used. Defective gauges must be replaced.
 - 10.4.2 Only insulated types of track gauges may be used on electrified and track-circuited lines.

CHAPTER 11

TROLLEYS AND ON-TRACK MACHINES

11.0 NON SELF-PROPELLED TROLLEYS

- 11.0.1. A non self-propelled trolley is any hand-propelled device designed for the conveyance by rail of workmen, tools, material or equipment and includes push trolleys, trestle trolleys, rail transporters, light rail girders and other light machines or equipment that can easily be removed from the line by hand.
- 11.0.2. The person in charge of a trolley, must be certified competent.
- 11.0.3. The person in charge of a trolley must arrange work so as not to unnecessarily delay trains.
- 11.0.4. When a trolley is carrying a heavy load which cannot be easily removed from the track, permission must first be obtained from the train control centre/traffic controller before the trolley may be placed on a running line. In such a case the person in charge of the trolley must obtain authority for an occupation from the train control centre/traffic-controller before placing the trolley on a running line.
- 11.0.5. Non self-propelled trolleys must not be operated at speeds higher than ordinary walking pace.
- 11.0.6. Before a trolley is used, it must be in a track worthy condition and the full serviceability of the handbrake must be ascertained.
- 11.0.7. The person in charge of a non self-propelled trolley must ensure that the hand-signalmen providing the protection for the trolley, is well conversant with their protection duties and capable of executing them correctly.
- 11.0.8. A trolley must not be hauled or propelled by a train, except in an emergency. See clauses 11.2.8 en 11.2.13.
- 11.0.9. The person in charge of a trolley must have it under control at all times. He must warn personnel not to board a moving trolley from the front or the side and to watch for obstructions that may catch their feet.
- 11.0.10. The number of employees travelling on a trolley must not exceed the actual seating accommodation.
- 11.0.11. Employees must not stand on a trolley whilst it is in motion. This does not apply to employees operating a pump trolley.
- 11.0.12. The maximum load is 1 800kg for broad gauge and 1 400kg for narrow gauge trolleys and trailers.
- 11.0.13. Only trolleys with insulated wheels may be used on track-circuited sections. Insulated trolleys must be periodically tested by Signals.
- 11.0.14. Trolleys not in use must be placed clear of the track structure gauge and adequate precautions must be taken to prevent it from being placed back within the structure gauge by unauthorised persons.

11.0.15. Coupling of trolleys

- 11.0.15.1. Coupling of trolleys is undesirable and should only be done when essential. Not more than two trolleys may be coupled together.
- 11.0.15.2. Two trolleys must not be run independently under the control of one person. They must be securely coupled.

11.0.16. Trolleys, level crossings, bridges and tunnels

- 11.0.16.1. Before attempting to cross a level crossing with a non selfpropelled trolley, the person in charge of that trolley must ensure that the level crossing is clear and that it will remain clear for the safe passing of the trolley and its load.
- 11.0.16.2. Before crossing a bridge by trolley, the person in charge must satisfy himself that a train is not approaching.
- 11.0.16.3. When a trolley is used through a tunnel, the person in charge of the trolley must, in addition to the prescribed protection measures, observe special precautions which are contained in clauses 11.0.1 to 11.0.14.

11.1 **SELF-PROPELLED TROLLEYS**

- 11.1.1. Self-propelled trolleys include motor trolleys and all on-track machines. The operating of self-propelled trolleys, excluding Road-rail vehicles, is covered in the General Trains Working rules/General Appendix.
- 11.1.2. The person in charge of a self-propelled trolley must be in possession of effective means of communication for communicating with the train control centre/train traffic controller.
- 11.1.3. The person in charge of a self-propelled trolley being used on a running line, must be qualified and certificated in train operating as applicable to a train driver and he must be the holder of a valid Road Knowledge Certificate for that section of track.
- 11.1.4. A person must first be afforded an opportunity to re-acquaint himself with a section of line if he hasn't operated, piloted or worked a trolley or on-track machine for a period exceeding 6 months over that section of line. After he has acquainted himself with the section of line and before he is placed in charge of a trolley or on-track machine on that section of line, he must record and certify this acquired familiarity in the road knowledge book.
- 11.1.5. A self-propelled trolley equipped with an approved towage may be used to tow a trailer.
- 11.1.6. Trolleys must be maintained so that the requirements of clause 4.0.2 can be met.
- 11.1.7. The maintenance of each trolley must be entrusted to a specific individual.
- 11.1.8. The monthly inspection of trolleys must be carried out in accordance with MTV-21.
- 11.1.9. Trolleys must be inspected before each trip. An inspection manual is provided in the cabin of each trolley.
- 11.1.10. Trolleys must be fitted with an independent emergency brake.

- 11.1.11. A back marker must be attached to the rear of each trolley and a yellow flashing light must be displayed continuously on its roof while it is operated.
- 11.1.12. A self-propelled trolley runs on a running line as a train and is therefore operated in accordance with the specific train working rules as applicable to the operation of trains.
- 11.1.13. Before attempting to cross a level crossing with a self-propelled trolley, the person in charge of that trolley must ensure that the level crossing is clear and that it will remain clear for the safe passing of the trolley.
- 11.1.14. A self-propelled trolley may only be turned around after authority has been obtained from the train control centre/traffic controller. The trolley must be turned at a safe place which is free from obstructions, preferably on straight sections of track. The person in charge of that trolley must ensure that adequate protection is provided on all running lines of which the structure profile might be fouled during the turning process.
- 11.1.15. When a self-propelled trolley is used, by day or night, on a running line, the headlights of the trolley must be switched on.

11.2 OPERATING OF ROAD-RAIL VEHICLES

- 11.2.1. Before a road-rail vehicle (which can also be classified as an on-track machine) may occupy a running line, that section of line must be clear of trains.
- 11.2.2. For a road-rail vehicle to be used on a running line, the person in charge of that vehicle must be qualified in trains operating as applicable to a train driver and he must be the holder of a valid Road Knowledge Certificate for that section of track.
- 11.2.3. The person in charge of a road-rail vehicle must be in possession of effective means of communication for communicating with the train traffic controller.
- 11.2.4. On sections where Colour Light Signalling or the Radio Train Order system or the Track Warrant system is used, a road-rail vehicle may be placed on, or be taken off a running line, at a level crossing or any other suitable place within that section of track.
- 11.2.5. Before the vehicle is placed on a running line, the person in charge of that vehicle must first obtain authorisation from the train control centre/train traffic controller. In the case of colour light signalling, he must then proceed strictly in accordance with the signal indications whilst in the case of the latter two train operating systems, he must be in possession of a valid token for that section of track. Such a token must be arranged between the train control centre/traffic controller and the person in charge of the road-rail vehicle.
- 11.2.6. In cases of any other trains operating system not mentioned in the preceding clause, the person in charge of the vehicle must obtain a valid token from the station or token-station as the case may be, before he may occupy a running line in that section of track.
- 11.2.7. Every time a road-rail vehicle is placed on a running line, the person in charge must obtain an instruction from the train traffic controller, which must indicate the time at which the road-rail vehicle must vacate the running line.
- 11.2.8. A road-rail vehicle fitted with an approved coupler may be used to tow a trailer on a running line.

- 11.2.9. A trailer/trolley may not be propelled (as opposed to being towed) except in an emergency, in which case special care must be taken. For this reason, a coupler must also be available on the front of the road-rail vehicle (see clause 11.2.13)
- 11.2.10. When a trailer is towed on a running line by a road-rail vehicle, the total mass of the trailer (inclusive of it's load) may not exceed 95% of the licensed gross vehicle mass of the road-rail vehicle. When the total vehicle mass of a trailer (inclusive of it's load), exceeds 50% of the road-rail vehicle's licensed gross vehicle mass, then the trailer may only be towed by the road-rail vehicle on a running line, provided that the trailer is equipped with a braking system which is operationally integrated with the braking system of the road-rail vehicle.
- 11.2.11. Unless otherwise specified inside the vehicle, the maximum allowable speed for a road-rail vehicle on a running line is 80km/h. The maximum allowable speed for a road-rail vehicle towing a trailer on a running line is 60km/h. Where a road-rail vehicle is used to tow a trailer on a running line of which the gradients are steeper than 1:100, additional safety precautions must be taken and the maximum speed further reduced.
- 11.2.12. A back marker must be attached to the rear of a road-rail vehicle or its trailer and a yellow flashing light must be displayed continuously on its roof while it is operated.
- 11.2.13. An emergency tow bar must be available on every road-rail vehicle at all times. This tow bar must be suitable for either towing or pushing the road-rail vehicle by a locomotive or other rail/road-rail vehicle in the event of an emergency.

11.3 RAIL TRANSPORTERS

- 11.3.1 Rail transporters must be protected and secured in the same manner as non self-propelled trolleys.
- 11.3.2 Loaded rail transporters may only be placed on a running line after authority has been obtained from the train control centre/traffic controller. The train control centre/traffic controller must ensure that the section of line is clear and remain clear of trains until the rail transporters are clear of the track.
- 11.3.3 For economic reasons, rail transporters should not be worked over long distances.
- 11.3.4 No person may ride on rail transporters or on the rails being transported.
- 11.3.5 Rail transporters must be manually propelled at walking pace.
- 11.3.6 On sections with colour light signalling, only insulated rail transporters may be used.
- 11.3.7 When two-axle type rail transporters are used:
- 11.3.7.1 each unit must be examined by the Track master before use, to ensure that it is in working order and that the brakes are operating efficiently.
- 11.3.7.2 the load on a single transporter must not exceed 7 250kg.
- 11.3.7.3 the rail stops provided must be inserted in the cross bearers before the rails are transported.

- 11.3.7.4 on gradients of 1 in 66 and steeper, all units must be equipped with hand brakes. On gradients flatter than 1 in 66, at least one unit in each set must be equipped with hand brakes.
- 11.3.7.5 rails must be centrally loaded on the cross bearer so that the brake handle is easily accessible.
- 11.3.8. Transporting 18m rails
- 11.3.8.1. Two rail transporters must be used at approximately one quarter of the rails' length from each rail end.
- 11.3.8.2. Not more than two layers of rails may be loaded on rail transporters. The rails in the bottom layer must be upright.
- 11.3.9. Transporting 36m rails
- 11.3.9.1. The distance between rail transporters must not exceed 9m and the end overhang must not exceed 4,5m.
- 11.3.9.2. Only one layer of rails may be loaded on rail transporters.
- 11.3.10. One-axle rail transporters
- 11.3.10.1. One rail may be transported at a time.
- 11.3.10.2. The approval of the Depot Engineer must be obtained before rails longer than 158m are transported.
- 11.3.10.3. Transporters must not be more than 15m apart when conveying a rail.
- 11.3.10.4. Four employees with rail tongs must be posted between all adjacent rail transporters, to control the movement of the rail. They must move with the rail and the tongs must be attached to the rail at all times.

11.4 ON-TRACK MACHINES

- 11.4.1 The person in charge (Track inspector or Track master) must have passed the appropriate theoretical and practical examinations and must be certified competent.
- 11.4.2 Where a Track inspector/Track master has not worked in charge of the operation of an on-track machine for a period exceeding 1 year, he must first pass the appropriate practical on site re-test in as far as machine working, safe working responsibility and contract specifications are concerned, before he may be put in control of such an on-track machine.
- 11.4.3 A Track inspector/Track master in charge of an on-track machine must be practically re-tested on site, every 2 years, in so far as the machine working, safe working responsibility and contract specifications for that machine are concerned. The Depot Engineer, in co-operation with the Central Office, must arrange for these tests.

- 11.4.4 On-track machines must be managed by competent engineering personnel.
- 11.4.5 Productivity targets must be set for all on-track machines or groups of machines.
- 11.4.6 The use of these machines must be frequently discussed with all relevant departments.

CHAPTER 12

SIGNALS

12.0 INTRODUCTION

Track personnel must be acquainted with the functions and working of signalling equipment on their sections.

12.1 PROTECTION

When personnel from Track or Signals or Electrical have to work together, the Person in Charge shall decide on who will be responsible for protection when it becomes necessary.

12.2 GENERAL

Special forums must be created at Central Office and at depots to co-ordinate long, medium and short term planning of maintenance activities.

12.3 INSULATING FASTENINGS

All instructions pertaining to the installation of insulating pads and fastenings must be followed implicitly. Care must be taken not to damage insulating materials.

12.4 SIGNALLING EQUIPMENT

- 12.4.1 Track Masters must keep the working parts of signalling equipment clear of obstructions and ensure that the area is well drained.
- 12.4.2 Track personnel must not interfere with signalling equipment (e.g. axle counters, hot box detectors etc) which has been fastened to the track unless they have been trained to maintain or to service it.
- 12.4.3 Trackmasters must ensure that the routes of surface cables are kept clear of long grass and combustible material.
- 12.4.4 Defective signalling equipment must be reported without delay. Also see clauses 6.0.3 and 6.6.1.4.

CHAPTER 13

ELECTRICAL

13.0 DANGER OF COMING IN TO CONTACT WITH ELECTRICAL EQUIPMENT

- 13.0.1 Persons working closer than 3m to live overhead track equipment must be trained to be aware of the dangers involved as well as in the safe working procedures to be applied and the clearance distances they should observe. (Courses PWP 1 and PWP 2 are available).
- 13.0.2 All electrical equipment and all electric wires may be live and dangerous and must not be touched. Even loose or broken wires lying on the ground may still be live and must not be approached.
- 13.0.3 No person may climb any pole or structure which supports live overhead wires or electrical equipment.
- 13.0.4 No person may climb, ride or work on the roof or on top of any load or equipment carried on any rail or road vehicle (or any machine) under live overhead equipment.
- 13.0.5 Track personnel working on, above or near the track must take precautions to prevent tools, plant or any implements coming into contact with any portion of the overhead equipment or its connections, or making contact between the traction rail and the signal rail simultaneously.

13.1 RESCUE AND TREATMENT OF PERSONS SUFFERING FROM ELECTRIC SHOCK

- 13.1.1 Persons working near high voltage equipment should be trained to apply first aid in the event of shock cases.
- 13.1.2 The procedure to be followed in regard to the rescue and treatment of persons suffering from electric shock is contained in clause 103.9 and Annexure 1.1 of the Electrical Safety Instructions.
- 13.1.3 Personnel trained in the application of artificial respiration are stationed at strategic points throughout electrified areas. The positioning of these artificial respiration posts are indicated by a silver triangular sign with a blue centre.
- 13.1.4 It is recommended that all track personnel employed in areas where high-voltage electrical equipment is installed, take the first opportunity of qualifying in first-aid.

13.2 WORK UNDER "DEAD" CONDITIONS

- 13.2.1 Persons working near high voltage equipment must be aware of what work must be done under dead conditions, i.e. within a siding or under the cover of a work permit.
- 13.2.2 The responsible person in charge of work near high voltage equipment must understand and follow the correct procedures with regard to work permits.

13.3 WORK WHICH MAY BE DONE WHILE ELECTRICAL EQUIPMENT IS “LIVE” AND THE PRECAUTIONS TO BE TAKEN

- 13.3.1 Persons working near live high voltage equipment must be aware of the dangers and implement the necessary precautions.
- 13.3.2 Specific precautions are covered in the training courses PWP 1 and PWP 2 and are required for:
 - 13.3.2.1 Handling of rigid material and wires.
 - 13.3.2.2 Erecting of poles.
 - 13.3.2.3 Use of cranes and machinery.
 - 13.3.2.4 Use of measuring devices.
 - 13.3.2.5 Work on the outside of rolling stock.
 - 13.3.2.6 Handling of tarpaulins and
 - 13.3.2.7 supervision of contractors.
- 13.3.3 The electrical officer (in charge) must always be consulted on all these matters.

13.4 TRACK/MAST ALIGNMENT

- 13.4.1 Reference plates on electrification masts should be used to record the correct mast to rail distance. Track personnel must maintain the track in its correct alignment.
- 13.4.2 Before a track in an electrified section is lifted, lowered or slewed, or before the cant is altered, the responsible electrical officer or his authorised deputy must be notified.

13.5 TRACTION RETURN RAIL CIRCUIT

- 13.5.1 General caution
 - 13.5.1.1 Unauthorised alterations to the traction bonding can result in high voltages which will be dangerous to personnel working on or near the track.
 - 13.5.1.2 Connecting bonds must not be tampered with or disconnected. They must be kept clear of ballast, metal objects and tools. Track personnel must report any defect of or damage to electrical track equipment.
- 13.5.2 Rail bonds
 - 13.5.2.1 A traction rail-to-rail joint bond consists of a length of bare flexible cable fixed to each rail at a joint.
 - 13.5.2.2 Parallel tracks are connected at intervals by cross bonds.
 - 13.5.2.3 On electrified sections the mast to rail bonds are part of the return circuit and must not be disconnected by unauthorised personnel, otherwise dangerous conditions may result.

13.5.3 Other bonds

- 13.5.3.1 These bonds (or parts of them) are normally painted red (except stray current drainage connectors - which are blue, and impedance bonds - which are not painted).
- 13.5.3.2 A spark gap, consisting of a red-painted dome bolted to a flat steel base plate, occurs at numerous points along an electrified line, (e.g. at steel footbridges, road bridges, water columns, goods sheds, station roof structures and certain traction masts). Spark gaps are connected to structures and to the traction rail by means of bonds.
- 13.5.3.3 At all substations large conductors connect the power supply to the rails.
- 13.5.3.4 On some AC-electrified sections the booster transformer's return conductor is carried on the track equipment masts on insulators and is connected to the rail at intervals of about 4km.
- 13.5.3.5 Stray current drainage connections connect buried pipes and other services to the negative return for electrical protection purposes.
- 13.5.3.6 Impedance bonds for signalling purposes are sometimes provided on electrified tracks. They are part of the traction return circuit.

13.5.4 Breaking of track circuits

- 13.5.4.1 No work on the track which involves interference with the traction return rail circuit either by cutting or removing the rails, or by removal of bonds may be done unless Electrical is consulted. Electrical will take such precautions as may be necessary to ensure continuity of the return circuit before permitting the work to commence. Track personnel who have been suitably instructed may apply approved jumpers as permitted in clause 2.13.7 and described herein.
- 13.5.4.2 Should it be necessary to break the track or disconnect any type of bond, the Depot Engineer or his authorised Electrical deputy, must be advised in advance of this intention. Such work must not be started until an authorised employee of Electrical is available to supervise the work, or until this employee indicates that the work may proceed.
- 13.5.4.3 Because of the danger of electric shock on electrified sections, electrical continuity must first be provided. Electrical continuity is provided by means of a jumper cable between broken or fishplated rail ends, or by means of two jumper cables connecting the two ends of the closure rail to the running rail. It must be ensured that the jumper cables remain tight, because the return current can be lethal. (See Annexure 20).
- 13.5.4.4 In emergencies, if no representatives from Electrical or Signals are available or can be consulted, temporary electrical continuity jumper cables must be fixed across the break where a rail has broken, where fishplates or track bonds must be removed or where a closure must be inserted. This must be done strictly in accordance with Annexure 20. Also see clause 2.13.6. and 2.13.7.

13.6 **PREVENTION OF STRAY RETURN CURRENTS**

- 13.6.1 Metallic objects must not be placed in contact with points rods, track equipment structures or any other metal structure attached to the running rails.
- 13.6.2 No metallic object or equipment in contact with the ground, e.g. fences, water pipes, etc. may be attached or connected to the overhead track equipment structures, to any metallic equipment associated with the track or to the rails.

CHAPTER 14

TRAIN OPERATING

14.0 INTRODUCTION

In order to render a safe, affordable, dependable and predictable service, track personnel must ensure that the railway lines and associated works are always safe for the passage of trains.

14.1 PLANNING

14.1.1 Infrastructure must establish forums to co-ordinate short, medium and long term planning with interested departments.

14.1.2 Over exploitation must be prevented and the creation of excess capacity must not be allowed.

14.2 IRREGULARITIES/DEFECTS

14.2.1 Prompt action must be taken by track personnel when irregularities / defects are reported to them or come to their attention, in order to ensure the safety of trains, of clients, the public, co-workers and the environment.

14.2.2 The procedures for reporting/recording of irregularities/defects must be followed conscientiously by all concerned.

14.3 COMMUNICATION

Regular communication is necessary between track personnel and other employees involved with the running of trains. Track supervisors must ensure that adequate communication is maintained.

CHAPTER 15

WORK CODES TO BE USED BY TRACK PERSONNEL

15.0 BALLAST

- 15.0.1 Machine cleaning.
- 15.0.2 Hand cleaning

15.1 INSULATING JOINTS

- 15.1.1 Positioning and maintenance.
- 15.1.2 In-situ assembly

15.2 BRIDGES AND CULVERTS

- 15.2.1 Bridge code.
- 15.2.2 Handbook.
- 15.2.3 Inspection.

15.3 EARTHWORKS, FORMATION AND DRAINAGE

- 15.3.1 Inspection. *
- 15.3.2 Drainage maintenance *

15.4 CIVIL ENGINEERING

- 15.4.1 Handbook (greenbook).

15.5 TRACK

- 15.5.1 Geometric evaluation.
- 15.5.2 Manual for Managing Track Material.
- 15.5.3 Evaluation of material and track condition.
- 15.5.4 Tamping.
- 15.5.5 Screening machine.

15.6 RAILS

- 15.6.1 Repair of breaks.
- 15.6.2 Classification (ANNEXURE 15 Sheet 1, 2 and 3)
- 15.6.3 Destressing.
- 15.6.4 Welding.
- 15.6.5 Ultrasonic and X-ray inspections.

15.7 SIGNS, LEVEL CROSSINGS AND FENCES

- 15.7.1 Inspection

15.8 **TURNOUTS, SLIPS AND DIAMOND CROSSINGS**

- 15.8.1 Construction manual.
- 15.8.2 Inspection.
- 15.8.3 Tamping.
- 15.8.4 Welding.
- 15.8.5 Condition evaluation.

15.9 **CLEARANCES**

- 15.9.1 Inspection.

* In Process

CHAPTER 16

DECISION MODELS/GUIDELINES TO BE USED BY TRACK PERSONNEL

16.0 BALLAST

16.0.1 Determining cleaning priorities.

16.1 CONCRETE SLEEPERS

16.1.1 Treatment of alkaline aggregate reaction.

16.1.2 Replacing of pads.

16.2 TRACK

16.0.1 Determining of tamping cycles.

16.3 RAILS

16.3.1 Rail usage.

16.3.2 Re-use of second hand rails.

16.3.3 Workshop re-profiling.

16.3.4 In-track re-profiling.

16.3.5 Life of rails.

16.3.6 Destressing.

16.3.7 Replacing.

16.3.8 Transposing.

16.4 Set Maintenance Model

CHAPTER 17

RAIL / WHEEL INTERACTION

17.0 INTRODUCTION

- 17.0.1 As a result of the complex nature and high cost attributable thereto, the management of rail / wheel interaction has been placed under the joint management of senior Rolling Stock and Infrastructure personnel.
- 17.0.2 This chapter must be read in conjunction with relevant clauses in other chapters of this manual.
- 17.0.3 A few of the factors that influence rail / wheel interaction are briefly discussed in this chapter.

17.1 GEOMETRY

17.1.1 General

An improvement in the condition of track geometry will improve bogie tracking and will reduce the long term costs associated with the maintenance and relaying of the track.

17.1.2 Ballast

The dimensions shown in **Annexure 4** must be regarded as a minimum for critical points, such as the high legs of sharp curves, on bridges, tunnel entrances and sags of vertical curves.

17.1.3 Superelevation / cant

To reduce unbalanced lateral forces that affect the track structure, it is necessary to apply superelevation to the track. It must be applied in accordance with **Annexure 9, sheet 4** and **clause 4.1.4**.

17.1.4 Gauge

The tracking ability of bogies is reduced exponentially as gauge (due to wear) increases. Action must thus be taken well before maximum allowable gauge is reached. See clause 4.1.3

17.2 LUBRICATION

Lubrication is successful when the gauge corner of the high leg is sufficiently covered with an even layer of grease throughout the curve so that the rate at which rail side-wear occurs is reduced and that it takes place evenly over the whole length of a curve.

17.3 TRACKING

- 17.3.1 As vertical and horizontal irregularities are the main cause of bogie oscillation, special attention must be given to joint maintenance and all work must be performed in accordance with the latest work codes.
- 17.3.2 Forces transmitted to the track by rolling stock must be measured regularly when high rail wear and bogie oscillation occurs.

17.4 MOTIVE POWER AND SPEED

Although dynamic forces decrease as train speed is reduced, longitudinal forces transmitted to the track structure by locomotives are increased. Speed restrictions must be managed accordingly.

17.5 PROFILING

17.5.1 Rail profiling reduces surface defects and improves bogie tracking which in turn reduces flange contact and internal rail stresses.

17.5.2 A dramatic increase in rail life can be achieved when rail profiling, track geometry, lubrication, tracking and speed are managed optimally.

17.5.3 The rail profiling process is complex and must be managed by experts in this field. The latest decision guidelines / models must be used.

CHAPTER 18

PRIVATE SIDINGS

18.0 BACKGROUND

18.0.1 Seventy percent of Spoornet's income can be linked directly to private sidings. The service to these important clients must be managed accordingly.

18.1 INTRODUCTION

18.1.1 Engineers and Engineering Technicians must acquaint themselves with the latest Manual for the **Provision and Maintenance of Private Sidings**.

18.1.2 Track Inspectors concerned with private sidings, must acquaint themselves with **part B** of the document and must be enabled to deliver the required level of service.

18.2 DEFINITIONS

18.2.1 A private siding is a railway track owned by the local authority, a company or a private person and is connected to track of Spoornet or the SARCC.

18.2.2 A siding is that portion of a private siding which is situated on land belonging to Spoornet or the SARCC.

18.2.3 A siding extension is that portion of a private siding which is situated on land not belonging to Spoornet or the SARCC.

18.3 AGREEMENTS

18.3.1 Each private siding is covered by an agreement between Spoornet and the owner.

18.3.2 Location, ownership as well as construction and maintenance details are shown on the agreement plan which forms part of the private siding agreement.

18.3.3 An agreement between Spoornet and the SARCC is required for private sidings connected to the SARCC's lines.

18.3.4 Track personnel who are involved with private sidings must be aware of the above and act accordingly.

18.4 MAINTENANCE

18.4.1 If the take-off turnout is leased, Spoornet bears the cost of maintenance and the renewal of the turnout.

18.4.2 Where Spoornet is responsible for maintenance, the responsible track personnel must ensure that the private siding is adequately maintained.

18.5 MATERIAL

18.5.1 Private siding owners must provide material for the maintenance of their sidings.

18.5.2 Spoornet will supply track material if it is necessary and can be supplied.

- 18.5.3 Material released from private sidings must be handed over to the siding owner in accordance with the stipulations of the Private Siding Agreement. A receipt is to be obtained and forwarded to the Depot Engineers office for official record keeping.

18.6 EMERGENCY WORK

Track personnel must complete all relevant documentation pertaining to emergency work undertaken on private sidings and forward it to the Depot Engineer's Office.

18.7 INSPECTIONS

- 18.7.1 The inspection of private sidings for renewal of right of access must be undertaken by the Track inspector.
- 18.7.2 Private sidings over which locomotives of Spoornet operate must be inspected annually.
- 18.7.3 Private sidings over which locomotives of Spoornet do not operate must be inspected every five years, prior to the renewal of the private siding agreements, unless -
- 18.7.3.1 Spoornet is relieved of all obligations in respect of any portion of a private siding (this will be shown on the agreement plan);
- 18.7.3.2 a private siding owner furnishes an annual certificate signed by a Professional Engineer that the portion of the private siding not covered by the preceding paragraph is safe for the passage of vehicles, including locomotives, of Spoornet.
- 18.7.4 The track personnel of Spoornet may at all times inspect private sidings to satisfy themselves that they are safe for the passage of trains. Comprehensive inspections must be undertaken in accordance with a pre-determined programme and as far as possible be carried out in co-operation with the siding owner or his representative.

18.8 RAIL WEAR

- 18.8.1 Maximum permissible rail wear is as shown for class C rails in **Annexure 15, sheet 2**.
- 18.8.2 Rails must be replaced when the maximum track gauge is reached and the gauge can not be adjusted.

18.9 SLEEPERS

- 18.9.1 Thosti BBRV, Pandrol (mark 2) and Thosti BBRV, Fist (mark 3) may be used.
- 18.9.2 Concrete sleepers may be used in curves on private sidings as follows:
- 18.9.2.1 In running lines exceeding 1 km in length - minimum radius 240m and in running lines less than 1 km in length - minimum radius 140m.
- 18.9.2.2 In staging and shunting lines, minimum radius 140m.
- 18.9.2.3 On curves of radius less than 200m the appropriate gauge widening must be provided.

CHAPTER 19

RECOMMENDED READING FOR TRACK PERSONNEL

19.0 BOOKS

- 19.0.1 Selig, E.T. and Waters, J.M. (1994). Track Geotechnology and Substructure Management. Thomas Telford Services, London.
- 19.0.2 Esveld, Coenraad (1989). Modern Railway Track. MRT Productions, Germany.

19.1 CONFERENCES

- 19.1.1 Conference papers (1987). Related Problems on Wheel/Rail Interface and Railway Systems Capacity. International Heavy Haul Conference, Perth, Australia.
- 19.1.2 Conference papers (1989). Railways in Action. International Heavy Haul Conference, Brisbane, Australia.
- 19.1.3 Conference papers (1992). Meeting the Challenge of Increased Tonnage. International Heavy Haul Conference. Colorado Springs U.S.A.
- 19.1.4 Conference papers (1993). Efficiency and Safety of Heavy Haul Railways. International Heavy Haul Conference, Beijing, China.

19.2 SIMPOSIUMS, LECTURES AND COURSES

- 19.2.1 Post graduate course (1990). Track Maintenance. University of Pretoria.
- 19.2.2 Symposium (1991). Mechanised Track Maintenance. University of Pretoria.
- 19.2.3 Special post graduate course (1992) Fundamentals of Track Structure Design and Maintenance. University of Pretoria.
- 19.2.4 Special course (1993). Rail/Wheel Interaction. University of Pretoria.
- 19.2.5 Lectures (1999). Introduction to Multi Disciplinary Concepts in Railway Engineering. University of Pretoria.

CHAPTER 20

RESPONSIBILITIES AND WORK METHODS APPLICABLE TO SPECIFIC SECTIONS

INDEX

	<u>Clause</u>	<u>Page</u>	<u>Annexure/Sheet</u>
Absence from section	2.13.14	21	
Accidents	2.13.8	18	
Application of manual	1.1	11	
Assistance	2.13.8.2	19	
Associated publications	1.2	11	
Articles found near the line	2.13.10	21	
Axle loads	8.5.3	59	
Ballast	7.1	54	4
	15.0	82	
	16.0	84	
Battered rails	6.12	47	
Beacons	9.10	64	
Blasting	9.14	65	
Block joints	6.8.2	45	26
	15.1	82	
Bonds	13.5	78	
Books	19.0	89	
Borrow pits	3.1.7	23	
Braces	2.13.3.3	17	
Breaking of the line	2.13.6	18	
Breaking of track circuits	2.13.7	18	
Bridges	3.0	23	6
	3.5	24	8
	15.2	82	
Bridle-locked points	5.5	37	
Broken rails	6.14	48	17
	15.6.1	82	
Call-outs	2.13.5	18	
Cant	4.1.4	30	9/4
Catchwater mounds	3.3	23	
Cattle guards	9.9	64	
Check rails	6.5	40	9/3
Civil Engineering	15.4	82	
Classification of			
lines	1.1.2	11	3/1
rails	10.3.1.1	68	15/1-3
	15.6.2	82	
sleepers	7.0.3.11	52	
	7.0.4.6	53	
Clearance marks	8.4	58	
Clearances	8	56	1
	15.9	83	
Closure rails	6.4	39	
Communication	9.13	65	
Communication routes	9.12	65	
Conferences	19.1	89	
Concrete sleepers	7.0.5	53	11/1-2
	16.1	84	13
Contact wire height	8.2	57	

Continuous rails	6.7	41	
	7.0.6.6	54	
	7.1.2.5	55	
Courses	19.2	89	
Creep	6.9	46	
Culverts	3.0	23	
	3.5	24	
	4.0.5.1	29	
	15.2	82	
Curves	4.1	30	9
Curving and straightening of rails	6.1	38	9/1
Cutting of rails	10.3.1	68	15/3
			18/1
Dangerous substances	2.13.15	21	
Decision models	16	84	
Defects	2.13.9	20	17
	4.0.1.3	27	
	4.0.1.4	27	
Defective rails	6.14	48	17
Derailing devices	6.18	50	
Derailments	2.13.8	18	
Destressing	6.10	46	16/3 - 5
	15.6.3	82	
	16.3.6	84	
Detonators	2.13.2	17	
Diamond crossings	4.0.9	29	25/1
	5	33	
	15.8	83	
Dimensions	8.5	58	
Distance boards	9.4	62	10/1
Double slips	4.0.9	29	25/2
	5	33	
Drainage	3.0	23	
	3.3	23	
	15.3	82	
Earthworks	3.0	23	
	3.1	23	
	15.3	82	
Electrical	13	77	
Equipment	10	67	
Eradication of noxious weeds	9.18	66	
Excavations	3.1	23	
Exothermic welding	6.11	47	
Expansion gaps	6.6.2.1	41	16/1
	6.9.3	46	
Fastenings	7.0.3	51	11
	7.0.4	52	
	7.0.5	53	
Fences	4.0.10	29	
	9.8	63	
Fires	9.15	65	
Fire breaks	9.16	65	
Fishplated joints	6.8.1	44	

Flying gang trolleys	11.0	70	
Flexible point blades	5.2.3	35	
Footplate inspections	4.0.3	28	
Formation	3.0	23	
	3.2	23	4
	15.3	82	
Frogs	5.3	36	
Fouling points	8.1	51	
Gauge	4.1.3	31	1/1-2,5 9/2 - 3
Geometry	4.1	30	
	15.5.1	82	
Goal	2.0	12	
Goods found near the track	2.13.10	21	
Grade posts	9.1	60	10/1
Hand signals	2.13.1.8	17	
Handling of rails	6.0	38	
Height gauge	8.2.4	57	
Height of contact wire	8.2	57	
Hinged point blades	5.2.2	34	
Inquiries	2.13.8.9	20	
Inspection of-			
clearances	4.0.11	30	
diamond crossings	4.0.9	29	
drainage	4.0.6	29	
earthworks	4.0.6	29	
fences	4.0.10	29	
formation	4.0.6	29	
level crossings	4.0.10	29	
private sidings	18.7	88	
signs	4.0.10	29	
slips	4.0.9	29	
structures	4.0.5	29	
track material	4.0.8	29	
turnouts	4.0.9	29	
Insulated joints	6.8.2	45	26
	15.1	82	
Jumper cables	13.5.4	79	20
Junction rails	6.3	39	
Kick-outs	6.7.8	43	
Kilometre posts	9.1	60	10/1
Laying of-			
rails	6.6	40	
continuous rails	6.7	41	
Lectures	19.2	89	
Level crossings	4.0.10	29	10/1
	9.5	62	

	9.6	62	
Life of rails	16.3.5	84	
Loading and unloading	6.0	38	13
Lubrication	6.16	49	19
	17.2	85	
Machines	9.6.7	62	
Maintenance of-			
stock and point rails	5.2	34	
frogs	5.3	36	
private sidings	18.4.2	87	
Manual	1	11	
Marking of ultrasonically detected defects	4.0.7	29	17/5
Material	4.0.8	29	
	10	67	
	13.3	78	
	15.5.2	82	
	15.5.3	82	
Measuring devices	13.3.2	78	
Mismatched rails	6.12	47	
Motor trolley inspections	4.0.2	27	
Motor trolleys	11.1	71	
	11.2	72	
Noxious weeds	9.18	66	
Objectives	2.1	12	
Obstructions	2.13.8	18	
On-track machines	11.4	74	
	15.5.4	82	
	15.5.5	82	
Operating	14	81	
Patrolling	4.0.1	27	
Permissible speed on curves			9/4
Pest control	9.19	66	
Pits	4.0.5.2	29	
Plants	9.17	66	
Platforms	8.0.10	56	1/3
Points boxes	5.6	37	
Points locks and keys	5.4	36	
Poles	8.3.1.2	57	
	13.3.2	78	
Private sidings	18	87	
Productivity	2.1.5	12	
Property	2.13.3.1	17	
	10.0.5	66	
Protection of trains and	2.13.1	16	
safeguarding of employees	2.13.3	17	
	2.13.8	18	
Publications	1.2	11	
Purpose	1.0	11	

Radii of turnouts			24
Rail			
breaks	6.14	48	17
	15.6.1	82	
classification	10.3.1.1	68	15/2
	15.6.2	82	
creep	6.9	46	
curving	6.1	38	
cutting	10.3.1.2	68	18
defects	6.14	48	17
	15.6.1	82	
destressing	6.10	46	
	15.6.3	82	
	16.3.6	84	
girders	3.6.4	25	7/1
joints	6.8	44	
life	16.3.5	84	
lubricators	6.16	49	19
profiles	17.5	86	
replacing	16.3.7	84	
re-profiling	16.3.3	84	
	16.3.4	84	
straightening	6.1	38	
transposing	16.3.8	84	
transporters	11.3	73	
usage	6.2	38	15/2
	16.3.1	84	
	16.3.2	84	
wear	6.15	49	15/2
Rail/wheel interaction	17	85	
Recommended reading	19	89	
Reconditioned rails	6.0.2	38	
Releasements	10.3	68	
Reliable watch	2.13.12	21	
Repair of battered and mismatched rails	6.12	47	
Replacing of rails	16.3.7	84	
Responsibilities of the			
Assistant General Manager	2.2	12	
(Infrastructure-Maintenance)			
Depot Engineer	2.4	13	
Engineering Technician	2.8	15	
Infrastructure Manager	2.3	13	
Maintenance Manager (Track)	2.5	13	
Production Manager (Track)	2.7	14	
Track Inspector (Maintenance Management)	2.5	13	
Technical Manager (Welding)	2.12	16	
Technical Supervisor (Welding)	2.11	16	
Track Inspector (Production)	2.11	16	
Track Manager	2.12	16	
Track Master	2.9	15	
Track personnel (On-track machines)	2.6	14	
Track Welder	2.10	15	
Road-rail vehicles	11.2	72	
Rodents	9.19	66	
Rolling stock dimensions	8.5	58	

Safeguarding of employees	2.13.1	16	
Safety precautions	2.13.3	17	
Safety precautions in station yards	2.13.4	18	
Safety rails	3.5.3	25	6
Security	10.0	67	
Scotch blocks	6.18	50	
Screening machines	7.1.4	55	
	15.5.5	82	
Security of tools, equipment and material	10.0	67	
Service roads	9.7	63	
Signals	12	76	
Signs	4.0.10	29	10
	15.7	82	
Symposiums	19.2	89	
Single slips	5	33	25/3
Slacks, kinks and kick-outs	6.7.8	43	
Sleepers	7.0	51	5
	10.3.2	69	11
	10.3.3	69	12
	16.1	84	8
Slips	4.0.9	29	25/2
	5.0	33	25/3
	15.8	83	
Speed restrictions	9.2	60	9/4
	9.3	61	10
Spiked points	5.7	37	
Splice joints	6.8.3	45	
Steel sleepers	7.0.4	52	11/3
Stock and point rails	5.2	34	
Stocks of material	10.2	68	
Stop blocks	6.17	50	28
Stormy weather	4.0.1.5	27	
Straightening and curving of rails	6.1	38	9/1
Structure gauge	8	56	
Structures	4.0.5	29	
Switch boxes	5.6	37	
Table drains	3.3	23	
Taking over a length	2.13.11	21	
Tamping	7.1.5	55	
	11.4	74	
	15.5.4	82	
	15.8.3	83	
	16.2	84	
Tapes	2.13.7.2	18	
	10.4.1	69	
Temperature	6.6	40	16
	6.7	41	
	6.10	46	
Temporary track signs	9.3	61	10/2
Temporary track support	3.6	25	7
Tolerances for platforms	8.0.9	56	1/3
	8.0.10	56	
Tools and equipment	10.4	69	
Track			
alignment	6.7.8	43	
centres	8.3	57	
circuit bonds	13.5	78	

circuits	2.13.7	18	
condition evaluation	15.5.3	82	
	15.8.5	83	
data	1.2	11	
defects	2.13.9	20	
defect books	2.13.9	20	
gauge and rail wear	4.1.3	31	
			9/2 - 3
gauges	10.4	69	15/1
measuring car	4.0.4	28	
signs	4.0.10	29	10/1
	9.0	60	
	15.7	82	
standards	4.1.1	30	
support	3.6	25	7
Traction return circuit	13.5	78	
Transition curves	4.1.2	31	9/2 - 3
	4.1.4	32	
Transport of rails	6.0	38	
	10.3.1.2	68	
	11.3	73	
Transporters	11.3	73	
Transposing of rails	16.3.8	84	
Trolleys	11	70	
Tumblers	5.5	37	27
	5.6	37	
Tunnels	3.0	23	
	3.4	24	
	4.0.5	29	
	6.6.1.3	40	
	6.7.4.6	42	
Turnouts	4.0.9	29	21 - 23
	5	33	
	15.8	83	
Ultrasonic			
defects			17/5
inspections	4.0.7	29	
	15.6.5	82	
Undercut stock rails	5.2.3	35	
Undercutting and shoring	3.1	23	
Underground services	9.11	64	
Useful dimensions	8.5	58	
Vehicle gauges			2/1-2
Visibility	9.6	62	
Warning boards	9.4	62	10/1
Warning signs at level crossings	9.5	62	10/1
Wear of rails	6.15	49	15/1
Weeds	9.18	66	
Wheel-spin damage	6.13	48	
Whistle boards	15.7	82	10/1

Wood sleepers	7.0.3	51	11/4
Work codes	15	82	
X-ray inspections	4.0.7	29	
	15.6.5	82	

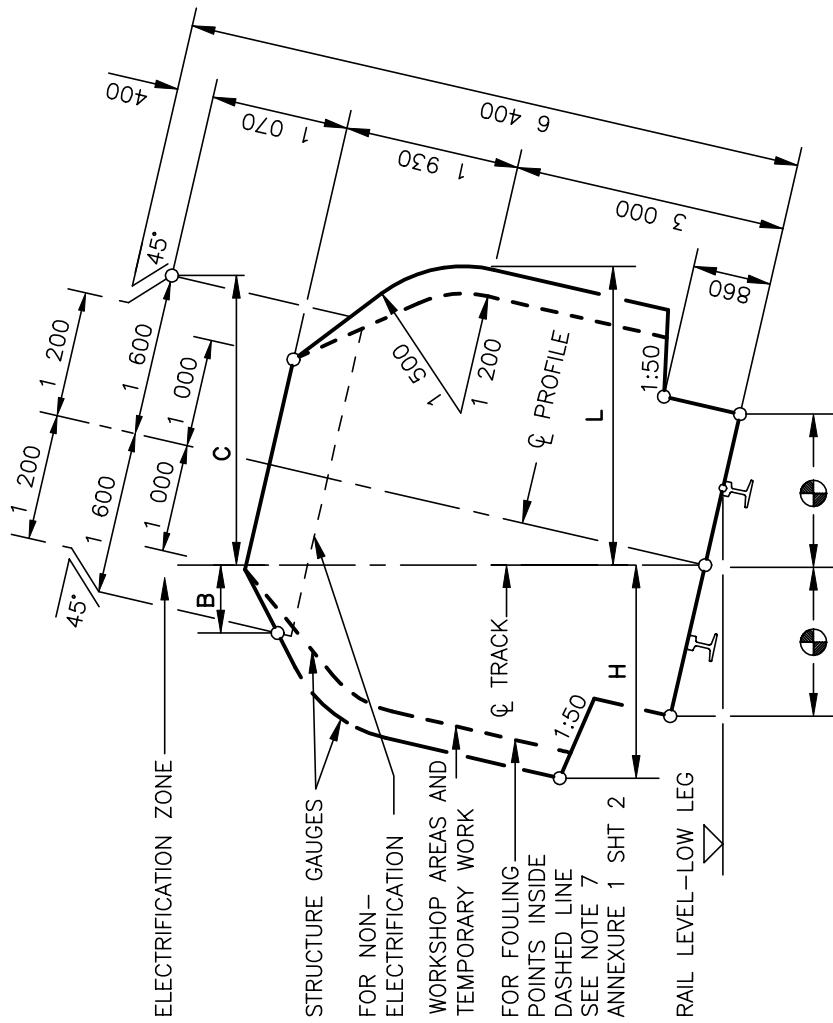

RADIUS (m)	WITH CANT		NO CANT	
	H (mm)	L (mm)	H & L	C (mm)
90	2 730	3 090	2 780	2 100
100	2 700	3 030	2 750	2 050
120	2 650	2 970	2 700	2 010
140	2 620	2 920	2 660	1 990
170	2 590	2 870	2 630	1 970
200	2 570	2 820	2 600	1 950
250	2 550	2 790	2 580	1 920
300	2 540	2 760	2 560	1 900
350	2 530	2 730	2 540	1 890
400	2 520	2 710	2 530	1 875
500	2 510	2 680	2 520	1 850
600	2 500	2 660	2 510	1 830
800	2 490	2 620	2 500	1 790
1 000	2 480	2 600	2 490	1 760
1 200	2 480	2 580	2 490	1 730
1 500	2 480	2 550	2 480	1 700
2 000	2 480	2 500	2 480	1 660
3 000	2 470	2 470	2 470	1 600
>5 000	2 460	2 460	2 460	1 600

REMARKS:

1. H AND B IS THE REQUIRED HORIZONTAL CLEARANCE ON THE OUTSIDE OF THE CURVE BASED ON MINIMUM CANT.
2. L AND C IS THE REQUIRED HORIZONTAL CLEARANCE ON THE INSIDE OF THE CURVE BASED ON MAXIMUM CANT.
3. INTERMEDIATE VALUES MAY BE INTERPOLATED BY THE ENGINEER IN CHARGE.
4. FOR WORKSHOP AREAS AND TEMPORARY WORK, CLEARANCES H AND L MAY BE REDUCED BY 300mm.
5. SEE ANNEXURE 1 SHEET 3 FOR PLATFORM CLEARANCES.
6. ALSO REFER TO REMARKS 4 TO 8 OF ANNEXURE 1 SHEET 2.

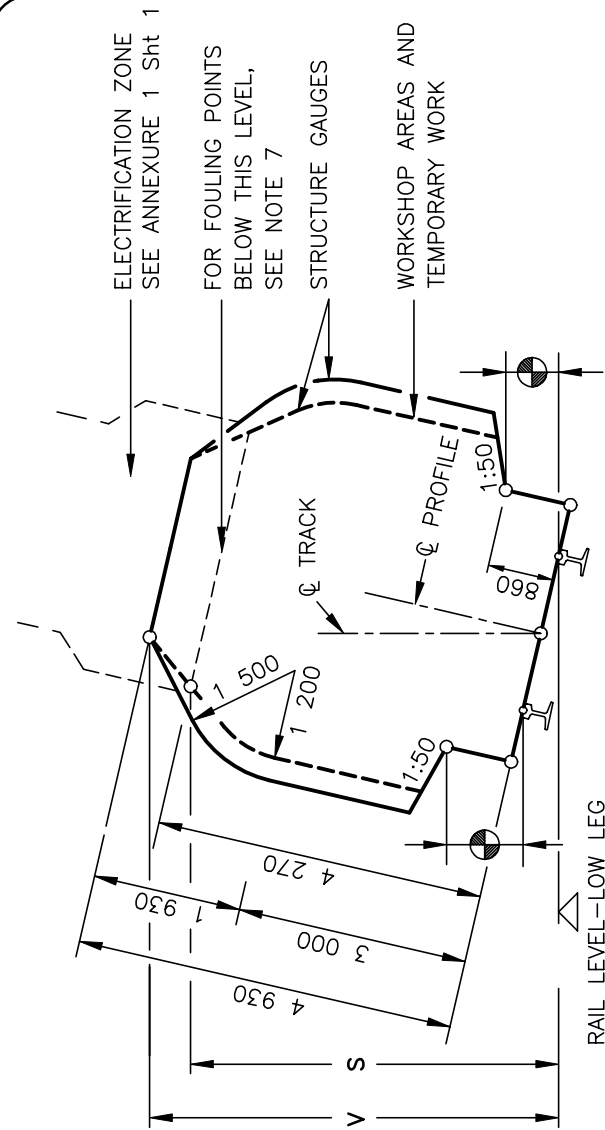

LOCATION	NOT ELECTRIFIED S (mm)	ELECTRIFIED (PRESENT OR FUTURE)	
		3kV & 25kV V (mm)	50kV V (mm)
RADIUS (mm)			
100	4 470	5 050	5 400
300	4 410	5 020	5 370
600	4 370	5 000	5 350
1 000	4 350	4 990	5 340
1 500	4 310	4 960	5 310
2 000	4 290	4 940	5 290
>3 000	4 270	4 930	5 280
* OVER OR NEAR POINTS AND CROSSING IF REQUIRED BY ELECTRICAL IRRESPECTIVE OF RADIUS			
ALL AREAS OTHER THAN THOSE INDICATED BY * BELOW			

REMARKS:

1. V IS THE REQUIRED VERTICAL CLEARANCE EXCEPT WHERE REDUCED CLEARANCE S APPLIES.
2. S IS THE MINIMUM VERTICAL CLEARANCE FOR STRUCTURES AND TEMPORARY WORK OVER NON-ELECTRIFIED LINES.
3. INTERMEDIATE VALUES MAY BE INTERPOLATED BY THE ENGINEER IN CHARGE.
4. FOR APPLICATION AT CURVES
 - 4.1 APPLY INCREASED CLEARANCES FOR CURVES TO POINTS 3m BEYOND THE ENDS OF THE CIRCULAR CURVE.
 - 4.2 REDUCE CLEARANCES AT A UNIFORM RATE OVER THE REMAINDER OF THE TRANSITION CURVE.
 - 4.3 FOR NON-TRANSITIONED CURVES REDUCE AT A UNIFORM RATE OVER A LENGTH OF 15m ALONG STRAIGHTS.
5. NEW STRUCTURES: SEE BRIDGE CODE.
6. TUNNELS: SEE DRAWING BE 82-35.
7. FOULING POINTS: SEE CLAUSE 8.1.
8. CLEARANCES ARE BASED ON 15m BOGIE CENTRES AND 21,2m VEHICLE BODY LENGTH.
9. SEE ANNEXURE 1 SHEET 3 FOR PLATFORM CLEARANCES.

PLATFORMS : TRACK GAUGE 1 065mm

PASSENGERS

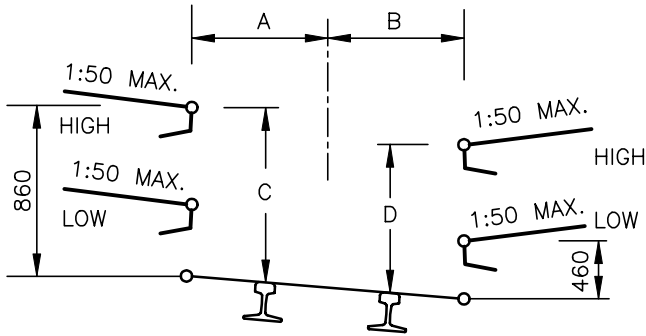

GOODS

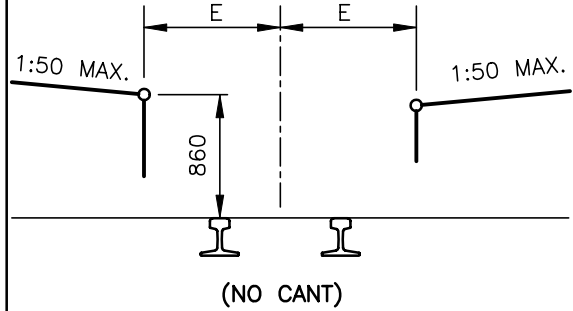

RADIUS (m)	A (mm)	B (mm)	C (mm)	D (mm)	E (mm)
90	1 690	1 820	890	810	1 840
100	1 650	1 790	890	810	1 810
120	1 610	1 740	890	810	1 760
140	1 580	1 700	890	810	1 720
170	1 550	1 660	890	810	1 690
200	1 530	1 630	890	820	1 670
250	1 520	1 600	890	820	1 640
300	1 520	1 580	890	830	1 620
350	1 520	1 560	880	830	1 600
400	1 520	1 550	880	840	1 590
500	1 520	1 540	880	850	1 580
600	1 520	1 530	870	850	1 570
800	1 520	1 520	860	860	1 560
1 200	1 520	1 520	860	860	1 550
2 000	1 520	1 520	860	860	1 540
3 000	1 520	1 520	860	860	1 530
STRAIGHT	1 520	1 520	860	860	1 520

REMARKS:

1. NO CANT TO BE APPLIED EXCEPT WHEN THE GOODS PLATFORM IS ON A RUNNING LINE.
2. INTERMEDIATE VALUES MAY BE INTERPOLATED BY THE ENGINEER IN CHARGE.
3. 8m TO MAIN STATION-BUILDINGS AND 3m TO ALL OTHER STRUCTURES.
4. TOLERANCES : SEE CLAUSE 8.0.10.

STRUCTURES ON PLATFORMS : 1 065mm AND 610mm TRACK GAUGE

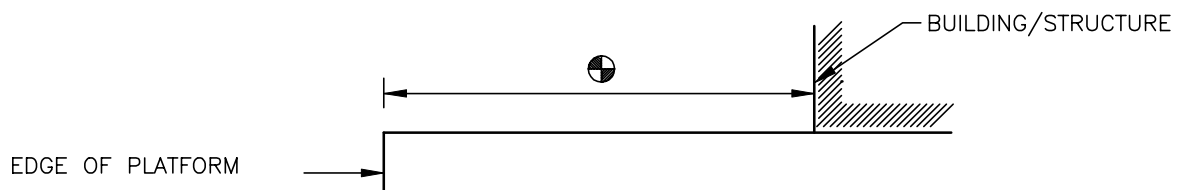

SPECIAL STRUCTURE GAUGE
FOR TRUCK TIPPLER

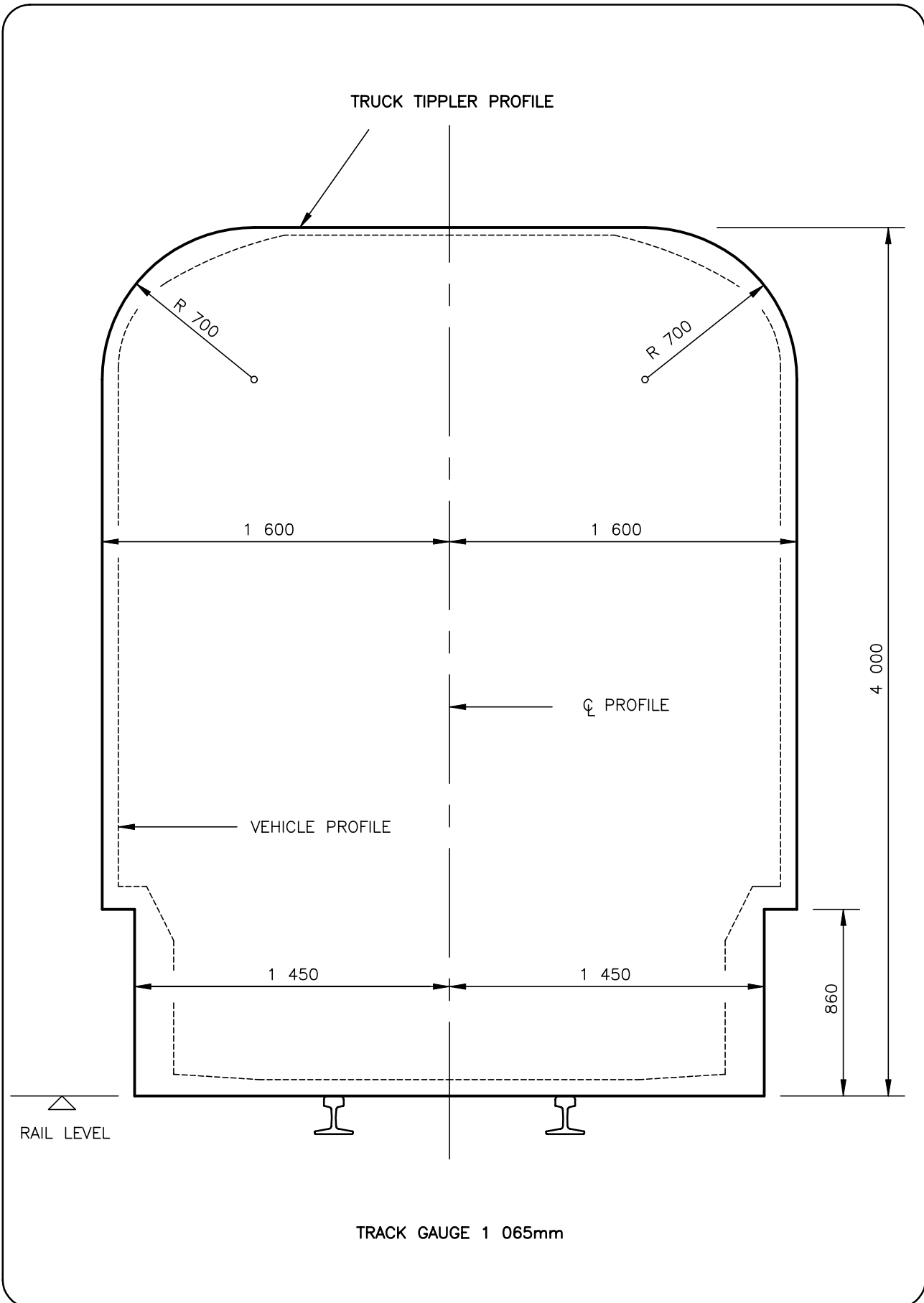

CLEARANCES : 610mm TRACK GAUGE

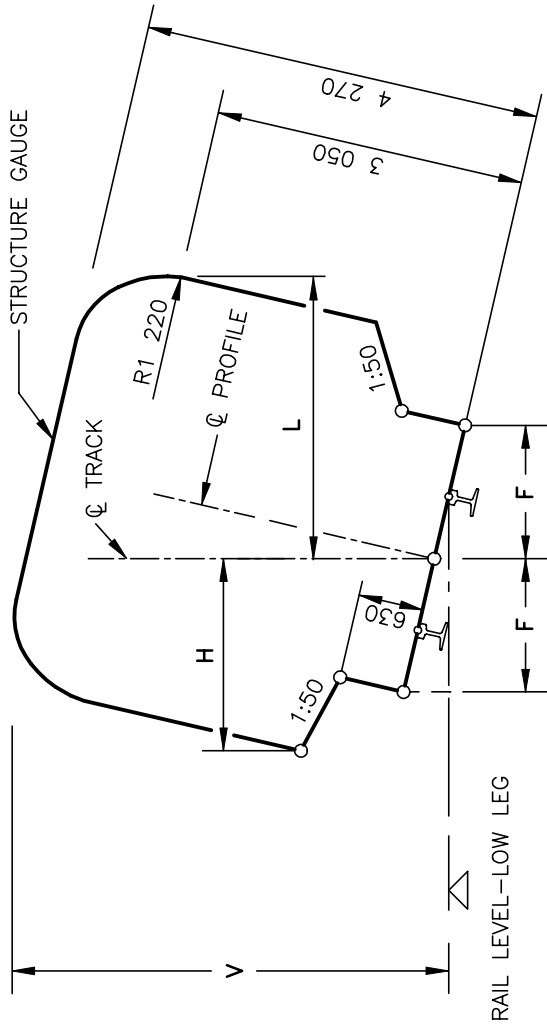

RADIUS (m)	F (mm)
50	1 550
60	1 510
80	1 460
100	1 430
120	1 410
140	1 390
170	1 380
200	1 370
250	1 360
300	1 350
600	1 330
1 000	1 320
>2 000	1 320
STRAIGHT	1 310

RADIUS (m)	WITH CANT		NO CANT		V (mm)
	H (mm)	L (mm)	H & L (mm)	V (mm)	
50	2 370	2 490	2 400	4 320	4 320
70	2 310	2 420	2 330	4 310	4 310
100	2 260	2 370	2 280	4 310	4 310
140	2 220	2 340	2 250	4 310	4 310
200	2 200	2 300	2 220	4 300	4 300
300	2 190	2 270	2 200	4 300	4 300
500	2 180	2 230	2 190	4 290	4 290
700	2 170	2 200	2 180	4 270	4 270
1 000	2 170	2 170	2 170	4 270	4 270
>2 000	2 160	2 160	2 160	4 270	4 270

CLEARANCES

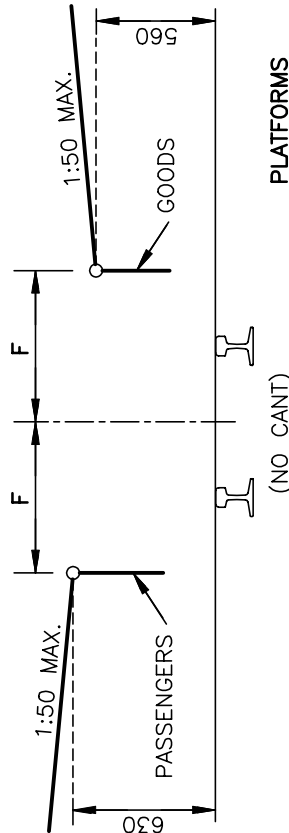

PLATFORMS

REMARKS:

- H IS THE MINIMUM HORIZONTAL CLEARANCE ON THE OUTSIDE OF THE CURVE BASED ON MINIMUM CANT.
- L IS THE MINIMUM HORIZONTAL CLEARANCE ON THE INSIDE OF THE CURVE BASED ON MAXIMUM CANT.
- V IS THE MINIMUM VERTICAL CLEARANCE.
- FOR APPLICATION AT CURVES:
 - 1 APPLY INCREASED CLEARANCES FOR CURVES TO POINTS 2m BEYOND THE ENDS OF THE CIRCULAR CURVE.
 - 2 REDUCE CLEARANCES AT A UNIFORM RATE OVER THE REMAINDER OF THE TRANSITION CURVE.
 - 3 FOR NON-TRANSITIONED CURVES REDUCE AT A UNIFORM RATE OVER A LENGTH OF 18m ALONG STRAIGHTS.
- INTERMEDIATE VALUES MAY BE INTERPOLATED BY THE ENGINEER IN CHARGE.
- ALSO REFER TO REMARKS 5, 6 AND 7 OF ANNEXURE 1 SHEET 2.
- CLEARANCES ARE BASED ON 9 700mm BOGIE CENTRES AND 13 700mm VEHICLE BODY LENGTH.
- SEE ANNEXURE 1 SHEET 3 FOR STRUCTURES ON PLATFORMS.

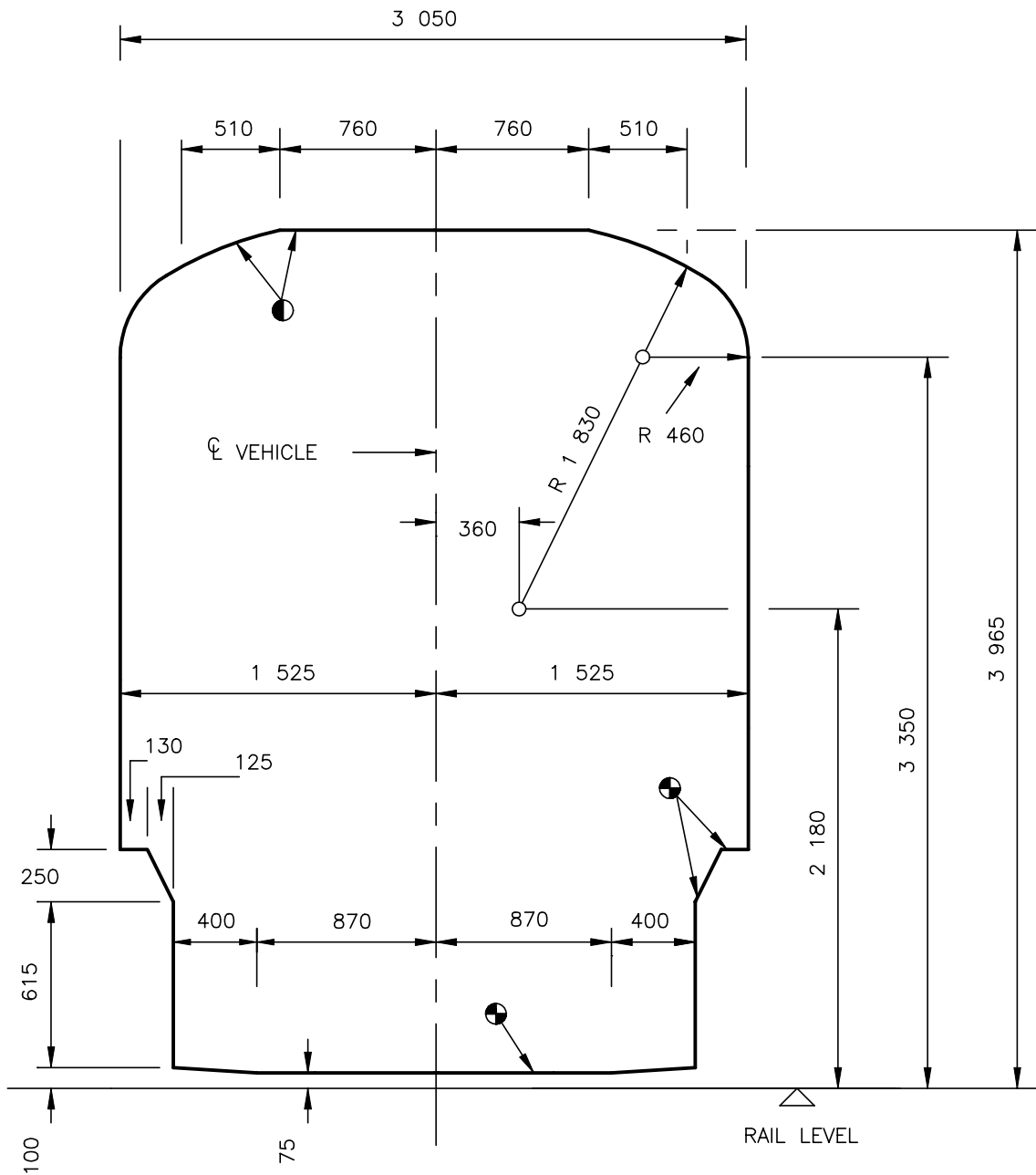

REMARKS:

1. ● WITHOUT LOAD AND WITH NEW TYRES, VEHICLE MUST NOT BE HIGHER THAN THIS OUTLINE.
2. ⊕ WITH FULL LOAD AND WORN TYRES, VEHICLE MUST NOT BE LOWER THAN THIS OUTLINE.

CLASSIFICATION OF RUNNING LINES			TRACK STANDARDS FOR RUNNING LINES			
CLASS OF LINE	MAXIMUM AXLE LOAD (Ton)	GROSS TON PER YEAR (Million)	RAIL TYPE AND MASS	SLEEPER AND SPACING	BALLAST	
					DEPTH (mm)	QUANTITY (m ³ / km)
					CONCRETE	WOOD / STEEL
S	26	–	60kg/m	FY/PY 650mm	300	1 600 –
N1	20	>15	57kg/m	FY/PY/ #700mm	280	1 500 –
N2	20	5–15	48kg/m	P2/F4 STEEL/ 700mm WOOD	200	1 200 1 100
N3	–	<5				

REQUIRES THE PRIOR APPROVAL OF THE ASSISTANT GENERAL MANAGER (INFRASTRUCTURE MAINTENANCE).

REMARKS:

1. ANY DEPARTURE FROM THESE STANDARDS REQUIRE THE APPROVAL OF THE ASSISTANT GENERAL MANAGER (INFRASTRUCTURE MAINTENANCE).
2. CLAUSES 6.2 AND 6.7, AS WELL AS ANNEXURES 4 AND 15 SHEET 2, MUST BE READ TOGETHER WITH THIS TABLE.
3. # P2, F4 AND WOODEN SLEEPERS ARE ALSO ACCEPTABLE. SEE ANNEXURE 4 SHEET 1 FOR BALLAST QUANTITY.

FORMATION AND BALLAST :
MINIMUM REQUIREMENTS

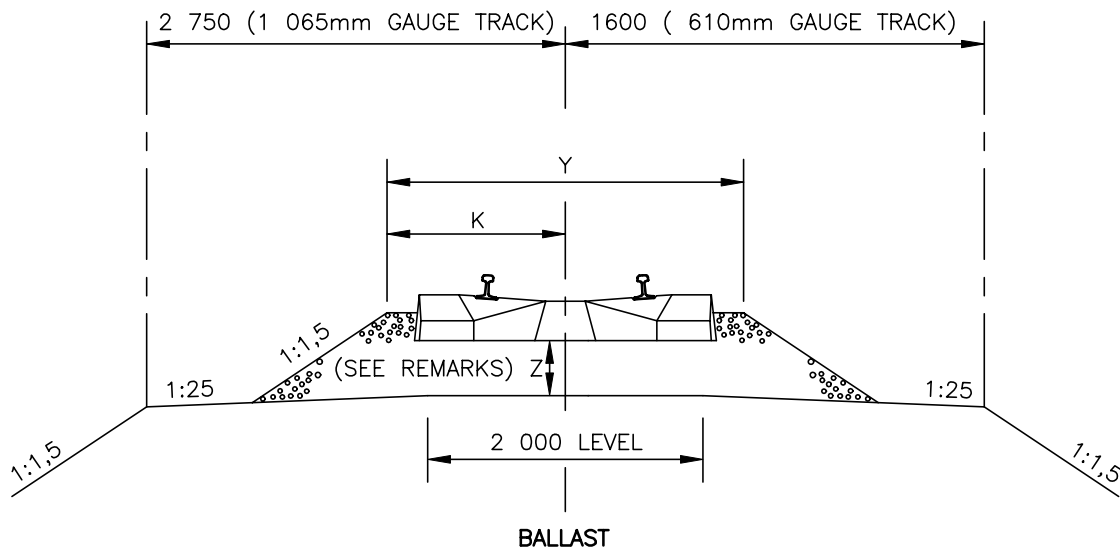
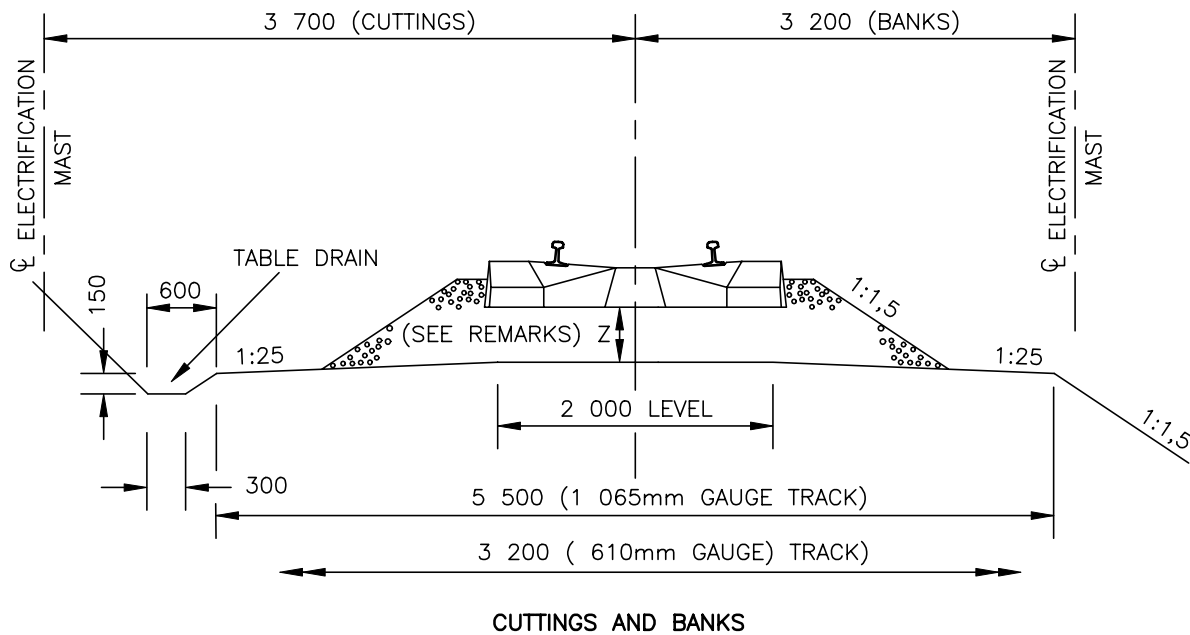

CLASS OF LINE	Z (mm)	Y (mm)	K (mm)	QUANTITY (m ³ /km)		
				PY/FY	P2/F4	WOOD
S	300	2 800	1 400	1 600	—	—
N1	280	2 700	1 350	1 500	1 400	—
N2	200	2 700	1 350	—	1 200	1 100

REMARKS:

1. Z TO BE MEASURED UNDER THE LOW LEG RAIL ON CURVES.
2. DEPTH OF BALLAST (Z) ARE TO BE MEASURED IN THE CONSOLIDATED STATE, THAT IS AFTER 100 000 GROSS TON TRAIN TRAFFIC.

SLEEPER SPACING

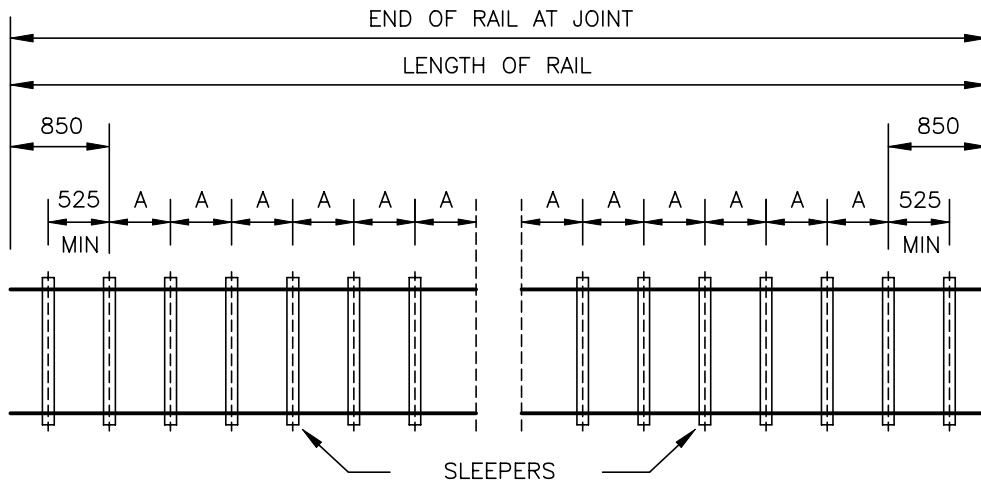

GAUGE 1 065mm

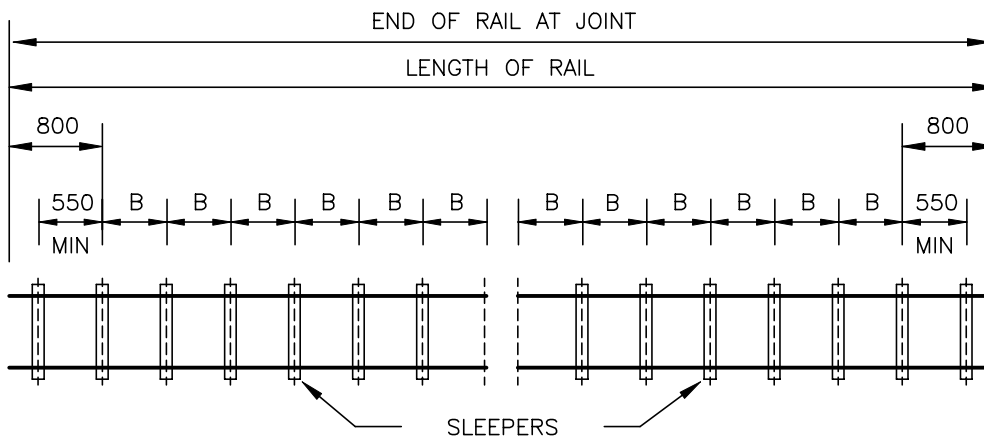

GAUGE 610mm

REMARKS:

1. DISTANCE FROM END OF RAIL TO SECOND SLEEPER SPACING IS FIXED.
2. SLEEPER SPACING FOR SAFETY BARS TO BE THE SAME AS FOR LOCK BARS.

LENGTH OF RAIL	NOMINAL SPACING					
	A = 650mm		A = 700mm		B = 800mm	
	SLEEPERS PER RAIL		SLEEPERS PER RAIL		SLEEPERS PER RAIL	
	RAIL	km	RAIL	km	RAIL	km
36m FOR 1 065mm GAUGE	56	1 555	52	1 444	-	-
CWR FOR 1 065mm GAUGE	-	1 539	-	1 429	-	-
12m FOR 610mm GAUGE	-	-	-	-	16	1 333

SAFETY RAILS FOR BRIDGES

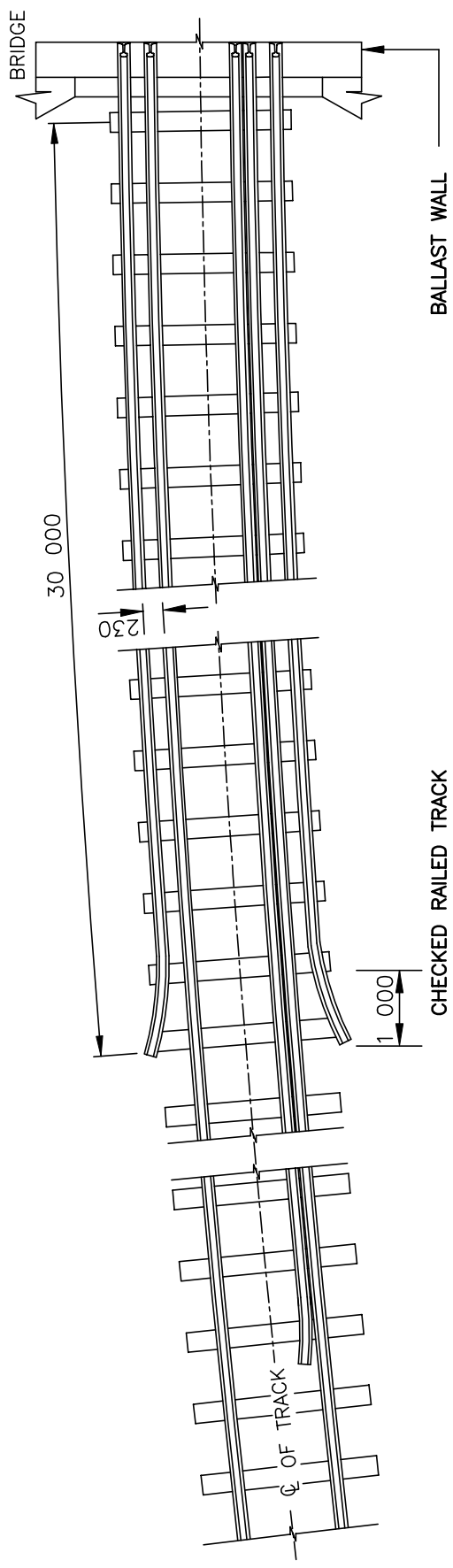
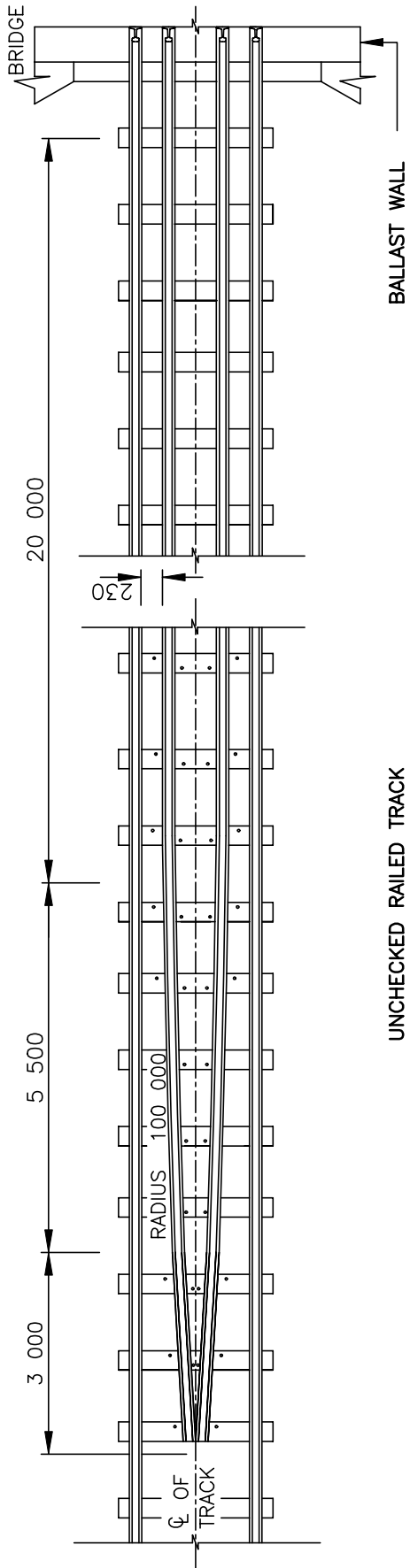

REMARKS:
1. FOR MANUFACTURING DETAILS OF V-PIECE SEE DRAWING TYPE-E-7070.

TEMPORARY TRACK SUPPORT :
RAIL GIRDERS

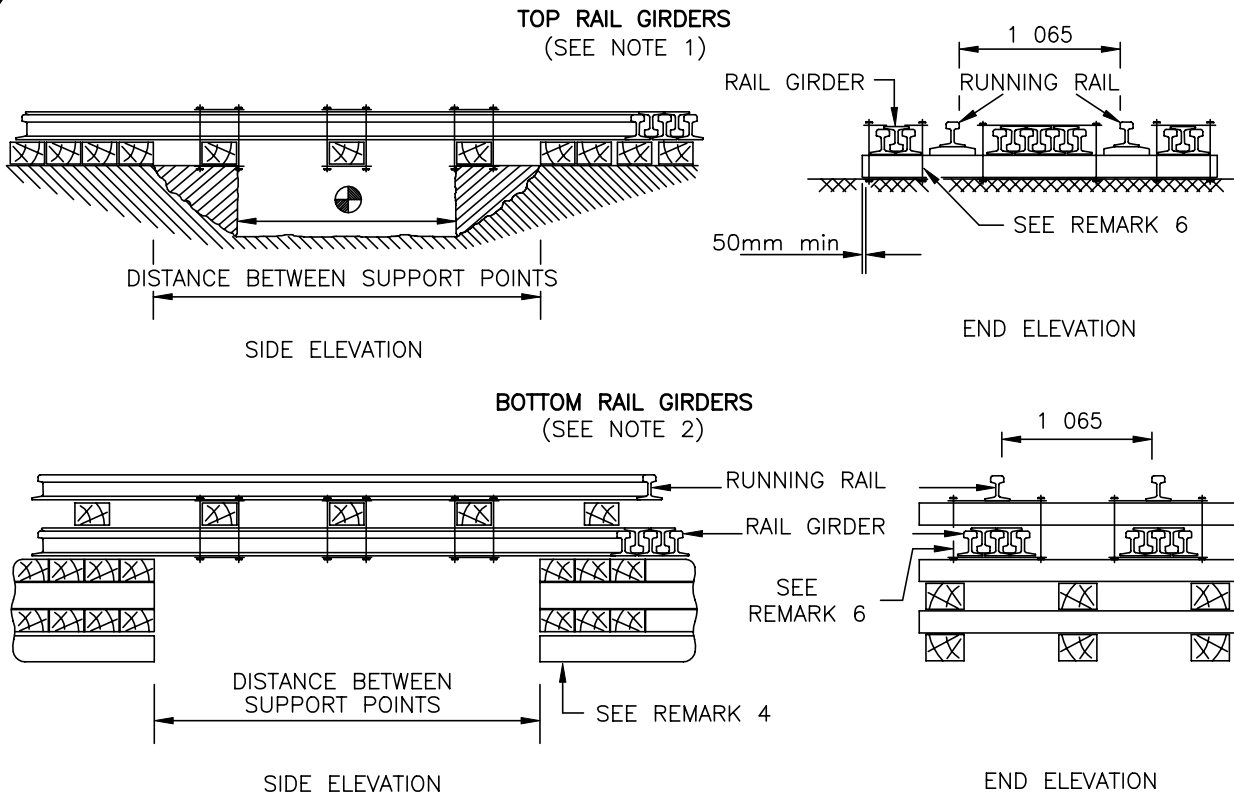

TOP RAIL GIRDERS				BOTTOM RAIL GIRDERS			
DISTANCE BETWEEN SUPPORT POINTS	RAIL GIRDER GROUPS			DISTANCE BETWEEN SUPPORT POINTS	RAIL GIRDER GROUPS		
	30-37kg	40-43kg	48kg		30-37kg	40-43kg	48kg
1,5m	3-5-3	3-5-3	3-5-3	1,5m	5-5	5-5	3-3
2,0m	3-7-3	3-5-3	3-5-3	2,0m	7-7	5-5	3-3
2,5m	5-9-5	3-7-3	3-5-3	2,5m	9-9	7-7	5-5
3,0m	-	5-9-5	3-7-3	3,0m	-	9-9	5-5
3,5m	-	7-9-7	3-7-3	3,5m	-	11-11	7-7
4,0m	-	-	5-9-5	4,0m	-	-	9-9
4,5m	-	-	7-9-7	4,5m	-	-	11-11

REMARKS:

1. READ IN CONJUNCTION WITH CLAUSE 3.6.
2. TEMPORARY TRACK SUPPORTS HAS TO BE APPROVED BY THE DEPOT ENGINEER. IN EACH CASE, THE SUPPORT POINTS HAS TO BE DESIGNED BY A PROFESSIONAL ENGINEER.
3. CHOOSE RAIL GIRDERS TO SUIT REQUIRED DISTANCE BETWEEN SUPPORT POINTS.
4. ONLY ONE TYPE OF RAIL TO BE USED IN RAIL GIRDER.
5. RAILS TO BE CLASS C, 12m OR LONGER WITHOUT WELDED JOINTS.
6. FOR CLAMPS SEE B.E. 7054/1 M.
7. ⊕ WIDTH OF EXCAVATION.
8. CLAMP EVERY SLEEPER ACROSS THE ENTIRE LENGTH OF THE RAIL GIRDER.
9. MIN. OF 4 SLEEPERS ARE REQUIRED TO BE USED AT SUPPORT POINTS.
10. NOT TO BE USED ON LINES CARRYING HEAVY LOADS.

TEMPORARY TRACK SUPPORT :
SLEEPER CRIBS

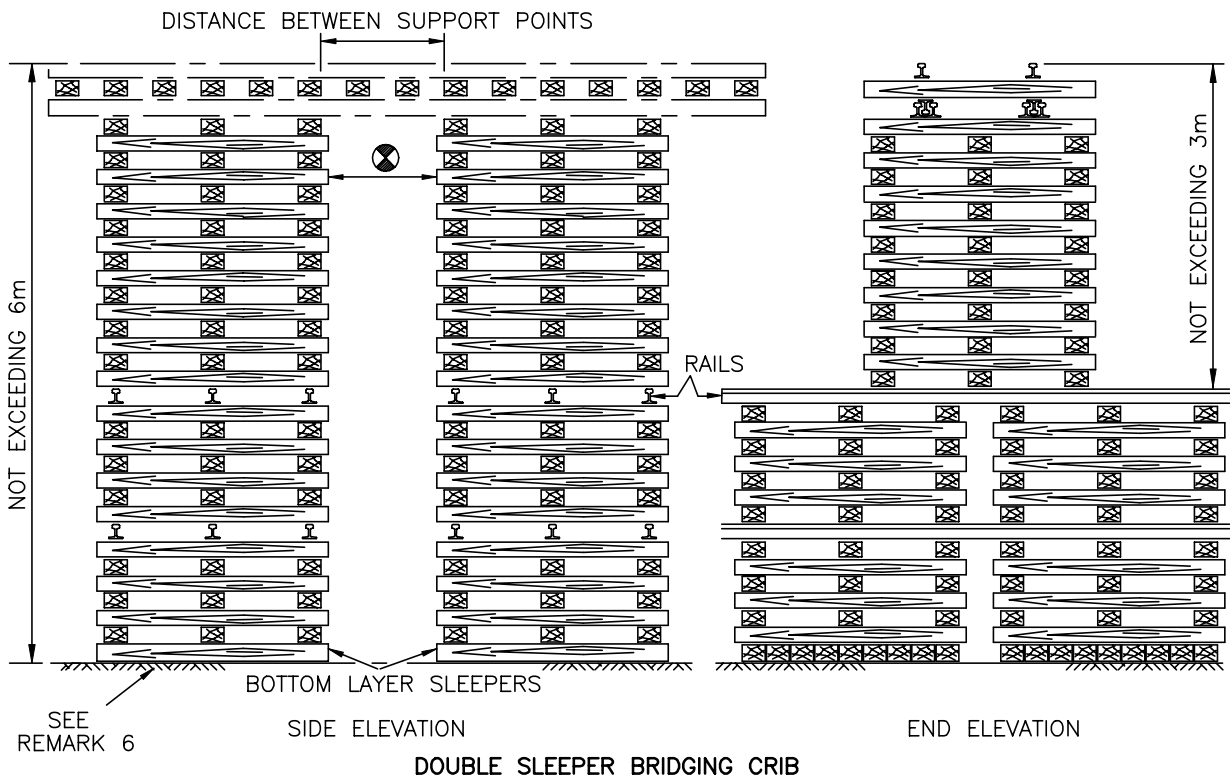
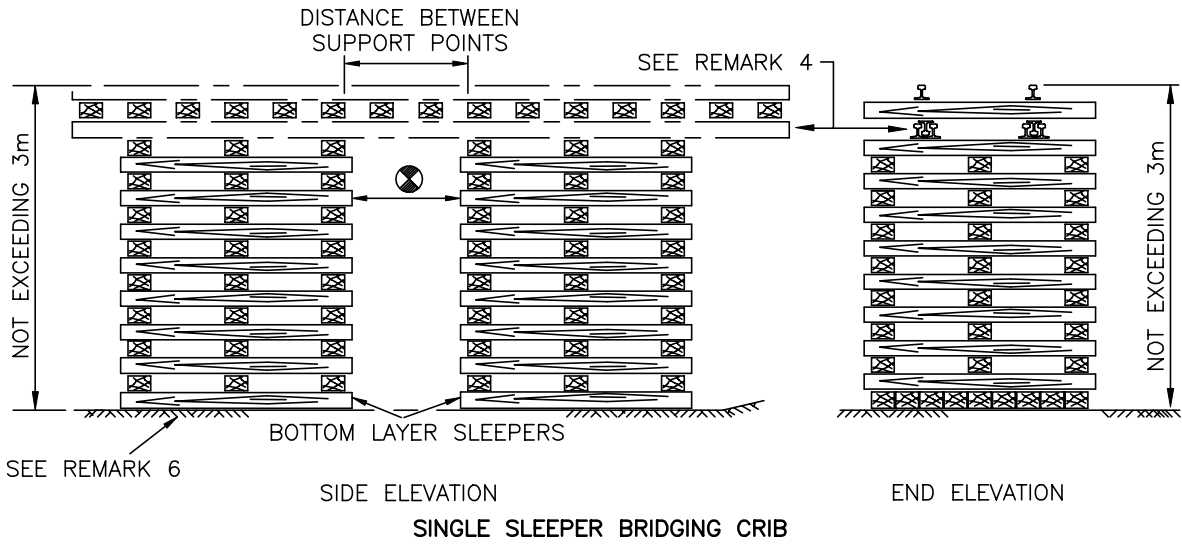

REMARKS:

1. READ IN CONJUNCTION WITH CLAUSE 3.6.
2. ⊗ DENOTES REQUIRED SPAN (SEE ANNEXURE 7 SHT 1).
3. NOT TO BE USED ON LINES CARRYING HEAVY LOADS.
4. FOR BOTTOM RAIL GIRDER SEE ANEXURE 7 SHT 1.
5. IN ALL CASES THE BOTTOM LAYER OF SLEEPERS MUST BE PLACED PARALLEL TO THE TRACK AND CLOSE LAID.
6. A QUALIFIED PROFESSIONAL ENGINEER MUST ENSURE THAT THE SUPERIMPOSED LOAD DOES NOT EXCEED THE BEARING PRESSURE OF THE GROUND.

TEMPORARY TRACK SUPPORT :
BRIDGING CRIBS

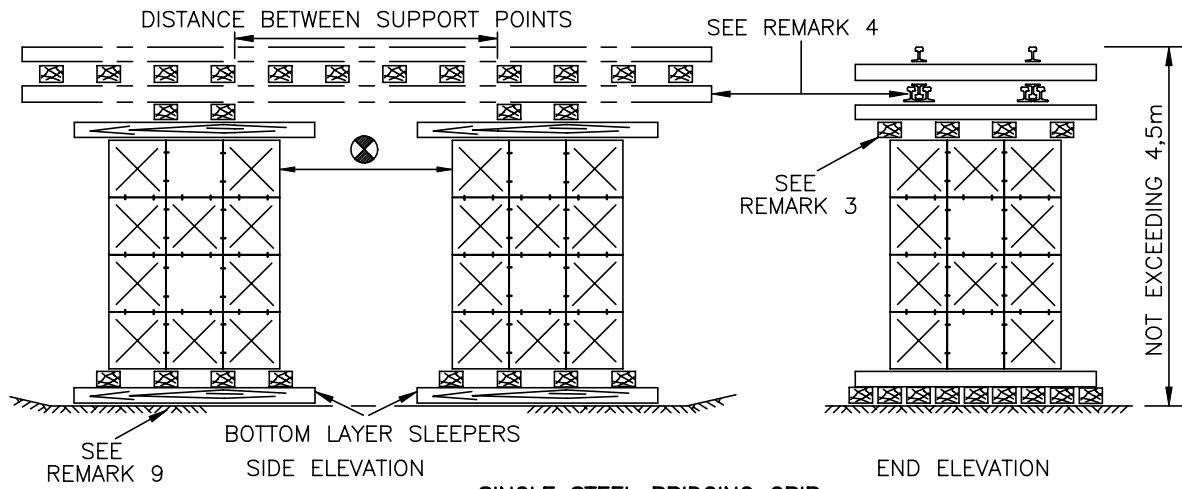

SINGLE STEEL BRIDGING CRIB
(SEE NOTE 5)

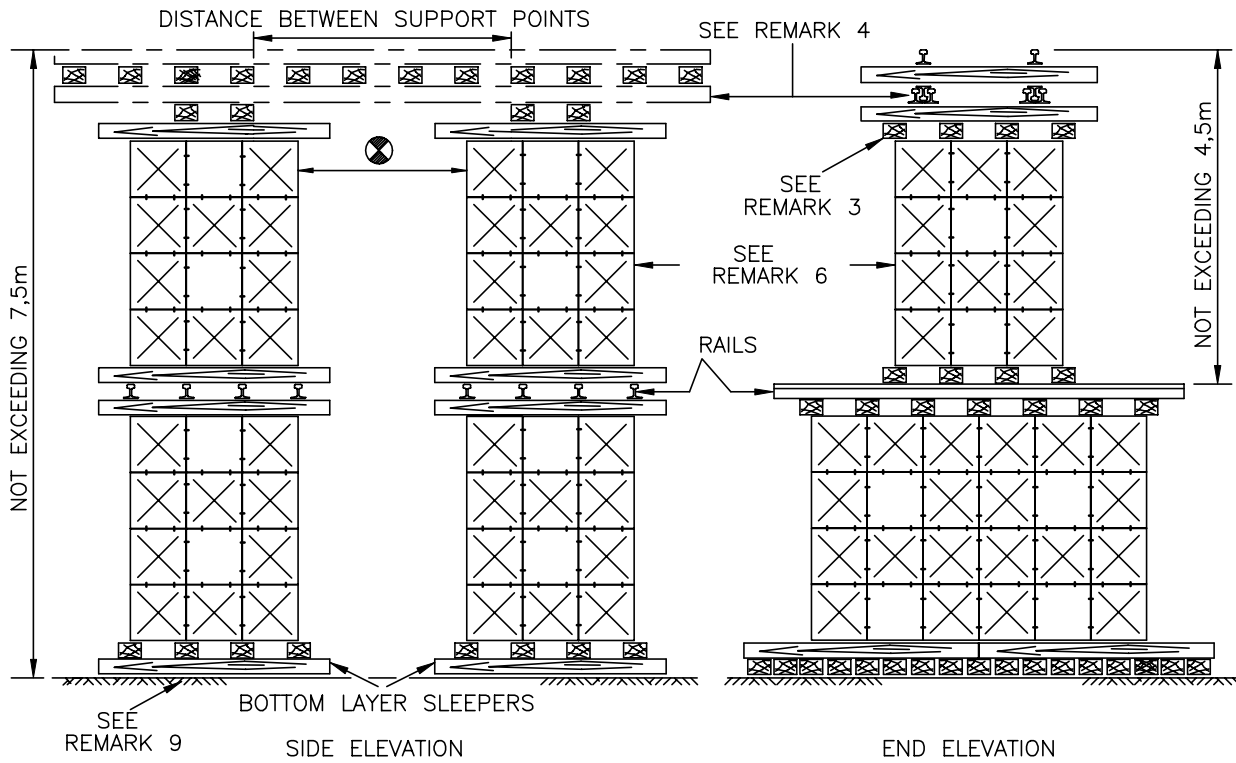

DOUBLE STEEL BRIDGING CRIB

REMARKS:

1. READ IN CONJUNCTION WITH CLAUSE 3.6.
2. IN ALL CASES THE BOTTOM LAYER OF SLEEPERS MUST BE PLACED PARALLEL TO THE TRACK AND CLOSE LAID.
3. SLEEPERS MUST BE PLACED AS SHOWN TO AVOID OVERSTRESSING THE CRIBS.
4. FOR BOTTOM RAIL GIRDER SEE ANEXURE 7 SHT 1.
5. \otimes DENOTES REQUIRED SPAN. (DISTANCE BETWEEN SUPPORT POINTS MINUS 1 200mm).
6. FOR STEEL CRIBS SEE DRAWING BE 6115 M.
7. SLEEPERS OR SUITABLE TIMBERS.
8. NOT TO BE USED ON LINES CARRYING HEAVY LOADS.
9. A QUALIFIED PROFESSIONAL ENGINEER MUST ENSURE THAT THE SUPERIMPOSED LOAD DOES NOT EXCEED THE BEARING PRESSURE OF THE GROUND.

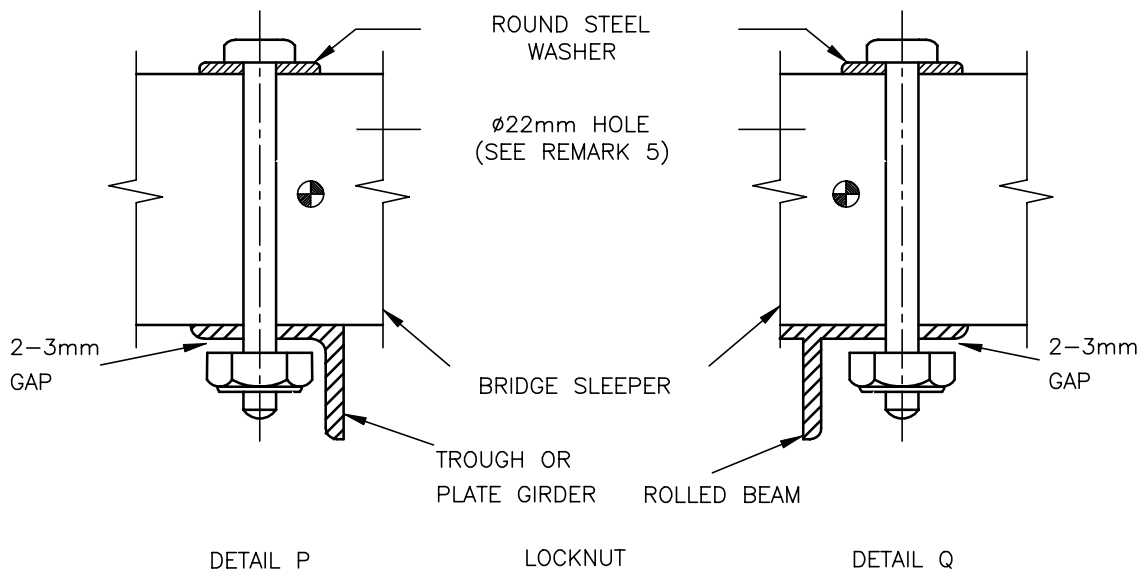
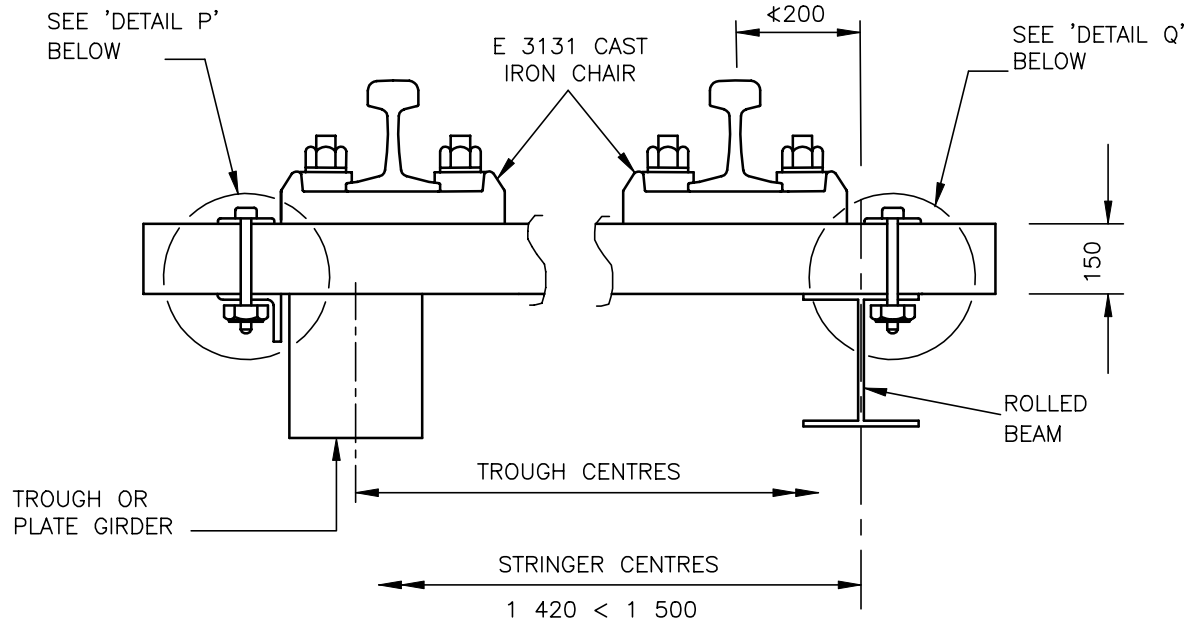

REMARKS:

1. SLEEPER BOLTS ARE INTENDED TO LOCATE THE SLEEPERS Laterally and Longitudinally BUT NOT VERTICALLY. FOR THIS REASON NUTS SHOULD BE TIGHTENED SO AS TO PROVIDE A 2mm TO 3mm GAP WHICH WILL PERMIT VERTICAL MOVEMENT CAUSED BY THE FLEXING OF THE RAIL UNDER LOAD.
2. SEE CLAUSE 3.5.7.
3.  BOLT & NUT, M20 SQUARE HEAD, 230mm LONG WITH LOCKNUT ("NYLOCK OR CLEVELOCK").
4. PLACE BOLT WITH NUT AT THE BOTTOM.
5. USE THE DRILLING JIG FOR SLEEPERS ON STEEL BRIDGES. SEE ANNEXURE 8 SHEET 3 FOR DETAIL.

FASTENING OF LAMINATED TIMBER
BRIDGE SLEEPERS

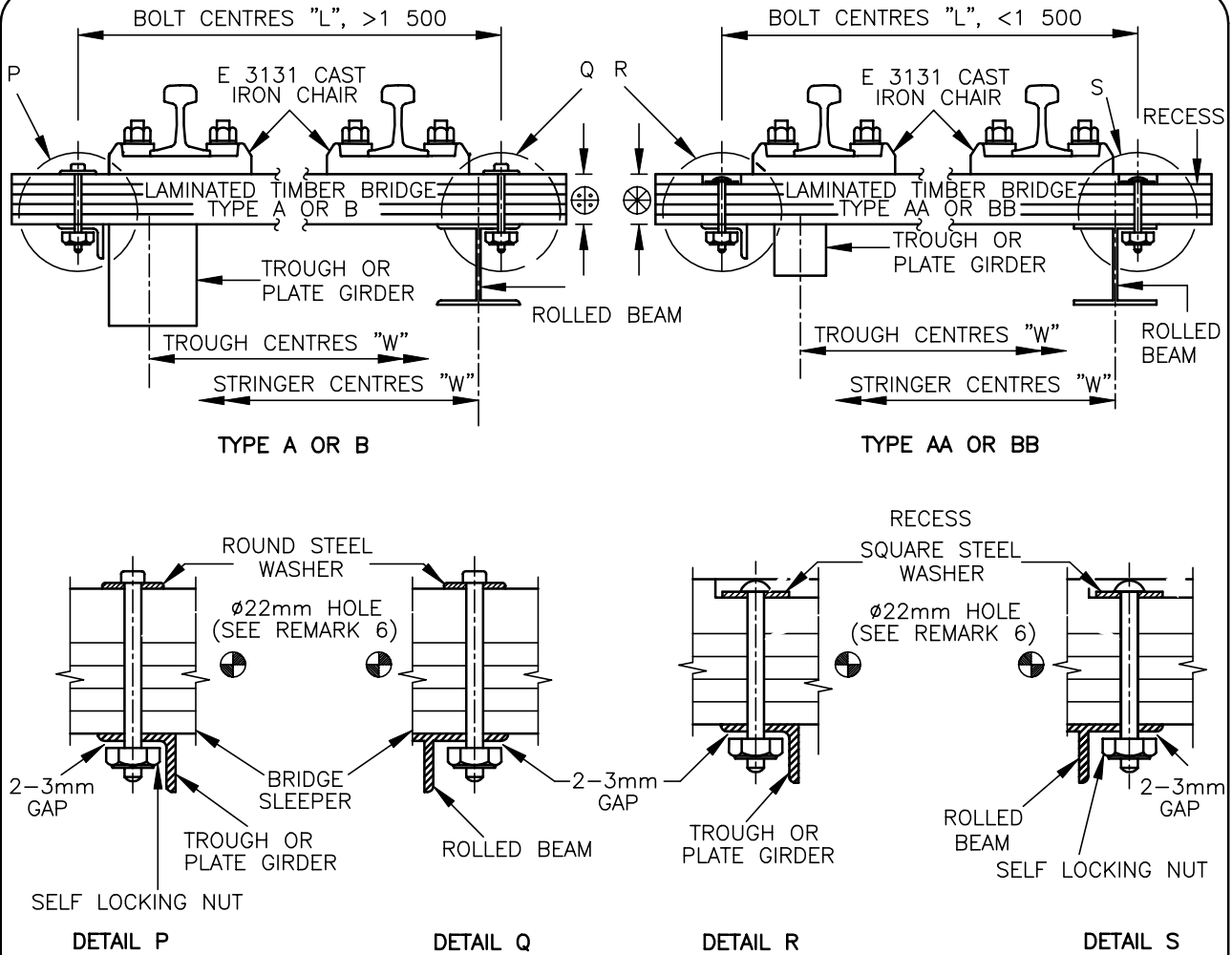

W	L	BRIDGE SLEEPER REQUIRED			STORES STOCK ITEM (SECTION 53)
		TYPE	SIZE	RECESS	
LESS THAN 1 200	MORE THAN 1 500	A	2 100x250x160	NO	911 691
	LESS THAN 1 500	AA		YES	911 706
MORE THAN 1 200	MORE THAN 1 500	B	2 100x250x190	NO	or 911 718 911 743
	LESS THAN 1 500	BB		YES	911 731

DESCRIPTION	SIZE mm	STORES STOCK ITEM (SECTION 53)
SQUARE STEEL WASHER	75 x 75 x 6	711 550
ROUND STEEL WASHER	OUTSIDE ϕ =52mm HOLE ϕ =26mm THICKNESS=5mm	711 776
SELF-LOCKING NUT	-	710 936
M20 SQUARE HEAD	230 LONG	214 831
M20 CARRIAGE BOLT	255 LONG	214 843
	200 LONG	212 249
	230 LONG	212 250

REMARKS:

- SLEEPER BOLTS ARE INTENDED TO LOCATE THE SLEEPERS Laterally and longitudinally but not vertically. For this reason nuts should be tightened so as to provide a 2mm to 3mm gap which will permit vertical movement caused by the flexing of the rail under load.
- BOLT & NUT, M20 SQUARE HEAD, 230mm LONG FOR TYPE A AND 255mm LONG FOR TYPE B LAMINATED SLEEPERS.
- M20 CARRIAGE BOLT, 200mm LONG FOR TYPE AA AND 230mm LONG FOR TYPE BB LAMINATED SLEEPERS.
- 160 (TYPE A) AND 190 (TYPE B).
- 160 (TYPE AA) AND 190 (TYPE BB).
- USE THE DRILLING JIG FOR SLEEPERS ON STEEL BRIDGES. SEE ANNEXURE 8 SHEET 3 FOR DETAIL.

FASTENING OF BRIDGE SLEEPERS : DRILLING
JIG FOR SLEEPERS ON STEEL BRIDGES

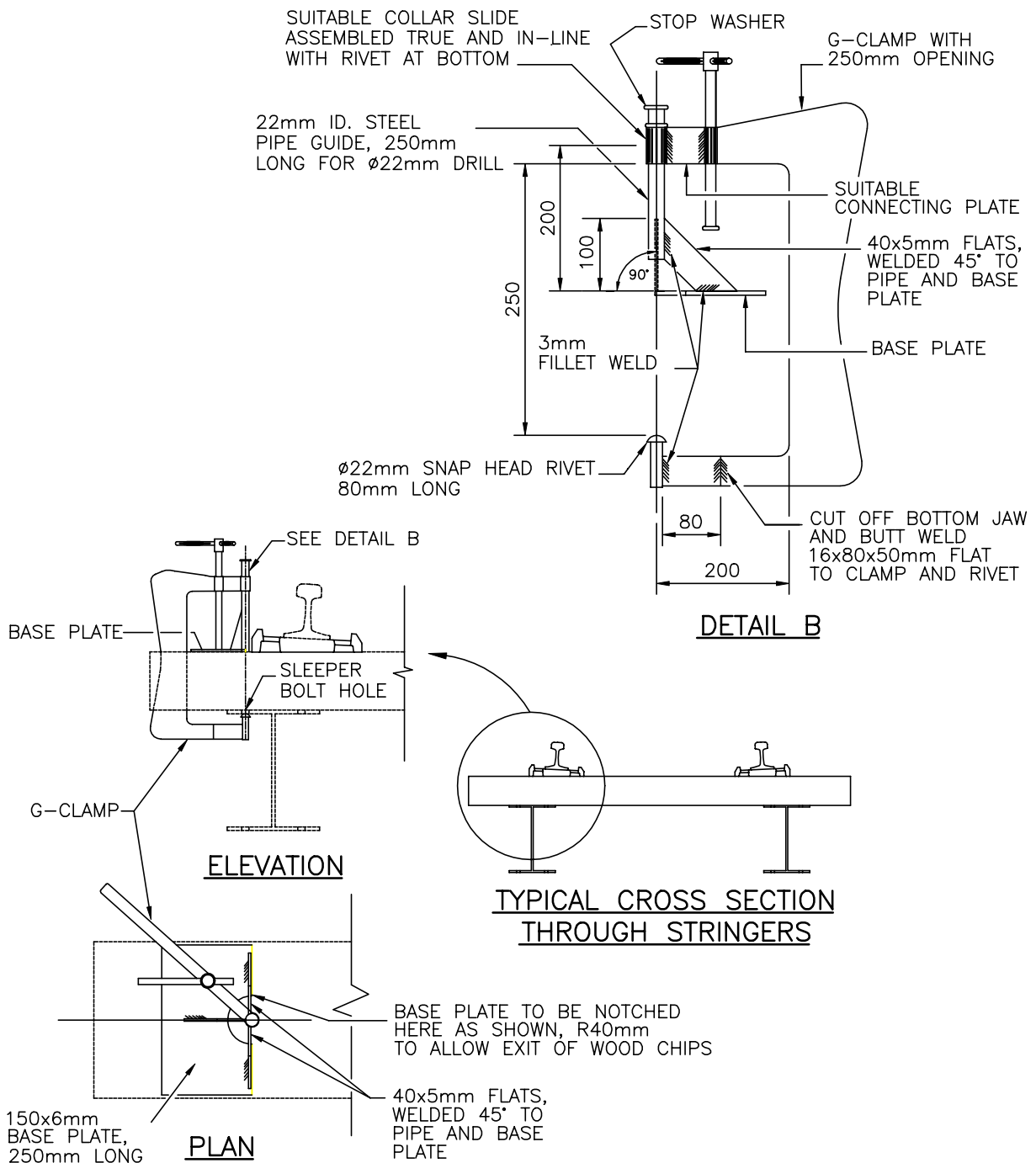

PROCEDURE:

1. REMOVE RAILS AND OLD SLEEPERS.
2. PLACE NEW SLEEPERS IN POSITION.
3. FASTEN E-3131 CHAIRS TO SLEEPERS IN CORRECT POSITIONS.
4. FASTEN RAILS TO CHAIRS.
5. ALIGN TRACK.
6. CLAMP JIG TO SLEEPER WITH THE SNAP HEAD RIVET LOCATING IN THE HOLE IN THE BOTTOM OF THE STRINGER.
7. DRILL HOLE WITH A SPECIAL $\phi 22$ mm X 500mm LONG DRILL BIT (SOMTA CODE 2592200) FROM THE TOP THROUGH THE COLLAR SLIDE.
8. REMOVE JIG AND FASTEN SLEEPER BOLT.

CURVE OFFSETS

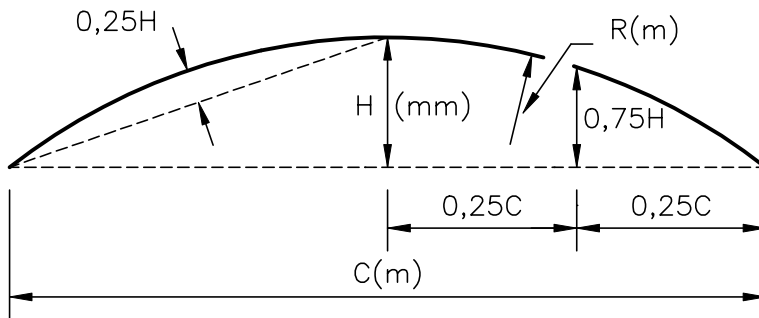

$$H = \frac{125C^2}{R}$$

REMARK: DIMENSION H TO NEAREST 5mm (USE FORMULA IF MORE ACCURACY IS REQUIRED.)

RADIUS (m)	MIDDLE OFFSETS H(mm)							
	CHORDS C(m)							
	6		10		20		12,192	
	H	0,75H	H	0,75H	H	0,75H	H	0,75H
50	90	70	250	190	1 000	750	370	280
55	80	60	230	170	910	680	340	255
60	75	55	210	155	835	625	310	230
70	65	50	180	135	715	535	265	200
80	55	40	155	115	625	470	230	175
90	50	40	140	105	555	415	205	155
100	45	35	125	95	500	375	185	140
110	40	30	115	85	455	340	170	125
120	40	30	105	80	415	315	155	115
130	35	25	95	70	385	290	145	105
140	30	25	90	65	355	270	135	100
150	30	25	85	65	335	250	125	95
175	25	20	70	55	285	215	105	80
200	25	15	65	45	250	190	95	70
225	20	15	55	40	220	165	85	60
250	20	15	50	40	200	150	75	55
275	15	10	45	35	180	135	70	50
300	15	10	40	30	165	125	60	45
350	15	10	35	25	145	105	55	40
400	10	10	30	25	125	95	45	35
450	10	10	30	20	110	85	40	30
500	10	5	25	20	100	75	40	30
600	10	5	20	15	85	65	30	25
700	5	5	20	15	70	55	30	20
800	5	5	15	10	65	45	25	15
900	5	5	15	10	55	40	20	15
1 000	5	5	15	10	50	40	20	15
1 200	5	5	10	10	40	30	15	10
1 500	5	0	10	5	35	25	10	10
2 000	0	0	5	5	25	20	10	5
3 000	0	0	5	5	15	15	5	5

CURVES : GAUGE ADJUSTMENT

WITHOUT TRANSITION CURVES

WITH TRANSITION CURVES

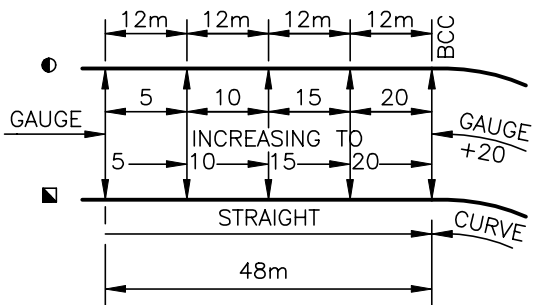

20mm

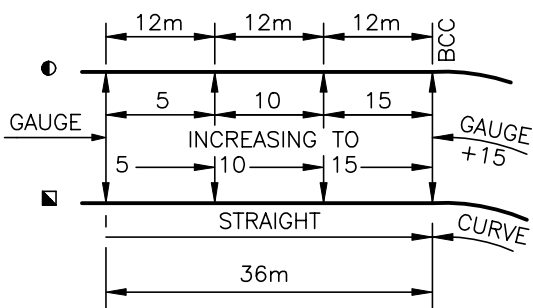
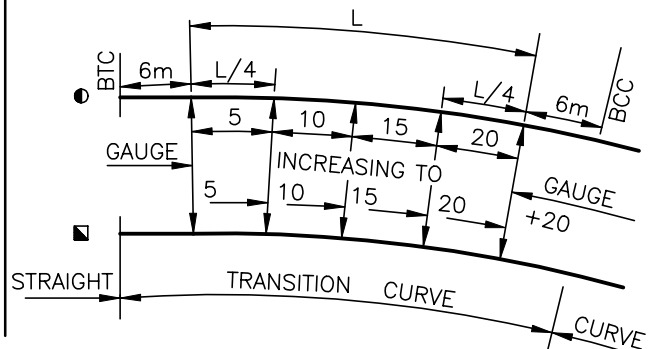

15mm

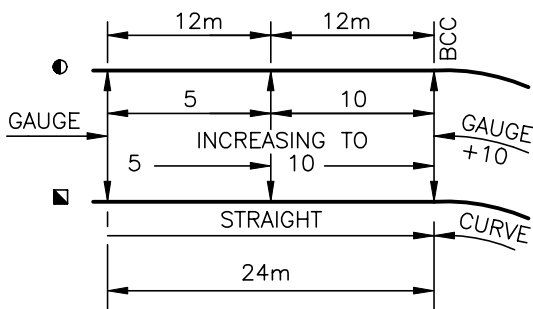
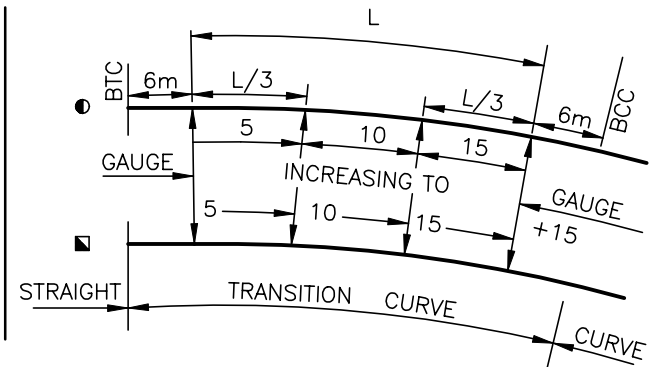

10mm

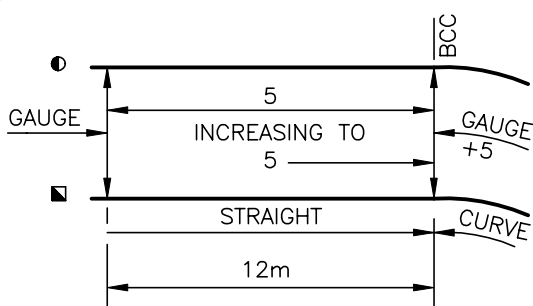
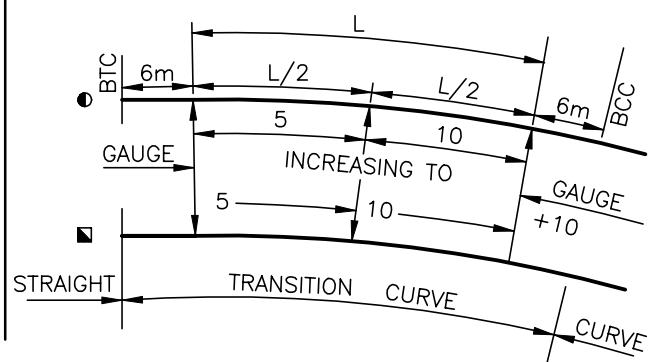

5mm

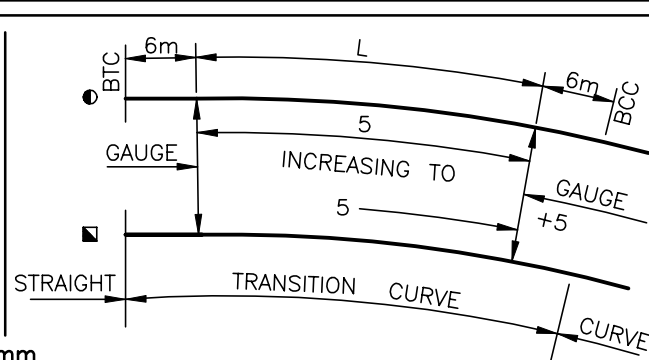

REMARKS:

1. FOR REMARKS SEE ANNEXURE 9 SHEET 3.

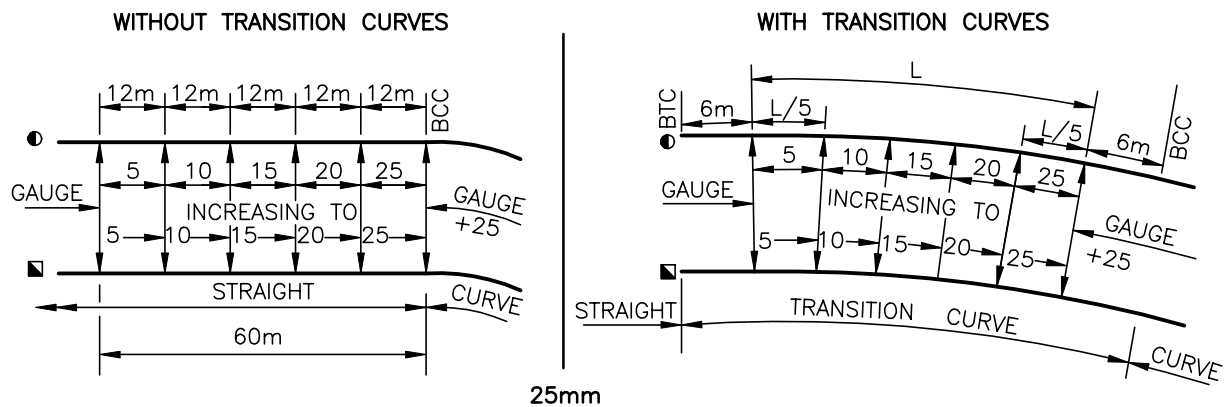

REMARKS:

1. ● GAUGE ADJUSTMENT FOR STEEL AND CONCRETE SLEEPERS. FOR LIMITATIONS SEE ANNEXURE 11 SHEETS 1 TO 3.
 2. ▣ GAUGE ADJUSTMENT FOR WOODEN SLEEPERS. FOR LIMITATIONS SEE ANNEXURE 11 SHEET 4.
- BTC INDICATES BEGINNING OF TRANSITION CURVE
BCC INDICATES BEGINNING OF CIRCULAR CURVE

MEASURING GAUGE ON SIDE-WORN RAILS

1. WHEN THE LOW LEG IS SIDEWORN, THE POINT TO MEASURE FROM IS THE SAME AS IN THE CASE OF THE HIGH LEG.
2. CHECK RAILS SHALL BE OF A CLASS NOT LOWER THAN CLASS B. IN YARDS CLASS C IS PERMITTED.

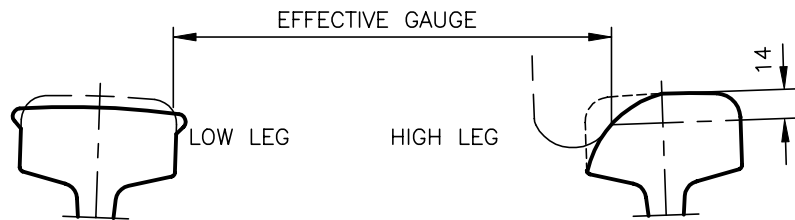

TEMPORARY TAPERED END PIECE

NO TRAIN SHALL BE PERMITTED THROUGH A CURVE WHILE ONLY A PORTION OF THE CHECK RAIL IS IN POSITION, UNLESS A TEMPORARY TAPERED END PIECE IS BOLTED TO THE LOOSE FISHPLATED END OF THE REMAINING CHECK RAIL.

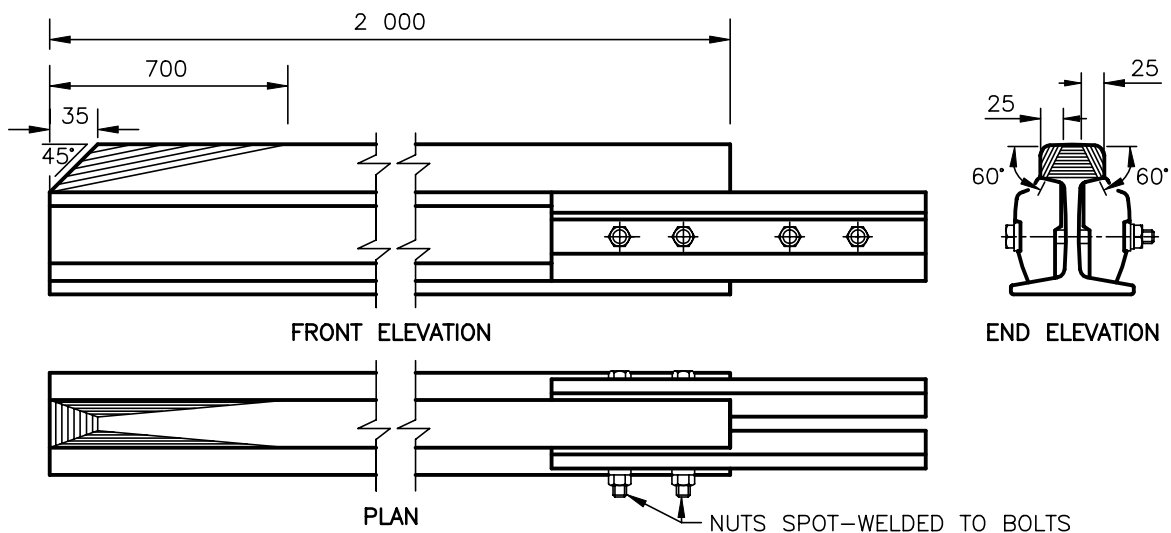

SUPERELEVATION AND MAXIMUM
PERMISSIBLE SPEED ON CURVES

TRACK GAUGE (mm)	1 065																610	
	160		100		90		80		60		50		40		30		40	
MAXIMUM SPEED (km/h)																		
RADIUS OF CURVE (m)	☉	■	☉	■	☉	■	☉	■	☉	■	☉	■	☉	■	☉	■	☉	■
50 - 90	-	-	-	-	-	-	-	-	-	-	-	-	-	-	-	-	15	20
60 - 89	-	-	-	-	-	-	-	-	-	-	-	-	-	-	-	-	15	20
90 - 99	40	100	35	100	35	100	35	100	35	90	30	70	30	60	30	30	20	20
100 - 109	40	100	35	100	35	100	35	100	35	90	30	70	30	60	30	30	20	20
110 - 119	50	90	35	90	35	90	35	90	35	90	30	60	30	60	30	30	20	20
120 - 139	50	90	40	90	40	90	40	90	40	80	30	60	30	60	30	30	20	20
140 - 159	50	90	40	90	40	90	40	80	40	80	40	60	40	60	30	30	20	20
160 - 179	50	80	40	80	40	80	40	80	40	70	40	60	40	50	30	30	25	15
180 - 199	60	80	50	80	50	80	40	70	40	70	40	50	40	50	30	30	25	15
200 - 219	60	80	50	80	50	80	50	70	50	70	40	50	40	40	30	30	30	15
220 - 239	60	80	50	80	50	80	50	70	50	70	50	50	40	40	30	30	30	15
240 - 269	70	70	50	70	50	70	50	70	50	60	50	50	40	30	30	30	30	15
270 - 299	70	70	60	70	60	70	50	60	50	60	50	40	40	30	30	20	35	15
300 - 349	70	70	60	70	60	70	60	60	60	60	50	40	40	30	30	20	35	15
350 - 399	80	60	60	60	60	60	60	60	60	50	50	30	40	20	30	20	40	15
400 - 449	80	60	70	60	70	60	70	60	60	40	50	20	40	20	30	10	40	10
450 - 499	90	60	70	60	70	60	70	50	60	40	50	20	40	20	30	10	40	10
500 - 549	90	60	80	60	80	60	70	50	60	30	50	10	40	20	30	10	40	5
550 - 599	100	50	80	50	80	50	80	50	60	30	50	10	40	20	30	10	40	5
600 - 699	100	50	80	50	80	50	80	50	60	30	50	10	40	10	30	10	40	0
700 - 799	100	50	90	50	90	50	80	40	60	20	50	10	40	10	30	10	40	0
800 - 849	110	40	90	40	90	40	80	40	60	20	50	10	40	10	30	10	40	0
850 - 899	120	40	100	40	90	40	80	40	60	20	50	10	40	10	30	0	40	0
900 - 999	120	40	100	40	90	40	80	30	60	20	50	10	40	10	30	0	40	0
1000 - 1199	130	40	100	40	90	40	80	30	60	20	50	10	40	10	30	0	40	0
1200 - 1499	140	30	100	30	90	30	80	20	60	10	50	10	40	10	30	0	40	0
1500 - 1699	150	20	100	20	90	20	80	20	60	10	50	0	40	0	30	0	40	0
1700 - 1999	160	20	100	20	90	20	80	20	60	10	50	0	40	0	30	0	40	0
2000 - 2999	160	10	100	10	90	10	80	10	60	10	50	0	40	0	30	0	40	0
3000 - - -	160	0	100	0	90	0	80	0	60	0	50	0	40	0	30	0	40	0

REMARKS:

- NEW LINES MUST NOT BE BUILT FOR MAXIMUM SPEEDS OF 90 AND 50km/h. THIS INFORMATION IS INCLUDED FOR EXISTING LINES WHERE THESE MAXIMUM SPEEDS ARE AT PRESENT IN OPERATION.
- CANT FOR EACH CURVE IN TUNNELS WILL BE DETERMINED SEPARATELY BY THE ENGINEER IN CHARGE OF TRACK MAINTENANCE.
- FOR 160km/h SECTIONS, 2 SPEED BOARDS MUST BE ERECTED. THE NORMAL YELLOW BOARD AND A BLUE BOARD WITH WHITE FIGURES DIRECTLY BELOW THE YELLOW BOARD.
- ☉ DENOTES SPEED IN km/h.
- DENOTES CANT IN mm.
- READ TOGETHER WITH SUB-CLAUSE 9.3.4.
- FOR A SPEED OF 15 km/h (1 065mm GAUGE) HALF THE CANT OF 30 km/h MUST BE USED.

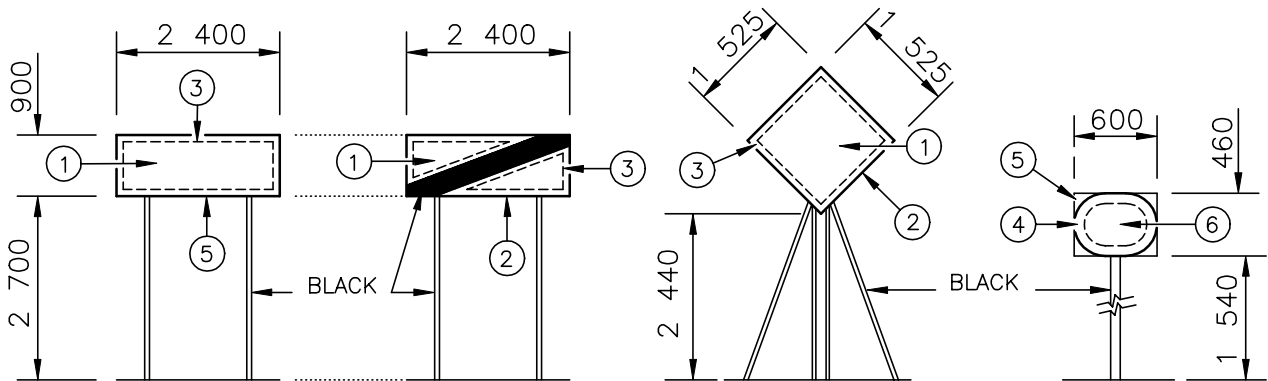

WARNING BOARD

DISTANCE BOARD
FOR C.T.C.

WATERING BOARD

WHISTLE BOARD

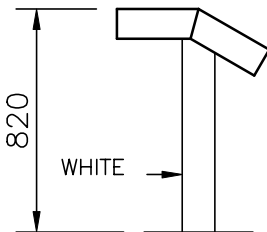

GRADE POST

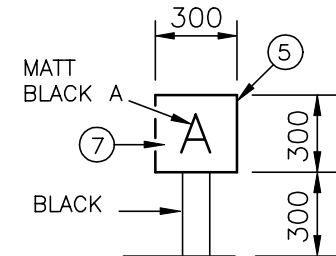

APPARATUS
INDICATION BOARD
(MAY ALSO BE ROUND IN SHAPE)

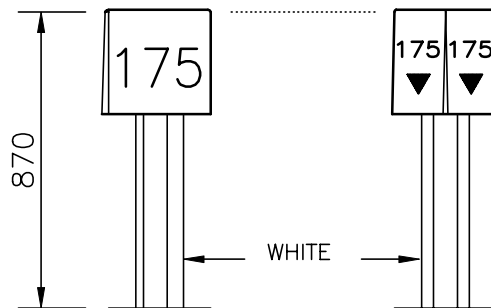

KILOMETRE POSTS

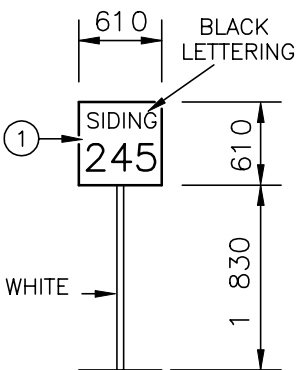

PRIVATE
SIDING BOARD

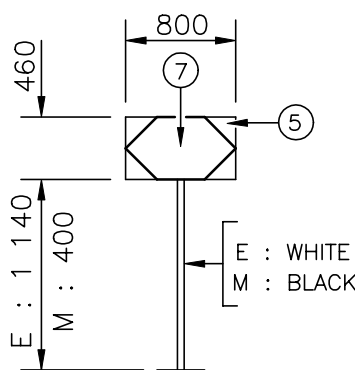

SPEED
DE-RESTRICTION
BOARD

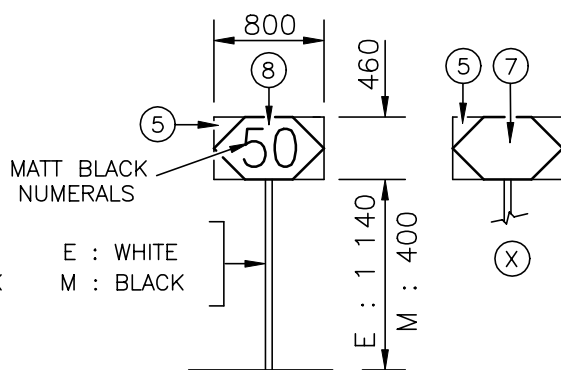

SPEED RESTRICTION AND
DE-RESTRICTION BOARD

REMARKS:

1. (1) WHITE.
2. (2) REVERSE SIDE - BLACK.
3. (3) REFLECTIVE WHITE BORDER OF 100mm.
4. (4) REFLECTIVE WHITE BORDER OF 75mm.
5. (5) DOVE GREY CHROMADEK REVERSE SIDE.
6. (6) PIGMENTED WHITE.
7. (7) REFLECTIVE WHITE.
8. (8) REFLECTIVE YELLOW.
9. (X) DE-RESTRICTION ON REVERSE SIDE.
10. E : SINGLE LINES.
11. M : MULTIPLE LINES.
12. FOR FURTHER DETAILS SEE DRAWING D-184 SHEETS 2 AND 4 AND D-176 SHEETS 2, 3 AND 5.

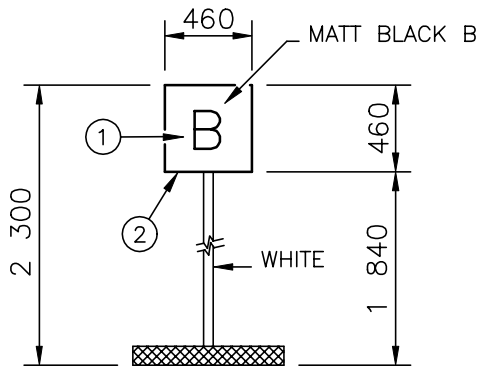

TAMPING MACHINE WARNING BOARD

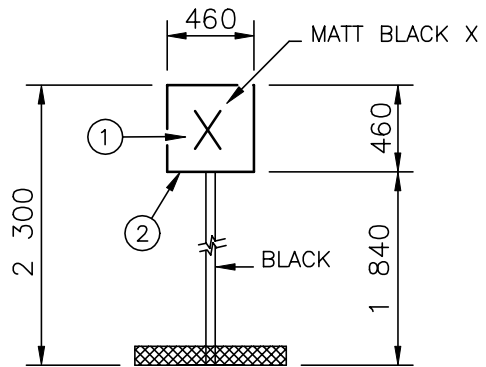

TAMPING MACHINE X BOARD
(SEE REMARK 5)

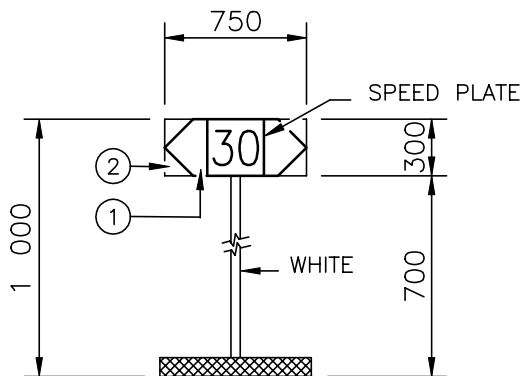

SPEED REDUCTION BOARD
(SEE REMARKS 6 & 8)

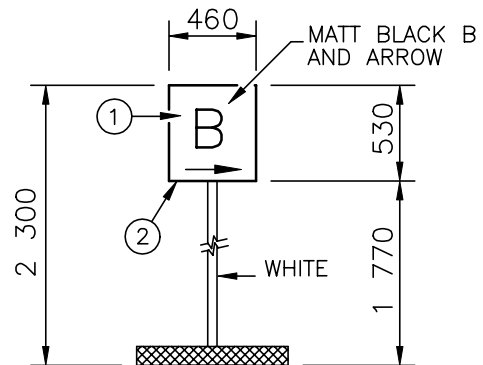

TAMPING MACHINE INDICATION BOARD
(SEE REMARK 7)

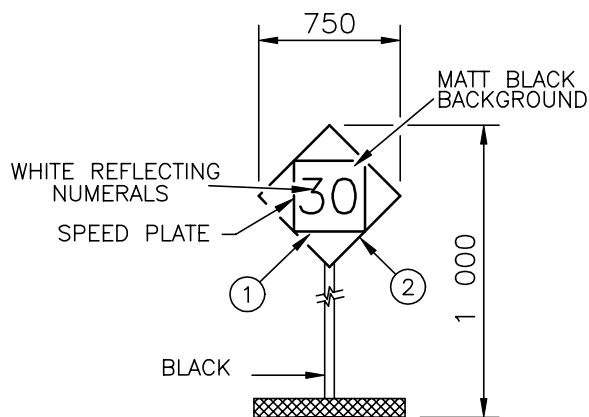

BEGINNING OF DANGER ZONE
(SEE REMARKS 6 & 8)

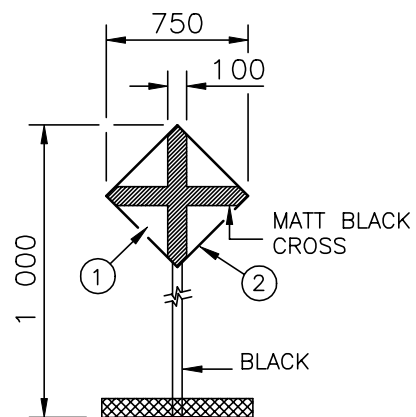

END OF DANGER ZONE
(SEE REMARK 6)

REMARKS:

1. (1) REFLECTIVE YELLOW.
2. (2) DOVE GREY CHROMADEK REVERSE SIDE.
3. FOR SIGN BOARD POSITIONING SEE ANNEXURE 10 SHEET 3.
4. FOR FURTHER DETAILS SEE DRAWING D-184 SHEET 1.
5. AT OFFTRACK PLATFORM.
6. THE TOP OF THESE BOARDS MUST NEVER BE MORE THAN 865mm ABOVE RAIL LEVEL.
7. TO BE PLACED AT ROADSIDE TO INDICATE ACCESS TO WORKING SITE.
8. THE SPEED PLATE MUST INDICATE THE SAME SPEED ON BOTH SIDES.

TRACK SIGN BOARDS : LAYOUT

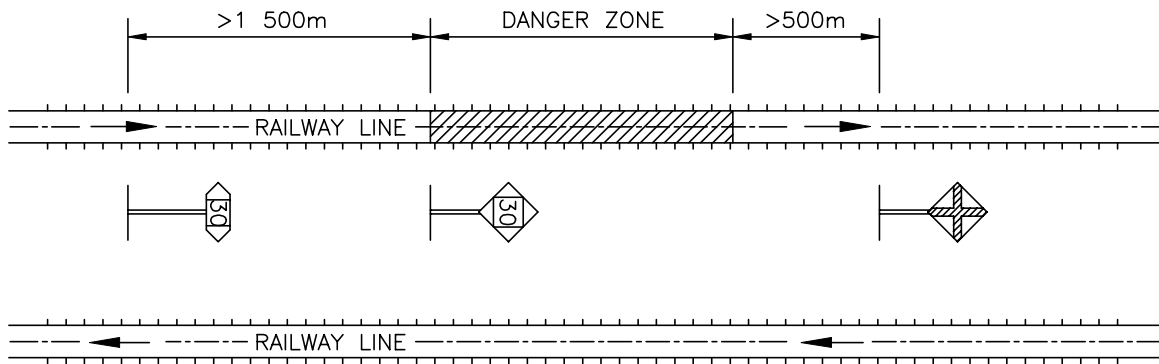

MULTIPLE UNI-DIRECTIONAL LINES

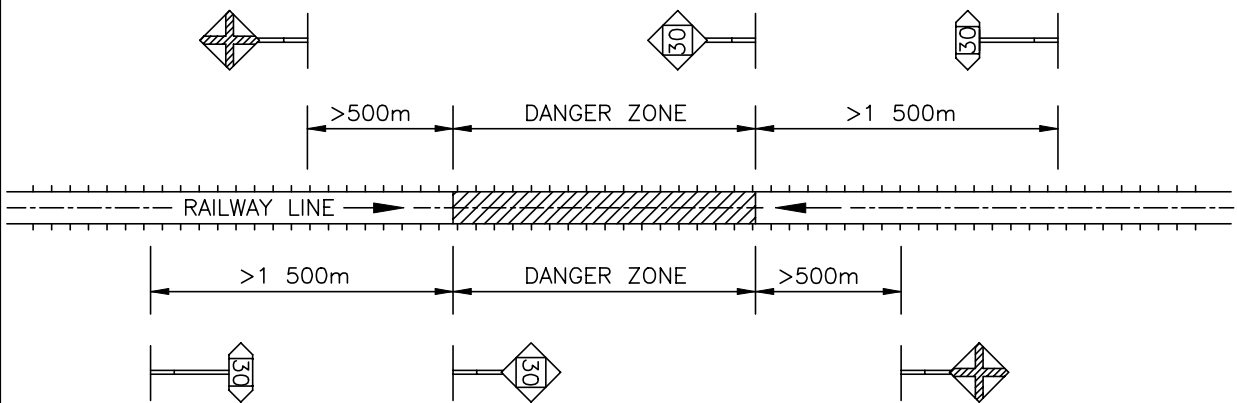

SINGLE OR BI-DIRECTIONAL LINES

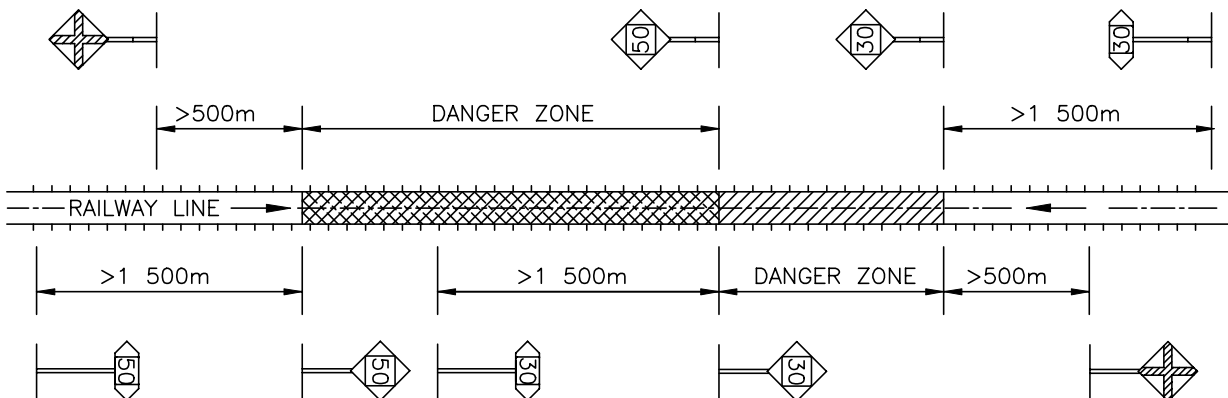

TANDEM SPEED REDUCTION ON A SINGLE LINE WITH BI-DIRECTIONAL TRAFFIC

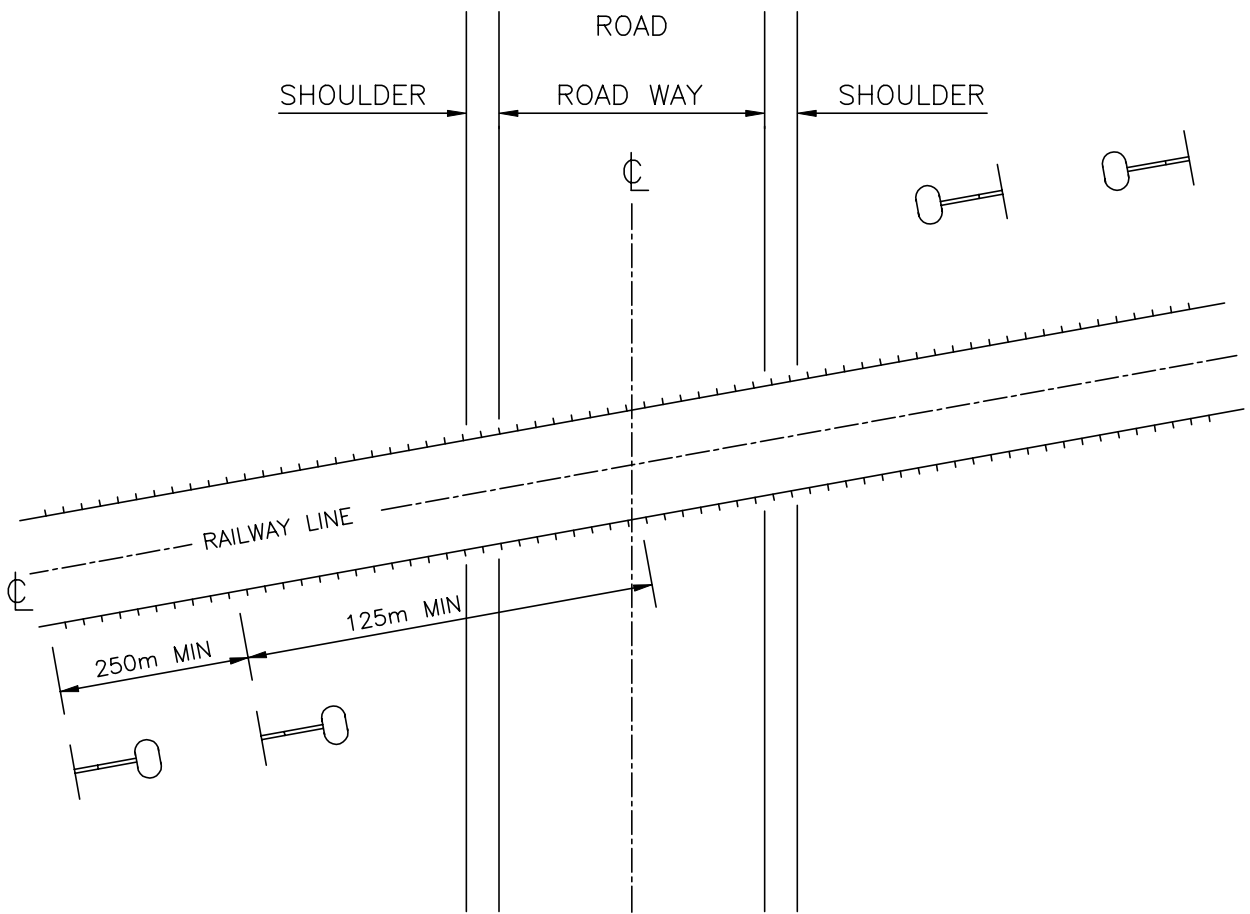

REMARKS:

1. FOR POSITIONING OF SIGNS SEE CHAPTER 9.

SLEEPER FASTENINGS : FIST BTR.

SLEEPER	RAIL	SPRING CLIP	PIN	GAUGE PLATE COMBINATIONS				
				OUTER	INNER	GAUGE (mm)	INNER	OUTER
FY	UIC-60	FY BROWN	FY BLUE	G	G	1 063	G	G
	S-60	FY BLUE		H2	H1	1 067	G	G
				H2	H1	1 072	H1	H2
	57kg		F	F	1 068	F	F	
F4/F1	48kg	F4 RED	F4 BLACK	L1	L2	1 065	L2	L1
				L1	L2	1 071	L1	L2
				L2	L1	1 077	L1	L2
	57kg			E	E	1 065	E	E
				E	E	1 070	D1	D2
				D2	D1	1 075	D1	D2
	48kg			B1	B2	1 065	B2	B1
				B1	B2	1 070	B1	B2
				B2	B1	1 075	B1	B2
	40kg			K1	K2	1 065	K2	K1
				B1	B2	1 070	B2	B1
				B1	B2	1 075	B1	B2
57kg	B2	B1	1 080	B1	B2			
	D2	D1	1 067	D1	D2			
F3	57kg			B2	B1	1 067	B1	B2
	48kg			DD2	DD1	1 067	DD1	DD2
F2	57kg	F2 BLACK		BB2	BB1	1 067	BB1	BB2
	48kg							

SLEEPER FASTENINGS : PANDROL

SLEEPER	RAIL	GAUGE PLATE COMBINATIONS				
		OUTER	INNER	GAUGE (mm)	INNER	OUTER
PY	UIC-60	UIC-6-9	UIC-6-9	1 062	UIC-0-4	UIC-11-13
		UIC-6-9	UIC-6-9	1 066	UIC-6-9	UIC-6-9
		UIC-0-4	UIC-11-13	1 071	UIC-6-9	UIC-6-9
		UIC-0-4	UIC-11-13	1 076	UIC-11-13	UIC-0-4
	S-60	T6	T6	1 062	T0	T11
T6		T6	1 066	T6	T6	
T0		T11	1 071	T6	T6	
T0		T11	1 076	T11	T0	
57kg	T17	T6	1 062	T11	T14	
	T14	T11	1 065	T11	T14	
	T11	T14	1 067	T11	T14	
	T11	T14	1 069	T14	T11	
	T6	T17	1 073	T14	T11	
	T6	T17	1 077	T17	T6	
	T0	T23	1 082	T17	T6	
	T0	T23	1 087	T23	T0	
48kg	T23	T17	1 067	T17	T23	
	T23	T17	1 072	T23	T17	
	T17	T23	1 077	T23	T17	
P2	57kg	T11	T0	1 060	T6	T6
		T6	T6	1 064	T6	T6
		T0	T11	1 069	T6	T6
		T0	T11	1 074	T11	T0
	48kg	T17	T11	1 064	T11	T17
		T17	T11	1 069	T17	T11
		T11	T17	1 074	T17	T11
		T11	T17	1 078	T23	T6
		T6	T23	1 082	T23	T6
	40kg	T23	T6	1 060	T6	T23
		T17	T11	1 065	T6	T23
		T17	T11	1 070	T11	T17
T17		T11	1 075	T17	T11	
T11		T17	1 080	T17	T11	
T11		T17	1 084	T23	T6	
P1	57kg	T6	T0	1 062	T6	T0
		T0	T6	1 067	T6	T0
	48kg	T17	T6	1 062	T11	T11
		T11	T11	1 067	T11	T11
		T6	T17	1 071	T11	T11
		T6	T17	1 075	T17	T6
		T0	T23	1 080	T17	T6
	40kg	T17	T6	1 063	T6	T17
		T17	T6	1 068	T11	T11
		T11	T11	1 073	T11	T11
		T6	T17	1 077	T11	T11
		T6	T17	1 081	T17	T6

SLEEPER	RAIL	CLIP COMBINATIONS : E-3085				
		OUTER	INNER	GAUGE (mm)	INNER	OUTER
E-3277	48kg	B	B	1 060	E	D
		B	B	1 065	A	C
		A	C	1 070	A	C
		A	C	1 075	B	B
		E	D	1 080	B	B
		E	D	1 085	C	A
	40kg	C	A	1 061	E	D
		C	A	1 066	A	C
		B	B	1 071	A	C
		B	B	1 076	B	B
		A	C	1 081	B	B
		A	C	1 086	C	A
	30kg	F2	B	1 065	B	F2
		F	C	1 070	B	F2
		F	C	1 075	C	F
		D	C	1 078	C	F
		C	F	1 083	C	F
		B	F2	1 088	C	F

SLEEPER	RAIL	GAUGE PLATE COMBINATIONS : E-3131				
		OUTER	INNER	GAUGE (mm)	INNER	OUTER
WOOD WITH E-3131 CAST IRON CHAIRS	57kg	L	J	1 061	K	J
		K	N	1 066	L	J
		N	K	1 071	N	K
		N	K	1 074	K	N
		J	L	1 079	K	N
		J	L	1 084	L	J
	48kg	L	L	1 060	K	M
		K	M	1 065	K	M
		K	M	1 070	L	L
		K	M	1 075	M	K
		K	M	1 080	L	L
		K	M	1 085	M	K
	40kg	L	L	1 060	K	M
		K	M	1 065	K	M
		K	M	1 070	L	L
		K	M	1 075	M	K
		K	M	1 080	L	L
		K	M	1 085	M	K

METHOD OF STACKING WOOD SLEEPERS

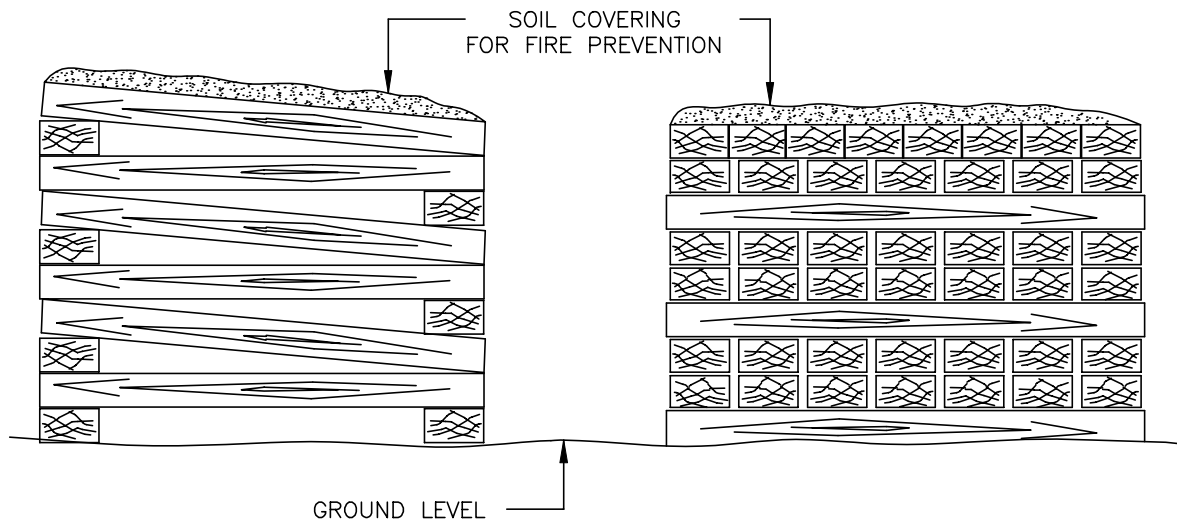

REMARKS:

1. SEE CLAUSE 10.1.5

METHOD OF UNLOADING
CONCRETE SLEEPERS

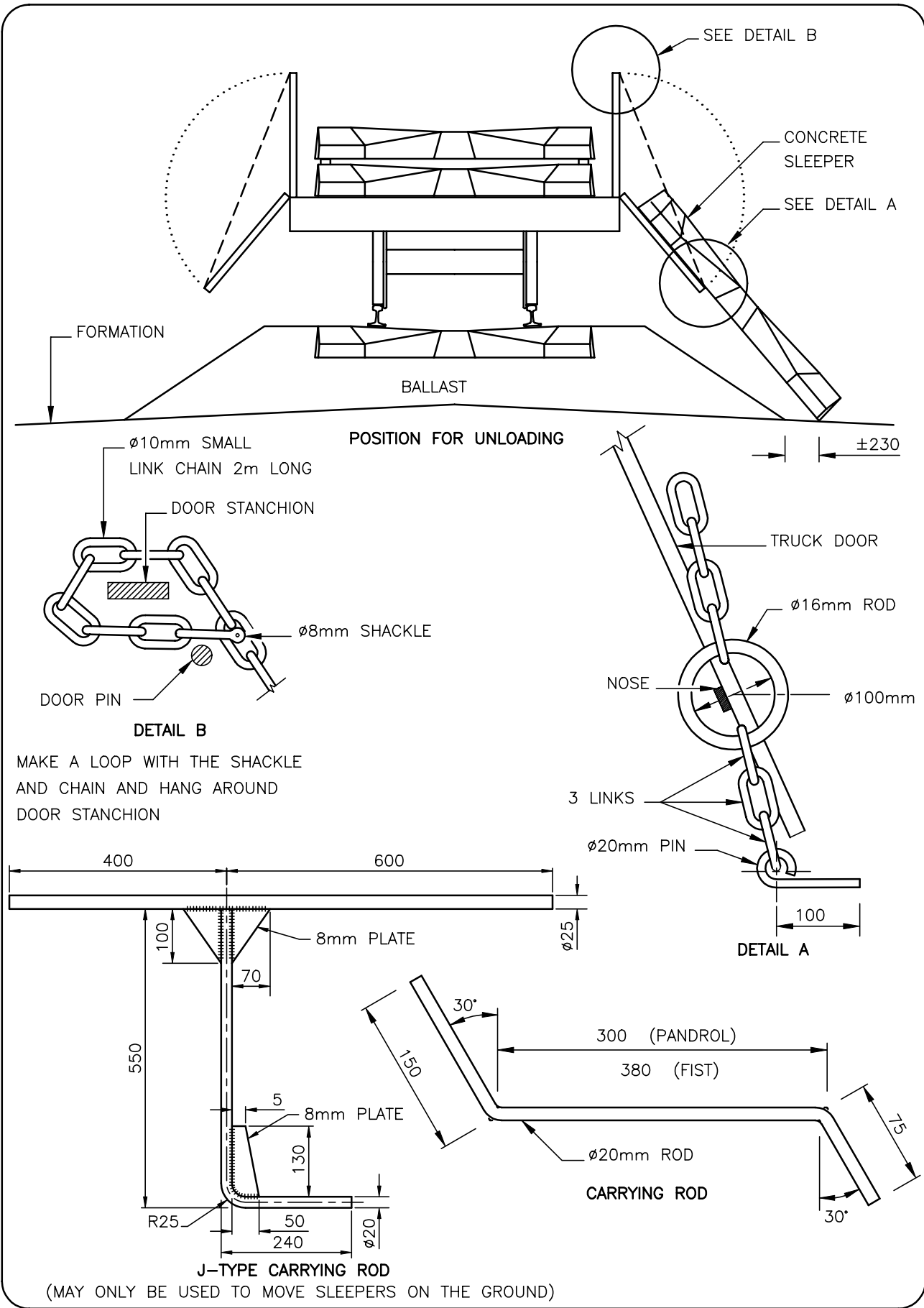

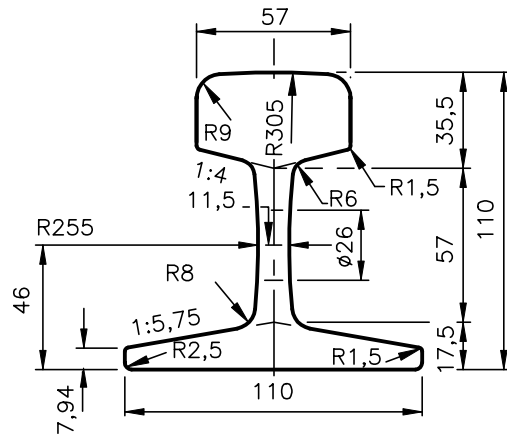

30kg/m

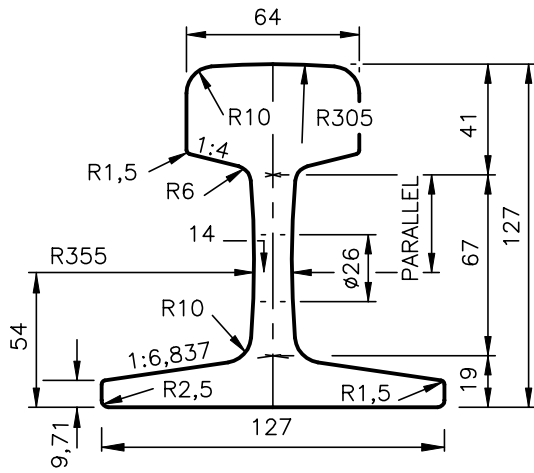

40kg/m

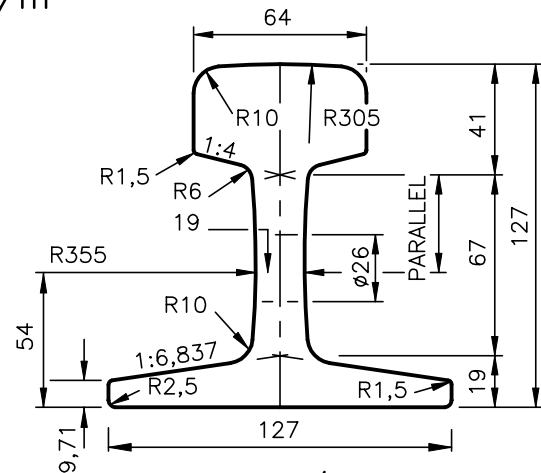

43kg/m
(HARBOUR AREAS)

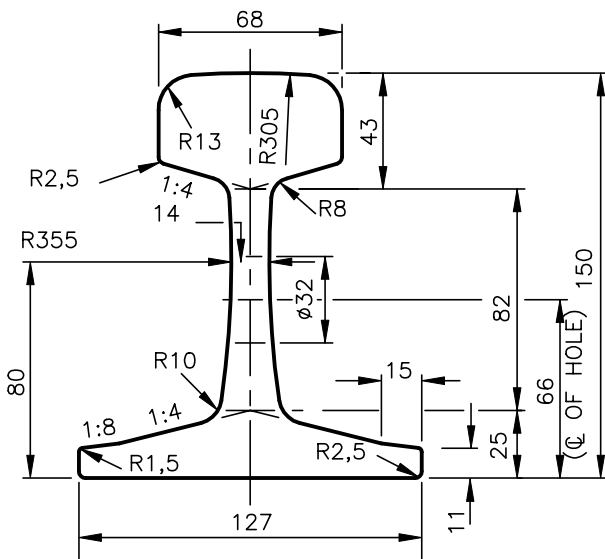

48kg/m

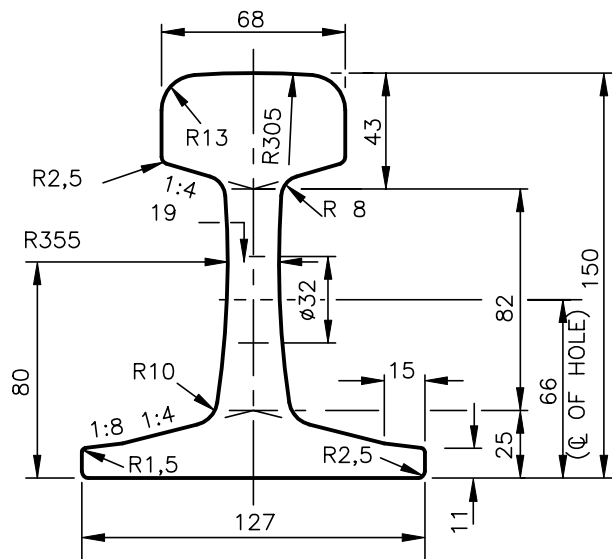

51kg/m
(FLEXIBLE POINTS BLADE
AND UNDERCUT STOCK RAIL)

REMARKS:

1. FOR PROPERTIES SEE ANNEXURE 14 SHT 4.

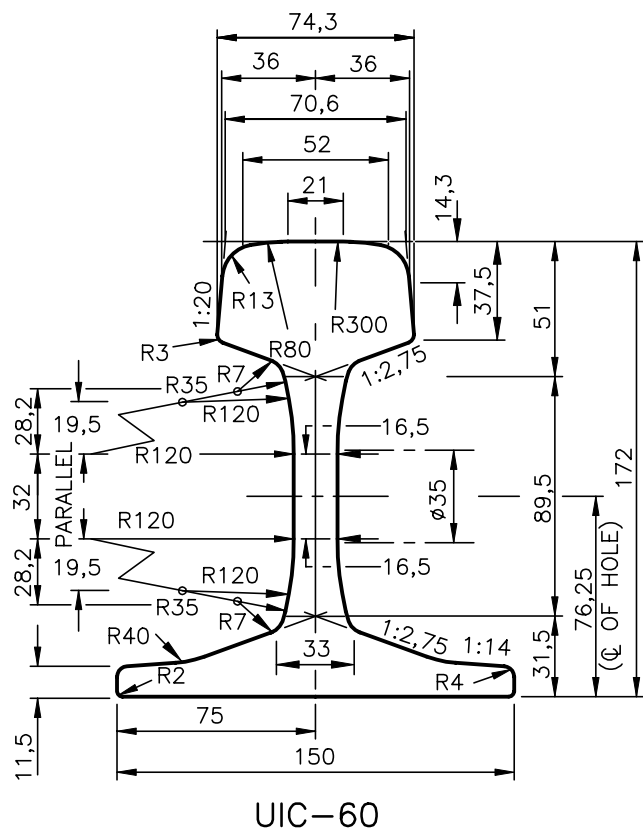
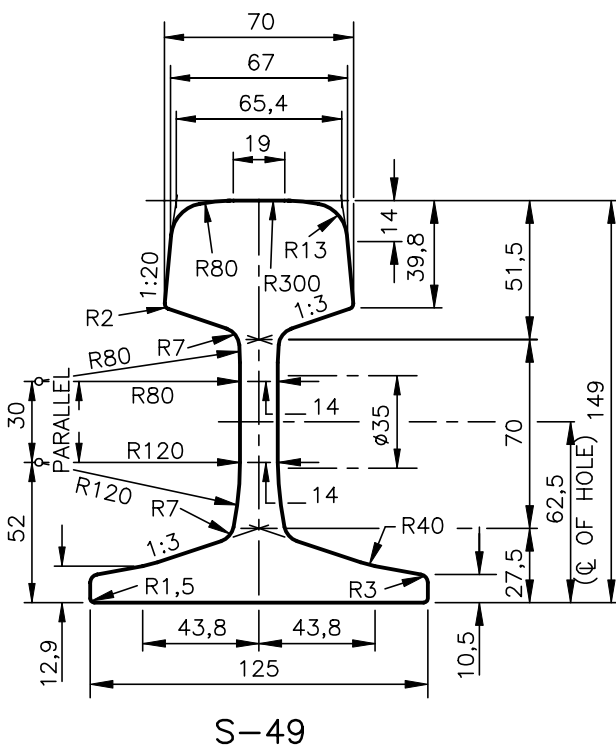
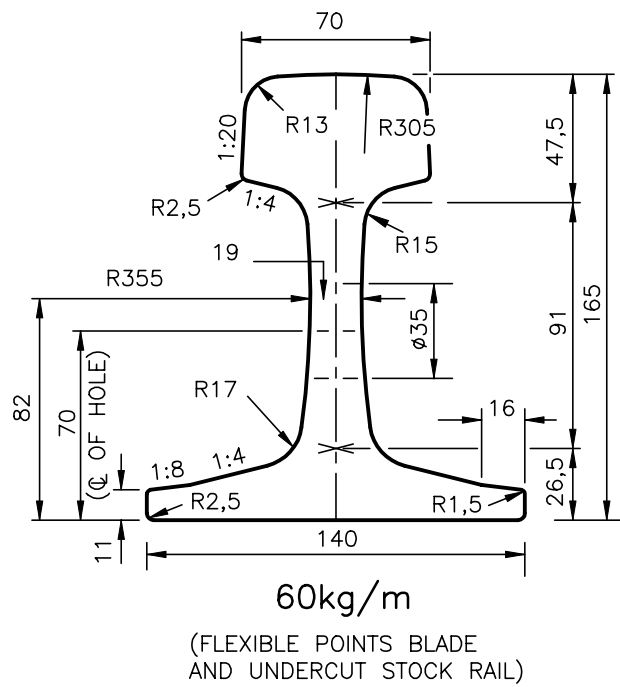
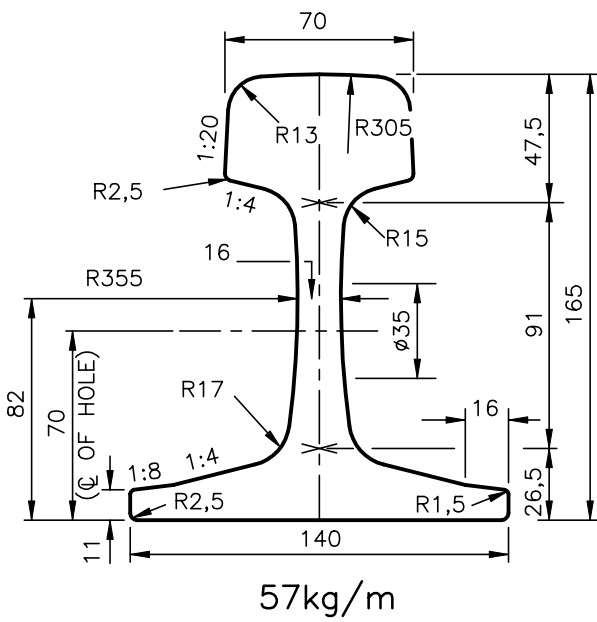

REMARKS:

- FOR PROPERTIES SEE ANNEXURE 14 SHT 4.

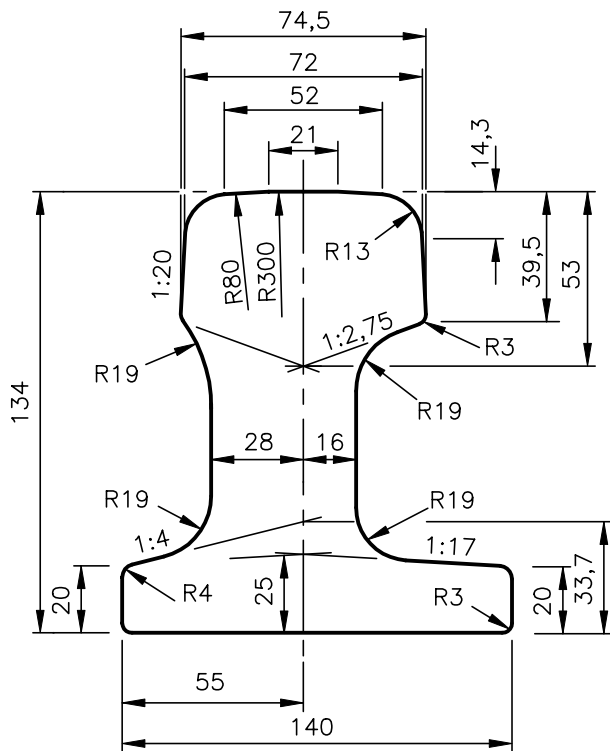

Zu-1-60

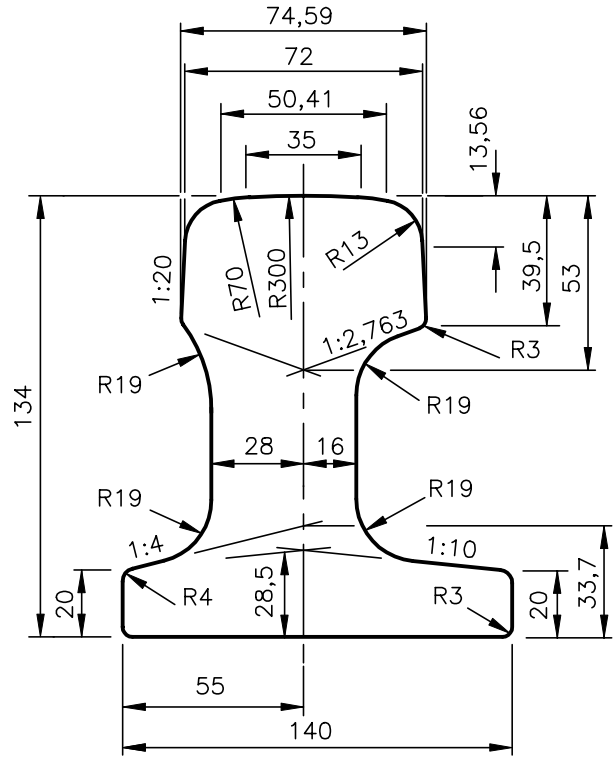

Z-S60-SAR

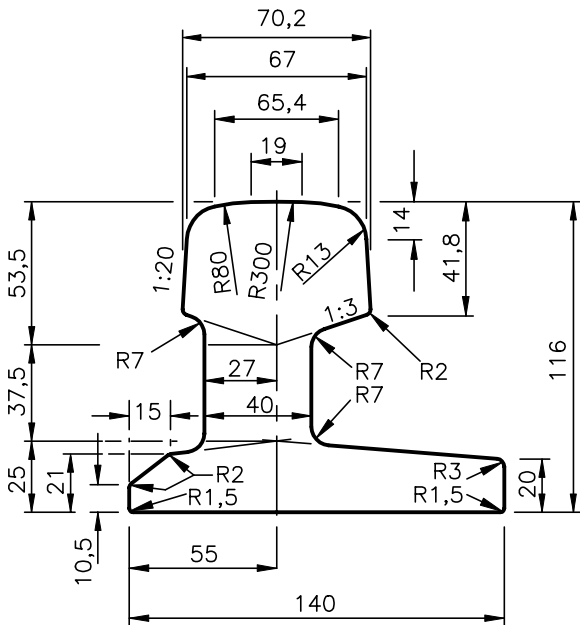

Zu-2-49

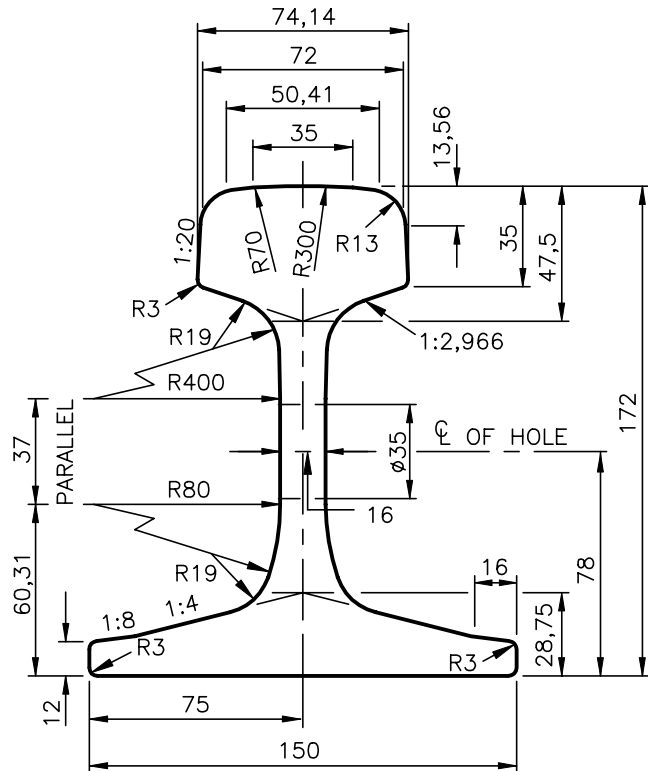

S-60-SAR

REMARKS:

1. FOR PROPERTIES SEE ANNEXURE 14 SHT 4.

RAIL PROPERTIES

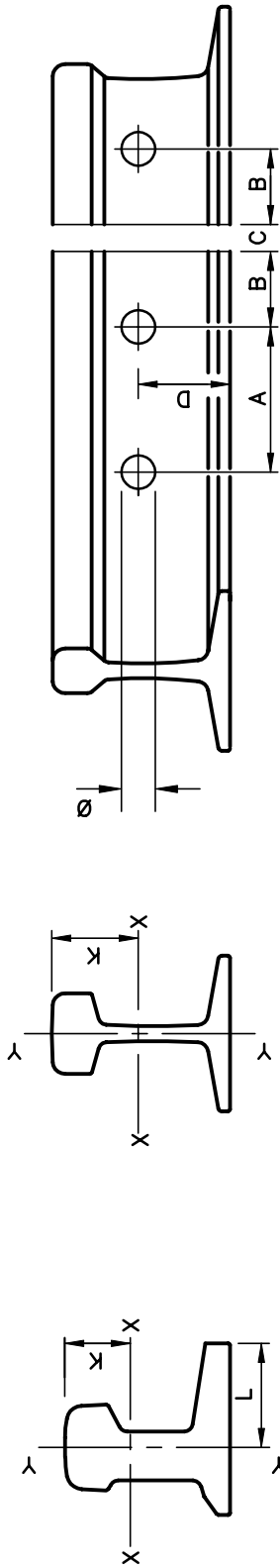

RAIL	MASS (kg/m)	HOLING						AREAS				PROPERTIES				DRAWING		
		A	B	C	D	Ø	NUMBER	HEAD (%)	WEB (%)	FLANGE (%)	SECTION (cm ²)	I (cm ⁴)	Z (cm ³)	K (mm)	L (mm)			
		X - X	Y - Y															
30kg	30	100	47	6	46	26	4	45,11	18,87	36,02	38,537	626,89	158,18	110,94	56,36	-	E-192M	
40kg	40	100	47	6	54	26	4	44,86	19,44	35,70	51,715	1 115,38	281,56	169,20	65,92	-	E-346	
43kg	43	100	47	6	54	26	4	42,42	24,03	33,55	55,230	1 129,00	280,30	170,10	66,35	-	E-3215M	
48kg	48	100	67	6	66	32	4	41,55	22,65	35,80	60,180	1 822,00	316,04	234,18	78,50	-	E-358M	
51kg	51	100	67	6	66	32	4	39,00	27,80	33,20	64,850	1 844,00	320,50	234,60	78,60	-	E-358M	
57kg	57	100	67	6	70	35	4	41,55	23,02	35,43	73,240	2 650,80	442,00	336,46	86,21	-	E-3232M	
60kg	60	100	67	6	70	35	4	40,14	25,69	34,17	76,125	2 703,27	445,39	343,97	86,41	-	E-3232M	
S-60-SAR	60,34	100	67	6	78	35	4	37,53	24,02	38,45	77,020	3 097,82	550,40	395,63	FLANGE	93,70	-	E-3326
Z-S60-SAR	72,83	-	-	-	-	-	-	34,88	30,63	34,47	92,980	1 734,40	746,94	292,98	FLANGE	74,80	82,70	-
UIC-60	60,34	100	67	6	76,25	35	4	40,22	22,55	37,23	76,860	3 055,00	512,90	335,50 377,40	HEAD FLANGE	91,05	-	700-E-736
Zu-1-60	73,00	-	-	-	-	-	-	-	-	-	93,000	1 728,00	743,50	229,90 293,80	HEAD FLANGE	75,15	82,24	-
S-49	49,43	100	67	6	62,5	35	4	47,45	17,56	34,99	62,970	1 189,00	320,00	240,00	FLANGE	75,70	-	700-E-722
Zu-2-49	62,20	-	-	-	-	-	-	-	-	-	79,260	1 075,00	700,00	162,00	HEAD	66,30	81,00	-

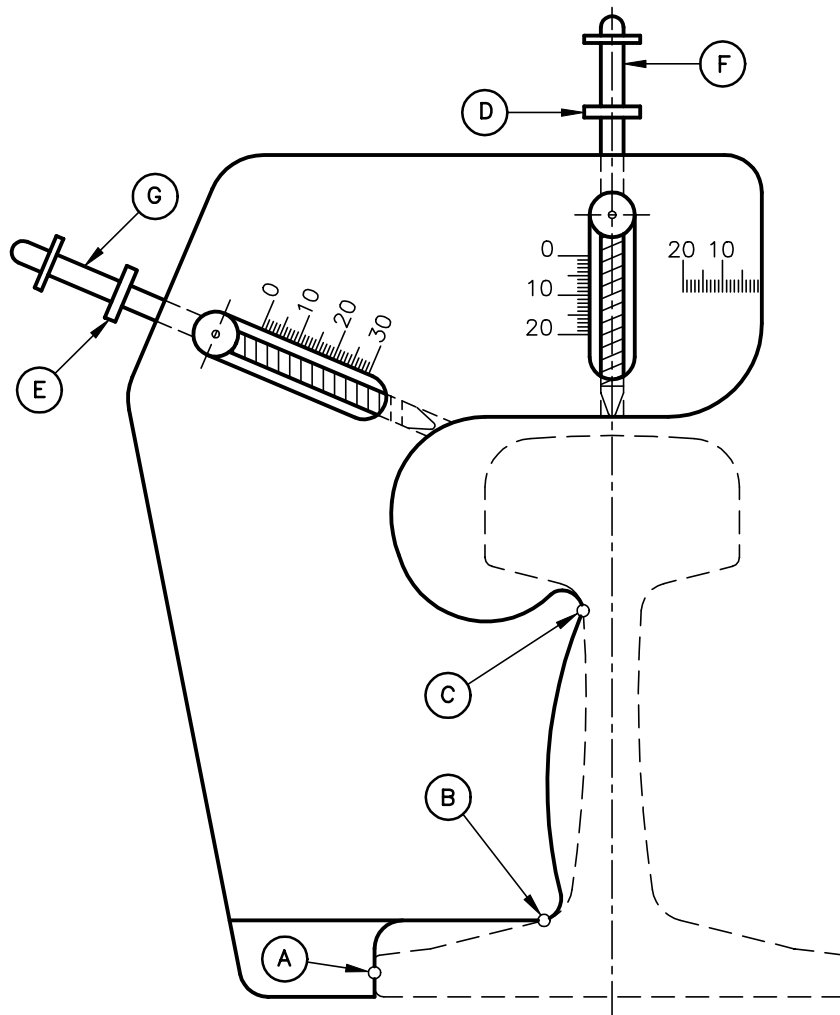

REMARKS:

1. POSITION GAUGE, ENSURING THAT POINTS **A, B & C** MAKE CONTACT WITH THE RAIL.
2. ENSURE THAT STOPPERS **D & E** ARE FIRMLY PRESSED AGAINST THE FRAME OF THE GAUGE.
3. ENSURE THAT THE GAUGE IS SQUARE TO THE RAIL, BY CAREFUL POSITIONING OF THE EXTENSION PIECE AT POINT **A**.
4. DEPRESS SPRING-LOADED SHAFTS **F & G** UNTIL CONTACT IS MADE WITH THE RAIL HEAD.
5. REMOVE THE GAUGE, DEPRESS THE SPRING LOADED SHAFTS UNTIL THE STOPPERS TOUCH THE GAUGE FRAME AND TAKE READINGS FOR TOP AND SIDE WEAR.
6. ALWAYS REMEMBER TO PRESS THE STOPPERS FIRMLY AGAINST THE FRAME BEFORE THE NEXT READINGS ARE TAKEN.
7. FOR RAIL CLASSIFICATION TABLES SEE ANNEXURE 15 SHEET 2.
8. THE CORRECT GAUGE FOR EACH RAIL PROFILE MUST BE USED.
9. WHERE EXCESSIVE CROWN WEAR OCCUR PIN **G** MAY BE REPLACED WITH PIN WITH A L-SHAPED POINT.

RAIL CLASSIFICATION TABLE

CLASS	A-WHITE		B-YELLOW		C-BLUE		D-GREY		
MINIMUM LENGTH	3m		3m		10m		2m		
KINKS (SHORT TWISTED PARTS AND PARTS WITH EXCESSIVE SIDE WEAR MAY BE CUT OFF OR OUT)	NONE		NONE		NONE		NONE		
CORRUGATIONS (MAXIMUM DEPTH) (1,5m STRAIGHT EDGE)	NONE		1mm		2mm		NO LIMIT		
LONGITUDINAL GROOVE IN CROWN (MAXIMUM DEPTH)	NONE		NONE		2mm		NO LIMIT		
CORROSION IN WEB OR FLANGE	SLIGHT		SLIGHT		ORANGE PEEL		LEMON PEEL		
SKID MARKS	NONE		1/3m AND <1mm DEEP		NO LIMIT <2mm DEEP		NO LIMIT		
BENT WEB	NONE		NONE		SLIGHT		LIGHT		
TWISTED RAIL	NONE		NONE		NONE		NONE		
CHAIR IMPRINTS (MAXIMUM DEPTH)	1mm		2mm		2mm		NO LIMIT		
OLD THERMIT AND FLASH-BUTT WELDED JOINTS (MUST BE CUT OUT)	NONE		NONE		NONE		NONE		
CONVEX OR CONCAVE FLASH-BUTT WELDED JOINTS (1,5m STRAIGHT EDGE)	NONE		NONE		UP TO 1,5mm		UP TO 3mm		
BATTERED ENDS (MUST BE CUT OFF FOR CLASSES A, B AND C)	NONE		NONE		NONE		NO LIMIT		
VISIBLE CRACKS	NONE		NONE		NONE		NONE		
		(kg/m)	(mm)	(kg/m)	(mm)	(kg/m)	(mm)	(kg/m)	(mm)
MAXIMUM CROWN WEAR	S-60	-	-	-	-	8,00	15,5	-	-
	UIC-60	-	-	-	-	8,30	16,6	-	-
	57kg	4,05	8,5	6,15	12,3	8,35	16,3	10,20	19,6
	48kg	3,25	7,4	5,05	10,7	6,80	13,8	8,55	17,0
	40kg	2,68	6,0	4,08	8,8	5,33	11,3	6,55	13,8
	30kg	2,08	4,8	3,05	7,0	4,05	9,3	5,03	11,5
MAXIMUM SIDE WEAR	S-60	-	-	-	-	6,10	26,3	-	-
	UIC-60	-	-	-	-	6,60	28,5	-	-
	57kg	0,85	5,2	3,80	16,2	7,20	27,4	7,55	28,5
	48kg	0,75	4,6	2,60	12,6	5,20	23,2	5,65	25,0
	40kg	0,73	5,0	2,00	11,0	3,80	17,1	4,70	20,0
	30kg	0,50	4,1	1,30	8,0	2,50	12,8	3,28	15,8
MAXIMUM COMBINED WEAR	S-60	-	-	-	-	12,10	-	-	-
	UIC-60	-	-	-	-	11,70	-	-	-
	57kg	-	-	-	-	12,50	-	13,40	-
	48kg	-	-	-	-	10,20	-	11,30	-
	40kg	-	-	-	-	7,40	-	8,80	-
	30kg	-	-	-	-	5,00	-	5,90	-

CUTTING OF RELEASED RAILS
FOR RE-USE

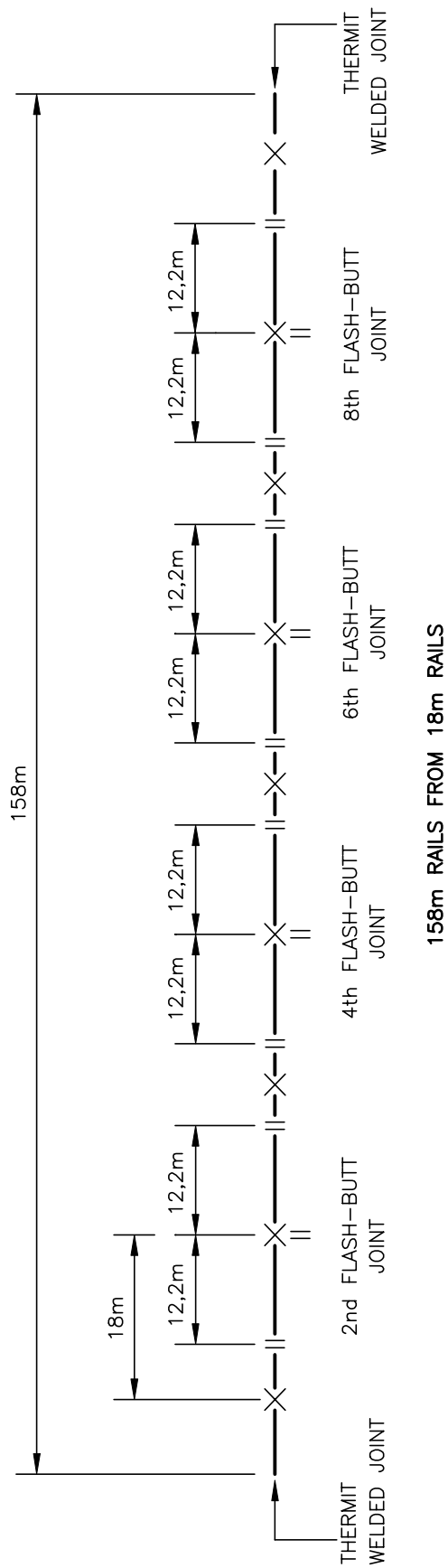
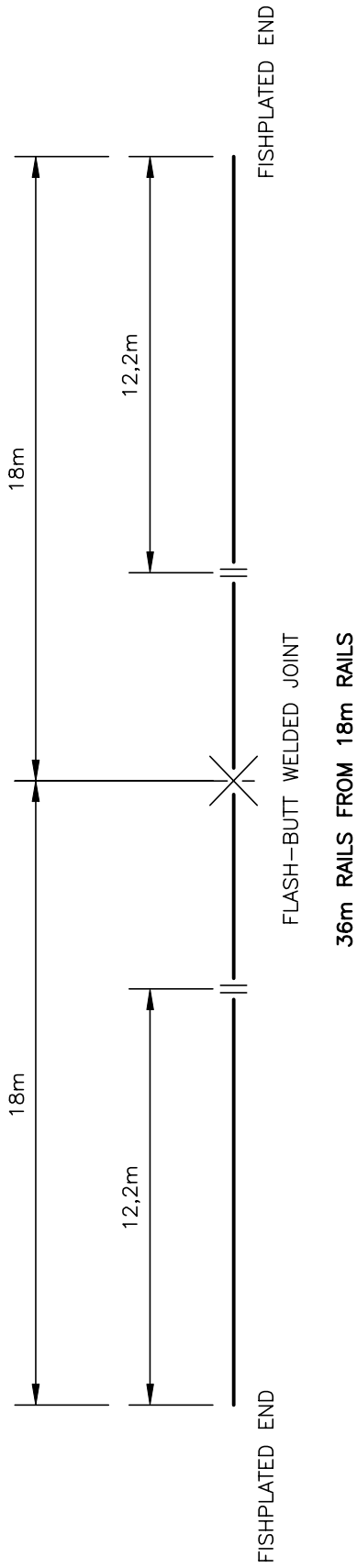

REMARKS:

1. FLASH-BUTT WELDED JOINT.
2. SITE CUTTING (THROUGH FLASH-BUTT JOINT).
3. SITE CUTTING (THROUGH RAIL).

EXPANSION GAPS FOR DIFFERENT
RAIL LENGTHS AND TEMPERATURES

RAIL LENGTH									
9 AND 10m		12m		18m		36m			
TEMP. (°C)	GAP (mm)	TEMP. (°C)	GAP (mm)	TEMP. (°C)	GAP (mm)	TEMP. (°C)	HIGH RULING TEMPERATURE	MODERATE RULING TEMPERATURE	GAP (mm)
-5 TO 10	7	-5 TO 10	8	-5 TO 5	12	10 TO 20	15	5 TO 15	15
11 TO 25	5	11 TO 20	7	6 TO 20	9	21 TO 30	12	16 TO 20	12
26 TO 40	3	21 TO 30	5	21 TO 30	6	31 TO 35	9	21 TO 25	9
41 TO 50	1	31 TO 40	3	31 TO 45	3	36 TO 45	6	26 TO 35	6
51 AND HIGHER	0	41 TO 50	1	46 AND HIGHER	0	46 TO 50	3	36 TO 40	3
-	-	51 AND HIGHER	0	-	-	51 TO 60	0	41 TO 50	0

REMARKS:

1. FOR LIST OF SECTIONS OF LINE FALLING WITHIN MODERATE RULING TEMPERATURE AREAS, SEE ANNEXURE 16 SHEET 2.

SECTIONS WITH MODERATE RULING TEMPERATURES

MAKWASSIE – VERMAAS
VERMAAS – PUDIMOE
KLERKSDORP – OTTOSDAL
WELVERDIEND – LICHTENBURG
VERMAAS – COLIGNY

BOWKERSPARK – SPRINGFONTEIN
STERKSTROOM – MACLEAR
MOLTENO – JAMESTOWN
STORMBERG – ROSMEAD
SCHOOMBEE – HOFMEYR
DREUNBERG – ALIWAAL NORTH
ALIWAAL NORTH – BARKLY EAST

NOUPOORT – BLOEMFONTEIN
SPRINGFONTEIN – KOFFIEFONTEIN
HAMILTON – DE BRUG
BLOEMFONTEIN – BETHLEHEM
SANNASPOS – ALIWAAL NORTH
MARSAILLES – MASERU
MODDERPOORT – LADYBRAND
BETHLEHEM – HARRISMITH
HARRISMITH – WARDEN
BETHLEHEM – GROOTVLEI
ARLINGTON – WOLWEHOEK
ARLINGTON – MARQUARD
ARLINGTON – GUNHILL
THEUNISSEN – WINBURG
VIRGINIA – GLEN HARMONY
WHITES – ODENDALSRSUS
BLOEMFONTEIN – VEREENIGING
ALLANRIDGE – ANCONA
BULTFONTEIN – VIERFONTEIN
WESTLEIGH – ORKNEY
DOVER – VREDEFORT

PORT SHEPSTONE – UMKOMAAS
KELSO – UMZINTO
LIDGETTON – ESTCOURT
INGOGO – VOLKSRUST
FRANKLIN – MATATIELE
ENNERSDALE – BERGVILLE
BRAKWAAL – VAN REENEN
COMMONDAL – PIET RETIEF

VOLKSRUST – UNION
VOLKSRUST – BREYTEN
BALFOUR NORTH – DROËBULT
GROOTVLEI – REDAN
KAYDALE – SPRINGS
SPRINGS – BETHAL
SPRINGS – NATALSPRUIT
GERMISTON – KWESINE
GERMISTON – ELSBURG
VEREENIGING – BANK
HOUTHEUWEL – FOCHVILLE
MIDWAY – INDIA
MIDWAY – LANGLAAGTE
NALEDI – NEW CANADA
CITY DEEP – LANGLAAGTE
CITY DEEP – WESTGATE
BOOYSENS – FARADAY
BOOYSENS – TRANSRAND
JUPITER – DRIEHOEK
DRIEHOEK – INDIA
GERMISTON – SPRINGS

GERMISTON – CHACHET
KRUGERSDORP – WOODBINE
GERMISTON – PRETORIA
LERALLA – OAKMOOR
DUNSWART – APEX
DUNSWART – WELGEDAG
SPRINGS – WITBANK
ALLIANCE – DAVEYTON
DELMAS – HAWERKLIP
OGIES – BROODSNYERSPLAAS

PRETORIA – RIVULETS
BELFAST – LYDENBURG
MACHADODORP – PIET RETIEF
SABIE – GRASKOP
POTGIETERSRUS – SOLOMONDALE
HERCULUS – MAGALIESBURG
NYLSTROOM – VAALWATER
BROODSNYERSPLAAS – ERMELO

KALBASKRAAL – SALDANHA
SALDANHA – BAMBOESBAAI

REMARKS:

1. ALL OTHER SECTIONS MUST BE REGARDED AS SECTIONS FALLING WITHIN THE HIGH RULING TEMPERATURE AREAS.

DESTRESSING AND WORKING
TEMPERATURE RANGES

SECTION	DESTRESSING RANGES		WORKING RANGES FOR RAIL LAYING	
	THROUGH LINES	YARD TRACKS	B	C
	A	D		
CAPE TOWN – BELLVILLE	20 – 50	25 – 45	15 – 55	15 – 60
* BELLVILLE – WORCESTER	25 – 45	30 – 40	20 – 50	20 – 60
* WORCESTER – DE AAR	25 – 40	25 – 35	20 – 50	20 – 55
HUTCHINSON – CALVINIA	25 – 35	25 – 30	20 – 40	20 – 50
KOOTJIESKOLK – SAKRIVIER	25 – 35	25 – 30	20 – 40	20 – 50
KRAAIFONTEIN – BITTERFONTEIN	25 – 45	30 – 40	20 – 50	20 – 60
KALBASKRAAL – SALDANHA	25 – 45	30 – 40	20 – 50	20 – 60
HERMON – PORTERVILLE	25 – 45	30 – 40	20 – 50	20 – 60
WOLSELEY – PRINCE ALFRED HAMLET	25 – 45	30 – 40	20 – 50	20 – 60
PAARL – FRANCHHOEK	25 – 45	30 – 40	20 – 50	20 – 60
EERSTERIVIER – BREDASDORP	25 – 45	30 – 40	20 – 50	20 – 60
VAN DER STEL – STRAND	25 – 45	30 – 40	20 – 50	20 – 60
KLIPDALE – PROTEM	25 – 45	30 – 40	20 – 50	20 – 60
EERSTERIVIER – MULDERSVLEI	25 – 45	30 – 40	20 – 50	20 – 60
* WORCESTER – RIVERSDALE	25 – 40	30 – 35	20 – 45	20 – 55
KENTEMADE – ATLANTIS	25 – 45	30 – 40	20 – 50	20 – 60
TABLE BAY HARBOUR – SIMONSTOWN	20 – 50	25 – 45	15 – 55	15 – 60
CAPE TOWN CENTRAL METRO AREA	20 – 50	25 – 45	15 – 55	15 – 60
* DE AAR – * KIMBERLEY	25 – 35	25 – 30	20 – 40	20 – 50
* KIMBERLEY – MAKWASSIE	25 – 40	30 – 40	20 – 50	20 – 55
* MAKWASSIE – * KLERKSDORP	20 – 40	25 – 35	15 – 50	15 – 55
* KIMBERLEY – * POSTMASBURG	25 – 35	25 – 30	20 – 40	20 – 50
POSTMASBURG – HOTAZEL	25 – 40	30 – 35	20 – 45	20 – 55
DE AAR – NAKOP	25 – 40	30 – 35	25 – 45	25 – 55
GROVEPUT – COPPERTON	25 – 40	30 – 35	25 – 45	20 – 55
UPINGTON – KAKEMAS	25 – 40	30 – 35	25 – 45	20 – 55
BELMONT – DOUGLAS	25 – 40	30 – 35	20 – 45	20 – 55
VEERTIENSTROME – MAFIKENG	25 – 40	30 – 35	20 – 45	20 – 55
PUDIMOE – COLIGNE	25 – 40	30 – 35	20 – 45	20 – 55
* MAKWASSIE – VERMAAS	20 – 40	25 – 35	15 – 45	15 – 55
OTTOSDAL – * KLERKSDORP	20 – 40	25 – 35	15 – 45	15 – 55
LICHTENBURG – WELVERDIEND	20 – 40	25 – 35	15 – 45	15 – 55
PORT ELIZABETH – ALICEDALE	25 – 45	30 – 40	20 – 50	20 – 60
* ALICEDALE – NOUPOORT	25 – 40	30 – 35	20 – 45	20 – 55
NOUPOORT – DE AAR	25 – 40	30 – 35	20 – 45	20 – 55
SWARTKOPS – KLIPPLAAT	25 – 45	30 – 40	20 – 50	20 – 60
KLIPPLAAT – ROSMEAD	25 – 45	30 – 40	20 – 50	20 – 60
ADDO – KIRKWOOD	25 – 45	30 – 40	20 – 50	20 – 60
RIVERSDALE – * MOSSELBAAI	25 – 45	30 – 40	20 – 50	20 – 60
MOSSELBAAI – GEORGE	20 – 45	25 – 40	15 – 50	15 – 60
* GEORGE – OUDTSHOORN	25 – 45	30 – 40	20 – 50	20 – 60
* OUDTSHOORN – * KLIPPLAAT	25 – 40	30 – 35	20 – 45	20 – 55
OUDTSHOORN – CALITZDORP	25 – 45	30 – 40	20 – 50	20 – 60
* GEORGE – KNYSNA	25 – 45	30 – 40	20 – 50	20 – 60
* PORT ELIZABETH – AVONTUUR	25 – 40	30 – 35	20 – 45	20 – 55
GAMTOOS – PATENSIE	25 – 45	30 – 40	20 – 50	20 – 60
COOKHOUSE – SOMERSET EAST	25 – 40	30 – 35	20 – 45	20 – 55
* ALICEDALE – PORT ALFRED	30 – 40	30 – 35	25 – 45	25 – 55
BARKLEY BRIDGE – ALEXANDRIA	25 – 45	30 – 40	20 – 50	20 – 60
EAST LONDON – DOHNE	20 – 45	25 – 40	15 – 50	15 – 60
* DOHNE – QUEENSTOWN	25 – 40	30 – 35	20 – 50	20 – 55
* QUEENSTOWN – BURGERSDORP	20 – 35	25 – 30	15 – 45	15 – 50
* BURGERSDORP – SPRINGFONTEIN	20 – 40	25 – 40	15 – 50	15 – 55
COOKHOUSE – BLANEY	25 – 40	30 – 35	20 – 45	20 – 55
AMABELE – UMTATA	25 – 40	30 – 35	20 – 45	20 – 55
IMVANI – QAMATA	25 – 40	30 – 35	20 – 45	20 – 55
* ROSMEAD – STORMBERG	20 – 30	20 – 25	15 – 35	15 – 45
SCHOOMBEE – HOFMEYR	20 – 30	20 – 25	15 – 35	15 – 45
STERKSTROOM – MACLAER	20 – 30	20 – 25	15 – 35	15 – 45
MOLTENO – JAMESTOWN	20 – 30	20 – 25	15 – 35	15 – 45
BURGERSDORP – BARKLEY EAST	20 – 35	25 – 30	15 – 40	15 – 50

REMARKS:

1. FOR REMARKS SEE ANNEXURE 16 SHEET 5.

DESTRESSING AND WORKING
TEMPERATURE RANGES

SECTION	DESTRESSING RANGES		WORKING RANGES FOR RAIL LAYING	
	THROUGH LINES	YARD TRACKS	B	C
	A	D		
NOUPOORT – SPRINGFONTEIN	20 – 40	25 – 35	15 – 45	15 – 55
* SPRINGFONTEIN – BLOEMFONTEIN	20 – 35	25 – 30	15 – 40	15 – 50
BLOEMFONTEIN – THEUNISSEN	20 – 35	25 – 30	15 – 40	15 – 50
* THEUNISSEN – KROONSTAD	20 – 40	25 – 35	15 – 45	15 – 55
KROONSTAD – VEREENIGING	20 – 40	25 – 35	15 – 45	15 – 55
BETHLEHEM – ARLINGTON	15 – 35	20 – 30	10 – 40	10 – 50
* ARLINGTON – * KROONSTAD	15 – 40	20 – 35	10 – 45	10 – 55
KIMBERLEY – EMMAUS	25 – 40	25 – 35	20 – 45	20 – 55
* EMMAUS – BLOEMFONTEIN	20 – 35	25 – 30	15 – 40	15 – 50
SPRINGFONTEIN – KOFFIEFONTEIN	25 – 40	30 – 35	20 – 45	20 – 55
ALIWAL NORTH – SANNASPOS	20 – 40	25 – 35	15 – 45	15 – 55
GROOTVLEI – * BETHLEHEM	20 – 35	25 – 30	15 – 40	15 – 50
* BETHLEHEM – BLOEMFONTEIN	20 – 35	25 – 30	15 – 40	15 – 50
HARRISMITH – BETHLEHEM	15 – 35	20 – 30	10 – 40	10 – 50
VREDEFORT – DOVER	20 – 40	25 – 35	15 – 45	15 – 55
WOLWEHOEK – ARLINGTON	20 – 40	25 – 35	15 – 45	15 – 55
* ARLINGTON – MARQUARD	20 – 40	25 – 35	15 – 45	15 – 55
ORKNEY – WESLEIGH	20 – 40	25 – 35	15 – 45	15 – 55
VIERFONTEIN – BULTFONTEIN	20 – 40	25 – 35	15 – 45	15 – 55
ANCONA – WHITES	20 – 40	25 – 35	15 – 45	15 – 55
THEUNISSEN – WINBURG	20 – 40	25 – 35	15 – 45	15 – 55
WARDEN – * HARRISMITH	20 – 40	25 – 35	15 – 45	15 – 55
MASERU – MARSAILLES	20 – 40	25 – 35	15 – 45	15 – 55
LADYBRAND – MODDERPOORT	20 – 40	25 – 35	15 – 45	15 – 55
VIRGINIA – GLEN HARMONY	20 – 40	25 – 35	15 – 45	15 – 55
WONDERFONTEIN – BROODSNYERSPLAAS	15 – 40	20 – 35	10 – 45	10 – 55
ERMELO – MACHADODORP	20 – 40	25 – 35	15 – 45	15 – 55
BUHRMANNSKOP – LOTHAIR	15 – 35	20 – 30	10 – 40	10 – 50
ROSSBURG – * DASSENHOEK	20 – 45	25 – 40	15 – 50	15 – 60
DASSENHOEK – CATO RIDGE	25 – 40	30 – 35	20 – 45	20 – 55
CATO RIDGE – PIETERMARITZBURG	25 – 40	30 – 35	20 – 45	20 – 55
* PIETERMARITZBURG – * VOLKSRUST	20 – 40	25 – 35	15 – 45	15 – 55
ROSSBURG – HILLCREST	20 – 45	25 – 40	15 – 50	15 – 60
* HILLCREST – CATO RIDGE	25 – 40	30 – 35	20 – 45	20 – 55
DURBAN – PORT SHEPSTONE	20 – 50	25 – 45	15 – 60	15 – 65
KELSO – UMZINTO	20 – 50	25 – 45	15 – 60	15 – 65
DURBAN – HLUHLUWE	20 – 50	25 – 45	15 – 60	15 – 65
* HLUHLUWE – GOLELA	25 – 45	30 – 40	20 – 55	20 – 60
EMPANGENI – NKWALINI	25 – 50	30 – 45	20 – 55	20 – 60
DUFFSROAD – KWAMASHU	25 – 50	30 – 45	20 – 55	20 – 60
THORNVILLE – RICHMOND	25 – 40	30 – 35	20 – 45	20 – 55
THORNVILLE – PENTRICH	25 – 40	30 – 35	20 – 45	20 – 55
* PIETERMARITZBURG – KOKSTAD	25 – 35	25 – 30	20 – 40	20 – 50
DONNYBROOK – UNDERBERG	20 – 35	25 – 30	15 – 40	15 – 50
FRANKLIN – MATATIELE	20 – 35	25 – 30	15 – 40	15 – 50
PIETERMARITZBURG – DALTON	25 – 40	30 – 35	20 – 45	20 – 55
* DALTON – KRANSKOP	20 – 40	25 – 35	15 – 45	15 – 55
SCHROEDERS – BRUYNSHILL	25 – 40	30 – 35	20 – 45	20 – 55
* DALTON – GLENSIDE	20 – 40	25 – 35	15 – 45	15 – 55
GREYTOWN – MOUNT ALIDA	20 – 40	25 – 35	15 – 45	15 – 55
ENNERSDALE – BERGVILLE	25 – 40	30 – 35	20 – 45	20 – 55
GLENCOE – VRYHEID	20 – 40	20 – 35	15 – 50	15 – 55
NEWCASTLE – UTRECHT	20 – 40	25 – 35	15 – 45	15 – 55
LADYSMITH – HARRISMITH	20 – 40	25 – 35	15 – 45	15 – 55

REMARKS:

1. FOR REMARKS SEE ANNEXURE 16 SHEET 5.

DESTRESSING AND WORKING
TEMPERATURE RANGES

SECTION	DESTRESSING RANGES		WORKING RANGES FOR RAIL LAYING	
	THROUGH LINES	YARD TRACKS	B	C
	A	D		
KLERKSDORP – * POTCHEFSTROOM	20 – 35	25 – 30	20 – 40	15 – 50
POTCHEFSTROOM – * KRUGERSDORP	20 – 40	25 – 35	15 – 45	15 – 55
KRUGERSDORP – JOHANNESBURG	15 – 40	20 – 35	10 – 45	10 – 55
JOHANNESBURG – OLIFANTSFONTEIN	15 – 40	20 – 35	10 – 45	10 – 55
POTCHEFSTROOM – VEREENIGING	20 – 40	25 – 35	15 – 45	15 – 55
VEREENIGING – GERMISTON	20 – 40	25 – 35	15 – 45	15 – 55
VOLKSRUST – * STANDERTON	15 – 35	20 – 30	10 – 40	10 – 50
STANDERTON – * HEIDELBERG	20 – 35	25 – 30	15 – 40	15 – 50
HEIDELBERG – GERMISTON	20 – 40	25 – 35	15 – 45	15 – 55
BALFOUR NORTH – * GROOTVLEI	20 – 35	25 – 30	15 – 40	15 – 50
GROOTVLEI – REDAN	20 – 40	25 – 35	15 – 45	15 – 55
FIRHAM – VREDE	20 – 35	25 – 30	15 – 40	15 – 50
VOLKSRUST – BREYTEN	15 – 40	20 – 35	10 – 45	10 – 55
BETHAL – SPRINGS	20 – 40	25 – 35	15 – 45	15 – 55
SPRINGS – KAYDALE	20 – 40	25 – 35	15 – 45	15 – 55
MIDWAY – HOUTHEUWEL	20 – 35	25 – 30	15 – 40	15 – 50
BANK – LANGLAAGTE	20 – 35	25 – 30	15 – 40	15 – 50
MAFIKENG – * KRUGERSDORP	25 – 40	30 – 35	20 – 45	20 – 55
APEX – WITBANK	20 – 35	25 – 30	15 – 40	15 – 50
DELMAS – HAWEKLIJF	20 – 35	25 – 30	15 – 40	15 – 50
SENTRARAND AREA	15 – 35	20 – 30	10 – 40	10 – 50
JOHANNESBURG CENTRAL METRO AREA	15 – 40	20 – 35	10 – 45	10 – 55
OLIFANTSFONTEIN – * IRENE	15 – 40	20 – 35	10 – 45	10 – 55
IRENE – PRETORIA	20 – 40	25 – 35	15 – 45	15 – 55
PRETORIA – * WARMBATHS	20 – 40	25 – 35	15 – 45	15 – 55
WARMBATHS – * POTGIETERSRUS	20 – 45	25 – 40	15 – 55	15 – 60
POTGIETERSRUS – BEITBRIDGE	20 – 45	25 – 40	15 – 50	15 – 50
* PRETORIA – * WATERVAL BOVEN	20 – 40	25 – 35	15 – 50	15 – 55
WATERVAL BOVEN – * NELSPRUIT	20 – 45	25 – 40	15 – 55	15 – 60
NELSPRUIT – KOMATIPOORT	25 – 45	30 – 40	20 – 55	20 – 60
HERCULES – MAGALIESBURG	20 – 40	25 – 35	15 – 45	15 – 55
PRETORIA – BRITS	20 – 40	20 – 35	15 – 45	15 – 55
BRITS – RUSTENBURG	20 – 40	25 – 35	15 – 45	15 – 55
RUSTENBURG – * THABAZIMBI	20 – 40	25 – 35	15 – 45	15 – 55
THABAZIMBI – ELLISRAS	25 – 40	30 – 35	20 – 45	20 – 55
BRITS – ATLANTA	20 – 40	25 – 35	15 – 45	15 – 55
NYLSTROOM – VAALWATER	20 – 40	25 – 35	15 – 45	15 – 55
NABOOMSPRUIT – ZEBEDIELA	20 – 40	25 – 35	15 – 45	15 – 55
PIENAARSRIVIER – MARBLE HALL	25 – 40	30 – 35	20 – 45	20 – 55
RAYTON – CULLINAN	20 – 40	25 – 35	15 – 45	15 – 55
GROENBULT – KAAPMUIDEN	25 – 45	30 – 40	20 – 50	20 – 60
HOEDSPRUIT – PHALABORWA	25 – 45	30 – 40	20 – 50	20 – 60
* KAAPMUIDEN – BARBERTON	20 – 45	25 – 40	15 – 50	15 – 60
* NELSPRUIT – GRASKOP	20 – 35	25 – 30	15 – 40	15 – 50
CITRUS – PLASTON	20 – 45	25 – 40	15 – 50	15 – 60
BELFAST – STEELPOORT	20 – 40	25 – 35	15 – 45	15 – 55
DERWENT – ROOSSENEKAL	20 – 40	25 – 35	15 – 45	15 – 55
PRETORIA CENTRAL METRO AREA	20 – 40	25 – 35	15 – 45	15 – 55
SALDANHA – BAMBOESBAAI	20 – 50	25 – 45	15 – 55	15 – 60
* BAMBOESBAAI – SISHEN	25 – 40	30 – 35	20 – 45	20 – 55
RICHARDSBAY – ULUNDI	20 – 45	–	20 – 55	–
* ULUNDI – PIET RETIEF	20 – 40	25 – 35	20 – 50	15 – 55
PIET RETIEF – * SHEEPMORE	20 – 40	25 – 35	20 – 50	15 – 55
SHEEPMORE – ERMELO	15 – 35	20 – 30	15 – 45	10 – 50
* ERMELO – BROODSNYERSPLAAS	15 – 40	20 – 35	15 – 50	10 – 55
BROODSNYERSPLAAS – OGIES	15 – 40	20 – 35	15 – 50	10 – 55

REMARKS:

1. RAIL TEMPERATURES IN DEGREE CELSIUS.
2. USE A RAIL TENSOR WHEN THE DIFFERENCE IN THE 'A' RANGE IS 10° CELSIUS OR SMALLER.
3. * DENOTES "EXCLUDED".

TYPICAL RAIL DEFECTS AND FRACTURES

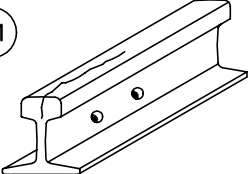
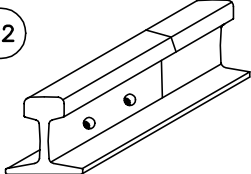
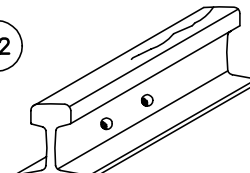
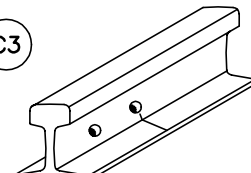
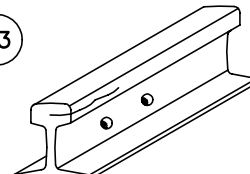
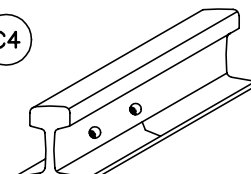
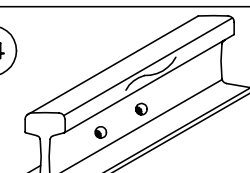
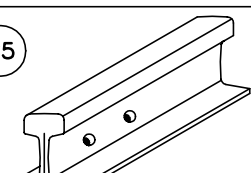
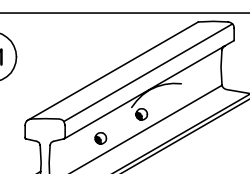
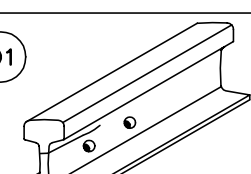
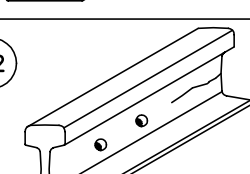
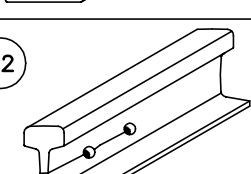
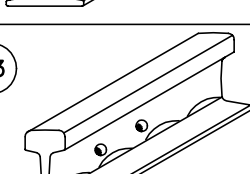
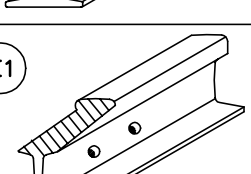
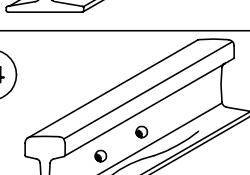
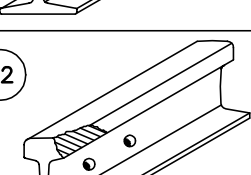
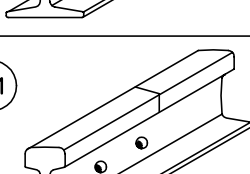
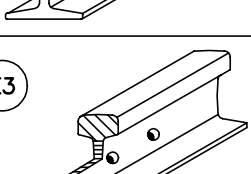
	<p>A1</p> <p>VERTICAL CRACK THROUGH CROWN AT END.</p>		<p>C2</p> <p>TRANSVERSE CRACK ACROSS HEAD ORIGINATING FROM TRACK BOND.</p>
	<p>A2</p> <p>CRACK THROUGH CROWN OF RAIL IN RUNNING SURFACE.</p>		<p>C3</p> <p>TRANSVERSE CRACK ACROSS FLANGE ORIGINATING FROM TRACK BOND.</p>
	<p>A3</p> <p>HORIZONTAL CRACK IN HEAD OF RAIL AT END.</p>		<p>C4</p> <p>TRANSVERSE CRACK ACROSS FLANGE.</p>
	<p>A4</p> <p>HORIZONTAL CRACK IN SIDE OF HEAD OF RAIL.</p>		<p>C5</p> <p>VERTICAL CRACK IN SECTION OF RAIL AT END.</p>
	<p>B1</p> <p>CRACK ALONG RAIL AT JUNCTION OF HEAD AND WEB.</p>		<p>D1</p> <p>CRACK IN WEB OF RAIL AT END.</p>
	<p>B2</p> <p>HORIZONTAL CRACK IN BODY OF WEB.</p>		<p>D2</p> <p>CRACK IN WEB ALONG FISH-BOLT HOLES.</p>
	<p>B3</p> <p>CRACKS AT JUNCTION OF WEB AND FLANGE (OVER SLEEPERS).</p>		<p>E1</p> <p>PIECE OF CROWN BROKEN AWAY AT END.</p>
	<p>B4</p> <p>CRACK ALONG FLANGE OF RAIL.</p>		<p>E2</p> <p>PIECE BROKEN AWAY FROM SIDE OF HEAD AT END.</p>
	<p>C1</p> <p>TRANSVERSE CRACK ACROSS HEAD.</p>		<p>E3</p> <p>HEAD OF RAIL BROKEN AWAY AT END.</p>

TYPICAL RAIL DEFECTS AND FRACTURES

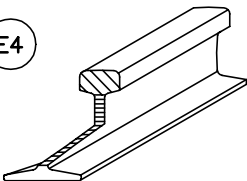
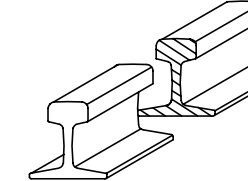
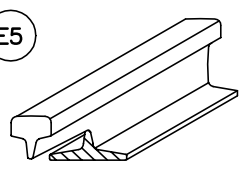
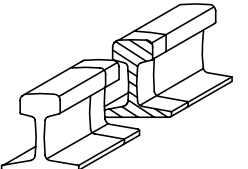
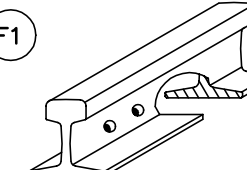
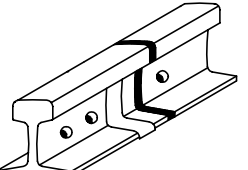
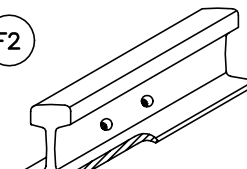
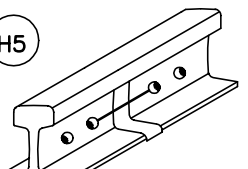
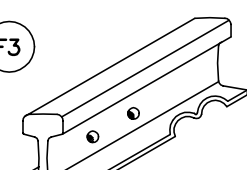
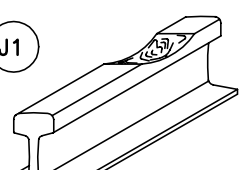
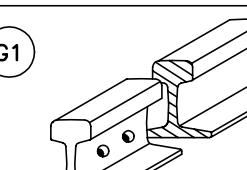
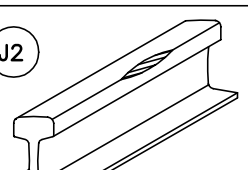
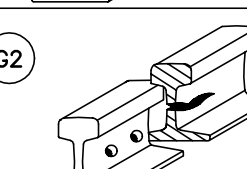
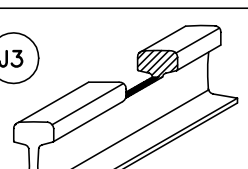
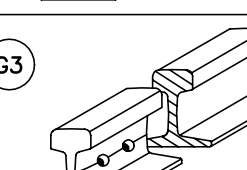
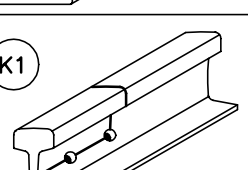
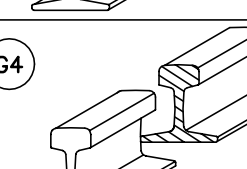
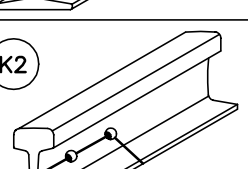
	<p>E4</p> <p>PORTION OF HEAD AND WEB OF RAIL BROKEN AWAY AT END.</p>		<p>H1 BREAK THROUGH FLASH-BUTT WELD.</p> <p>H4 BREAK THROUGH ARC-BUTT WELD.</p>
	<p>E5</p> <p>PORTION OF WEB AND FLANGE OF RAIL BROKEN AWAY AT END.</p>		<p>H2 BREAK THROUGH THERMIT WELD.</p> <p>H6 BREAK THROUGH THERMIT WELD AT JUNCTION RAIL.</p>
	<p>F1</p> <p>PORTION OF WEB AND FLANGE OF RAIL BROKEN OUT.</p>		<p>H3 BREAK THROUGH RAIL ADJACENT TO THERMIT WELD.</p> <p>H7 BREAK THROUGH RAIL ADJACENT TO THERMIT WELD AT JUNCTION RAIL.</p>
	<p>F2</p> <p>PORTION OF FLANGE BROKEN AWAY AT END.</p>		<p>H5</p> <p>CRACK ACROSS THERMIT WELD.</p>
	<p>F3</p> <p>PIECE OF FLANGE BROKEN OUT.</p>		<p>J1</p> <p>RAIL DAMAGED BY SPINNING WHEELS.</p>
	<p>G1</p> <p>BREAK THROUGH SECTION OF RAIL.</p>		<p>J2</p> <p>PIECE BROKEN OUT FROM SIDE OF HEAD.</p>
	<p>G2</p> <p>BREAK THROUGH SECTION OF RAIL AND LONGITUDINAL CRACK IN WEB.</p>		<p>J3</p> <p>PORTION BROKEN OUT OF HEAD OF RAIL.</p>
	<p>G3</p> <p>BREAK THROUGH HEAD AND FLANGE OF RAIL WITH CRACKS EXTENDING INTO THE FISH-BOLT HOLES.</p>		<p>K1</p> <p>PIECE OF HEAD AND WEB BROKEN AWAY THROUGH FISH-BOLT HOLES.</p>
	<p>G4</p> <p>BREAK THROUGH SECTION OF RAIL, ANNEXURE 17 SHEET 3.</p>		<p>K2</p> <p>PIECE OF WEB AND FLANGE BROKEN AWAY THROUGH FISH-BOLT HOLES.</p>

EARLY STAGE

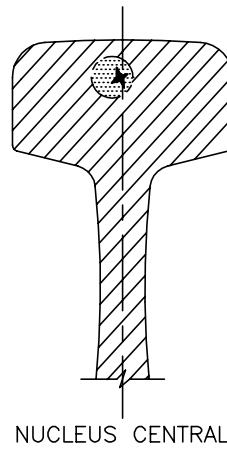
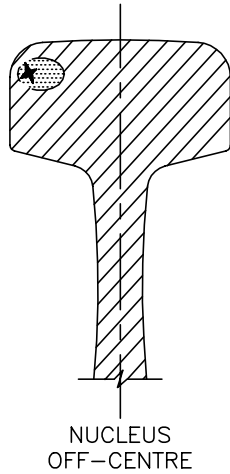

LATE STAGE

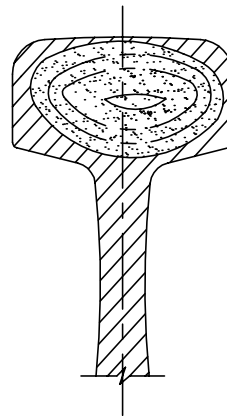
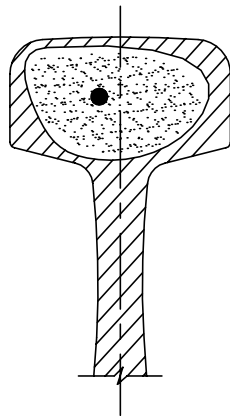

REMARKS:

1. THE TRANSVERSE FISSURE FLAW IS A PROGRESSIVE CROSSWISE FRACTURE STARTING FROM A NUCLEUS INSIDE THE HEAD OF THE RAIL AND SPREADING OUTWARDS UNTIL FRACTURE OF THE RAIL RESULTS. THE FLAW SPREADS MORE QUICKLY AS IT BECOMES LARGER.
2. THE SKETCHES ABOVE INDICATE VARIOUS STAGES OF THE DEVELOPMENT OF TRANSVERSE FISSURES.
3. THIS TYPE OF FLAW IS DANGEROUS AS THE RAIL USUALLY DEVELOPS A NUMBER OF FLAWS AND BREAKS INTO A NUMBER OF PIECES.
4. ULTRASONIC TESTING PROVIDES THE MOST SUCCESSFUL METHOD OF ESTABLISHING THE PRESENCE OF SUCH FISSURES.
5. WHEN CRACKS ACROSS THE HEAD OF A RAIL ARE DISCOVERED, THE RAIL, AFTER REMOVAL FROM THE TRACK, MUST BE BROKEN TO ESTABLISH WHETHER A TRANSVERSE FISSURE FLAW IS THE CAUSE, AND TO WHAT EXTENT IT CORRELATES WITH ULTRASONIC TESTS.

RAIL DEFECTS AND FRACTURES :
SAFETY PRECAUTIONS TO BE OBSERVED

NO RESTRICTIONS (EXCLUDING HEAVY HAUL LINES)

DEFECTS AS ILLUSTRATED, BUT NOT LONGER THAN 150mm

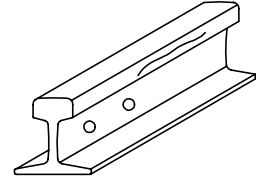
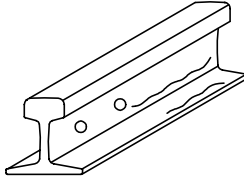
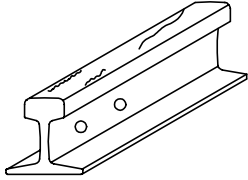

LESS THAN
6mm DEEP

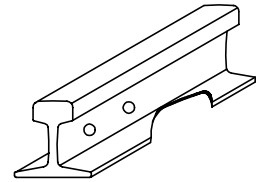
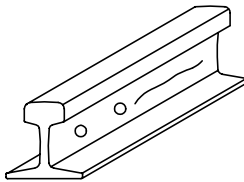
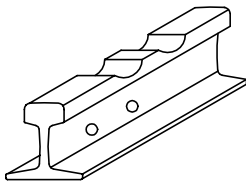

MAXIMUM SPEED 15km/h (EXCLUDING HEAVY HAUL LINES)

DEFECTS AS ILLUSTRATED ABOVE, BUT LONGER
THAN 150mm, PLUS THOSE ILLUSTRATED HERE.

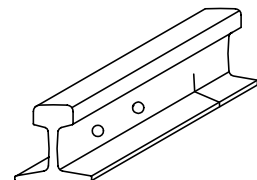
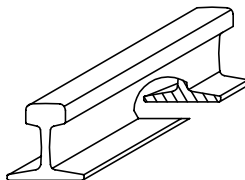
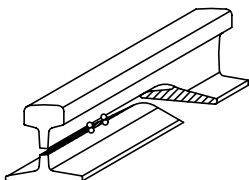
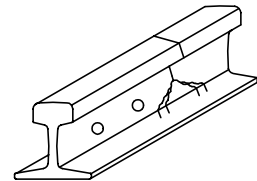
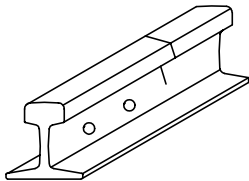



STOP

WAIT FOR PERMANENT WAY STAFF

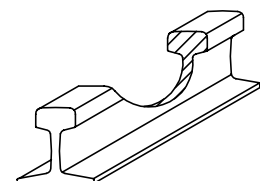
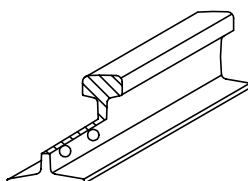
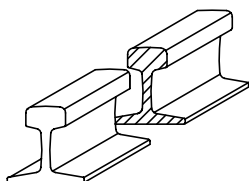
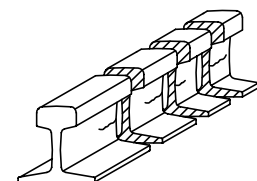
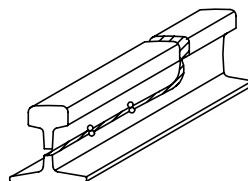
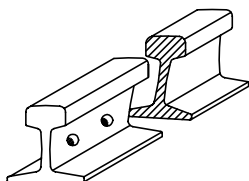
DEFECTS AS ILLUSTRATED AND ALL OTHERS NOT SHOWN.

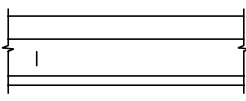
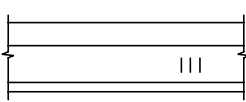
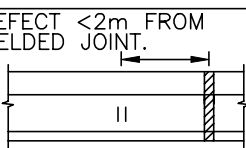
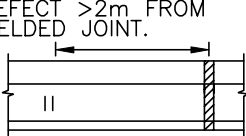
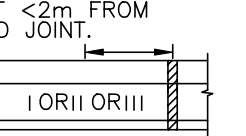
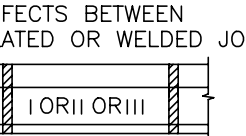
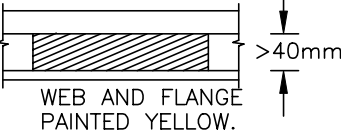

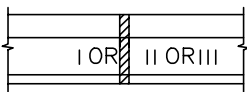
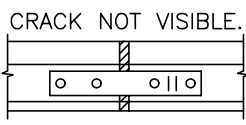
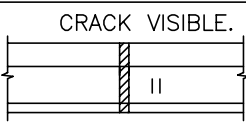
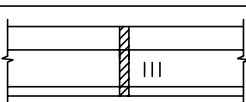
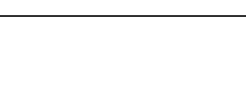
TYPE OF DEFECT	ULTRASONIC MARK	INDICATION OF ULTRASONIC DEFECT	ACTION
TRANSVERSE FISSURE IN RAIL	VERTICAL YELLOW STRIPES PAINTED ON RAIL WEB.  I OR II OR III I = DEFECT < 15mm II = 15 ≤ DEFECT < 25mm III = DEFECT ≥ 25mm	S - LINES 	CUT OUT DEFECT IMMEDIATELY AND REPLACE WITH CLOSURE RAIL.
		N1, N2 AND N3 LINES 	
		DEFECT <2m FROM WELDED JOINT. 	CUT OUT DEFECT AND REPLACE WITH CLOSURE RAIL.
		DEFECT >2m FROM WELDED JOINT. 	STRENGTHEN TEMPORARILY WITH FISHPLATES AND FISHBOLTS OR JOGGLED FISHPLATES.
		DEFECT <2m FROM WELDED JOINT. 	CUT OUT DEFECT AND DEFECTIVE WELDED JOINT AND REPLACE WITH CLOSURE RAIL.
		>1 DEFECTS BETWEEN FISHPLATED OR WELDED JOINT 	CUT OUT AND REPLACE TOTAL LENGTH BETWEEN JOINTS.
PIPING IN RAIL	 WEB AND FLANGE PAINTED YELLOW. >40mm		CUT TOTAL PIPE LENGTH OUT AND REPLACE WITH CLOSURE RAIL.
DEFECT AT FISHPLATED JOINT	 BOTH FISHPLATES PAINTED YELLOW.		REMOVE FISHPLATES AND IF CRACKS ARE VISIBLE, REPLACE THE WHOLE CRACKED RAIL OR PART OF IT WITH CLOSURE RAIL.
DEFECT AT WELDED JOINT	 WEB OF RAIL PAINTED AT THE WELDED JOINT WITH VERTICAL YELLOW STRIPES. (EXCLUDING HEAVY HAUL LINES. SEE CHAPTER 20).	CRACK NOT VISIBLE. 	STRENGTHEN WITH YELLOW PAINTED JOGGLED FISHPLATES.
		CRACK VISIBLE. 	IF CRACKS IS VISIBLE AFTER REMOVAL OF JOGGLED FISHPLATES, CUT OUT AND REPLACE WITH CLOSURE RAIL.
			CUT OUT DEFECT IMMEDIATELY AND REPLACE WITH CLOSURE RAIL.
			

MINIMUM CUT DISTANCE FROM WELDED JOINTS
AND MINIMUM DISTANCE BETWEEN JOINTS

MINIMUM CUT DISTANCE FROM WELDED JOINTS

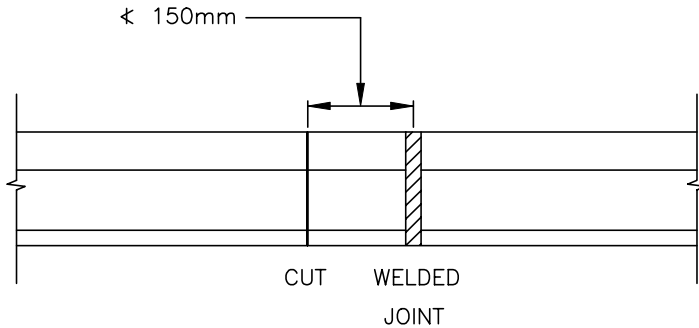

IF WELD IS DEFECTIVE, CUT RAIL NOT CLOSER THAN 150mm FROM THE CENTRE OF AN EXISTING WELDED JOINT. IF WELD IS SOUND, THE CUT MAY BE MADE THROUGH THE WELD.

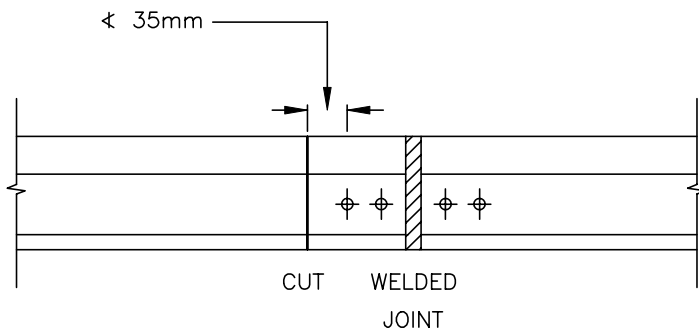

CUT RAIL NOT CLOSER THAN 35mm FROM THE CENTRE OF AN EXISTING FISHPLATE HOLE.

MINIMUM DISTANCE BETWEEN RAIL JOINTS

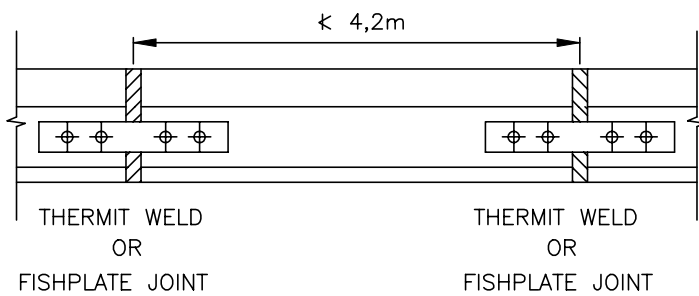

MINIMUM DISTANCE BETWEEN THERMIT WELD/FISHPLATE JOINT AND THERMIT WELD/FISHPLATE JOINT MUST BE AT LEAST 4,2m.

EXCEPT IN THE CASE OF INSULATED JOINTS

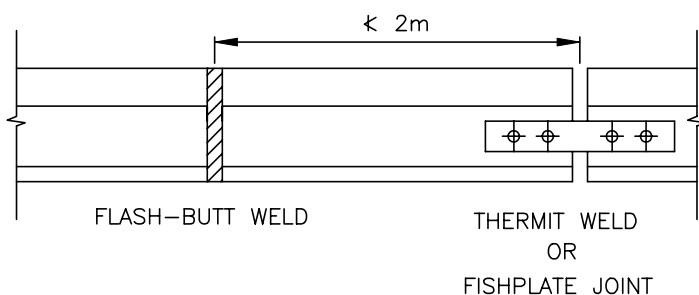

MINIMUM DISTANCE BETWEEN THERMIT WELD/FISHPLATE JOINT AND FLASH-BUTT WELD MUST BE AT LEAST 2m. ANY DEVIATION MUST BE APPROVED BY THE DEPOT ENGINEER PERSONALLY.

RAIL DRILLING FOR METRIC P AND M LUBRICATORS

POINTS BLADE LUBRICATORS

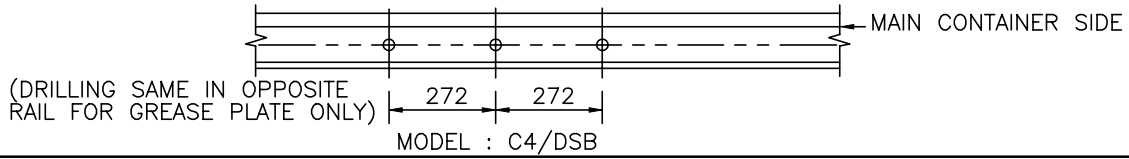

RUNNING RAIL LUBRICATORS

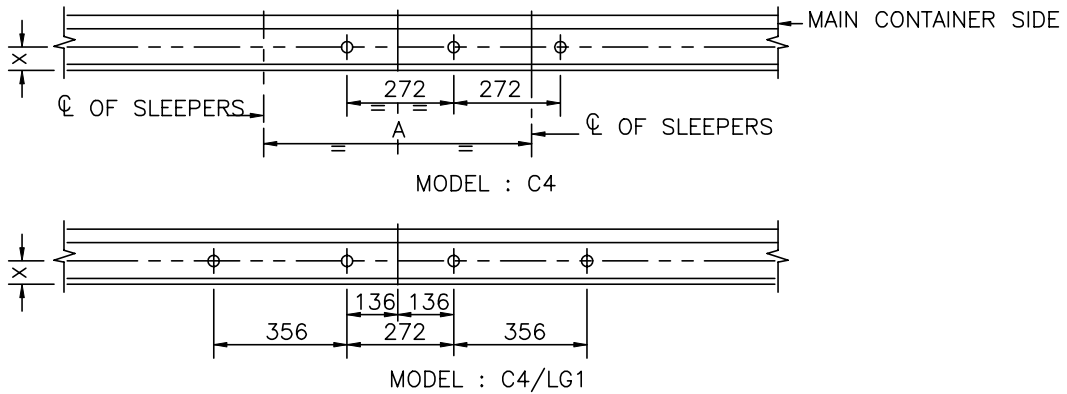

CHECK RAIL LUBRICATOR

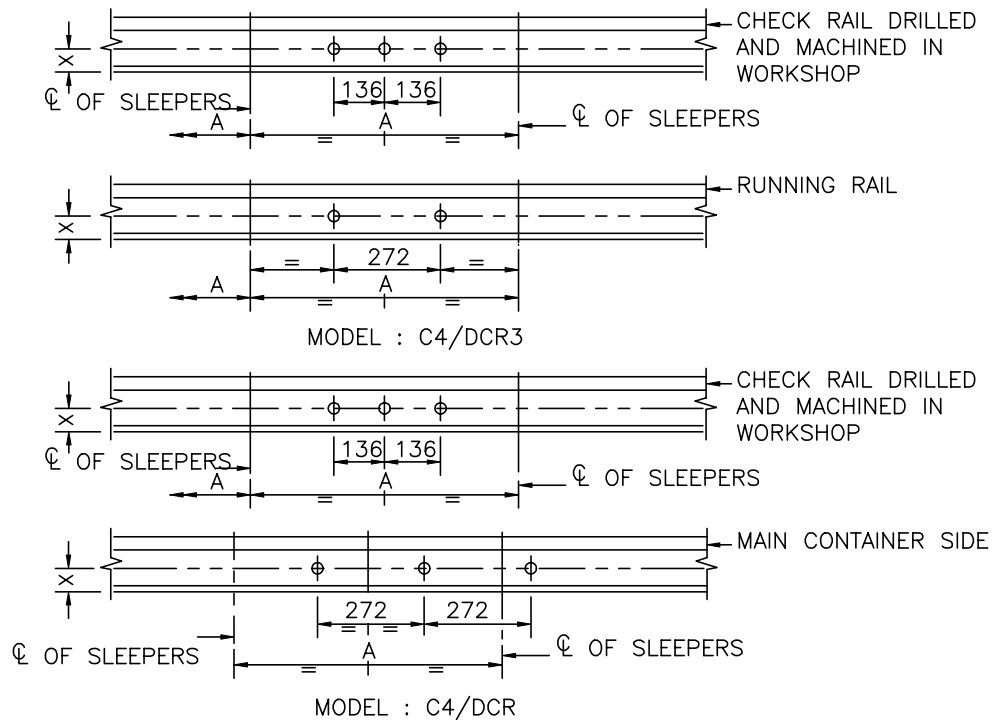

RAIL (kg)	DIMENSIONS	
	A	X
30	800	46
40	700	54
48	650/700	66
57	650/700	80

REMARKS:

1. ALL HOLES MUST BE DRILLED $\phi 22\text{mm}$.

JUMPERING WHEN TRACTION RAIL IS REPLACED

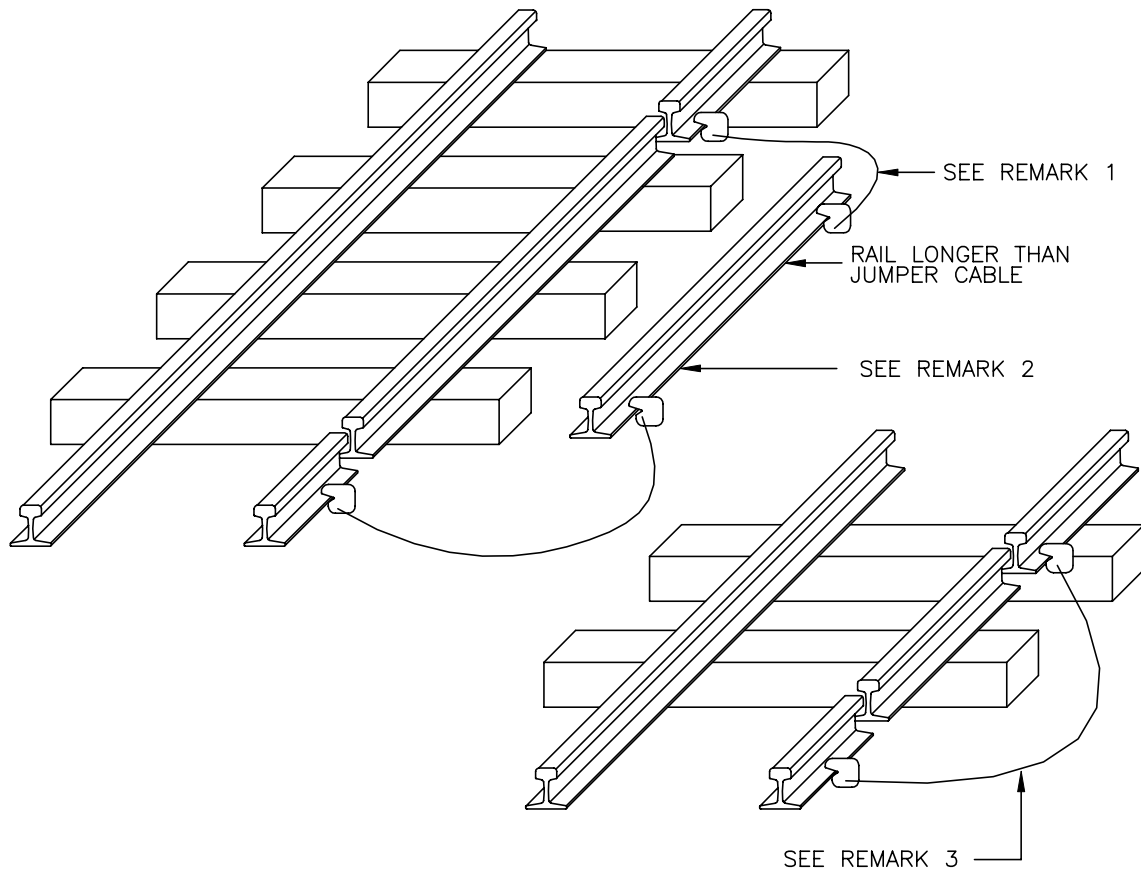

REMARKS:

1. SINGLE JUMPER CABLE FOR AC, DOUBLE JUMPER CABLE FOR DC, SEE SPECIFICATION CEE.0079 (LATEST REVISION).
2. USING TWO JUMPER CABLES, ATTACH ONE CLAMP OF EACH JUMPER TO EACH END OF THE NEW RAIL. ATTACH CLAMPS AT THE OTHER END OF EACH CABLE TO THE RAILS ON EITHER SIDE OF THE RAIL TO BE REMOVED. THE BASE OF THE JUMPER CLAMP AND THE RAIL MUST NEVER BE TOUCHED SIMULTANEOUSLY WHEN CONNECTING OR DISCONNECTING. THE CLAMP MUST BE PUSHED ONTO THE RAIL FLANGE BY HOLDING ONTO THE INSULATED CABLE. WHILE MAINTAINING THIS CONTACT, THE CLAMP MUST BE FIXED FIRMLY ONTO THE RAIL TO ENSURE CONTINUOUS ELECTRICAL CONTACT.
3. WHEN REPLACING SHORT LENGTHS OF RAIL OR FITTING FISH PLATES ACROSS A RAIL BREAK, THE JUMPER MAY BE CONNECTED DIRECTLY ACROSS THE GAP BEFORE FITTING OF THE FISH PLATES OR REMOVAL OF THE PORTION OF RAIL.
4. JUMPER CABLES MUST BE USED WHEN INSTALLING OR REMOVING JOGGLED FISH PLATES AT A BROKEN WELD, AS WELL AS DURING TRACK WELDING.
5. ON ALTERNATING-CURRENT SECTIONS BOTH RAILS OF OFF-TRACKING PLATFORMS FOR ON TRACK MACHINES MUST BE CONNECTED TO THE RUNNING RAIL BY MEANS OF JUMPER CABLES BEFORE THE OFF-TRACKING PLATFORMS ARE USED.

TYPICAL TURNOUTS :
SETS OF POINTS

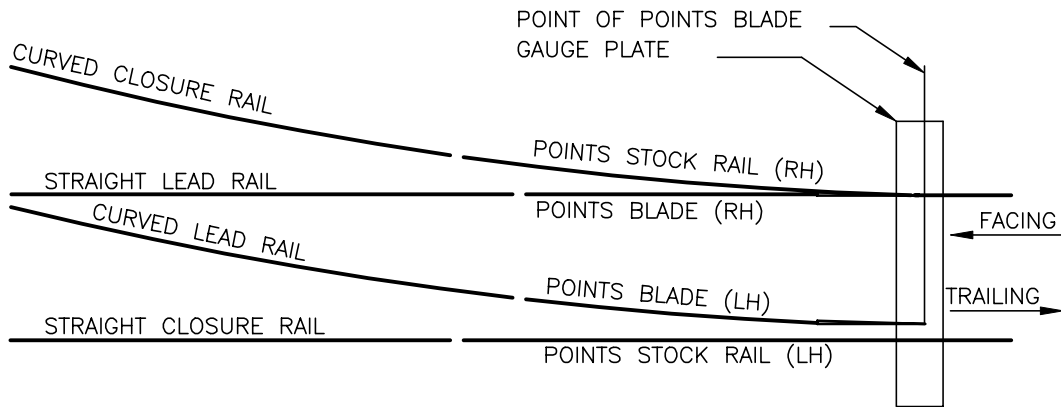

SEMI-CURVED HINGED POINTS BLADE

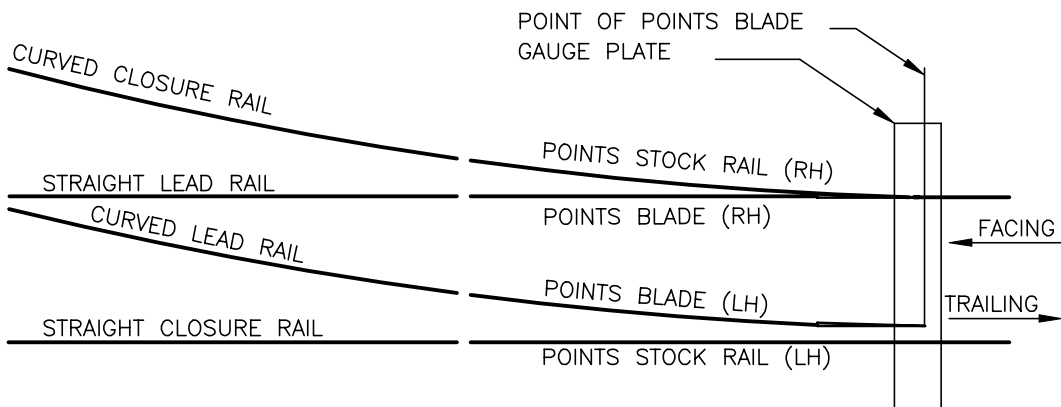

FULLY CURVED FLEXIBLE POINTS BLADE

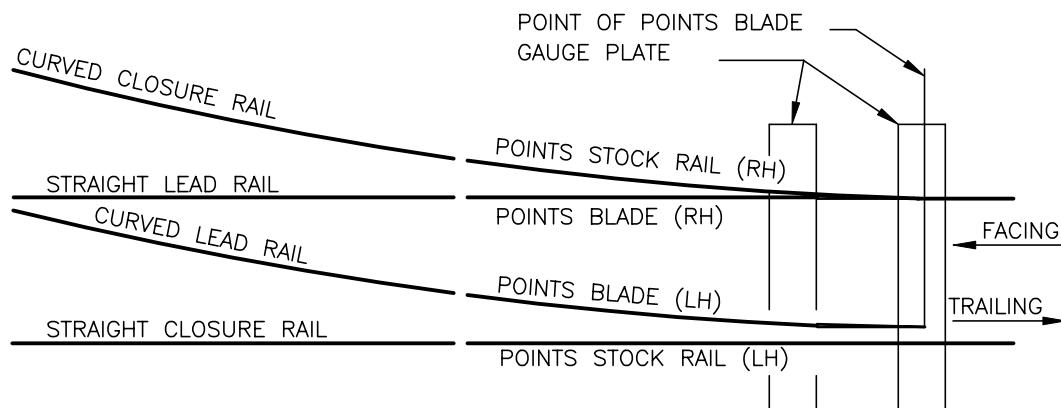

TRAILABLE SELF-NORMALISING POINTS BLADE

TYPICAL TURNOUTS :
CROSSINGS

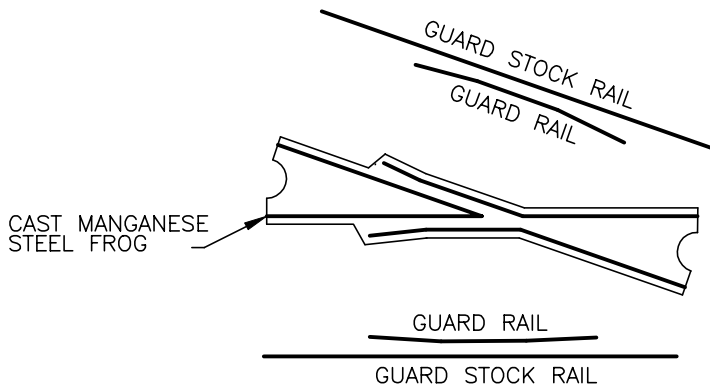

CROSSING WITH MANGANESE STEEL FROG

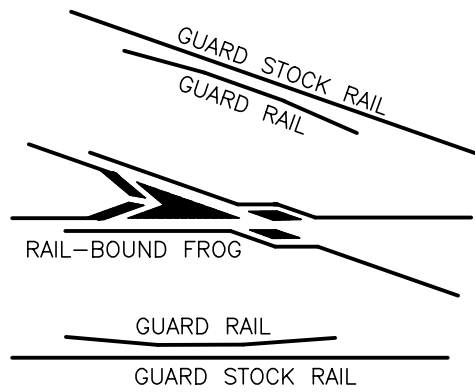

CROSSING WITH RAIL-BOUND FROG

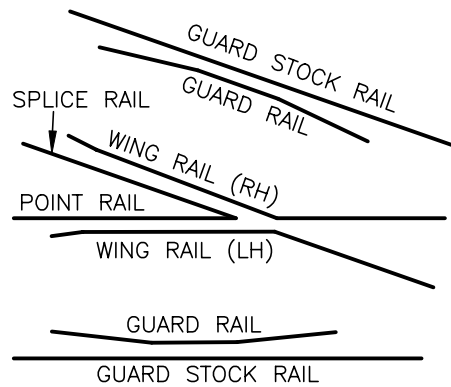

CROSSING WITH RAIL-MANUFACTURED FROG

TYPICAL TURNOUTS : CROSSINGS
WITH MOVEABLE VEE

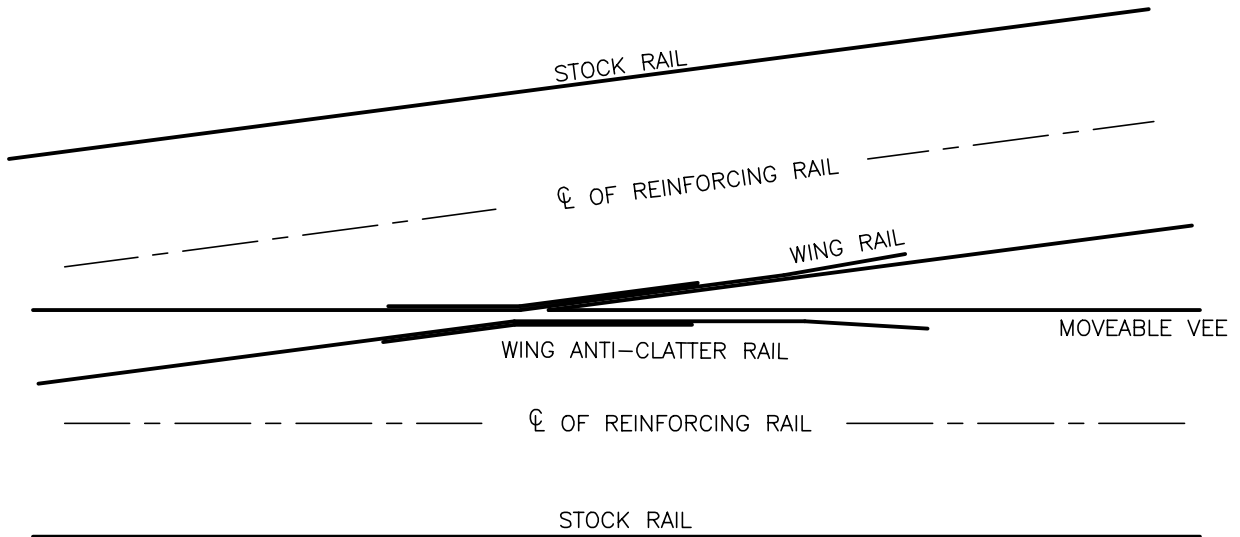

WITH HINGED JOINT

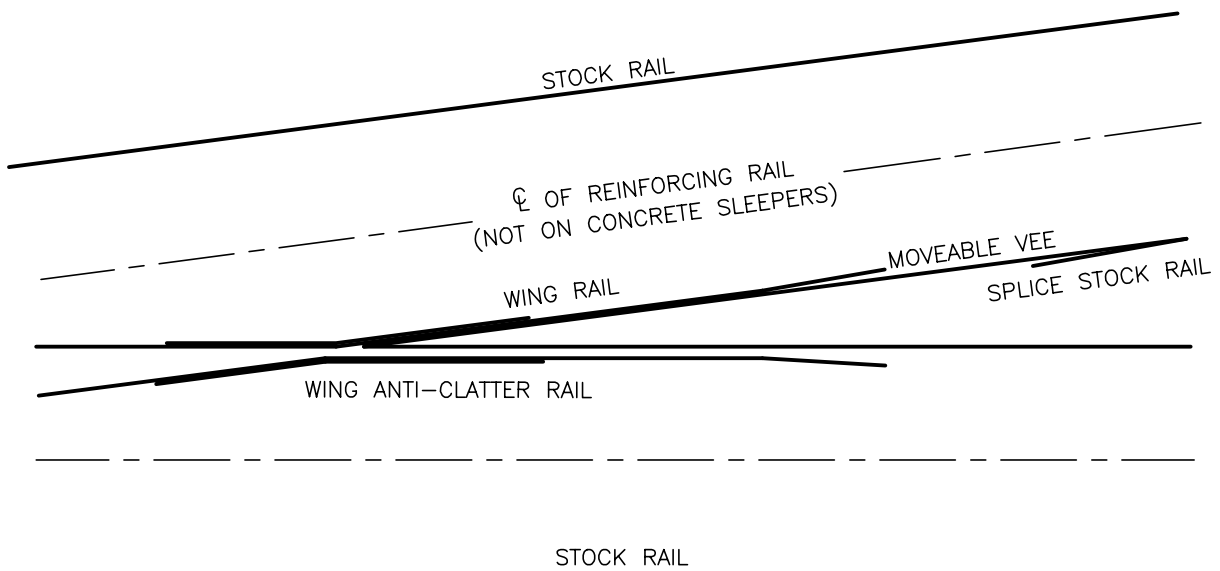

WITH BACK SLIDING JOINT

TURNOUTS WITH SEMI-CURVED
HINGED POINTS BLADES : LAYOUT

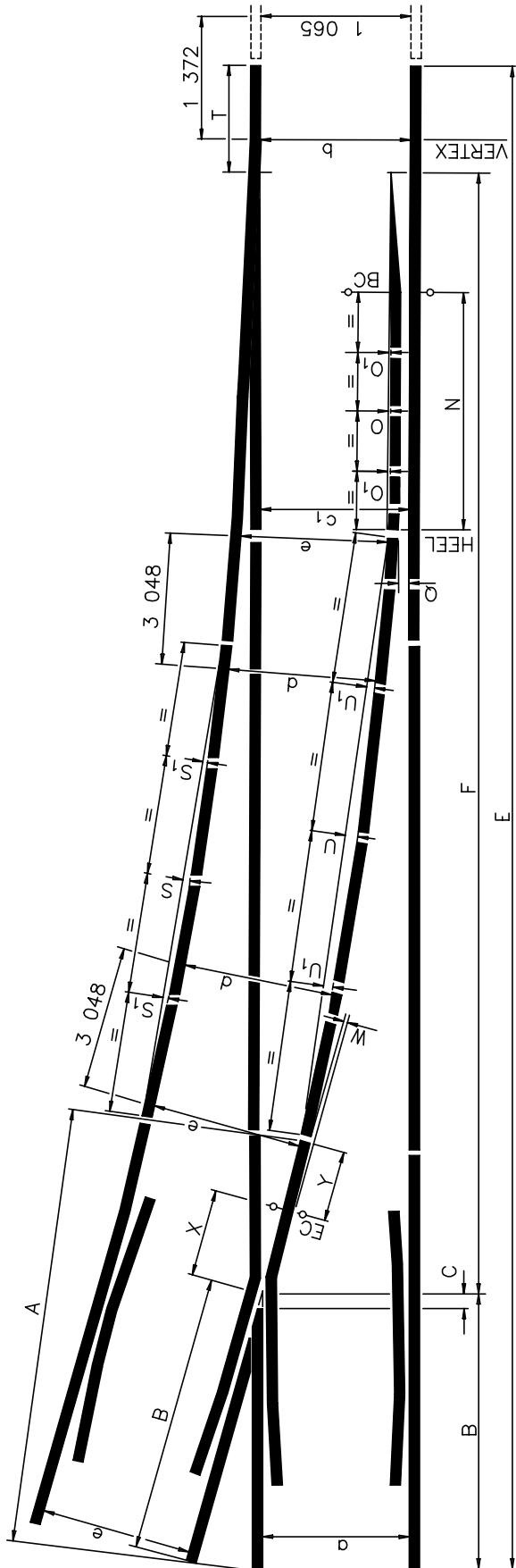

REMARKS:
 1. THE GAUGE OF THE STRAIGHT TRACK WILL BE NOMINAL THROUGHOUT, EXCEPT BETWEEN POINT AND HEEL OF POINTS BLADE.
 2. THIS DESIGN IS BASED ON ORIGINAL 3'-6" GAUGE.
 3. EQUAL-SPLIT SET.
 4. FOR OTHER DIMENSIONS SEE ANNEXURE 23 SHEETS 1 AND 4.

a	DESIGN	RAIL	ANGLE	GAUGE			
				b	c ₁	d	e
1 067	HINGED POINTS BLADE	48kg	1:9 AND 1:12	1 073	1 067	1 073	1 070
		48kg	1:8	1 080	1 067	1 080	1 070
		48kg	1:7	1 080	1 073	1 080	1 070
610	◆	48kg	1:6-◆	1 073	1 073	1 070	1 070
		30kg	1:9	616	613	616	613

TURNOUTS WITH FULLY CURVED
FLEXIBLE POINTS BLADES : LAYOUT

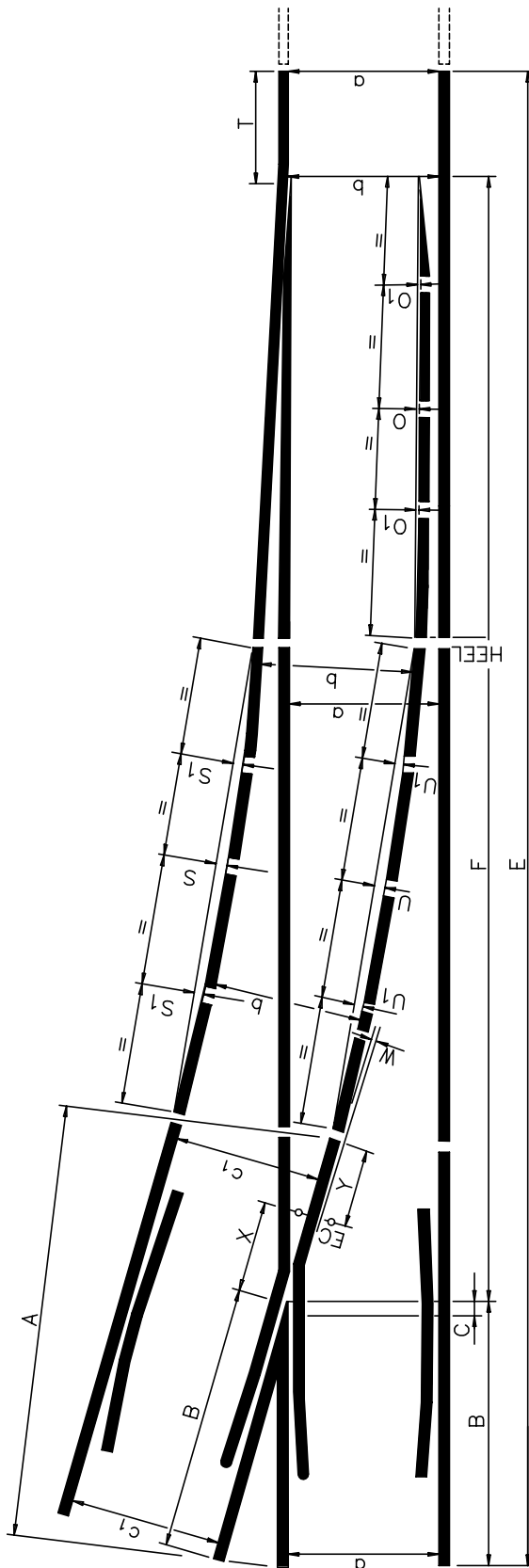

REMARKS:

1. THE GAUGE OF THE STRAIGHT TRACK WILL BE NOMINAL THROUGHOUT, EXCEPT BETWEEN POINT AND HEEL OF POINTS BLADE.
2. THIS DESIGN IS BASED ON ORIGINAL 3'-6" GAUGE.
3. FOR OTHER DIMENSIONS SEE ANNEXURE 23 SHEETS 1 AND 3.

a	DESIGN	RAIL	ANGLE	GAUGE		
				a	b	c ₁
1 067	FULLY CURVED FLEXIBLE POINTS BLADE	48/51kg	1:12	1 067	1 073	1 070
1 065		57/60kg	1:20	1 065	1 070	1 070

TURNOUTS WITH TRAILABLE SELF-NORMALISING POINTS BLADES : LAYOUT

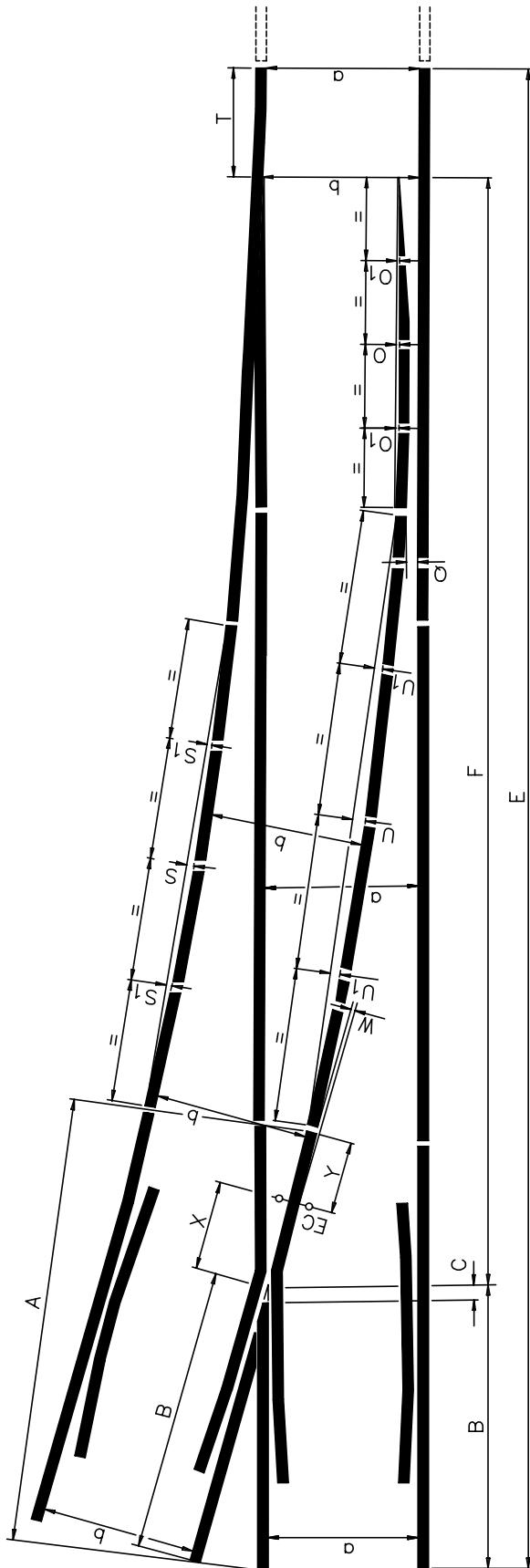

REMARKS:

1. THE GAUGE OF THE STRAIGHT TRACK WILL BE NOMINAL THROUGHOUT, EXCEPT BETWEEN POINT AND HEEL OF POINTS BLADE.
2. FOR OTHER DIMENSIONS SEE ANNEXURE 23 SHEET 2.

a	DESIGN	RAIL	ANGLE	GAUGE	
				a	b
1 065	TRAILABLE SELF-NORMALISING POINTS BLADE	48kg	1:12	1 065	1 070

TURNOUTS WITH FULLY CURVED FLEXIBLE
POINTS BLADES AND CAST MANGANESE
STEEL FROGS : LAYOUT

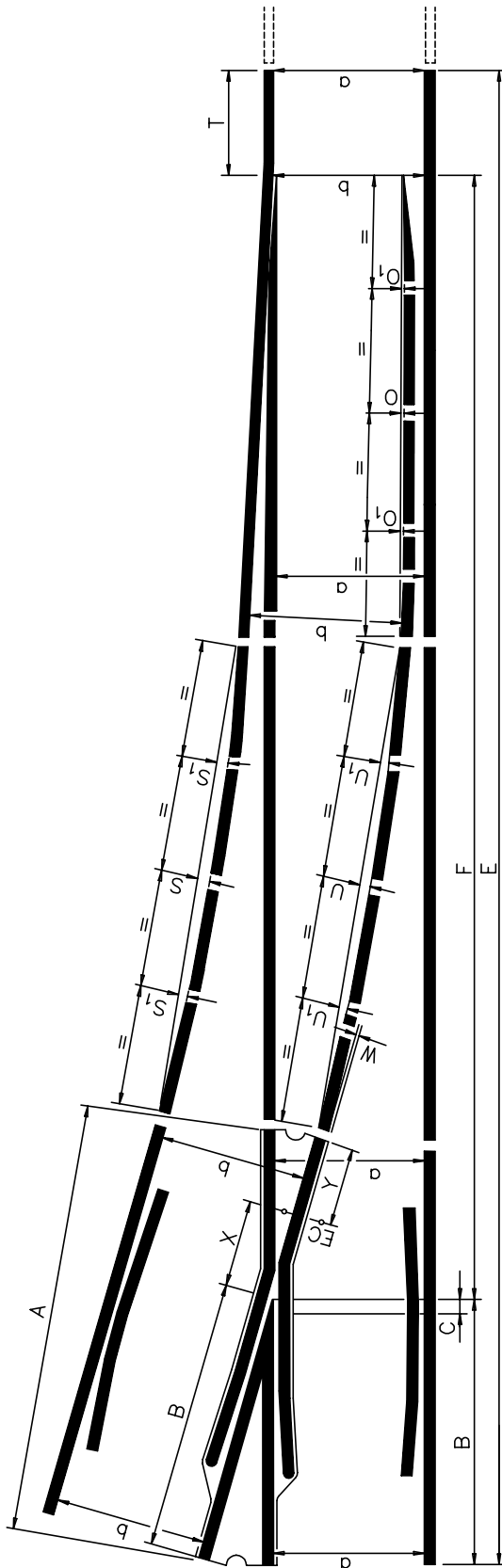

REMARKS:

1. THE GAUGE OF THE STRAIGHT TRACK WILL BE NOMINAL THROUGHOUT, EXCEPT BETWEEN POINT AND HEEL OF POINTS BLADE.
2. ϕ 1:6 EQUAL-SPLIT SET.
3. FOR OTHER DIMENSIONS SEE ANNEXURE 23 SHEETS 2 AND 3.

a	DESIGN	RAIL	ANGLE	GAUGE	
				a	b
1 065	FULLY CURVED FLEXIBLE POINTS BLADE AND CAST MANGANESE STEEL FROG	57/60kg	1:12	1 065	1 070
		48/51kg	1:12	1 065	1 070
		57/60kg	1:9	1 065	1 070
		57/60kg	1:8	1 065	1 070
		57/60kg	1:6 ϕ	1 070	1 070
		48/51kg	1:6 ϕ	1 070	1 070

TURNOUTS WITH FULLY CURVED FLEXIBLE
POINTS BLADES AND RAILBOUND
FROGS : LAYOUT

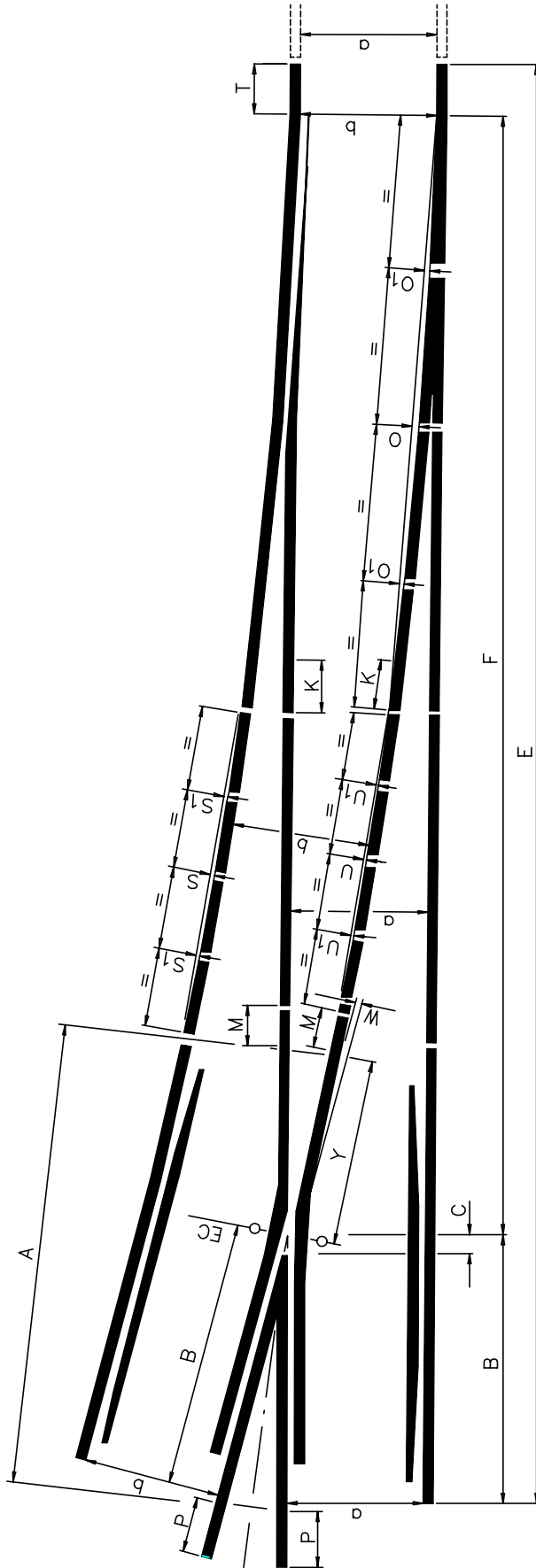

REMARKS:

1. THE GAUGE OF THE STRAIGHT TRACK WILL BE NOMINAL THROUGHOUT, EXCEPT BETWEEN POINT AND HEEL OF POINTS BLADE.
2. FOR OTHER DIMENSIONS SEE ANNEXURE 23 SHEETS 3 AND 7.

a	DESIGN	RAIL	ANGLE	GAUGE	
				a	b
1 065	FULLY CURVED FLEXIBLE POINTS BLADE	57/60kg	1:12	1 065	1 070
			1:9	1 065	1 070
		48/51kg	1:12	1 065	1 070

TURNOUTS WITH FULLY CURVED
FLEXIBLE COMPOSITE POINTS BLADES AND
RAILBOUND FROGS : LAYOUT

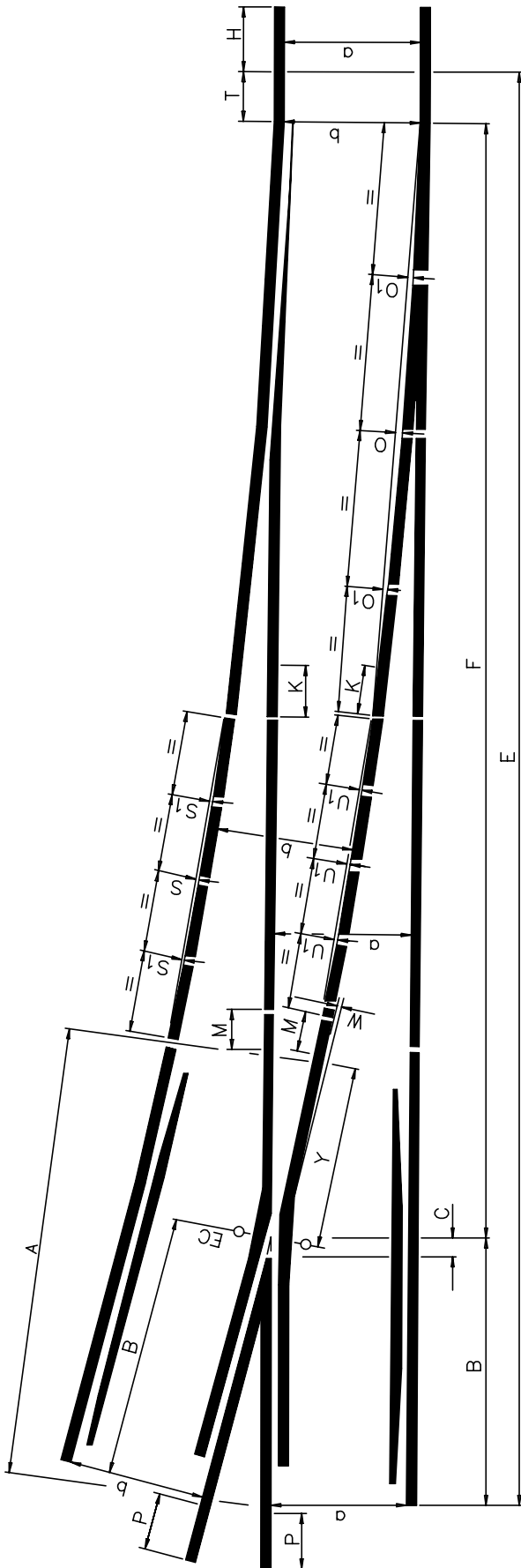

REMARKS:

1. THE GAUGE OF THE STRAIGHT TRACK WILL BE NOMINAL THROUGHOUT, EXCEPT BETWEEN POINT AND HEEL OF POINTS BLADE.
2. FOR OTHER DIMENSIONS SEE ANNEXURE 23 SHEETS 5 AND 8.

a	DESIGN	RAIL	ANGLE	GAUGE	
				a	b
1 065	FULLY CURVED FLEXIBLE COMPOSITE POINTS BLADE	S-60 SAR/ ZS-60 SAR	1:9 ϕ 1:12	1 065 1 065	1 070 1 065
		UIC-60/ Zu1-60	1:12	1 065	1 065

TURNOUTS WITH FULLY CURVED FLEXIBLE
COMPOSITE POINTS BLADES AND MOVABLE V-
PIECES WITH BACK SLIDING JOINTS : LAYOUT

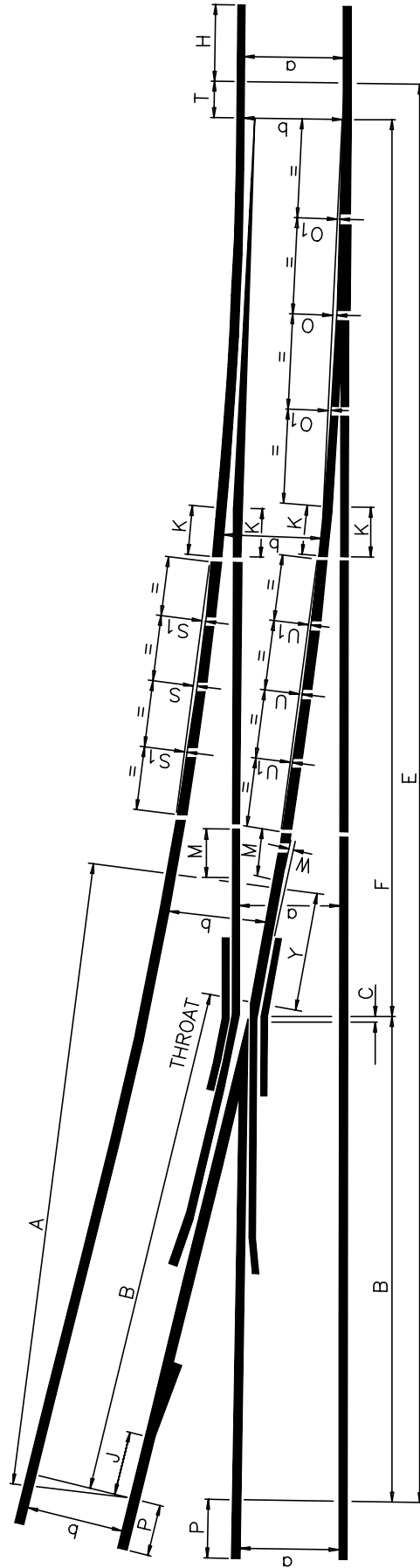

REMARKS:

1. FOR OTHER DIMENSIONS SEE ANNEXURE 23 SHEETS 5 AND 8.

a	DESIGN	RAIL	ANGLE	GAUGE	
				a	b
1 065	FULLY CURVED FLEXIBLE COMPOSITE POINTS BLADE	S-60 SAR/ ZS-60 SAR	1:20	1065	1065
		UIC-60/ Zu1-60	1:20	1065	1065

	TYPE OF POINTS BLADE	SEMI-CURVED HINGED POINTS BLADE						FULLY CURVED FLEXIBLE POINTS BLADE	
		1:6 9'-27'-44"	1:7 8'-7'-48"	1:8 7'-7'-30"	1:9 6'-20'-25"	1:9 6'-20'-25"	1:12 4'-45'-49"	1:12 4'-45'-49"	
A	LENGTH OF CROSSING	3 990	4 553	4 820	5 347	5 347	5 347	6 909	6 909
B	INTERSECTION OF GAUGES TO END	2 487	2 499	2 771	3 145	3 145	3 145	3 915	3 915
C	INTERSECTION OF GAUGES TO NOSE	76	89	102	114	114	114	152	152
	LENGTH OF POINTS BLADES	3 353	3 658	4 064	4 877	4 877	5 486	6 096	6 144
D	OVERALL LENGTH OF CROSS-OVER ROADS	-	40 758	45 392	51 518	51 518	53 042	66 814	66 859
E	OVERALL LENGTH	13 510	16 526	18 188	20 718	20 718	21 480	26 391	26 391
F	POINT OF POINTS BLADE TO INTERSECTION OF GAUGES	10 143	13 138	14 528	16 684	16 684	17 447	21 587	21 587
⊗	CLOSURE RAIL (STRAIGHT)	-	6 000	7 000	8 000	8 000	8 000	11 000	10 000
⊗	CLOSURE RAIL (CURVED)	4 000	6 000	7 000	8 000	8 000	8 000	11 000	10 000
⊗	LEAD RAIL (STRAIGHT)	-	8 000	9 000	10 000	10 000	10 000	13 000	10 000
⊗	LEAD RAIL (CURVED)	6 000	8 000	9 000	10 000	10 000	10 000	13 000	10 000
	RADIUS	137 160	103 734	137 973	173 431	173 431	171 602	300 228	304 800
W	CURVED WING RAIL	1,2	21	14,3	13,5	14,2	14,2	11	11
O	MIDDLE POINTS BLADE	4,3	1,7	4,8	5,6	6,8	6,8	5	34
O ₁	QUARTER	3,2	1,3	3,6	4	5,2	5,2	4	26
S	MIDDLE CLOSURE RAIL	13	35	35	40	42	42	44	37
S ₁	QUARTER	10	26	26	30	31	31	33	28
U	MIDDLE LEAD RAIL	25	67	64	67	70	70	65	37
U ₁	QUARTER	19	50	48	50	52	52	49	28
X	EC TO INTERSECTION OF GAUGES	945	0	74	40	0	0	425	425
Y	EC TO END OF WING RAIL	572	2 065	1 984	2 170	2 170	2 210	2 575	2 575
N	BC TO HEEL	2 165	1 202	2 289	2 746	2 746	3 019	3 432	-
Q	HEEL OPENING	132	85	88	90	92	92	89	-
	VERTEX TO POINT OF POINTS BLADE	132	165	197	238	238	275	297	-
T	END OF STOCK RAIL TO POINT OF POINTS BLADE	889	889	889	889	889	889	889	889
	DRAWING NUMBERS	7 051	7 015 SHEET 4	7 015 SHEET 3	7 015 SHEET 2	7 015 SHEET 2-003	7 015 SHEET 1	7 047	7 047

REMARKS: 1. 1:6 IS AN EQUAL-SPLIT SET.
2. ⊗ CUT TO SIZE FROM LENGTHS SUPPLIED.
3. THESE DESIGNS ARE BASED ON ORIGINAL 3'-6" GAUGE.
4. FOR LAYOUTS SEE ANNEXURE 22 SHEETS 1 AND 2.
5. OVERALL LENGTH OF CROSS-OVER ROADS IS BASED ON ORIGINAL 13'-0" TRACK CENTRES.

TYPE OF POINTS BLADE		FULLY-CURVED FLEXIBLE POINTS BLADE		SELF NORMALISING POINTS BLADE
ANGLE OF TURNOUT		1:6 9'-27'-44"	1:12 4'-45'-49"	1:12 4'-45'-49"
A	LENGTH OF CROSSING	4 400	6 909	6 909
B	INTERSECTION OF GAUGES TO END	2 531	3 915	3 915
C	INTERSECTION OF GAUGES TO NOSE	85	156	152
	LENGTH OF POINTS BLADES	10 210	9 000	6 000
D	OVERALL LENGTH OF CROSS-OVER ROADS	-	67 288	67 288
E	OVERALL LENGTH	15 500	26 391	26 390
F	POINT OF POINTS BLADE TO INTERSECTION OF GAUGES	12 088	21 586	21 586
⊗	CLOSURE RAIL (STRAIGHT)	-	10 000	11 000
⊗	CLOSURE RAIL (CURVED)	-	10 000	11 000
⊗	LEAD RAIL (STRAIGHT)	-	10 000	13 000
⊗	LEAD RAIL (CURVED)	-	10 000	13 000
	RADIUS	191 231	320 845	321 508
W	CURVED WING RAIL	-	11	11
O	MIDDLE POINTS BLADE	68	32	14
O ₁	QUARTER	51	24	10,5
S	MIDDLE CLOSURE RAIL	-	36	44,5
S ₁	QUARTER	-	27	33,4
U	MIDDLE LEAD RAIL	-	36	62
U ₁	QUARTER	-	27	46,5
X	EC TO INTERSECTION OF GAUGES	-1 216	425	425
Y	EC TO END OF WING RAIL	3 100	2 575	2 575
Q	HEEL OPENING	-	-	77
T	END OF STOCK RAIL TO POINT OF POINTS BLADE	890	890	890
	DRAWING NUMBERS TYPE E	7 075	7 084	7 085

REMARKS: 1. 1:6 IS AN EQUAL-SPLIT SET.
2. ⊗ CUT TO SIZE FROM LENGTHS SUPPLIED.
3. FOR LAYOUTS SEE ANNEXURE 22 SHEETS 3 AND 4.
4. OVERALL LENGTH OF CROSS-OVER ROADS IS BASED ON 4 000mm TRACK CENTRES.

TYPE OF POINTS BLADE		FULLY-CURVED FLEXIBLE POINTS BLADE					
ANGLE OF TURNOUT		1:6 9'-27'-44"	1:8 7'-7'-30"	1:9 6'-20'-25"	1:12 4'-45'-49"	1:20 2'-51'-45"	
A	LENGTH OF CROSSING	4 400	4 820	5 891	7 533	11 574	
B	INTERSECTION OF GAUGES TO END	2 530	2 771	3 725	4 540	-	
C	INTERSECTION OF GAUGES TO NOSE	85	120	117	156	-	
	LENGTH OF POINTS BLADES	10 214	7 075	9 000	9 000	12 000	
D	OVERALL LENGTH OF CROSS-OVER ROADS	-	45 688	51 874	67 288	108 194	
E	OVERALL LENGTH	15 500	18 188	21 299	27 016	42 251	
F	POINT OF SWITCH BLADE TO INTERSECTION OF GAUGES	12 088	14 527	16 684	21 586	34 703	
⊗	CLOSURE RAIL (STRAIGHT)	-	6 000	6 000	10 000	18 000	
⊗	CLOSURE RAIL (CURVED)	-	6 000	6 000	10 000	18 000	
⊗	LEAD RAIL (STRAIGHT)	-	6 000	6 000	10 000	18 000	
⊗	LEAD RAIL (CURVED)	-	6 000	6 000	10 000	18 000	
	RADIUS	191 231	142 958	178 938	320 845	904 553	
W	CURVED WINGS RAIL	-	14,6	13,2	14	6,8	
O	POINTS BLADE	68,2	43,8	56,4	31,6	19,9	
O ₁	QUARTER	51,2	32,8	42,3	23,7	14,9	
S	CLOSURE RAIL	-	26	21,4	36,1	44,8	
S ₁	QUARTER	-	19,5	16	27,1	33,6	
U	LEAD RAIL	-	26	21,2	35,8	44,8	
U ₁	QUARTER	-	19,5	15,9	26,9	33,6	
X	EC TO INTERSECTION OF GAUGE	-1 216	0	0	0	-	
Y	EC TO END OF WING RAIL	3 099	2 058	2 175	3 000	3 514	
T	END OF STOCK RAIL TO POINT OF POINTS BLADE	890	890	890	890	760	
H		-	-	-	-	-	
K		-	-	-	-	-	
M		-	-	650	600	-	
P		-	-	650	650	-	
	DRAWING NUMBERS	7 078	7 076	7 089	7 088	7 094	

REMARKS: 1. 1:6 IS AN EQUAL-SPLIT SET.

2. FOR LAYOUTS SEE ANNEXURE 22 SHEETS 2, 4 AND 5.

3. ⊗ CUT TO SIZE FROM LENGTHS SUPPLIED.

4. INFORMATION FOR 1:9 AND 1:12 IS BASED ON THE USE OF RAILBOUND FROGS.

5. LENGTH OF FROG FOR INITIAL INSTALLATION.

6. TOTAL LENGTH OF CROSS-OVER ROADS BASED ON 4 000 mm TRACK CENTRES.

	ANGLE OF TURNOUT	1:9 6'-20'-25"	
A	LENGTH OF CROSSING	4 572	
B	INTERSECTION OF GAUGES TO END	2 515	
C	INTERSECTION OF GAUGES TO NOSE	114	
	LENGTH OF POINTS BLADE	3 353	
D	OVERALL LENGTH OF CROSS-OVER ROADS	38 760	
E	OVERALL LENGTH	12 309	
F	POINT OF POINTS BLADE TO INTERSECTION OF GAUGES	8 931	
	CLOSURE RAIL (STRAIGHT)	-	
	CLOSURE RAIL (CURVED)	-	
	LEAD RAIL (STRAIGHT)	3 508	
	LEAD RAIL (CURVED)	3 534	
	RADIUS	72 314	
W	CURVED WING RAIL	7,7	
O	POINTS BLADE	MIDDLE	1,8
O ₁		QUARTER	1,3
S	CLOSURE RAIL	MIDDLE	-
S ₁		QUARTER	-
U	LEAD RAIL	MIDDLE	21,6
U ₁		QUARTER	16
X	EC TO INTERSECTION OF GAUGES	1 003	
Y	EC TO END OF WING RAIL	1 060	
N	BC TO HEEL	1 027	
Q	HEEL OPENING	79	
	VERTEX TO POINT OF POINTS BLADE	170	
T	END OF STOCK RAIL TO POINT OF POINTS BLADE	864	
	DRAWING NUMBER	566 SHEET 5	
	TYPE	E	

REMARKS: 1. THIS DESIGN IS BASED ON ORIGINAL 2' - 0" GAUGE.
2. FOR LAYOUT SEE ANNEXURE 22 SHEET 1.

TYPE OF POINTS BLADE		FULLY-CURVED COMPOSITE FLEXIBLE POINTS BLADE		
ANGLE OF TURNOUT		1:9 6'-20'-25"	1:12 4'-45'-49"	1:20 2'-51'-45"
A	LENGTH OF CROSSING	5 950	6 945	15 813
B	INTERSECTION OF GAUGES TO END (THROAT TO END 1:20)	3 725	3 915	9 888
C	INTERSECTION OF GAUGES TO NOSE	117	156	-
L	END OF VEE TO THROAT	-	-	150
	LENGTH OF POINTS BLADES	9 000	10 150	15 700
D	OVERALL LENGTH OF CROSS-OVER ROADS	51 874	67 350	108 300
E	OVERALL LENGTH	21 299	26 391	44 034
F	POINT OF SWITCH BLADE TO INTERSECTION OF GAUGES (THROAT 1:20)	16 684	21 587	33 386
⊗	CLOSURE RAIL (STRAIGHT)	6 000	9 000	12 000
⊗	CLOSURE RAIL (CURVED)	6 000	9 000	12 000
⊗	LEAD RAIL (STRAIGHT)	6 000	9 000	12 000
⊗	LEAD RAIL (CURVED)	6 000	9 000	12 000
	RADIUS	178 938	320 665	904 553
W	CURVE WING RAIL	22,3	39	39,4
O	POINTS BLADE	67,1	47,2	37,6
O ₁	QUARTER	50,3	35,4	28,2
S	MIDDLE	25,2	31,6	19,9
S ₁	QUARTER	18,9	23,7	14,9
U	MIDDLE	25,2	31,6	19,9
U ₁	QUARTER	18,9	23,7	14,9
Y	EC TO END OF WING RAIL	2 225	3 000	-
J	END OF VEE TO BACK END OF SPLICE RAIL	-	-	855
T	END OF STOCK RAIL TO POINT OF POINTS BLADE	890	890	760
H		710	610	740
K		800	850	800
M		600	2 000	1 200
P		650	1 500	650
	DRAWING NUMBER	7 103	7 102	7 101
	TYPE E			

REMARKS: 1. ⊗ CUT TO SIZE FROM LENGTHS SUPPLIED. 4. OFFSETS ARE BASED ON SUPPLIED LENGTHS.

2. ALL DIMENSIONS QUOTED ARE FOR INITIAL INSTALLATION.

3. FOR LAYOUTS SEE ANNEXURE 22 SHEETS 6 AND 7.

TYPE OF POINTS BLADE		FULLY-CURVED FLEXIBLE COMPOSITE POINTS BLADE	
	ANGLE OF TURNOUT	1:9 6'-20'-25"	1:12 4'-45'-49"
A	LENGTH OF CROSSING	VARIABLE	
B	INTERSECTION OF GAUGES TO END	VARIABLE	
C	INTERSECTION OF GAUGES TO NOSE	117	156
	LENGTH OF POINTS BLADES	11 300	13 650
D	OVERALL LENGTH OF CROSS-OVER ROADS	-	-
E	OVERALL LENGTH	22 650	29 408
F	POINT OF POINTS BLADE TO INTERSECTION OF GAUGES	19 415	23 929
	CLOSURE RAIL (STRAIGHT)	-	-
	CLOSURE RAIL (CURVED)	-	-
	LEAD RAIL (STRAIGHT)	-	-
	LEAD RAIL (CURVED)	-	-
	RADIUS	190 000	300 000
W	CURVED WING RAIL	-	-
O	POINTS BLADE	84	77,6
O ₁		63	58,2
S	CLOSURE RAIL	-	-
S ₁		-	-
U	LEAD RAIL	-	-
U ₁		-	-
X	EC TO INTERSECTION OF GAUGES	929	324
Y	EC TO END OF WING RAIL	-	-
T	END OF STOCK RAIL TO POINT OF POINTS BLADE	700	1 350
	DRAWING NUMBERS	700-E-739	700-E-736

	TYPE OF POINTS BLADE	FULLY-CURVED FLEXIBLE POINTS BLADE
	ANGLE OF TURNOUT	1:12 4'-45'-49"
A	LENGTH OF CROSSING	7 227
B	INTERSECTION OF GAUGES TO END	4 275
C	INTERSECTION OF GAUGES TO NOSE	156
	LENGTH OF POINTS BLADES	9 000
D	OVERALL LENGTH OF CROSS-OVER ROADS	67 288
E	OVERALL LENGTH	26 751
F	POINT OF POINTS BLADE TO INTERSECTION OF GAUGES	21 586
⊗	CLOSURE RAIL (STRAIGHT)	10 000
⊗	CLOSURE RAIL (CURVED)	10 000
⊗	LEAD RAIL (STRAIGHT)	10 000
⊗	LEAD RAIL (CURVED)	10 000
	RADIUS	320 845
W	CURVED WING RAIL	27
O	POINTS BLADE	MIDDLE
O ₁		QUARTER
S	CLOSURE RAIL	MIDDLE
S ₁		QUARTER
U	LEAD RAIL	MIDDLE
U ₁		QUARTER
Y	EC TO END OF WING RAIL	2 960
T	END OF STOCK RAIL TO POINT OF POINTS BLADE	890
H	INDICATES POSITIONS AND AREAS WHERE THERMIT WELD JOINTS ARE LOCATED	-
K		-
M		1 200
P		800
		DRAWING NUMBER TYPE E

REMARKS: 1. ⊗ CUT TO SIZE FROM LENGTHS SUPPLIED.
2. ALL DIMENSIONS QUOTED ARE FOR INITIAL INSTALLATION.
3. FOR LAYOUT SEE ANNEXURE 22 SHEET 5.
4. DEVIATIONS FROM STANDARD DUE TO THE PROVISION FOR THERMIT WELDS.
5. OFFSETS ARE CALCULATED ON SUPPLIED LENGTHS.

TURNOUTS UIC-60 : 1 065mm
TRACK GAUGE : CONCRETE SLEEPERS :
DIMENSIONS

	TYPE OF POINTS BLADE	FULLY-CURVED FLEXIBLE COMPOSITE POINTS BLADE
	ANGLE OF TURNOUT	1:12 4'-45" - 49"
A	LENGTH OF CROSSING	6 945
B	INTERSECTION OF GAUGES TO END (THROAT TO END 1:20)	3 915
C	INTERSECTION OF GAUGES TO NOSE	156
L	POINT OF VEE TO THROAT	-
	LENGTH OF POINTS BLADES	10 150
D	OVERALL LENGTH OF CROSS-OVER ROADS	67 350
E	OVERALL LENGTH	26 391
F	POINT OF POINTS BLADE TO INTERSECTION OF GAUGES (THROAT 1:20)	21 587
⊗	CLOSURE RAIL (STRAIGHT)	9 000
⊗	CLOSURE RAIL (CURVED)	9 000
⊗	LEAD RAIL (STRAIGHT)	9 000
⊗	LEAD RAIL (CURVED)	9 000
	RADIUS	320 665
W	CURVED WING RAIL	39
O	POINTS BLADE	47,2
O ₁	QUARTER	35,4
S	MIDDLE	31,6
S ₁	QUARTER	23,7
U	MIDDLE	31,6
U ₁	QUARTER	23,7
Y	EC TO END OF WING RAIL	3 000
J	END OF VEE TO BACK END OF SPLICE RAIL	-
T	END OF STOCK RAIL TO POINT OF POINTS BLADE	890
H		610
K		850
M		2 000
P		1 500
	DRAWING NUMBERS	7 131
	TYPE E	7 130

REMARKS: 1. ⊗ CUT TO SIZE FROM LENGTHS SUPPLIED.
2. ALL DIMENSIONS QUOTED ARE FOR INITIAL INSTALLATION.
3. FOR LAYOUT SEE ANNEXURE 22 SHEETS 6 AND 7.
4. OFFSETS ARE CALCULATED ON SUPPLIED LENGTHS.

RADII OF TURNOUTS FROM
CURVED TRACK

TRACK GAUGE (mm)	1 065										610	
	CONTRARY FLEXURE (■)					SIMILAR FLEXURE (●)					■	●
	1:7	1:8	1:9	1:12	1:20	1:7	1:8	1:9	1:12	1:20	1:9	1:9
60	—	—	—	—	—	—	—	—	—	—	—	—
75	—	—	—	—	—	—	—	—	—	—	800	—
100	—	—	—	—	—	—	—	—	—	—	257	—
110	907	—	—	—	—	—	—	—	—	—	208	—
120	780	—	—	—	—	—	—	—	—	—	180	—
140	404	—	—	—	—	—	—	—	96	—	148	—
160	297	915	—	—	—	—	—	—	105	—	131	50
180	246	558	—	—	—	—	—	—	113	—	120	51
200	217	426	1 255	—	—	—	—	93	121	—	113	53
250	178	299	551	—	—	—	—	102	137	—	101	56
300	159	249	406	—	—	—	94	110	151	—	95	58
350	148	223	340	2 227	—	—	98	116	163	—	91	60
400	141	207	304	1 251	—	—	102	121	173	—	88	61
450	135	195	280	928	—	—	105	125	181	—	86	62
500	131	187	264	770	—	—	107	129	189	—	84	63
550	128	181	251	675	—	—	109	132	196	—	83	64
600	126	176	242	612	—	—	111	134	202	—	82	64
650	124	172	235	568	—	90	113	137	207	—	81	65
700	122	169	229	535	—	91	114	139	212	—	80	65
750	121	166	224	509	—	91	116	141	216	—	80	66
800	120	164	220	488	—	92	117	142	220	—	79	66
900	118	160	214	457	—	93	119	145	227	—	78	67
1 000	116	158	209	435	—	94	120	147	233	—	78	67
1 200	114	154	202	406	—	96	123	151	242	—	77	68
1 400	112	151	197	387	—	97	124	154	249	—	76	68
1 600	111	149	194	374	—	98	126	156	255	—	75	69
1 800	110	147	191	365	—	98	127	158	260	—	75	69
2 000	110	146	189	357	—	99	128	159	263	—	75	69
3 000	108	143	183	337	—	101	130	164	276	—	74	70
STRAIGHT	104	136	173	303	—	104	136	173	303	—	72	72

DIAMOND CROSSINGS 48kg 1:4½, 1:6,
1:7 AND 1:8 : 1 067mm TRACK GAUGE :
LAYOUT AND DIMENSIONS

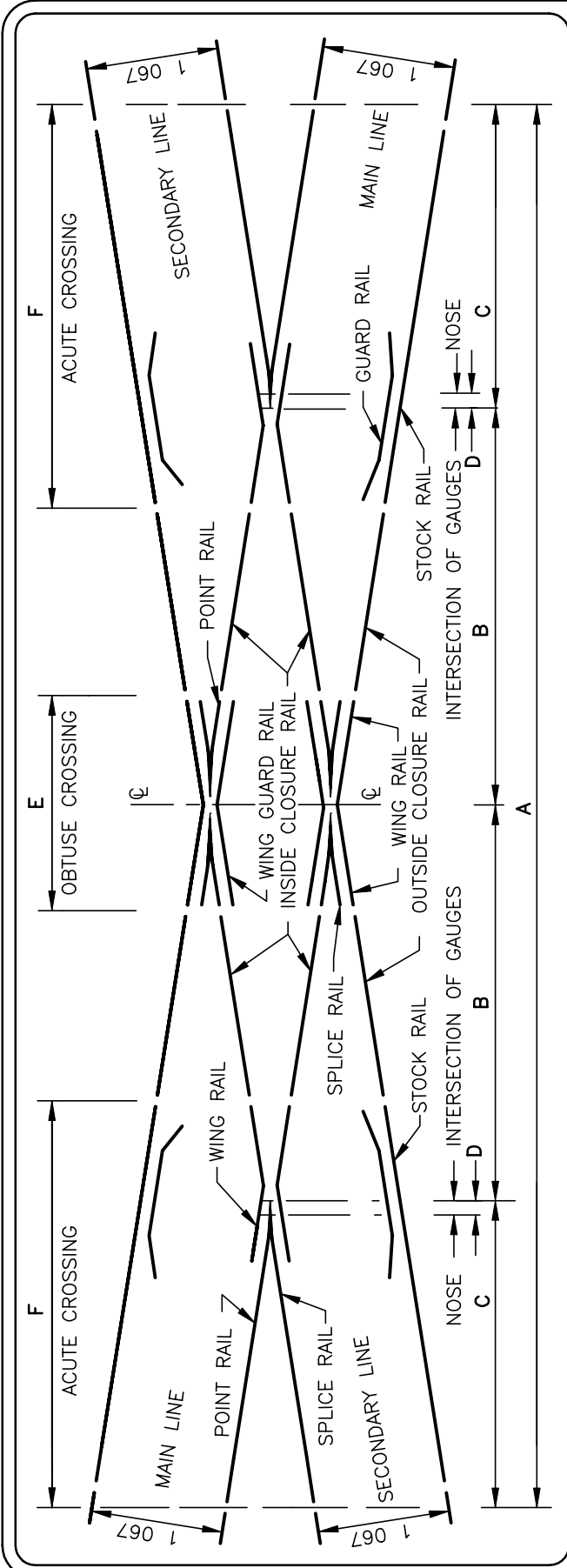

ANGLE OF DIAMOND CROSSING		1:4½	1:6	1:7	1:8
		12'-40'-50"	9'-31'-38"	8'-7'-48"	7'-7'-30"
A	OVERALL LENGTH	13 920	19 608	20 012	22 700
B	INTERSECTION OF GAUGES TO: CENTRE LINE END NOSE	4 831	6 423	7 525	8 585
C		2 129	3 381	2 481	2 765
D		57	76	89	102
E	LENGTH OF OBTUSE CROSSING	4 261	7 398	4 108	4 705
F	LENGTH OF ACUTE CROSSING	4 823	6 099	4 416	4 566
	DRAWING NUMBERS	7 040	7 041	688	7 050
		TYPE E			

REMARKS:
1. WHEN ORDERING SINGLE ITEMS FOR REPLACEMENT, IT IS ESSENTIAL TO QUOTE STORES ITEM NUMBERS.
REFER LIST OF STANDARD PERMANENT WAY MATERIAL, SECTION 53.
2. THIS DESIGN IS BASED ON ORIGINAL 3'-6" GAUGE.

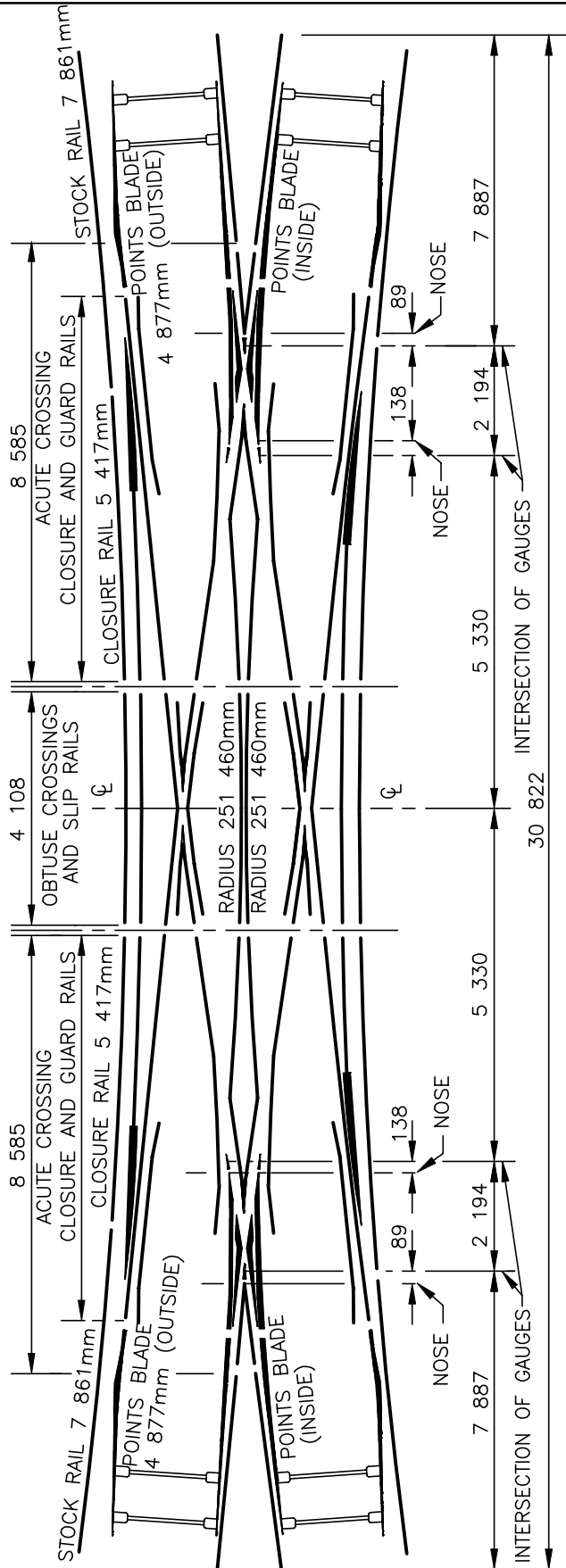

LOCATION	GAUGE
1 524mm BEFORE POINT OF POINTS BLADE	1 067
POINT OF POINTS BLADE	1 073
HEEL OF POINTS BLADE	1 067
ALL OTHER LOCATIONS	1 070

REMARKS:

1. WHEN ORDERING SINGLE ITEMS FOR REPLACEMENT, IT IS ESSENTIAL TO QUOTE STORES ITEM NUMBERS.
REFER LIST OF STANDARD PERMANENT WAY MATERIALS, SECTION 53.
2. THIS DESIGN IS BASED ON ORIGINAL 3'-6" GAUGE.

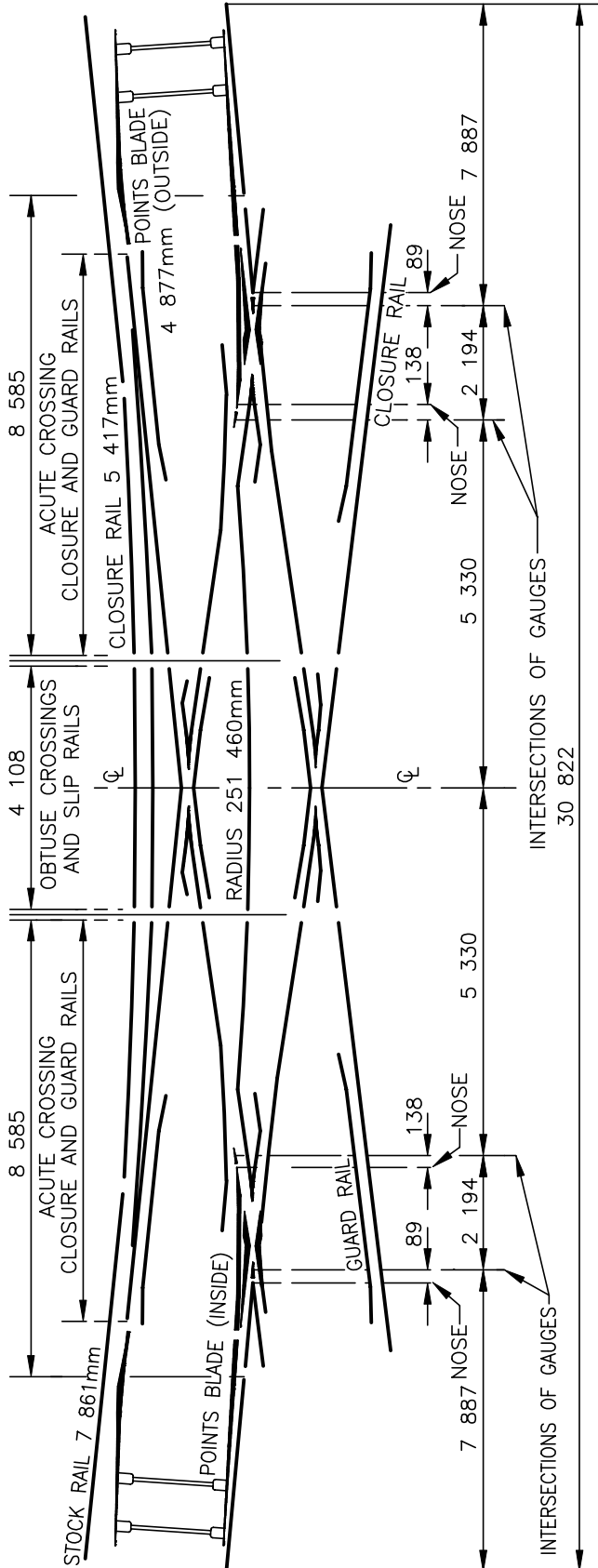

LOCATION	GAUGE
1 524mm BEFORE POINT OF POINTS BLADE	1 067
POINT OF POINTS BLADE	1 073
HEEL OF POINTS BLADE	1 067
ALL OTHER LOCATIONS	1 070

REMARKS:

1. WHEN ORDERING SINGLE ITEMS FOR REPLACEMENT, IT IS ESSENTIAL TO QUOTE STORES ITEM NUMBERS. REFER LIST OF STANDARD PERMANENT WAY MATERIALS, SECTION 53.
2. THIS DESIGN IS BASED ON ORIGINAL 3'-6" GAUGE.

BLOCK JOINTS : TURNOUTS AND
DIAMOND CROSSINGS

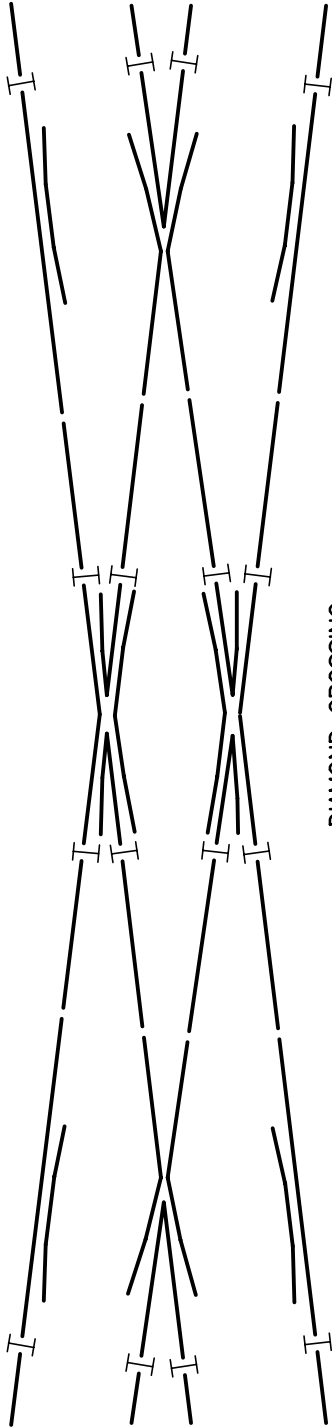

DIAMOND CROSSING

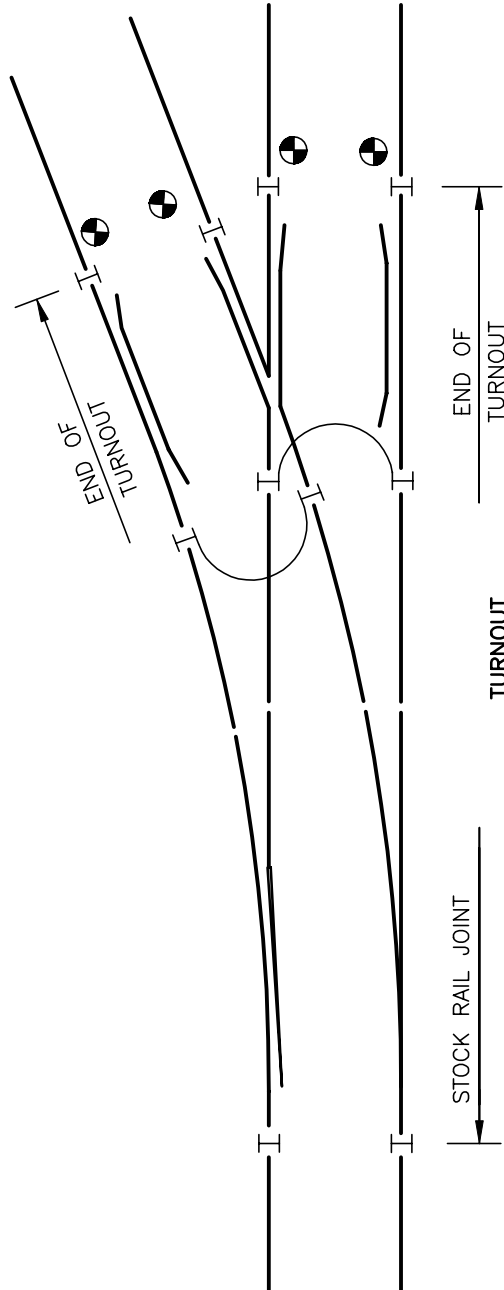

REMARKS:

1. POSSIBLE BLOCK JOINT POSITIONS IN OR OUTSIDE TURNOUTS.
2. WHERE TURNOUTS ARE PART OF A GATHERING ROAD, BLOCK JOINTS ARE ALSO POSSIBLE.
3. WHEN BLOCK JOINTS ON SETS HAVE TO BE REPLACED CONSIDERATION MUST BE GIVEN TO MOVING THE BLOCK JOINTS TO THE TURNOUT PORTION OF THE SET.

BLOCK JOINTS : SINGLE AND
DOUBLE SLIPS

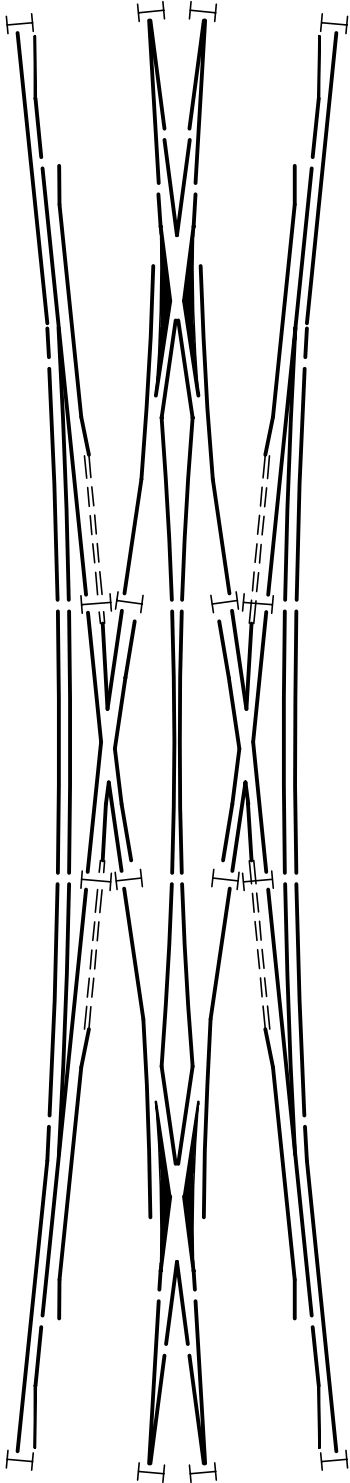

DOUBLE SLIP

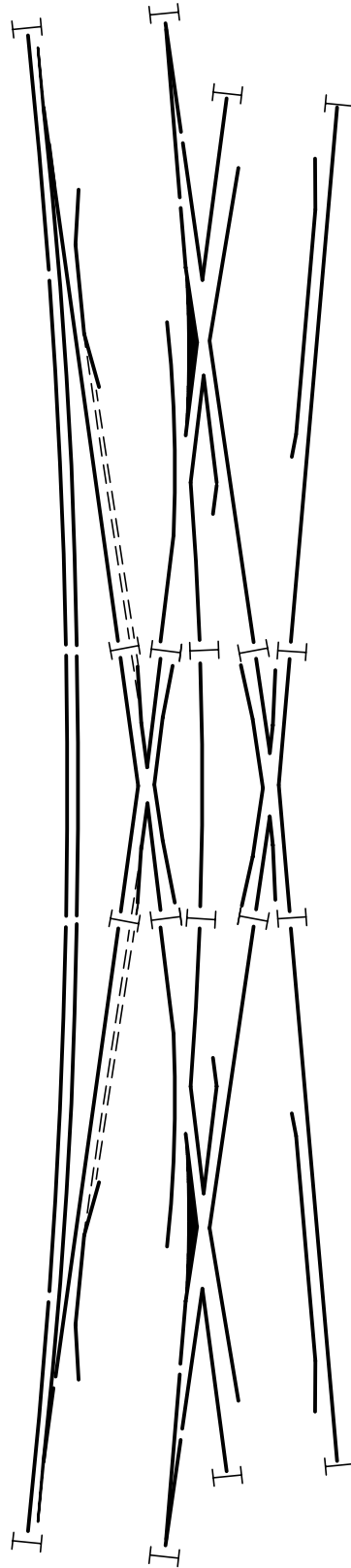

SINGLE SLIP

REMARKS:

1. I SHOWS POSSIBLE INSULATED JOINT POSITIONS.

TUMBLER WITH LOCKABLE
KNUCKLE – JOINTED ARM

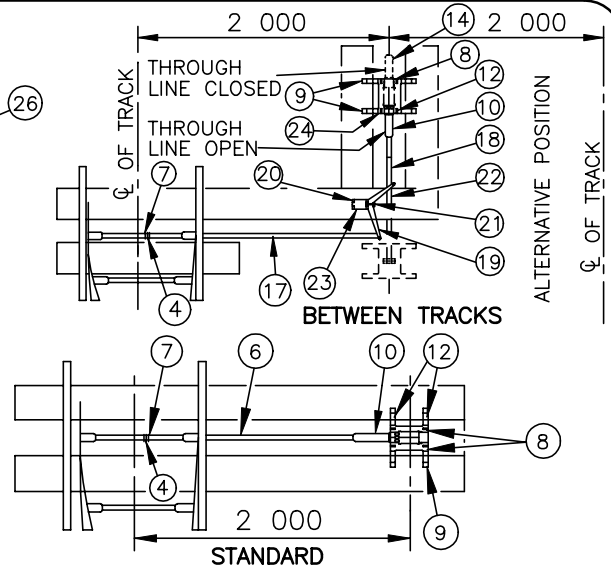
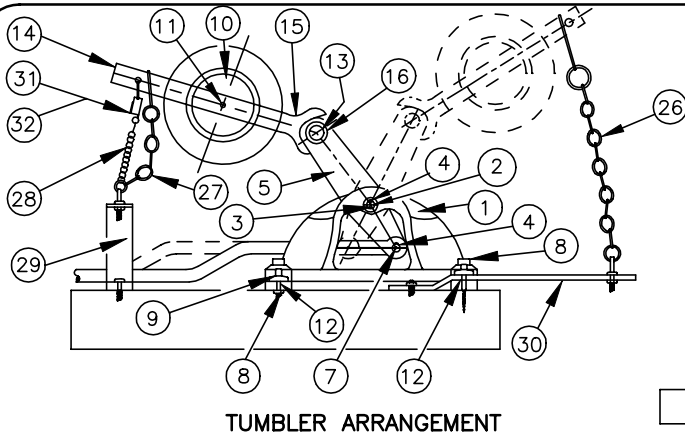

REMARKS:

1. SEE CLAUSE 5.6.7.

ITEM No.	DESCRIPTION	NUMBER PER CASE				DRAWING
		1	2	3	4	
1	SADDLE	1	1	1	1	TYPE E – 3301
2	SADDLE PIN	1	1	1	1	
3	WASHER FOR ITEMS 2 AND 7	6	4	4	4	
4	SPLIT PIN FOR ITEMS 2 AND 7	6	4	4	4	
5	KICK-OVER LEVER	1	1	1	1	
6	PULL ROD (2 285mm LONG)	1	1	1	1	
7	PULL ROD PIN	4	2	2	2	
8	BOLT AND LOCK NUT FOR ITEM 12	4	4	4	4	
9	COACH SCREW TYPE B	4	4	4	4	
10	COUNTERWEIGHT	1	1	1	1	TYPE E – 3301
11	COUNTERWEIGHT BOLT (SHORT)	–	1	1	1	
12	TUMBLER SUPPORT STRAP	2	2	2	2	
13	SPLIT PIN FOR ITEM 15	1	1	1	1	
14	COUNTERWEIGHT ARM	1	1	1	1	
15	KICK-OVER LEVER PIN	1	1	1	1	
16	WASHER FOR ITEM 15	1	1	1	1	
17	PULL ROD (1 475mm LONG)	1	–	–	–	CSEM 51-1-1/4
18	PULL ROD (915 mm LONG)	1	–	–	–	
19	BELL CRANK	1	–	–	–	
20	BELL CRANK SHOE	1	–	–	–	TYPE E – 3301
21	BELL CRANK SHOE PIN	1	–	–	–	
22	SPLIT PIN FOR ITEM 21	1	–	–	–	TYPE E – 3301
23	BOLT (Ø16mm X 180mm LONG) & NUT	4	–	–	–	
24	INDICATOR PLATE	1	–	–	–	TYPE E – 3301
25	COUNTERWEIGHT BOLT FOR ITEM 24	2	–	–	–	
26	LONG BRIDLE	1	1	–	1	TYPE E – 3157
27	SHORT BRIDLE	–	–	–	1	TYPE E – 3093
28	POINTS LOCK WITH CHAIN	–	–	–	1	TYPE E – 3178
29	BRIDGE	2	1	2	1	TYPE E – 3177
30	SADDLE FOR LONG BRIDGE	–	1	1	1	TYPE E – 3177
31	PATRICK LOCK (R H)	1	1	1	–	CSEM 411
32	PATRICK LOCK (L H)	–	–	1	–	CSEM 412

CASE 1 TURNOUT PROVIDED WITH POINTS INDICATOR, PATRICK LOCK AND LONG BRIDLE.
 CASE 2 TURNOUT PROVIDED WITH PATRICK LOCK AND LONG BRIDLE (NO INDICATOR).
 CASE 3 TURNOUT AT DETECTOR-LOCKED STATION PROVIDED WITH RIGHT-HAND AND LEFT-HAND PATRICK OR CHUBB LOCKS.
 CASE 4 TURNOUT PROVIDED WITH PADLOCK AND LONG BRIDLE.

TUMBLER WITH STIFF
COUNTER – WEIGHT ARM

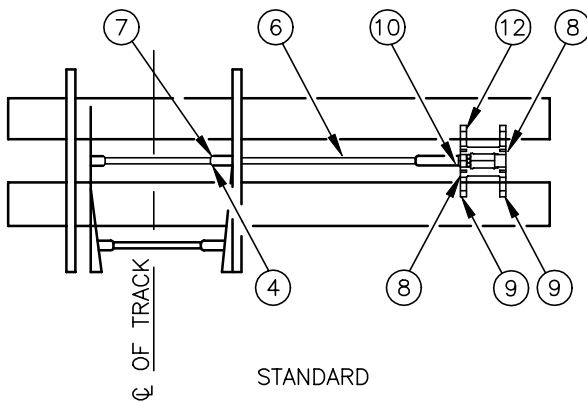
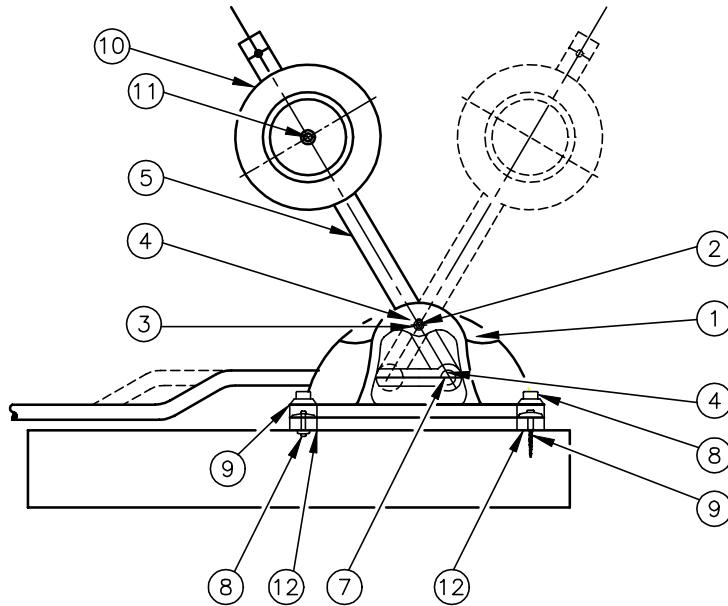

STANDARD
TUMBLER ARRANGEMENT

REMARKS:
1. SEE CLAUSE 5.6.7.

ITEM No.	DESCRIPTION	NUMBER OFF	DRAWING TYPE
1	SADDLE	1	E - 3287
2	SADDLE PIN	1	
3	WASHER FOR ITEM 2	2	
4	SPLIT PIN FOR ITEMS 2 AND 7	4	
5	KICK-OVER LEVER	1	
6	PULL ROD (2 285mm LONG)	1	
7	PULL-ROD PIN	2	
8	BOLT AND LOCK NUT FOR ITEM 12	4	
9	COACH SCREW TYPE B	4	E - 239M
10	COUNTERWEIGHT	1	E - 3287
11	COUNTERWEIGHT BOLT (SHORT)	1	E - 3287
12	TUMBLER SUPPORT STRAP	2	E - 3287

TUMBLER (COUNTERSUNK)
FOR HARBOURS

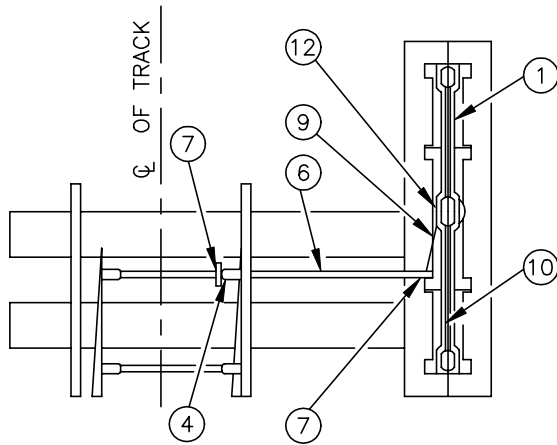
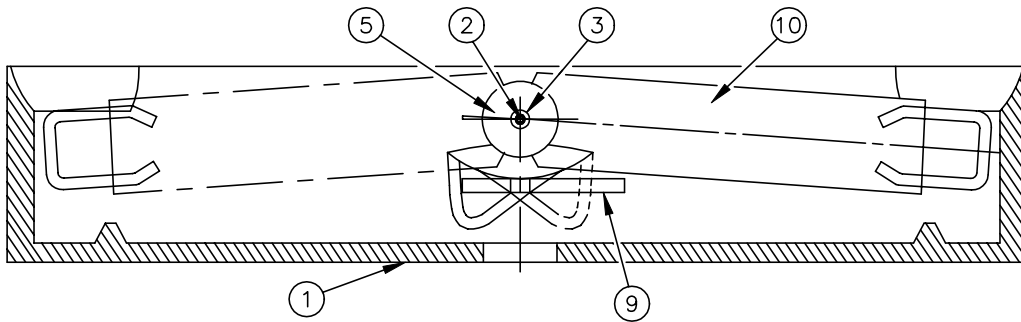

BETWEEN TRACKS

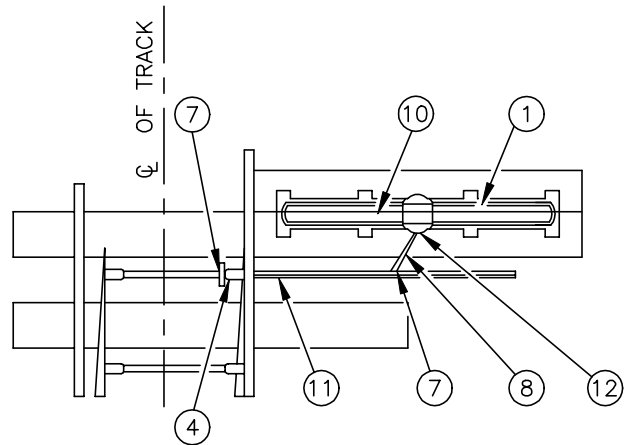

ALTERNATIVE

TUMBLER ARRANGEMENTS

REMARKS:

1. SEE CLAUSE 5.6.7.

ITEM No.	DESCRIPTION	NUMBER OFF	DRAWING TYPE
1	SADDLE	1	E - 3138
2	SADDLE PIN	1	
3	WASHER FOR ITEMS 2, 7 AND 12	4	
4	SPLIT PIN FOR ITEMS 2, 7 AND 12	3	
5	KICK-OVER LEVER	1	E - 3301
6	PULL ROD (915mm LONG)	1	
7	PULL ROD PIN	2	E - 3138
8	SPECIAL CRANK	1	
9	CRANK	1	
10	COUNTERWEIGHT	1	E - 3301
11	PULL ROD (1 475mm LONG)	1	
12	CRANK PIN	1	E - 3138

TUMBLER (STOKSTYF) WITH SPRING
LOADED LINKING MECHANISM

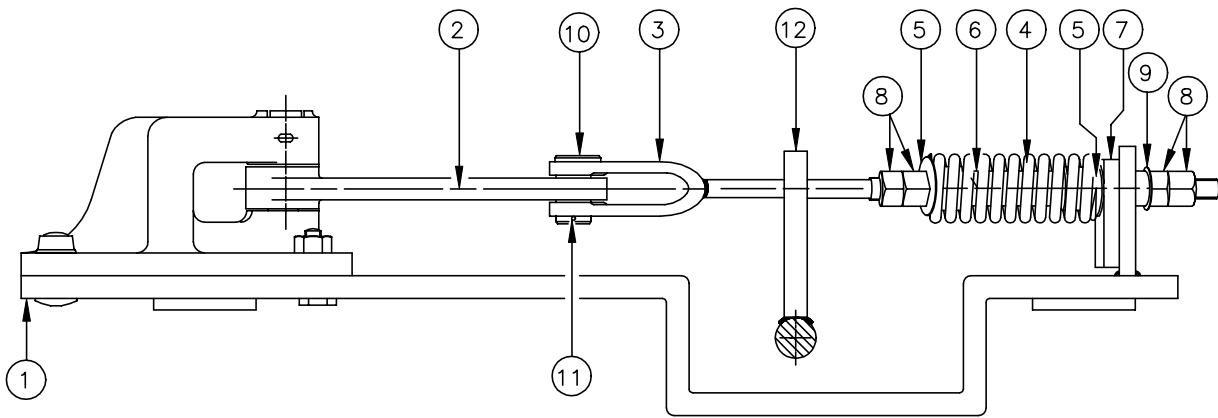

ASSEMBLY

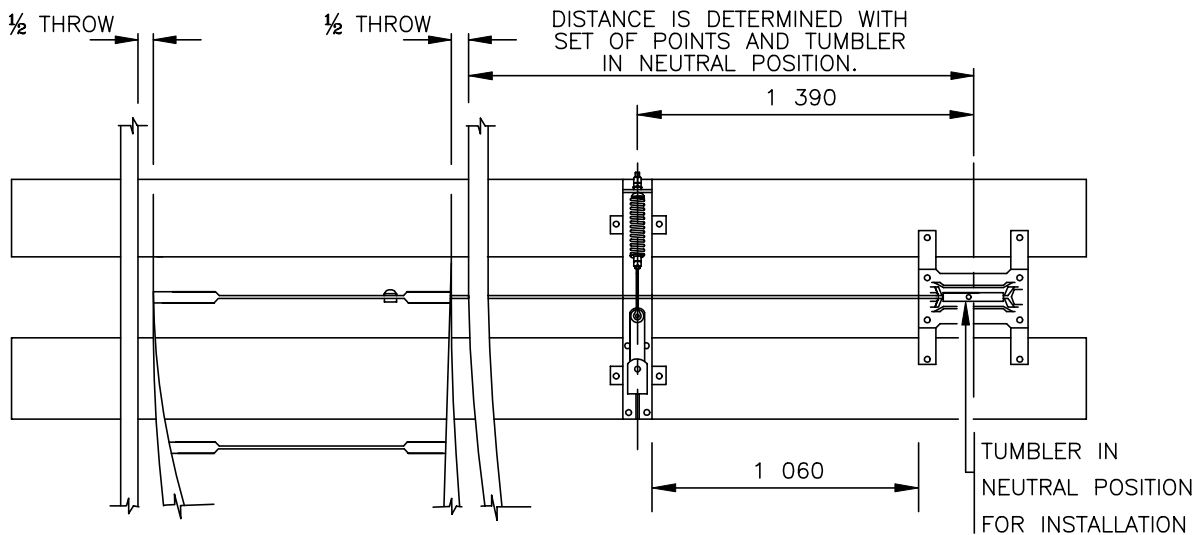

POSITION OF "STOKSTYF" SPRING LOADED LINKING MECHANISM

ITEM No.	DESCRIPTION	QUANTITIES	DRG. No. TYPE	STORES ITEM No.
1	BASE PLATE ASSEMBLY	1	E-3364 SHT 2-007	-
2	CRANK ARM	1	E-3364 SHT 2-004	-
3	PUSH ROD ASSEMBLY	1	E-3364 SHT 2-005	-
4	COMPRESSION SPRING	1	E-3364 SHT 3-002	-
5	SPRING CENTRALIZER	2	E-3364 SHT 3-001	-
6	PUSH ROD SLEEVE	1	E-3364 SHT 3-004	-
7	SWIVEL	1	E-3364 SHT 3-003	-
8	M24 NUT	4	-	01/015 552
9	M24 WASHER	1	-	01/007 275
10	CENTRE PIN	1	CSE M5629	59/009 566
11	SPLIT PIN	1	-	01/010 181
12	PULL ROD ASSEMBLY	1	E-3364 SHT 3-005	-

CUSHION STOP BLOCK

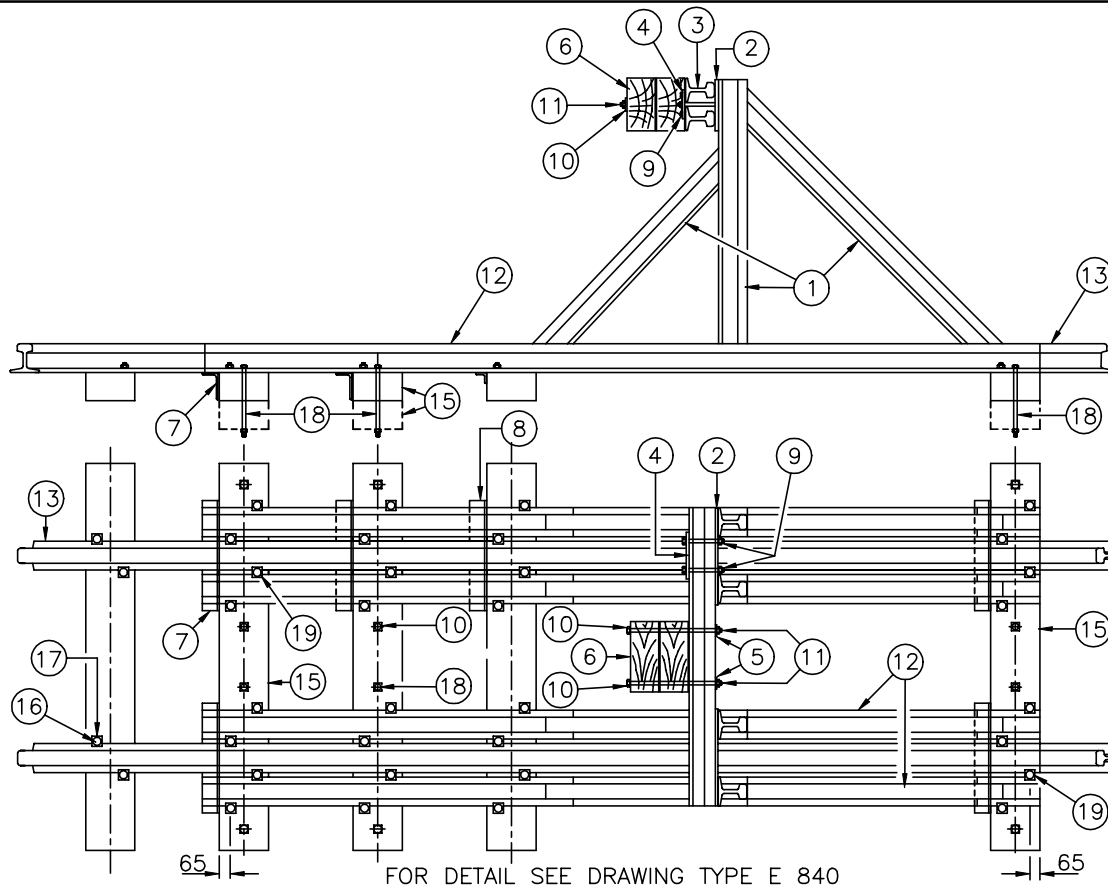

ITEM	DESCRIPTION	ITEM	DESCRIPTION
1	STRUT (ASSEMBLY)	11	BOLT AND NUT (M24, 455mm LONG)
2	STRUT GUSSET PLATE	12	STRUT FOOT
3	BUFFER BEAM (ASSEMBLY)	13	TRACK
4	LOCK PLATE	14	CUSHION STOP BLOCK (ASSEMBLY OF ITEMS 1-12)
5	BACK PLATE		
6	BUMPER BLOCK (WOOD)	15	WOODEN SLEEPER (2,1m LONG)
7	ANGLE IRON	16	COACH SCREW B
8	ANGLE IRON	17	COACH-SCREW WASHER
9	BOLT AND NUT (M24, 200mm LONG)	18	BOLT AND NUT FOR SLEEPER
10	WASHERS FOR DRAWING ITEMS NO's 11 & 18	19	FASTENING PLATE F1

REMARKS:

- CUSHION STOP BLOCK IS SUPPLIED COMPLETE WITH ITEMS 14, 17, AND 19. ITEMS 15 AND 16 TO BE SUPPLIED FROM OWN STOCK.
- IN YARDS WHERE HEAVY SHUNTING OCCURS AND WHERE CUSHION STOP BLOCKS ARE IN THE VICINITY OF BUILDINGS OR NEAR BOUNDARIES, ITEM 18 AND ADDITIONAL QUANTITIES OF ITEM 10 MUST BE ORDERED. ADDITIONAL SLEEPERS, ITEM 15, TO BE PROVIDED IN POSITIONS SHOWN IN DOTTED LINES.
- HEAVY SHUNTING:

A. GRADIENT	- STEEPER THAN 1:100	} DEPOT ENGINEER TO DECIDE
B. SPEED	- FASTER THAN WALKING PACE	
C. DENSITY	- HIGH DENSITY (ALL DAY)	
D. POOR BALLAST	- ASH, SOIL, GRAVEL, ETC.	
- AFTER EACH COLLISION, THE CUSHION STOP BLOCK IS TO BE MOVED TO THE NORMAL POSITION, INSPECTED FOR DEFECTS AND REPAIRED IF NECESSARY.

REPAIRS TO AND LENGTHENING OF EXISTING FENCES

TYPE OF FENCE	REFERENCE DRAWING TYPE
8 – WIRE FENCE	I – 41 OR I – 45 SHT 1

ERECTION OF NEW FENCES

TYPE OF FENCE	REFERENCE DRAWING TYPE
6 – WIRE LARGE STOCK FENCE	I – 45
8 – WIRE SMALL STOCK FENCE	I – 45

GATES

GATES FOR	REFERENCE DRAWING TYPE
6 AND 8 – WIRE FENCING	I – 45 SHT 2

GENERAL

DESCRIPTION	REFERENCE DRAWING TYPE
FENCING AT LAND BEACONS	I – 45
FENCING ALONG CURVED BOUNDARIES	I – 45
FENCING OF ENCLOSED AREAS	I – 45

SLEEPER DETAIL :
GENERAL

SLEEPER	TYPE	LENGTH (mm)	WIDTH (mm)	HEIGHT (mm)	MASS (kg)	REFERENCE DRAWING
P2	CONCRETE	2 057	254	230	215	E-3303 SH 1
PY	CONCRETE	2 200	300	232	278	E-3318 SH 1
F4	CONCRETE	2 057	254	244	215	E-3303 SH 2
FY	CONCRETE	2 200	300	258	282	E-3318 SH 2
WOOD	LAMINATED	2 100	250	195	72	—————
WOOD	LAMINATED	2 400	250	195	82	—————
WOOD	LAMINATED	2 700	250	195	92	—————
WOOD	LAMINATED	3 000	250	195	102	—————
WOOD	LAMINATED	3 400	250	195	116	—————
WOOD	LAMINATED	3 800	250	195	130	—————
WOOD	LAMINATED	4 200	250	195	143	—————
WOOD	LAMINATED	6 000	250	195	205	—————
STEEL	—————	2 060	260	87	63	E-3277

SLEEPER DETAIL :
48kg 1:12 TURNOUT :
CONCRETE SLEEPERS

SLEEPER NUMBER	USED ON TURNOUT (MARK)	MASS (kg)	LENGTH (mm)	SLEEPER NUMBER	USED ON TURNOUT (MARK)	MASS (kg)	LENGTH (mm)
1P	1 (LH & RH)	334	2 225	19PL	1 (LH)	385	2 565
2P	1 (LH & RH)	430	2 870	19PR	1 (RH)	386	2 570
3PL	1 (LH)	430	2 870	20PL	1 (LH)	390	2 600
3PR	1 (RH)	430	2 870	20PR	1 (RH)	390	2 600
4PL	1 (LH)	337	2 250	21PL	1 (LH)	395	2 635
4PR	1 (RH)	337	2 250	21PR	1 (RH)	395	2 635
5PL	1 (LH)	339	2 260	22PL	1 (LH)	401	2 670
5PR	1 (RH)	339	2 260	22PR	1 (RH)	401	2 670
6PL	1 (LH)	341	2 275	23PL	1 (LH)	406	2 705
6PR	1 (RH)	341	2 275	23PR	1 (RH)	406	2 705
7PL	1 (LH)	344	2 290	24PL	1 (LH)	411	2 740
7PR	1 (RH)	344	2 290	24PR	1 (RH)	412	2 745
8PL	1 (LH)	346	2 310	25PL	1 (LH)	418	2 780
8PR	1 (RH)	346	2 310	25PR	1 (RH)	418	2 785
9PL	1 (LH)	349	2 325	26PL	1 (LH)	423	2 820
9PR	1 (RH)	349	2 325	26PR	1 (RH)	424	2 825
10PL	1 (LH)	352	2 345	27PL	1 (LH)	430	2 865
10PR	1 (RH)	352	2 345	27PR	1 (RH)	430	2 865
11PL	1 (LH)	355	2 365	28PL	1 (LH)	436	2 905
11PR	1 (RH)	355	2 365	28PR	1 (RH)	436	2 910
12PL	1 (LH)	358	2 385	29PL	1 (LH)	443	2 950
12PR	1 (RH)	358	2 385	29PR	1 (RH)	443	2 950
13PL	1 (LH)	361	2 410	30PL	1 (LH)	449	2 995
13PR	1 (RH)	361	2 410	30PR	1 (RH)	449	2 995
14PL	1 (LH)	365	2 435	31PL	1 (LH)	456	3 040
14PR	1 (RH)	365	2 435	31PR	1 (RH)	456	3 040
15PL	1 (LH)	369	2 460	32PL	1 (LH)	462	3 080
15PR	1 (RH)	369	2 460	32PR	1 (RH)	462	3 080
16PL	1 (LH)	373	2 485	33PL	1 (LH)	469	3 125
16PR	1 (RH)	373	2 485	33PR	1 (RH)	469	3 125
17PL	1 (LH)	376	2 505	34PL	1 (LH)	476	3 170
17PR	1 (RH)	377	2 510	34PR	1 (RH)	476	3 170
18PL	1 (LH)	380	2 535	35PL	1 (LH)	483	3 220
18PR	1 (RH)	380	2 535	35PR	1 (RH)	483	3 220

REMARKS:

1. FOR REMARKS SEE ANNEXURE 30 SHEET 3

SLEEPER DETAIL :
48kg 1:12 TURNOUT :
CONCRETE SLEEPERS

SLEEPER NUMBER	USED ON TURNOUT (MARK)	MASS (kg)	LENGTH (mm)	SLEEPER NUMBER	USED ON TURNOUT (MARK)	MASS (kg)	LENGTH (mm)
36PL	1 (LH)	491	3 270	44PL	1 (LH)	546	3 640
36PR	1 (RH)	491	3 270	44PR	1 (RH)	546	3 640
37PL	1 (LH)	498	3 320	45PL	1 (LH)	555	3 695
37PR	1 (RH)	498	3 320	45PR	1 (RH)	555	3 695
38PL	1 (LH)	505	3 365	46PL	1 (LH)	563	3 750
38PR	1 (RH)	505	3 365	46PR	1 (RH)	563	3 750
39PL	1 (LH)	512	3 410	47PL	1 (LH)	570	3 800
39PR	1 (RH)	512	3 410	47PR	1 (RH)	570	3 800
40PL	1 (LH)	519	3 460	48PL	1 (LH)	578	3 855
40PR	1 (RH)	519	3 460	48PR	1 (RH)	578	3 855
41PL	1 (LH)	526	3 505	49P	1 (LH & RH)	587	3 910
41PR	1 (RH)	526	3 505	50P	1 (LH & RH)	594	3 960
42PL	1 (LH)	533	3 550	51P	1 (LH & RH)	602	4 015
42PR	1 (RH)	533	3 550	52P	1 (LH & RH)	611	4 070
43PL	1 (LH)	539	3 595	53P	1 (LH & RH)	619	4 125
43PR	1 (RH)	539	3 595	54P	1 (LH & RH)	274	1 825

REMARKS:

1. FOR TURNOUT CLASSIFICATION (TURNOUT MARK) SEE THE PERMANENT WAY MATERIAL MANUAL PART 1.
2. WIDTH OF SLEEPER = 250mm.
HEIGHT OF SLEEPER = 250mm.

ANNEXURE 30
SHEET 4 of 7
AMENDMENT

SLEEPER DETAIL :
S-60 / UIC-60 1:12 TURNOUT :
CONCRETE SLEEPERS

SLEEPER NUMBER	USED ON TURNOUT (MARK)	MASS (kg)	LENGTH (mm)	SLEEPER NUMBER	USED ON TURNOUT (MARK)	MASS (kg)	LENGTH (mm)
1	2, 3(a,b,c,d,e), 4	334	2 225	12F	4	368	2 455
2	2	431	2 870	12P	3, 3a, 3b, 3c, 3d, 3e	358	2 385
2F	4	431	2 870	13	2	361	2 405
2P	3, 3a, 3b, 3d	431	2 870	13F	4	368	2 455
2PH	3c, 3e	431	2 870	13P	3, 3a, 3b, 3c, 3d, 3e	361	2 405
3	2	431	2 870	14	2	365	2 430
3F	4	431	2 870	14F	4	368	2 455
3P	3, 3a, 3b, 3d, 3e	431	2 870	14P	3, 3a, 3b, 3c, 3d, 3e	365	2 430
3PH	3c	431	2 870	15	2	368	2 455
4	2	337	2 245	15F	4	368	2 455
4F	4	351	2 340	15P	3, 3a, 3b, 3c, 3d, 3e	368	2 455
4P	3, 3a, 3b, 3c, 3d, 3e	337	2 245	16	2, 3(a,b,d,e), 4	372	2 480
5	2	339	2 260	16PH	3c	372	2 480
5F	4	351	2 340	17	2, 3(a,b,c,d,e), 4	376	2 505
5P	3, 3a, 3b, 3c, 3d, 3e	339	2 260	18	2, 3(a,b,c,d,e), 4	380	2 535
6	2	341	2 275	19	2, 3(a,b,c,d,e), 4	385	2 565
6F	4	351	2 340	20	2, 3(a,b,c,d,e), 4	389	2 595
6P	3, 3a, 3b, 3c, 3d, 3e	341	2 275	21	2, 3(a,b,c,d,e), 4	395	2 630
7	2	344	2 290	22	2, 3(a,b,c,d,e), 4	400	2 665
7F	4	351	2 340	23	2, 3(a,b,c,d,e), 4	405	2 700
7P	3, 3a, 3b, 3c, 3d, 3e	344	2 290	24	2, 3(a,b,c,d,e), 4	411	2 740
8	2	346	2 305	25	2, 3(a,b,c,d,e), 4	416	2 775
8F	4	351	2 340	26	2, 3(a,b,c,d,e), 4	423	2 820
8P	3, 3a, 3b, 3c, 3d, 3e	346	2 305	27	2, 3(a,b,c,d,e), 4	429	2 860
9	2	349	2 325	28	2, 3(a,b,c,d,e), 4	435	2 900
9F	4	351	2 340	29	2, 3(a,b,c,d,e), 4	442	2 945
9P	3, 3a, 3b, 3c, 3d, 3e	349	2 325	30	2, 3(a,b,c,d,e), 4	449	2 990
10	2	351	2 340	31	2, 3(a,b,c,d,e), 4	456	3 040
10F	4	351	2 340	32	2, 3(a,b,c,d,e), 4	462	3 080
10P	3, 3a, 3b, 3c, 3d, 3e	351	2 340	33	2, 3(a,b,c,d,e), 4	468	3 120
11	2	354	2 360	34	2, 3(a,b,c,d,e), 4	476	3 170
11F	4	368	2 455	35	2, 3(a,b,c,d,e), 4	482	3 215
11P	3, 3a, 3b, 3c, 3d, 3e	354	2 360	36	2, 3(a,b,c,d,e), 4	490	3 265
12	2	358	2 385	37	2, 3(a,b,c,d,e), 4	497	3 315

REMARKS:

1. FOR REMARKS SEE ANNEXURE 30 SHEET 5

SLEEPER DETAIL :
S-60 / UIC-60 1:12 TURNOUT :
CONCRETE SLEEPERS

SLEEPER NUMBER	USED ON TURNOUT (MARK)	MASS (kg)	LENGTH (mm)	SLEEPER NUMBER	USED ON TURNOUT (MARK)	MASS (kg)	LENGTH (mm)
38	2, 3(a,b,c,d,e), 4	504	3 360	47	2, 3(a,b,c,d,e), 4	570	3 800
39	2, 3(a,b,c,d,e), 4	511	3 405	48	2, 3(a,b,c,d,e), 4	578	3 855
40	2, 3(a,b,c,d,e), 4	518	3 455	49	2, 3(a,b,c,d,e), 4	587	3 910
41	2, 3(a,b,c,d,e), 4	526	3 505	50	2, 3(a,b,c,d,e), 4	595	3 965
42	2, 3(a,b,c,d,e), 4	532	3 545	51	2, 3(a,b,c,d,e), 4	602	4 015
43	2, 3(a,b,c,d,e), 4	539	3 590	52	2, 3(a,b,c,d,e), 4	611	4 070
44	2, 3(a,b,c,d,e), 4	546	3 640	53PH	3c	431	2 870
45	2, 3(a,b,c,d,e), 4	554	3 695	84	2, 3(a,b,c,d,e), 4	274	1 825
46	2, 3(a,b,c,d,e), 4	562	3 745				

REMARKS:

1. FOR TURNOUT CLASSIFICATION (TURNOUT MARK) SEE THE PERMANENT WAY MATERIAL MANUAL PART 1.
2. WIDTH OF SLEEPER = 250mm.
HEIGHT OF SLEEPER = 250mm.
3. USED ON LEFT HAND AS WELL AS RIGHT HAND TURNOUTS.

SLEEPER DETAIL :
S-60 / UIC-60 1:20 TURNOUT :
CONCRETE SLEEPERS

SLEEPER NUMBER	USED ON TURNOUT (MARK)	MASS (kg)	LENGTH (mm)	SLEEPER NUMBER	USED ON TURNOUT (MARK)	MASS (kg)	LENGTH (mm)
1	2, 3a, 3b, 3c, 5	334	2 225	19	2	362	2 410
2	2	431	2 870	19P	3a, 3b, 3c	362	2 410
2P	3a, 3b, 3c	431	2 870	19P-1	5	362	2 410
2PH	5	431	2 870	20	2	363	2 420
3	2	431	2 870	20P	3a, 3b, 3c	363	2 420
3P	3a, 3b, 3c, 5	431	2 870	20P-1	5	363	2 420
4	2	336	2 240	21	2	366	2 440
4P	3a, 3b, 3c, 5	336	2 240	21P	3a, 3b, 3c	366	2 440
5	2	343	2 285	21P-1	5	366	2 440
5P	3a, 3b, 3c, 5	343	2 285	22	2	368	2 450
6	2	338	2 255	22P	3a, 3b, 3c	368	2 450
6P	3a, 3b, 3c, 5	338	2 255	22P-1	5	368	2 450
7	2	340	2 265	23	2, 3a, 3b, 3c, 5	370	2 465
7P	3a, 3b, 3c, 5	340	2 265	24	2, 3a, 3b, 3c, 5	372	2 480
8	2	350	2 335	25	2, 3a, 3b, 3c, 5	375	2 500
8P	3a, 3b, 3c, 5	350	2 335	26	2, 3a, 3b, 3c, 5	377	2 515
9	2	343	2 285	27	2, 3a, 3b, 3c, 5	380	2 530
9P	3a, 3b, 3c, 5	343	2 285	28	2, 3a, 3b, 3c, 5	383	2 550
10	2	392	2 610	29	2, 3a, 3b, 3c, 5	386	2 570
10P	3a, 3b, 3c, 5	392	2 610	30	2, 3a, 3b, 3c, 5	389	2 590
11	2	566	3 770	31	2, 3a, 3b, 3c, 5	391	2 605
11P	3a, 3b, 3c, 5	566	3 770	32	2, 3a, 3b, 3c, 5	394	2 625
12	2	348	2 320	33	2, 3a, 3b, 3c, 5	397	2 645
12P	3a, 3b, 3c, 5	348	2 320	34	2, 3a, 3b, 3c, 5	401	2 670
13	2	350	2 330	35	2, 3a, 3b, 3c, 5	404	2 690
13P	3a, 3b, 3c, 5	350	2 330	36	2, 3a, 3b, 3c, 5	407	2 710
14	2	351	2 340	37	2, 3a, 3b, 3c, 5	410	2 730
14P	3a, 3b, 3c, 5	351	2 340	38	2, 3a, 3b, 3c, 5	413	2 755
15	2	354	2 360	39	2, 3a, 3b, 3c, 5	416	2 775
15P	3a, 3b, 3c, 5	354	2 360	40	2, 3a, 3b, 3c, 5	420	2 800
16	2	356	2 370	41	2, 3a, 3b, 3c, 5	424	2 825
16P	3a, 3b, 3c, 5	356	2 370	42	2, 3a, 3b, 3c, 5	428	2 850
17	2	357	2 380	43	2, 3a, 3b, 3c, 5	431	2 870
17P	3a, 3b, 3c, 5	357	2 380	44	2, 3a, 3b, 3c, 5	434	2 895
18	2	359	2 390	45	2, 3a, 3b, 3c, 5	438	2 920
18P	3a, 3b, 3c	359	2 390	46	2, 3a, 3b, 3c, 5	442	2 945
18P-1	5	359	2 390	47	2, 3a, 3b, 3c, 5	446	2 970

REMARKS:

1. FOR REMARKS SEE ANNEXURE 30 SHEET 7

SLEEPER DETAIL :
S-60 / UIC-60 1:20 TURNOUT :
CONCRETE SLEEPERS

SLEEPER NUMBER	USED ON TURNOUT (MARK)	MASS (kg)	LENGTH (mm)	SLEEPER NUMBER	USED ON TURNOUT (MARK)	MASS (kg)	LENGTH (mm)
48	2, 3a, 3b, 3c, 5	449	2 995	66	2	533	3 555
49	2, 3a, 3b, 3c, 5	454	3 025	66P	3a, 3b, 3c, 5	533	3 555
50	2, 3a, 3b, 3c, 5	458	3 050	67	2	539	3 590
51	2, 3a, 3b, 3c, 5	461	3 075	67P	3a, 3b, 3c, 5	539	3 590
52	2, 3a, 3b, 3c, 5	467	3 110	68	2	542	3 615
53	2, 3a, 3b, 3c, 5	471	3 140	68P-LH	3a, 3b, 3c, 5 (LH)	542	3 615
54	2, 3a, 3b, 3c, 5	476	3 175	68P-RH	3a, 3b, 3c, 5 (RH)	542	3 615
55	2, 3a, 3b, 3c, 5	481	3 205	69	2	547	3 645
56	2	486	3 240	69P-LH	3a, 3b, 3c, 5 (LH)	547	3 645
56P	3a, 3b, 3c, 5	486	3 240	69P-RH	3a, 3b, 3c, 5 (RH)	547	3 645
57	2	587	3 915	70	2	551	3 670
57P	3a, 3b, 3c, 5	587	3 915	70P-LH	3a, 3b, 3c, 5 (LH)	551	3 670
58	2	587	3 915	70P-RH	3a, 3b, 3c, 5 (RH)	551	3 670
58P	3a, 3b, 3c, 5	587	3 915	71	2, 3a, 3b, 3c, 5	556	3 705
59	2	498	3 320	72	2, 3a, 3b, 3c, 5	560	3 735
59P	3a, 3b, 3c, 5	498	3 320	73	2, 3a, 3b, 3c, 5	566	3 770
60	2	503	3 350	74	2, 3a, 3b, 3c, 5	570	3 800
60P	3a, 3b, 3c, 5	503	3 350	75	2, 3a, 3b, 3c, 5	575	3 835
61	2	507	3 380	76	2, 3a, 3b, 3c, 5	580	3 865
61P	3a, 3b, 3c, 5	507	3 380	77	2, 3a, 3b, 3c, 5	585	3 900
62	2	513	3 420	78	2, 3a, 3b, 3c, 5	590	3 930
62P	3a, 3b, 3c, 5	513	3 420	79	2, 3a, 3b, 3c, 5	596	3 965
63	2	518	3 450	80	2, 3a, 3b, 3c, 5	600	3 995
63P	3a, 3b, 3c, 5	518	3 450	81	2, 3a, 3b, 3c, 5	605	4 030
64	2	523	3 485	82	2, 3a, 3b, 3c, 5	610	4 060
64P	3a, 3b, 3c, 5	523	3 485	83	2, 3a, 3b, 3c, 5	615	4 095
65	2	528	3 520	84	2, 3a, 3b, 3c, 5	274	1 825
65P	3a, 3b, 3c, 5	528	3 520				

REMARKS:

- FOR TURNOUT CLASSIFICATION (TURNOUT MARK) SEE THE PERMANENT WAY MATERIAL MANUAL PART 1.
MARK 2 = UNIQUE NOS 60209495(LH) AND 60209496(RH).
MARK 3a = UNIQUE NOS 60209497(LH) AND 60209498(RH).
- WIDTH OF SLEEPER = 250mm.
HEIGHT OF SLEEPER = 250mm.
- USED ON LEFT HAND AS WELL AS RIGHT HAND TURNOUTS, EXCEPT WHERE SHOWN DIFFERENTLY.