

UPDATED: 9/2/2011

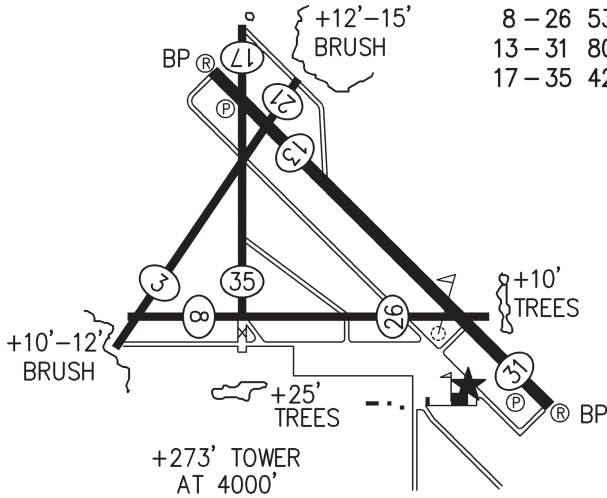

RUNWAY DATA:

3-21 5000' x 150'
 8-26 5317' x 150'
 13-31 8001' x 200' MIRL
 17-35 4200' x 150'

Lat: N 26° 09.97'
 Lon: W 97° 20.75'

Elev: 19' MSL
 TPA: STD

Sectional: BROWNSVILLE
 Downtown to Apt: 10 nm/W

Owner: CAMERON COUNTY
 CO. COURTHOUSE, 964E
 BROWNSVILLE TX 78520
Phone: 956-544-0830

Manager: MARTY PENA
 CAMERON CO. COURTHOUSE
 BROWNSVILLE TX 78520
 956-574-8767
 956-574-8771

ATTENDANCE SCHEDULE: 8:00AM-5:00PM

FUEL: JET A 100LL

REPAIRS: Airframe: MAJOR Power Plant: MAJOR

LIGHTS: DSK-DWN

UNICOM/CTAF: 122.8

ASOS: 118.525 / 956-233-5740

REMARKS: FOOD-LODGING (14 MI); CAR RENTAL (PRIOR NOTICE); PAJA

FIXED BASE OPERATOR: SOUTHWIND AIRLINES INC. 956-233-4424

