

ANGLETON, BAILES (7R9)

UPDATED: 11/14/2011

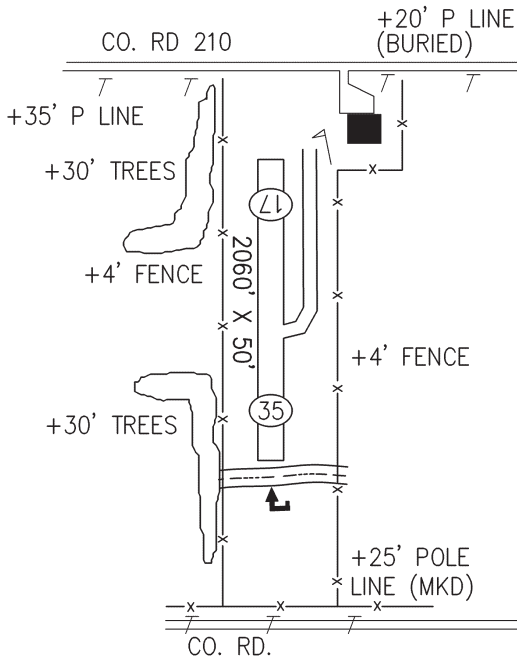

Lat: N 29° 10.00'
Lon: W 95° 24.06'

Elev: 21' MSL
TPA: STD

Sectional: HOUSTON
Downtown to Apt: 02 nm/E

Owner: R.L. BAILES JR., ESTATE
 817 N VALDERAS
 ANGLETON, TX 77515
Phone: 979-849-5173

Manager: DANNY STILL
 408 CR 210
 ANGLETON, TX 77515
 979-549-6848

ATTENDANCE SCHEDULE: UNATNDD

FUEL: NO

REPAIRS: NO

LIGHTS: NO

UNICOM/CTAF: 122.9

REMARKS: FOOD/LODGING (2 MI)

