

ENGLISH
VERSION

RULE BOOK

GENERAL COMPETITION GUIDELINES

COMPETITION FORMAT MANUAL



IBJJF

INTERNATIONAL BRAZILIAN JIU-JITSU FEDERATION

www.ibjff.com

CONTENTS

PAGE 3

RULE BOOK

PAGE 31

GENERAL COMPETITION GUIDELINES

PAGE 37

COMPETITION FORMAT MANUAL

RULE BOOK

1 ARTICLE 1 – REFEREEING

1.1 Authority of Referee

1.1.1 The referee is the highest authority in a match.

1.1.2 The referee ruling on the result of each match is uncontestable.

1.1.3 The ruling on the result of a match may only be changed under the following circumstances:

- If the score on the board has been misread;
- If the athlete declared winner submitted his/her opponent using an illegal hold previously unnoticed by the referee.

1.1.4 To overturn the outcome of a match, the following conditions should be observed:

- The referee can consult the event's director of refereeing, but the final decision as to whether to overturn or not overturn a result is the referee's to make;
- The director of refereeing should consult the event's center table regarding how the bracket has progressed and may only authorize the overturning of a result if the bracket has not progressed to the next stage.

1.2 Refereeing Format

1.2.1 The organizers of the tournament may opt to appoint three referees for a single match whenever they deem it necessary.

- In this case, two corner referees shall be seated in chairs placed at opposing corners of the match area.
- The corner referees bear the same powers as the central referee – and all or any points, advantage points or penalty points awarded must be confirmed by at least two of the three referees.
- Should there be a consensus between the corner referees and the central referee, the corner referees shall remain seated in the chairs at the corners of the match area.
- Should there be a conflict of opinion with the central referee, the corner referees should stand up and signal for points, advantage points or penalty points to be awarded or subtracted, using gestures predefined in this rule book.
- Should there be a discrepancy between all three referees on points to be awarded for the same move, the intermediary decision shall count (e.g., when one referee awards a guard pass, the second awards an advantage point and the third asks that points be subtracted; the advantage point shall be recorded on the scoreboard).
- In the event of a match ending in a draw, the central referee should maintain his/her position and the corner referees should remain in their seats, determining the result of the match by signaling with their arms which of the two athletes they consider to have won the bout.

1.3 Referee Duties

1.3.1 It is the referee's duty to summon the athletes into the match area to initiate the match.

1.3.2 It is the referee's duty to do a final check to be sure requirements – such as attire, hygiene, etc. – are being met. Should an athlete not meet any of the requirements, it is the referee's duty to determine whether the requirement can be met within a determined amount of time.

1.3.3 It is the referee's duty to position the athletes in the match area prior to the match.

- Points awarded to the athlete on the referee's right shall be signaled using the referee's right arm, which is distinguished from the left arm by a green and yellow armband, indicating the points should be marked on the green and yellow section of the scoreboard.

- Points awarded the athlete on the referee's left shall be signaled using the referee's left arm, which does not bear an armband, and the points will be marked on the uncolored section of the scoreboard.

1.3.4 It is the referee's duty to position the athletes according to the color of their gis.

- Should both athletes be wearing gis of the same color, the first athlete summoned shall be positioned on the referee's right and be provided a green and yellow belt for identification, to be worn in addition to the belt already fastened around his/her waist.
- Should one athlete be wearing a white gi and the other a blue or black gi, the athlete in blue or black shall be positioned on the referee's right.
- Should one athlete be wearing a black gi and the other athlete a blue gi, the athlete in blue shall be positioned on the referee's right.

1.3.5 It is the referee's duty to call a start to the match.

1.3.6 It is the referee's duty to intervene in a match when he/she deems it necessary.

1.3.7 It is the referee's duty to make sure the athletes fulfill their obligation to compete within the match area.

- When 2/3 of the athletes' bodies are outside the match area in a stabilized position on the ground, the referee should call a time out and, noting the position of each athlete, restart the match at the center of the match area with the athletes in positions identical to those they were in at the moment of stoppage.
- When 2/3 of the athletes' bodies are outside the match area on foot or in a non-stabilized position on the ground, the referee should call a time out and restart the two athletes on their feet at the center of the match area.
- When an athlete has a submission hold in place in the outlying safety area, the referee should not interrupt the match.
- When an athlete has a submission hold in place and the opponent defends by moving to outside the outlying safety area, the referee should call a time out and restart the match at the center of the match area with the athletes standing. In this case, when the referee deems it clearly apparent the athlete under attack initiated the movement that led to exiting the match area, he/she shall signal for 2 (two) points to be added to the score of the athlete performing the submission hold, as described in item 3.1.1.

1.3.8 It is the duty of referees overseeing under-12-years-old-division matches to protect the athlete's spinal column by positioning themselves behind the child when lifted off the ground by the opponent, as in the case of a triangle or closed guard.

1.3.9 It is the referee's duty to signal every or any penalty, advantage or point scored by each athlete.

1.3.10 It is the referee's duty to caution or disqualify athletes.

1.3.11 It is the referee's duty to summon medical staff to the match area.

1.3.12 It is the referee's duty to call an end to the match upon reaching regulation time.

1.3.13 It is the referee's duty to announce the result of the match.

1.3.14 It is the referee's duty to raise the arm of the winner of the match and only that of the winner, even in the event of two athletes from the same academy coming to an agreement designating the match result.

1.4 Referee Gestures and Verbal Commands

1.4.1 Referees shall use an array of gestures and verbal commands to communicate with the athletes and table officials during the match. Hereunder the gestures and verbal commands are listed according to match circumstances:

MATCH CIRCUMSTANCES:

Summon athletes to match area.

GESTURE:

Arms raised to shoulder height and bent at 90-degree angle with palms of hands facing inwards, motioning by extending arms and returning to initial position.

VERBAL COMMAND:

—



MATCH CIRCUMSTANCES:

Start of match.

GESTURE:

Arm extended forward and then lowered to point vertically toward the ground.

VERBAL COMMAND:

COMBATE
(com-ba-tchee)



MATCH CIRCUMSTANCES:

Match stoppage, end of match, and timeout.

GESTURE:

Arms open and raised at shoulder height.

VERBAL COMMAND:

PAROU
(pa-row)



MATCH CIRCUMSTANCES:

First warning for lack of combativeness (stalling).

GESTURE:

Elbows pointing forward at chest height with hands holding forearms, followed by arm corresponding with warned athlete pointing diagonally towards ground.

VERBAL COMMAND:

LUTE
(lu-tchee)



MATCH CIRCUMSTANCES:

Further warning for lack of combativeness (stalling).

GESTURE:

Elbows pointing forward at chest height with hands holding forearms.

VERBAL COMMAND:

LUTE
(lu-tchee)



MATCH CIRCUMSTANCES:

Penalty.

GESTURE:

Arms parallel at chest height making circular motion in the air, followed by arm corresponding with penalized athlete being raised to shoulder height with clenched fist.

VERBAL COMMAND:

—



MATCH CIRCUMSTANCES:

Disqualification.

GESTURE:

Arms over head with forearms crossed and fists clenched, followed by arm corresponding with disqualified athlete pointing to athlete's belt.

VERBAL COMMAND:

—

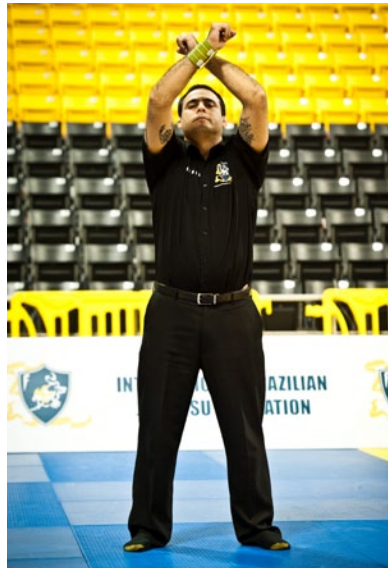

MATCH CIRCUMSTANCES:

Advantage.

GESTURE:

Arm corresponding with athlete to be awarded advantage point extending parallel to mat with hand open and palm facing downwards.

VERBAL COMMAND:

—



MATCH CIRCUMSTANCES:

2 (two) points:

takedown, sweep, and knee on belly.

GESTURE:

Hand of arm corresponding with athlete to be awarded points raised and pointer and middle fingers extended.

VERBAL COMMAND:

—



MATCH CIRCUMSTANCES:

3 (three) points: guard pass.

GESTURE:

Hand of arm corresponding with athlete to be awarded points raised and pointer, middle, and ring fingers extended.

VERBAL COMMAND:

–

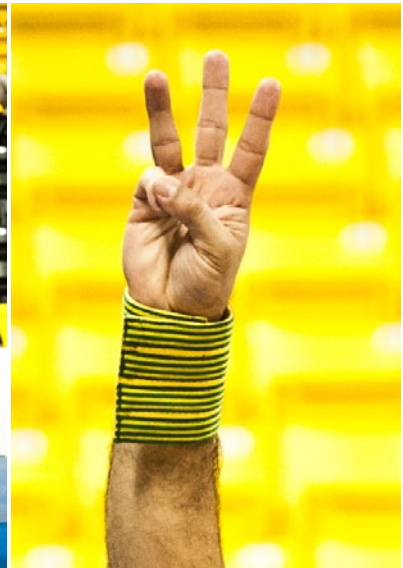

MATCH CIRCUMSTANCES:

4 (four) points:

Mount and back control.

GESTURE:

Hand of arm corresponding with athlete to be awarded points raised and pointer, middle, ring, and pinkie fingers extended.

VERBAL COMMAND:

–



MATCH CIRCUMSTANCES:

Point deduction.

GESTURE:

Arm corresponding with athlete to be deducted points at shoulder height with palm open.

VERBAL COMMAND:

–



MATCH CIRCUMSTANCES:

Announcement of match result.

GESTURE:

Arm of winning athlete raised while facing judges' table and the arm of losing athlete held downwards.

VERBAL COMMAND:

—



MATCH CIRCUMSTANCES:

Direct athlete to re-adjust gi.

GESTURE:

Arms crossed downwards at waist height, extending arm to indicate athlete's belt.

VERBAL COMMAND:

—



MATCH CIRCUMSTANCES:

Direct athlete to re-tie belt.

GESTURE:

Hands at waist level simulating tightening of knot on imaginary belt and indicating by extending arm and pointing to athlete's waist.

VERBAL COMMAND:

—



MATCH CIRCUMSTANCES:

Caution athlete to remain within match area.

GESTURE:

After pointing to the athlete with arms extended towards his/her waist, hand at shoulder height with open palms making a circular motion.

VERBAL COMMAND:

–



MATCH CIRCUMSTANCES:

Instruct athlete to stand up.

GESTURE:

Indicate with extended arm the athlete who must stand up, followed by raising arm to shoulder height.

VERBAL COMMAND:

–



MATCH CIRCUMSTANCES:

Instruct athlete to return to ground in position appointed by referee.

GESTURE:

Arm corresponding with athlete extended to shoulder height, followed by arm pointing diagonally across body toward ground.

VERBAL COMMAND:

–



2 RENDERING DECISIONS

2.1 Match decisions shall be issued in the following forms:

- Submission
- Stoppage
- Disqualification
- Loss of consciousness
- Score
- Referee decision
- Random pick

2.2 Submission

- 2.2.1 When an athlete taps twice with his/her hand on the opponent, ground, or his/herself in a clear and apparent manner.
- 2.2.2 When the athlete taps the ground twice with his/her foot, when arms are trapped by opponent.
- 2.2.3 When the athlete verbally withdraws, requesting the match be stopped.
- 2.2.4 When the athlete screams or emits noise expressing pain while trapped in a submission hold.

2.3 Stoppage

- 2.3.1 When one of the athletes alleges to be suffering from cramps, the opponent shall be declared winner of the match.
- 2.3.2 When the referee perceives that a hold in place may expose the athlete to serious physical injury.
- 2.3.3 When the doctor deems one of the athletes to be unable to continue a match due to injury rendered by the opponent using a legal hold.
- 2.3.4 When an athlete presents bleeding that cannot be contained after being treated by the doctor on 2 (two) occasions, to which each athlete has the right and should be provided upon the referee's request.
- 2.3.5 When an athlete vomits or loses control of basic bodily functions, with involuntary urination or bowel incontinence.

2.4 Disqualification

- 2.4.1 When one or both athletes commit an infraction addressed in Article 6, the referee shall apply the penalties addressed in Article 9.

2.5 Loss of Consciousness

- 2.4.1 The athlete shall be declared to have lost the match upon losing consciousness due to a legal hold applied by the opponent or due to an accident not stemming from an illegal maneuver by the opponent.
- Note:** Athletes who lose consciousness because of head trauma should not be allowed to compete again in the same tournament and should be directed to undergo treatment from medical staff.

2.6 Scoring

- 2.6.1 The athlete with the most points shall be declared winner when the match has reached regulation time or in the event of the match being stopped due to both athletes suffering injuries.
- 2.6.2 The referee shall award athletes points according to positions achieved, as shown in the table below.

04 POINTS	03 POINTS	02 POINTS
Mount Back control	Guard pass	Takedown Sweep Knee on belly

2.6.3 Advantages: When there is a draw in the number of points, the athlete with the most advantage points shall be declared the winner.

2.6.4 Penalties: When there is a draw in the number of points and advantage points, the athlete with the least penalty points counted against him/her shall be declared the winner.

2.7 Referee Decisions

2.7.1 If at the end of a match both athletes have the same number of points, advantage points and penalties, it is the duty of the referee or referees (when there are three referees overseeing a match) to declare a winner.

2.7.2 To determine the winner, the referee should take note of which athlete displayed greater offense during the match and came closest to achieving possible point- or submission-scoring positions.

2.8 Random Pick

2.8.1 In the event of both athletes suffering accidental injury in a semifinal or final match where the score is tied at the moment of the accident and neither athlete is able to continue in the contest, the result shall be determined by random pick.

NOTES

3 POINT SCORING

3.1 Points shall be awarded by the central referee of a match whenever an athlete stabilizes a position for 3 (three) seconds, with exception to takedowns where the opponent lands with his/her back on the ground or sideways.

3.1.1 When the proper defensive counter for a submission hold results in exiting the match area, the referee shall signal 2 (two) points be awarded to the athlete applying the submission hold (as addressed in item 1.3.7).

3.2 Matches should unfold as a progression of positions of technical control that ultimately result in a submission hold. Therefore athletes who voluntarily relinquish a position, in order to again score points using the same position for which points have already been awarded, shall not be awarded points upon achieving the position anew.

3.3 Athletes who arrive at a point-scoring position while caught in a submission hold shall only be awarded points once they have freed themselves from the attack and stabilized the position for 3 (three) seconds. Only in the case of takedowns where the opponent lands on his/her back or side – and only once the attacking hold has been released – shall points be awarded immediately.

3.4 Athletes who, in defending a sweep, return their opponent back-down or sideways on the ground shall not be awarded the takedown-related two points or advantage point.

3.5 Athletes defending standing-back mount, where the opponent has one or two hooks in place, shall not be awarded the takedown-related two points or advantage point.

3.6 Athletes who begin a takedown movement before the opponent pulls guard shall be awarded two points or an advantage point for the move.

3.7 When an athlete has a grip on his/her opponent's pants and the opponent pulls open guard, the athlete with the grip on the pants shall immediately be awarded two points for the takedown if the opponent lands with his/her back on the ground.

3.7.1 If the opponent lands in seated position, the two points shall only be conceded after the position has been stabilized for 3 (three) seconds.

3.7.2 Still related to item 3.7, if the opponent pulls closed guard and remains suspended in the air, the athlete will have to put the opponent's back on the ground within 3 (three) seconds for points for the takedown to be awarded.

3.8 Athletes shall be awarded cumulative points when they progress through a number of point-scoring positions, as long as the three-second positional control from the final point-scoring position is a continuation of the positional control from the point-scoring positions from earlier in the sequence. In this case, the referee shall count only 3 (three) seconds of control at the end of the sequence before signaling the points be scored (e.g., guard pass followed by mount counts for 7 [seven] points).

3.9 In the case of the mount, when there is a transition straight from back mount to mount or Vice-versa—for being distinct positions—athletes shall be awarded four points for the first mount and another four points for the subsequent mount, so long as the three-second stabilization period was achieved in each position.

NOTES

4 POINT-SCORING POSITIONS*

4.1 Takedown (2 points)



- When an athlete forces his/her opponent back-down or sideways on the ground after having had two feet on the ground at some point during the movement.



- When an athlete forces his/her opponent to the ground in seated position, points will only be awarded once the athlete performing the takedown has maintained the opponent on the ground for 3 (three) seconds.

- When an athlete forces his/her opponent to the ground on all fours or belly-down, points shall only be awarded once the athlete performing the takedown has established a back clinch on his/her opponent—hooks need not be in place but at least one of the opponent's knees must be maintained on the ground for 3 (three) seconds.

- When an athlete forces his/her opponent to the ground in the outlying safety area, points shall only be awarded if the takedown movement began while the athlete performing the takedown had both feet within the match area. In this case, if the athletes land in a stabilized position, the match shall be restarted at the center of the match area in the same position as when the match was stopped.
- When the opponent has one or two knees on the ground, the athlete performing the takedown will only be awarded points if he/she is standing at the moment the takedown is carried out, except under circumstances addressed in item 3.4.
- When the athlete forces his/her opponent to the ground using a single- or double-leg takedown and the opponent lands seated and successfully applies a counter-takedown (another takedown), only the athlete performing the counter-takedown shall be awarded the two points.
- For any takedown technique where the athlete delivering his/her opponent back-down or sideways on the ground lands in guard or half-guard and immediately suffers a successful sweep by the opponent, he/she shall be awarded the two points relating to the takedown and the opponent shall be awarded the two points from the sweep.
- Athletes who initiate a takedown movement after the opponent has pulled guard shall not be awarded the two points or advantage point relating to the move.

4.2 Guard Pass (3 points)

- When the athlete in top position manages to surmount the legs of the opponent in bottom position (pass guard or half-guard) and maintain side-control or north-south position over him/her for 3 (three) seconds.



SIDE-CONTROL



NORTH-SOUTH CONTROL

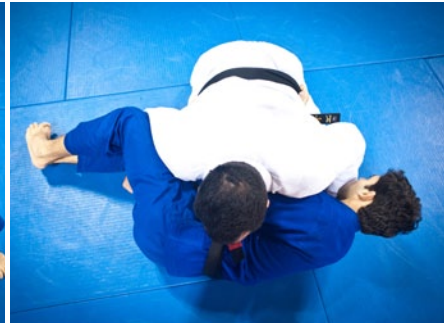

OPPONENT LYING ON HIS SIDE

Note 1: Guard is defined by the use of one or more legs to block the opponent from reaching side-control or north-south position over the athlete on bottom.

Note 2: Half-guard is the guard where the athlete on bottom is lying on his/her back or side and has one of the top-positioned athlete's legs trapped, blocking him/her from achieving side- or north-south control over the bottom-positioned athlete for 3 (three) seconds.

Note 3: The position of the top athlete's legs determines whether it is half-guard or reverse half-guard, according to the following examples:



EXAMPLE 1: In half-guard with his right leg trapped, his left leg is positioned alongside the right leg of the opponent playing guard.



EXAMPLE 2: In reverse half-guard with his right leg trapped, his left leg is positioned alongside the left leg of the athlete playing guard.

4.3 Knee on Belly (2 points)

- When the athlete on top maintaining side-control places a knee on the belly, chest or ribs of his/her opponent – who is on bottom with their back or side on the ground –, maintaining his/her other leg extended diagonally away from the opponent and his/her foot (not knee) on the ground, body facing the opponent's head (not legs), and thus remains for 3 (three) seconds.



4.4 Mount and Reverse Mount (4 points)

- When the athlete is on top, clear of the half-guard, sitting on the opponent's torso and with two knees or one foot and one knee on the ground, facing the opponent's head and with up to one arm trapped under his/her leg – and thus remains for 3 (three) seconds.

Points awarded:

TYPICAL MOUNTED POSITION



MOUNTED POSITION WITHOUT THE FEET TOUCHING THE MATS OR GROUND



SIDEWAYS MOUNTED POSITION



MOUNTED POSITION OVER ONE ARM



REVERSE MOUNT



TECHNICAL MOUNTED POSITION

No points awarded:



MOUNTED POSITION OVER BOTH ARMS



BACKWARDS MOUNTED POSITION

- Should the athlete have one of the opponent's arms trapped under his/her leg, he/she shall only be awarded points for the mount if the leg trapping the arm does not extend beyond the opponent's shoulder.
- When the athlete lands on top with a triangle fastened around the opponent on bottom, no points shall be awarded for the mount.

4.5 Back Control (4 points)

- When the athlete takes control of the opponent's back, placing his/her heels between the opponent's thighs without crossing his/her legs and in a position to trap up to one of the opponent's arms – and thus remains for 3 (three) seconds.

Points awarded:



TYPICAL BACK CONTROL



BACK CONTROL WITH ONE ARM TRAPPED

No points awarded:

BACK CONTROL WITH LEGS IN FIGURE-FOUR TRIANGLE



BACK CONTROL WITH FEET CROSSED



BACK CONTROL WITH BOTH ARMS TRAPPED

4.6 Sweep (2 points)

- When the athlete on bottom with the opponent in his/her guard or half-guard inverts the position, forcing the opponent who was on top to be on bottom – and maintains him/her in this position for 3 (three) seconds.



- When the athlete on bottom with the opponent in his/her guard or half-guard inverts the position and the opponent turns his/her back on all fours and the athlete who initiated the reversal establishes a back clinch over opponent's back – without needing to place hooks but maintaining the opponent with at least one knee on the ground for 3 (three) seconds.



- When the athlete on bottom with the opponent in his/her guard or half-guard gets to his/her feet and maintains the grips necessary to hold the opponent in bottom position for 3 (three) seconds.

** The examples above are merely illustrative and do not represent the full array of situations that may warrant points in each combat situation.*

NOTES

5 ARTICLE 5 – ADVANTAGES

- 5.1** An advantage-point is counted when an athlete achieves a point-scoring pass position requiring 3 (three) seconds of control but is unable to maintain control for the entire duration.
- 5.2** An advantage is counted when the move to a point-scoring pass position is incomplete. The referee should assess whether the opponent was in any real danger and if the athlete clearly came close to reaching the point-scoring pass position.
- 5.3** The athlete shall be awarded an advantage-point when he/she attempts a submission hold where the opponent is in real danger of submitting. Again, it is the referee's duty to assess how close the submission hold came to fruition.



NOT AT REAL RISK

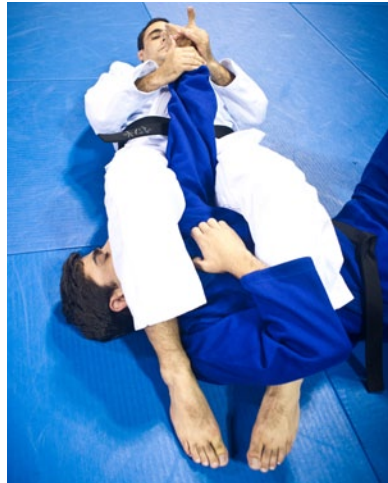

AT REAL RISK

- 5.4** An advantage point may be awarded by the referee even after a match has run its course but before announcing the result.
- 5.5** The referee may only award an advantage point once there is no longer a chance of the athlete reaching a point-scoring position.
- 5.6** An athlete who reaches a point-scoring position but is under attack from a submission hold by his/her opponent shall be awarded an advantage point if he/she does not escape the attack by the end of the match.
- 5.7** Examples of Advantage Points*

5.7.1 Advantage from takedown

- When an athlete achieves a takedown but the opponent does not land back-down or sideways on the ground and returns to his/her feet within 3 (three) seconds.
- When an athlete, in attempting a single-leg takedown, traps one of the opponent's legs and causes the opponent to exit the match area to avoid being taken down and oblige the referee to interrupt the match.

5.7.2 Advantage from Guard Pass

- When an athlete tries to pass guard and the opponent turns on all fours.
- When the athlete achieves half-guard position, with exception to reverse half-guard.
- When both athletes pull guard at the same time, the athlete to achieve top position first is awarded an advantage point.

5.7.3 Advantage from Knee on Belly

- When an athlete places a knee on his/her opponent's belly but only places the knee and not foot of his/her other leg on the ground.

5.7.4 Advantage from the Mount

- When the athlete on top and free of guard or half-guard tries to sit on the opponent's torso and keeps two knees or one foot and one knee on the ground while facing the opponent's head but with both the opponent's arms trapped under his/her legs.

5.7.5 Advantage from Back Mount

- When an athlete mounts his/her opponent's back and places his/her heels between the opponent's thighs but traps both the opponent's arms.
- When an athlete mounts his/her opponent's back but crosses his/her legs, fastens a figure-four around the waist or only places one heel between the opponent's thighs.

5.7.6 Advantage from Sweep

- When, upon clearly causing the opponent to lose his/her balance, an athlete attempts to complete the guard-pass movement and forces the opponent out of the match area.
- When an athlete attempts a sweep from closed guard, takes down the opponent, and opens guard in an attempt to achieve top position but is unable to complete the sweep movement.
- In 50/50 guard, when attempting a sweep, the athlete takes the opponent down and unlocks his/her legs in an attempt to achieve top position but is unable to complete the sweep movement.

** The examples above are merely illustrative and do not represent the full array of situations that may warrant advantage points.*

5.8 Specific Cases where Advantage Points are not awarded anymore.

5.8.1 Achieving half-guard does not warrant an advantage point for an athlete who was in mounted or side-control position.

5.8.2 Athletes who suffer a takedown from the opponent and manage to roll to top position shall no longer be awarded an advantage point by the referee.

5.8.3 Athletes who begin a sweep movement but deliberately do not seek to complete the movement, in order to retain their defensive position, shall not be awarded an advantage point for the sweep.

NOTES

6 ARTICLE 6 – PENALTIES

6.1 Penalties are technical or disciplinary infractions addressed in the rules that are committed by athletes before, during or after a match.

6.2 Penalty Classification

6.2.1 Severe Penalty

6.2.2 Serious Penalty

6.2.3 Minor Penalty

6.2.4 Combativeness Penalty (Stalling)

6.3 Severe Penalty

6.3.1 Subdivided into technical penalties and disciplinary penalties.

6.3.2 Technical Penalties*.

- When an athlete's gi is rendered unusable and he/she is unable to exchange it for a new one within a period of time stipulated by the referee.
- When an athlete deliberately flees the match area to avoid submitting to a submission hold applied by his/her opponent.
- When an athlete is not wearing an undergarment under his/her gi and this fact comes to the referee's attention.
- In the Jiu-Jitsu No-Gi, when an athlete applies creams, oils, gels or any slippery substance to any part of the body.
- When an athlete applies a hold prohibited for his/her respective division, as indicated in the table below.

	4 to 12 years of age	13 to 15 years of age	16 & 17 years and adult white belt	Adult to Senior 5 blue & purple belts	Adult to Senior 5 brown & black belts	
1	●	●	●	●	●	Slam
2	●	●				Choke with spinal lock
3	●	●	●	●	●	Spinal lock without choke
4	●	●	●	●		Bicep slicer
5	●	●	●	●	●	Heel hook
6	●	●	●	●		Calf slicer
7	●	●	●			Lock inside the closed guard with legs compressing kidneys or ribs
8	●	●	●	●	●	Locks twisting the knees.
9	●	●	●	●	●	Crossing outside foot inwards across opponent's crotch (straight foot lock, X-guard and 50-50 guard)
10	●	●	●	●		Knee bar
11	●	●				Straight foot lock
12	●	●	●	●	●	In straight foot lock, turning in the direction of foot not under attack.
13	●	●				Forearm choke using the sleeve (Ezequiel choke)
14	●	●				Frontal guillotine choke
15	●	●	●	●	●	Kanibasami (scissor)
16	●	●	●			Wrist lock
17	●	●	●			Mount naked choke
18	●	●	●	●		Toe hold
19	●	●	●	●	●	In toe hold, applying outward pressure on the foot
20	●	●				Omoplata
21	●	●	●	●	●	Bending fingers backwards
22	●	●				Triangle (pulling head)
23	●					Submission techniques stretching legs apart
24	●	●				Arm triangle

6.3.2 TECHNICAL PENALTIES

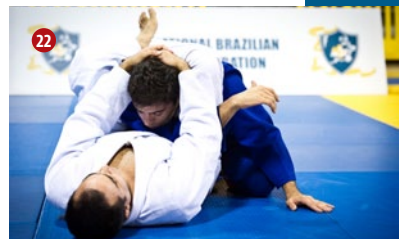
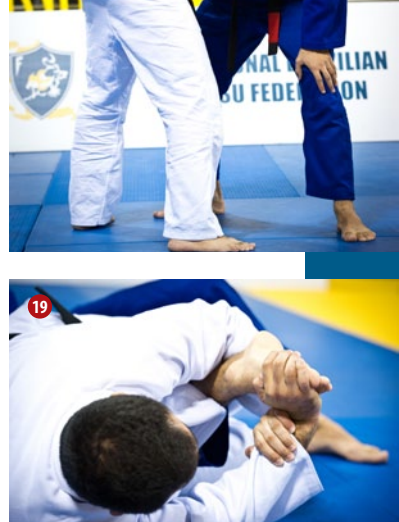
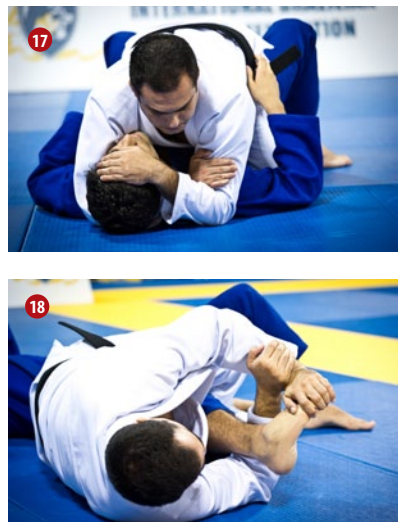
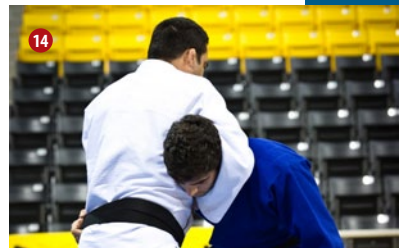
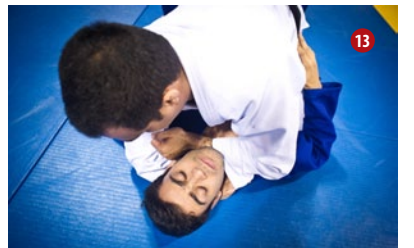
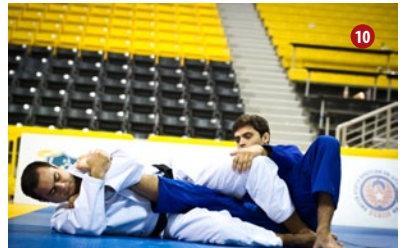
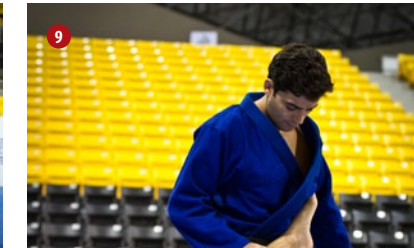

6.3.2 TECHNICAL PENALTIES



** The images shown on the list are examples of prohibited techniques and do not represent the full array of prohibited technical situations and variations.*

6.3.3 Disciplinary Penalties

- When an athlete directs profane language or obscene gestures at his/her opponent, the center table, table officials, referee or public.
- When an athlete exhibits hostile behavior towards an opponent, referee or any other member of the organizing committee or public.
- When an athlete bites, pulls hair, strikes or applies pressure to the genitals or eyes, or intentionally uses a traumatic blow of any kind (such as punches, elbows, knees, head butts, kicks, etc).
- When an athlete exhibits offensive or disrespectful behavior towards an opponent or the public through words or gestures during a match or in celebrating victory.

6.4 Serious Penalties

- 6.4.1 When an athlete kneels or sits without having a grip of any kind on the opponent.
- 6.4.2 When a standing athlete flees the bounds of the match area, avoiding combat with the opponent
- 6.4.3 When a standing athlete pushes his/her opponent to outside the match area without clear intent of attempting a submission or scoring. (**Note:** previously, the athlete being pushed was the one penalized).
- 6.4.4 When an athlete on the ground evades combat by sliding his/herself outside the match area.
- 6.4.5 When an athlete on the ground stands to escape combat and does not return to combat on the ground.
- 6.4.6 When an athlete breaks the grip of the opponent pulling guard and does not return to combat on the ground.
- 6.4.7 When an athlete intentionally removes his/her own gi or belt, causing the match to be stopped.
- 6.4.8 When an athlete grabs the opening of the opponent's sleeve or pant leg with the fingers placed inside the garment, even if performing a sweep or any other maneuver.
- 6.4.9 When an athlete grabs the inside of the opponent's gi top or pants, and when an athlete passes a hand through the inside of the opponent's gi to grip the external part of the gi.
- 6.4.10 When an athlete disobeys a referee order.
- 6.4.11 When an athlete exits the match area following a match prior to the referee announcing the result.*
** For these specific cases there is no gesture for penalization and the referee will signal one penalty be added on the scoreboard for the perpetrating athlete and concede at least one advantage point to the opponent, in accordance with the series of penalties addressed in item 7.3.*
- 6.4.12 When an athlete deliberately exits the match area to prevent the opponent from completing a sweep.**
*** In this case and only this case, the referee should signal two points be awarded to the opponent and one penalty point be added to the score of the athlete who exited the match area.*

6.4.13 For Jiu-Jitsu No-Gi, when an athlete grabs hold of his/her uniform or that of his/her opponent in any way

6.5 Minor Penalties

- 6.5.1** When an athlete places a hand or foot on his/her opponent's face.
- 6.5.2** When an athlete intentionally places his/her foot in his/her opponent's belt.
- 6.5.3** When an athlete intentionally places a foot on the opponent's lapel without gripping the same side of the lapel with his/her hand.
- 6.5.4** When an athlete places a foot in the lapel behind the opponent's neck, with or without gripping it.
- 6.5.5** When an athlete uses his/her own belt or the opponent's belt to assist in a choke or any other circumstance in a match while the belt is untied.
- 6.5.6** When an athlete, without using the gi, strangles his/her opponent using both hands, or applies pressure to the opponent's windpipe using the thumb.
- 6.5.7** When an athlete holds the neck using both hands (one in front and one behind).
- 6.5.8** When an athlete blocks the passage of air to his/her opponent's nose or mouth using his/her hands.
- 6.5.9** When an athlete takes more than 20 seconds to tie his/her belt during a match stoppage.
- 6.5.10** When an athlete speaks to the referee during a match.
- 6.5.11** When an athlete runs around the match area and does not engage in the combat

6.6 Lack of Combativeness (stalling)

- 6.6.1** Lack of combativeness (stalling) is defined by one athlete clearly not pursuing positional progression in a match and also when an athlete impedes his/her opponent from carrying out said progression.
- 6.6.2** When both athletes simultaneously demonstrate a lack of combativeness (stalling) in any position in a match.
- 6.6.3** Lack of combativeness (stalling) is not declared when an athlete is defending his/herself from an opponent's attacks from mount, back-control, side-control or north-south positions.
- 6.6.4** Examples of situations constituting lack of combativeness (stalling)*:

- When an athlete, upon achieving side-control or north-south positions over an opponent, does not seek positional progression.
- When an athlete in an opponent's closed guard does not seek to pass guard and at the same time prevents the opponent from seeking positional progression from guard.
- When the bottom athlete playing closed guard wraps his/her arms around the opponent's back or performs any other controlling movement clutching the opponent to him/her without intending to achieve a submission or score.
- When an athlete on foot grabs and maintains his/her hand on the opponent's belt, preventing the opponent from completing a takedown movement and without attempting an attack of any kind.

** The aforementioned examples are merely illustrative and do not represent all the situations that may be deemed lack of combativeness (stalling).*

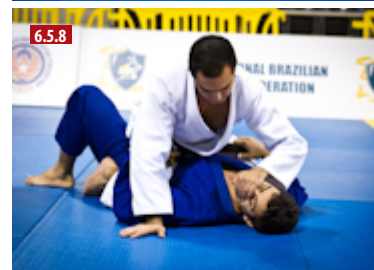

7 ARTICLE 7 – PENALTIES

7.1 Penalties are awarded by referees with the aim of assuring the match flows properly and that the rules of the sport and the competition are being respected.

7.1.1 Referees shall abide by the following series of penalties for each category of penalty.

7.2 Severe Penalties

7.2.1 Technical Penalties: Summary disqualification from the match at the moment of the infraction.

7.2.2 Disciplinary Penalties: Summary disqualification from the match and competition at the moment of the infraction.

7.3 Serious Penalties

7.3.1 Referees shall abide by the following series of penalties.

- 1st penalty – Gestured warning.
- 2nd penalty – Advantage point concession to opponent of penalized athlete and first penalty marked on scoreboard for perpetrating athlete.
- 3rd penalty – Two-point concession to opponent of penalized athlete and second penalty marked on scoreboard for perpetrating athlete.
- 4th penalty – Disqualification of perpetrating athlete.*

7.3.2 Serious penalties are cumulative between them and different infractions will bring into effect the escalating penalty sequence addressed in clause 7.3.1.

** In the under-15-year-old divisions, on an athlete's fourth and fifth penalties the referee shall award two points to the opponent and one penalty point to the perpetrating athlete for each penalty. Only on the sixth penalty shall the referee disqualify the perpetrating athlete.*

7.4 Minor Penalties

7.4.1 Referees shall abide by the following sequence of penalties.

- 1st Penalty – Gestured warning.
- 2nd Penalty – Advantage point awarded to opponent and first penalty point marked on scoreboard for perpetrating athlete.
- 3rd Penalty – Two points awarded to penalized athlete's opponent and second penalty point marked on scoreboard for athlete.
- 4th Penalty – Disqualification of perpetrating athlete.*

7.4.2 Minor penalties are not cumulative between them and only infractions of the same kind will effectuate the escalating penalty sequence addressed in clause 7.4.1.

** In the under-15-year-old division, on an athlete's fourth and fifth penalties the referee shall award two points to the opponent and one penalty point to the perpetrating athlete for each penalty incurred. Only on the sixth penalty shall the referee disqualify the athlete.*

7.5 Penalties for lack of combativeness

7.5.1 Penalties for lack of combativeness are covered by special criteria.

- The first penalty for lack of combativeness is always a gestured and verbal warning (“Lute”), regardless of the number of penalties the referee has signaled be marked on the scoreboard beforehand.
- Starting with the second penalty for lack of combativeness – to determine which penalty the perpetrating athlete shall be awarded –, referees should follow penalty guidelines described in item 7.3, and the athlete shall be penalized by awarding an advantage point or two points to his/her opponent or by disqualification, according to the penalty count on the scoreboard.

7.5.2 Penalties for lack of combativeness shall adhere to the following sequence once the referee has considered one or both athletes to have incurred the situations described in item 6.6.

- 1st – The referee shall count out 20 (twenty) seconds.
- 2nd – The referee shall preform the gesture signifying the First warning for lack of combativeness (in accordance with the table in item 1.4.1) and issue the verbal command “LUTE”.
- 3rd – Starting with the second penalty for lack of combativeness, following the 20- (twenty-) second count and verbal command “LUTE”, the referee shall gesture for the perpetrating athlete to be awarded the penalty, as described in item 7.3.1.

NOTES

8 ARTICLE 8 – OBLIGATIONS, BANS, AND DEMANDS

8.1 Gis and uniforms

- 8.1.1** Gis should be tailored using cotton or cotton-like fabric. The fabric should not be so thick or hard as to impede an opponent from gripping it. For juvenile, adult, master and senior divisions, a gi fashioned from woven fabric is mandatory.
- 8.1.2** Gis must be of uniform color, of which the following are permissible: white, royal blue or black. Gis where the tops and pants are of different colors are not permitted; nor are gis where the collar is of a different color from the rest of the top. Use of a shirt under the gi top is prohibited (except for women).
- 8.1.3** In the men's black belt and women's brown/black belt divisions, the event's organizers may demand that athletes have two gis of different colors (one royal blue and the other white), in order to distinguish between the two athletes in a match.
- 8.1.4** Gis may not exhibit mending or tears, be wet or dirty or emanate unpleasant odors.
- 8.1.5** The gi top should reach the athlete's thigh and the sleeves should come to no more than 5 cm from the athlete's wrist when the arm is extended straight parallel to the ground.
- 8.1.6** Gi pants should reach no more than 5 cm above the tibial malleolus (ankle bone). Wearing pants of any kind under gi pants is prohibited.
- 8.1.7** Athletes should use a durable, 4- to 5-cm-wide belt colored according to the athlete's rank, with a black tip – except for black belts, where the tip should be white or red. The belt should be worn over the top, wrap around the waist twice, and be tied using a double knot tight enough to hold the gi top closed. Once tied in a double knot, each end of the belt should hang 20 to 30 cm in length.
- 8.1.8** Painted gis are forbidden, unless the paint is designed in the form of an academy or sponsor logo – and only on regions of the gi where patches are permitted. Even in cases where they are permitted, the athlete will be obliged to change gis should the paint mark the gi of the opponent.
- 8.1.9** Prior to weighing in, an official gi inspector will check to make sure gi measurements comply with the official measurements stipulated by the IBJJF.
- The inspection will verify whether the following official maximum measurements are met: gi top thickness (1.5 cm), width of gi collar (5 cm), opening of sleeve at full extension (7 cm).
 - Athletes have the right to 2 (two) follow-up gi-measurement inspections, should they fail to pass the first inspection.
 - The gi-measurement inspector will also verify the overall state of the athlete's belt.
- 8.1.10** The measuring stick used will be of the regulation measurements below:
- Total length of measuring stick: 15.0 cm
 - Measuring stick width: 3.5 cm
 - Gi lapel width: 5.0 cm
 - Gi lapel thickness: 1.5 cm
 - Gi sleeve opening at full extension: 7.0 cm

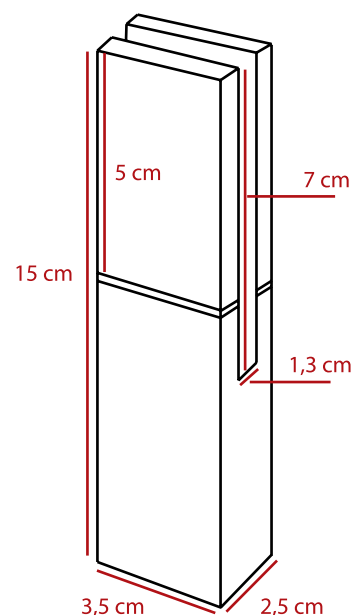

8.1.11 After weighing in, athletes may not change their gis for their first match, under penalty of disqualification.

- Following the first match, athletes may request of the Ring Coordinator permission to change gis. The new gi will undergo a new measurement inspection.
- Athletes will be subject to disqualification should they not undergo a measurement inspection of their new gi prior to the first match wearing the new gi.

8.1.12 For Jiu-Jitsu No-Gi, athletes should abide by the following attire requirements:

• **Men:**

Board shorts primarily black with up to 30% of their rank color (belt), with no pockets or with pockets entirely stitched shut, and reaching at least halfway down the thigh and at most to the knee. Attached metal or plastic of any kind that may hurt the opponent is expressly forbidden on the board shorts.

Men are permitted the use of shorts or trunks of elastic fabric (clings to body), so long as they are worn under the regulation shorts.

Shirt of elastic fabric (clings to body) at a length that covers the shorts' waist band, of black or white color, and displaying at least 10% of the color of the rank (belt) to which the athlete belongs. Shirts that are 100% the color of the rank (belt) the athlete belongs to are also acceptable.

• **Women:**

Board shorts or lycra elastic pants primarily black with up to 30% of their rank color (belt), without pockets or with pockets entirely stitched shut, and reaching at least halfway down the thigh and at most to the knee. Attached metal or plastic of any kind that may hurt the opponent is expressly forbidden on the board shorts.

Shirt of elastic fabric (clings to body) at a length that covers the shorts' waist band, of black or white color, and displaying at least 10% of the color of the rank (belt) to which the athlete belongs. Shirts that are 100% the color of the rank (belt) the athlete belongs to are also acceptable.

8.2 Hygiene

8.2.1 Athletes' finger and toe nails should be trimmed and short.

8.2.2 Long hair should be tied up so as not to cause opponents any discomfort.

8.2.3 Athletes will be disqualified if they are wearing hair dye that stains their opponents' gi during a match.

8.2.4 Athletes should use footwear up to the match area and wherever their use is permitted.

8.2.5 Following weigh in, the Gi Inspector should check athletes for any skin conditions.

- Athletes presenting skin lesions noticed by the inspector shall be directed to the event's medical area.
- Athletes should present a statement from a doctor declaring the lesion not contagious and not harmful to other competitors.
- For the organizers of the event, the tournament medic has the final say on whether to allow an athlete to compete or not.

8.3 Further Requirements

- 8.3.1 Each athlete shall only mount the official scale of the event to have his/her weight taken once.
- 8.3.2 Athletes are allowed to weigh in without knee or elbow braces, but they will have to be wearing them at the time of the gi inspection.
- 8.3.3 Patches may only be affixed in authorized regions of the gi, as depicted in the illustrations below. They should be of cotton fabric and properly seamed. All patches unseamed or in unauthorized regions of the gi will be removed by the gi inspectors.
- 8.3.4 Permitted: a gi brand tag in the front lower part of the pants (according to illustration). The tag must be made of a thin fabric (not embroidered) and be at most 36 cm².

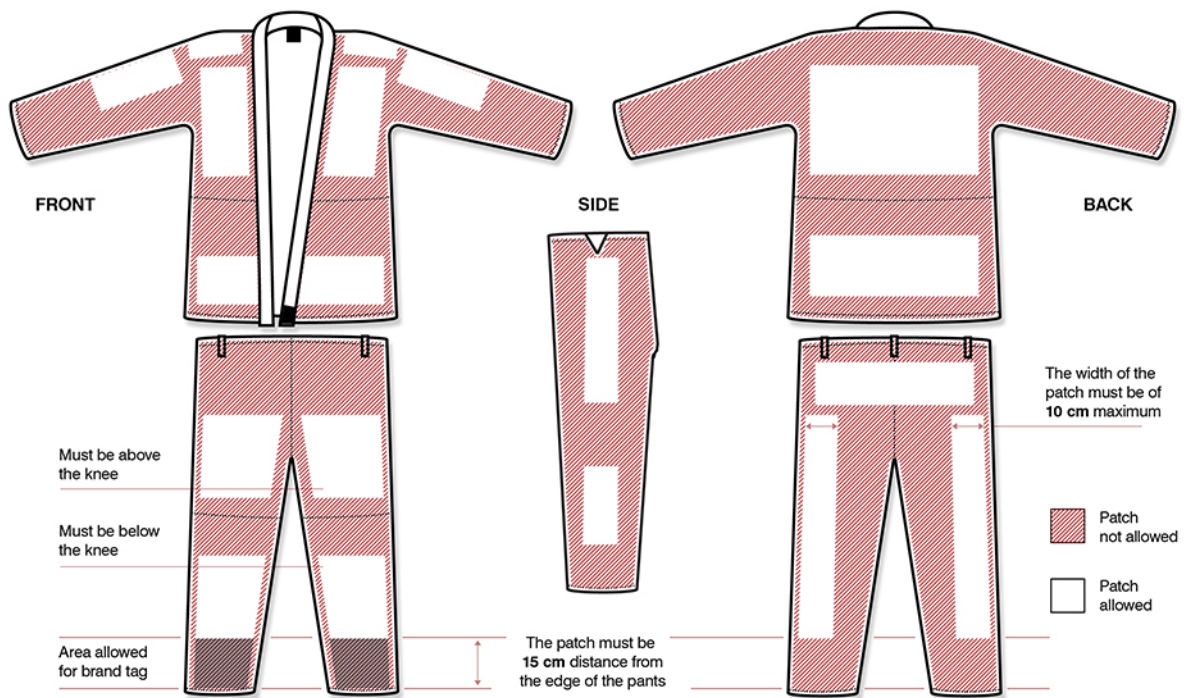

- 8.3.5 Use of any foot gear, head gear, hair pins, jewelry, cups (genital protectors), or any other protector fashioned of hard material that may cause harm to an opponent or the athlete him/herself is forbidden. Also forbidden is the use of head wear – be it bandages, hoods or an elastic cap.
- 8.3.6 The use of joint protectors (knee, elbow braces, etc.) that increase body volume to the point of making it harder for an opponent to grip the gi are also forbidden.
- 8.3.7 In the female division, the use of thong-type undergarments is not permitted; only briefs-type undergarments.

GENERAL COMPETITION GUIDELINES

1 ARTICLE 1 – DIVISIONS AND REGULATION MATCH DURATIONS

- 1.1** The age division to which an athlete belongs is determined by the age the athlete is or will be on the day of a given tournament.
- 1.2** There is no maximum age for the adult, master and senior divisions – only minimum age.
- 1.3** The divisions shall abide by the age limits and regulation match durations described in the table below.

DIVISION	AGE RANGE	REGULATION MATCH DURATION
MIGHTY MITE I	(Current Year) - (Birth Year) = 4	02 minutes
MIGHTY MITE II	(Current Year) - (Birth Year) = 5	02 minutes
MIGHTY MITE III	(Current Year) - (Birth Year) = 6	02 minutes
PEE WEE I	(Current Year) - (Birth Year) = 7	03 minutes
PEE WEE II	(Current Year) - (Birth Year) = 8	03 minutes
PEE WEE III	(Current Year) - (Birth Year) = 9	03 minutes
JUNIOR I	(Current Year) - (Birth Year) = 10	04 minutes
JUNIOR II	(Current Year) - (Birth Year) = 11	04 minutes
JUNIOR III	(Current Year) - (Birth Year) = 12	04 minutes
TEEN I	(Current Year) - (Birth Year) = 13	05 minutes
TEEN II	(Current Year) - (Birth Year) = 14	05 minutes
TEEN III	(Current Year) - (Birth Year) = 15	05 minutes
JUVENILE I	(Current Year) - (Birth Year) = 16	05 minutes
JUVENILE II	(Current Year) - (Birth Year) = 17	05 minutes
ADULT	(Current Year) - (Birth Year) ≥ 18	05 minutes – White 06 minutes – Blue 07 minutes – Purple 08 minutes – Brown 10 minutes – Black
MASTER	(Current Year) - (Birth Year) ≥ 30	05 minutes – White / Blue 06 minutes – Purple / Brown / Black
SENIOR 1	(Current Year) - (Birth Year) ≥ 36	05 minutes
SENIOR 2	(Current Year) - (Birth Year) ≥ 41	05 minutes
SENIOR 3	(Current Year) - (Birth Year) ≥ 46	05 minutes
SENIOR 4	(Current Year) - (Birth Year) ≥ 51	05 minutes
SENIOR 5	(Current Year) - (Birth Year) ≥ 56	05 minutes

- 1.4** Minimum between-match rest time is described in the table below:

MATCHES UP TO SEMIFINALS	Equal to regulation match duration for respective division
FINAL MATCHES	Double regulation match time for respective division

2 ARTICLE 2 – BRACKETS

2.1 The athletes in each division shall be sorted into brackets.

2.2 The brackets will serve as a simple elimination system, where the losing athlete from each match is eliminated and the winner goes through to the next stage of the brackets.

2.3 The only exception to the simple elimination system is when there is a bracket of three (only three athletes make up the bracket).

2.3.1 In a bracket of three, the winner of the first match goes through to the final and the losing athlete faces the third competitor in the bracket. The athlete who wins the second match – regardless of whether it is the same athlete to lose the first match – goes through to the final to face the winner of the first match.

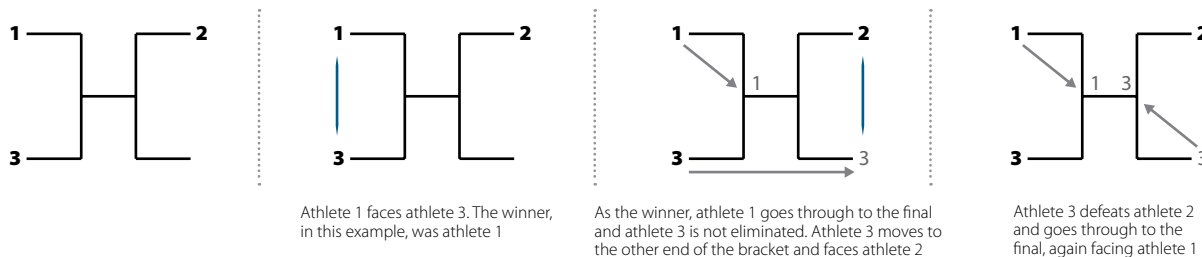

2.4 Disqualification in semifinals and final

2.4.1 Semifinals

- When both athletes in a semifinal match are disqualified via technical penalty, the other semifinal shall count as the division final. In this case, the disqualified athletes shall be proclaimed the third-place athletes.
- When both athletes in a semifinal match are disqualified via disciplinary penalty, the other semifinal shall count as the division final. In this case, the disqualified athletes shall not be proclaimed the third-place athletes, thus leaving the post vacant.
- When all four athletes in both division semifinals are disqualified via technical penalty, the four athletes who lost to them in the quarterfinals shall compete against each other in extra semifinal matches to determine the divisional finalists. In this case, all four athletes disqualified in the semifinals shall be proclaimed third-place winners – and the athletes who lost the extra semifinals shall not receive medals.
- When all four athletes in both division semifinals are disqualified via disciplinary penalty, the four athletes who lost to them in the quarterfinals shall compete against each other in extra semifinal matches to determine the divisional finalists. In this case, the disqualified semifinalists shall not receive medals – and the athletes who lost the extra semifinals shall be proclaimed third-place winners.

2.4.2 Finals

- When both athletes in a final match are disqualified via technical penalty, the athletes who lost the semifinals shall return to dispute the final. In this case, the disqualified athletes shall be proclaimed third-place winners.
- When both athletes in a final match are disqualified via disciplinary penalty, the athletes who lost the semifinals shall return to dispute the final. In this case, the disqualified athletes shall not be proclaimed third-place winners, leaving that post vacant.

3 ARTICLE 3 – INTER-ACADEMY CONTESTS

3.1 The results of the three top-placing athletes shall count for points in the overall inter-academy contest for each division of the competition.

3.2 The following points are awarded for each of the top three placements:

- **Champion** – 9 points
- **Runner-up** – 3 points
- **Third place** – 1 point

3.3 Tie-Breaker

3.3.1 Tie-breakers at championships where points from each age category are counted separately.

- The academy with the greatest number of gold medals shall be declared the winner.
- In the event of a draw in the number of champions, the academy with the greatest number of silver medalists shall be declared the winner.
- In the event of a draw in the number of gold and silver medalists, the academy with the greatest number of highest-ranking champions shall be declared the winner.
- In the event of a draw in the number of highest-ranking champions, the academy with the highest-ranking and heaviest champion shall be declared the winner.
- In the event of a draw in all the aforementioned scenarios, the winner shall be determined at random.

3.3.2 Tie-breaker at championships where points from two or more age divisions are counted as a whole.

- The academy with the greatest number of gold medalists shall be declared the winner.
- In the event of a draw in the number of champions, the academy with the greatest number of silver medalists shall be declared the winner.
- In the event of a draw in the number of gold and silver medalists, the academy to be declared winner will have the greatest number of black belt champions in the following age divisions in the following sequence: adult, master, senior 1, senior 2, senior 3, senior 4, senior 5.
- In the event of a draw in the number of black belt champions across all age divisions, the academy to be declared the winner will have the greatest number of champions at the highest belt rank in the age divisions in the following sequence: adult, master, senior I, senior II, senior III, senior IV, senior V, juvenile II, juvenile I, teen III, teen II, teen I, junior III, junior II, junior I, pee wee III, pee wee II, pee wee I, mighty mite III, mighty mite II, mighty mite I.
- In the event of a draw in all the aforementioned divisions, the winner shall be determined by random pick.

3.4 Points from divisions where only one athlete signed up shall not count in the inter-academy contest.

3.5 Points from divisions where only two athletes from same academy signed up shall not count in the inter-academy contest.

3.6 A WO (no show) of an athlete for his/her match shall not alter the previously existing bracket structure, nor the point count for the respective bracket.

Ex: Should an athlete WO (no show) or be disqualified in a bracket with four athletes, the bracket shall not be reconfigured to a bracket of three format (item 2.3.1)

3.7 Team contest

3.7.1 Should there be a draw in team scores after all the matches are over, the tied teams may pick one athlete each to compete in a decisive extra match.

4 ARTICLE 4 – PRIZES

4.1 The three top-placed athletes in each division shall receive medals on the championship's official winners' podium.

4.1.1 For all championships, the awards shall adhere to the following norms:

- The champion shall receive a gold medal.

- The runner-up shall receive a silver medal.
- The two third-place athletes shall receive one bronze medal apiece.
- The prizes shall be awarded according to the results proclaimed by the referees. Exchanging placement at the moment prizes are awarded is expressly forbidden.
- To participate in the awards ceremony, the athlete should be wearing exclusively a gi permitted for use in the Gi tournament or the official uniform of the Jiu-Jitsu No-Gi tournament.
- Accessories foreign to the practice of the sport are prohibited.

4.1.2 For team contests, only the top two teams shall be awarded medals on the championship's official winners' podium.

4.2 Athletes disqualified by WO (no show) shall not be awarded a medal and their names will not appear on the championship's final placement list.

4.2.1 The only exception to the stipulation in item 4.2 is when an athlete has competed in at least one match in the division in question.

4.2.2 Athletes disqualified via disciplinary penalty shall not receive a medal and their names shall not appear on the championship's final placement list.

4.3 Athletes alone in a division will need to undergo the gi inspection, weigh in and be approved, in order to receive a medal and have his/her name appear on the championship's final placement list.

4.3.1 In the ultra heavyweight and absolute divisions, athletes alone in a division will need to undergo the gi inspection and be approved, in order to receive a medal and have his/her name appear on the championship's final placement list.

5 ARTICLE 5 – REGISTRATION

5.1 Athletes registering for any championship must be affiliated with an academy, and that academy is subject to IBJJF approval.

5.2 Each academy has the right to register two athletes in each weight/belt/age/gender division.

5.3 The teacher responsible for each academy or association of academies has sovereign power over the registration of the athletes representing his/her academy or association of academies – and is authorized to make changes to the lineup and add or exclude athletes in all divisions, including the absolute.

5.4 Registration for each championship shall adhere to a timetable widely publicized by the IBJJF, and all deadlines must be enforced.

5.5 Athletes known or found to hold a black belt in judo are forbidden from taking part in any championship as a white belt.

5.6 Athletes who do not meet the requirements put forth in championship guidelines or those in this General Competition Regulations Book may be disqualified at any moment prior to, during or following the competition.

6 ARTICLE 6 – FURTHER PROVISIONS

6.1 The published guidelines of each individual championship shall overrule this General Competition Regulations Book when need be.

6.2 It is strictly forbidden for anyone from the organizing committee, performing any official function at a championship, to issue instructions to an athlete in the competition area.

6.3 It is strictly forbidden for anyone not part of the event's organizing committee to speak with the table officials.

NOTES

A large, empty rectangular box with a thin black border, occupying most of the page. It is intended for the user to write their notes.

1 ARTICLE 1 – COMPETITION AREA

1.1 The competition area shall be composed of one or more match areas, score tables, a warm-up area, a weigh-in area, a center table, and an awards area.

1.2 Match Areas

1.2.1 Match areas are composed of a combat area and an outlying safety area distinguished from each other by different colors.

1.2.2 The minimum size of a match area is 64m², with 36m² comprising the combat area and 28m² comprising the safety area surrounding the combat area.

1.2.3 The maximum size of a match area is 100m², with 64m² comprising the combat area and 36m² comprising the safety area surrounding the combat area.

1.2.4 A 64m² match area assembled using 2- by 1-meter segments is to be configured in the following manner:
- 18 segments in the combat area.
- 14 segments in the safety area.

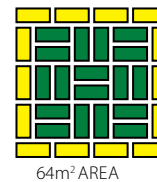

1.2.5 A 100m² match area assembled using 2- by 1-meter segments is to be configured in the following manner:
- 24 segments in the combat area.
- 18 segments in the safety area.

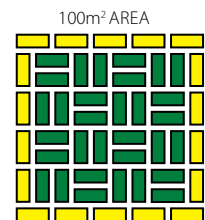

1.3 Score-keeping tables

1.3.1 Shall be composed of one table and one or two chairs, placed in front of each match area.

1.3.2 Each table should clearly display the number of the corresponding match area and contain two scoreboards and one clock. In special cases, an electronic scoreboard may be used in place of the manual scoreboards and clock.

1.3.3 The scoreboard is to be configured as follows:



1.3.4 The manual scoreboard shall be placed on the table in such a way that the green-and-yellow half is on the right of the referee when he/she is in front of the score-keeping table.

1.4 Warm-Up Area

1.4.1 A cordoned-off area adjacent to the competition area, exclusively for athlete use.

1.4.2 The championship organizing committee shall summon the athletes of each division to the warm-up area as pre-determined by the event timetable.

1.4.3 It is at this location and only at this location that Ring Coordinators will direct athletes to the match areas.

1.4.4 It is up to the event organizing committee whether a scale will be provided in the warm-up area for athletes to check their weight prior to the official weigh-in.

1.5 Weigh-in and Gi-Inspection Area

- 1.5.1 Athletes' gis shall undergo an inspection for size, patch placement, hygiene, belt, and overall condition.
- 1.5.2 The weigh-in area should include at least one scale with which to determine athlete weight.

1.6 Center Table

- 1.6.1 To be placed at a location central to all match areas. From there the brackets will be distributed to Ring Coordinators and results diagrams will be drawn up in order to award athletes their medals.

1.7 Podium

- 1.7.1 To be composed of three levels: the highest level for first-place athletes; the second highest, on the right, for second-place athletes; and the lowest, on the left, for third-place athletes.

2 ARTICLE 2 – STAFF AND THEIR DUTIES

2.1 General Director of Competition: oversees the overall competition and makes final decisions regarding any issues pertaining to event organization and progress.

2.2 Ring Coordinator Supervisor: oversees all the work performed by Ring Coordinators, making sure they are properly keeping up with bracket progression. They help the center table to distribute, collect and match brackets.

2.3 General Director of Refereeing: selects referees and rotates them throughout the event. He/she guides and issues a technical evaluation of the referees at the end of each competition day.

2.4 Center Table Coordinator: distributes the brackets, conveys results to the center table, and is responsible for registration control and bracket planning for the absolute division.

2.5 Center Table Assistant: provides assistance to the Center Table Coordinator and records the results from each bracket delivered by the Ring Coordinator.

2.6 Referee: judges each match.

2.7 Ring Coordinator: receives the brackets from the center table, summons the athletes to the warm-up area, checks their IDs, ushers them to the gi measurer, weighs them before first match, directs them to the match area, and following the match records the result in the bracket. After a bracket has come to a close, he/she returns the bracket to the center table.

2.8 Table Official: records the points, advantages and penalties signaled by the referee on the scoreboard, keeps match time, and announces the end of the match using a whistle.

2.9 Gi Inspector: inspects each athlete's gi to be sure they meet the specifications in size, hygiene, appearance, patch positioning and overall condition.

2.10 Awards Team: calls the medalists to the podium and delivers medals to the medalists from each division.

2.11 Announcer: announces the divisions over the loudspeaker and makes miscellaneous announcements throughout the competition.

NOTE: IN CASE OF ANY DOUBT, REFER TO PORTUGUESE VERSION.

NOTES

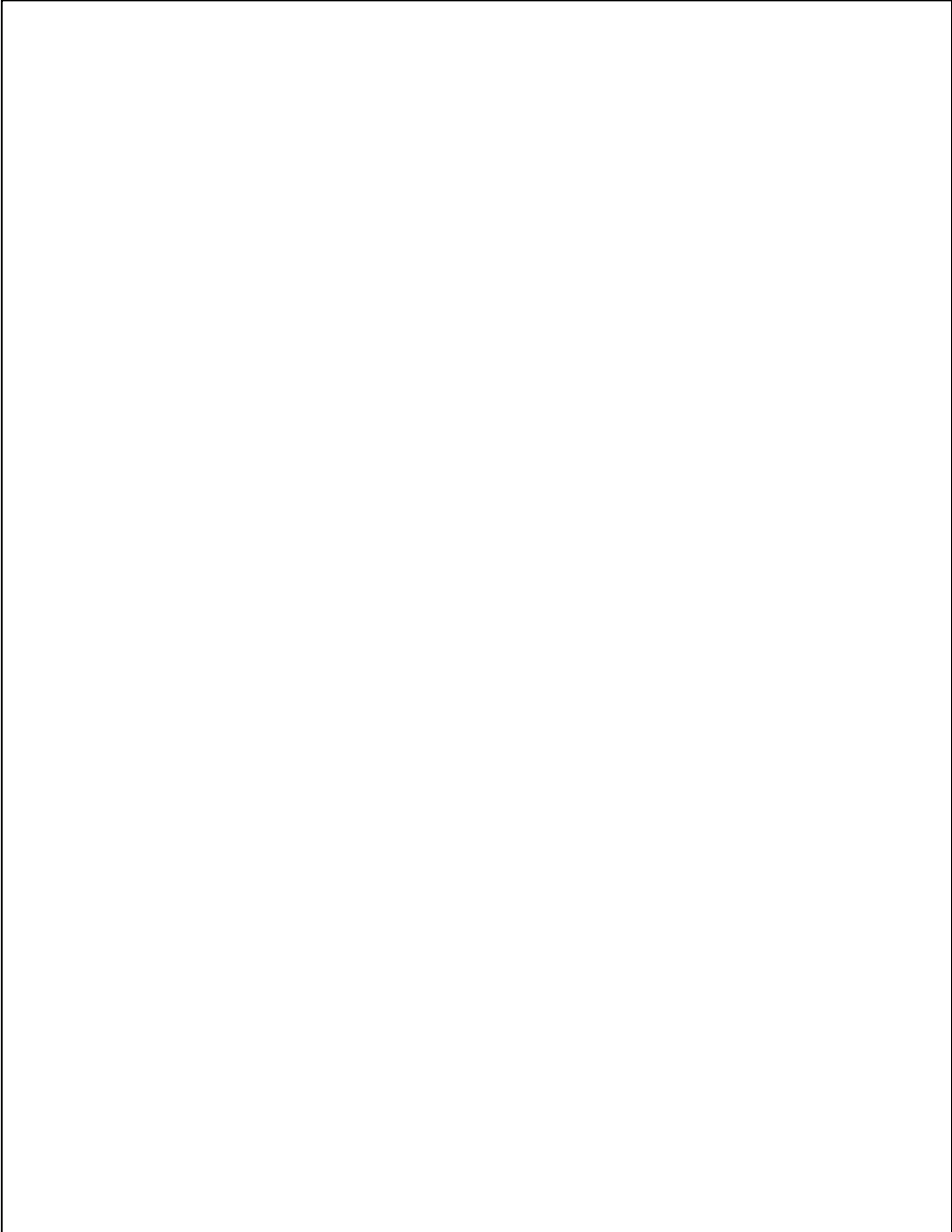

INTERNATIONAL BRAZILIAN JIU-JITSU FEDERATION (IBJJF)

RIO DE JANEIRO, BRAZIL
JANUARY 2012



IBJJF

INTERNATIONAL BRAZILIAN JIU-JITSU FEDERATION

www.ibjff.com

