

**NEUROS AUDIO
RECORDER-3 REV-B**

PAGE 01: INDEX
PAGE 02: DM320 POWER AND GND
PAGE 03: VIDEO ADC
PAGE 04: DM320 VIDEO I/O INTERF
PAGE 05: DM320 GIO
PAGE 06: SDRAM
PAGE 07: NOR FLASH
PAGE 08: DM320 EMIF
PAGE 09: MISC I/O; SD/MS; UART
PAGE 10: CLOCKING; POR; JTAG
PAGE 11: COMPACT FLASH
PAGE 12: ETHERNET 10/100
PAGE 13: AUDIO ADC/DAC
PAGE 14: VIDEO OUT BUFFER
PAGE 15: REMOTE CONTROL
PAGE 16: FULL SPEED USB I/O
PAGE 17: POWER SUPPLY

Title		
Neuros Audio - RECORDER 3		
Size	Document Number	Rev
A4	NEUROS RECORDER-3	B
Date:	Friday, June 30, 2006	Sheet 1 of 17

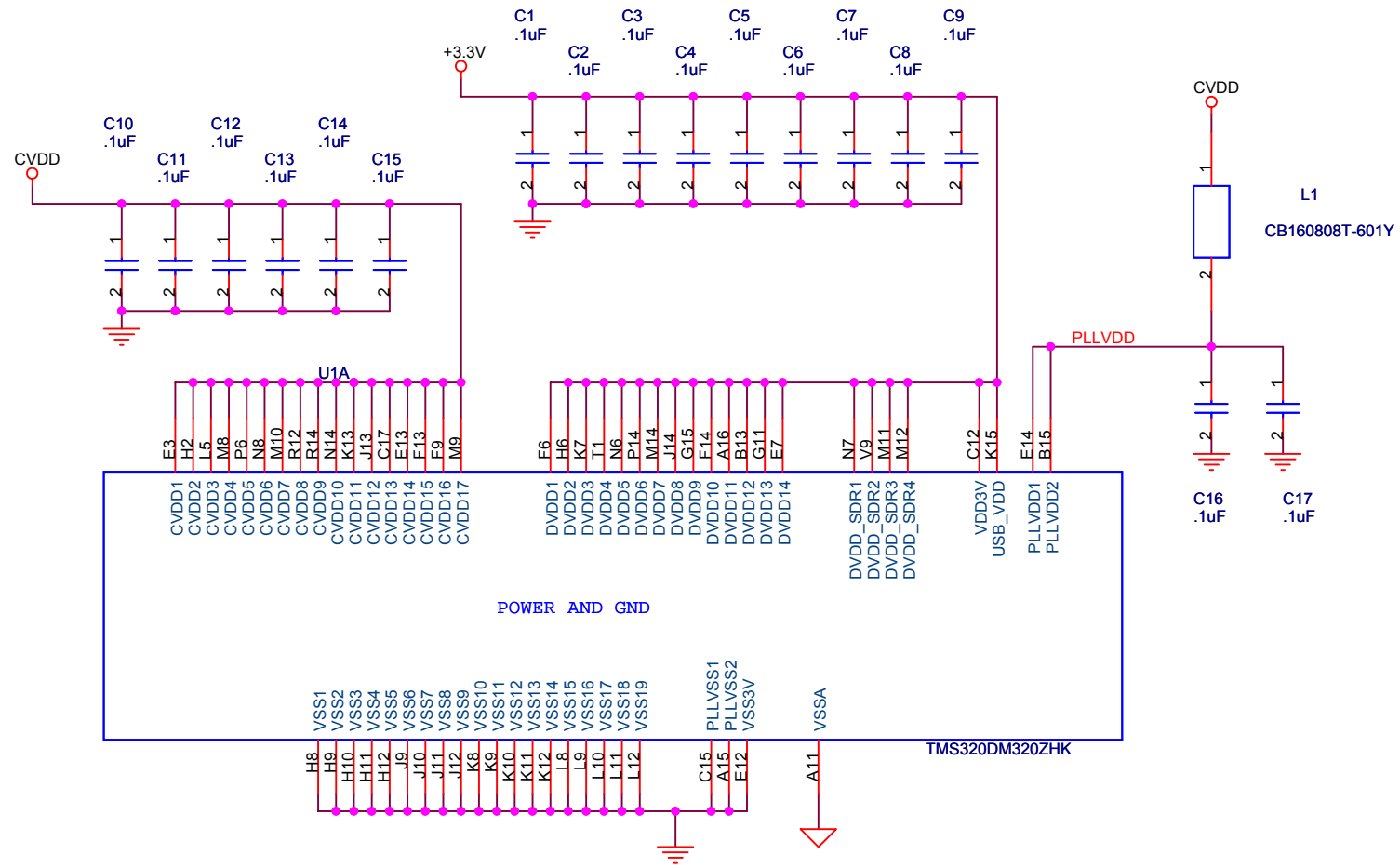

Title		
DM320 POWER AND GND		
Size	Document Number	Rev
A4	NEUROS RECORDER-3	B
Date:	Thursday, July 13, 2006	Sheet 2 of 17

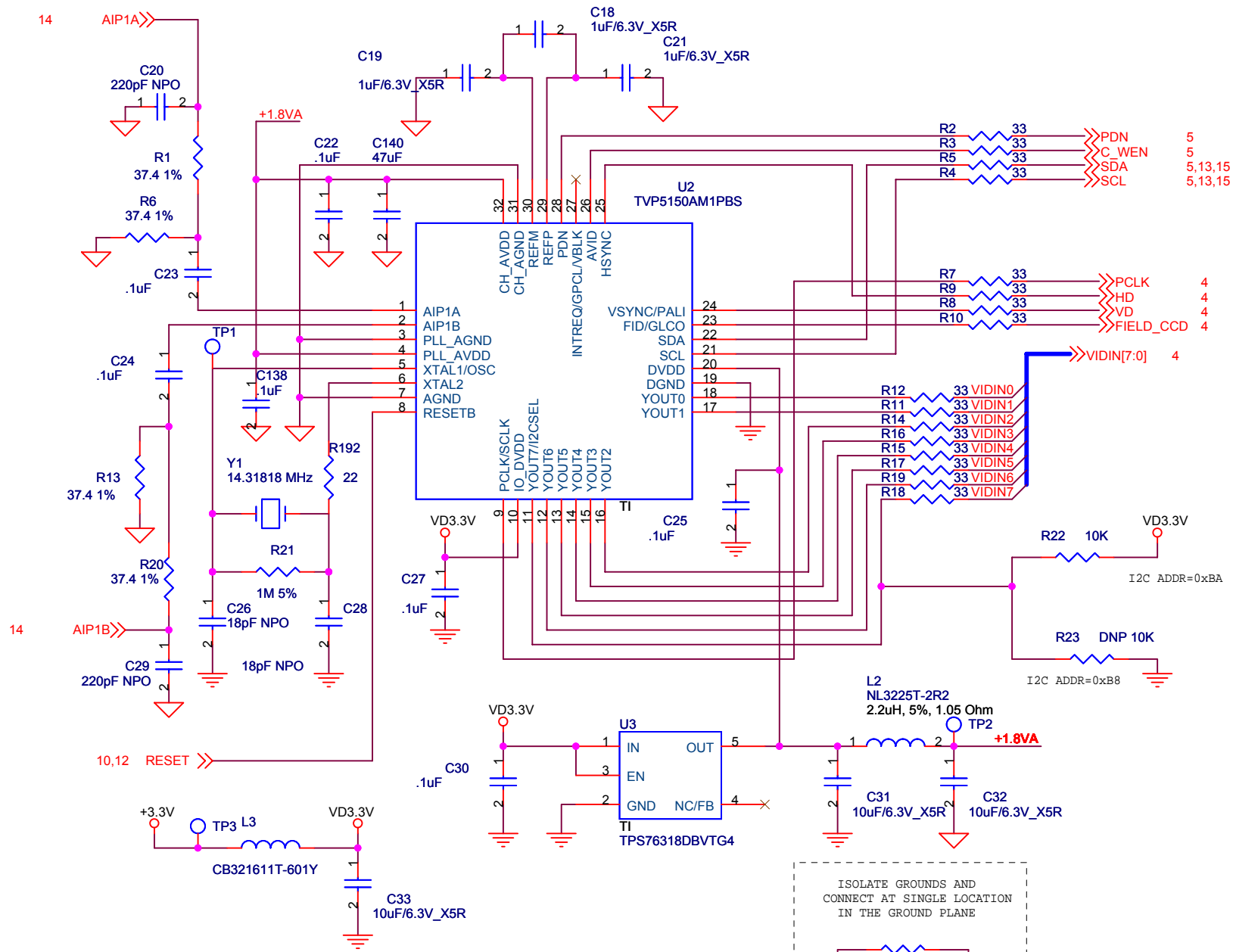

ISOLATE GROUNDS AND
CONNECT AT SINGLE LOCATION
IN THE GROUND PLANE

Title		
VIDEO ADC		
Size	Document Number	Rev
A4	NEUROS RECORDER-3	B
Date:	Thursday, July 13, 2006	Sheet 3 of 17

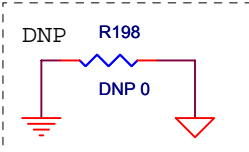
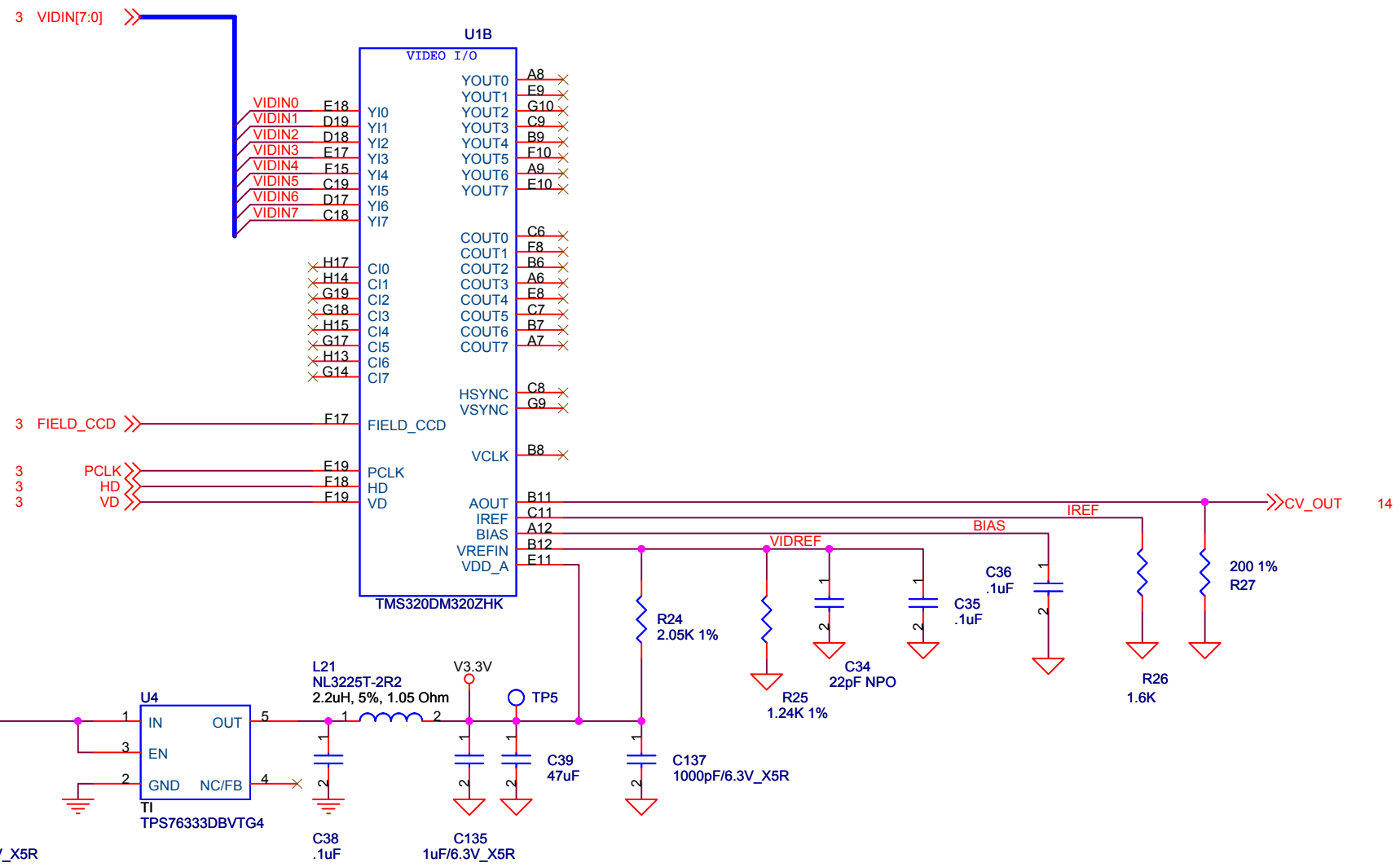

Title		
DM320 VIDEO I/O INTERFACE		
Size	Document Number	Rev
A4	NEUROS RECORDER-3	B
Date:	Thursday, July 13, 2006	Sheet 4 of 17

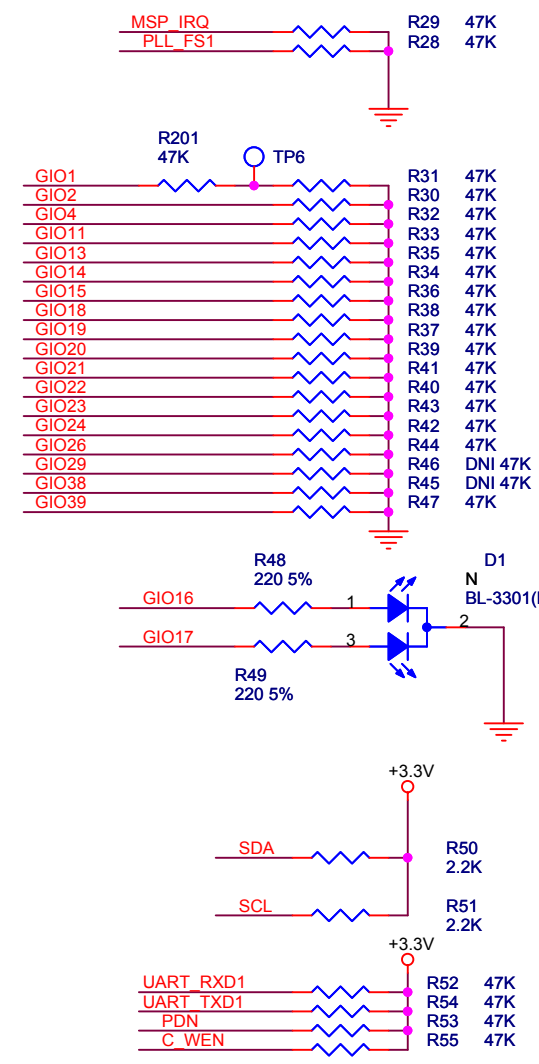
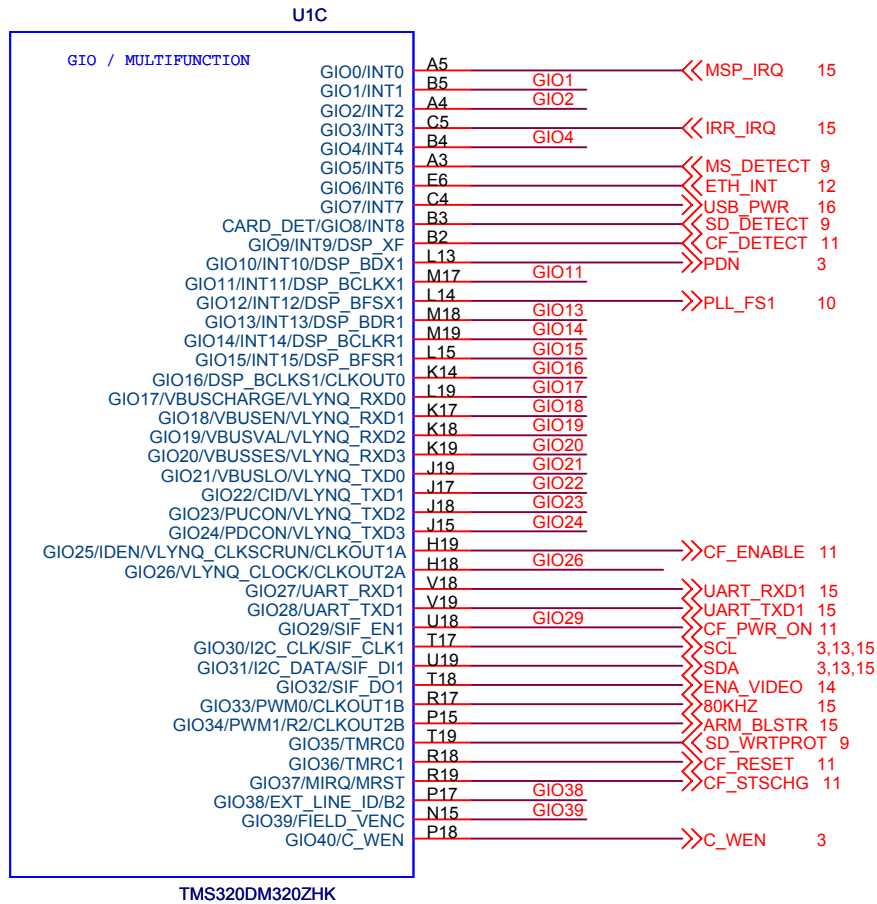

Title		
DM320 GIO		
Size	Document Number	Rev
A4	NEUROS RECORDER-3	B
Date:	Friday, August 11, 2006	Sheet 5 of 17

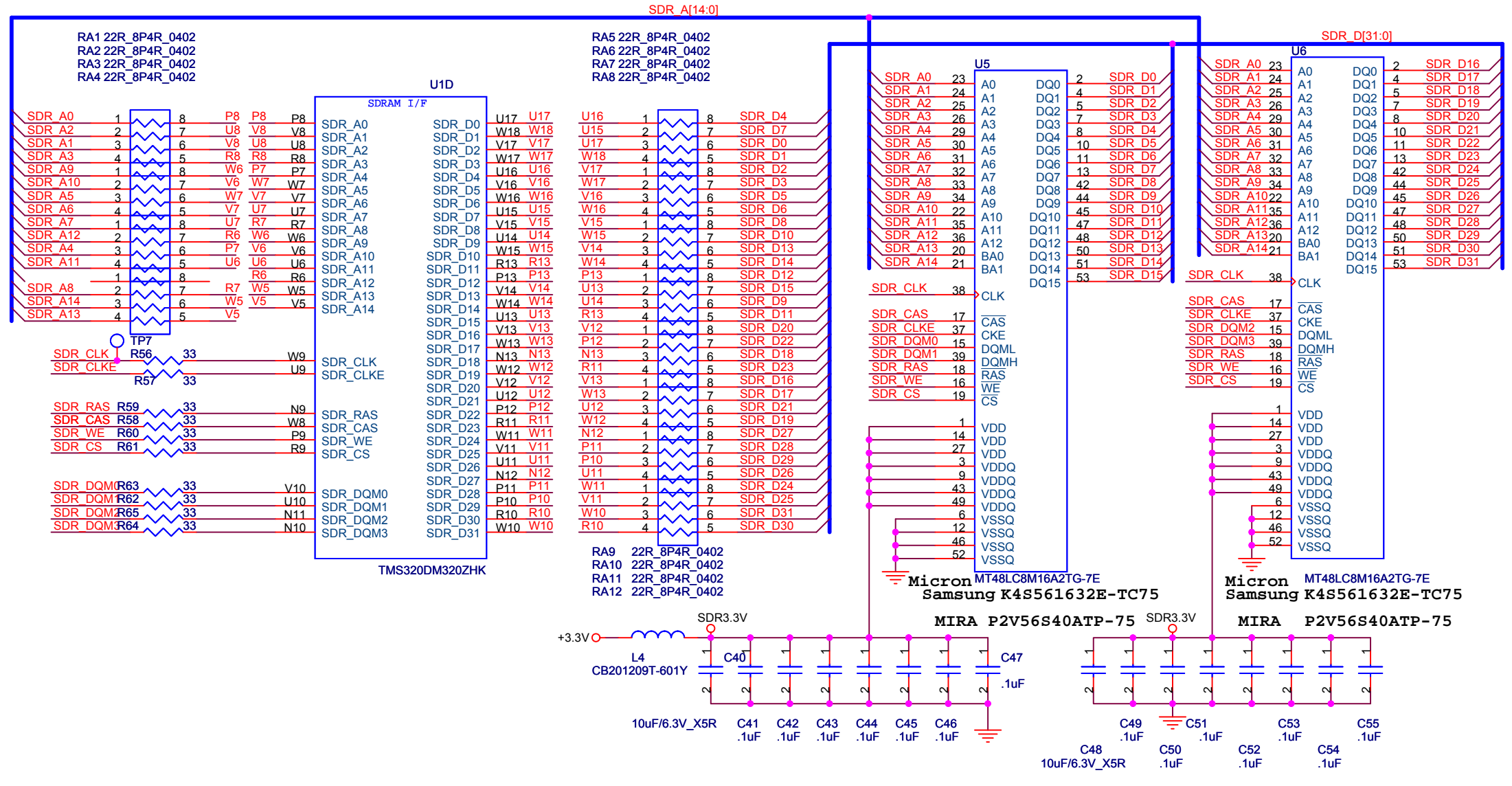

Title		
SDRAM		
Size	Document Number	Rev
A4	NEUROS RECORDER-3	B
Date:	Friday, June 30, 2006	Sheet 6 of 17

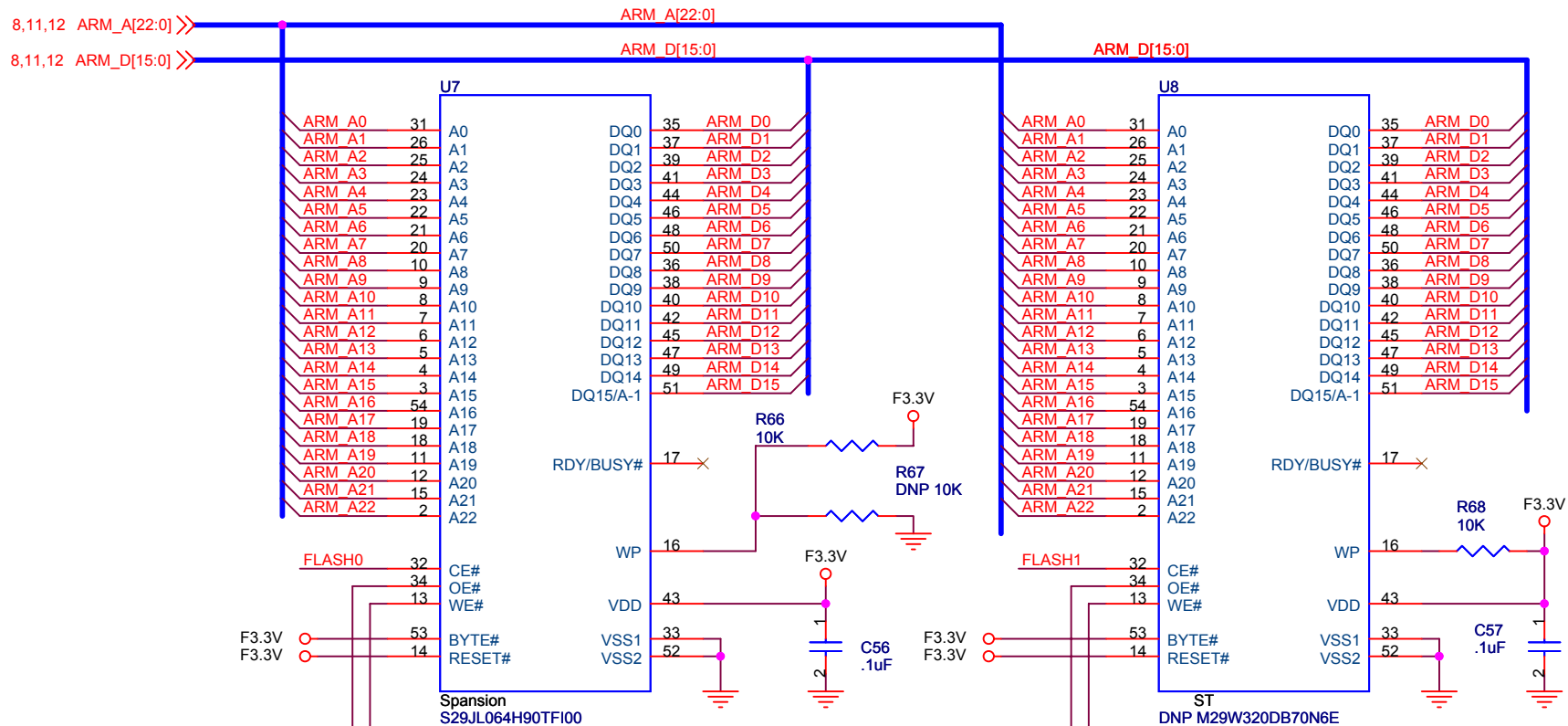

8,12 EM_OE >>> EM_OE
8,11,12 EM_WE >>> EM_WE

- 4 MB ST M29W320DB70N6E
- 8 MB Toshiba TC58FVM6B2AFT65
- 8 MB Spansion S29JL064H90TFI00
- 16 MB Toshiba TC58FVM7B2AFT65(80)
- Max combined capacity is 16 MB

Place R66: Boot sector write enabled
Place R67: Boot sector write disabled

Place U9 when using 2 FLASH chips, U7 and U8
Place R71 when using 1 FLASH chip, U7 only

Place R69 when U7 is 8 MB
Place R70 when U7 is 4 MB

Title		
NOR FLASH		
Size	Document Number	Rev
A4	DM320 Reference Design	B
Date:	Thursday, July 13, 2006	Sheet 7 of 17

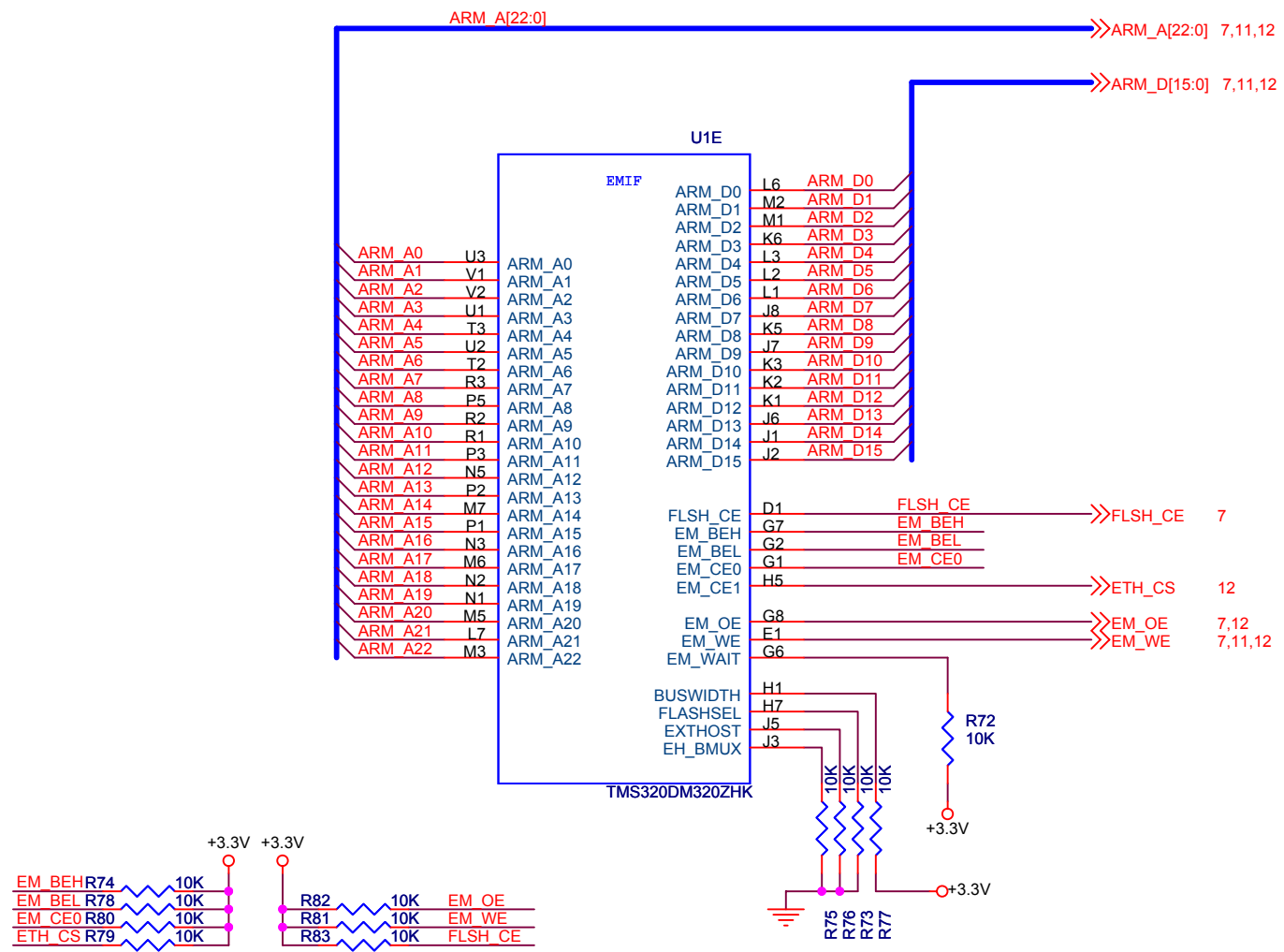

Title		
DM320 EMIF		
Size	Document Number	Rev
A4	NEUROS RECORDER-3	B
Date:	Friday, June 30, 2006	Sheet 8 of 17

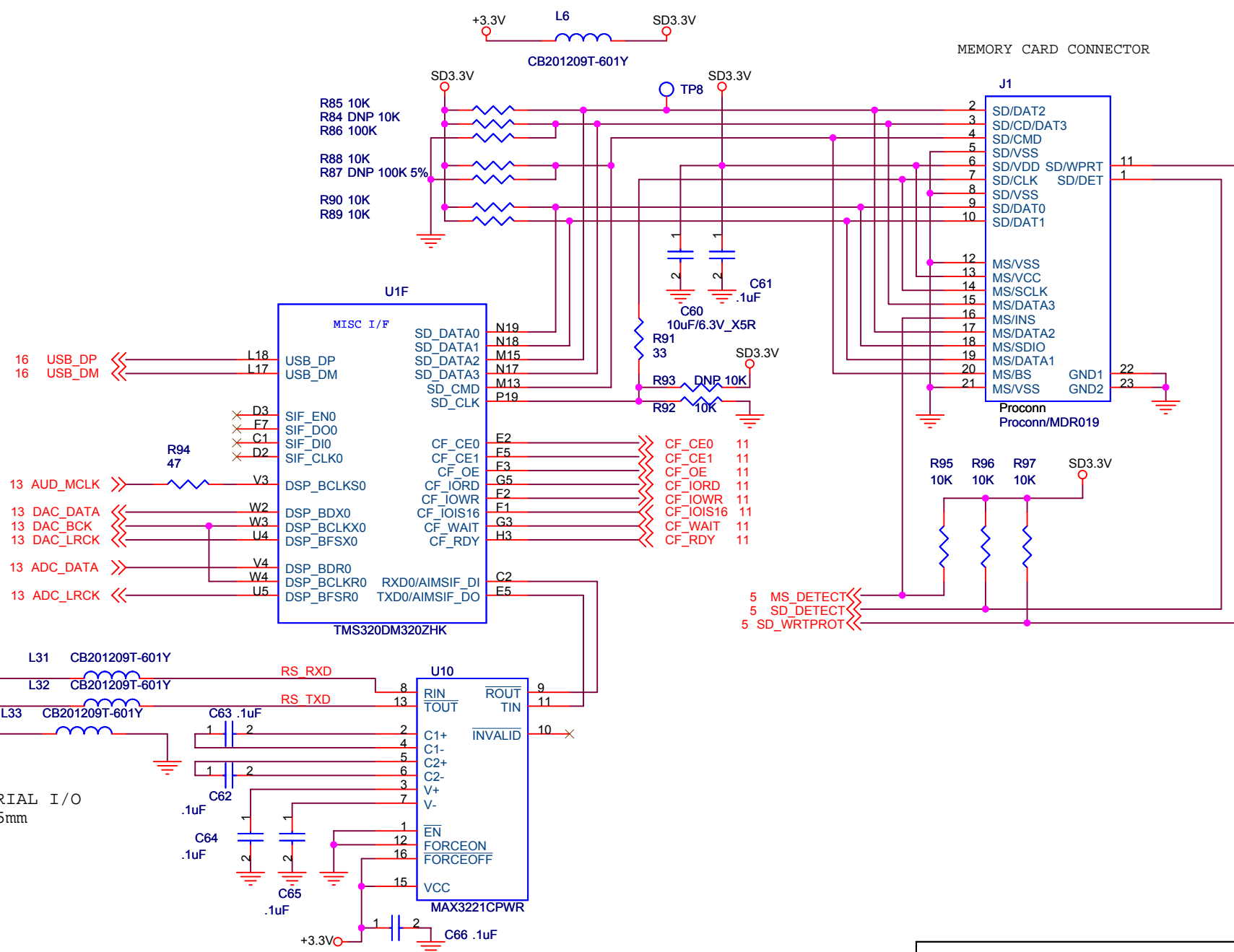

Title		
MISC I/O; SD/MS CARD; UART0		
Size	Document Number	Rev
A4	NEUROS RECORDER-3	B
Date:	Thursday, July 13, 2006	Sheet 9 of 17

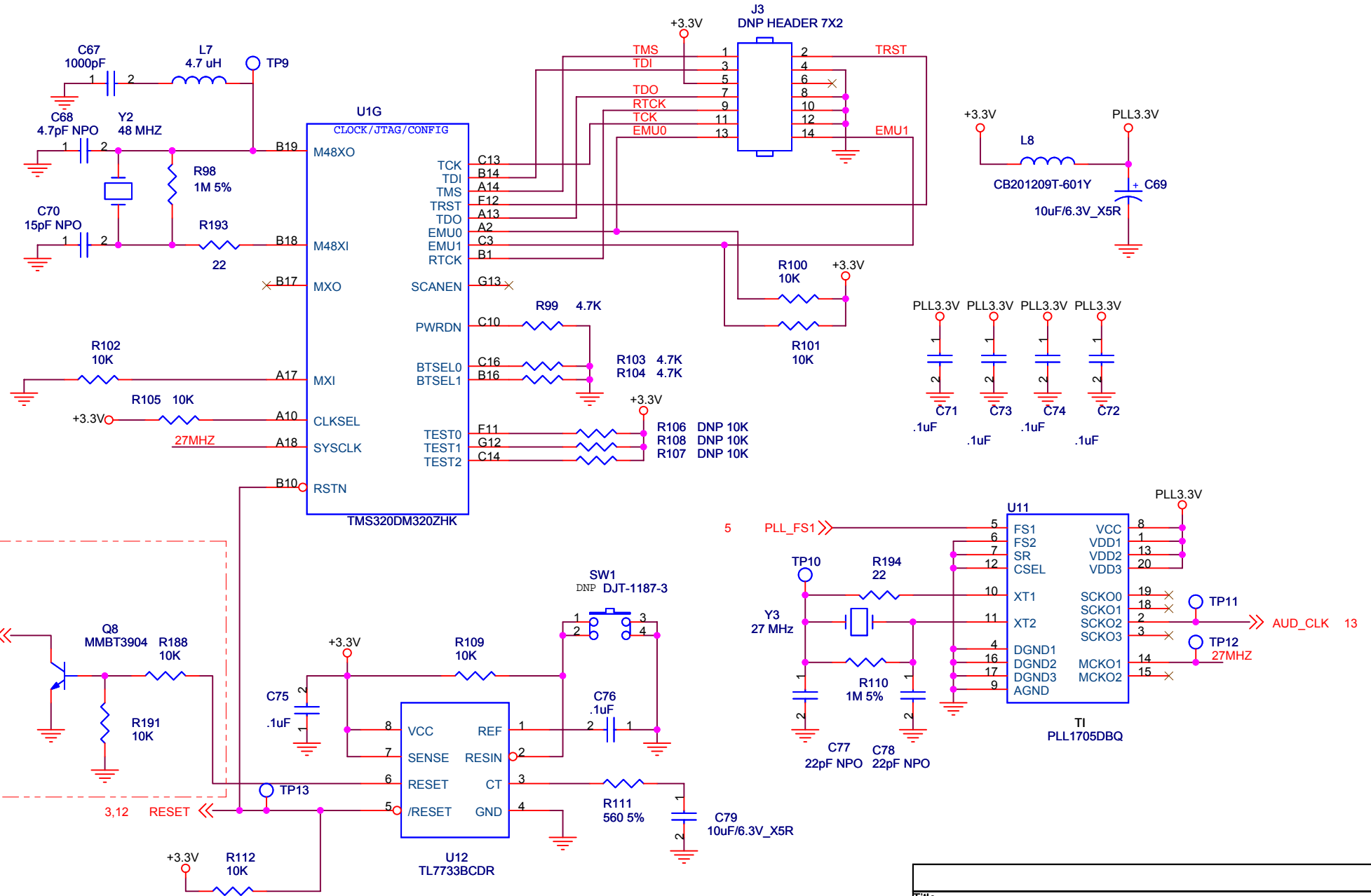

Title		
CLOCKING; POR; JTAG		
Size	Document Number	Rev
A4	NEUROS RECORDER-3	B
Date:	Thursday, July 13, 2006	Sheet 10 of 17

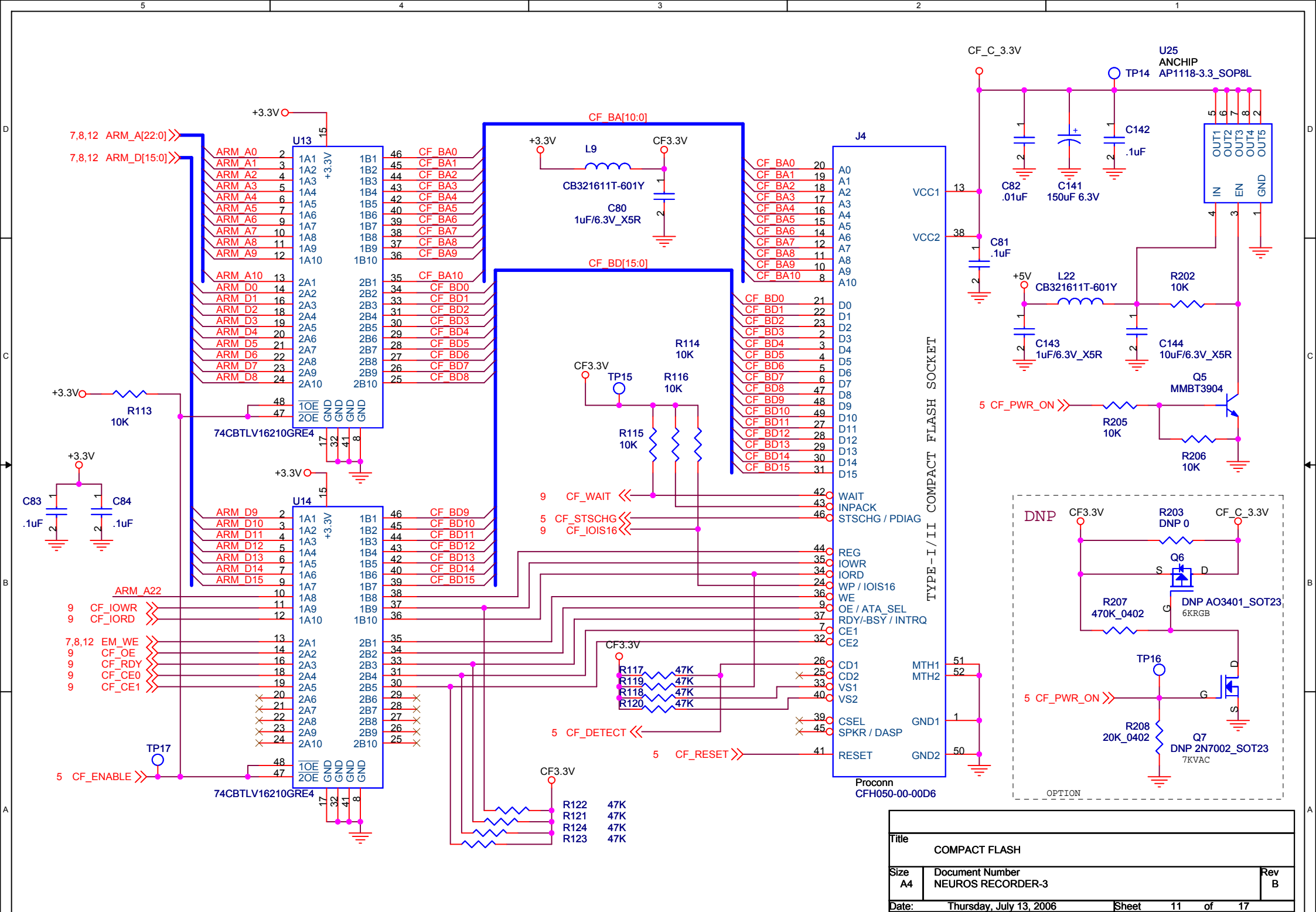

Title		
COMPACT FLASH		
Size	Document Number	Rev
A4	NEUROS RECORDER-3	B
Date:	Thursday, July 13, 2006	Sheet 11 of 17

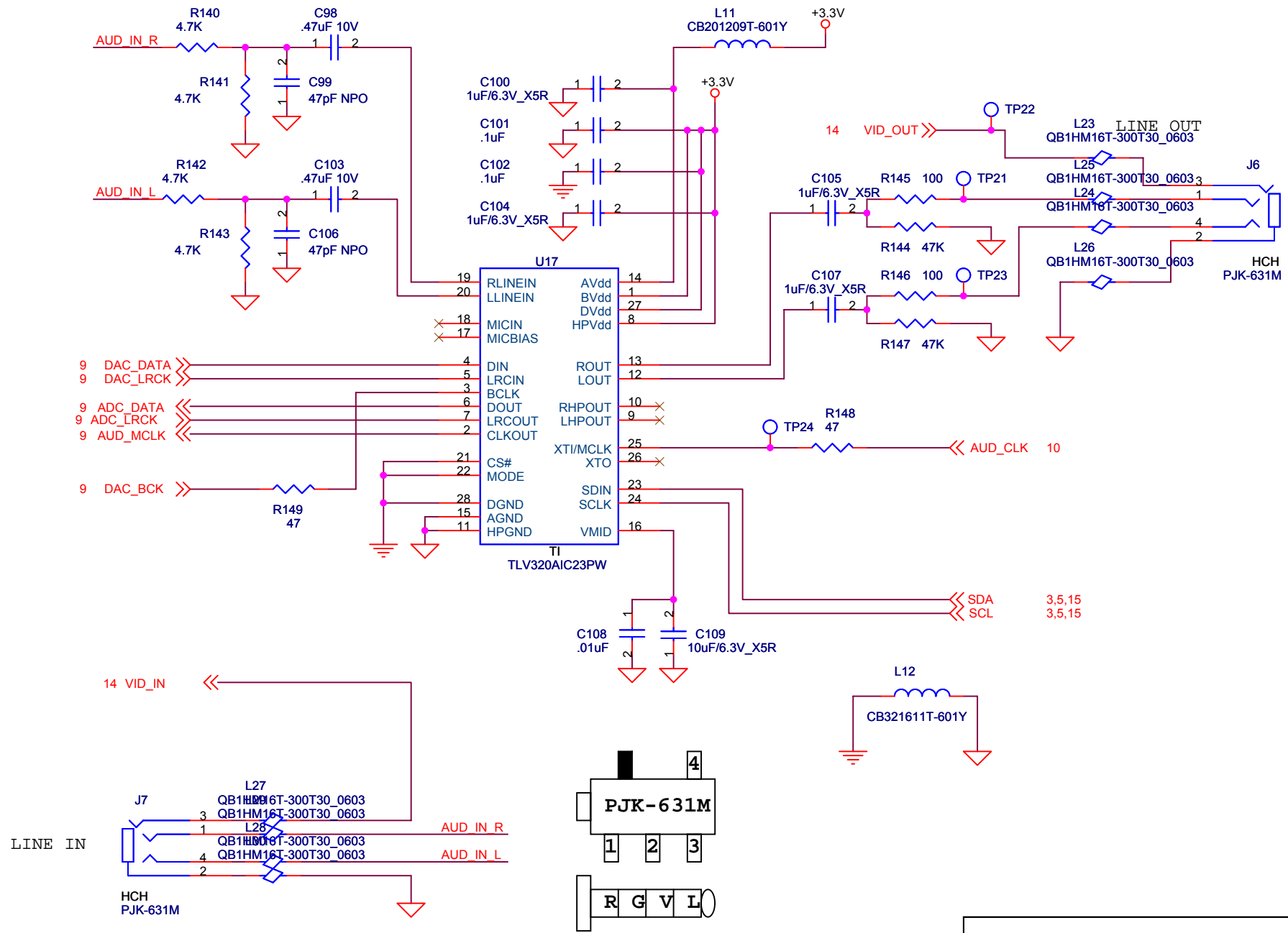

Title		
AUDIO ADC/DAC		
Size	Document Number	Rev
A4	NEUROS RECORDER-3	B
Date:	Tuesday, July 11, 2006	Sheet 13 of 17

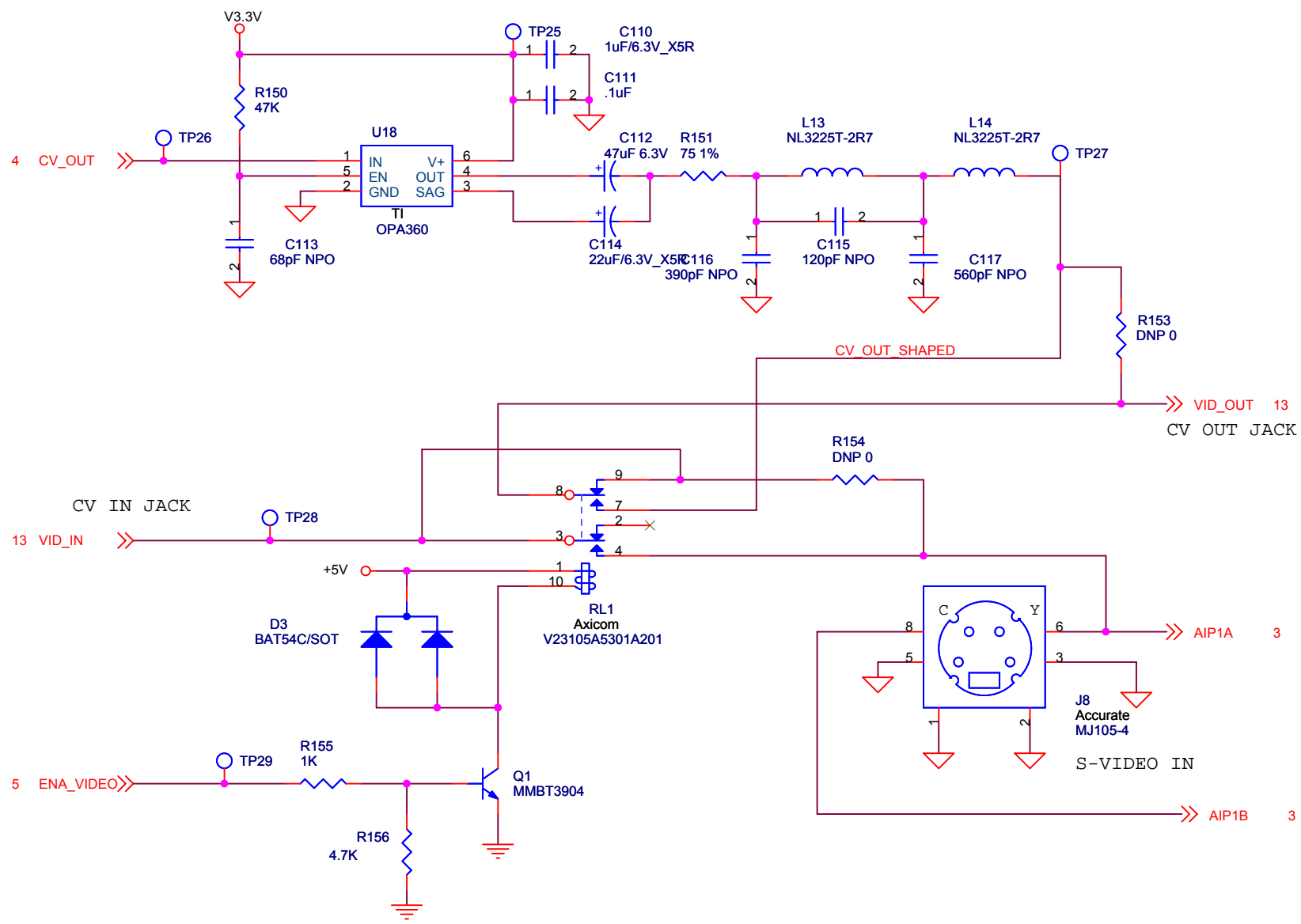

Title		
VIDEO OUT BUFFER		
Size	Document Number	Rev
A4	NEUROS RECORDER-3	B
Date:	Friday, June 30, 2006	Sheet 14 of 17

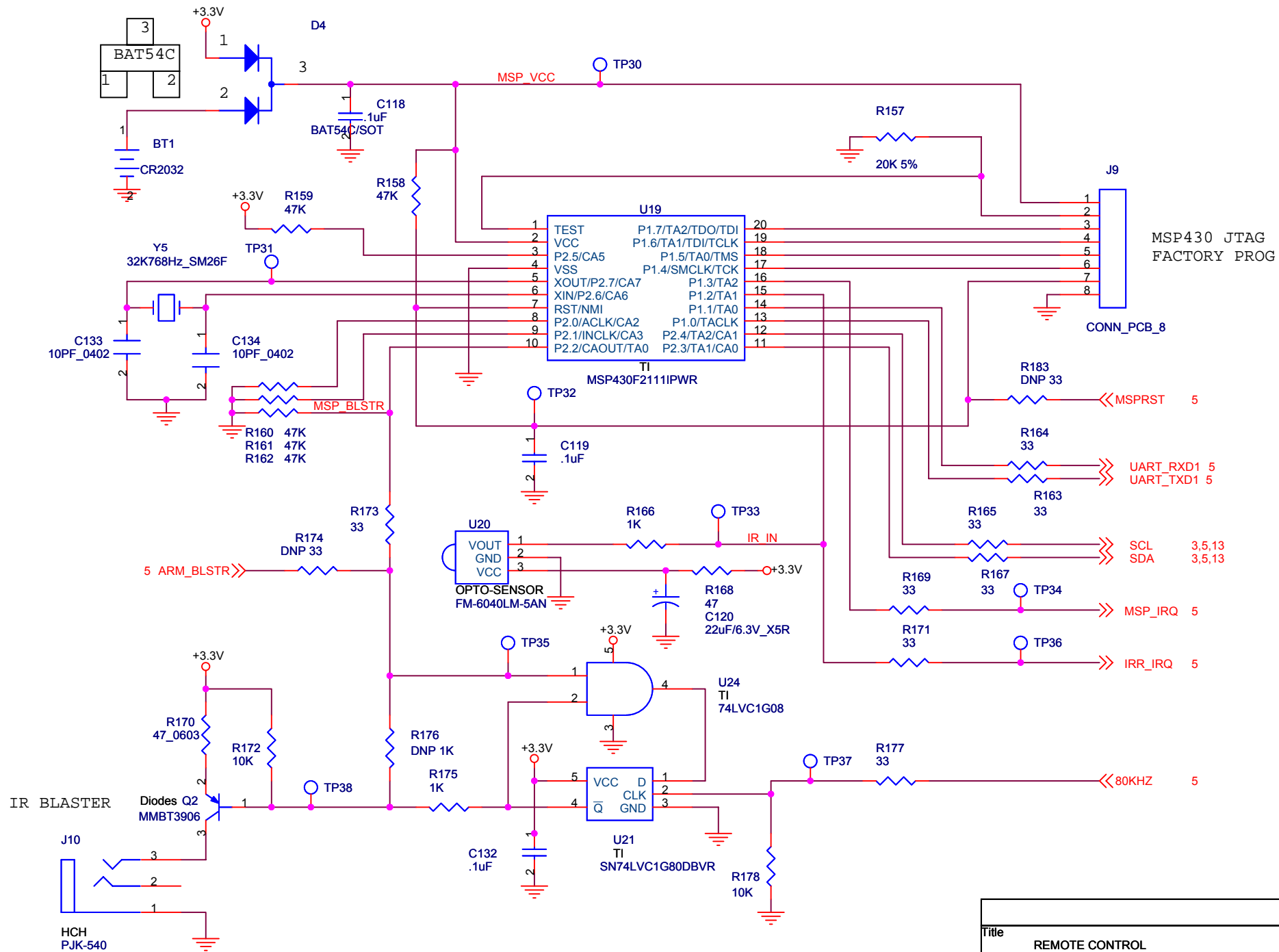

Title		
REMOTE CONTROL		
Size	Document Number	Rev
A4	NEUROS RECORDER-3	B
Date:	Friday, August 11, 2006	Sheet 15 of 17

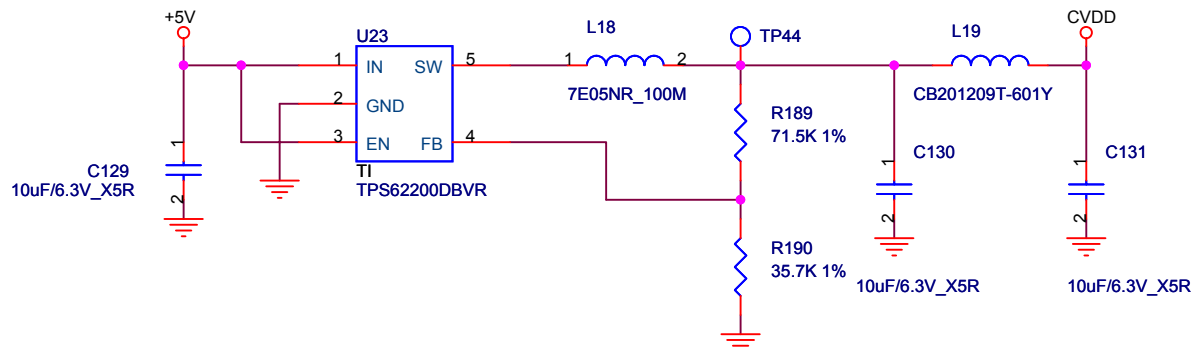
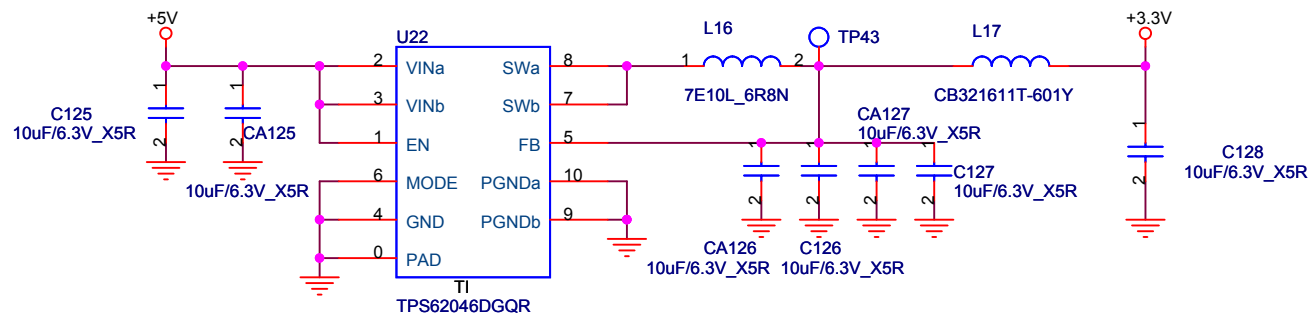
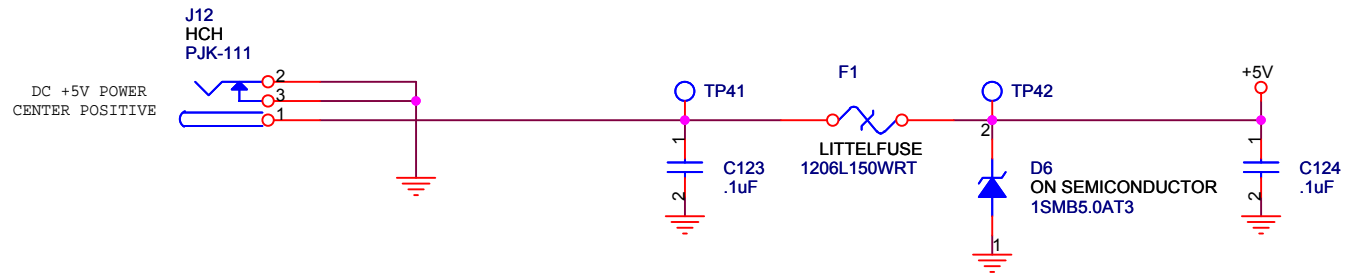

Title		
POWER SUPPLY		
Size	Document Number	Rev
A4	NEUROS RECORDER-3	B
Date:	Thursday, July 13, 2006	Sheet 17 of 17