

Bell Helicopter
A Textron Company

POCKET GUIDE



Bell

AH-1Z

- TODAY'S CHALLENGE -

The number one challenge facing armed forces on today's battlefields is the requirement to positively identify friend from foe and then be able to attack hostile targets with precision munitions so as to reduce or eliminate collateral damage to civilian personnel and property.

To give our crews the best opportunity to survive on the battlefield, positive identification and target engagements must be done at ranges that keep the aircraft well outside the effective range of enemy guns.

**ONLY THE AH-1Z CAN
MEET THIS CHALLENGE!**

ONE STRIKE . . .

. . . YOU'RE OUT

Bell Helicopter

A Textron Company

Table of Contents

| | |
|--|----|
| Introduction | 4 |
| Background/History | 6 |
| General Characteristics | 8 |
| External Dimensions | 10 |
| Design Features | 12 |
| Airframe | 12 |
| Modular Construction | 13 |
| Landing Gear | 14 |
| Standard Skid Landing Gear | 14 |
| Northrop Grumman Integrated Cockpit & Avionics ... | 16 |
| AH-1Z Integrated Cockpit | 18 |
| Multifunction & Dual Function Displays | 20 |
| Flight Controls | 26 |
| Automatic Flight Control System | 26 |
| Lockheed Martin Target Sighting System (TSS) | 28 |
| TSS Sensors | 30 |
| TSS Performance | 31 |
| THALES Helmet Mounted Sight & Display System ... | 32 |
| Weapons Systems | 34 |
| Rockets | 36 |
| Hellfire | 37 |
| 20mm Turret Gun | 38 |
| Sidewinder | 39 |
| Rotor Systems | 40 |
| Main Rotor | 41 |
| Tail Rotor | 43 |
| Blade Folding | 44 |
| Shipboard Compatibility | 45 |
| Propulsion System | 46 |
| Particle Separator & Engine Systems | 48 |
| Hover Infrared Suppression System | 49 |
| Hydraulic Systems | 50 |
| Pneumatic Subsystem | 51 |
| Electrical Systems | 52 |
| Electric Power Schematics | 53 |
| Environmental System | 54 |
| Fuel System | 55 |
| Performance | 57 |
| USMC Baseline Configuration | 58 |
| Survivability Features | 60 |
| H-1 Program Description | 62 |
| UH-1Y – AH-1Z Commonality | 63 |
| Optional-Cobra Radar System (CRS) | 64 |
| CRS Cockpit Displays | 66 |
| Optional-Integrated Countermeasures (ALQ-211) | 67 |
| ALQ-211 Key Functions | 68 |

Introduction

The all new AH-1Z attack helicopter incorporates the latest advances in military avionics, weapons systems, electro-optical sensor systems and rotary wing technology to provide a totally integrated weapons platform with the ability to locate and identify targets at unprecedented ranges, engage those targets with precision munitions, and survive on both urban and conventional battlefields.



In an era where it has become an absolute necessity to distinguish friend from foe, an advanced Target Sighting System [TSS] with third generation FLIR permits positive target identification under virtually all weather conditions at ranges that exceed the on board weapons systems' maximum range.

A choice of organic weapons systems include Hellfire missiles, 2.75 inch rockets, 20mm cannon, and AIM-9 Sidewinder missiles permits precision ground and air-to-air target engagements.



The AH-1Z is fully marinized and capable of shipboard operations anywhere in the world. Manufactured for the US Department of Defense by Bell Helicopter, the AH-1Z is the most capable and lethal armed helicopter in the world.



Background/History

When the U.S. Army first employed the AH-1G Cobra in combat, it validated the concept of the tandem cockpit design, which today is standard on virtually all attack helicopters. AH-1 Series Cobras account for over 70% of all non Soviet tandem seat armed helicopters ever delivered. Currently, AH-1 Cobras are flying on a 24 hour basis world wide for the U.S.A., Israel, Jordan, Korea, Taiwan, Turkey, and Pakistan. From this long line of heritage and experience, the AH-1 Cobra evolved into what is today the preferred choice of the U.S. Marine Corps and top fighting forces throughout the world, the Bell AH-1W Twin Engine SuperCobra. And now, the next generation Cobra, the AH-1Z, is here.





In conjunction with the U. S. Marine Corps, Bell Helicopter Textron has undertaken a major modification and remanufacturing effort which will convert existing AH-1Ws into the AH-1Z. Changes to the aircraft include a completely new state-of-the-art integrated “glass cockpit”, Integrated Helmet and Sighting System, upgraded more powerful transmission and drive system, 10,000 hour airframe life, better corrosion resistant materials, and a new hingeless, bearingless four-bladed foldable rotor system. The new rotor drastically improves ballistic survivability, more than doubles the payload capacity and increases the SuperCobra’s functional flight envelope by 80%. Yet at the same time, maintenance demands, as well as operating costs, have been dramatically reduced.



General Characteristics

The AH-1Z is a tandem two seat, twin-engine, single rotor attack helicopter based on the **USMC AH-1W** and is powered by two **General Electric T700-GE-401 engines**.

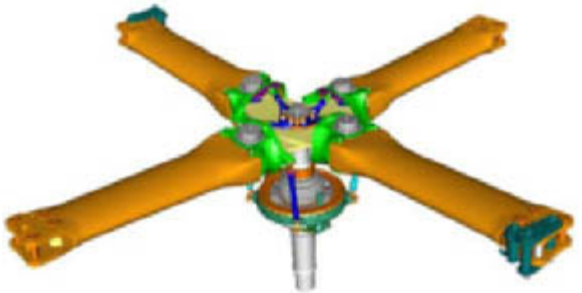

The drive system is comprised of a four-bladed composite main rotor, bearingless rotor head with semiautomatic blade folding system, new main transmission with higher output capability, and improved higher output tail rotor drive system and four-bladed tail rotor. The incorporation of the new rotor system gives the AH-1Z enhanced performance, increased payload capabilities, increased speed, and smoother ride.

The AH-1Z cockpit configuration features state-of-the-art communication, navigation, and fire control equipment. It also incorporates an integrated cockpit with Thales “TopOwl” Helmet Mounted Sight Display [HMSD], digital aircraft moving map capability, and the Lockheed Martin Target Sighting System [TSS]. The navigation equipment consists of dual Embedded Global Positioning Systems with Inertial Navigation (EGI).



The AH-1Z incorporates the most capable armament and fire control system available today. The armament system is a fully integrated platform which consists of a 20mm turret system (3 barrel cannon), 2.75 inch (70mm) Wrap-Around Fin Aerial Rockets; Hellfire missile system, and the AIM-9 air-to-air missile system. The armament stores are mounted in a variety of combinations on six external ordnance stub wing store stations (four of which are universal). The ordnance can be guided at night and during adverse weather by use of the Target Sighting System. Also integrated with the armament system of the AH-1Z are the Armament Control and Display System, Pilot and Gunner Helmet Mounted Display, and Airborne Target Handover System.

External Dimensions

The small silhouette and shape of the AH-1Z as well as low IR reflective paint greatly contributes to the survivability of the aircraft. The fuel system is ballistically tolerant with built-in fire suppression and internal (integral), self-sealing, crashworthy tanks in the weapons pylons that increase fuel capacity for extended mission range.

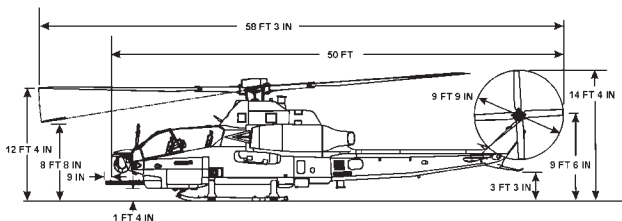
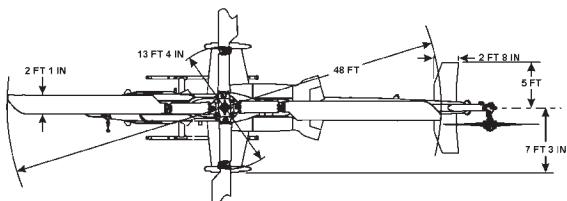
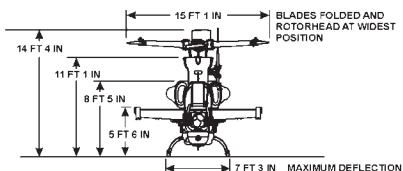

HZ_FM_FM107_001_01_C00

The AH-1Z attack helicopter offers more payload versatility than any other attack helicopter currently in production in the world. These capabilities dramatically increase the performance and lethality, especially in hot high environments.

Widely acknowledged for their proven reliability and low fuel consumption, the modular designed T700 series engine, two of which power the AH-1Z and UH-1Y, also power both the Bell AH-1W and 214ST, as well as the UH-60 Blackhawk and other US Government and International aircraft. The T700-GE-401 engine is the most fuel efficient engine in hot day high altitude performance.



The AH-1Z is also considered the most survivable attack helicopter in the world. Its design includes vulnerability reduction, susceptibility reduction, and crashworthiness. Standard AH-1Z survivability equipment includes the Hover Infrared Suppressor System (HIRSS) for the engine exhausts, Radar Warning Receiver, Countermeasure Dispensers, Laser Warning System, and Missile Warning Set.



Design Features

Airframe



The AH-1Z utilizes a combination of conventional metal aerospace construction, as well as composite materials where applicable, to reduce cost and weight and improve reliability and ballistic tolerance. The fuselage consists of two main sections; the forward (cockpit) section, and the aft (tailboom) section. The forward section includes tandem crew cockpits, landing gear, weapon pylons, power plant and pylon assembly. The tailboom section supports the tail group, tail skid, tail rotor, and tail rotor drive system. The **minimum design life** of the Airframe is **10,000 flight hours**.

Modular construction

- Large structural assemblies: forward fuselage section, tailboom section, wings.

Airframe material and construction

- Forward fuselage - Aluminum and Fiberglass honeycomb construction enclosed by Aluminum alloy skins.
- Tailboom section - Aluminum skin, longerons, and stringers.
- Wings - Aluminum spar, rib, and skin construction.

Major fittings

- Predominately metal: Steel, Titanium, Aluminum.

Modular Construction

Forward [Cockpit] Section



Wings [Pylons]

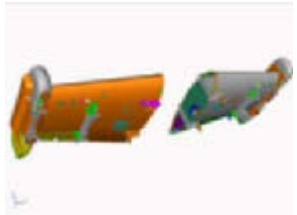

Aft [Tailboom] Section

The Airframe, Drive System and the Rotor System have the **growth capacity** to be able to increase the gross weight approximately 1,000 pounds to allow for heavier wingstore capacity such as auxiliary fuel tanks which greatly increase the mission range and allow for the full integration and utilization of future weapon systems.



Landing Gear

The **standard skid type landing gear** incorporates high strength energy attenuating “**rectangular**” cross tubes for protection of the airframe and crew in the event of hard landing. Towing is possible with the aircraft at a maximum weight of 18,500 pounds over smooth surfaces, using two each forward and aft ground handling wheel sets. The skid landing gear has a limit sink speed requirement of **3.66 m/sec (12 fps)** and a reserve energy sink speed of **4.48 m/sec (14.7 fps) @ Basic Design Gross Weight**. Skid mounting is designed to eliminate susceptibility to main rotor ground resonance. The skid gear is attached to the lower fuselage structure and is readily replaceable in the field.

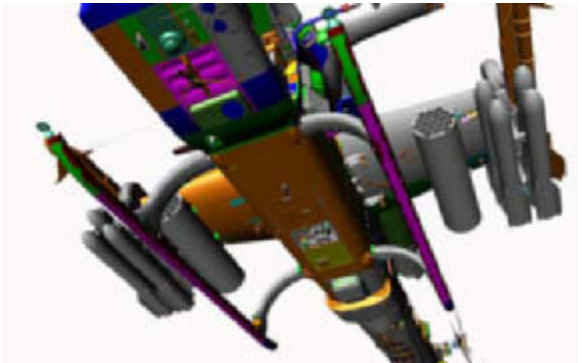

Standard Skid Landing Gear



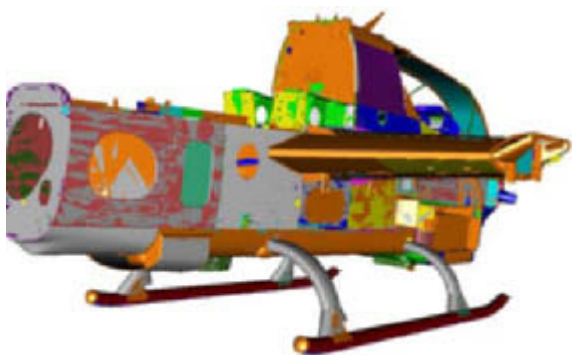

Northrop Grumman Integrated Cockpit & Avionics

THE TOTAL INTEGRATED AVIONIC SYSTEM (IAS)

Northrop Grumman has the responsibility for the design, development, and delivery of the H-1 Integrated Avionics System (IAS), which includes cockpit displays and controls, communications, navigation, external stores and weapons management system, and a central mission computing subsystem.

Maximum commonality of product across platforms; achievement of redundancy and backups in all critical areas of processing, displays, and essential sensors; and planned reserves of processing and 1553 bus bandwidths are delivered within the Integrated Avionics System (IAS). At the heart of the IAS is the Mission Computer, which controls all aspects of mission performance from flight instrumentation to weapons engagement.

The figure on the next page shows the total complement of components and architecture for the AH-1Z. The UH-1Y IAS uses identical displays and mission computers, but does not have the weapons module. Beyond those items of displays, sensors and weaponry are elements that support other key functions. These include:

Communications: utilizing the new U.S. Navy standard RT-1824 integrated radio, UHF/VHF, COMSEC, and a modem are combined into a single unit.

Navigation: is primarily achieved with the U.S. Navy Embedded GPS Inertial (EGI) and air data subsystem, which in the case of the AH-1Z, is a low airspeed subsystem necessary to support weapons delivery in hover or at near zero speed. Backup sensors and displays are provided in the event of a total IAS failure. A modern, U.S. Navy standard digital map system is used as the navigator map display source, plus a threat visibility indicator, and is part of the in-flight mission-planning mode.

EW/Self-Protection: consists of the Northrop Grumman APR-39B(V)2 radar warning receiver together with the AAR-47(V)2 missile warning/laser detection system.. The APR-39B(V)2 is upgraded to provide full MIL-STD-1553B access of threat warning. It also provides data to the Mission Computer, for optimal integration of threat situational awareness. The ALE-47 countermeasures dispensing subsystem is provided for 360 degree protection.

INTEGRATED COCKPIT / AVIONICS ARCHITECTURE

**GPS / INERTIAL NAVIGATION
INTEGRATED TACTICAL COMMUNICATION
ADVANCED EW SELF-PROTECTION
DIGITAL MAP SYSTEM**

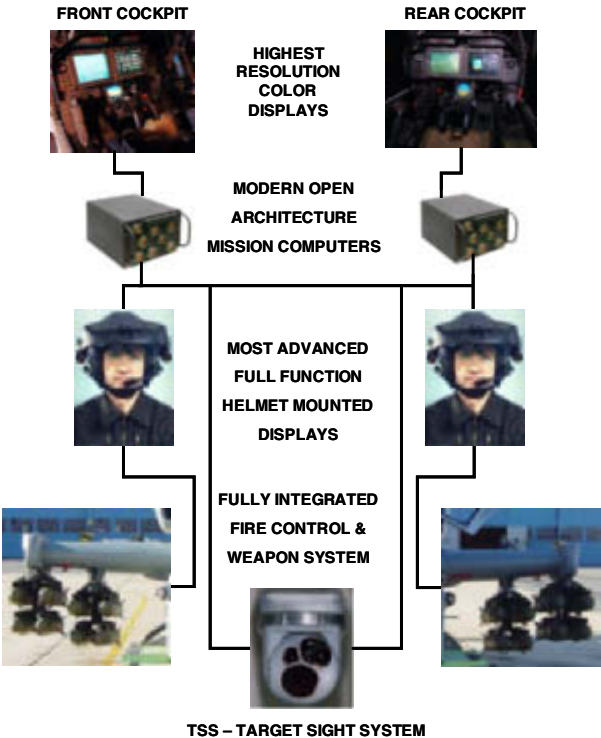

AH-1Z Integrated Cockpit

The AH-1Z cockpit was designed for maximum commonality and inter-operability. The location of controls and displays in the front and rear crew stations are **nearly identical**. This allows crew members to perform the pilot and battle captain/gunner roles from either crew station. Flight controls consist of a side stick cyclic, collective, and pedals. To enable maximum hands-on system control by the flying pilot, switch functions on the cyclic and collective control grips include: automatic flight control system adjustment, helmet mounted display with symbology declutter levels, weapon select and fire, wings stores selective and emergency jettison, electronic warfare countermeasures dispensing control, radio select, frequency select, press to talk, search light control, and multifunction display page selection.

FRONT COCKPIT



Located in both crew stations is a **mission grip** that provides all the switch control functions to operate the AH-1Z's target sight system's field of view, slew, track, and acquire, as well as the weapons system's select and launch functions. The mission grip is designed for use by the crewmember who is functioning as the battle

captain gunner. Each crew station has **two 8 x 6 inch multifunction displays [MFD]** with which the crew interfaces with majority of subsystem functions. Each crew station also has a **single 4.2 x 4.2 inch dual function display [DFD]** and a single data entry keyboard, both located on a translating stowable console in the center of the crew station. During normal operation the dual function display presents standard display page formats. However, in the unlikely event of a total avionics system failure, it will present the standby flight instrument symbology.

REAR COCKPIT



MISSION GRIP



Multifunction & Dual Function Displays

Both the multifunction and dual function displays are **active matrix liquid crystal color displays**. The display page formats are organized based on mission requirements.

The **flight display** presents horizontal and vertical situation indication displays for instrument flight as well as drive train status and other status indications.



Standby Flight Symbology on DFD

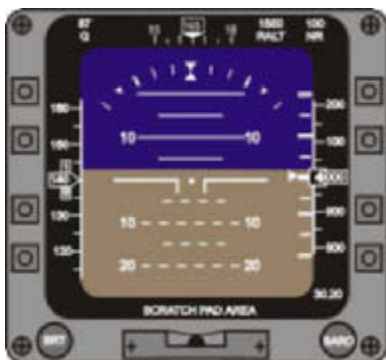

The **systems display** presents the status of the engines, drive train, hydraulic, electrical, and various other aircraft systems.



The **warning caution advisory display** in conjunction with verbal and nonverbal signals alerts the crew that a system limitation has been exceeded or a system is operating in a degraded mode.



The **warning caution alert** function presents critical information on the flight display to prompt the crew to call up the detailed warning caution advisory page.



The **voice communications display** format presents selectable and editable lists of frequencies and call signs. The **tactical digital communications display** presents formats for composing and transmitting various tactical digital messages, as well as receiving incoming messages.



Voice Communications Display on DFD



The **digital moving map display** in conjunction with the aircraft's embedded GPS/INS system allows precise navigation and enhanced situational awareness by displaying battlefield graphics including threat locations and inter-visibility indications.



The **electronic warfare display** provides warning indications of radar, laser, and missile launch threats, as well as allowing the setup of the counter measures dispensing functions.



The **weapon display** graphically depicts the munitions onboard the aircraft and allows the setup of weapon inventory and deployment modes.



The **target display** presents the selected video picture, FLIR, or color TV from the target sight system along with targeting information and provides controls for various target sight system modes along with sight status information.



The AH-1Z Attack Helicopter Integrated Avionics System (IAS) has been developed utilizing the software open architecture approach. The computer has a **50% growth capacity**. This growth capability in the Avionics and Weapons Systems, plus that in the Airframe, Drive System, and Rotor System, add significantly to the useful mission life and long term effectiveness of the AH-1Z Attack Helicopter.



Flight Controls

Flight controls consist of a side stick cyclic, collective, and directional pedals at each crew station. Mechanical linkages (push-pull tubes) transmit pilot inputs to the hydraulic boosted controls (no cables are used).

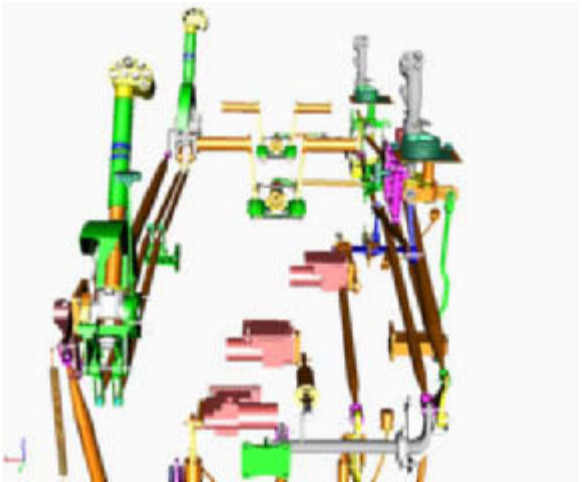

Automatic Flight Control System

The AFCS incorporates a four-axis (pitch, roll, yaw, and collective) fail passive Stability Control Augmentation System (SCAS). The AFCS also has the following additional modes of operation: Heading Hold, Attitude Hold, Speed Hold, Cruise Hold, Altitude Hold, Hover Hold, Hover Wave-off, and Force Trim.

Heading Hold mode holds heading within ± 1.0 degrees, steady state, of the heading existing at the time of engagement.

Attitude Hold mode operates in conjunction with SCAS to provide pitch and roll attitude stabilization. This mode maintains the pitch attitude within 1.0 degrees, and roll attitude within 1.0 degrees of the attitude existing at the time of engagement.

Speed Hold mode maintains airspeed or groundspeed

at the time of engagement within ± 3 kts steady state from the reference, and within ± 10 kts, (or $\pm 10\%$ of the reference speed) in moderate turbulence.

Altitude Hold mode maintains the altitude existing at the time of engagement through the collective axis. This mode holds either barometric (BARO) or radar (RALT) altitude depending on the altitude reference source selected and the flight condition.

Cruise Hold mode automatically engages and maintains heading hold, altitude hold, and speed hold.

Hover Hold mode causes the helicopter to make a smooth deceleration from 15 kts (or less) groundspeed to a stable hover while maintaining a constant radar altitude and constant heading. After achieving a stable hover, the Hover Hold mode maintains a position as measured by the integration of the ground velocity signals. The position for hover hold is the position at which ground velocity becomes less than 0.5 kts. In a steady wind with constant heading, the helicopter maintains a steady state hover within a 10 foot diameter circle.

Wave Off mode causes the helicopter to transition from the flight condition at engagement to a terminal speed and altitude that has been pre-selected and displayed via the Multi Function Display (MFD).

Force Trim capabilities include pilot ability to reduce the control forces to zero by actuation of trim release switches on the cyclic and collective control sticks. Incremental force trim (beep trim) capability is available via the trim actuators and is controlled by appropriate beep switches on the cyclic and collective control sticks.

Incremental Mode Trim (beep trim) capability is provided for the described modes herein.

With any Hold mode engaged, the pilot is able to move the controls (**Fly-Through**) by overriding the force feel spring force and control friction forces. Displacement of the controls from the trim position results in temporary disengagement of the mode. When the control is returned to the trim position, the mode reengages and returns the helicopter to the trim condition existing prior to override.

Lockheed Martin Target Sighting System (TSS)

- Provides day/night/adverse weather target acquisition and designation
 - Air-to-Air and Air-to-Ground modes
 - Designation for Hellfire Missile
- Third generation midwave FLIR with four Fields Of View
- FOV matched color TV
- Option to incorporate a Laser Spot Tracker for off-board and remotely designated targets
- Highly accurate transfer alignment for precision targeting of off-board assets
- Advanced multimode, multi-target auto tracker
 - Track 3 active targets, 10 inertial targets
 - Offset track & aimpoint adjust
 - Track modes (scene correlation, contrast and centroid)
- Self-contained automatic boresight
- High reliability, two-level maintenance
- Extensive use of COTS/NDI hardware & software
- Field of Regard is + 120° Azimuth & +45°/-120° Elevation
- Line of Sight (LOS) slew with Mission Grip or Helmet Mounted Display
- Imagery/Data provided to Mission Computer and 8mm VCR
- Fully Integrated with Fire Control System
- Range/Aiming data included in Firing Solutions for All Weapons
- External and Internal Boresight
- AIM-9 Seeker can be slaved to TSS LOS
- FLIR or TV Tracking

See First, Strike First

Longer Range Performance Provides for:

- Rapid wide area search and target detection
- Maximum standoff and survivability
- Enhanced situational awareness
- Mission versatility

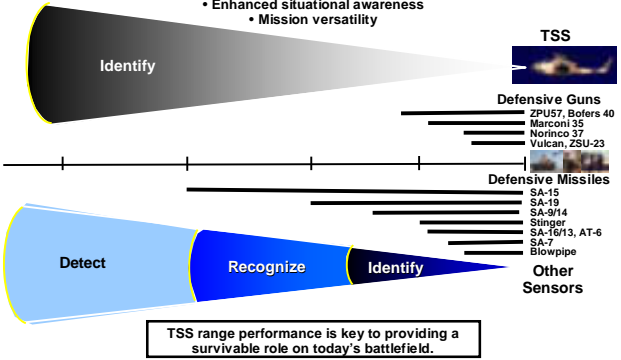

Targeting System Comparison

The Bottom Line

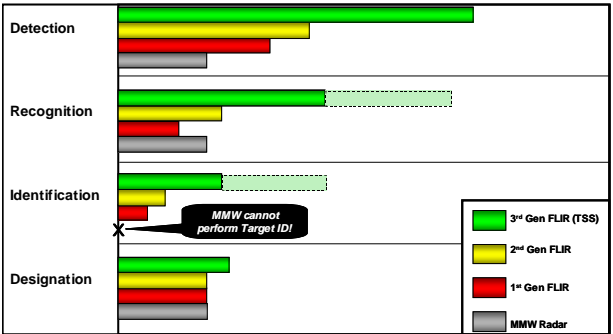

TSS Sensors



Target Sight System



- 3rd-generation FLIR
- Large aperture optics
- 5-axis gimbal, unprecedented stabilization
- Low-light color TV
- Image enhancement
- Eye-safe laser rangefinder
- Option for laser spot tracker

**Fully Integrated with AH-1Z
Fire Control System**

TSS Performance

The TSS FLIR images below are of downtown **Orlando, Florida** from **13-15 Kilometers**.



Wide Field of View

Medium Field of View



Narrow Field of View

**Narrow Field of View
(Zoom)**



THALES *TopOwl* Helmet Mounted Sight and Display System

An important functional element of the AH-1Z cockpit display is the TopOwl Helmet Mounted Sight and Display (HMSD) System. This helmet supports improved communication and reduces cockpit workload leading to improved mission effectiveness. Manufactured by THALES Avionics, the TopOwl HMSD is the most technically advanced helmet currently available and in service, offering unparalleled supportability and the capacity of technology insertion as additional requirements develop. The TopOwl HMSD combines both avionics functions with the aircrew life support and protection functions into a single unit.

Key features of the TopOwl HMD include:

- True 24 hour day/night capability using image intensified night vision technology
- High accuracy head tracking system
- Provides a binocular display with a 40 degree, visor projected field of view
- Visor projection can include FLIR or video imagery
- Operational applications of navigation, target designation, and weapons aiming and firing
- Optimum center of gravity
- Custom fit helmet liner
- In production and service with 9 other countries



Weapons Systems

Rockets



Hellfire

20mm Turret Gun



Sidewinder

Rockets

The rocket system employed on the AH-1Z uses 2.75 inch (70mm) rockets. All available Mk66 rockets are supported with warheads of three general types; i.e. unitary, airburst cargo, and training warheads.

Either the LAU-68 (7 tube) or the LAU-61 (19 tube) launchers can be loaded onto any of the four universal wing store stations. Rocket arming, selection, fusing, and firing are controlled by hardware and software in the Weapons Processor and Integrated Stores Management System (ISMS).

There are two basic modes for arming and firing rockets:
·Continuously Computed Impact Point (**CCIP**) or Direct Mode

·Continuously Computed Release Point (**CCRP**) or Indirect Mode

The **CCIP** mode displays a rocket Fire Control Reticule (**FCR**) on the helmet visor ('virtual HUD') as calculated by the weapons processor. The **FCR** shows the predicted impact point of the rocket for a pilot-selected range. In this 'Direct' mode, the pilot steers the aircraft so that the **FCR** overlays the target as seen by the unaided eye. The pilot launches the rocket/s by a trigger squeeze, enabling single, pairs or salvo firing as commanded on the MFD.

The **CCRP** mode requires target tracking using the TSS or stored navigation waypoint or threat. The TSS is controlled by the mission grip, and provides laser range, relative angles to the target, and target velocity using angular rate measurements. TSS or navigation system information in conjunction with a target tracking function in the weapons processor enables the calculation of accurate target tracking solutions. The rocket ballistics function is then used to compute a vector aiming direction for the aircraft so as to hit the tracked target. In this **CCRP** mode, the pilot controlling the aircraft must steer the aircraft so that the displayed **FCR** is positioned over the HMSD Armament Datum Line (**ADL** centerline) symbol. At that point the pilot engages the trigger to launch the rocket/s. In an automatic mode, when pilot-enabled and with the trigger engaged, the rockets are automatically launched by the Weapons Processor when the **FCR** overlays the Fuselage Reference Line (**FRL**).

Airburst, Cargo, and Unitary Warheads:

- (1) M151 High Explosive-Fragmentation [HE-FRAG]
- (2) M229 HE-FRAG
- (3) M261 HE-Multipurpose Submunition [HE-MPSM]
- (4) M255A1 Flechette
- (5) M262 Illumination Flare
- (6) M264 Smoke[RP]

Hellfire

The AH-1Z is equipped with Hellfire missiles which have autonomous laser designation or Fire & Forget mode (with remote laser designation). Also, with the incorporation of M299 Hellfire launcher, the Longbow RF Hellfire missile can be provided as an **option**. The Hellfire Missile System (HMS) is capable of launching sixteen Hellfire missiles at targets designated by ground or other airborne units, or autonomously. This can be accomplished while the helicopter is at airspeeds from zero to Vne. The missile is a laser guided, point target weapon designed to destroy armored or reinforced targets. The Hellfire missile system is controlled by the Integrated Stores Management System (ISMS) function within the Integrated Avionics System. One HMS lightweight launcher is mounted on each ejector rack. Each launcher can carry up to four missiles. The launchers contain internal electronics and circuitry for interfacing with the IAS. Arming and firing the missiles are accomplished by the pilot or gunner through the HMS and wing stores armament system circuitry controls.

20mm Turret Gun

The A/A49E-7(V4) turret system is chin-mounted on the helicopter and provides the capability to position, feed, and fire the M197 20mm automatic gun.

Turret Modes of Operation. The turret system can be operated in one of three modes of operation from either crew station. The operator controls the turret system in FIXED, TS/GUN, or HMSD Mode. Turret and wing stores cannot be fired simultaneously.

Fixed Mode. In the FIXED mode of operation, the turret system remains stationary in a fixed forward position at 0° azimuth and adjustable elevation for range. The pilot aims the weapon by maneuvering the helicopter in such a manner as to superimpose the reticle image of the sight on the selected target. The gun is fired by pressing the TRIGGER switch on the cyclic grip.

HMSD Mode. In HMSD mode, movement and positioning of the turret system is controlled by the Helmet Mounted Sight Display (HMSD). Within azimuth and elevation limits of the system, the turret is positioned to the pilot Line Of Sight (LOS). That is, the gun barrels are aimed to the same point as the pilot helmet sight reticle, with ballistics corrections made by the fire control system based on manual range, temperature, and altitude. This mode is engaged by pressing the Action switch on the cyclic to slave the gun turret to the helmet. The gun is fired by pressing the Trigger Switch on the cyclic grip. If the operator is not in control of the cyclic grip TS, the Action switch and trigger on the mission grip may be used.

TSS/GUN Mode. In TSS/Gun mode, aiming of the turret is accomplished by superimposing the reticle image of the sight on a selected target. The operator may employ several methods of acquiring (ACQ) and tracking (TRK) targets with the sight. By placing ACQ/TRK/STOW switch to the TRK position, the sight may be directed to the desired target by using the track control on the mission grip. The quickest method, however, uses either the pilot or copilot HMSD to direct the sight for quick target acquisition. The pilot superimposes his HMSD

reticle on a target and the copilot directs the sight to that target by placing the ACQ/TRK/STOW switch on the mission grip to TRK and depressing the PHS ACQ button. The copilot may also direct the sight with his own HMSD by superimposing his reticle on the desired target and positioning the ACQ/TRK/STOW switch to ACQ. Once the target is acquired, the operator engages the Action switch to slave the gun to the Target Sight (TS) line-of-sight. A fire control solution will be calculated based on range, helicopter and target motion, wind, temperature, and pressure altitude to correct the gun position to engage the target.

The gun drive assembly rotates the gun barrels at a firing rate of approximately 650 rounds per minute. The ammunition feed system contains 750 rounds of belted 20mm ammunition. The gun is fired for the duration of the trigger command signal plus clearing cycle. The M197 automatic guns is restricted to a firing schedule not to exceed a 450 round burst with a minimum of 6 minutes cooling prior to firing the remaining 300 rounds.

Sidewinder

The AH-1Z is equipped with the AIM-9 Sidewinder air-to-air missile for fire and forget capability. The Sidewinder guided missile is a supersonic weapon with infrared target detection, and a solid propellant motor.



Rotor Systems

The high performance AH-1Z Main Rotor System represents a major breakthrough in technology. The simplicity of the AH-1Z main rotor design has eliminated all bearings, hinges, and bifilar or other type vibration dampers. The result is a highly maneuverable, fast, long-range Attack Helicopter.

- All-composite main rotor blades, yokes and cuffs provide very stable handling qualities and high cruise speeds

- 75% fewer parts than 4 blade articulated systems**

- Rotor hub weighs 15% less than conventional hubs

- Lower levels of vibration than any competing rotor systems

- Lower Life Cycle costs than any competing rotor systems

- Infinite life yoke and cuff

- Increased ballistic survivability

- Can sustain 23mm direct hit and continue to operate**

- Doubles the payload capabilities

- Semiautomatic blade fold for shipboard operations**

- Field camouflage

- Aircraft hangaring capabilities

- Reduces spare parts by 77%**

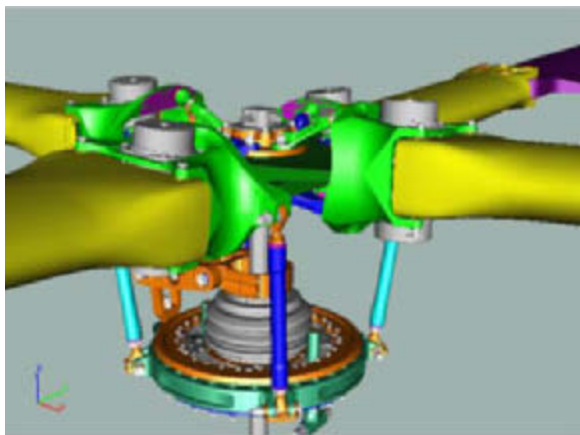

Main Rotor



The primary structural members of the main rotor hub consist of **two fiberglass yokes**. Each yoke is a multifunctional component which transmits torque from the mast to the blades, accommodates flapping, lead-lag, and pitch change motions, and retains the blades. A stacked yoke arrangement is chosen in lieu of one four-armed yoke. It permits the use of two identical stacked two arm yokes, which allows higher flapping angles and reduced manufacturing complexity. Logistics support problems are also reduced due to the smaller physical size of the two-armed yoke as compared to a single four-arm yoke. The **main rotor blade** is constructed primarily of composite materials (fiberglass / 8552 epoxy). The blade body consists of a spar assembly, leading edge protective strips, skins, honeycomb core, and trailing edge strip.

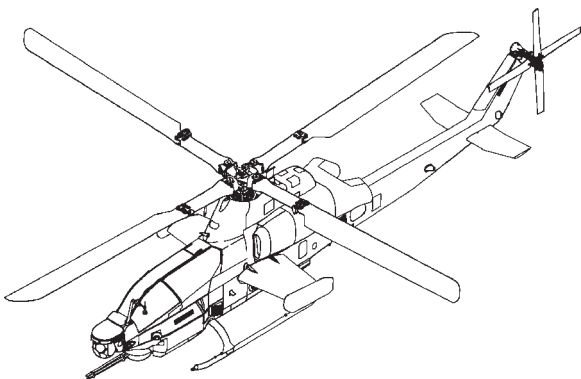

The **main rotor blades** incorporate a pilot-adjustable formation tip light on the upper surface. The rotor blades include forward and aft product balance pockets for spanwise and chordwise dynamic balance. The main rotor blade design includes adjustable trim tabs to facilitate tracking of the individual rotor blade. The main rotor blades are individually interchangeable and provide removable balance weights to ensure track and balance capability following field repairs. The main rotor blades have a design life objective of **10,000 hours**.



The blade leading edge is protected by a single piece **abrasion strip** made from stainless steel. The outer two-thirds of the strip is electroplated with nickel. An electroformed nickel tip cap is bonded to the blade tip to protect it from sand and rain erosion.

Tail Rotor

The Tail Rotor Assembly consists of two stacked, teetering rotors, independently mounted on a single output shaft using splined trunnions on the **pusher side** of the aircraft. Elastomeric bearings installed in the trunnion provide the load path for the drive torque and thrust loads, and provide for flapping motion.

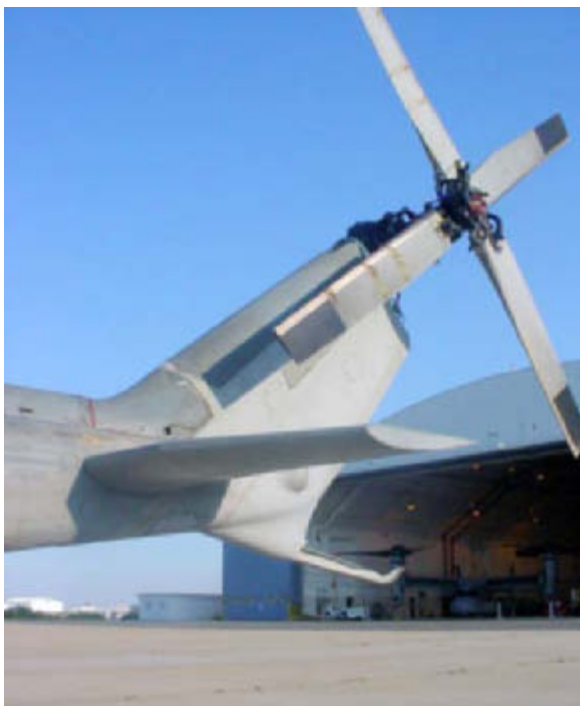

The Tail Rotor Hub consists of titanium yokes, elastomeric flapping bearings, shear restraints, and pitch horns. The hub assembly has a design life objective of **10,000 hours**. The blade leading edge is protected by a single piece **abrasion strip**. The outer part (approximately two-thirds) of the abrasion strip is electroplated with nickel.

Blade Folding

Blade folding is accomplished by a combination of automatic and manual means to lock out the blade pitch, position the blades for folding, disengage the blade pins, and rotate the blades for folding and spreading. Design of the blade pin powered lock and unlock mechanism prevents any possible motor backdrive situation. Safeties are provided to prevent the blade pin from disengaging in flight. The lockout and blade pin mechanisms are commanded by controls in the cockpit. Visual indication of the locked condition is also provided in the cockpit. An interlock system, independent of the cockpit indicator, prevents rotor start while the pins are in the unlocked condition. The ground crew is not required to climb atop the aircraft for the blade folding operation. Retracking or balancing of blades is not required after blade folding. Manual backups are provided for the automatic blade folding sequences in the event of failures of the automatic system. The system is capable of folding and unfolding the rotor blades in horizontal winds up to and including **45 kts** from any azimuth direction.



Shipboard Compatibility

The AH-1Z is capable of shipboard operations including takeoff, landing, refueling and rearming, and is securable for deck motions encountered up to sea-state 5. The AH-1Z has been designed for compact stowage of the assembled aircraft aboard ship and for spotting on the flight decks of the standard US Navy LHA, LHD, LPH, LPD, and LSD class ships. The AH-1Z is compatible with the elevators of the above class ships. The aircraft fits on the deck edge (50' X 34') and stern (60' X 35') elevators of the LHA, and starboard and port (50' X 40') elevators of the LHD. A minimum of 18 inch clearance between the aircraft and the ship's structure is maintained while the elevator is in transit and at the hangar deck level (Overhanging the unencumbered sides of elevators is permitted).



Propulsion System

Widely acknowledged for their proven reliability and low fuel consumption, the modular designed T700 series engine, two of which power the AH-1Z and UH-1Y, also power both the Bell AH-1W and 214ST, as well as the UH-60 Blackhawk and other US Government and International aircraft. The T700 engine has an integral particle separator, a self-contained lubrication system that uses fuel flow to cool the engine oil, and an integral history recorder. Only **ten tools** are required to perform field maintenance. With over 19 million service hours accumulated on 10,000 T700/CT7 engine variants in service, this engine is mature and has already earned an enviable reputation for reliability. The **T700-GE-401** engine is the most fuel efficient engine in hot day, high altitude performance.

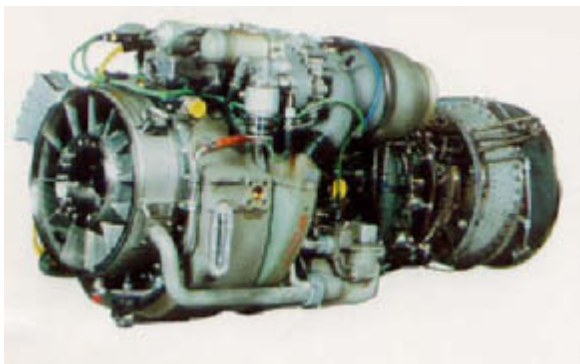

The installed rated **Contingency Power** [2.5 minute OEI] for the T700-GE-401 engine is 1723 SHP (for a sea level standard day).

The installed rated **Intermediate Power** [Twin Engine, 30 minute rating] for the T700-GE-401 engine is 1690 SHP (for a sea level standard day).

The installed rated **Maximum Continuous Power** [Twin Engine, continuous rating] for the T700-GE-401 engine is 1437 SHP (for a sea level standard day).

The T700-GE-401 engines have an **emergency lubrication system** to allow operation after damage that totally interrupts the normal supply of oil. The Accessory Gear Box [AGB] and C-sump components can continue to operate at least six minutes with

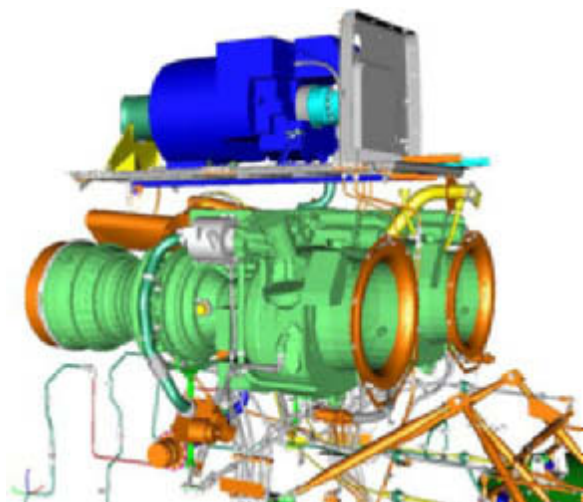

residual oil present. The engine specification requirement is that the engine shall operate at intermediate power for a period of 30 seconds during which no oil is supplied to the engine oil pump inlet. As a result of this operation, there shall be no detrimental effects to the engine during the oil flow interruption period or during engine operation thereafter.

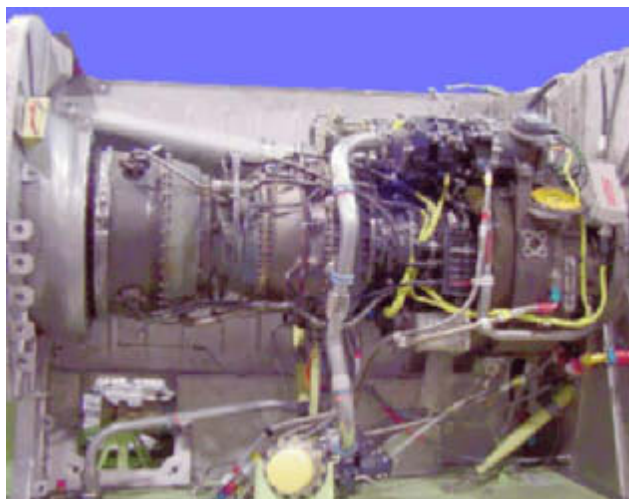

Particle Separator & Engine Systems

The T700 engine has a unique inlet **particle separator** integrated into the forward main engine frames. The fully anti-iced separator provides a high level of compressor protection against damage from foreign objects such as sand, dust, birds, and ice. The separator imparts a swirl to the entering airflow and directs that part of the flow containing the centrifuged sand and foreign material through a scavenge system energized by a mechanically driven blower. The clean air is then deswirled before entering the engine core.

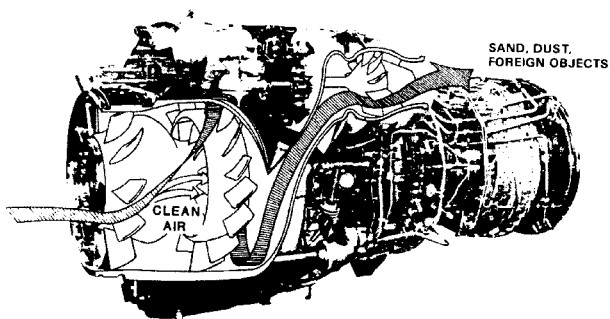

Engine **compressor cleaning** provisions include the necessary plumbing required to interface to the fresh water wash spray ring. The installation is a permanently installed system, which permits simple and rapid connection of standard United States Navy wash carts. An alternate fitting could be used if need to mate with other desired wash carts.

Automatic **engine overspeed protection** is provided via the engine controls, which are supplied with the engine from the manufacturer (General Electric). Bell Helicopter provides independent test circuits for each engine's overspeed protection system in the engine's electrical control units. Two test buttons for each engine (total of at least four) are in the cockpit at a location that is easily accessible to the pilot and copilot.

A **fire extinguishing system** is provided for the engine bay and APU compartments.

A **Hover Infrared Suppression System (HIRSS)** is an integral part of the exhaust system and uses engine compartment and external air for cooling. The HIRSS is self-powered and nonselectable. The HIRSS is designed/sized for the worst-case temperature and airflows of the T700-GE-401.

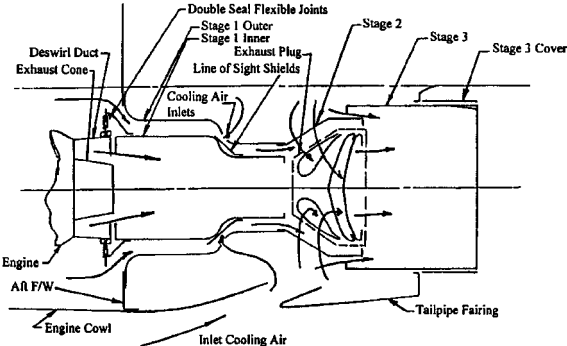

Hover Infrared Suppression System



Hydraulic Systems

The hydraulic subsystem consists of two Primary Flight Control Systems (PC-1 and PC-2), one rotor brake, and one rotor blade fold system. Operating pressure is 3000 psi. PC-1 and PC-2 systems power the three main rotor actuators and the one directional actuator of the flight control system. Each actuator is of dual cylinder design. One cylinder of each actuator is operated by PC-1 and the other cylinder is operated by PC-2. Both PC-1 and PC-2 systems include a transmission driven hydraulic pump, bootstrap (pressurized) reservoir, filter module, flight control actuators, integral Stability and Control Augmentation System (SCAS), oil cooler fan hydraulic motor, and other required components and connection lines. In addition PC-1 includes a rotor brake control unit.

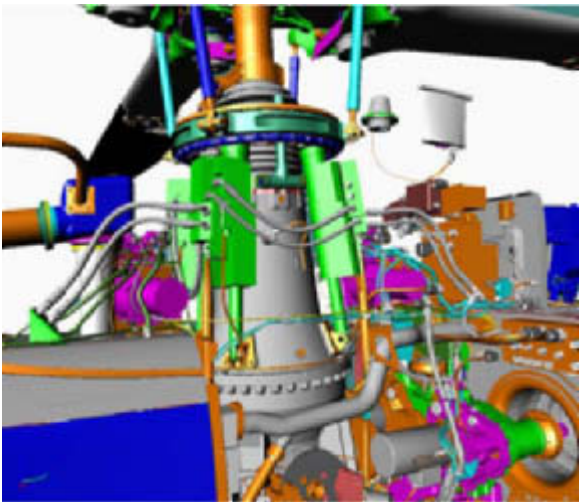

Hydraulic Schematic

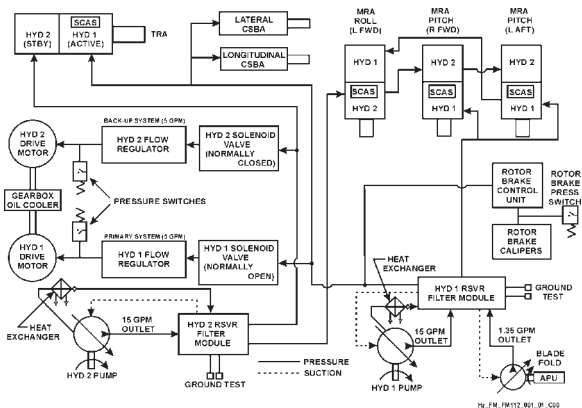

Pneumatic Subsystem

Main engine starting is accomplished by first starting the **auxiliary power unit (APU)** which subsequently pressurizes the pneumatic manifold with APU bleed air. A start control valve and air turbine starter are provided for each engine. Opening the start control valve initiates the starting sequence by allowing compressed air from the manifold to drive the starter, thus turning over the engine through the engine start cycle.

A ground connection valve is provided in the pneumatic manifold to allow connection of a hose for pressurized air from a ground cart or from another aircraft pneumatic system.

The pneumatic system also supplies compressed air for air conditioner operation, windshield rain removal, and On Board Inert Gas Generating System (OBIGGS) for fuel tank inertion. Shutoff valves are also provided for these functions.

Electrical Systems

The primary **DC generating system** consists of two **400 ampere** brushless 28 VDC generators driven from the combining gearbox, with each generator controlled by a generator control unit. The generator control units provide voltage regulation and protection from MIL-STD-704 exceedances and ground faults. No load shedding or reduction in mission capability is required, should loss of a single DC generator occur.

The aircraft **AC power system** consists of two 1500 VA three phase inverters. The AC power distribution system accommodates load shedding for emergency power.

Sundstrand Auxiliary Power Unit



The **APU driven DC generator** is a **200 ampere** brushless 28 VDC generator capable of powering all buses. Although not all aircraft equipment may be operated simultaneously, sufficient power shall be available so that all equipment may be systematically operated and functionally checked, including the 20 mm gun turret. The APU generator also provides battery charging during this time. The APU is capable of starting on aircraft battery power when cold soaked at a temperature down to **-26°C (-15°F)**. The APU may be started from a 28 VDC external power source down to **-54°C (-65°F)**. Electrical power for APU starting may be furnished by an external power cart, from the primary generators when at least one engine is operating, or by the onboard battery.

The AH-1Z's **battery** is a 19 cell Nickel-Cadmium low maintenance type providing a minimum of **25 amp/hours**. The battery is capable of providing starting and emergency power requirements for a minimum of 1 year without maintenance action. The battery is capable of providing sole power for operation of essential equipment for emergency operation for a minimum of at least **20 minutes**. Battery location is in the aft left-hand side of the ammunition bay.

Electric Power Schematics

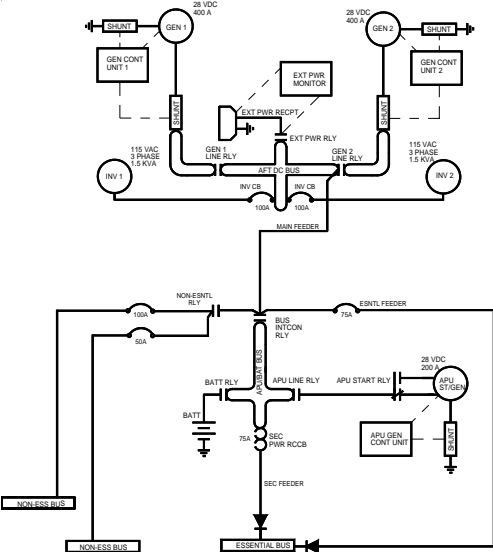
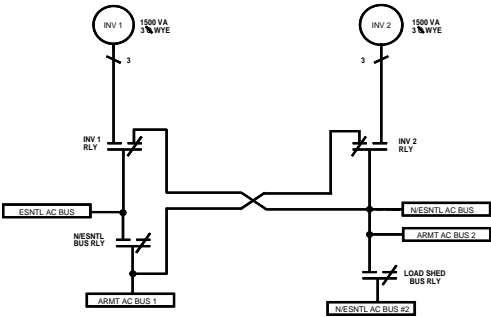
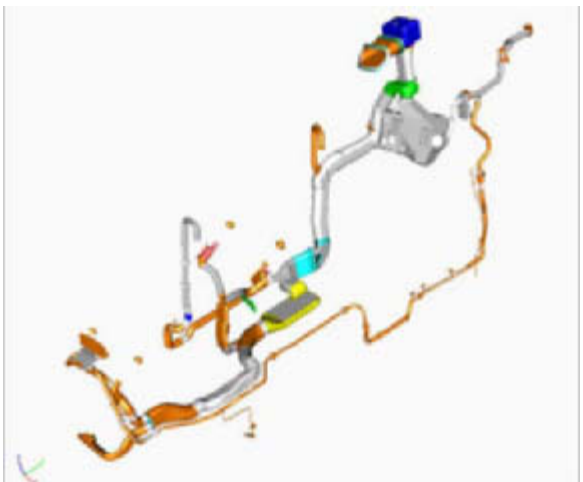
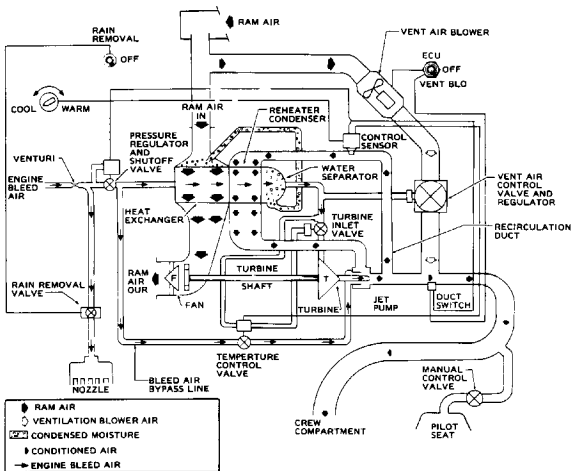

Figure 1. Electrical DC Power System



Environmental System

The environmental control system (ECS) consists of the equipment to regulate temperature and humidity of incoming air. The incoming air is distributed to the pilot and gunner through suitable ducting to the crew compartments. Engine bleed air provides the supply air as well as the power source for the environmental control system.



Fuel System

The fuel system includes crashworthy self-sealing fuel cells with interconnect lines connecting the cells. The system has firewall shutoff valves, low level switches, fuel feed line check valves, boost pump pressure switches, fuel quantity transmitters and indicator, fuel cell interconnect valve, fittings, and connecting lines. All fuel system components have an operational life equal to or greater than the weapons platform. The fuel system is compatible with fuels **JP-4, JP-5, JP-8 and Jet A**. The system is equipped for either **gravity** or **pressure** refueling. The refueling receptacle is on the starboard side of the aircraft. Each fuselage cell contains a sump, drain valve and a submerged fuel boost (prime) pump.

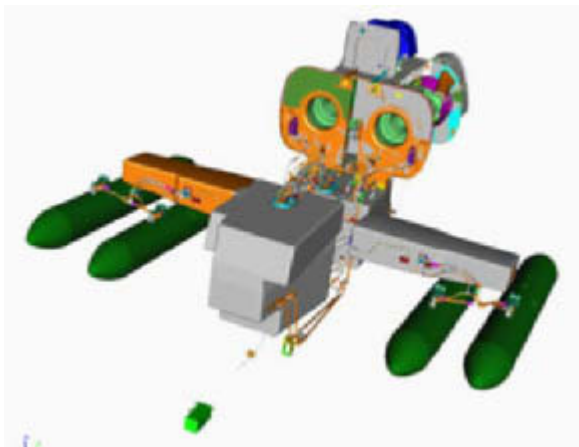

The fuel system consists of four interconnected fuel cells, two in the fuselage and one in each weapons pylon. The internal forward fuselage cell has a usable fuel capacity of **706 liters (186.3 gallons)** and the aft internal fuselage cell has a usable fuel capacity of **468.8 liters (123.7 gallons)**. Each weapons pylon contains a fuel cell with a usable fuel capacity of **193.3 liters (51 gallons)**. This equates to a total usable internal fuel capacity of **1561.4 liters (412 gallons)**. The system is designed such that either or both power sections can operate from either or both fuselage fuel cells.

Both fuel cells have low level caution switches which transmit a signal to caution panels when fuel in the tank reaches a low level. The caution indicates that approximately 30 minutes of fuel remain. The pressure fueling system accepts the standard pressure refueling probe (MS29520). Fuel flow to cells has a maximum rate of 90 gpm at 60 psi nozzle pressure. The system consists of a pressure fueling valve located in the right side of the aft fuel cell, a dual pilot valve in the forward cell, and a dual shutoff valve.



Complete provisions are provided to install and carry three different size external **auxiliary fuel tanks** on wing pylon stations 2, 3, 4, and 5. The current auxiliary tanks have capacities of **292 liters (77 gallons)**. This allows for up to **1168 liters (308 gallons)** of additional fuel to be carried along with the **1561.4 liters (412 gallons)** of internal fuel. Growth potential exists to increase total auxiliary fuel capacity to **3483 liters (920 gallons)** with 4X230 gal tanks.

AH-1Z * PERFORMANCE

| | Kilograms | Pounds |
|------------------------|---|---|
| Empty Weight | 5591 | 12,300 |
| Max Useful Load | 2620 | 5,764 |
| Max Internal Fuel | 1258 | 2,858 |
| Max Gross Weight | 8409 | 18,500 |
| HOGE High/Hot Wt | 7682 | 16,900 |
| Payload (Hot Day) | 1260 | 2,176 |
| | @176 km Radius | @110 nm Radius |
| LRC Speed | 248 km/hr | 134 kts |
| MCP Speed | 287 km/hr | 155 kts |
| Dive Speed | 411 km/hr | 222 kts |
| Max Endurance, hours | 3.3 | 3.3 |
| Max Rate of Climb | 14.2 M/S | 2790 ft/min |
| Vertical Rate of Climb | 9.7 M/S | 1907 ft/min |
| OEI Rate of Climb | 5.5 M/S | 1074 ft/min |
| Service Ceiling | 6096+ M | 20,000+ ft |
| Max Crosswind | 65 km/hr min, 93 km/hr max | 35 kts min, 50 kts max |
| Weapons Stations | 6 Wing Stations 4 Universal 16 PGMS | 6 Wing Stations 4 Universal 16 PGMS |
| Maneuverability, g's | -0.5 TO +2.8 | -0.5 TO +2.8 |
| Mission Radius | 208 km w/1150 Kg Payload | 125 nm w/2,500 lb Payload |

*** Aircraft configured with T-701-GE-401 engines in Anti-Armor mission profile.**

USMC Baseline Configuration

AIRCRAFT

Airframe

Composite/Aluminum alloy fuselage
Plexiglass Canopy
Environmental Control System
Skid Type Landing Gear
Shipboard Capable Tie Down Fittings
Semi-Monocoque Tailboom and Vertical Fin

Rotors & Controls

Composite Rigid Bearingless Rotor Heads
4 Bladed Composite Main Rotor Blades
4 Bladed Composite Tail Rotor Blades
Semi Automatic Main Rotor Blade Fold System
Digital 4 Axis Automatic Flight Control System

Transmission/Drive System

5,000 Hour TBO Design Goal/10,000 Hour Service Life Drive System
Aluminum Cases

Power Plants

Two General Electric T-700-GE-401 engines
Sundstrand Auxiliary Power Unit

COMMUNICATIONS

Dual VHF/UHF AN/ARC-210 Radios with Embedded KY-58
Telephonics C-11746B(V)3/ARC Intercom units (2)

NAVIGATION

CN-1689(V2)/ASN Embedded GPS/INS
ARN-153 TACAN System
DF-301E VHF/UHF Direction Finder

IDENTIFICATION FRIEND OR FOE (IFF)

AN/APX-100(V) IFF

COUNTERMEASURES GROUP

AN/ALE-47 Countermeasures System
AN/APR-39A(V)2 Radar Warning Set
AN/AAR-47(V)2 Combined Missile Warning/Laser Warning Set

SURVIVABILITY

23mm Tolerant Rotor Hub and Blades
Large Diameter Control Tubes for Tolerance Against Small Arms Fire
12 FT/Second Sink Speed Landing Gear
Crashworthy, Self-Sealing Fuel Cells
On Board Inert Gas Generating System (OBIGGS)
Engine IR Suppressors
Stealthy Design Inherent with Low Profile Silhouette
Low IR Reflective Paint
Variable Capacity Energy Attenuating Crew Seats

MARINIZATION

Simple Semi Automatic Blade Fold
Corrosion Resistant Design
Wet Lay-up Manufacturing Process
30 Degree Turn Over Angle
EMI Shielded/Meets 200 V/Meter Requirement
Marinized Engines

INTEGRATED AVIONICS SYSTEM (IAS)

Mission Computers (2)
6" x 8" Liquid Crystal Multi Function Displays (4)
4.2" x 4.2" Liquid Crystal Dual Function Displays (2)
Keyboard Units (2)
Standby Attitude Sensor
Air Data Computer
Stores Station Electronics
Station Control Unit

DIGITAL MAP SYSTEM (TAMMAC)

Advanced Memory Unit (AMU) Mission Data Loader
Digital Map System (DMS)

ELECTRICAL

DC Generators (2)
AC Inverters (3)
Ultra Low Maintenance Ni-Cad Battery
Integrated Flat Wiring

ARMAMENT

16 Hellfire Missiles
6 AIM-9 Sidewinder Air-to-Air Missiles
20mm Gun with 750 Rounds
2.75" Rocket Pods (7 or 19 Shot)

SENSORS

Lockheed Martin AN/AAQ-30 Hawkeye Target Sight System (TSS)
THALES *TopOwl* Helmet Mounted Sight and Display (HMD) System

MISCELLANEOUS

Flight Control Computer
TEAC V-80AB-F VCR
Mission Grips (2)
Low Airspeed Air Data System (LAADS)
BF Goodrich IMD HUMS
77 Gallon Aux Fuel Tanks

Survivability Features

The AH-1Z is the most survivable attack helicopter in the world. Its design includes vulnerability reduction, susceptibility reduction, and crashworthiness. Standard AH-1Z survivability equipment includes the Hover Infrared Suppressor System (HIRSS) for the engine exhausts, Radar Warning Receiver, Countermeasure Dispensers, Laser Warning System, and Missile Warning Set. The small silhouette and shape of the AH-1Z as well as low IR reflective paint greatly contributes to the survivability of the aircraft. The fuel system is ballistically tolerant with built in fire suppression and internal (integral), self-sealing, crashworthy tanks in the weapons pylons that increase fuel capacity for extended mission range.

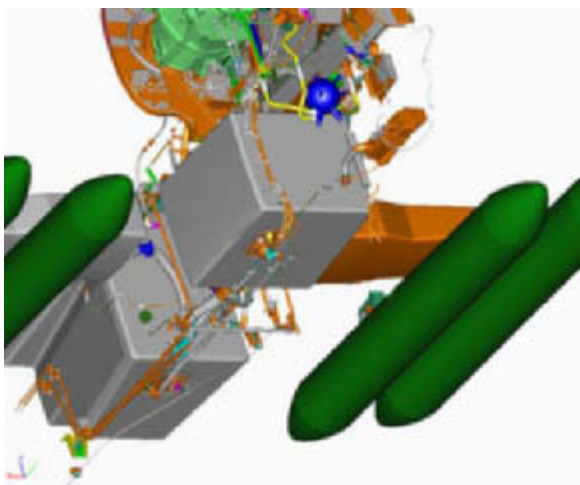

The fuel cells are crashworthy and provide self-sealing protection up to 0.50 caliber on all wetted surfaces. The cells are made of increased strength material and have integral fittings, which are designed to fail at a load greater than that required to fail the cell material. The fuel cells provide overall ballistic protection to 0.50 caliber. A bulkhead is provided between the cells and the crew position to prevent injury to personnel due to dislodging of the fuselage fuel cell in case of a crash. The secondary cells are located in the forward area of each wing.



The small silhouette and shape of the AH-1Z as well as low IR reflective paint contributes to minimize detection and acquisition by greatly reducing the signature of aircraft. The low glint canopy minimizes light reflection and hard coated inner surfaces provide superior abrasion resistance. Engine exhaust IR suppression is provided via state-of-the-art suppressors integral to the engine exhaust. The design of the AH-1Z provides reduced visual, acoustic, and infrared signatures, and radar cross-section.



H-1 Program Description

The AH-1Z is one of two new aircraft being developed for the United States Marine Corps (USMC). The other aircraft is the UH-1Y, a general-purpose utility aircraft. Together, these two aircraft comprise the H-1 Program. The AH-1Z and UH-1Y share a common tailboom, engines, rotor system, drive train, avionics architecture, software, controls and displays – greatly reducing the manufacturing/procurement costs for both the US and participating allies. **The enormous commonality between the AH-1Z and UH-1Y (over 84% identical components) results in savings of at least \$3B in operating and support costs over 30 years for the USMC.** This AH-1Z and UH-1Y “identity” dramatically reduce strategic lift requirements and greatly improves the opportunities for successful coalition warfare.



Bell Helicopter will remanufacture USMC AH-1W aircraft into zero time AH-1Z attack helicopters and UH-1N aircraft into a modern, high performance utility aircraft called the UH-1Y. Both aircraft will receive dramatic increases in range, payload, and speed. The very high level of common components shared between the two aircraft will facilitate a significant reduction in spare parts inventory, number of maintenance personnel required, simplify training for pilots and maintenance personnel, simplify deployment operations, and virtually provides two new aircraft for the price of one.

UH-1Y – AH-1Z Commonality



For international customers who currently operate either the AH-1W or UH-1 series aircraft, the opportunity exists for benefiting from a similar remanufacturing program. Totally new manufactured aircraft will also be offered.

Optional Equipment

Longbow International, Inc., Cobra Radar System (CRS)

The Cobra Radar System improves survivability and lethality of the AH-1Z aircraft by providing: enhanced situational awareness, rapid-response timelines, fire-and-forget missile delivery, and adverse weather capability.

The system is based on Longbow heritage radar technology adapted for use in a wingtip or stores mounted pod. Composed of a pod based radar mounted on a wingtip (AH-1Z) or stores position (for earlier Cobra configurations), CRS is inherently compatible with the AGM-114L Longbow Hellfire fire-and-forget missile and the M-299 Launcher.



Pod mounting significantly reduces cost, simplifies maintenance, and permits rapid transfer of the pod from one aircraft to another. Appropriate tactics compensate for the fuselage restriction on field of regard. The CRS is fully integrated with the AH-1Z aircraft.

The CRS automatically searches, detects, locates, classifies, highest priority targets, then prioritizes multiple moving and stationary targets on land and in the air while operating in adverse weather and battlefield obscurants. Target location is available for use by other onboard sensors, for transmission to other aircraft and command and control centers, and/or for fire-and-forget engagement with the AGM-114L. The radar's automatic rapid search capability significantly adds to the operator's situational awareness and survivability. The CRS is also capable against littoral targets that are detected and displayed on the map display.

System Operating Parameters

| | |
|-----------------------------|--|
| Frequency | Millimeter wave |
| Range | Moving 8 km, stationary 4 km |
| Weight | 200 lb |
| Operating Modes | Ground surveillance & targeting, air surveillance & targeting, navigation & obstacle avoidance |
| Features | Automatic detection, location, classification, & prioritization of over 100 tactical targets |
| Operating Conditions | Clear day, night, smoke, fog, dust, rain, snow, & countermeasures |



CRS Cockpit Displays

The cockpit displays (below) show this integration in action. In the display on the left, the CRS target icons are rapidly displayed over the moving map display with automatic prioritization (a circle over the highest priority target and a square over the second). The display on the right shows the TSS electro-optical system image, which is automatically cued to the highest priority target. The process is extremely fast, allowing the AH-1Z to engage a target before the enemy target can engage it.



The display below illustrates the navigation and obstacle avoidance mode in which black triangles represent obstacles the pilot is to observe and avoid. In this mode, the display also shows shading to indicate the altitude of the ground relative to the aircraft.



Optional Equipment

AN/ALQ-211 Suite of Integrated RF Countermeasures

ITT Industries

The AN/ALQ-211 provides enhanced situation awareness, advanced survivability suite solutions, and integration with other aircraft sensors.



Key Features

- Scalable, Modular
- Identifies and Responds to RF Threats
- 360 Degree Protection
- Full-Spectrum Protection
- Situation Awareness
- Electronic Support Measures
- RF Countermeasures
- Threat Warning
- Sensor Fusion
- Data Recording for Post Flight Analysis
- Embedded Training

ALQ-211 Incorporates EW Controller Capability to Integrate All Elements of Electronic Warfare

- Missile Warning
- Laser Warning
- IR Countermeasures
- Countermeasures Dispensing
- RF Warning and Countermeasures

ALQ-211 Key Functions: Pre-Mission Planning

Preflight, the ALQ-211 allows aircrews to download local order of battle threat information for effective mission execution. This mission planning capability is matched with on-board, real-time links to other intelligence systems to provide access to an up-to-date threat lay-down.

Threat Identification & Warning

The ALQ-211's receiver and advanced threat identification processing provide accurate threat identification, mode, and location beyond the lethal threat range. This is accomplished through passive sensing of the entire external RF environment. The ALQ-211 fuses RF, IR, and Laser threat data for complete, multispectral threat awareness.



The ALQ-211 Provides Improved Situation Awareness
for Aircraft Survivability and Mission Success

Situation Awareness

The ALQ-211 manages multi spectral fusion for RF, IR, and laser warning. Data is also presented in a dedicated cockpit display that provides immediate notification of potential and eminent threat engagements, along with threat range from the mission aircraft. Threat data is presented on a digital terrain map for real time mission replanning to exploit terrain masking, avoid detection and navigate away from the threat kill area. The ALQ-211 displays own ship position, route of flight, threat locations, lethality zones, and threat intervisibilities for terrain masking for comprehensive total battlefield awareness. Data can be transmitted off-board for threat targeting. It can also be transmitted both horizontally and vertically allowing other aircraft and ground commanders to increase situation awareness of the true battlefield.

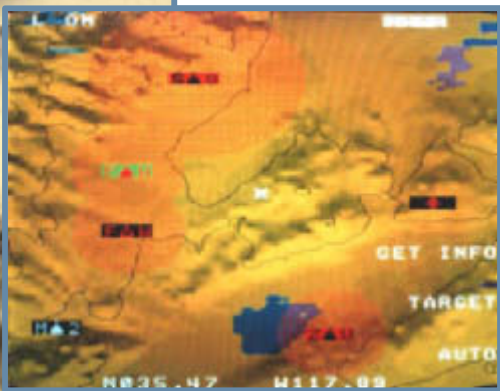

Active Countermeasures

The ALQ-211 provides protection against all classes or RF guided weapons to include Pulse, Pulse Doppler, Continuous Wave and Monopulse Radar threat systems. The ALQ-211 also incorporates the capability to act as the aircraft's survivability suite controller. If a threat is unavoidable and classified as immediately lethal, the ALQ-211 can initiate an integrated, instantaneous response for RF, IR, and expendables as required; providing an integrated, multispectral approach for aircraft self-protection.





**P.O.Box 482, Fort Worth, Texas 76101
Phone: (817)280-2800**

**An Adobe Acrobat PDF
version of this booklet is
available for download from
the Bell Helicopter Textron
product information website**

www.bellhelicopter.com



FLY SMART. FLY BELL.



Bell Helicopter Textron Inc.
P.O. Box 482, Fort Worth, TX 76101
Phone: (817) 280-2800
www.bellhelicopter.com

©2006 Bell Helicopter Textron Inc., all rights reserved. The data set forth in this brochure are general in nature and may vary with conditions. The photographs and drawings appearing herein are for illustration only, and may differ from the actual aircraft. For performance data and operating limitations for any specific flight mission reference must be made to the approved flight manual.

Printed in USA - March 2006