

Kaman K-1200



FAA Approved Rotorcraft Flight Manual

FAA approved in normal category based on FAR 21 and FAR 27. This flight manual includes the material required to be furnished to the pilot by FAR 21 and FAR 27. This flight manual must be carried in the helicopter at all times.

Helicopter Serial No. _____



Helicopter Registration No. _____

Sections 2, 3, 4, 5, and 6 of this manual have been approved by the Federal Aviation Administration.

This manual is a complete baseline revision of all previous Kaman K-1200 FAA Approved Rotorcraft Flight Manuals.

FAA approval by:

Manager, Boston Aircraft Certification Office
Federal Aviation Administration



FAA approval date: August 30, 1994
Baseline Revision Issue February 17, 2004

Kaman Aerospace Corporation
Bloomfield, Connecticut USA

List of Effective Pages

All pages required to make this handbook complete are listed in this section, along with the current revision number of each page. A revision number “0” indicates a page from the basic issue, original and unrevised. When a revision is issued against this handbook, insert the changed pages and remove superseded pages. Revisions to text are indicated by a revision bar at the outside edge of the page, next to the text affected. Revisions to figures are indicated by a hand pointing to the revised area for minor changes or by a revision bar if the revision is a major portion of the figure. This section contains a list of the revisions and issue dates.

Sections 2, 3, 4, 5 and 6 of this manual have been approved by the Federal Aviation Administration. Pages corresponding to these sections in the below list of effective pages are FAA approved pages, and the current revision number next to each page or group of pages is FAA approved. Refer to the List of Revisions (LOR) section of this manual for details of each manual revision.

List of Revisions

Baseline Revision February 17, 2004

List of Effective Pages

| <u>Page</u> | <u>Rev. No.</u> | <u>Page</u> | <u>Rev. No.</u> |
|---------------------------|-----------------|--------------------------|-----------------|
| Title | 0 | 4-1 through 18 | 0 |
| LEP-1 | 0 | 5-1 through 17 | 0 |
| LEP-2 blank | 0 | 5-18 blank | 0 |
| TOC-1 through TOC-3 | 0 | 6-1 through 6-5 | 0 |
| TOC-4 blank | 0 | 6-6 blank | 0 |
| 1-1 through 11 | 0 | 7-1 through 7-12 | 0 |
| 1-12 blank | 0 | 8-1 through 8-34 | 0 |
| 2-1 through 22 | 0 | 9-1 through 9-8 | 0 |
| 3-1 through 19 | 0 | 10-1 through 10-19 | 0 |
| 3-20 blank | 0 | 10-20 blank | 0 |

LEP-1/(LEP-2 blank)
February 17, 2004

Kaman K-1200
Rotorcraft Flight Manual

Log of Revisions

| Rev. No. | Revised Pages | Purpose | Date | FAA Approval |
|------------------------------------------------------------------------------------------------|---------------|---------|------|--------------|
| | | | | |
| There are no revisions to the current K-1200 rotorcraft flight manual dated February 17, 2004. | | | | |

Section 1 General Information

Contents

| | |
|---------------------------------------|------|
| About this manual | 1-2 |
| Aircraft description | 1-3 |
| Descriptive data | |
| Aircraft dimensions | 1-3 |
| Rotor system | 1-4 |
| Drive system | 1-4 |
| Powerplant | 1-4 |
| Fuel system | 1-4 |
| Oil systems | 1-4 |
| Hydraulic system (if installed) | 1-6 |
| Landing gear | 1-6 |
| Electrical system | 1-6 |
| Abbreviations and definitions | 1-6 |
| Conversion tables | 1-10 |
| Metric to English conversion | 1-10 |
| English to metric conversion | 1-10 |
| Temperature conversion | 1-11 |

About This Manual

This rotorcraft flight manual is designed as an operating guide for the pilot. It includes the material required to be furnished to the pilot by FAR 21 and FAR 27. It also contains supplemental data supplied by the helicopter manufacturer.

This flight manual is not designed as a substitute for adequate and competent flight instruction or for knowledge of current airworthiness directives, applicable federal air regulations, and advisory circulars. Nor is it intended to be a guide for basic flight instruction or a training manual. It should not be used for operational purposes unless kept in a current status.

Helicopter airworthiness is the responsibility of the pilot. The pilot is also responsible for operating within the parameters of this flight manual.

This flight manual is divided into three numbered parts and ten numbered sections. Part one consists of section 1 – general data. Part two consists of FAA approved sections 2 through 6, including limitations, normal and emergency procedures, performance data, and optional equipment. Part three consists of sections 7 through 10, including weight and balance, system descriptions, handling and servicing data, and supplemental information.

This manual contains numerous warnings, cautions, and notes. The definition of these terms is as follows:

WARNING

An operating procedure, practice, or condition, etc., which may result in injury or death if not carefully observed or followed.

CAUTION

An operating procedure, practice, or condition, etc., which may result in damage to equipment if not carefully observed or followed.

NOTE

An operating procedure, or condition, etc., which is essential to emphasize.

Aircraft Description

The K-1200, Figure 1-1, is built specifically for repetitive lifting operations. The simplified design uses traditional aircraft materials engineered for maximum load bearing strength.

The single-seat configuration offers maximum pilot visibility in all directions. Controls and instruments are arranged to be compatible with vertical reference flight requirements. The pilot's seat is a high-energy absorbing unit supported by reinforced structure.

The K-1200 has twin, intermeshing, two-bladed rotor assemblies mounted side-by-side on individual rotor pylons. The rotors are driven by twin shafts of a single transmission. Synchronous intermeshing, with blades held 90 degrees out of phase, is maintained by the gear train within the transmission.

The rotor control system utilizes servo flaps: controllable airfoils mounted on the trailing edge of each blade. The servo flaps control the pitch of each blade and are themselves controlled by the pilot's collective pitch lever, cyclic stick and directional pedals. Auxiliary flight systems include rudders and stabilizers.

The K-1200 is powered by a single Honeywell T5317A-1 turbine engine rated at 1,500 SHP mechanically and 1,800 SHP thermally. The aircraft requires a maximum of only 1,350 SHP. The engine includes its own lubrication, cooling, pressurization, anti-icing, fuel, electrical, air bleed, and variable inlet guide vane systems. The fuel delivery system includes externally serviceable cartridge-type boost pumps and an external refueling receptacle.

The wheeled landing gear is equipped with high-energy absorbing struts and auxiliary landing gear (wheel skids) for soft terrain landings. The nose wheel can be swiveled through 360 degrees and can be locked in the forward position.

Descriptive Data

Aircraft Dimensions

| | |
|---------------------------|-----------------------|
| fuselage length | 41 ft. 9 in. (12.7 m) |
| fuselage height | 13 ft. 7 in. (4.1 m) |
| fuselage width | 12 ft. 7 in. (3.8 m) |
| parked length | 45 ft. 0 in. (13.7 m) |
| operating length | 52 ft. 0 in. (15.8 m) |
| parked width | 37 ft. 6 in. (11.4 m) |
| operating width | 51 ft. 5 in. (15.7 m) |
| blade tip height (static) | 8 ft. 3 in. (2.5 m) |
| disc diameter (each) | 48 ft. 4 in. (14.7 m) |
| servo flap length | 34.5 in. (87.6 cm) |

Rotor System

| | |
|--------------------|-------------------------------------------------------------------------------------------------------------|
| number of rotors | 2 |
| number of blades | 4 |
| articulation | Semi-articulated system; hubs free to teeter; blades free to lead-lag; friction dampers between blade pairs |
| servo flap control | Rigid pushrods within blade cavities; direct link to flight control system |
| rotor phasing | Maintained by transmission |
| in-flight tracking | Electro-mechanical by actuators and linkage on each rotor; pilot controllable |
| blade folding | Blades fold to fore/aft configuration |

Drive System

| | |
|--------------------|--------------------------------------------------------------|
| gearbox input | Rigid driveshaft with KAflex flexible couplings at both ends |
| rotor shaft input | Bevel cut gears with 24.3:1 reduction ratio |
| overrunning clutch | Sprag type |

Powerplant

| | |
|--------------------|---------------------------------------------------------------------|
| model | Honeywell T5317A-1 |
| type | Gas turbine with two stage gas generator and two stage free turbine |
| maximum engine SHP | 1,500 |
| maximum K-1200 SHP | 1,350 |
| maximum torque | 58 PSI @ 104% rotor speed (270 RPM) |

Fuel System

| | |
|-------------------|-----------------------|
| capacity (total) | 228.5 gal (865 l) |
| capacity (usable) | 219.5 gal (831 l) |
| approved fuels | See page 2-5 and 10-3 |

Oil Systems

| | |
|----------------------------|-------------------------------------------------------------------------------------------------------------------------------------------------------------|
| engine tank capacity | 3.21 gal (12.1 l) |
| approved engine oils | Must conform to either MIL-L-7808 or MIL-L-23699. See Section 10 or the Honeywell T5317A-1 operator's manual for additional engine lubrication information. |
| transmission tank capacity | 3.21 gal (12.1 l) |
| approved transmission oils | Dexron II, Dexron III |

Kaman K-1200
Rotorcraft Flight Manual

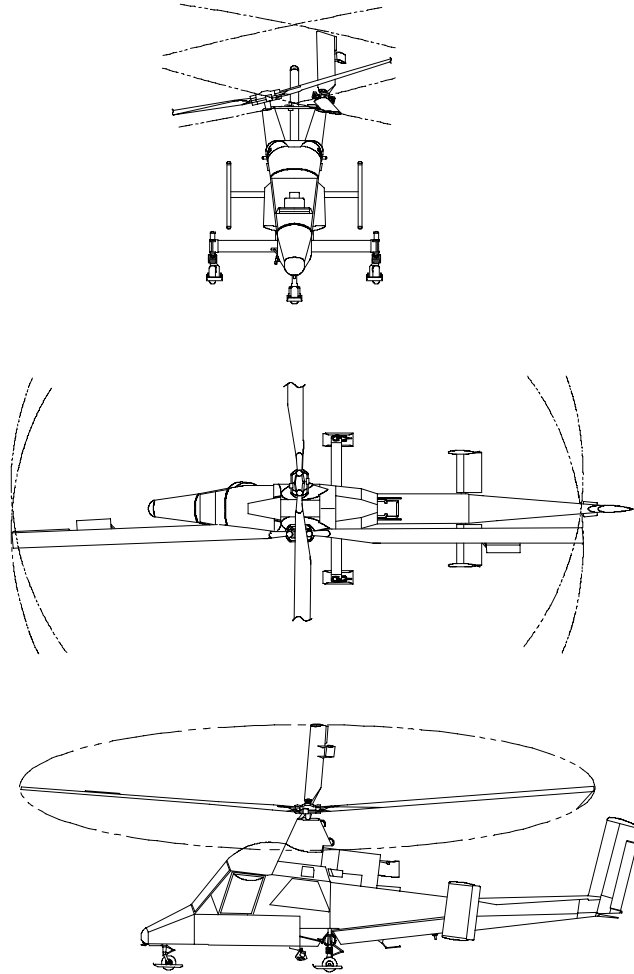

Figure 1-1. Kaman K-1200

Hydraulic System (if installed)

tank capacity 3.21 gal (12.1 l)
approved oil Must conform to MIL-H-83282

Landing Gear

main Fixed, with air-oil shock struts and auxiliary skid
nose Fixed, with air-oil shock strut and auxiliary skid; can be swivelled 360 ° and locked in forward position
brake system Hydraulic 9-piston caliper on each main wheel; auxiliary (parking) brake valve with cockpit control

Electrical System

type DC
voltage 28
battery (primary) Teledyne-Gill G6381E; 24 vdc; 43 amp/hour
battery/power supply (standby) B.F. Goodrich PS835D; 28 vdc; 5 amp/hour (if installed)
starter-generator Lucas Aerospace 23064-001; 9 Kw/H

Abbreviations and Definitions

arm Horizontal distance from reference datum to CG of an item
AGL Above ground level
A/C Aircraft
ATC Air traffic control
AWS Aural Warning System
BATT Battery
BIT Built in test
°C Degrees centigrade
CAP Caution Advisory Panel
CB Circuit breaker
CCW Counterclockwise
CDI Course deviation indicator
comm/nav Communication/navigation
CW Clockwise
CG Center of gravity. Point at which the helicopter would balance if suspended. Its distance from reference datum is found by dividing total moment by total weight

Kaman K-1200
Rotorcraft Flight Manual

| | |
|--------------|--------------------------------------------------------------------------------------------------------------------------|
| CG arm | Arm from reference datum obtained by adding the helicopter's individual moments and dividing the sum by the total weight |
| CG limits | Extreme CG locations within which the helicopter must be operated at a given weight |
| DA | Density altitude. Pressure altitude corrected for OAT |
| DC | Direct current |
| EGT | Exhaust gas temperature |
| EMERG | Emergency |
| empty weight | Weight of a standard empty helicopter, including unusable fuel, full operating fluids, and full oil |
| ENG | Engine |
| EXT | External |
| °F | Degrees Fahrenheit |
| FLT | Flight |
| FOD | Foreign object damage |
| FWD | Forward |
| FT | Feet |
| GAL | Gallons |
| GEN | Generator |
| GND | Ground |
| GOV | Governor |
| GW | Gross weight |
| HEC | Human external cargo (Class A only) |
| HIT | Health indicator test |
| HP | Horsepower |
| HSI | Horizontal situation indicator |
| IFR | Instrument flight rules |
| IMC | Instrument meteorological conditions |
| ICS | Intercom system |
| IGE | In ground effect |
| in | Inches |
| INT | Internal |
| KCAS | Knots calibrated airspeed. The airspeed shown on the airspeed indicator, corrected for instrument and position error |
| KIAS | Knots indicated airspeed. The airspeed shown on the airspeed indicator, corrected for instrument error |

Kaman K-1200
Rotorcraft Flight Manual

| | |
|----------------------------------|--------------------------------------------------------------------------------------------------------------------------------------------------------------------------|
| KMM | K-MAX Maintenance Manual |
| KTAS | Knots true airspeed. The airspeed relative to undisturbed air. KCAS corrected for pressure altitude and temperature |
| KTS | Knots |
| Kw-H | Kilowatt-hours |
| l | Liters |
| LBS | Pounds |
| LH | Left hand |
| m | Meters |
| MCP | Maximum continuous power |
| MGTO | Maximum gross takeoff |
| MGW | Maximum gross weight |
| moment | The product of the weight of an item multiplied by its arm |
| MSL altitude | Altitude in feet shown by the altimeter (corrected for instrument and position errors) when the barometric pressure is set to that existing at sea level |
| NHEC | Non-Human external cargo |
| NM | Nautical miles |
| N _R | Rotor RPM |
| N _G (N ₁) | Engine gas generator RPM |
| N ₂ (N _P) | Engine power turbine RPM |
| OAT | Outside air temperature |
| OGE | Out of ground effect |
| PA | Pressure altitude. Altitude in feet shown by the altimeter (corrected for instrument and position errors) when the barometric pressure is set to 29.92 inches of mercury |
| PART SEP | Particle separator |
| payload | Weight of occupant, cargo, and baggage |
| PCDS | Personnel carrying device system (Class A only) |
| press | Pressure |
| PSI | Pounds per square inch |
| PWR | Power |
| Q | Engine torque pressure |
| reference datum | Imaginary vertical plane from which all horizontal distances are measured for balance purposes |
| RH | Right hand |

Kaman K-1200
Rotorcraft Flight Manual

| | |
|-------------------|-----------------------------------------------------------------------------------------------------------|
| RPM | Revolutions per minute |
| SAS | Stability augmentation system |
| SB | Service Bulletin |
| SL | Sea level |
| SHP | Shaft horsepower (23.3 SHP = 1 PSI Q) |
| station | A location along the helicopter fuselage. Usually given in terms of inches from the reference datum |
| tach | tachometer |
| unusable fuel | Fuel remaining in the sump in level fuse- lage attitude which cannot be pumped to the engine |
| usable fuel | Fuel available for flight planning |
| useful load | Difference between maximum takeoff weight and empty weight |
| VDC | Volts direct current |
| VFR | Visual flight rules |
| VMC | Visual meteorological conditions |
| V_{mini} | Instrument flight minimum airspeed |
| V_{ne} | Never exceed airspeed |
| V_{nei} | Instrument flight never exceed airspeed |
| VOR | Very high frequency omni range |
| V_y | Best rate of climb airspeed |
| wt | Weight |
| XMSN | Transmission |
| < | Less than |
| > | Greater than |

Conversion Tables

The following tables (Tables 1-1 through 1-3) provide a ready reference for commonly used conversions:

Table 1-1. Metric to English Conversion

| <u>Multiply</u> | <u>By</u> | <u>To Obtain</u> |
|------------------|-----------|---------------------|
| centimeters (cm) | 0.3937 | inches (in) |
| meters (m) | 3.2808 | feet (ft) |
| kilometers (km) | 0.5400 | nautical miles (nm) |
| kilometers (km) | 0.6214 | statute miles (mi) |
| liters (l) | 1.0567 | quarts (qt) |
| liters (l) | 0.2642 | U.S. gallons (gal) |
| kilograms (kg) | 2.2046 | pounds (lb) |

Table 1-2. English to Metric Conversion

| <u>Multiply</u> | <u>By</u> | <u>To Obtain</u> |
|---------------------|-----------|------------------|
| quarts (qt) | 0.9464 | liters (l) |
| U.S. gallons (gal) | 3.785 | liters (l) |
| inches (in) | 25.40 | millimeters (mm) |
| inches (in) | 2.540 | centimeters (cm) |
| feet (ft) | 0.3048 | meters (m) |
| nautical miles (nm) | 1.8520 | kilometers (km) |
| statute miles (mi) | 1.6093 | kilometers (km) |
| pounds (lb) | 0.4536 | kilograms (kg) |

Table 1-3. Temperature Conversion

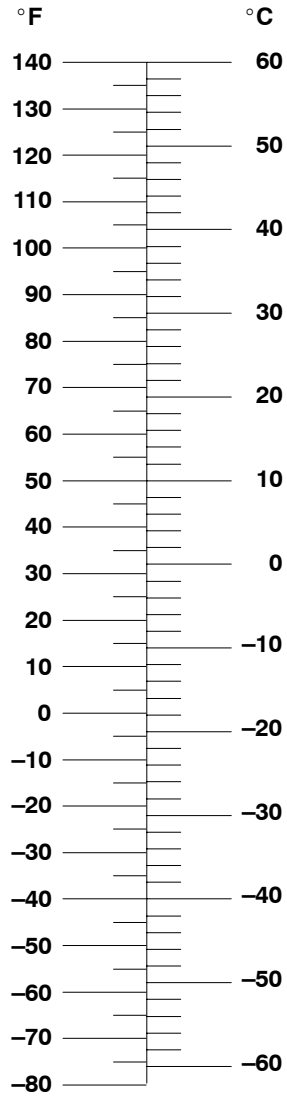

Section 2 Limitations

Contents

| | |
|------------------------------------------------------------|------|
| General | 2-2 |
| Operating limitations | 2-2 |
| Flight limitations NO LOAD | 2-3 |
| Flight limitations WITH LOAD | 2-4 |
| Flight limitations IMC | 2-4 |
| Powerplant/drive system limitations | 2-4 |
| Rotor limitations | 2-6 |
| Weight limitations | 2-7 |
| System limitations | 2-7 |
| External PCDS Limitations | 2-7 |
| Instrument markings | 2-8 |
| Instrument color codes | 2-8 |
| Torque indicator (no load/outer band) | 2-8 |
| Torque indicator (with load/inner band) | 2-8 |
| Airspeed indicator (no load/outer band) | 2-8 |
| Airspeed indicator (with load/inner band) | 2-8 |
| Engine/rotor dual tachometer (rotor/outer band) | 2-8 |
| Engine/rotor dual tachometer (engine/inner band) | 2-8 |
| Rotor RPM warning system | 2-9 |
| Load indicator | 2-9 |
| Engine oil pressure indicator | 2-9 |
| Engine oil temperature indicator | 2-9 |
| N _G indicator | 2-9 |
| EGT indicator | 2-9 |
| Transmission oil pressure indicator | 2-9 |
| Transmission oil temperature indicator | 2-9 |
| Fuel pressure indicator | 2-9 |
| Voltmeter | 2-9 |
| Ammeter | 2-9 |
| Placards | 2-13 |

General

This section includes operating limitations, instrument markings, and basic placards required for safe operation of the helicopter, its engine, and other standard systems. This helicopter is approved under FAA Type Certificate No. TR7BO as model K-1200.

This rotorcraft is certified in the normal category and is eligible for the following kinds of operation when the appropriate instruments and equipment required by the airworthiness and/or operating rules are installed, approved, and are in operable condition:

1. VFR day/night
2. IFR day/night
3. External load operations

The K-1200 is also certified for an increased takeoff gross weight of 6500 pounds for the following special purposes:

1. Agricultural operations in accordance with FAR 137
2. Dispensing of firefighting materials
3. External load operations in accordance with FAR 133

Operating Limitations

| | |
|-----------------------------------------------------------------------------------------------------------|-----------------------------------------------------------------------------------------------------------------------------------------------------------------------------------------------------------------------------------------------------------------------------------------------------------------------------------------------------------|
| To file IFR | Requires the following equipment to be installed and operable: |
| | <ul style="list-style-type: none">• Primary Attitude Gyro• Standby Attitude Gyro• Two Radios appropriate for flight• Navigation System appropriate for flight• Boost and SAS• HSI, Wet Compass, and Transponder• Standby Battery and factory approved IFR electrical bus installation |
| Flight into known icing conditions | Prohibited |
| Acrobatic flight | Prohibited |
| Horizontal acceleration prior to any load clearing the supporting surface(s) (class B load only) | Prohibited |
| Maximum operating altitude | 15,000 ft. DA (VFR) 12,000 ft. DA (IFR) |
| Operating temperature range | -32°C to +49°C |

| | |
|-------------------------------------------------------|-------------------------------------------------------------------------------------------------------------------------------|
| Doors (any combination of cockpit or cargo) | Flight with doors removed approved to 100 KIAS maximum |
| Windows | Flight with any or all windows open approved to 100 KIAS maximum (No change in airspeed limitation with flip windows removed) |

NOTE

Takeoff gross weight limited to 6,000 pounds for operations other than those covered under the general paragraph for limitations.

| | |
|------------------------------------------------------------------------|--------------|
| Maximum takeoff/landing weight | 6,500 pounds |
| FM radio use for ATC functions | Prohibited |
| Use of engine exhaust to melt snow and ice from rotor blades | Prohibited |

PCDS USE RESTRICTED TO FOLLOWING:

- Single occupant per seat
- VFR operations only
- Essential crew
- 300 lbs. maximum weight per seat

Flight Limitations—NO LOAD

| | |
|-----------------------------------------------------|--------------------------------------------------------------------|
| Maximum autorotation airspeed | 80 KIAS (steady state) |
| V _{ne} (power ON) | 100 KIAS (0–5000 ft. DA). Decrease 3 knots/1000 ft. above 5000 ft. |
| V _{ne} (power OFF) | 80 KIAS (0–5000 ft. DA). Decrease 3 knots/1000 ft. above 5000 ft. |
| Maximum groundspeed (nose wheel locked) | 25 knots |
| Maximum groundspeed (nose wheel unlocked) | 10 knots |
| Maximum angle of bank | 45° VFR |
| Maximum pitch attitude | ±25° |
| Maximum hover turn rate | 45° per second |
| V _{ne} (SAS on) | 90 KIAS |
| V _{nei} | 90 KIAS |
| V _{mini} | 40 KIAS |

Flight Limitations—WITH LOAD

NOTE

Refer to External PCDS Limitations section for restrictions associated with Class A (HEC) loads.

| | |
|-------------------------------|----------------------------------------------------------------------|
| V _{ne} | 80 KIAS (0–5000 ft. DA). Decrease 3 knots/1000 ft. above 5000 ft. DA |
| Maximum angle of bank | 30° |
| Maximum pitch attitude | ±25° |
| Maximum hover turn rate | 45° per second |

Flight Limitations—IMC

| | |
|---------------------------------------|-------------------------------------------------------------------|
| V _{mini} | 40 KIAS |
| V _{nei} | 90 KIAS (0–8000 ft. DA). Decrease 3 knots/1000 ft. above 8000 ft. |
| Maximum angle of bank | 30° |
| Maximum rate of climb or decent | 1000 ft. per min. |
| Maximum altitude | 12,000 ft. DA |

NOTE

External load operations have not been demonstrated for IFR operations.

NOTE

IMC flight is prohibited without the approved aircraft IFR package.

Powerplant/Drive System Limitations

| | |
|----------------------------------------------|--------------------------------------------|
| N _G % RPM (takeoff) | 105% |
| N _G % RPM (mcp) | 101% |
| N ₂ % RPM | 105% |
| EGT | See Figure 2-1 |
| Torque – with load (104% N _R): | |
| maximum | 58 PSI |
| caution range | 45–58 PSI (0–25 KIAS/5 minutes maximum) |
| normal range | 0–45 PSI |
| Torque – no load (100–104% N _R): | |
| maximum | 40 PSI |
| normal range | 0–40 PSI |
| Engine oil temperature | 93°C |

Engine oil pressure:
maximum 100 PSI
normal range 80–100 PSI
minimum for flight 60 PSI
minimum @ FLT IDLE 25 PSI
minimum @ GND IDLE 10 PSI
Approved engine oils MIL-L-7808 or MIL-L-23699 (See
Section 10 for additional information)

Transmission oil temperature:
maximum 120°C
normal range 29.5–120°C
minimum 29.5°C

Transmission oil pressure:
maximum 79 PSI
normal range 28–79 PSI
minimum 28 PSI
Approved transmission oils DEXRON II, DEXRON III
Approved hydraulic oils MIL-H-83282

Fuel pressure:
maximum 25 PSI
normal range 7–15 PSI
minimum 5 PSI
Total usable fuel 1,492 lbs. JP-5/Jet A (219.5 gal, 831 l)
Approved fuels MIL-T-5624, Grade JP-4/Jet B and
JP-5/Jet A, or equivalent (See Section 10
for additional information)

Starter/generator:
normal voltage 27–29 VDC
maximum amperage 225 amps

Engine start cycle 30 seconds ON / 30 seconds OFF
30 seconds ON / 30 seconds OFF
30 seconds ON / 30 minutes OFF

Rotor Limitations

Power on:

| | |
|--------------------|----------------------------------------------------------------------------------------------------------|
| maximum | 105% N _R |
| normal range | 100-104% N _R (VFR) 104% N _R (IFR) |
| minimum | 100% N _R ≤ 6,500 lbs 104% N _R > 6,500 lbs 104% N _R > 10,000 Ft DA |

Power off:

| | |
|----------------------------------------------|------------------------|
| maximum | 100% N _R |
| normal range | 75-100% N _R |
| minimum | 75% N _R |
| Maximum for extended ground operations | 100% N _R |

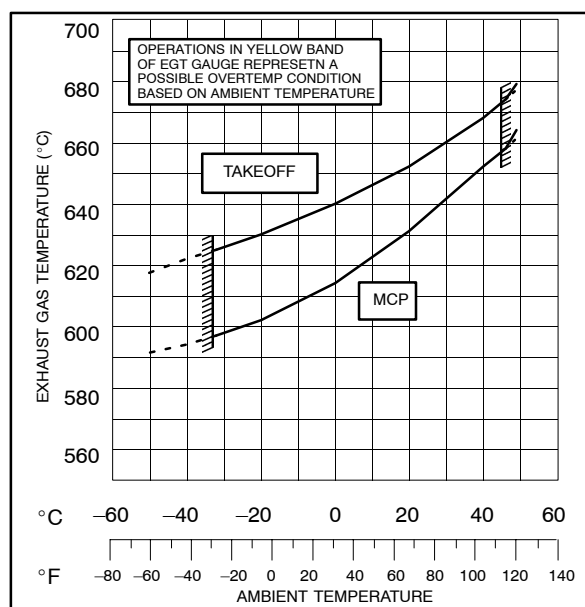

Figure 2-1. EGT Limitations

Weight Limitations

NOTE

Takeoff gross weight limited to 6,000 pounds for operations other than those covered under the general paragraph for limitations.

| | |
|------------------------|------------------------------------------------------------|
| Aircraft | 6,500 lbs. (2,948 kg) |
| With HEC | 6,500 lbs. (2,948 kg) |
| With jettisonable load | 12,000 lbs. (5,443 kg) |
| Maximum hook load | 6,000 lbs. (2,721 kg) |
| Datum line | 6.265 in (15.913 cm) forward of nose |
| Forward CG limit | 167.0 in (424.18 cm) aft of datum line (See Figure 2-2) |
| Aft CG limit | 172.0 in (436.88 cm) aft of datum line (See Figure 2-2) |

System Limitations

| | |
|----------------------------------|--------------------------------------------------------------------------------------------------------------------------------------------------------|
| Rotor brake | Do not apply rotor brake with engine running. Maximum rotor RPM for rotor brake application is 40% N _R . |
| Bleed air | Cabin heat and engine anti-ice should not be activated when ambient temperatures exceed the following: No load 33°C (92°F) With load 25°C (77°F) |
| SAS pitch and roll stabilization | Boost system must be operating for pitch and roll stability. |

External PCDS Limitations

| | |
|--------------------------------------------|--------------------------------------------------------------------------------------------------------------------------|
| Cargo | Class A (HEC) cargo not to be carried in the PCDS in combination with non-human external cargo (NHEC) on the cargo hook. |
| Maximum occupant weight: | 300 pounds |
| PCDS location | On either or both sides of aircraft. Aircraft may be operated with PCDS either folded or open. |
| Never exceed speed (empty PCDS): | 100 KIAS |
| Never exceed speed (human external cargo): | 70 KIAS |
| Safety helmet with eye protection | To be worn by PCDS occupants on all flights |
| PCDS restraints | Both 5-point harness and restraint lap belt must be utilized by occupants. |
| Cargo or equipment carried in seat | Prohibited |
| Embark or disembark | Directly in front of aircraft when rotors are turning. |

Instrument Markings

Instrument color codes:

| | |
|------------------|---------------------------------------------------------------------------------------------|
| green | Normal range. Operation in this range is unlimited. |
| yellow | Cautionary range. Operation in this range should be for a limited time only. |
| red | Operating limit. The instrument pointer should not enter a red arc or linger on a red line. |

Torque indicator (no load/outer band): (Figure 2-3)

| | |
|---------------------|----------|
| green arc | 0-40 PSI |
| red line | 40 PSI |

Torque indicator (with load/inner band): (Figure 2-3)

| | |
|----------------------|-----------|
| green arc | 0-45 PSI |
| yellow arc | 45-58 PSI |
| red line | 58 PSI |

Airspeed indicator (no load/outer band):

| | |
|-------------------------------------------------|------------|
| green arc | 0-100 KIAS |
| red cross-hatched line (autorotation) | 80 KIAS |
| red line | 100 KIAS |

Airspeed indicator (with load/inner band):

| | |
|----------------------|------------|
| yellow arc | 0-25 KIAS |
| green arc | 25-80 KIAS |
| red line | 80 KIAS |

Engine/rotor dual tachometer (rotor/outer band):

| | |
|--------------------------|---------|
| red line | 75% |
| thin green arc | 75-104% |
| red line | 105% |

Engine/rotor dual tachometer (engine/inner band):

| | |
|---------------------------|----------|
| thick green arc | 100-104% |
| red line | 105% |

Rotor RPM warning system:

intermittent audio tone 75–88±1%
steady audio tone > 107±1%
flashing rotor lamp 75–88±1% or > 107±1%

Load indicator: (Figure 2–4)

red line 6000 lbs

Engine oil pressure indicator:

lower red line 25 PSI
green arc 80–100 PSI
upper red line 100 PSI

Engine oil temperature indicator:

red line 93°C

N_G indicator: (Figure 2–5)

red line 105%

EGT indicator: (Figure 2–6)

yellow arc 630–674°C
red line 674°C

Transmission oil pressure indicator:

red line 28 PSI
green arc 28–79 PSI
red line 79 PSI

Transmission oil temperature indicator:

red line 29.5°C
green arc 29.5–120°C
red line 120°C

Fuel pressure indicator:

red line 5 PSI
green arc 7–15 PSI
red line 25 PSI

Voltmeter:

green arc 27–29 volts

Ammeter:

red line 225 amps

CG LIMITS

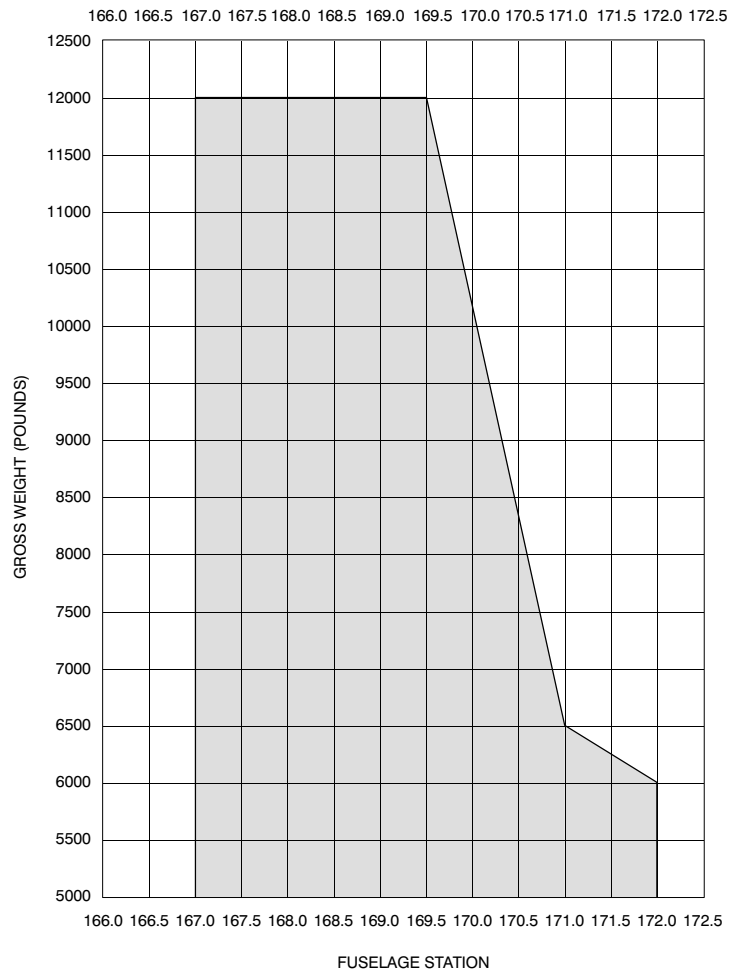

Figure 2-2. CG Limits

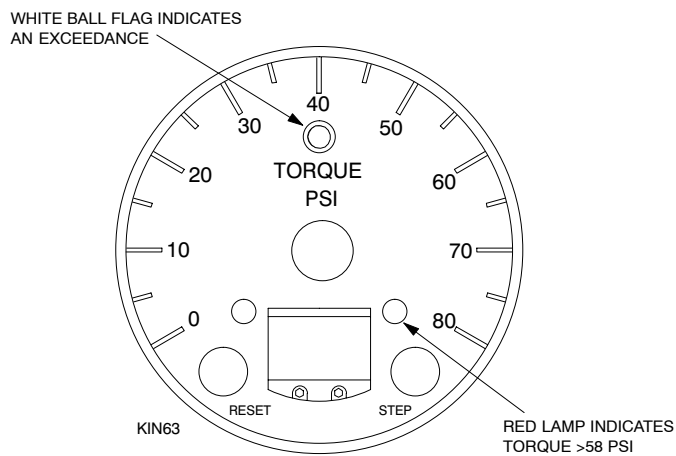

Figure 2-3. Torque Indicator

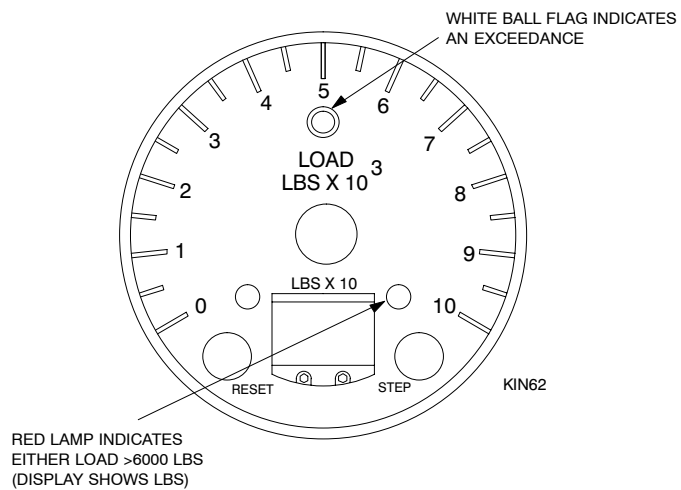

Figure 2-4. Load Indicator

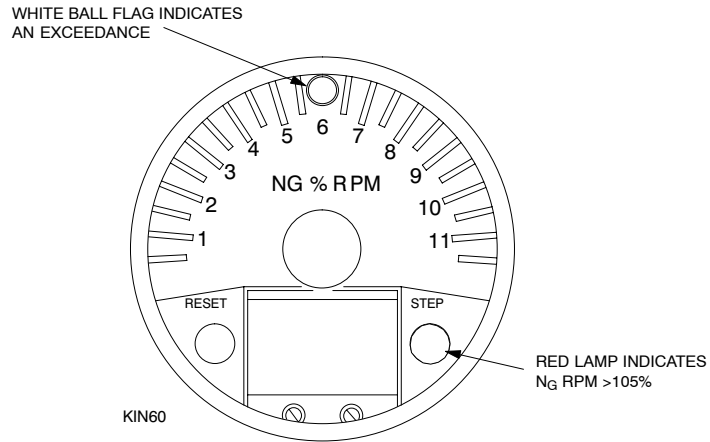

Figure 2-5. NG Indicator

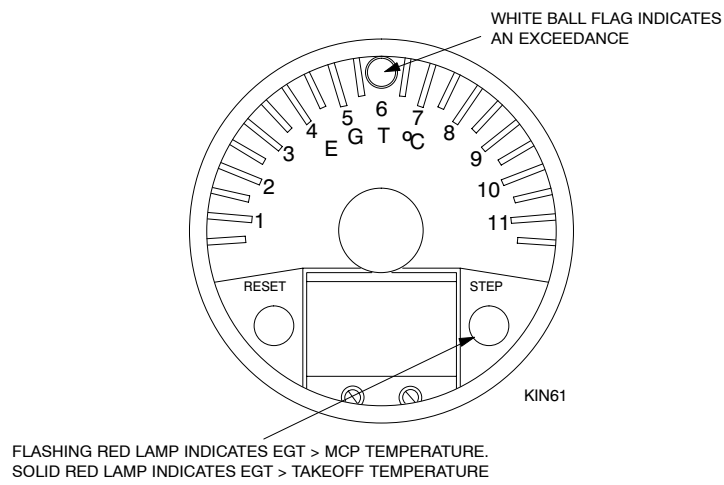

Figure 2-6. EGT Indicator

Placards

Located on Cockpit Overhead Console:

| |
|------------------------------------------------------------------------------------------------------------------------------------------------------------------------------------------------------------------------------------------------------------------------------------------------------------------------------------------------------------------------------------------------------------------------------------------------------------------------------------------------------------------------------------------------------------------------------------------------------------------------------------------------------------------------------------------------|
| <p>AIRCRAFT LIMITATIONS DAY AND NIGHT VFR ONLY</p> <p>Vne POWER ON: 100 KIAS Vne POWER OFF: 80 KIAS</p> <p>DECREASE Vne 3 KIAS PER 1000 FT ALTITUDE ABOVE 5000 FT DA MAXIMUM TORQUE: 40 PSI WITHOUT EXTERNAL LOADS ROTOR RPM: POWER ON - 100 - 104 % POWER OFF - 75 - 100 % MAXIMUM ALTITUDE: 15000 FT DA MAXIMUM GROSS WEIGHT (A/C & EXT LOAD): 12000 LBS</p> <p>EXTERNAL LOAD OPERATING LIMITS</p> <p>Vne: 80 KIAS</p> <p>MAXIMUM TORQUE: 58 PSI ≤ 25 KIAS (5 MIN) 45 PSI > 25 KIAS (CONTINUOUS) ROTOR RPM: GROSS WGT ≤ 6500# : 100 - 104 % GROSS WGT > 6500# : 104 % MAXIMUM HOOK WEIGHT: 6000 LBS (INCLUDING TARE)</p> |
|------------------------------------------------------------------------------------------------------------------------------------------------------------------------------------------------------------------------------------------------------------------------------------------------------------------------------------------------------------------------------------------------------------------------------------------------------------------------------------------------------------------------------------------------------------------------------------------------------------------------------------------------------------------------------------------------|

| |
|--------------------------------------------------------------------------------------------------------------------------|
| <p>EXTERNAL LOAD CLASSIFICATION</p> <p>THIS AIRCRAFT IS APPROVED FOR CLASS B, C EXTERNAL LOADS</p> |
|--------------------------------------------------------------------------------------------------------------------------|

| |
|--------------------------------------------------------------------------------------------------------------------------------------------------------------------------------------------------------------------------------------------------------------|
| <p>EXTERNAL LOAD CHECKLIST</p> <p>LOAD METER- TEST HOOK ARM/SAFE SWITCH- ARMED</p> <p>ROTOR RPM- SET FOR EXT. LOAD CYCLIC: HOOK RELEASES- CHECK</p> <p>MANUAL HOOK RELEASE- CHECK COLLECTIVE: HOOK RELEASES- CHECK</p> |
|--------------------------------------------------------------------------------------------------------------------------------------------------------------------------------------------------------------------------------------------------------------|

| |
|---------------------------------------------------------------------------------------------------------------------------------------------------|
| <p>THIS AIRCRAFT MUST BE OPERATED IN COMPLIANCE WITH THE OPERATING LIMITATIONS SPECIFIED IN THE FAA APPROVED FLIGHT MANUAL</p> |
|---------------------------------------------------------------------------------------------------------------------------------------------------|

| |
|--------------------------|
| <p>NO SMOKING</p> |
|--------------------------|

Located on Cockpit Overhead Console for PCDS Configuration:

**AIRCRAFT LIMITATIONS
DAY AND NIGHT VFR**
Vne POWER ON: 100 KIAS
Vne POWER OFF: 80 KIAS
DECREASE Vne 3 KIAS PER 1000 FT ALTITUDE ABOVE 5000 FT DA
MAXIMUM TORQUE: 40 PSI WITHOUT EXTERNAL LOADS
ROTOR RPM: POWER ON - 100 - 104 %
POWER OFF - 75 - 100 %
MAXIMUM ALTITUDE: 15000 FT DA
MAXIMUM GROSS WEIGHT (A/C & EXT LOAD): 12000 LBS
EXTERNAL LOAD OPERATING LIMITS
Vne: 80 KIAS
70 KIAS CLASS A HEC
MAXIMUM TORQUE: 58 PSI ≤ 25 KIAS (5 MIN)
45 PSI > 25 KIAS (CONTINUOUS)
ROTOR RPM: GROSS WGT ≤ 6500# : 100 - 104 %
GROSS WGT > 6500# : 104 %
MAXIMUM HOOK WEIGHT: 6000 LBS (INCLUDING TARE)

**EXTERNAL LOAD
CLASSIFICATION**
**THIS AIRCRAFT IS APPROVED FOR
CLASS A, B, C EXTERNAL LOADS**

EXTERNAL LOAD CHECK LIST - CLASS B, C

| | |
|-------------------------------------------------------|-----------------------------------------------------------|
| <input type="checkbox"/> LOAD METER- TEST | <input type="checkbox"/> HOOK ARM/SAFE SWITCH- ARMED |
| <input type="checkbox"/> ROTOR RPM- SET FOR EXT. LOAD | <input type="checkbox"/> CYCLIC: HOOK RELEASES- CHECK |
| <input type="checkbox"/> MANUAL HOOK RELEASE- CHECK | <input type="checkbox"/> COLLECTIVE: HOOK RELEASES- CHECK |

CLASS A - PCDS / CREW SECURE

**THIS AIRCRAFT MUST BE OPERATED
IN COMPLIANCE WITH THE OPERATING
LIMITATIONS SPECIFIED IN THE FAA
APPROVED FLIGHT MANUAL**

NO SMOKING

Located on Cockpit Overhead Console for IFR Installation:

| AIRCRAFT LIMITATIONS | |
|--------------------------------------------------------------------|-------------------------------|
| DAY AND NIGHT VFR | |
| Vne POWER ON: 100 KIAS | MAXIMUM ALTITUDE: 15000 FT DA |
| Vne POWER OFF: 80 KIAS | SAS ON: 90 KIAS |
| DECREASE Vne 3 KIAS PER 1000 FT ALTITUDE ABOVE 5000 FT DA | |
| MAXIMUM TORQUE: 40 PSI WITHOUT EXTERNAL LOADS | |
| ROTOR RPM: POWER ON: 100 - 104% POWER OFF: 75 - 100% | |
| MAXIMUM GROSS WEIGHT (A/C & EXT LOAD): 12000 LBS | |
| EXTERNAL LOAD OPERATIONS | |
| Vne: 80 KIAS | |
| 70 KIAS CLASS A HEC | |
| MAX TORQUE: 58 PSI ≤ 25 KIAS (5 MIN) 45 PSI > 25 KIAS (CONTINUOUS) | |
| ROTOR RPM: GROSS WGT ≤ 6500#: 100 - 104% GROSS WGT > 6500#: 104% | |
| MAXIMUM HOOK WEIGHT: 6000 LBS (INCLUDING TARE) | |
| DAY AND NIGHT IFR | |
| Vnei: 90 KIAS | MAX ALTITUDE: 12000 FT DA |
| Vmini: 40 KIAS | |
| DECREASE Vnei 3 KIAS PER 1000 FT ALTITUDE ABOVE 8000 FT DA | |
| MAX RATE OF CLIMB OR DESCENT: 1000 FT PER MIN | |
| NOTE | |
| REFER TO FLIGHT MANUAL FOR REQUIRED EQUIPMENT TO FILE IFR | |
| EXTERNAL LOAD OPERATIONS HAVE NOT BEEN DEMONSTRATED FOR IFR | |

| AIRSPEED INDICATOR CALIBRATION CARD | | | | | | | | | | |
|--------------------------------------------|----|----|----|----|----|----|----|----|----|-----|
| KIAS | 10 | 20 | 30 | 40 | 50 | 60 | 70 | 80 | 90 | 100 |
| KCAS PRIMARY STATIC | | | | | | | | | | |
| KCAS AUX AIR SOURCE | | | | | | | | | | |

KIFR60

Located on Cockpit Overhead Console:

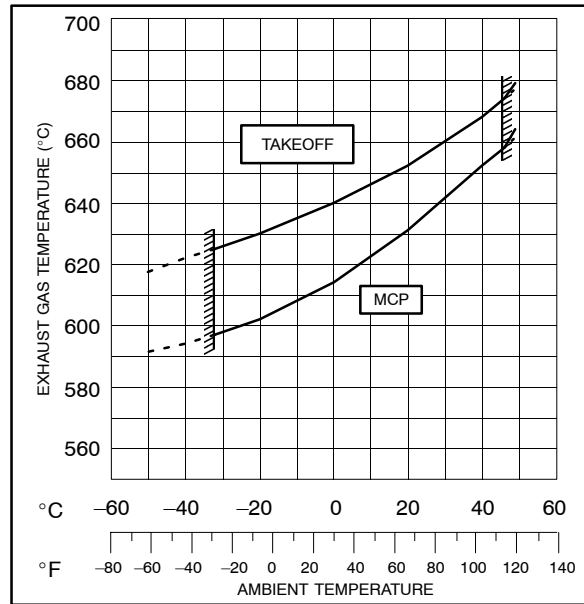

Located on Instrument Panel:

| ENG SER # | |
|-------------------|--------------|
| DATA PLATE TORQUE | |
| COCKPIT TORQUE | CHART TORQUE |
| 20 | |
| 25 | |
| 30 | |
| 35 | |
| 40 | |
| 45 | |
| 50 | |

Located on Cockpit Overhead Console:

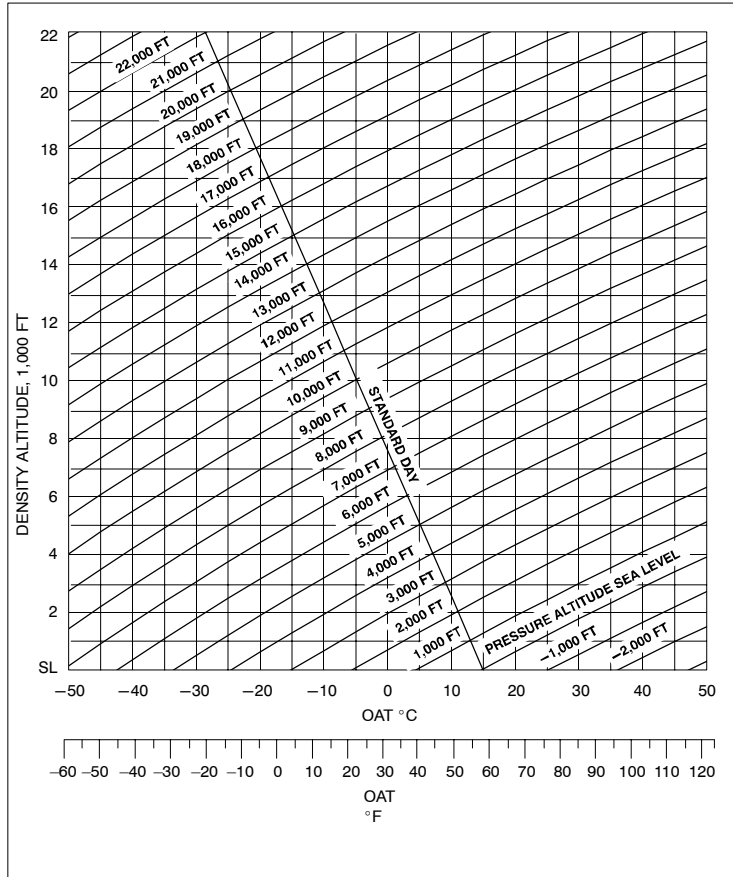

Located on Instrument Panel:

RADIO CALL XXXXXX

**TAKEOFF / LANDING
CHECK LIST**
○ ROTOR RPM: 100-104% ○
PART. SEPARATOR: ON
WHEEL BRAKES: AS REQD
NOSE WHEEL: LOCKED

Located Inside LH and RH Cargo Doors:

CARGO COMPARTMENT
**SEE FLIGHT MANUAL
FOR CG LIMITATIONS**
MAX WT: 500 LBS
**MAX FLOOR LOAD:
100 LBS/SQR FT**

Located Inside Engine Oil Access Door:

**ENGINE OIL
3.2 US GAL. (12.1 L)
MIL-L-23699 OR
MIL-L-7808**

Located Near Fuel Cell Filler Cap:

| |
|-----------------------------------------------------------------------------------------------------------------------------|
| FUEL |
| JP-4/JP-5 |
| SEE FLIGHT MANUAL FOR ADDITIONAL FUELS AND FUELING PROCEDURES. MIL-I-27686 ADDITIVE MAY BE REQUIRED. |

Located Inside Transmission Oil Access Door:

| |
|---------------------------------------------------------------|
| XMSN OIL 3.2 US GAL. (12.1 L) DEXRON II OR III |
|---------------------------------------------------------------|

Located Inside Hydraulic Fluid Access Door: (After SB 070)

| |
|------------------------------------------------------------------------------|
| HYDRAULIC FLUID 3.2 U.S. GAL (12.1 L) MIL-H-83282 |
|------------------------------------------------------------------------------|

Located Inside External Power Access Door:

28 VDC

Located Near Rotor Brake Master Cylinder:

ROTOR BRAKE
ON ← **→** **OFF**

Located on Pilot Seat Support Tube:

UNLOCK INERTIA REEL LOCK

Located on RH Fuselage Aft of Cabin Door

**KAMAN AEROSPACE
CORPORATION
BLOOMFIELD, CT**
**MODEL DESIGNATION
K-1200**
**MFGR'S SERIAL NUMBER
XXXXXX**
**PRODUCTION CERT NO.
117NE**

Stenciled on Floor Panel Under Pilot Seat:

**WARNING
DO NOT
STOW ARTICLES OR
EQUIPMENT UNDER SEAT**

Located on LH and RH Cockpit Doors (Near Door Handle, Both Internal and External):



Stenciled on Cargo Hook Assembly:

**84955 – K931280–009
CARGO HOOK ASSY**

CAPACITY: 6000 LBS

**KAMAN AEROSPACE
CORPORATION
BLOOMFIELD, CT**

Located on External Seat Pan for PCDS Installation:

WARNING

IF ROTORS ARE TURNING, EXIT TO THE FRONT OF THE AIRCRAFT
CHECKLIST MUST BE COMPLETED BEFORE EACH FLIGHT

1. VERIFY SEAT MOUNT IS TIGHTLY LATCHED AND SAFETY PINNED
2. SECURE LOCKING COLLARS ON SIDE BARS BY SLIDING DOWN
3. SECURE OR REMOVE LOOSE CLOTHING AND MATERIALS
4. CONNECT AND VERIFY THAT ICS IS OPERATING
5. SECURE AND CHECK 5-POINT HARNESS AND LAP BELT
6. SECURE EXCESS BELT LENGTHS
7. SECURE ICS WIRING FOR FORWARD FLIGHT
8. SECURE HEAD AND EYE PROTECTION

USE RESTRICTED TO:

- SINGLE OCCUPANT
- VFR OPERATIONS ONLY
- ESSENTIAL CREW
- 300 LBS MAXIMUM

Located on ICS Receptacle Mounting Bracket for PCDS Installation:

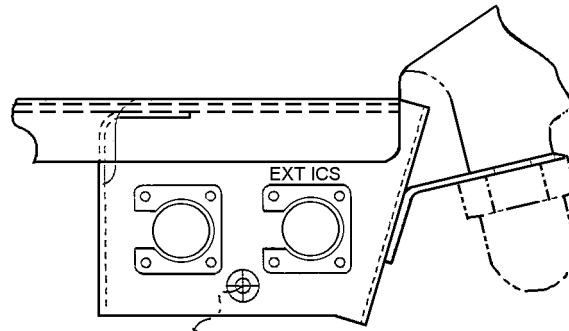

PCDS1

Section 3 Normal Procedures

Contents

| | |
|---------------------------------------------------|------|
| General | 3-2 |
| Preflight checklist | 3-2 |
| Pre-start checklist | 3-11 |
| Engine start/rotor engagement checklist | 3-12 |
| Ground taxi checklist | 3-14 |
| Pre-takeoff checklist | 3-14 |
| Takeoff/landing checklist | 3-14 |
| General | 3-14 |
| Takeoff procedure | 3-15 |
| External load checklist | 3-15 |
| Landing procedure | 3-16 |
| Shutdown checklist | 3-16 |
| IFR procedures | 3-17 |
| Miscellaneous procedures | 3-18 |
| Post-flight procedures | 3-18 |
| Caution panel test switch | 3-18 |
| Particle separator | 3-18 |
| Cabin heat/vent | 3-18 |
| Engine anti-ice | 3-18 |
| Pitot Heat | 3-18 |
| Doors/skids | 3-18 |
| Cold weather operations | 3-19 |
| Hot weather operations | 3-19 |
| IFR operations (IFR equipped aircraft) | 3-19 |
| Power assurance check | 3-19 |

General

The pilot will determine that the following preflight has been accomplished before the first flight of the day or before the next flight after maintenance. Asterisk (*) items should be accomplished before every flight. Detailed component inspection requirements are listed in the KMM.

Components should be inspected for security, wear, corrosion, structural integrity, and proper operation. Wiring should be inspected for chafing, routing, security, and deterioration. Fluids must be checked for proper levels and no leakage. All access panels, doors, and latches must be secured.

WARNING

Pilots should positively identify all aircraft switches, prior to actuation, when complying with checklist items or while making inflight switch setting changes.

Preflight Checklist

Nose Section

1. * Open nose compartment door
2. Door latches
3. Door rubber seals
4. Door hinges
5. Door strut
6. Nose wheel locking conduit
7. * Battery
8. * Battery connection for security
9. Battery vent lines
10. * Remove pitot cover
11. * Pitot tube
12. Heater motor
13. Heater ducting and diffuser
14. External power receptacle
15. Electrical components
16. * Static ports
17. * Landing light
18. LH and RH tiedown fittings
19. Mirrors and mounts (if installed)
20. Exterior/interior fuselage skin.

21. * Close nose compartment door
22. * Hood latches

Nose Wheel

1. * Nose wheel strut
2. * Nose wheel lock mechanism and shear pin
3. * Tire
4. * Wheel assembly
5. * Skid assembly (if installed)

LH Fuselage and Landing Gear

1. * LH door assembly
2. * LH door window
3. LH door seals
4. * OAT temperature probe
5. * Transmission oil reservoir for correct oil level.
 - a. If oil below LOW line, service to TOP line. (Ref. KMM chapter 12)
6. Transmission oil tank assembly
7. * LH position light
8. * Exterior fuselage skin
9. * LH brake line and guard
10. * PCDS (If installed)

Pre-Operational Inspection

- a. Verify PCDS mount is tightly latched and safety pinned.
 - b. Secure locking collars on side bars by sliding down.
 - c. Secure or remove loose clothing and materials.
 - d. Connect and verify ICS is operating.
 - e. Secure and check five-point harness and lap belt.
 - f. Secure excess belt length.
 - g. Secure ICS wiring for forward flight.
 - h. Secure head and eye protection.
11. * Cargo hook assembly
 12. * Main landing gear boom, LH side
 13. * Shock strut assembly
 14. * Tires
 15. * Wheel assembly

16. * Wheel brake caliper
17. * Skid assembly (if installed)
18. * Fuel filler cap secured
19. * Hydraulic fluid (oil) reservoir for correct oil level.
 - a. If oil below LOW line, service to TOP line. (Ref. KMM chapter 12)

Cargo Compartment

| |
|----------------|
| CAUTION |
|----------------|

No loose or unsecured material allowed in cargo area.

1. * Open LH cargo compartment door
2. * Cargo compartment door latches/hinges
3. Turn BATT switch ON (if necessary)
4. Turn transmission bay and cargo bay light switches ON (if necessary)
5. Open/remove access panels from overhead and tunnel
6. Upper tunnel cranks
7. Tunnel control rods (upper)
8. Control rods (Sta. 144 – Sta. 171)
9. Rudder cable and linkage
10. Longitudinal dampers
11. Longitudinal damper rods
12. Rotor brake accumulator
13. Collective limiter accumulator
14. Collective limiter filter
15. Transmission oil filter
16. Transmission housing
17. Transmission mounts
18. Throttle linkage
19. Oil pump/tach generator
20. Oil lines
21. LH azimuth
22. Bar-to-hub rods
23. Azimuth cam assembly
24. Lateral damper
25. Lateral damper rod
26. RH azimuth
27. Aft end of blower drive shaft

28. Oil shutoff valve
29. * Inspect for loose articles, oil/fuel leakage, and FOD in cargo area
30. Tunnel area
31. Fuselage skin and structure
32. Fuel shutoff valve
33. Fuel collector
34. Fuel filter
35. Install overhead and tunnel access panels
36. Turn transmission bay and cargo bay light switches OFF (if necessary)
37. Turn BATT switch OFF (if necessary)
38. * Close cargo compartment door

Tail Fuselage/Boom Area

1. Open LH engine cowling latch
2. LH work platform
3. * Tunnel access panel for security
4. * LH tail boom mount fittings
5. * LH exterior fuselage skin
6. * Anti-collision light
7. * LH stabilizer
8. * LH VOR antenna (if installed)
9. * Rudder assembly
10. * Tail position light
11. * Energy absorbing tube and skid
12. * RH VOR antenna (if installed)
13. * RH exterior tail boom skin
14. * RH tail boom mount fittings
15. * Lower tail boom mount fitting
16. * RH stabilizer
17. * RH work platform

RH Rotor

1. * Rotor hub assembly
2. * Fold lock assemblies
3. * Fold stops
4. Rotor shaft guard
5. * Droop stop assemblies
6. * Damper assemblies
7. Rotor shaft cover plate for security
8. * Hub L-cranks
9. * Hub-to-blade rods
10. * Teeter and lag pin covers for security
11. * U-crank assemblies
12. * Idler cranks
13. * Spanwise rod/turnbuckles and linkage
14. Spanwise rod rubber boots
15. * Blade grip
16. * Inboard blade area
17. * Blade track actuator
18. Slip ring assembly

Inter-Pylon Area

1. * Shear tie assembly
2. * Anti-collision light
3. * Walkways and cowlings
4. Forestry beacon (if installed)

LH Rotor

1. * Rotor hub assembly
2. * Fold lock assemblies
3. * Fold stops
4. Rotor shaft guard
5. * Droop stop assemblies
6. * Damper assemblies
7. Rotor shaft cover plate for security
8. * Hub L-cranks
9. * Hub-to-blade rods
10. * U-crank assemblies

11. * Idler cranks
12. * Spanwise rod/turnbuckles and linkage
13. Spanwise rod rubber boots
14. * Blade grip
15. * Inboard blade area
16. * Blade track actuator
17. Slip ring assembly

Engine Area

1. Open RH engine cowling latch
2. Slide open engine cowling
3. Cowling
4. * Engine external air inlet area

CAUTION

An aircraft parked for long periods in a sandy/dusty environment may accumulate FOD in inlet area. Inspect the inlet after prolonged parking in this environment.

5. Remove particle separator half
6. Rotate KAflex driveshaft in a counterclockwise direction (looking forward, freewheeling direction) and inspect for smooth operation.
7. Install particle separator half
8. Airframe fuel and oil lines
9. Engine mounts
10. Tail pipe internal/external
11. Engine areas
12. Fire/overheat detector sensor tubing
13. Throttle and actuator control linkage
14. Starter-generator and engine wiring harness
15. Engine control rods
16. Engine control linkage
17. * Particle separator latches

WARNING

The engine cowling protects engine components and provides fire containment. The engine cowling shall be installed during all flight operations.

18. Close engine cowling
19. * LH and RH cowling latches

LH Rotor Flaps/Outboard Blade Area

1. * Blade flap
2. * Flap brackets
3. Flap control rod and clevis
4. Flap rod
5. * Blade skin/trailing edge, tip caps, and leading edge abrasion strip
6. * Blade tiedown fittings

RH Rotor Flaps/Outboard Blade Area

1. * Blade flap
2. * Flap brackets
3. Flap control rod and clevis
4. Flap rod
5. * Blade skin/trailing edge, tip caps, and leading edge abrasion strip
6. * Blade tiedown fittings

RH Fuselage and Landing Gear

1. * Exterior fuselage skin
2. * Main landing gear boom, RH side
3. * Shock strut assembly
4. * Tires
5. * Wheel assembly
6. * Wheel brake caliper
7. * Skid assembly (if installed)
8. * RH position light
9. * Access, inspection, and compartment doors for secure closure
10. * RH brake lines and guard

11. * PCDS (If installed)

Pre-Operational Inspection

- a. Verify PCDS mount is tightly latched and safety pinned.
 - b. Secure locking collars on side bars by sliding down.
 - c. Secure or remove loose clothing and materials.
 - d. Connect and verify ICS is operating.
 - e. Secure and check five-point harness and lap belt.
 - f. Secure excess belt length.
 - g. Secure ICS wiring for forward flight.
 - h. Secure head and eye protection.
12. * Cargo compartment door latches/hinges
 13. * Engine oil reservoir for correct oil level. If oil is below LOW line, service to upper line on sight gage.
 14. Engine oil tank assembly
 15. Blower assembly and V-band
 16. Forward end of blower drive shaft
 17. Oil coolers
 18. Oil lines/fittings

Aircraft Underside

1. * Fuselage skin
2. * Oil and fuel leakage
3. * Antenna(s)

Cockpit

1. * RH door assembly
2. * RH door window
3. * Door hinges
4. * Cockpit floor
5. * Seat assembly
6. * Seat belts and shoulder harness
7. * Inertia reel
8. * Rudder pedals
9. * Cyclic stick
10. * Nose wheel locking handle
11. * Parking brake handle
12. * Collective stick assembly

13. * Circuit breaker panel
14. * Instruments
15. * Throttle checks at OFF, GND IDLE, FLT IDLE, and FLY positions
16. Rotor brake master cylinder
17. Fire extinguisher
18. Map lights
19. First aid kit
20. Overhead radio rack
21. Magnetic compass correction and V_{ne} cards
22. * Windshield and side windows
23. * Helicopter check list/Rotorcraft Flight Manual/required documents
24. Turn BATT switch ON
25. Check voltage and interior/exterior lights
26. Perform AWS BIT (if equipped), then return BIT switch to BIT DISABLE
27. Check AWS clutch SLIP EVENTS counter (if equipped)
28. Turn BATT switch OFF

CAUTION

It is recommended that fuel samples be taken from fuel sump before first flight of day and after refueling. If water and/or contaminants are present in fuel sample, consult the applicable airframe or engine publications for corrective action prior to flight.

***Fuel Sample**

1. Take fuel sample from fuel tank drain valve. Drain into suitable container. Check for water and contaminants in fuel sample.
2. With BATT and fuel oil switch ON, take fuel sample from airframe fuel filter. Check for water and contaminants in fuel sample.
3. Turn fuel pump and BATT switches OFF.
4. Drain fuel collector into suitable container.

Pre-Start Checklist

seat and restraint harness Adjusted
personnel carrying device system if installed and occupied
 pre-operational inspection Completed
 personnel restraint harness Adjusted
pedals Adjusted
nose wheel Locked
parking brake Set/reset
right circuit breakers In
RH switch panel switches
 anti-ice, pitot heat, and heat/vent switches Off
 avionics master Off
 CDI select (if installed) As desired
 EXT power Off
 SAS switches (if installed) Off
 INT/EXT light switches As desired
alternate static source selector (if installed) In
LH switch panel switches Off
left circuit breakers In
collective switches As desired
throttle Check for full travel and detents, then
 move to GND IDLE
collective friction As desired
flight controls Checked
rotor brake As desired

NOTE

Rotor brake is only recommended for start in winds above 15 knots.

BATT ON
standby power supply switch Momentary TEST, observe green lamp
(if installed) move switch to ARMED position

CAUTION

White ball flag requires maintenance action prior to further flight.

instrument BIT/ball flags Checked
external power As desired
fuel/oil switch ON; check fuel pressure 7-15 PSI (Check
fuel valve and oil valve lights illuminate
until valves are fully open)

caution/warning lights Test
master caution Reset
SAS disable switch (if installed) Light extinguished
radio(s) As desired

Engine Start/Rotor Engagement Checklist

area Clear
anti-collision light As required

NOTE

Forestry beacon should only be used when the aircraft is actively engaged in fire fighting operations.

forestry beacon (if installed) As required

WARNING

Ground personnel should approach aircraft from front whenever rotors are in motion. Restraint harness must be worn during all flight operations. Avoid sudden/abrupt control movements.

CAUTION

Maximum EGT during start is 675°C for up to five seconds.

CAUTION

Observe following starter limitations: 30 seconds ON / 30 seconds OFF / 30 seconds ON / 30 seconds OFF / 30 seconds ON / 30 minutes OFF

start trigger Pull and hold to 36% N_G, Monitor EGT, N_G, fuel pressure, and oil pressure [GND IDLE (48-52% N_G)]

CAUTION

Minimize engine run time with rotor brake on. Release rotor brake slowly to provide a smooth rotor engagement without any sudden rotor acceleration. Failure to slowly release rotor brake may result in lag stop pounding and main rotor blade damage.

rotor brake Release
transmission oil press Increasing

CAUTION

Ensure positive transmission oil pressure before moving throttle to FLT IDLE.

throttle FLT IDLE (68–72% N_G)
droop stops Out (approx. 50% N_R)
GEN ON
GEN/BATTERY test (IFR flight)
 overvolt test switch Test
 battery voltage >22VDC
 generator RESET then ON
boost (if installed) ON/Check
PART SEP ON
EXT PWR OFF; power source disconnected
AVIONICS MASTER ON
flight controls Check (rotors apex position verified)
fuel quantity/pressure Checked
communication/navigation radios On/Set

CAUTION

Some aircraft may not be configured with the yaw actuator. IFR flight is not authorized with yaw actuator removed.

SAS (if installed) On
interior/exterior lights (instrument flood lights on for night IFR) As desired
HSI Slaved/Aligned
standby compass Checked
transponder Set/On
doors (if installed) Closed
throttle FLY

NOTE

Throttle movement should be controlled and smooth from FLT IDLE to FLY.

Ground Taxi Checklist

NOTE

Ground taxi requires “up” collective (approx. 1/3) for normal pedal response. Wheel brakes may be used for precision maneuvering.

Do not ground taxi in winds above 15 knots. Do not use large cyclic inputs for ground taxi. Cyclic may be positioned slightly into wind line. Ground taxi should be limited to smooth, prepared surfaces clear of debris.

| | |
|---------------|-----------------------|
| rotor RPM | 85–90% N _R |
| nose wheel | Unlocked |
| landing light | As required |
| parking brake | Released |
| wheel brakes | Checked |

Pre-Takeoff Checklist

| | |
|---------------------------------|---------|
| engine/transmission instruments | Checked |
| caution/warning lights | Checked |

NOTE

The vertical gyro may take up to 2.5 minutes to erect. Roll SAS will not engage until the gyro is stabilized.

| | |
|-----------------------|-----------|
| attitude indicator(s) | Caged/Set |
| rotor track | Checked |

Takeoff/Landing Checklist

| | |
|--------------------|----------------------------------------------|
| rotor RPM | 100% minimum 104% (External loads or IFR) |
| particle separator | On |
| wheel brakes | As desired |
| nose wheel | Locked |

General

Takeoffs and landings were demonstrated on level, improved, and unimproved surfaces during certification flight testing. Forward speed upon touchdown was demonstrated on smooth, prepared surfaces.

Satisfactory climbout and approach speed combinations and altitudes are depicted in the Height/Velocity diagram (Figure 5–10) in Section 5.

Best rate-of-climb airspeed is 50 KIAS.

Takeoff Procedure

The normal aircraft takeoff includes vertical takeoff to a 5–10 foot hover, note hover torque, add five PSI, and transition to forward flight. The takeoff corridor is depicted in the Height/Velocity diagram (Figure 5–10) in Section 5.

WARNING

Rotor hub teeter angles directly relate to the clearance between a rotor blade and the opposing rotor hub. Teeter angles vary with airspeed, rates of descent, yaw rates, lateral cyclic, and roll or yaw rate reversals. As a general trend, blade-to-hub clearances decrease with decreasing airspeed, increasing rates of descent, and aggressive lateral cyclic or yaw pedal inputs (particularly control reversals).

Combining these elements which increase blade teeter angles can, under worst case conditions, result in blade-to-hub contact. This contact will be recognized by the pilot as a “bump” or series of “bumps” felt through the aircraft structure. Once a “bump” is felt, reducing the severity of the maneuver will immediately eliminate the high teeter angle condition. Aircraft structural integrity and flying qualities are not noticeably degraded as the result of such contact and will permit safe flight to the nearest suitable landing area to investigate for possible damage.

Minimizing yaw rate and/or rate reversals, as airspeed is reduced during high rates of descent, or high aircraft pitch attitudes, will significantly increase clearances and eliminate occurrences of blade-to-hub contact.

NOTE

All powered flight operations above 10,000 feet DA or operations at gross weights exceeding 6,500 lbs. will be performed at 104% N_R .

External Load Checklist

| | |
|------------------------------------|------------------------------------------|
| load meter | Test (Needle should indicate 5,000 lbs.) |
| rotor RPM | 104% |
| manual hook release | Check |
| HOOK ARM/SAFE | ARM |
| cyclic hook releases | Check |
| collective hook releases | Check |

CAUTION

Each external load is different (weight, size, shape, aerodynamics), and may require reduced maximum bank angles and/or airspeeds. Extreme caution must be utilized to ensure that the loads carried, and the speed range throughout which operations are intended, do not adversely affect the controllability characteristics of the helicopter.

CAUTION

While performing rapid deceleration or a steep descent with collective full down, and carrying an external load, add a small amount of collective prior to putting in a large amount of collective to stop the maneuver. This will “load up” the freewheeling unit. Abrupt collective inputs from an “unloaded” condition may cause accelerated wear of the freewheeling unit, resulting in premature removal. Leading with a small amount of collective input, anticipating the need for a rapid increase in collective, will increase the probability that the freewheeling unit is fully engaged when high power is applied.

NOTE

No minimum load required for cargo hook release.

Landing Procedure

Normal aircraft landing includes transition to a hover and a vertical landing. The landing corridor is depicted in the Height/Velocity diagram (Figure 5-10) in Section 5.

Shutdown Checklist

| | |
|--------------------|------------------------------------|
| nose wheel | Locked |
| parking brake | Set |
| throttle | FLT IDLE (2 min. engine cool down) |
| AVIONICS MASTER | OFF |
| SAS (if installed) | OFF |
| throttle | GND IDLE |
| droop stops | In (at approx. 40% NR) |
| throttle | OFF |

CAUTION

Do not stop rotors abruptly with rotor brake.

| | |
|-------------------------------------|-----------------------------------|
| rotor brake | On (apply with smooth, even pull) |
| GEN | OFF |
| FUEL/OIL | OFF |
| boost (if installed) | OFF |
| PART SEP | OFF |
| EGT on shutdown | Noted (decreasing) |
| RH switch panel switches | OFF/As desired |
| comm/nav radios | OFF |
| standby power switch (if installed) | OFF |
| BATT | OFF |

IFR Procedures

Preflight Procedures

Check all required equipment for normal operation. Arrange maps and publications for easy access in map case. Recommend cockpit doors be installed for IFR flight.

Each cockpit flood light may be moved from behind the pilot's head to the forward flood light holder (on the same side) on the forward door frame.

Inflight Procedures

Recommended IFR speeds:

1. Best rate of climb (Vy) 50 KIAS
2. Cruise 80 KIAS
3. Approach 75 KIAS

IFR Climb and descents have been demonstrated up to 1000 FPM. IFR precision approaches have been demonstrated at glideslopes up to 4 degrees.

Miscellaneous Procedures

Post-Flight Procedures

Following the last flight of the day, download engine HIT check, download all recorded operational data, and run instrument BIT by pressing instrument panel TEST switch.

Caution Panel Test Switch

The caution panel TEST switch will illuminate all segments on the caution/advisory panel. It will also illuminate the master caution panel and activate the built-in-test on the torque, load, EGT, and N_G indicators. It will also illuminate the lights on the external instrument panel.

The built-in-test feature of the torque, load, EGT, and N_G indicators includes a test of the limit light (solid red), the digital display (8-8-8-8), and an error code, if applicable, on each gauge.

Particle Separator

Use of the particle separator is recommended at all times. Flights with particle separator off are permitted in areas free of small particulate matter. The particle separator must be operated in sand/dusty areas, over salt water, and whenever conditions for icing exist. The particle separator was designed to operate continuously during flight. There are no inflight procedures that require turning off the particle separator. Turning off the particle separator provides less than 1 psi increase in available torque.

Cabin Heat/Vent

Cabin heat and ventilation is controlled by use of the CABIN HEAT/VENT switch located on the instrument panel. Temperature can be increased by pulling out on the cabin temperature knob located on the lower portion of the instrument panel. Adjusting airflow from defrost to cabin heat or a mixture of both can be accomplished by pulling out on the HEAT/DEFROST knob located on the lower portion of the instrument panel.

Engine Anti-Ice

Use of engine anti-ice is required in flight when the ambient temperature is $\leq 4^\circ\text{C}$ with visible moisture. It is activated by the ANTI ICE switch located on the switch panel.

Pitot Heat

Use of pitot heat is recommended in conditions of freezing temperatures and visible moisture.

Doors/Skids

There are no flight restrictions for any combination of cockpit doors, cargo doors, or skids removed.

Cold Weather Operations

During cold weather operations, expect initial engine and transmission oil pressures to be higher than normal until operating temperatures are reached. Do not take off until all temperatures and pressures are within the green arcs on the indicators. See Section 10 for additional information.

Hot Weather Operations

During hot weather operations, monitor engine and transmission pressures and temperatures to avoid exceeding any limitations. See Section 10 for additional information.

IFR Operations (IFR Equipped Aircraft)

The helicopter is fully instrumented and the navigation system is capable of providing the pilot with continuous range and bearing information from the helicopter's present position to a pre-selected base or destination position. The stability augmentation system (SAS) provides additional stability to the aircraft for IFR flight. Normal airway instrument flight may be accomplished within the limitations of the navigational equipment installed in the helicopter. Careful pre-flight planning, flight operations in accordance with the limitations set forth in this flight manual, and strict adherence to proper performance of minimum aircraft equipment, as specified in section 2, are mandatory.

Power Assurance Check

A power assurance check is recommended prior to shutdown (during last flight of the day), any time engine performance is in question, or when maintenance procedures indicate a requirement. See Section 5 for detailed procedures.

Section 4 Emergency Procedures

Contents

| | |
|-------------------------------------------------------|------|
| General | 4-2 |
| Powerplant failures | 4-3 |
| Engine fail – IGE hover | 4-4 |
| Engine fail – OGE hover | 4-4 |
| Engine fail during takeoff | 4-4 |
| Engine fail in cruise flight | 4-5 |
| Air restart | 4-5 |
| Fuel control malfunction – high side failure | 4-6 |
| Fuel control malfunction – low side failure | 4-6 |
| Fires | 4-7 |
| Engine fire in flight | 4-7 |
| Engine compartment fire during start | 4-7 |
| Hot start | 4-7 |
| Electrical fire (VFR) | 4-8 |
| Electrical fire (IFR) | 4-8 |
| Smoke and fume elimination | 4-9 |
| Post engine–shutdown fire | 4-9 |
| Electrical power failure procedures | 4-9 |
| Generator failure | 4-9 |
| Main battery failure (IFR equipped) | 4-10 |
| System failures | 4-10 |
| Rotor brake failure | 4-10 |
| Wheel brake failure | 4-10 |
| Nose wheel lock failure | 4-10 |
| Droop stop failure | 4-10 |
| Engine fuel pump failure | 4-11 |
| Single/dual fuel boost pump failure | 4-11 |
| Horizontal stabilizer failure | 4-11 |
| Emergency egress | 4-11 |
| Collective limiter failure | 4-12 |
| Increased downforce (collective pulling down) | 4-12 |
| Increased upforce (collective difficult to push down) | 4-13 |
| KAflex drive shaft partial failure | 4-13 |
| Cyclic boost system failure | 4-13 |

Contents (Continued)

| | |
|-----------------------------------------|------|
| SAS Failure | 4-13 |
| Uncommanded aircraft response | 4-14 |
| PCDS Emergency procedures | 4-14 |
| Cockpit indicating lights | 4-15 |

General

The procedures outlined in this section deal with the common types of emergencies; however, the actions taken in each actual emergency must relate to the complete situation. Extraordinary circumstances such as compound emergencies may require departures from the normal corrective procedures used for any specific emergency.

Throughout this section, the terms “land immediately,” “land as soon as possible,” and “land as soon as practical” are used to reflect the degree of urgency with which a landing must be made.

1. LAND IMMEDIATELY – Self explanatory
2. LAND AS SOON AS POSSIBLE – Land at the nearest site at which a safe landing can be made.
3. LAND AS SOON AS PRACTICAL – Extended flight is not recommended. The landing site and duration of the flight are at the discretion of the pilot.

Many of the malfunctions described in this section will be indicated by the lighting of warning or caution lights, the master caution light, and in some cases, a tone in the headset. Whenever a caution light goes on, the RESET pushbutton should be depressed to turn the master caution light off and reset it for another condition. An audio tone can be eliminated and reset for another condition by pressing the RESET pushbutton.

Any unusual change in aircraft noise, vibrations, or flight characteristics should be investigated immediately to determine an appropriate course of action. If the cause and procedure are not immediately obvious, a power-on landing should be made as soon as possible. External load operations should be discontinued, including jettison as required, until the aircraft has been thoroughly inspected and returned to normal service.

WARNING

In an emergency, the safety of persons on the ground is critical in deciding when to jettison the external load.

The procedures following any precautionary/autorotative landing should include engine shutdown (droop stops in, throttle OFF and FUEL/OIL switch OFF) and removing electrical power. The rotor brake should be used to stop the rotors and wheel/parking brakes applied as required. The pilot should immediately exit the aircraft.

Powerplant Failures

WARNING

During all engine failures or fires with an external load, the first procedure is to jettison the load. All devices, lines, and gear attached to the aircraft cargo hook must be jettisoned. Failure to jettison an external load during an emergency could result in catastrophic consequences.

WARNING

N₂ needle on dual tachometer indicator will not represent rotor speed during autorotations or engine failures.

NOTE

N_R tach generator failure will be indicated by the N_R needle dropping to zero while N₂ and the rotor system maintain the selected RPM. Monitor N₂/rotor speed and land as soon as practical.

Engine failure while carrying an external load will require immediate jettison of the load. Jettison must be at the airframe cargo hook. In any landing following engine failure, maximum survivability is achieved with a level landing attitude.

Engine Fail—IGE Hover

Level aircraft; stop any drift. Cushion landing with collective
wheel brakes As required
rotor brake As required
FUEL/OIL OFF
BATT OFF
Exit aircraft

Engine Fail—OGE Hover

load Jettison
airspeed Attempt to regain 45 KIAS
(Nose down attitudes of approximately
20 degrees are most effective)
at 50–75 ft. AGL Flare as required
at 10–15 ft. AGL Level aircraft. Cushion landing with col-
lective
wheel brakes As required
rotor brake As required
FUEL/OIL OFF
BATT OFF
Exit aircraft

Engine Fail During Takeoff

load Jettison
collective Freeze or reduce as required to maintain
75–100% N_R
airspeed 50 KIAS (minimum rate of descent)
65 KIAS (maximum range)
at 50–75 ft. AGL Flare as required
at 10–15 ft. AGL Level aircraft. Cushion landing with col-
lective
wheel brakes As required
rotor brake As required
FUEL/OIL OFF
BATT OFF
Exit aircraft

Engine Fail In Cruise Flight

load Jettison
collective Full down; enter autorotation
rotor speed Maintain 75–100%
airspeed 50 KIAS (minimum rate of descent)
 65 KIAS (maximum range)
 80 KIAS (V_{NE} power-off)
at 50–75 ft. AGL Flare as required
at 10–15 ft. AGL Level aircraft. Cushion landing with col-
lective
wheel brakes As required
rotor brake As required
FUEL/OIL OFF
BATT OFF
Exit aircraft

Air Restart

CAUTION

Do not attempt restart if engine malfunction is suspected or until safe auto-rotation is established. Restarts should not be attempted below 2000 ft. AGL.

When using Jet A, air restart is possible up to 8,000 ft. maximum (Jet B up to 20,000 ft.).

NOTE

Failure of automatic fuel control may require restart with emergency fuel selected and manual throttle control by the pilot.

BATT ON
FUEL/OIL ON
throttle GND IDLE
start trigger Pull and hold until 36% N_G. Monitor
EGT, N_G rpm, transmission oil pressure,
and engine oil pressure
throttle Full open

Fuel Control Malfunction – High Side Failure

Loss of N₂ sensing results in a loss of power turbine speed signal to the engine fuel control and possibly to the cockpit indicator. The fuel control will attempt to increase N₂ which is now sensed as zero. This condition will be recognized as an increasing N_R accompanied by increasing N_G (N₁) and EGT.

collective Increase as required/available to control N_R
throttle Reduce as required to control N₂/N_R
load Jettison as required
GOV EMERG
throttle Adjust as required
rotor speed Maintain 98–102%
aircraft Land as soon as practical

Fuel Control Malfunction – Low Side Failure

NOTE

N₂ tach generator failure will be indicated by the N₂ needle dropping to zero while N_R maintains the selected RPM. Monitor N_R and land as soon as practical.

An internal failure of the engine fuel control can cause a decrease or fluctuation in N₂ (N_P). This condition will be recognized as a decreasing or fluctuating N_R accompanied by decreasing or fluctuating N_G (N₁) and EGT.

load Jettison as required
throttle FLT IDLE
GOV EMERG
throttle Adjust as required
rotor speed Maintain 98–102%
aircraft Land as soon as practical

Fires

Engine Fire in Flight

| |
|----------------|
| WARNING |
|----------------|

Maintain autorotational capability pending possible engine failure. The severity of the fire may require engine shutdown prior to landing.

- load Jettison
- aircraft Land as soon as possible
- after landing:
- throttle OFF
- FUEL/OIL OFF
- rotor brake Apply
- BATT OFF
- Exit aircraft

Engine Compartment Fire During Start

- throttle OFF
- FUEL/OIL OFF
- rotor brake Apply
- EXT PWR OFF, if connected
- BATT OFF
- Exit aircraft

Hot Start

- throttle OFF; continue motoring engine with start trigger and START TST switch
- Starter continue to motor until EGT decreases
- EGT Gauge Check for peak temp
- If temp limit not exceeded: allow engine to cool down prior to subsequent start attempt.
- If temp limit exceeded:
- FUEL/OIL OFF
- EXT PWR OFF, if connected
- BATT OFF
- Exit aircraft

Electrical Fire (VFR)

load Jettison as required
GEN OFF
BATT OFF
Standby battery/power supply OFF (if installed)
aircraft Land as soon as possible
after landing:
throttle OFF
wheel brakes As required
rotor brake As required
portable extinguisher Extinguish fire (time permitting)
Exit aircraft

Electrical Fire (IFR)

WARNING

Failure to extinguish an electrical fire prior to landing will require performing the “after landing” procedures for Electrical Fire (VFR).

NOTE

Perform normal shutdown procedure if fire extinguished.

If able to immediately identify source of fire:

Turn affected equipment off and pull applicable circuit breakers.

Aircraft land as soon as practical/possible as the situation dictates

If unable to immediately identify source of fire:

Generator, BATT OFF

non-essential electrical equipment OFF

BATT ON

If fire is still not evident:

Generator ON

necessary electrical equipment ON (one at a time)

Aircraft land as soon as practical/possible as the situation dictates

If fire/smoke/fumes return as equipment is turned on, turn affected equipment off and pull applicable circuit breakers. In actual IMC flight the pilot should attempt to regain and maintain VMC flight until landing.

Smoke and Fume Elimination

all windows Open
aircraft Slight right side slip (left yaw) to facilitate
smoke and fume removal

Post Engine-Shutdown Fire

If EGT rises after engine shutdown, proceed as follows:

throttle OFF
FUEL/OIL ON
START/TEST START

NOTE

The FUEL/OIL switch must be on for starter to engage. Observe starter limitations.

start trigger Motor engine until EGT decreases

Electrical Power Failure Procedures

NOTE

Complete failure of the electrical system is unlikely because the primary power, normally supplied by the generator, will be furnished by the battery in the event of a generator failure. Evidence of a generator failure will be indicated by illumination of the GENERATOR caution light with the ammeter at zero. In the IFR configuration, with a generator and main battery failure, power will be supplied by the standby battery/power supply to the standby bus for flight critical instruments and lighting.

Generator Failure

CAUTION

In the event of a main generator failure and low battery voltage, the aircraft instruments/systems may partially fail or become unreliable prior to complete failure. For the IFR configuration, the standby battery will continue to power the standby instruments/ systems for approximately 1 hour after the battery light illuminates.

NOTE

Minimize use of all non-essential equipment and lighting (internal/external) with a generator failure.

Move generator switch to reset and then on. If power returns, continue flight, otherwise, land as soon as practical and avoid IMC flight. In the event of a generator failure the main battery is capable of providing all aircraft electrical power for approximately one hour.

Main Battery Failure (IFR Equipped)

During flight, illumination of a BATTERY light indicates battery failure or low voltage (<18 volts). Avoid or minimize flight in IMC. If VMC, inspect battery after landing. In the IFR configuration, in the event of a generator and main battery failure, the standby battery/power supply will provide electrical power for up to 60 minutes to the equipment on the standby electrical bus, depending on battery condition and electrical load.

System Failures

Rotor Brake Failure

aircraft Position into prevailing wind
cyclic Position slightly into wind
aircraft Perform normal shutdown, ensuring
droop stops are engaged prior to securing
engine

Wheel Brake Failure

aircraft Land on level surface
wheels Chock both main wheels
aircraft Perform normal shutdown

Nose Wheel Lock Failure

aircraft Limit ground operations to 10 knots or
less

Droop Stop Failure

CAUTION

Severe damage may result, especially during windy conditions, if droop stops remain out at low RPM. If droop stops are not in at GND IDLE, proceed as follows:

throttle FLT IDLE (or FLY, as necessary)
throttle GND IDLE

NOTE

If droop stops still do not engage, have ground crew use soft end of a long-handled broom to engage stops prior to engine shutdown.

Engine Fuel Pump Failure

External load operations Terminate
Aircraft Land as soon as possible

Single/Dual Fuel Boost Pump Failure

WARNING

Maximum aircraft pitch attitude with any inoperative boost pump is limited to ± 10 degrees above 300 pounds remaining. Maintain level aircraft pitch attitude with fuel less than 300 pounds remaining.

CAUTION

Dual boost pump failure can be identified by illumination of both FWD Pump and AFT Pump caution lights (Before SB 075) or illumination of the Fuel Boost Pump caution light (After SB 075) accompanied by an indication of zero pressure on the fuel pressure gauge. Dual boost pump failures have not been demonstrated above 12,000 ft. DA or at torque settings above 25 PSI. Therefore, in the event of a dual boost pump failure, limit torque to 25 PSI and descend below 12,000 ft. if able. If low fuel light illuminates with a dual boost pump failure, limit roll attitude to 15 degrees and minimize pitch attitude changes.

NOTE

A fuel boost pump caution light may illuminate at low fuel conditions (<400 lbs) with changes in aircraft pitch attitude. Return the aircraft to a level attitude to extinguish the caution light.

external load operations Terminate
If fuel quantity < 300 lbs remaining Land as soon as possible
If fuel quantity > 300 lbs remaining Land as soon as practical

Horizontal Stabilizer Failure

NOTE

Failure of horizontal stabilizer may result in increased pitch attitude changes with power changes.

airspeed 50 KIAS maximum
aircraft Land as soon as possible

Emergency Egress

The pilot may exit through either door in an emergency. Preferred exit is through right door, using steps.

Collective Limiter Failure

CAUTION

Loss of supply fluid to the collective limiter can cause the collective to rise while the aircraft is turning on the ground with the throttle in fly position. This could result in the aircraft becoming airborne if the collective is not held down.

CAUTION

Monitor transmission oil temperature, pressure, and oil level if collective limiter failure is suspected.

Collective limiter failures can be characterized by an increase in force required to move the collective up, down, or hold it in a given position. This failure can be caused by a problem with the balance spring and/or a loss of fluid supply to the limiter.

In the event of a loss of fluid supply to the collective limiter while the aircraft is on the ground, the collective will want to rise with a rotor rpm (N_R) greater than approximately 80%. The required force to hold the collective down in this condition will increase as rotor rpm increases. Loss of supply fluid in a hover will also cause the collective to rise, requiring the pilot to push down on the collective to hold it in position. The amount of force required to stop the collective from rising will depend on rotor rpm and the required collective position. The higher the collective position, the lower the required force to hold it there. As the airspeed is increased from hover to forward flight, the force to hold the collective down decreases. This is due to the requirement for a higher collective setting and decreased downwash on the horizontal stabilizer. The collective forces for an aircraft weighing 6000 lbs will balance in level flight at approximately 90 KIAS. At this airspeed, descents will require holding a downward force on the collective, while climbing flight will require an upward force.

Following a collective limiter failure, adjust rotor rpm (N_R) to reduce collective forces. Collective friction may be used to hold the collective in a position for extended flight, but should be reduced for landing. Approaches to landing should be planned for a running or no-hover landing utilizing minimal collective inputs. Should a hover landing be required, stabilize the aircraft at a higher than normal hover height to ensure safe obstacle clearances prior to landing.

In the event of collective limiter failure:

- Collective drives up Decrease rotor RPM (N_R)
- Collective drives down Increase rotor RPM (N_R)
- aircraft Land as soon as practical/possible as situation dictates

Increased Downforce (Collective Pulling Down)

Beep N_R Maximum for flight

Increased Upforce (Collective Difficult to Push Down)

Beep N_R Minimum for flight

CAUTION

Monitor transmission oil temperature, pressure, and oil level if collective limiter failure is suspected.

KAflex Drive Shaft Partial Failure

Partial failure of a driveshaft flex frame will be identified by a medium- to high-frequency vibration in the airframe.

external load operations Terminate
aircraft Land as soon as possible

Cyclic Boost System Failure

NOTE

Boost failure will cause pitch and roll SAS to be disabled. Pitch and Roll SAS may not fail in neutral positions. Reduced control margins may exist. Make all landings to a level surface into the wind.

Boost switch OFF
SAS Pitch and Roll switches OFF (if installed)
VMC Land as soon as practical
IMC Transition to VMC as soon as practical

SAS Failure

NOTE

Loss of any SAS channel/ actuator may result in reduced control capability. Make all landings to a level surface into the wind.

Affected channel(s) Identify
Affected channel(s) OFF
VMC Land as soon as practical
IMC Transition to VMC as soon as practical

Uncommanded Aircraft Response

CAUTION

SAS actuator failure at the limit of actuator travel may result in the loss of 15% longitudinal, 12% lateral, or 11% directional authority.

SAS Disable switch ENGAGE
Affected SAS channel OFF
SAS Disable switch DISENGAGE
VMC Land as soon as practical
IMC Transition to VMC as soon as practical

PCDS Emergency Procedures

General PCDS Egress

In the event of an emergency, the occupant will remain seated until the aircraft has landed and all motion of rotors has stopped.

PCDS Restraint System Failure

NOTE

Failure of AA12-001 audio panel will disable the PCDS intercom system and will preclude ICS communications between pilot and crew.

In the unlikely event one of the two restraint systems fails, the occupant will notify the pilot immediately. The pilot will slow the aircraft and land as soon as possible.

Cockpit Indicating Lights

The following tables provide cockpit indicating light definitions and scenarios:

1. Cockpit Master warning and caution lights – Table 4-1
2. Cockpit Indicating lights requiring landing as soon as possible – Table 4-2
3. Cockpit Indicating lights requiring landing as soon a practical – Table 4-3
4. Cockpit Indicating lights requiring immediate pilot action – Table 4-4
5. Cockpit Advisory lights – Table 4-5

Table 4-1. Cockpit Master Warning and Caution Lights

| Legend | Meaning |
|-----------|------------------------------------------------------------------------------------------------------------------------------------------------------------------------------------------------------------------------------------------------------------------------------------------|
| ROTOR | Rotor RPM 75-88±1% or >107±1%; aural and visual warning. If >105%, control with collective and throttle; engine RPM switch may be used. Inspection and component replacement required if RPM >120%. If <100%, reduce collective, <u>jettison load</u> , enter autorotation if necessary. |
| FIRE | Engine compartment fire. See fire checklists. |
| MAST CAUT | One or more caution lights illuminated. Check caution/advisory light panel; press RESET switch to extinguish master caution light or audio warning. |

Table 4-2. Cockpit Indicating Lights Requiring Landing as soon as Possible

| Legend | Meaning |
|-------------|---------------------------------------------------------------------------------------------|
| XMSN CHIP | Possible transmission deterioration. Press FUZZ BURN. If light continues, land and inspect. |
| XMSN PRESS | Low transmission oil pressure. Land and inspect. |
| XMSN TEMP | High transmission oil temperature. Reduce transmission load; land and inspect. |
| XMSN BYPASS | Impending oil filter bypass. Land and inspect. |
| XMSN LOW | Transmission oil level low. Land and inspect. |
| ENG CHIP | Possible engine deterioration. Press FUZZ BURN. If light continues, land and inspect. |
| ENG PRESS | Low engine oil pressure. Land and inspect. |

Table 4-2. Cockpit Indicating Lights Requiring Landing as soon as Possible (Continued)

| Legend | Meaning |
|---------------|----------------------------------------------------------------------------------------------------------------------------------------------------------------------------------------------------------------------------------------------------------------------------------------------------------------|
| ENG TEMP | High engine oil temperature. Reduce engine power; land and inspect. |
| ENG FUEL PUMP | After SB 075, one engine fuel pump element inoperative, land and inspect; a second pump element failure will result in engine failure. |
| OIL VALVE | Oil valve not corresponding to switch position. Land and inspect. |
| ENG LOW | Engine oil level low. Land and inspect. |
| LOW FUEL | 100±15 lbs (Jet A) (approx. 10 minutes) usable fuel remaining (level attitude) utilizing a power setting not to exceed 28 PSI torque. Land and refuel. Roll attitude limited to ±15° bank angle with light illuminated. Avoid unbalanced flight and large pitch attitudes. Terminate external load operations. |
| FUEL BYPASS | Impending fuel filter bypass. Land and inspect. |
| FUEL VALVE | Fuel valve not corresponding to switch position. Land and inspect. |

Table 4-3. Cockpit Indicating Lights Requiring Landing as soon as Practical

| Legend | Meaning |
|-----------------|----------------------------------------------------------------------------------------------------------------------------------|
| FWD PUMP | Before SB 075, forward fuel pump inoperative. Land and inspect. |
| AFT PUMP | Before SB 075, aft fuel pump inoperative. Land and inspect. |
| FUEL BOOST PUMP | After SB 075, one or both boost pumps failed. Check fuel pressure gauge for boost pump pressure. Land and inspect. |
| GENERATOR | Generator inoperative. Press GEN RESET. If light continues or repeats, place GEN switch OFF. "See electrical failure procedures" |

Table 4-4. Cockpit Lights Requiring Immediate Pilot Action

| Legend | Meaning |
|-------------|------------------------------------------------------------------------------------------------------------------------------------------------------------------------------------------------------------------------------------------------------------------------------------------|
| TORQUE | Overtorque condition exists. Reduce torque; land and inspect if BIT ball indicated in torque gauge. |
| ENG ICE | Engine inlet temperature $\leq 7^{\circ}\text{C}$. Engine anti-ice is required at or below 4°C in visible moisture. |
| BOOST PRESS | After SB 070. Cyclic boost pressure low. Secure pitch and roll SAS systems then boost system. Minimize flight time in IMC. Land as soon as practical. |
| PITCH SAS | After SB 071. Longitudinal SAS failure. Secure system and minimize flight time in IMC. Reduced control margins are possible. Make all landings on level surface into wind. Land as soon as practical. |
| ROLL SAS | After SB 071. Lateral SAS Failure. Secure system and minimize flight time in IMC. Reduced control margins are possible. Make all landings on level surface into wind. Land as soon as practical. |
| YAW SAS | After SB 071. Directional SAS failure. Secure system and minimize flight time in IMC. Reduced control margins are possible. Make all landings on level surface into wind. Land as soon as practical. |
| BATTERY | After SB 071. IFR configuration only. Aircraft is receiving external electrical power when on ground. Light on during flight indicates battery low voltage (<18 volts) or failure. Avoid or minimize flight in IMC. Backup electrical capability reduced. Inspect battery after landing. |

Table 4-5. Cockpit Advisory Lights

| Legend | Meaning |
|-----------|--------------------------------------------------------------------------------|
| ENG DEICE | Engine anti-ice system is activated. |
| EXT PWR | Aircraft is receiving external electrical power. Non-IFR equipped aircraft. |

Section 5 Performance Data

Contents

| | |
|----------------------------------------------------------------------------------------------|------|
| Power assurance | 5-2 |
| Description | 5-2 |
| Sample calculation | 5-3 |
| Power available | 5-3 |
| PCDS performance data | 5-3 |
| Height-velocity diagram | 5-3 |
| Performance Data Illustratiuons | 5-3 |
| Density Altitude (Figure 5-1) | 5-4 |
| Power Assurance – Torque Correction (Figure 5-2) | 5-5 |
| Power Assurance Chart (Figure 5-3) | 5-6 |
| Power Available – Takeoff Power vs. Temperature (100% N _R) (Figure 5-4) | 5-7 |
| Power Available – Takeoff Power vs. Temperature (104% N _R) (Figure 5-5) | 5-8 |
| Power Available – Hover Ceiling 104% N _R (Figure 5-6) | 5-9 |
| Power Required – IGE Hover (104% N _R) (Figure 5-7) | 5-10 |
| Power Required – OGE Hover (104% N _R) (Figure 5-8) | 5-11 |
| Prevailing Wind Envelope (Figure 5-9) | 5-12 |
| Height/Velocity Diagram (Figure 5-10) | 5-13 |
| Maximum Rate of Climb (Figure 5-11) | 5-14 |
| Autorotation Glide Distance (Figure 5-12) | 5-15 |
| Density Altitude vs. Airspeed (Figure 5-13) | 5-16 |
| Indicated Airspeed vs. Calibrated Airspeed (Figure 5-14) | 5-17 |

Power Assurance

Description

The Honeywell approved engine power assurance check requires the pilot to select a target torque between 20 and 40 PSI, correct for the engine data plate torque value, and compare the cockpit EGT with the chart value for EGT. A cockpit EGT less than the chart EGT ensures an acceptable power assurance check. The following procedure is used to determine power assurance:

NOTE

Particle separator and generator on, cabin heat/anti-ice off.

Cockpit procedure:

1. Set 100% rotor speed.
2. Set cockpit target torque.
3. Note PA and OAT.
4. Record cockpit EGT at target torque value.
5. Obtain chart torque from Figure 5-2 or cockpit placard.
6. Enter power assurance chart (Figure 5-3) with chart torque; move right to pressure altitude, then down to ambient temperature, then left to chart EGT.
7. Cockpit EGT less than chart EGT is an acceptable power assurance check. Consult engine maintenance manual for a failed power assurance check.

Sample Calculation (Refer to Figures 5-2, 5-3)

| | |
|-----------------------------------------------------------------|-----------|
| cockpit target torque | 35 |
| data plate torque | 48.5 |
| chart torque | 34.3 |
| pressure altitude | 4,000 ft. |
| temperature | 20°C |
| cockpit measured EGT | 565°C |
| chart EGT | 610°C |
| cockpit EGT less than chart EGT = satisfactory power assurance. | |

Power Available

Description

The power available charts (Figures 5-4, 5-5, and 5-6) include engine installation losses, particle separator operating, and account for a minimum specification engine. Table 5-1 depicts the approximate power requirements associated with other bleed air configurations.

Table 5-1. Power Requirements

| System | Change in Power Available |
|--------------------------|---------------------------|
| Cabin heat – ON | -1.3 PSI Q (30 HP) |
| Engine anti-ice – ON | -9.3 PSI Q (216 HP) |
| Particle separator – OFF | +1.3 PSI Q (30 HP) |

Actual engine performance may be conservatively calculated with the power assurance check and the power available charts. These power assurance checks should be performed at the operating altitude of the aircraft. A satisfactory power assurance check, “cockpit EGT” less than the “chart EGT,” indicates an engine better than minimum specifications at that operating condition. For each 10°C (cockpit EGT < chart EGT), a correction factor of +3 psi torque may be added to the “Power Available” chart results. Power available results, plus the correction factor, may never exceed 58 psi torque. Torque, N_G , and EGT limits must be maintained regardless of engine capability.

PCDS Performance Data

The PCDS has minimal affect on aircraft performance. A small increase in drag and power required (2-3psi) would be noted with a person in the PCDS.

Height-Velocity Diagram

The Height-Velocity diagram (Figure 5-10) uses factors of airspeed and height above ground to represent areas where aircraft damage or injury may occur in the event that an autorotation has to be accomplished. The clear areas shown represent regions where extended operations should be avoided. They do not represent limitations. The aircraft gross weight used to define the diagram was 6500 lbs.

Performance Data Illustrations

Figures 5-1 through 5-14 illustrate pertinent performance data.

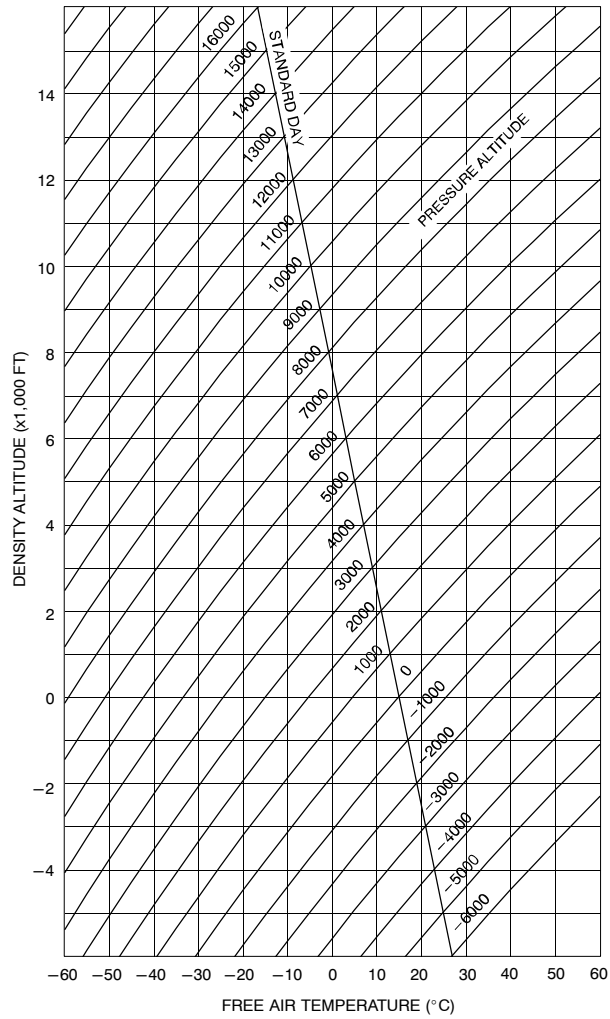

Figure 5-1. Density Altitude

Kaman K-1200
FAA Approved Rotorcraft Flight Manual

| | | ENGINE DATA PLATE TORQUE | | | | | | |
|--------------------------|----|--------------------------|------|------|------|------|------|------|
| | | 44.5 | 45.5 | 46.5 | 47.5 | 48.5 | 49.5 | 50.5 |
| COCKPIT INDICATED TORQUE | 20 | 21.3 | 20.9 | 20.4 | 20 | 19.6 | 19.2 | 18.8 |
| | 25 | 26.7 | 26.1 | 25.5 | 25 | 24.5 | 24.0 | 23.5 |
| | 30 | 32.0 | 31.3 | 30.6 | 30 | 29.4 | 28.8 | 28.2 |
| | 35 | 37.4 | 36.5 | 35.8 | 35 | 34.3 | 33.6 | 32.9 |
| | 40 | 42.7 | 41.8 | 40.9 | 40 | 39.2 | 38.4 | 37.6 |
| | 45 | 48.0 | 47.0 | 46.0 | 45 | 44.1 | 43.2 | 42.3 |
| | 50 | 53.4 | 52.2 | 51.1 | 50 | 49.0 | 48.0 | 47.0 |

Figure 5-2. Power Assurance – Torque Correction

Kaman K-1200
 FAA Approved Rotorcraft Flight Manual

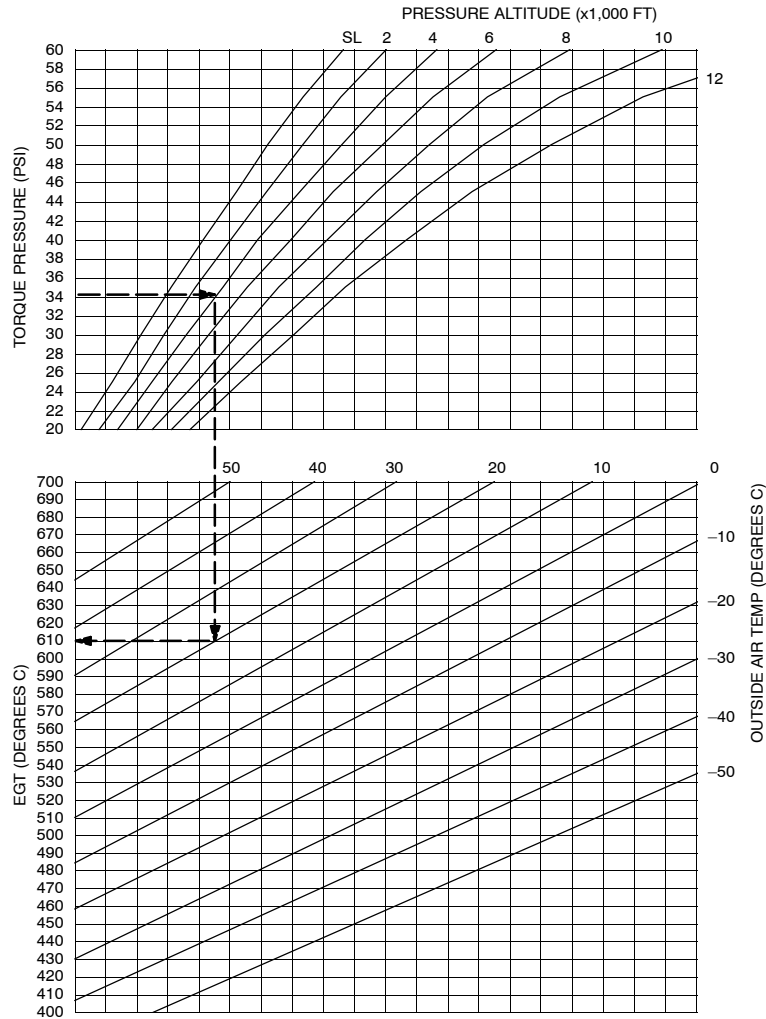

Figure 5-3. Power Assurance Chart

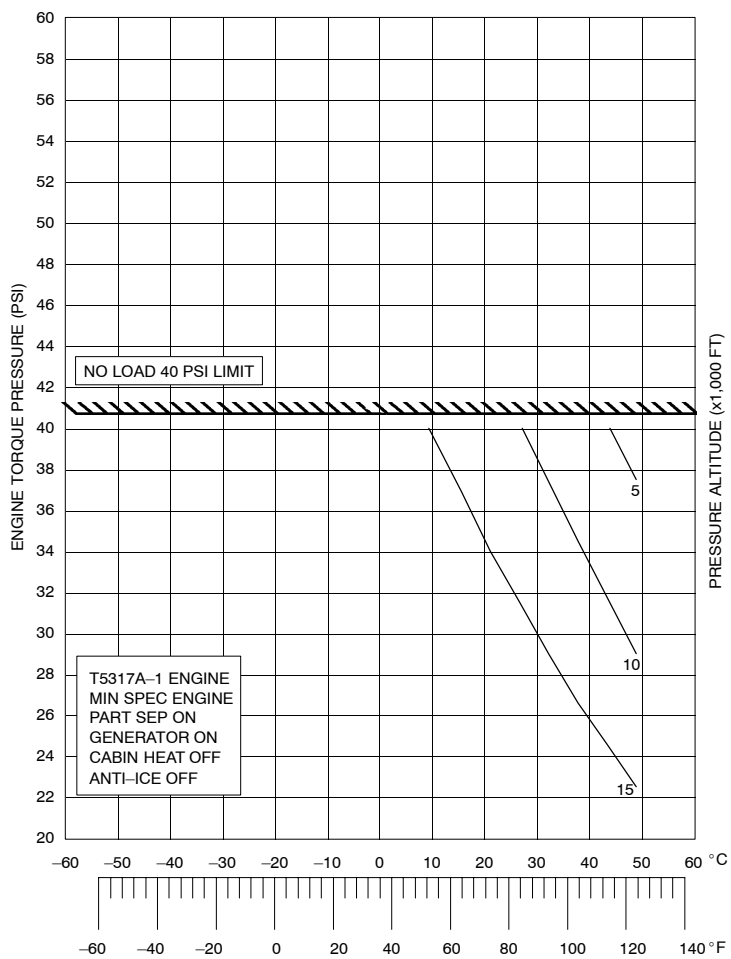

Figure 5-4. Power Available – Takeoff Power vs. Temperature (100% NR)

Kaman K-1200
 FAA Approved Rotorcraft Flight Manual

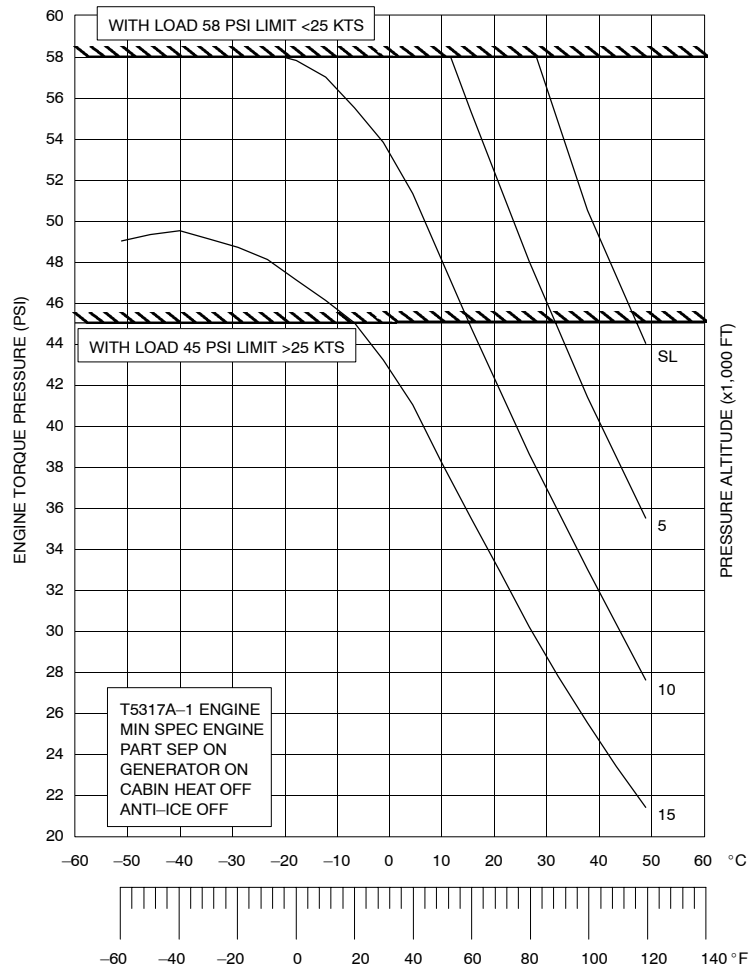

Figure 5-5. Power Available – Takeoff Power vs. Temperature (104% N_R)

Kaman K-1200
FAA Approved Rotorcraft Flight Manual

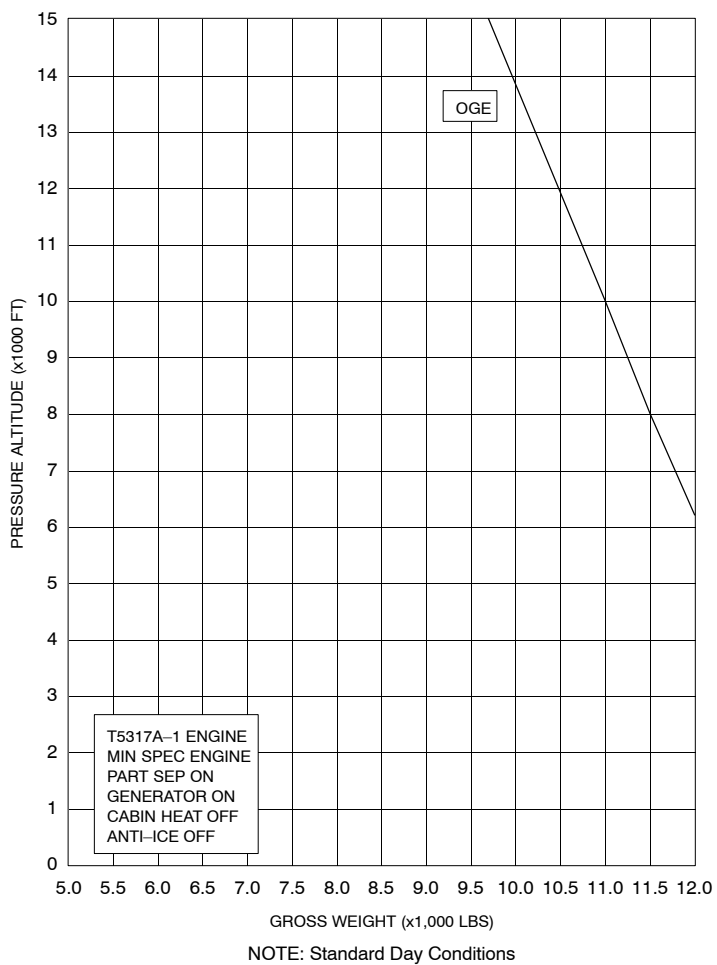

Figure 5-6. Power Available – Hover Ceiling (104% N_R)

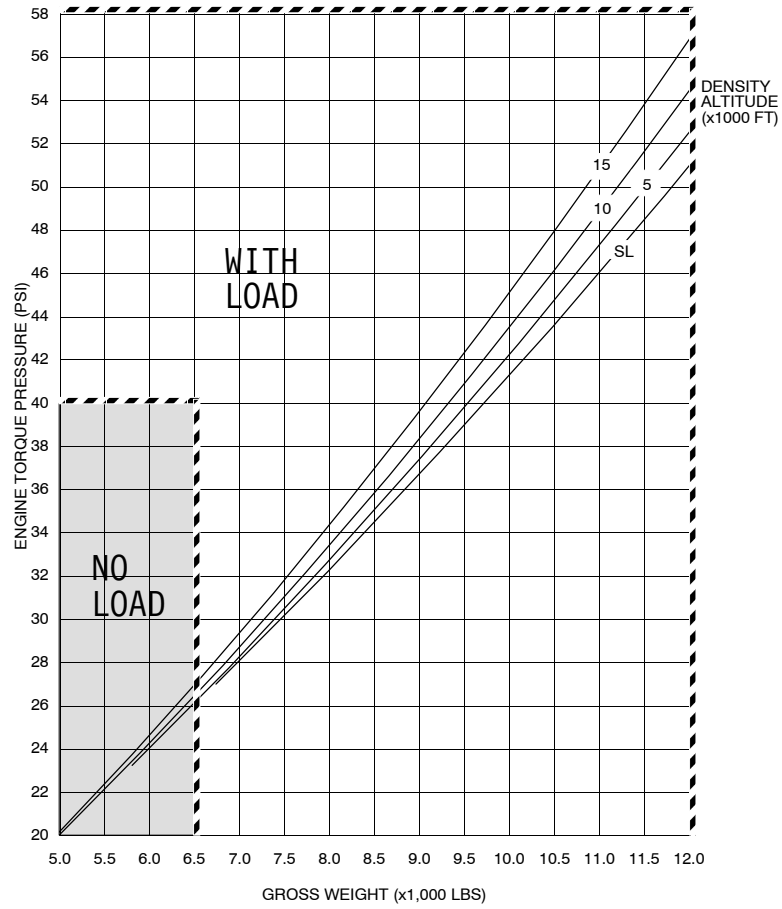

Figure 5-7. Power Required – IGE Hover (104% NR)

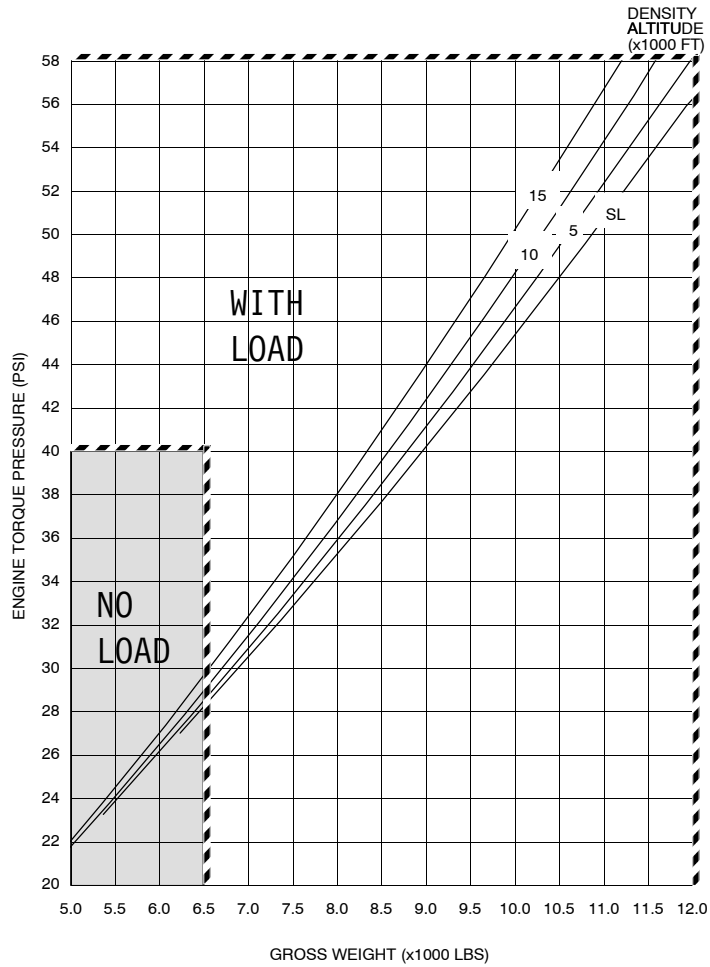
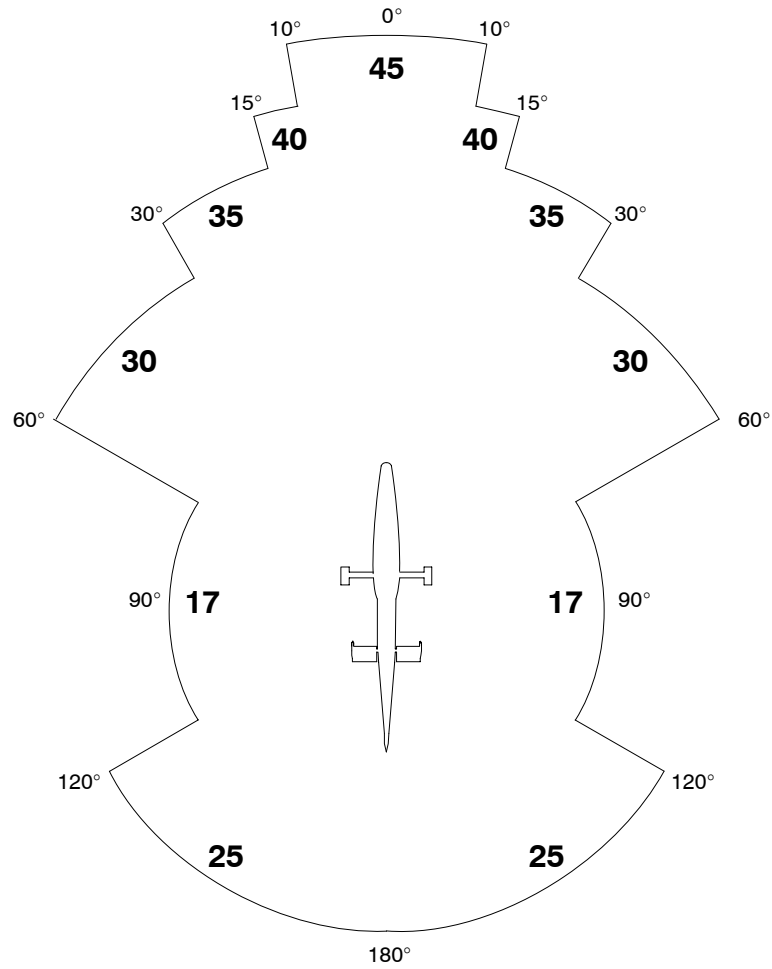

Figure 5-8. Power Required – OGE Hover (104% NR)



Bold Numbers = Max Kts

NOTE

THIS IS THE DEMONSTRATED WIND ENVELOPE
FOR TAKEOFF AND LANDING

Figure 5-9. Prevailing Wind Envelope

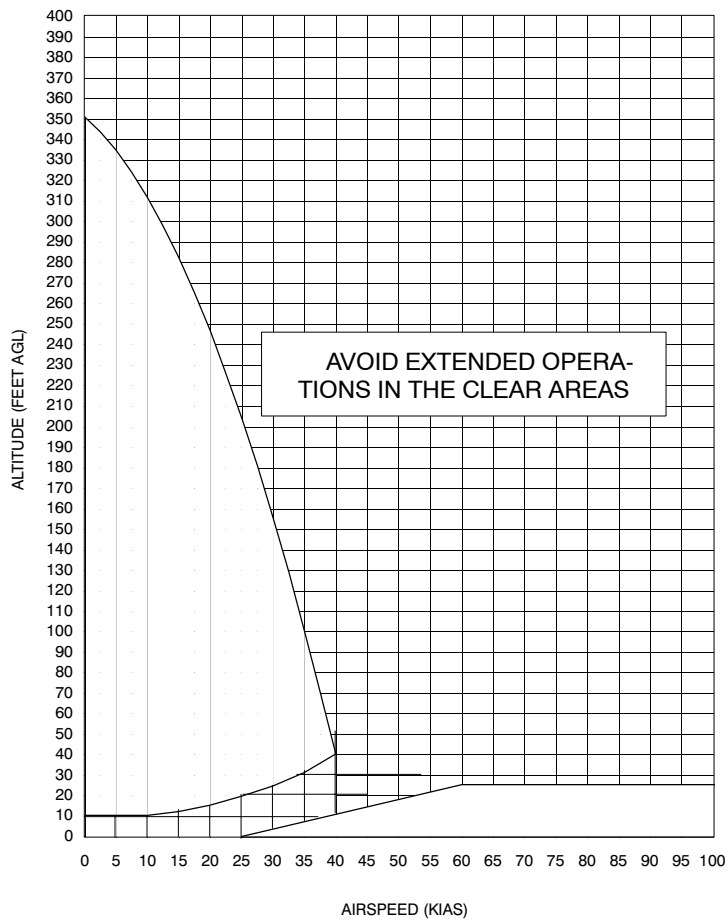

THE HEIGHT-VELOCITY DIAGRAM WAS DEMONSTRATED
TO A HARD PREPARED SURFACE.

Figure 5-10. Height/Velocity Diagram

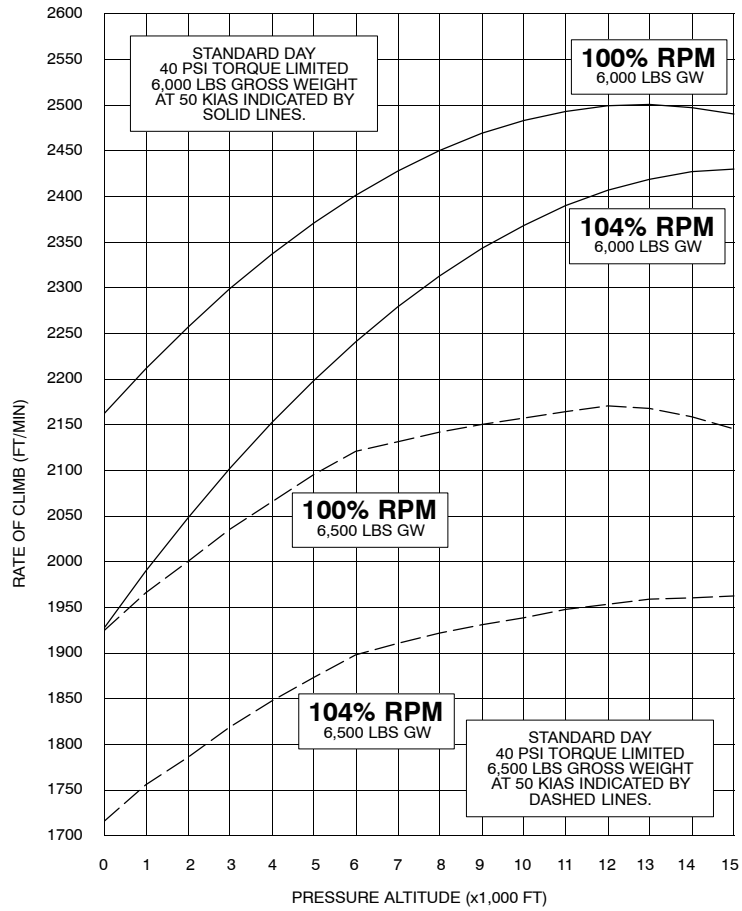
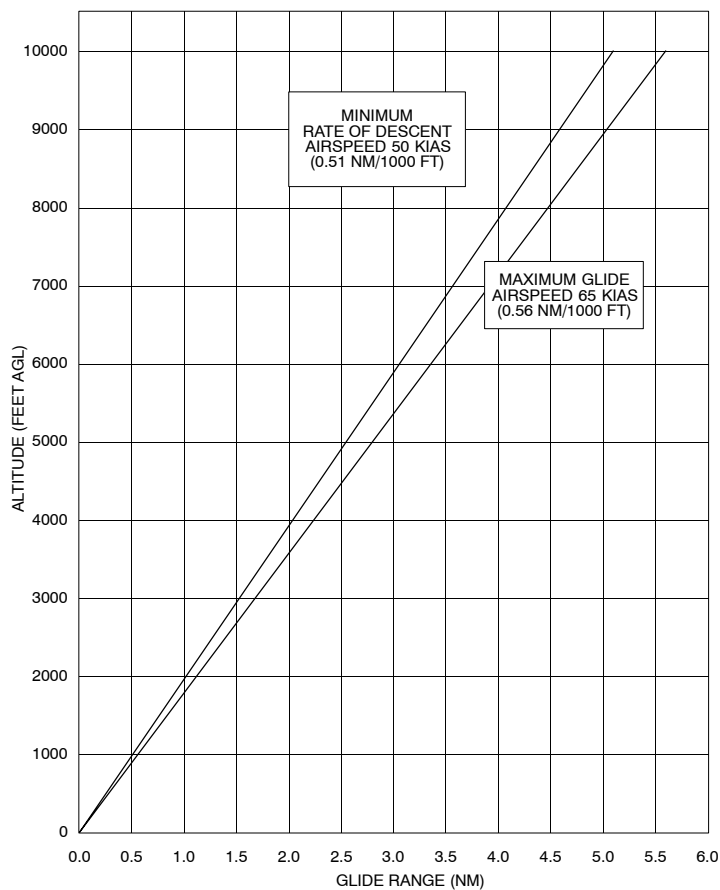

Figure 5-11. Maximum Rate of Climb



NOTE

MINIMUM RATE OF DESCENT RPM OR MAXIMUM GLIDE RPM IS
DEPICTED IN SECTION 10 AUTOROTATIONAL CHART RPM
MINIMUM AUTOROTATIONAL RPM IS 75%

Figure 5-12. Autorotation Glide Distance

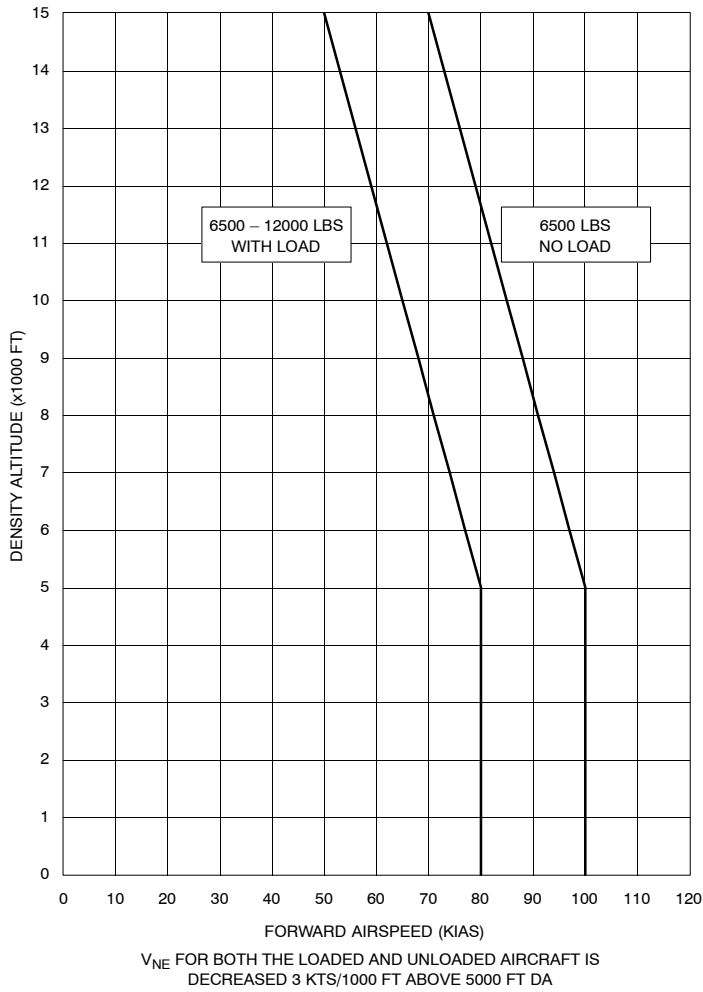

Figure 5-13. Density Altitude vs. Airspeed

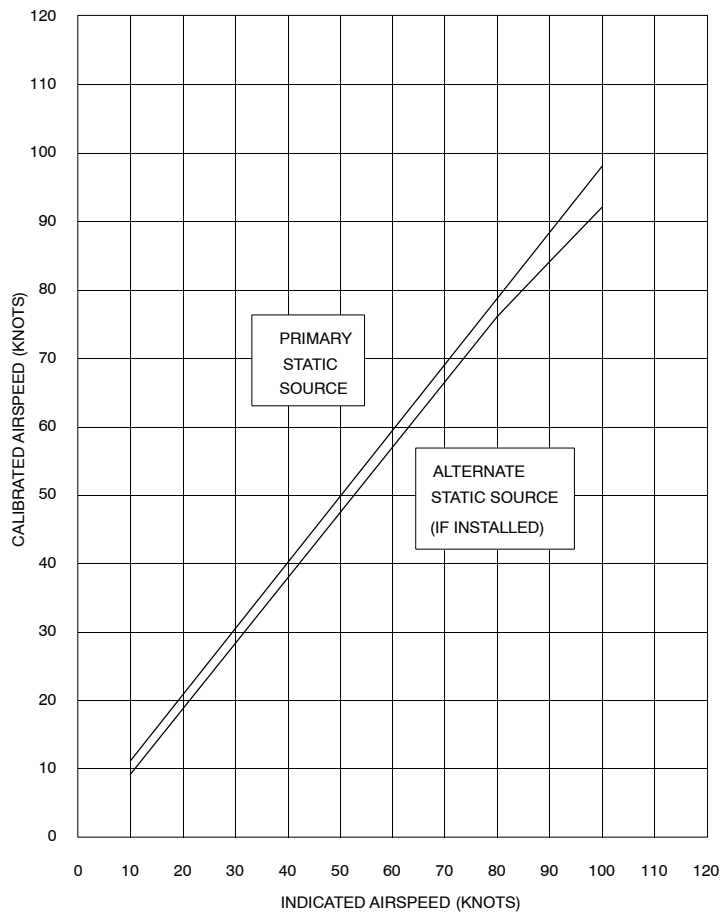

Figure 5-14. Indicated Airspeed vs. Calibrated Airspeed

Section 6 Optional Equipment

Contents

| | |
|-------------------------------------------|-----|
| Personnel Carrying Device System | 6-2 |
| Descriptive Data | 6-2 |
| Normal Procedures | 6-2 |
| Cyclic Boost System | 6-3 |
| Stability Augmentation System (SAS) | 6-3 |
| System Description | 6-3 |
| System Operation | 6-3 |
| Pitch SAS | 6-4 |
| Roll SAS | 6-4 |
| Yaw SAS | 6-4 |
| SAS caution lights | 6-4 |
| SAS actuators | 6-5 |
| SAS disable switch | 6-5 |
| Forestry Beacon | 6-5 |

Personnel Carrying Device System

The Personnel Carrying Device System (PCDS) is a single person external seat-like device that can be mounted on either side of the K1200 fuselage. The PCDS(s) may be installed on either or both sides. It is removable or foldable. When seated, the occupant faces in a lateral outward direction. The PCDS can only be used for the carriage of essential crew and for Part 133 operations.

The PCDS is constructed of aluminum and aluminum tubing. A "U" shaped round aluminum tube forms the footrest. The PCDS is secured onto the side of the aircraft by an upper and lower mount. It is installed by sliding the upper mount of the PCDS over the pins of the fuselage fitting, and then swinging the lower mount between the lugs located on the outboard portions of the trolley assembly and inserting a pin assembly. This pin is then latched in place using an over center latch. Additionally, a safety pin is inserted through the pin to ensure that the over center latch is positively locked. The PCDS is removed in the reverse order and can be folded flat for storage.

A five-point harness and a redundant lap belt secure the occupant while seated. There are no provisions for carrying cargo or equipment on the PCDS.

An intercom system (ICS) is provided for each occupant. The ICS connectors for the PCDS are located just forward of the main landing gear jacking points. The ICS is integrated into the standard aircraft ICS system. A press-to-talk switch is provided on the ICS cord for each PCDS occupant.

Being a fixed structure, class A external load, there are no provisions for a quick release or jettison system.

Descriptive Data

PCDS back length: 33.6 inches

PCDS pan length: 18.2 inches

Weight: 25 pounds per seat

Normal Procedures

Prior to takeoff assure that the PCDS inspection has been completed, and the occupant's five-point harness and lap belt are secured around the occupant. Establish positive ICS communication.

With a 300-pound person on only one side of the aircraft, the cyclic stick will be displaced laterally approximately one inch in a hover. This displacement reduces with forward speed. There is no adverse effect on handling qualities. The size/shape of the person may increase parasite drag and result in a small (2-3PSI) increase in power required for level flight.

Cyclic Boost System

The hydraulic boost system consists of a 1500 PSI hydraulic pump located and driven on an accessory pad of the main transmission, a hydraulic supply tank, supply and return filters, a pressure transducer and a pressure switch, relief valves, and external connections for ground servicing. Hydraulic power to the control actuators is provided through a manifold to the actuators and is regulated to 350 PSI.

The three actuators are located on the lateral cyclic control rod and the two longitudinal cyclic control rods located in the cargo compartment on the bulkhead closest to the pilot.

Should the actuators or the hydraulic system fail, the control or controls affected will continue to operate with slightly higher control forces.

Stability Augmentation System (SAS)

System Description

The SAS is an analog, 28 VDC, three-axis design for the pitch, roll, and yaw axes of the aircraft. Pitch and roll are implemented in the cyclic control system and yaw is stabilized with the rudder system. The SAS incorporates a SAS controller, vertical gyro, SAS actuators, control panel, caution lights, and a SAS Disable switch. The SAS controller and vertical gyro are in the nose compartment. The pitch actuator is located on the right side of the control module under the cockpit floor. The roll actuator is at the upper portion of the lateral cyclic control rod located at the forward end of the cargo area. The yaw actuator is located in the tail. A three-axis control panel is located on the right switch panel in the cockpit and provides individual control for pitch, roll, and yaw systems and incorporates a light to indicate power to the SAS controller. A SAS Disable switch is a lighted pushbutton located on the collective control head.

System Operation

The SAS controller and the vertical gyro are powered when power is applied to the aircraft. Power to these items can be disconnected by activating the SAS Disable switch on the collective. The SAS controller performs a power on reset (approximately 6 seconds) any time power has been interrupted to the SAS system. The vertical gyro has a 2.5 minute delay that prevents roll SAS activation until the gyro is fully erect. This occurs any time power has been interrupted to the SAS controller.

The SAS actuators remain in the neutral position until activated by the pilot with the SAS control panel. The neutral position occurs at 67.5 KIAS for the pitch actuator, zero degree bank angle for the roll actuator, and balanced flight for the yaw actuator. The aircraft boost system must be operating with pressure greater than 225 PSI for the pitch and roll SAS to function. The same pressure sensing switch is used for the BOOST caution light and for disabling the pitch and roll channels of the SAS. Yaw SAS does not require boost system operation.

The SAS is fully operational from 40 KIAS to 90 KIAS for pitch, roll, and yaw. Yaw is disabled below 35 KIAS. The pitch channel will only provide stability augmentation in one direction when outside the 35–100 KIAS operating range, while the roll channel will only provide stability augmentation in one direction when beyond 22 degrees angle of bank.

Pitch SAS

The pitch SAS responds to airspeed and pitch rate signals. The airspeed signals provide a pitch trim bias input for positive longitudinal static stability. This results in forward cyclic trim positions with increasing airspeed. Pitch rate is used to minimize pilot workload and aid the pilot in maintaining a desired pitch attitude. The pitch SAS has 15% control authority (± 0.83 inches).

Roll SAS

The roll SAS responds to roll attitude and roll rate inputs. The roll attitude provides positive spiral stability. This results in lateral cyclic positioned into the turn (holding cyclic into the turn). Roll rate is used to minimize pilot workload and aid the pilot in maintaining a desired roll attitude. The roll SAS has 12% authority (± 0.72 inches).

Yaw SAS

The yaw SAS responds to yaw rate and lateral acceleration. Yaw rate aids the pilot in maintaining a desired yaw attitude and the lateral (pendulum) accelerometer senses sideslip and will aid the pilot in maintaining “ball-centered” flight during operations from 35–100 KIAS. The amount of input is decreased with increasing airspeed as the rudder becomes more effective. The yaw SAS has 11% authority (± 0.33 inches).

SAS Caution Lights

Each SAS channel (pitch, roll, yaw) has an independent caution light on the caution panel associated with the SAS. The caution lights indicate which channel(s) are inoperative.

SAS Actuators

Each SAS actuator has the mechanical capability of moving 0.2325 inches. The actuator motors are geared down to respond with a significantly slower mechanical response than what can be commanded electronically. This difference between the electronic signal and the mechanical response generates an error voltage feedback signal. When this error signal exceeds approximately 2 volts, it will trip the feedback error detector and shut off the actuator receiving the high voltage or hardover signal. Detection and actuator shutdown occur quickly and eliminate the need for the pilot to correct an uncommanded aircraft attitude.

SAS Disable Switch

The SAS Disable switch is located on the collective and, when activated, will disconnect power to the SAS controller. The switch incorporates a lighted face to provide positive indication of switch engagement. Once activated, power is removed from the SAS controller, the actuators are fixed in place, and the pitch, roll, and yaw caution lights on the caution panel are illuminated. A second activation of the SAS Disable switch will restore power to the SAS controller, extinguish the light on the switch, and after a short (~6 second) power-on BIT, restore normal operation to the pitch and yaw channels. The roll channel requires a 2.5 minute delay to ensure that the roll rate gyro is fully erect and functional. Maintain a level attitude and unaccelerated flight during roll rate gyro erection for optimum gyro accuracy. The roll channel will re-engage automatically after the 2.5 minute warm-up.

Forestry Beacon

An additional strobe light may be mounted on the shear tie adjacent to the existing anti-collision light. This strobe light is equipped with a red/clear lens to meet requirements of the U. S. Forest Service for fire fighting aircraft. This light can be controlled independently of the anti-collision light system through use of the forestry beacon switch mounted on the cockpit instrument panel. All three strobe assemblies receive power from the same circuit breaker marked "STROBE LT". This light is only to be used when the aircraft is actively engaged in fire fighting operations.

Section 7 **Weight and Balance**

Contents

| | |
|-------------------------------------|-----|
| General | 7-2 |
| Helicopter weighing procedure | 7-2 |
| Weight and balance record | 7-2 |
| Loading instructions | 7-6 |

General

The helicopter must be flown within the weight and balance limits specified in Section 2. Loadings outside these limits could result in insufficient cyclic control to safely operate the helicopter.

Helicopter Weighing Procedure

The helicopter does not have a longitudinal leveling plate. A standard level or protractor, placed on the cockpit door sill, is used to position the aircraft in a level condition. The aircraft empty weight includes engine oil, transmission oil, and unusable fuel.

CAUTION

Fuel loading can result in exceeding MGW

1. Fold rotor blades. (Ref. KMM 10-00)
2. Ensure transmission, engine, and rotor brake systems are properly serviced. (Ref. KMM 12-10)
3. Defuel fuel tank. (Ref. KMM 12-10)
4. Position aircraft for weighing:

Weighing with landing gear on scales (8,000 lb. min. capacity); wheel locations follow:

- | | | |
|----------------------|----------|--------|
| a. Forward LG: | FCS STA. | 30.23 |
| b. RH Main LG: | FCS STA. | 196.13 |
| c. LH Main LG: | FCS STA. | 196.13 |

Weighing with aircraft on jacks (Ref. KMM 07-00); jack locations follow:

- | | | |
|------------------------|----------|--------|
| a. Forward jack: | FCS STA. | 46.15 |
| b. RH Main jack: | FCS STA. | 188.53 |
| c. LH Main jack: | FCS STA. | 188.53 |
5. Position protractor or level on cockpit door sill.
 6. Level aircraft.
 7. Obtain readings from all three scales; proceed with standard weight and balance calculations. Refer to flight manual for aircraft weight and balance form.
 8. Remove aircraft from scales or jacks.

Weight And Balance Record

The following forms (Form 1A and 1B) should be used to maintain a continuous record of the helicopter's weight and balance. Each time an item of equipment is installed or removed, an entry must be made and the new moment determined. The CG locations for various items of equipment are given in the Table 7-1 weight and balance equipment list.

WEIGHT AND BALANCE RECORD
Continuous History of Changes in Structure or Equipment Affecting Weight and Balance

| HELICOPTER MODEL K-1200 | | SERIAL NUMBER | | PAGE NUMBER | | WEIGHT CHANGE | | RUNNING BASIC EMPTY WEIGHT | |
|-------------------------|----------|---------------|----------------------------------------|-------------|----------|---------------|----------|----------------------------|-------------|
| DATE | ITEM NO. | | DESCRIPTION OF ARTICLE OR MODIFICATION | ADDED (+) | | REMOVED (-) | | Wt. (lb) | Moment /100 |
| | In | Out | | Wt. (lb) | Arm (in) | Wt. (lb) | Arm (in) | | |
| | | | HELICOPTER EMPTY WEIGHT | | | | | | |
| | | | | | | | | | |
| | | | | | | | | | |
| | | | | | | | | | |
| | | | | | | | | | |
| | | | | | | | | | |
| | | | | | | | | | |
| | | | | | | | | | |
| | | | | | | | | | |
| | | | | | | | | | |
| | | | | | | | | | |
| | | | | | | | | | |
| | | | | | | | | | |
| | | | | | | | | | |

Form 1A. Weight and Balance Record

Kaman K-1200
Rotorcraft Flight Manual

WEIGHT AND BALANCE RECORD
Continuous History of Changes in Structure or Equipment Affecting Weight and Balance

| HELICOPTER MODEL K-1200 | | SERIAL NUMBER | PAGE NUMBER | WEIGHT CHANGE | | | | | | RUNNING BASIC EMPTY WEIGHT | | |
|-------------------------|----------|---------------|----------------------------------------|---------------|----------|-------------|-------------|----------|-------------|----------------------------|-------------|--|
| DATE | ITEM NO. | | DESCRIPTION OF ARTICLE OR MODIFICATION | ADDED (+) | | | REMOVED (-) | | | Wt. (lb) | Moment /100 | |
| | In | Out | | Wt. (lb) | Arm (in) | Moment /100 | Wt. (lb) | Arm (in) | Moment /100 | | | |
| | | | | | | | | | | | | |
| | | | | | | | | | | | | |
| | | | | | | | | | | | | |
| | | | | | | | | | | | | |
| | | | | | | | | | | | | |
| | | | | | | | | | | | | |
| | | | | | | | | | | | | |
| | | | | | | | | | | | | |
| | | | | | | | | | | | | |
| | | | | | | | | | | | | |
| | | | | | | | | | | | | |
| | | | | | | | | | | | | |
| | | | | | | | | | | | | |
| | | | | | | | | | | | | |
| | | | | | | | | | | | | |

Form 1B. Weight and Balance Record

Table 7-1. Weight and Balance Equipment List

| Item | Station (Inches) | Weight (Lbs) |
|----------------------------------------------------------------------------------------------------------------------------------------------------------------------------------------------------------------------------------------------------------------------------------------------------------------------|---------------------|--------------------------------------|
| NOTE | | |
| An equipment list giving the weight and location of removable items of equipment is provided with each helicopter. This equipment list must be kept with the weight and balance records for the aircraft. For purposes of calculating weight and balance changes, the following additional information is presented: | | |
| Nose wheel skid | 34.5 | 12.0 |
| Main wheel skid | 196.14 | 12.0 (each) |
| Cabin door | 111.07 | 19.15 (each) |
| Cargo door | 169.17 | 10.8 (each) |
| Cargo hook | 167.41 | 13.0 |
| Fire extinguisher | 119.35 | 8.0 |
| First aid kit | 127.4 | 2.0 |
| Mirror installation | 60.0 | 5.0 (each with 12 inch mirror) |
| Map and data case | 78.0 | 1.25 (empty) |
| OAT indicator | 90.0 | 0.1 |
| Clock | 80.0 | 0.1 |
| Vertical speed indicator | 80.0 | 1.0 |
| Turn and slip indicator | 80.0 | 1.0 |
| Hobbs meter | 80.0 | 0.1 |
| External instrument panel | 102.0 | 4.0 |
| Allied Signal KX-165 VHF NAV/COMM | 80.0 | 5.0 |
| Allied Signal KLN 90 GPS system | 80.6 | 6.0 |
| Technisonic TFM 138B FM radio | 80.0 | 3.5 |
| NAT AA22-110 Siren/loudhailer system | 100.0 | 15.0 |

Table 7-1. Weight and Balance Equipment List (Continued)

| Item | Station (Inches) | Weight (Lbs) |
|------------------------------------------------------|------------------|---------------|
| Allied Signal KT-70/KT-71 mode transponder | 100.0 | 4.25 |
| NAT AA12-001 audio distribution panel | 100.0 | 1.0 |
| Allied Signal K1525A horizontal situation indicator | 80.0 | 3.5 |
| Landing light | 20.0 | 5.0 |
| Emergency locator transmitter | 125.0 | 1.9 |
| Flight controls protective panel (vertical controls) | 142.0 | 1.0 |
| Flight controls protective panel (azimuth) | 170.0 | 6.5 |
| Torso support | 115.0 | 5.2 |
| Headliner (If installed) | 120.0 | 8.0 |
| PCDS (LH or RH if installed) | 167.4 | 25.0 per seat |
| Boost installation (If installed) | 152.10 | 124.2 |
| SAS installation (If installed) | 147.04 | 75.06 |
| IFR installation (If installed) | 97.37 | 44.58 |

Loading instructions

General

Figures 7-1 through 7-5 indicate pertinent weight and balance data as follows:

- Figure 7-1 Stations and waterlines
- Figure 7-2 Center of gravity limits
- Figure 7-3 Internal cargo loading diagram
- Figure 7-4 Fuel load center of gravity table
- Figure 7-5 Fuel load center of gravity chart

Sample Loading Calculations

The following sample loading calculation may be used to determine the CG of the helicopter.

No Internal Cargo

| | Weight (lbs) | Arm (in) | Moment (in-lbs) |
|--------------------------------|-----------------|---------------|--------------------|
| A/C empty weight | +5,150.0 | 172.60 | +888,890 |
| Pilot | +200.0 | 108.00 | +21,600 |
| Start fuel | <u>+1,150.0</u> | <u>160.87</u> | <u>+185,000</u> |
| Start GW | 6,500.0 | 168.54 | 1,095,490 |
| Max external weight capability | 5,500.0 | | |

Internal Cargo

| | Weight (lbs) | Arm (in) | Moment (in-lbs) |
|--------------------------------|-----------------|---------------|--------------------|
| A/C Empty weight | +5,150.0 | 172.60 | +888,890 |
| Pilot | +200.0 | 108.00 | +21,600 |
| Start fuel | +900.0 | 160.03 | +144,027 |
| Internal cargo | <u>+250.0</u> | <u>175.00</u> | <u>+43,750</u> |
| Start GW | 6,500.0 | 168.96 | 1,098,267 |
| Max external weight capability | 5,500.0 | | |

Kaman K-1200
Rotorcraft Flight Manual

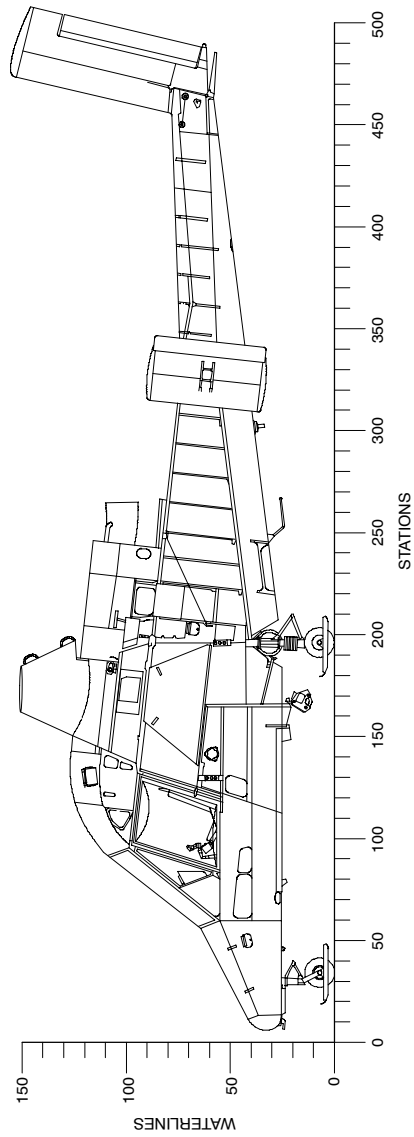

Figure 7-1. Stations and Waterlines

Kaman K-1200
Rotorcraft Flight Manual

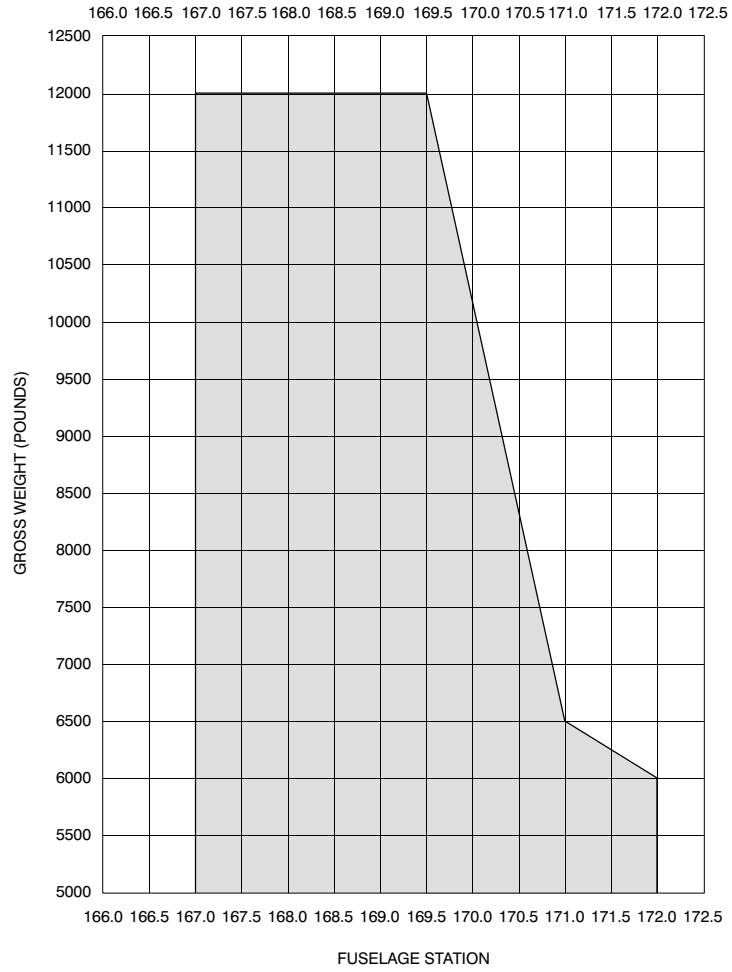

Figure 7-2. CG Limits

Kaman K-1200
Rotorcraft Flight Manual

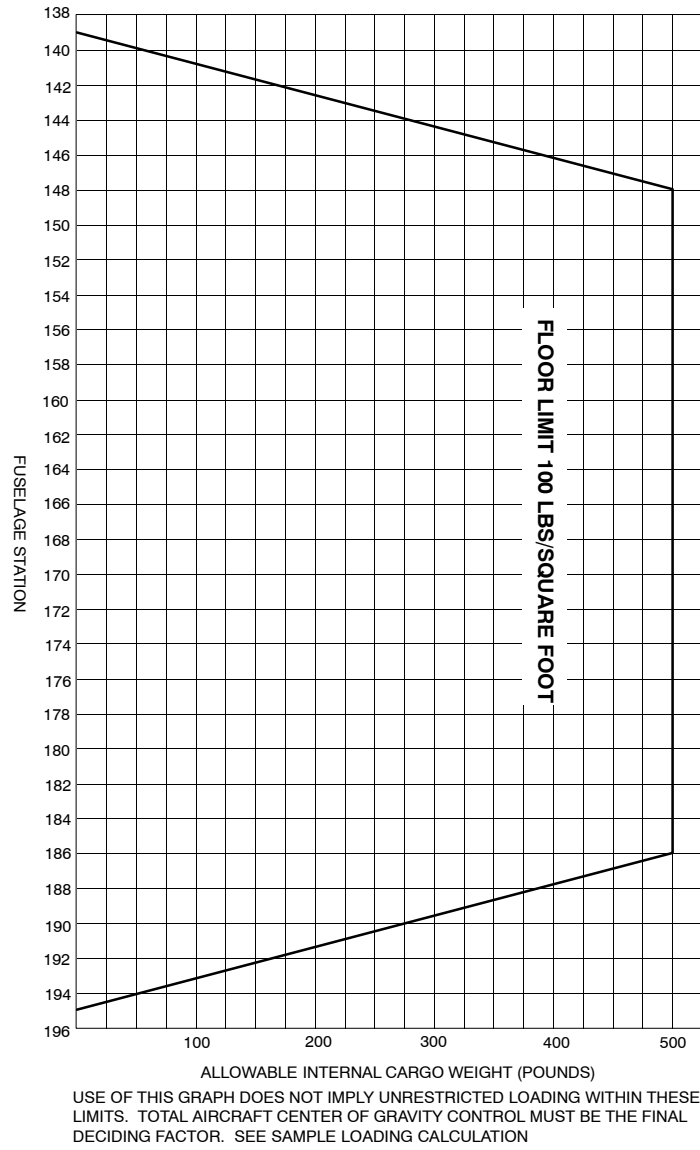

Figure 7-3. Internal Cargo Loading Diagram

Kaman K-1200
Rotorcraft Flight Manual

| Pounds | CG | Moment | Pounds | CG | Moment |
|--------|--------|--------|--------|--------|--------|
| 50.0 | 153.43 | 7671 | 675.0 | 159.14 | 107419 |
| 100.0 | 155.20 | 15520 | 700.0 | 159.25 | 111472 |
| 125.0 | 155.63 | 19454 | 725.0 | 159.35 | 115529 |
| 150.0 | 155.96 | 23394 | 750.0 | 159.45 | 119589 |
| 175.0 | 156.23 | 27341 | 775.0 | 159.55 | 123653 |
| 200.0 | 156.47 | 31293 | 800.0 | 159.65 | 127721 |
| 225.0 | 156.68 | 35252 | 825.0 | 159.75 | 131793 |
| 250.0 | 156.87 | 39217 | 850.0 | 159.84 | 135867 |
| 275.0 | 157.05 | 43188 | 875.0 | 159.94 | 139946 |
| 300.0 | 157.21 | 47164 | 900.0 | 160.03 | 144027 |
| 325.0 | 157.37 | 51146 | 925.0 | 160.12 | 148112 |
| 350.0 | 157.52 | 55134 | 950.0 | 160.21 | 152200 |
| 375.0 | 157.67 | 59127 | 975.0 | 160.30 | 156290 |
| 400.0 | 157.81 | 63125 | 1000.0 | 160.38 | 160384 |
| 425.0 | 157.95 | 67128 | 1050.0 | 160.55 | 168580 |
| 450.0 | 158.08 | 71136 | 1100.0 | 160.72 | 176787 |
| 475.0 | 158.21 | 75149 | 1150.0 | 160.87 | 185004 |
| 500.0 | 158.33 | 79167 | 1200.0 | 161.03 | 193231 |
| 525.0 | 158.46 | 83190 | 1250.0 | 161.17 | 201467 |
| 550.0 | 158.58 | 87217 | 1300.0 | 161.32 | 209712 |
| 575.0 | 158.69 | 91249 | 1350.0 | 161.46 | 217965 |
| 600.0 | 158.81 | 95285 | 1400.0 | 161.59 | 226226 |
| 625.0 | 158.92 | 99326 | 1450.0 | 161.72 | 234493 |
| 650.0 | 159.03 | 103370 | 1495.0 | 161.83 | 241940 |

Figure 7-4. Fuel Load Center of Gravity Table

Kaman K-1200
Rotorcraft Flight Manual

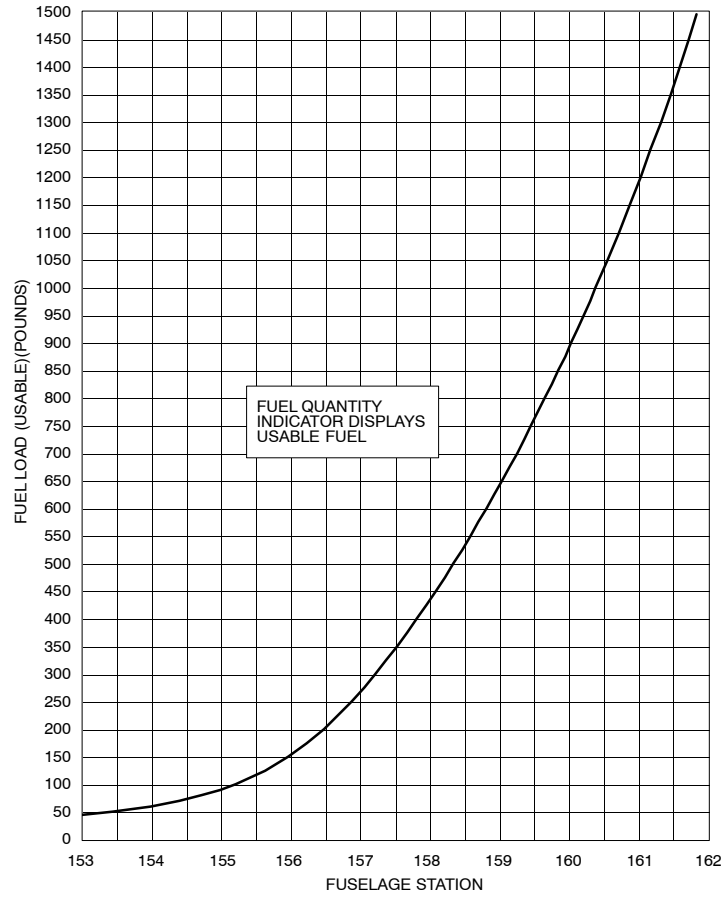

Figure 7-5. Fuel Load Center of Gravity Chart

Section 8 Systems

Contents

| | |
|------------------------------------------|------|
| Fuselage | 8-2 |
| Powerplant | 8-3 |
| Powerplant controls and indicators | 8-4 |
| Engine start and ignition | 8-4 |
| Engine fuel pump | 8-5 |
| Engine anti-Ice | 8-5 |
| Engine air | 8-5 |
| Fuel system | 8-6 |
| Chip detection system | 8-6 |
| Transmission | 8-7 |
| Rotor brake | 8-8 |
| Rotor system | 8-8 |
| Hub assembly | 8-10 |
| Hub-to-blade control rod assembly | 8-10 |
| Droop stop assembly | 8-11 |
| Damper assembly | 8-11 |
| Blade assembly | 8-11 |
| Servo-flap assembly | 8-12 |
| Inflight tracking actuator | 8-12 |
| Rotor blade adjustments | 8-12 |
| Flight controls | 8-12 |
| Cyclic control | 8-12 |
| Collective control | 8-13 |
| Directional control | 8-14 |
| Rudder trim | 8-15 |
| Landing gear | 8-15 |
| Electrical system | 8-16 |
| Lighting system | 8-17 |
| Heating/ventilation system | 8-18 |
| Instruments | 8-19 |
| Recording instruments | 8-20 |
| General | 8-20 |
| H1973-1 Load indicator/monitor | 8-20 |
| H1973-2 Load indicator/monitor | 8-21 |

Contents (Continued)

| | |
|-----------------------------------------------------------|------|
| H1943-1 Torque indicator/monitor | 8-22 |
| H1943-7 Torque indicator/monitor | 8-23 |
| H1901-1 N_G indicator/monitor | 8-24 |
| H1900K-2 EGT indicator/monitor | 8-24 |
| H1900K-22 EGT indicator/monitor | 8-25 |
| Pitot-static system | 8-26 |
| Pilot seat | 8-26 |
| External load system | 8-27 |
| Dual cargo hook release for long-line | 8-28 |
| C60 Multi-Hook Carousel | 8-28 |
| AIM 510 attitude gyro | 8-29 |
| AI 330 attitude indicator | 8-29 |
| AI 804 standby attitude indicator | 8-30 |
| KCS 55A compass system | 8-30 |
| KR22 marker beacon | 8-31 |
| KX 165 VHF navigation/communication transceiver | 8-31 |
| Hobbs 85000 hour meter | 8-31 |
| M800 digital chronometer | 8-31 |
| LC-6 clock | 8-31 |
| KT 70 transponder | 8-31 |
| KLN 90 GPS | 8-32 |
| AA22-110 PA system (siren/loudhailer) | 8-32 |
| AA12-001 audio panel | 8-32 |
| TFM138B FM transceiver | 8-33 |
| Aural Warning System | 8-33 |

Fuselage

The fuselage is a semi-monocoque structure constructed primarily of aluminum alloy. The single-seat cockpit includes an energy absorbing seat designed to withstand high "G" loads. There are two doors, one on either side of the cockpit, that can be removed. There is an equipment bay in the nose of the aircraft which contains the battery and relay boxes and provides access to the nose wheel strut.

Just behind each door is a large, trapezoidal-shaped access panel. Lowering either panel gives access to an equipment bay and portions of the transmission, flight control system, and the fuel bladder. An integral work platform is mounted to both sides of the fuselage, behind the access panels. The platform can be folded when not in use.

The empennage is equipped with stabilizers and a rudder. The stabilizers are mounted on each side of the tail and consist of a horizontal surface with vertical stabilizers mounted on the outboard edge of each. The rudder is mounted to the trailing edge of the vertical fin.

Powerplant

The single Honeywell T5317A-1 turboshaft engine is located above the fuselage and behind the two rotor pylons. The engine has an external, annular, atomizing-type combustor, a two-stage gas producer turbine driving a combination axial-centrifugal compressor (N_G system), and a two-stage free power turbine (N_2 system). The integral engine systems include lubrication, internal cooling, pressurization and anti-icing, fuel and fuel control, electrical, interstage air-bleed and variable inlet guide vanes.

The N_G system consists of two gas producer nozzles, two turbine wheels, an axial-centrifugal compressor, and the combustor. As the compressed fuel-air mixture burns in the combustor, the nozzles increase the velocity of the gases and direct the gas flow onto the turbine wheels at a preset angle. As the hot gases impinge onto the curved airfoils of the turbine wheels, the velocity of the gases at the exit of the blades is increased still further. Power is extracted to drive the compressor, the N_2 system, and accessories.

The N_2 system consists of two power-turbine nozzles, two power-turbine wheels, power shaft, and reduction gearing. The function of the two turbine nozzles and wheels is the same as the gas producer nozzles and wheels. The N_2 system is mechanically independent of the N_G system. This arrangement allows a constant N_2 speed to be maintained with varying N_G speed. Thermal energy extracted by the power turbine is delivered through a coaxial power shaft to the reduction gear. The reduction gear is a two step helical gear, with coaxial input and output shafts, that delivers power to the transmission assembly.

Engine lubricating oil is supplied from the aircraft mounted oil tank. The tank is located above the cockpit ceiling on the right side of the aircraft. It has a usable capacity of 3.21 gallons with a 1.18 gallon expansion space. It also has an oil level sight gauge on the outboard side that can be viewed from the ground. A scavenge oil filter is located prior to the engine oil cooler. This 3 micron filter removes particles in the oil prior to the oil returning through the cooler and into the oil tank. An engine oil cooler is mounted above the cockpit ceiling between the engine and transmission oil reservoirs. Cooling air is provided by an oil cooler fan which is driven by the transmission. The fan furnishes cooling air for both the engine and transmission oil coolers.

Powerplant Controls and Indicators

The twist-grip throttle is located on the collective pitch lever. Twisting the throttle to the left increases engine power and twisting to the right decreases engine power. There are four power setting detents: OFF, GND IDLE, FLT IDLE, and FLY. Throttle movement is forward and left from OFF to GND IDLE, forward and left again for FLT IDLE, and more forward and left to the FLY position.

The throttle may be moved to the OFF position by pulling the throttle aft and rotating it right past three detents. This shuts the engine down by closing the fuel control stopcock. GND IDLE is used for starting and shutdown. GND IDLE controls engine power up to 48–52% N_G and approximately 35% N_R . When the rotor brake is engaged, a locking plunger prevents the throttle from being advanced beyond GND IDLE. FLT IDLE controls power to 68–72% N_G and approximately 60% N_R . FLY controls engine power from 85±1% N_R up to 104±1% N_R and is the power setting used for normal flight operations.

Rotor RPM is controlled by the pilot with an engine RPM switch on the collective switch box with the throttle in the FLY position. The engine governor (GOV) switch is located on the collective switch box. It is a covered switch labeled NORM (normal) and EMER (emergency). The switch is in the normal position when covered. Emergency governing is selected by lifting the cover and moving the switch to the EMER position. The cover must remain up while emergency governing of the engine is desired.

The START trigger is located on the bottom of the collective at the forward end of the throttle. It is used for engine motoring and engine starting.

Engine Start and Ignition

The FUEL/OIL switch, located on the LH switch panel, opens the fuel and oil valves, turns the boost pumps on, and completes the electrical starting circuit. Start fuel is enabled and the starting circuit is energized when the START trigger is pulled. The throttle in the GND IDLE position enables primary fuel at 8–10% N_G and secondary fuel at 32% N_G during start.

Engine start requires the following:

1. FUEL/OIL switch ON.
2. No OIL VLV or FUEL VLV caution lights.
3. Minimum of one fuel boost pump operating.
4. Throttle in GND IDLE position.
5. START TEST switch in NORMAL position.
6. Pull and hold trigger switch until N_G reaches and exceeds 36%.
7. Release trigger switch.

Motoring the engine without fuel or ignition requires:

1. FUEL/OIL switch ON.
2. Throttle OFF.
3. START TEST switch in START TST position.
4. Pull and hold trigger switch to motor engine.

The three position toggle type start/ignition test switch is located on the switch panel assembly. The three positions are marked START TST, NORM, and IGN TST. When the test switch is placed in the START TST position and the trigger switch is pulled, the starter/generator is allowed to spin with the ignition unit disabled. When the test switch is placed in the IGN TST position and the trigger switch is pulled, the ignition unit is energized, allowing it to fire, while the starter/generator is disabled.

Engine Fuel Pump

The engine is equipped with a dual element positive displacement gear-type fuel pump. Each element delivers fuel continuously and is capable of supplying sufficient fuel for engine operations. Aircraft with SB 075 incorporated, are equipped with an ENG FUEL PUMP caution light which will illuminate upon failure of either element of the engine fuel pump.

Engine Anti-Ice

The engine anti-ice system provides a means of preventing the formation of ice on the inlet of the engine. The engine anti-ice system consists of an anti-ice bleed air valve and the ANTI-ICE control switch, located on the RH switch panel.

The engine anti-ice lighting system is used to monitor and provide visual indications of the engine anti-ice condition and operation. The engine anti-ice system consists of an ENG ICE caution light controlled by ambient temperature and an ENG DEICE advisory light. The ENG ICE caution light illuminates at +7° C temperature. Activating engine anti-ice turns off the ENG ICE caution light and turns on the ENG DEICE advisory light.

Engine Air

An inlet particle separator is located aft of the transmission and surrounds the inlet of the engine. Engine intake air is drawn through particle separator swirl vanes which filter foreign matter and direct air to engine inlet. When the PART SEP switch is in the ON position, the contaminants, dust, and other foreign matter are ejected out through ejection ports located on both sides of the separator.

Fuel System

The fuel system consists of the fuel tank, boost pumps, filter, shutoff valve, check valves, vent valves, and system controls and indicators. Fuel is delivered by two boost pumps, through the fuel filter and fuel shutoff valve, to the inlet port of the engine fuel control unit.

The fuel tank is located in a cavity under the cargo floor. The tank has a total capacity of 228.5 gallons to the filler neck. The tank is vented to the atmosphere through two vent valves located within the tank. The vent tubes are located at the bottom of the fuselage. An electrically operated boost pump is located at each of the two fuel sumps. Check valves in each of the interconnecting boost pump lines permit fuel discharged by the boost pumps to flow only to the filter, preventing flow back into the sumps. The fuel tank filler cap is located on the left side of the fuselage.

The forward boost pump pressure switch is located in the forward boost pump discharge line. The switch will actuate when the forward pump pressure output is less than 4 psi, and illuminate the FWD PUMP caution light, before SB 075 (FUEL BOOST PUMP caution light, after SB 075). The aft boost pump pressure switch is located in the aft boost pump discharge line. The switch will actuate when the aft pump pressure output is less than 4 psi, and illuminate the AFT PUMP caution light, before SB 075 (FUEL BOOST PUMP caution light, after SB 075).

The independent fuel low caution light system indicates that a low fuel condition exists. A LOW FUEL caution light, located on the caution/advisory panel, indicates that approximately 10 minutes of fuel remain. The light is amber and is actuated by a fuel-level sensing unit mounted to the gauge tank unit, at a fixed height above the bottom of the fuel tank. Whenever fuel in the tank falls below the level of the sensing unit (100±15 pounds), the LOW FUEL caution light will glow on the caution/advisory panel.

A fuel quantity gauge, fuel pressure gauge, and FUEL/OIL switch are located on the instrument panel. The FUEL/OIL switch controls fuel flow from the fuel tank to the engine.

Chip Detection System

Chip detection systems are installed in the engine and transmission lubricating systems to provide early detection and a visual warning of possible component deterioration/failure.

The engine oil system employs a quick-disconnect type chip detector at the base of the engine oil tank and a threaded type chip detector on the lower part of the engine. Detection of metal particles by either of these detectors results in illumination of the MAST CAUT and ENG CHIP warning lights.

The transmission oil system employs a quick-disconnect type chip detector at the base of the transmission oil tank and two quick-disconnect type chip detectors located on the left and right sumps of the transmission. Detection of metal particles by any of the three detectors will result in illumination of the MAST CAUT and XMSN CHIP warning lights.

A chip burn-off system is installed to remove fuzz or small ferrous particles caused by normal wear that have caused illumination of the chip warning lights. A momentary-type switch labelled FUZZ BURN is located on the lower left part of the main instrument panel to activate this system. When the fuzz-burn switch is depressed a short-duration pulse of current is provided to all chip detectors. This will normally cause the MAST CAUT and appropriate CHIP WARNING lights to extinguish if the fault was only fuzz or small ferrous particles caused by normal wear.

Transmission

The transmission provides controlled application of engine power to the rotors. The main components are an engine-to-transmission KAflex drive shaft coupling, the transmission assembly (with an integral freewheeling clutch mechanism), and the rotor brake. The transmission assembly synchronizes the rotors and drives them at approximately $\frac{1}{24}$ of engine output shaft speed.

The transmission assembly drives the rotor tachometer and has a power take-off pad for an added accessory. Temperature and pressure gauges are provided for monitoring of the transmission lubricating oil system.

Two oil pressure switches are located in the cargo compartment overhead, aft of the transmission. The transmission oil pressure switch, located on the LH side of the fitting, activates the XMSN PRESS advisory panel light when the oil pressure falls below 25 psi. The airborne pressure switch, located on the RH side of the fitting, is used in conjunction with the collective switch (before SB 042R1) and the Hobbs hour meter to record helicopter operating time. A weight-on-wheels switch is installed (after SB 042R1) to record helicopter operating time.

The transmission oil system consists of an external tank, a pump and a cooler. The oil tank is located above the cockpit ceiling on the left side of the aircraft. It also has an oil level sight gauge on the outboard side that can be viewed from the ground. The oil tank has a usable capacity of 3.21 gallons, with a 1.18 gallon expansion space. The oil pump is mounted on and driven by the transmission and contains gear-type pumping elements. One pump element delivers oil under pressure to the transmission. Another element delivers oil under pressure to the collective limiter. Two additional elements return transmission scavenge oil to the oil tank through the oil cooler.

A transmission oil filter is located between the oil tank and transmission. This 3 micron filter removes particles in the oil prior to the oil being delivered to the transmission. Additionally, a transmission oil cooler scavenge filter is located prior to the oil cooler. This 3 micron filter removes particles in the oil prior to the oil returning through the cooler and into the oil tank. The transmission oil cooler and oil cooler fan are mounted above the cockpit ceiling between the transmission and engine oil tanks. Operation is completely automatic and requires no controls. Cooling air is provided by an oil cooler fan which is driven by the transmission. The fan furnishes cooling air for both the transmission and engine oil coolers. A combined transmission oil pressure/oil temperature gauge is located on the instrument panel.

Rotor Brake

A hydraulic rotor brake is installed to prevent the rotors from freewheeling during engine start and after engine shutdown. The brake is a disc-type friction unit mounted on the transmission housing. Application of the brake is controlled by a rotor brake lever, located above the pilot seat (Figure 8-1). The lever forces fluid, under pressure, from a master cylinder, actuating the friction brake. At the same time, hydraulic pressure is directed to a throttle-locking plunger, which prevents the throttle from being advanced beyond GND IDLE when the rotor brake is engaged.

The rotor brake has its own fluid supply, with the reservoir mounted on the brake at the highest point in the system. The rotor brake lever is on the left side of the cockpit ceiling, and is connected directly to the master cylinder. By pulling down and back on the lever, the brake may be applied with a controlled amount of pressure. Pulling the lever fully aft locks the brake on. The brake is released by pulling the lever down and forward.

The rotor brake master cylinder is equipped with a spring-loaded locking pin that can be used to lock the brake in the ON position.

Rotor System

The K-1200 has dual counter-rotating rotors which are synchronized by gearing within the single main transmission. Rotor torque is resolved in the gearbox.

The rotors, each consisting of a hub and two rotor blades, are driven by hollow rotor shafts extending down through the pylons to the transmission. The right-hand rotor shaft, color coded with a red square, rotates in the clockwise direction as viewed from the top and the left-hand rotor shaft, color coded with an orange circle, rotates in a counterclockwise direction as viewed from the top. Each rotor hub is attached to its rotor shaft by a tapered teeter pin. Droop stops prevent excessive teetering of the blades during rotor starts and stops.

Kaman K-1200
Rotorcraft Flight Manual

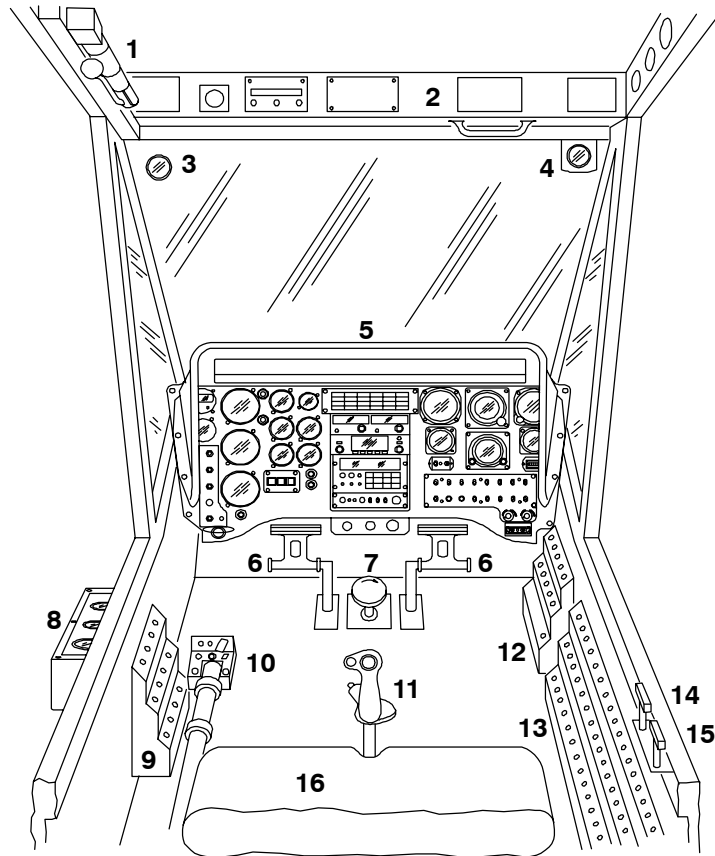

- | | |
|---------------------------------------------|-----------------------------------------------|
| 1. ROTOR BRAKE | 9. LH CIRCUIT BREAKER PANEL (IF INSTALLED) |
| 2. OVERHEAD CONSOLE | 10. COLLECTIVE LEVER |
| 3. OAT PROBE | 11. CYCLIC STICK |
| 4. STANDBY COMPASS | 12. RH FORWARD CIRCUIT BREAKER PANEL |
| 5. MAIN INSTRUMENT PANEL AND GLARESHIELD | 13. RH AFT CIRCUIT BREAKER PANEL |
| 6. RUDDER PEDAL | 14. NOSE WHEEL LOCK |
| 7. RUDDER PEDAL ADJUSTMENT KNOB | 15. PARKING BRAKE |
| 8. EXTERNAL INSTRUMENT PANEL | 16. SEAT |

Typical Installation Shown – Validate Your Aircraft

Figure 8-1. K-1200 Cockpit

A servo flap is mounted on each blade near the $\frac{3}{4}$ radius and is controlled by push/pull rods which transfer conventional cockpit flight control inputs through the azimuth assemblies to each servo-flap. The servo-flap controls the pitch of the rotor blade and acts as an aerodynamic stabilizer. Because the servo-flap uses energy drawn from the airstream to twist the blade, control forces need only be high enough to deflect the small servo-flap. The control system operating loads are relatively light, resulting from the low aerodynamic forces on the flaps compared to blade aerodynamic forces. This eliminates the requirement for hydraulic boost and artificial stability augmentation systems for operations in visual meteorological conditions.

Rotor blade pitch changes are accomplished through the servo-flaps. Aerodynamic action of the servo flap changes blade pitch by twisting the blades. Blade pitch is controlled by the collective stick, the cyclic stick, and the directional pedals, all of which are connected to the servo flaps by direct mechanical linkage.

Hub Assembly

The hub assembly provides a means for mounting each rotor blade.

Each hub assembly consists of an upper half and a lower half. The upper half is secured to the rotor shaft with a tapered teeter pin, and the lower half is secured to the upper half with nuts and bolts.

The upper and lower halves of each hub assembly are matched and serialized during manufacture and must be installed or replaced as a set. Painted symbols on the hub and rotor shaft are used to indicate left and right components thus assuring proper installation when matched. The hub identified with a red square must be installed on the RH rotor shaft. The hub identified with an orange circle must be installed on the LH rotor shaft.

The hub ears are identified with a red and white stripe. The red (tracking) blade is attached to the red striped hub ear and the white (non-tracking) blade is attached to the white striped hub ear.

There are two L-crank assemblies positioned between the upper and lower hub halves. The L-cranks transmit vertical movement of the azimuth bar-to-hub control rods outward to the hub-to-blade control rods.

Hub-to-Blade Control Rod Assembly

The hub-to-blade control rod assembly transmits control movement from the hub L-crank to the blade controls.

Droop Stop Assembly

The droop stop assemblies, two per hub, prevent excessive teetering of the hubs and blades at low rotor RPM. At rotor speeds of approximately 50% the droop stops automatically move out by centrifugal force acting on their flyweights. The droop stops move in at approximately 40% rotor speed.

Each one is spring loaded so that, at low RPM, a bumper is positioned between the hub assembly and the rotor shaft. Increasing rotor RPM causes the droop stop flyweight to pivot outward against spring tension.

Damper Assembly

Mechanical friction dampers are installed between the two blades of each rotor to prevent excessive lead-lag oscillations.

The damper consists of two major components, an aluminum tube assembly and a damper housing. The tube assembly is coated with a hard anodic coating and moves through the damper housing. Each end of the damper incorporates a large uniball rod end.

The damper housing has two split halves that are lined with a Karon "V" material. Adjustments are made to the damper friction setting by means of one spring-loaded bolt. When the bolt is tightened, this compresses a series of Belleville washers that increase the friction between the Karon "V" material and the damper tube.

Blade Assembly

The blades are of composite construction. Each blade includes a servo flap mounted at the trailing edge and the rods, bell cranks, and hardware necessary for control of the servo flap. The rotor blade is attached to the hub by a tapered lag pin.

The rotor blade consists of a laminated sitka spruce main spar and a honeycomb core afterbody, wrapped in a composite skin. The main spar block forms the basic structure from the root end to the tip. A two piece steel blade grip assembly secures the blade root and provides a means for mounting the blade to the rotor hub assembly.

Blades are manufactured, matched and balanced in pairs. Each blade pair is identified as either left-hand or right-hand by stencils and serial numbers. The letter "L" or the letter "R" is stenciled on the upper surface of each blade grip. This indicates which rotor hub (LH or RH) the set is to be installed on. Left-hand "L" blade sets have an odd serial number, while the right-hand "R" blade sets have an even serial number. Each blade set consists of a red-tipped (tracking) and a white-tipped (non-tracking) blade.

Servo-Flap Assembly

The servo-flap responds to inputs made by the flight control system and causes aerodynamic reaction to the main rotor blade. Because of its small surface area, the forces required to move the flap are lower than those needed to move the entire blade.

The blade flap assembly is constructed of composite materials with aluminum alloy inboard and outboard fittings. A Karon maintenance-free spherical bearing is located in the flap horn portion of the inboard fitting for the flap control rod assembly. The outboard fitting is made of aluminum alloy and contains a Karon maintenance-free bearing. The flap leading edge is protected by a stainless steel guard.

Inflight Tracking Actuator

The inflight tracking actuator is an electromechanical linear actuator used to change the pitch of the servo flaps. There is one for each rotor.

Rotor Blade Adjustments

Adjustment of the blade flap angle is made to track the blades or match one rotor to the other. There are two adjustment points: the flap control rod and the tracking turnbuckle. Coarse blade track adjustments of more than two inches, or for mismatched rotors (pedals split ≥ 1 inch), are made at the flap control rod in half-turn increments. For small track adjustments of less than two inches, or mismatched rotors (less than one inch of pedal split), the tracking turnbuckle(s) are used. Arrows on the turnbuckle indicate the direction of movement for adjusting the tip path.

Flight Controls

Cyclic Control

The cyclic control system provides pitch and roll control of the helicopter (Figure 8-1). Fore and aft movement of the cyclic stick causes the aircraft to pitch by tilting both rotor discs forward or aft simultaneously. Lateral movement of the cyclic stick causes the aircraft to roll by tilting the corresponding rotor disc either right (right roll) or left (left roll).

Lateral and longitudinal spring struts are incorporated to provide positive stick force gradients in proportion to stick displacement.

Lateral and longitudinal cyclic forces can be trimmed to zero by actuation of the cyclic trim actuators. Cyclic trim is controlled by a four way electrical beeper trim switch typically located on the top of the cyclic control stick grip. Additionally, a trim release button is incorporated on the cyclic grip which also allows the pilot to set a new cyclic position. To set a new trim position it is necessary to press this trim button and release. Constantly holding the button in will result in the cyclic stick driving aft.

The azimuth assembly joins the non-rotating flight control system to the rotating rotor controls. The azimuth assembly contains two gimbal-mounted cyclic control rings (one for each rotor) that can pivot in any angular plane required by cyclic, pedal, and/or collective control input combinations. Two azimuth bar-to-hub rods transmit control movement from the azimuth to the hub L-cranks and on to the servo flaps.

Three viscous dampers are attached to the control system near the azimuth assembly to reduce vibratory feedback loads in the control system.

Aircraft fitted with the cyclic boost system have three actuators that reduce the control forces on the cyclic and eliminate all secondary forces and vibrations to the cyclic control. Viscous dampers may be removed with boost installed.

Aircraft with SAS installed incorporate an electromechanical actuator in both longitudinal and lateral cyclic controls to enhance static and dynamic stability. The stability augmentation is fully capable from 40 KIAS to 90 KIAS for pitch, roll, and yaw. **System capability is reduced outside the 40-90 KIAS range.** The pitch channel has reduced capability providing stability augmentation in one direction when below 35 KIAS or greater than 100 KIAS. The roll channel will only provide stability augmentation in one direction when beyond 22 degrees angle of bank in either direction. The yaw channel is disabled below 35 KIAS.

The cyclic incorporates a friction system which is adjusted on the lower end of the cyclic. Clockwise movement of the adjustment increases friction. The cyclic grip has an ICS/TRANSMIT trigger switch.

Collective Control

Raising the collective stick raises the servo-flap trailing edge on all four blades equally which increases the pitch of the rotor blades. Lowering the collective causes the reverse to occur.

The collective control system consists of a collective stick, counterweight assembly, limiter, and push-pull control rods connected to the rotors through

two azimuth assemblies. The collective control system also controls the horizontal stabilizer.

The collective stick incorporates the engine throttle control, collective friction adjustment mechanism, and a switch box assembly (Figure 8-1).

The collective counterweight assembly, located under the cockpit floor, is installed to balance collective stick weight. The collective friction adjustment

mechanism is incorporated to provide an adjustable mechanical friction to adjust collective control feel at the pilot's discretion.

The collective system incorporates a spring cartridge to balance collective control forces resulting from centrifugal force acting upon the rotating portion of the servo flap actuating control rods. Additionally, this spring cartridge incorporates hydraulic features to provide for smooth collective operation at all operating rotor speeds and collective positions and limits the rate of collective actuation. It is attached to, and controlled by, the collective torque tube assembly. This component is referred to as the collective limiter. The K-1200 is capable of being flown and landed with the collective limiter inoperative.

A variable pitch horizontal stabilizer is located on the tail boom to minimize pitch attitude changes with power changes. A vertical fin is mounted on each end of the horizontal stabilizer. Stabilizer positioning is mechanically controlled by, and directly proportional to, the collective stick position.

Directional Control

The K-1200 directional control system provides conventional directional control for the helicopter. Pedal inputs create a change in blade pitch in both rotors and cause a deflection of the rudder located on the aft vertical stabilizer. Pushing right pedal turns the helicopter to the right and pushing left pedal turns the helicopter to the left.

Two adjustable rudder pedals are located in the cockpit and are mounted on the forward face of the module assembly (Figure 8-1). The entire pedal assembly can be moved closer or farther away from the pilot by means of a pedal adjustment knob (Figure 8-1). When the pedals are adjusted full aft it is possible for a pedal split to exist.

Primary directional control is achieved by differential collective (increasing collective pitch of one rotor while decreasing collective pitch on the other). This develops a torque differential, causing the helicopter to turn in response to pedal inputs. In addition, differential cyclic is introduced to supplement directional control. Differential cyclic is tilting one rotor disc forward while tilting the other rotor disc aft.

The collective position controls the amount of differential cyclic and differential collective utilized with pedal inputs. At "hover power" collective positions and higher (unloaded aircraft) pedal inputs generate maximum differential collective. Below this collective position, differential cyclic is increased and differential collective is decreased to a point at which no differential collective and large differential cyclic are present for pedal inputs. Below this collective position the differential collective inputs are reversed and increased (to insure proper directional response in low power descents and autorotations) and differential cyclic is reduced back to a lower value.

Directional control is further augmented by a rudder attached to the trailing edge of the vertical stabilizer. Rudder positioning is mechanically controlled by, and directly proportional to, the pilot's pedal position.

Aircraft with SAS installed incorporate an electromechanical rudder actuator to enhance directional stability above 35 KIAS.

Rudder Trim

A rudder trim knob is located on the lower edge of the instrument panel next to the cabin heat/vent controls. The knob is mechanically connected to the rudder pedals. The knob is for maintenance use only.

Landing Gear

The fixed landing gear consists of three wheel and tire assemblies, individual high-energy absorbing shock struts, and wheel skids for soft terrain. The main wheels are fixed, while the nose wheel can swivel through 360 degrees.

The nose wheel is self-centering in the fully extended position, and can be locked in the forward position by operation of the nose wheel lock control. A nose wheel lock handle is located to the right of the pilot seat, just behind the parking brake handle (Figure 8-1). The lever is connected by means of a cable to a spring-loaded locking pin in the nose wheel assembly. When the lever is moved down, the spring presses the pin downward. When the nose wheel is aligned forward, the pin drops into a hole in the swivel portion of the gear, locking it in the forward position. When the lever is moved up, the pin is withdrawn and the nose wheel is free to swivel. The nose wheel should be locked for all rotor engagements, takeoffs, landings, and rotor disengagements.

The main landing gear has a wide base for aircraft stability and pilot visibility. The main wheels are equipped with disc-type hydraulic brakes that can be individually applied from toe brake pedals at the top of the directional control pedals. The brakes can be locked for parking. Each brake has an independent hydraulic system. The system consists of a master cylinder, attached to each brake pedal, and hydraulic lines leading through a parking brake valve to the brake unit on each wheel.

A parking brake handle is located to the right of the pilot seat (Figure 8-1), forward of the nose wheel lock handle. It is connected by mechanical linkage to valves in the wheel brake hydraulic lines. To engage the parking brake, apply and hold pressure on the toe brake pedals, pull up on the parking brake handle, and release the pressure on the pedals. To release the parking brake, apply pressure on the toe brake pedals and release. This will automatically disengage the parking brake.

Electrical System

Electrical power is provided by a DC electrical system. The system includes a 28 volt, 43-ampere-hour lead acid battery, an optional standby 28 volt, 5-ampere-hour lead acid battery/power supply, a 28 volt, 300-ampere starter-generator, a generator control unit, a DC external power receptacle, and three relay boxes.

System switches are located on the instrument panel, and system circuit breakers are located on the circuit breaker consoles (Figure 8-1). The breakers are marked to indicate their function and amperage and are the trip-free, push-to-reset type. Additional circuit breakers are located on forward LH and RH circuit breaker panels (Boost/SAS/IFR installations).

The primary lead acid battery is located in the nose compartment of the aircraft. The BATT switch is a two position switch (ON/OFF), and is located on the left hand side of the instrument panel. When placed in the ON position, the battery switch connects the battery to the primary bus. The battery life with the generator off-line is approximately one hour.

NOTE

During normal operations, the standby battery switch must be ON to power the listed equipment (IFR aircraft only).

The optional standby lead acid battery is located in the nose compartment of the aircraft (if installed). The battery life with the generator and main battery off-line is approximately 60 minutes at 100% capacity (40 minutes at 80% capacity).

The standby battery switch is located next to the standby gyro. When placed to the on position, the switch connects the standby battery to the standby bus. The standby bus powers the following equipment:

1. No. 1 Radio
2. Altitude Encoder
3. HSI/Gyro
4. Rotor RPM
5. Audio Panel
6. Transponder
7. Standby Attitude Gyro
8. Instrument Flood Lights
9. Torque Gauges
10. Interior Lights (5 volt)

In the event of a generator and main battery failure, the standby battery will power the standby bus.

The starter-generator is mounted on the engine at the six o'clock position. The GEN switch is a three position switch (ON/OFF/RESET), and is located on the left side of the instrument panel. If the generator switch is ON and the starter-generator fails, the GENERATOR caution light on the caution/advisory panel will illuminate.

The generator control unit is located in the tail section of the aircraft; it monitors and controls the starter-generator's DC power output to the primary bus. The volt/ammeter located on the left side of the instrument panel gives a visual indication of the starter-generator's power output.

The DC external power receptacle is located on the forward left side of the aircraft nose section. It is designed to accept 28-VDC and is controlled by the EXT PWR switch located on the switch assembly panel. Placing the switch to the ON position connects the external power source to the primary bus. Whenever external power is connected and power utilized (switch in ON position) the EXT PWR advisory light (green) (battery light for IFR configuration) on the caution/advisory panel will illuminate.

The aft relay box is located in the aft fuselage while the miscellaneous and forward relay boxes are located in the nose compartment. They contain relays for control and distribution of power throughout the aircraft.

The avionics systems are powered by the avionics busses. The AVIONICS MASTER switch is located on the RH switch panel. When the AVIONICS MASTER switch is turned ON, both avionics busses are connected to the primary bus. The avionics master switch is located on the RH switch panel.

Lighting System

The lighting system includes aircraft position lights, strobe lights, an exterior search/landing light, and interior/instrument lights.

The LH and RH position lights are located near the base of each rotor shaft housing; a red strobe light is mounted between the two rotor shafts on the shear tie assembly; a second red strobe light is mounted under the fuselage, and the white navigation light is mounted on the tail. The strobe lights are controlled by the STROBE LIGHT switch and the position lights are controlled by the NAV LIGHTS switch, both on the switch panel assembly.

The aircraft may also be equipped with a third strobe light mounted on the shear tie adjacent to the existing anti-collision light. This strobe light is equipped with a red/clear lens to meet requirements of the U. S. Forest Service for fire fighting aircraft, and is only to be used when the aircraft is actively engaged in fire fighting operations. This light can be controlled independently of the anti-collision light system through use of the forestry beacon switch mounted on the cockpit instrument panel. All three strobe assemblies receive power from the same circuit breaker marked "STROBE LT".

The search/landing light is located under the nose of the helicopter, in front of the nose landing gear. The light can be swiveled 360° using the LAND LT 5-position switch on the collective lever switchbox. Push to activate and deactivate the light, and push switch fore/aft, left/right, to move the light.

Interior lighting consists of cockpit floodlights, located on the bulkhead behind the pilot seat, integral instrument lighting, and instrument panel floodlighting. The cockpit floodlights are controlled by the CPT FLOOD switch; the instrument floodlights and panel lighting are controlled by INST FLOOD and INST PNL rheostats, respectively. All interior lighting switches are located on the switch panel assembly.

IFR equipped aircraft include receptacles on the forward LH and RH side door frames to allow repositioning of the cockpit floodlights.

Heating/Ventilation System

The heating/ventilation system consists of an air inlet assembly, a bleed air valve on the engine, a fan assembly, an air distribution assembly, and associated controls. The system can deliver a controlled flow of either heated or unheated air to the cockpit and windshield areas.

The air inlet assembly is located under the cockpit floor on the left side of the helicopter. It is attached to the fuselage skin and has a screened opening to allow fresh air into the chamber. The air inlet assembly mixes the outside air with the heated air from the engine.

The bleed air valve, mounted on the engine, is electrically controlled by the CABIN HEAT/VENT switch located on the switch panel assembly. Placing the switch in the CABIN HEAT/VENT position opens the valve and allows bleed air to flow to the air inlet assembly. Placing the switch in the VENT position closes the valve.

The fan assembly is controlled by the CABIN HEAT switch on the switch panel assembly. When the switch is placed in either the CABIN HEAT /VENT or VENT position, power is supplied to the fan. A thermostat is installed in the housing. When the air temperature inside the housing exceeds the thermostat limit temperature, the thermostat opens the circuit which closes the bleed air valve. An EMI filter is mounted on the fan assembly to keep brush "noise" from reaching the 28-VDC bus and the radio equipment.

The air distribution assembly is mounted forward of the instrument panel and is mechanically controlled to direct air to either the windshield or the pilot's feet, or both.

The mechanical controls are located on the instrument panel. The TEMP knob controls the valve on the air inlet assembly. Pulling the knob out opens the valve allowing hot engine bleed air to enter the air inlet assembly. The HEAT/DEFROST knob controls the air distribution assembly and directs the air to the feet (HEAT) or to the windshield (DEFROST). Pulling the knob out directs the flow of air to the feet, pushing the knob in directs the flow of air to the windshield.

Instruments

The instrument panel includes standard flight instruments as well as all the indicating/recording instruments for the powerplant, related systems, and transmission (Figure 8-1). Also included is an instrument for measuring/recording total weight on the aircraft hook.

The powerplant and related systems instruments include a torque indicator, gas generator speed (N_G) indicator, EGT indicator, oil pressure/temperature indicator, fuel pressure and fuel quantity indicators. An oil pressure/temperature indicator for the transmission is also included. The standard flight instruments include an airspeed indicator, dual engine/rotor tachometer, altimeter, rate-of-climb indicator, turn and slip indicator, compass free/slave switch, and a Hobbs meter.

An artificial horizon and the installed Bendix/King KCS 55A Pictorial Navigation System provide aircraft attitude indication. A standby attitude indicator is located on the upper right hand side of the glare shield (if installed).

In addition to the system gauges, the instrument panel includes a master warning panel, caution/advisory panel, and two switch panels. The master warning panel is located on the lower left side of the instrument panel. It consists of three lights which read ROTOR (black/red background), FIRE (black/red background) and MAST CAUT (black/amber background). (Refer to cockpit indicator lights section 4 for meaning of ROTOR or FIRE light) The MAST CAUT light will illuminate when any caution light on the caution/advisory panel is energized. A RESET button is located to the right of the master warning panel. Once activated, the MASTER CAUTION light remains on until the RESET button is depressed.

The caution/advisory panel is located on the center of the instrument panel. The caution/advisory panel contains placard-type warning lights, each of which is monitored by one of the check circuits. If a malfunction or unsafe condition develops in any of the monitored systems, the caution light (amber) will illuminate until the condition has been corrected. A TEST button is located beneath the RESET button. Depressing the TEST button illuminates each of the lights on the master caution panel and the caution/advisory panel, and activates the built-in test features of the digital instruments.

One switch panel is located on the right side of the instrument panel, and carries switches and rheostats that control various aircraft system functions. The switches on the lower left side of the instrument panel include the battery, generator, fuel/oil valve, boost (if installed), and particle separator switches. Space on the instrument panel has also been provided for cockpit heat/defogging, rudder pedal trim, a clock, navigation/communication radios, and optional equipment.

An external instrument panel may be located on either side of the fuselage, just under the cockpit door (Figure 8-1). The panel houses a load indicator, torque indicator, N_R tachometer or EGT indicator, a MASTER CAUTION light, and a FIRE light.

Recording Instruments

General

Each of the recording instruments incorporates a redundant analog/digital display, an exceedance warning light, capacitance type touch switches (labeled STEP and RESET), a built-in test (BIT), a white ball flag, gauge error code reporting (6 codes – see the table), non-volatile memory for last flight and cumulative data recording, and each is password protected from inadvertent data download.

Each instrument is described in detail in subsequent paragraphs. The following is a list of error codes which are applicable to each recording instrument:

| <u>Error Codes</u> | <u>Code Description</u> |
|------------------------|--------------------------------------------------|
| Err 1 | Indicates a ROM Checksum error |
| Err 2 | Indicates a RAM error |
| Err 3 | Indicates an out of tolerance condition |
| Err 4 Opt 1 | Indicates pointer failed to clear optical sensor |
| Err 5 Opt 1 | Indicates pointer failed to block optical sensor |
| Err need CAL | Indicates calibration has been lost |

All of these failure codes indicate an inoperative instrument.

H1973-1 Load Indicator/Monitor (Before SB 036)

The digital accuracy of the gauge is ± 19.6 pounds from 0 to 9,800 pounds. The pointer accuracy is ± 20 pounds. A load cycle begins when the cargo hook weight exceeds 500 pounds and terminates when the cargo hook weight is less than 500 pounds. The weight of the load is averaged over the last 10 seconds of a 25 second period when the load on the cargo hook exceeds 500 pounds. A load is recorded only when a load cycle is 25 seconds or more and exceeds 500 pounds.

An exceedance warning light is flashed and a digital display is activated during the following conditions: (1) load exceeds 6,000 pounds with “lbs” display; (2) rotor speed exceeds 105% with a “rtr” display; (3) rotor speed less than 75% with “Lnr” display. A white ball flag is activated in the top center of the gauge when rotor speed exceeds 105% or load exceeds 6,000 pounds.

The last engine operation data can be checked on the gauge by touching the step switch once for each item in sequence. The following information is available:

NOTE

An engine operation, for this gauge, is defined as any time that N_R exceeds 30% and continues until N_R is less than 30%.

| <u>Data</u> | <u>Indication</u> |
|----------------------------------------------|---------------------------------|
| Load cycles (#) | L-C= |
| Peak load (lbs) | P-L= |
| Duration of load exceedance (sec) | t-L= |
| Peak N_R (%) | Pnr= |
| Duration of N_R exceedance (sec) | tnr= |
| Ball flag code (# of codes) | b1 (load), b2 (N_R) or both |

H1973-2 Load Indicator/Monitor (Aircraft with SB 036 Installed or Aircraft Serial Number A94-0015 or Higher)

The digital accuracy of the gauge is ± 19.6 pounds from 0 to 9,800 pounds. The pointer accuracy is ± 50 pounds. The automatic load cycle begins when the cargo hook weight exceeds 500 pounds and terminates when the cargo hook weight is less than 500 pounds. The manual load record is obtained when the LOAD RCD button is depressed. The button is typically located on the collective stick switchbox assembly. The weight of the load is averaged over the last 10 seconds of a 25 second period when the load on the cargo hook exceeds 500 pounds. A load is recorded only when a load cycle is 25 seconds or more and exceeds 500 pounds.

An exceedance warning light is flashed and a digital display is activated during the following conditions: (1) load exceeds 9,000 pounds (“lbs” or “SI” will be displayed); (2) rotor speed less than 70% with “Lnr” display. A white ball flag is activated in the top center of the gauge when rotor speed exceeds 115% or load exceeds 9,000 pounds.

The last engine operation data can be checked on the gauge by touching the step switch once for each item in sequence. The following information is available:

NOTE

An engine operation, for this gauge, is defined as any time that N_R exceeds 30% and continues until N_R is less than 30%.

| <u>Data</u> | <u>Indication</u> |
|----------------------------------------------|--------------------------------------------|
| Load cycles (#) | L-C= |
| Peak load (lbs) | P-L= |
| Loads in exceedance bin | Code/ XXXX |
| Peak N_R (%) | Pnr= |
| Duration of N_R exceedance (sec) | tnr= |
| Ball flag code (# of codes) | b0 (no exceedance), b1(N_R), b2 (load) |

For a comprehensive description of the unit and its operating procedures, refer to the appropriate Howell publication.

H1943-1 Torque Indicator/Monitor (Before SB 026)

NOTE

An overtorque condition illuminates the master caution light as well as the TORQUE segment on the warning/advisory light panel (torque exceeding 58 psi). The master caution light will remain on after the torque light is out.

The digital accuracy of the gauge is ± 0.6 psi from 0 to 75 psi. The pointer accuracy is ± 0.15 psi.

An exceedance warning light is flashed and a digital display is activated whenever torque exceeds 58 psi. A white ball flag is activated in the top center of the gauge whenever an exceedance occurs.

An engine operation, for this gauge, is defined as any time that torque exceeds 20.0 psi and continues until torque is less than 5.0 psi for longer than 300 seconds. Asterisk items may be accessed in flight.

The last engine operation data can be checked at the gauge as follows:

| <u>Data</u> | <u>Indication</u> |
|-------------------------------------------------|-------------------|
| *Peak torque (psi) | t-P= |
| *Duration of torque exceedance (sec) | t-L= |
| *Ball flag code (torque > 58 PSI) (#) | b1 |

The historical cumulative data that can be checked at the gauge are as follows:

| <u>Data</u> | <u>Indication</u> |
|---------------------------------------------|-------------------|
| Torque > 58 psi (#) | 58E= |
| Duration of torque > 58 psi (sec) | C-L= |

H1943-7 Torque Indicator/Monitor (Aircraft with SB 026 Installed or Aircraft Serial Number A94-0015 or Higher)

NOTE

An overtorque condition illuminates the master caution light as well as the TORQUE segment on the warning/advisory light panel (torque exceeding 59 psi). The master caution light will remain on after the torque light is out.

The digital accuracy of the gauge is ± 6 psi from 0 to 75 psi. The pointer accuracy is ± 0.15 psi. An exceedance warning light is flashed and a digital display is activated whenever torque exceeds 59 psi. Ball flag codes, red warning lamp, and switch closure are all activated in accordance with Table 8-1.

Table 8-1. Torque Exceedance Table

| Exceedance Condition | Ball Flag Code | Red Warn Lamp | Switch Closure |
|-----------------------------------------------------|----------------|---------------|----------------|
| No Exceedance (No Flag) | B0 | No | No |
| Torque > 59.0 PSI | B0 | Yes | No |
| Torque > 60.0 PSI | B0 | Yes | Yes |
| Torque > 68.0 PSI | B1 | Yes | Yes |
| $N_2 > N_2$ vs. Torque | B2 | No | No |
| Transmission damage fraction for operation ≥ 1 | B3 | No | No |

An engine operation, for this gauge, is defined as any time that N_2 exceeds 30% and continues until N_2 is less than 30%. The following most recent engine operation data can be checked at the gauge by stepping through the displays.

| <u>Data</u> | <u>Indication</u> |
|--------------------------------------------|-------------------|
| Peak torque | t-P= |
| Sum of transmission damage fractions | ttF |
| Ball flag code | bXX |

The historical cumulative data can also be checked by maintenance personnel. For a comprehensive description of the unit and its operating procedures, refer to appropriate Howell publication.

H1901-1 N_G Indicator/Monitor

The digital accuracy of the gauge is $\pm 0.2\%$ RPM. The pointer displacement will be within ± 0.47 angular degrees of the digital indication.

A red exceedance warning light is flashed and a digital display is activated whenever N_G is equal to or greater than 105.0% N_G. A white ball flag is activated whenever N_G exceeds 105.0%.

An engine operation, for this gauge, is defined as any time that N_G exceeds 28 percent and continues until engine speed becomes less than 28 percent. Asterisk items may be accessed in flight.

The last engine operation data can be checked at the gauge as follows:

| <u>Data</u> | <u>Indication</u> |
|------------------------------------------------------|-------------------|
| *Peak N _G engine speed (%) | ES.P= |
| Ball flag code (N _G > 105%) (#) | b1 |

There are no historical cumulative data on this gauge.

H1900K-2 EGT Indicator/Monitor (Before SB 035)

The digital accuracy of the gauge is $\pm 3^\circ\text{C}$ EGT and $\pm 0.2\%$ RPM N_G. The pointer accuracy is ± 1.0 angular degree of the digital indication.

A red exceedance warning light is flashed whenever EGT is greater than the maximum continuous limit. A steady red exceedance warning light is illuminated when one of the following conditions is met: (1) EGT exceeds the takeoff limit, or (2) N_G speed is greater than 105.0% RPM. A white ball flag is activated in the top center of the gauge whenever: (1) EGT exceeds the takeoff limit by two degrees, or (2) N_G speed is greater than 105.0% RPM.

An engine operation, for this gauge, is defined as any time that N_G exceeds 30% and continues until N_G RPM is less than 30%. Asterisk items may be accessed in flight.

The last engine operation data that can be checked at the gauge are as follows:

| <u>Data</u> | <u>Indication</u> |
|------------------------------------------------------|-------------------|
| Peak EGT ($^\circ\text{C}$) | Et.P= |
| Peak N _G engine speed (%) | ES.P= |
| Ball flag code (EGT > limits) (#) | b1 |
| Ball flag code (N _G > 105%) (#) | b2 |
| HIT data (Last 9 records) (Refer to Section 10) | |

The historical cumulative data that can be checked at the gauge are as follows:

| <u>Data</u> | <u>Indication</u> |
|-------------------------------------------------------------|-------------------|
| *Engine serial number | ESn= |
| *Flights (#) | FL= |
| *Gas producer cycles | LCF1 |
| *Compressor cycles | LCF2 |
| *Power turbine cycles | LCF3 |
| *Engine operation hours | OP.H= |
| *Flight hours | FL.H= |
| *Takeoff temp. limit events (#) | E.tO= |
| *Duration of takeoff exceedance (sec) | t.t= |
| *Max continuous temp limit events (#) | E.C= |
| *Duration of max continuous exceedance (sec) | C.t= |
| *N _G is greater than 105.0% events (#) | 105E |
| *Time N _G is greater than 105.0% (sec) | 105t |

H1900K-22 EGT Indicator/Monitor (Aircraft with SB 035 Installed or Aircraft Serial Number A94-0015 or Higher)

The digital accuracy of the gauge is $\pm 3^{\circ}\text{C}$ EGT and $\pm 0.2\%$ RPM N_G. The pointer accuracy is ± 1.0 angular degree of the digital indication.

A red exceedance warning light is flashed whenever EGT is greater than the maximum continuous limit. A steady red exceedance warning light is illuminated when EGT exceeds the takeoff limit. A white ball flag is activated in the top center of the gauge whenever: (1) EGT exceeds the takeoff limit by two degrees, or (2) N_G speed is greater than 105.0% RPM. For a comprehensive description of the unit and its operating procedures, refer to appropriate Howell publication.

An engine operation, for this gauge, is defined as any time that N_G exceeds 30% and continues until N_G RPM is less than 30%. Asterisk items may be accessed in flight.

The last engine operation data that can be checked at the gauge are as follows:

| <u>Data</u> | <u>Indication</u> |
|------------------------------------------------------|-------------------|
| Peak EGT ($^{\circ}\text{C}$) | Et.P= |
| Peak N _G engine speed (%) | ES.P= |
| Ball flag code (EGT > limits) (#) | b1 |
| Ball flag code (N _G > 105%) (#) | b2 |
| HIT data (Last 9 records) (Refer to Section 10) | |

The historical cumulative data that can be checked at the gauge are as follows:

| <u>Data</u> | <u>Indication</u> |
|-------------------------------------------------------------|-------------------|
| *Engine serial number | ESn= |
| *Flights (#) | FL= |
| *Gas producer cycles | LCF1 |
| *Compressor cycles | LCF2 |
| *Power turbine cycles | LCF3 |
| *Engine operation hours | OP.H= |
| *Flight hours | FL.H= |
| *Takeoff temp. limit events (#) | E.tO= |
| *Duration of takeoff exceedance (sec) | t.t= |
| *Max continuous temp limit events (#) | E.C= |
| *Duration of max continuous exceedance (sec) | C.t= |
| *N _G is greater than 105.0% events (#) | 105E |
| *Time N _G is greater than 105.0% (sec) | 105t |

Pitot-Static System

The pitot-static system consists of a single pitot head located under the nose of the helicopter, a static port located on both the left and right sides of the fuselage nose, and the tubes and clamps which connect them to the flight instruments.

The pitot head directs ram air pressure to the airspeed indicator, while the static port directs static (ambient) air pressure to the altimeter, airspeed indicator, and rate-of-climb indicator. The pitot head and static ports contain a heating element to prevent icing and subsequent blockage; the heating element is controlled by a PITOT HEAT switch on the switch panel assembly. Should the static ports become blocked, an alternate static air source inside the cockpit may be selected by pulling the alternate static air source knob located on the lower right side of the instrument panel (IFR aircraft only).

Pilot Seat

WARNING

The pilot seat is spring loaded; adjust only while occupied. Since the seat relies on vertical movement to function properly, do not place articles or equipment under the seat.

The pilot seat has an energy absorbing system that allows it to stroke vertically under certain conditions. This vertical stroking is required to limit excessive pilot spinal loading in the event of an aircraft mishap.

The seat is equipped with a five-point restraint system that includes two lap belts, two shoulder straps, and a tiedown strap. The top of the shoulder straps are attached to an inertia reel that can be either locked or unlocked. Unlocked, the reel allows the straps to unwind. Locked, the straps retract only. The inertia reel lock handle is located on the left side of the seat. Move the handle forward to lock the reel, aft to unlock the reel.

External Load System

The cargo hook is located on the underside of the aircraft, mounted on the fuselage centerline. The cargo hook has a capacity of 6,000 pounds. Belleville washers at the three connecting points eliminate hook movement when no load is attached.

The hook can be operated electrically or manually. The electric release circuit is energized by the HOOK ARM/SAFE switch on the collective stick switchbox. A CARGO RELEASE button is located on the cyclic stick grip and/or collective stick switchbox, and actuates the release solenoid in the hook. When the load is released, the hook must be manually returned to the closed and locked position. There is no minimum load requirement for cargo hook release.

The electric release circuit contains two circuit breakers: a 25-ampere CARGO HOOK CB located in the forward relay box assembly, and a 3-ampere CARGO HK CB located on the circuit breaker panel assembly.

To release the hook manually, the pilot squeezes the manual release handle, located on the collective stick. The handle is connected to the hook by a flexible cable running along the bottom of the fuselage.

The cargo hook junction box, located forward of the hook, contains four connectors: one each for the cargo hook, load link, long line, and optional Sacksafoam.

The load link provides a weight-on-hook signal, via the signal conditioner, to the load indicator on the instrument panel.

The long line, when installed, permits pilot control over a remote hook located at the end of a cable. The long line hook can only be operated electrically.

The long line circuit is energized by the HOOK ARM/SAFE switch on the collective stick switchbox. LONG LINE release button(s), may be located on the cyclic stick grip and/or on the collective stick switchbox, and actuate the release solenoid in the hook.

The long line electric release circuit contains two circuit breakers: a 50-ampere LONG LINE CB located in the forward relay box assembly, and a 3-ampere LONG LINE CB located on the circuit breaker panel assembly.

Dual Cargo Hook Release for Long-Line (Optional SB 074)

The aircraft may be modified to provide for releasing loads from two hooks on the end of a longline assembly. This “dual” hook on the long-line allows the pilot to select a single hook for release, or both hooks for release with another long-line release switch. These switches are mounted on the cyclic grip and/or collective switch box.

C60 Multi-Hook Carousel (SB 066)

CAUTION

Special consideration must be given to the carousel selector switch position. Inadvertent jettison of an external load could result if the pilot assumes the selector switch is in the LAND LT position when it is in the HOOKS position. Before conducting carousel load operations or landing light operations with the carousel selector switch installed, the pilot should ensure that the selector switch position matches the light indication (HOOKS selected/light on, LAND LT selected/light off). If the switch position and light indication are conflicting, carousel operations should not be conducted.

The CANAM C60 Multi-Hook carousel is a four hook external load carrying system. The carousel system is attached to the aircraft mounted cargo hook.

The electric carousel release circuits are energized by the hook arm/safe switch on the collective stick switchbox. The four hooks on the carousel system are controlled by a combination of the selector panel switch and the landing light switch. The selector switch is mounted on the RH switch panel on the instrument panel and controls the operation of the landing light switch. When the selector switch is placed in the HOOKS position, a green light illuminates on the selector panel, and the landing light four way switch controls the hook release for each of the four individual hooks. Pushing the landing light switch in each of the four cardinal directions activates the release mechanism on each of the four carousel hooks. When the selector switch is placed in the LAND LT position, the green light extinguishes, and the landing light four-way switch controls the landing light. The carousel electric circuit is connected to, and protected by, the long line electric release circuit. The long line harness can not be used with the carousel installation. For a comprehensive description of the unit, and its operating procedures, refer to the appropriate CANAM publication.

AIM 510 Attitude Gyro (Standard Aircraft)

The AIM 510 attitude gyro is fully gimballed and capable of 360° of freedom in both the pitch and roll axes. The pitch axis is marked in 5° increments up to 25° nose up or down. The roll axis is marked in 10° increments up to 30° angle of bank with additional markings at 60° angle of bank.

The aircraft attitude reference mark can be adjusted with the adjustment knob located at the lower center of the gyro. The gyro can be quickly caged by pulling the fast erect knob on the lower right portion of the gyro.

A red/white flag will be displayed in the upper left portion of the gyro any time DC power is not applied. The gyro is accurate to within 3° of pitch and roll.

The lower portion of the gyro is equipped with a slip indicator.

AI-330 Attitude Indicator (IFR Aircraft Only)

The AI-330 attitude indicator is used to display aircraft pitch and roll attitudes. The attitude indicator is mounted on the RH side of the instrument panel above the HSI. The indicator consists of a two degree of freedom gyroscope, a display sphere mechanically linked with the gimbals of the gyroscope, a gimbal caging mechanism, a miniature airplane assembly, a power warning flag and electronic circuit card assemblies mounted on a ridged machined frame inside a cover.

It is capable of operation through 360° of aircraft pitch and roll displacement. The pitch axis is marked in 5° increments while the roll axis is marked in 10° increments up to 30° angle of bank and then in 30 increments up to 90° angle of bank. The gyro can be quickly caged by pulling the caging knob marked PULL TO CAGE. The knob is located on the lower RH portion of the gyro.

In normal operation, the aircraft 28 VDC system powers the indicator. Should the aircraft 28 VDC system fail, the gyroscope wheel speed and the unique nature of the erection system combine to provide up to 9 minutes of usable attitude information. Interruption of input power to the indicator, placing the caging knob in the caged position, inadequate wheel speed, or the absence of internal power to the gyroscope will cause the power warning flag marked OFF to be displayed on the RH portion of the indicator.

The lower portion of the gyro is equipped with a slip indicator. For a comprehensive description of the unit and its operating procedures, refer to the appropriate B. F. Goodrich publication.

AI 804 Standby Attitude Indicator (If Installed)

The J.E.T. AI 804 attitude indicator is a compact, two-inch, self-contained standby gyro device. It is fully gimballed and capable of 360° of freedom in both the pitch and roll axes. The pitch axis is marked in 5° increments while the roll axis is marked in 10° increments up to 30° angle of bank with additional markings at 60° and 90° angle of bank. The aircraft attitude reference mark can be adjusted 5° of pitch with the knob located on the lower right hand portion of the gyro. Pulling on this knob will cage the gyro. The gyro is turned on by a switch located just to the left of the indicator. In normal operation, the aircraft 28 VDC system powers the gyro through the PS835 emergency power supply. The emergency power supply is capable of powering the standby attitude indicator for five hours. Should the aircraft 28 VDC system fail, the gyro will automatically be powered by the emergency power supply. The charge of the emergency power supply can be checked with the test position of the gyro switch and the green indicator light. Should all power to the indicator be lost, a flag will be displayed on the left portion of the indicator. Momentum of the internal gyro will allow useful flight information to be displayed for nine minutes. For a comprehensive description of the unit and its operating procedures, refer to the appropriate J.E.T. publication.

KCS 55A Compass System

The Bendix/King KCS 55A compass system consists of a KI 525A horizontal situation indicator (HSI), a KA 51B slaving control and compensator unit, a KMT 112 magnetic slaving transmitter, and a KG102A directional gyro. Both the HSI and slaving control are located on the instrument panel. The magnetic slaving transmitter is located in the aircraft tail and the directional gyro is located in the nose compartment. For a comprehensive description of the system and its operating procedures, refer to the appropriate Bendix/King publications.

KR22 Marker Beacon (If Installed)

The Bendix/King KR22 panel mounted marker beacon receiver operates at 75.00 MHz and provides visual and aural indication of passage over marker beacon stations. Blue, amber, and white lamps on the receiver panel will light depending on which marker beacon station the aircraft is passing over. The signal from the outer marker causes the blue lamp to light, while the middle marker signal lights the amber lamp and the inner marker signal lights the white lamp. The switch controls primary power and selects bright or dim lamp intensity. A test function causes all three lamps to momentarily light when the switch is moved from OFF to the BRITE or DIM position. For a comprehensive description of the unit and its operating procedures, refer to the appropriate Bendix/King publication.

KX 165 VHF Navigation/Communication Transceiver

The Bendix/King KX 165 is a self-contained, panel mounted VHF navigation and communication radio. It is equipped with self-dimming digital readouts for display of both active and standby navigation and communication frequencies. The frequency range covers all 200 NAV and 760 COMM frequencies. The communication transmitter power is rated at 10 watts (minimum). For a comprehensive description of the unit and its operating procedures, refer to the appropriate Bendix/King publication. The second KX165 radio (if installed) provides only communications capability.

Hobbs 85000 Hour Meter

The Hobbs 85000 DC powered quartz hour meter indicates flight time in hours and tenths from zero to 999.9 hours. There is a running indicator next to the tenths digit that will cycle whenever the meter is running.

M800 Digital Chronometer

The Davtron M800 is a DC powered quartz clock. Power is provided by both the aircraft and the internal battery. The liquid crystal display will be active anytime aircraft power is provided. The controllable display can provide Greenwich Mean Time (GMT) in a 24 hour format, Local Time (LT) in a 12 hour format, an Elapsed Time (ET) counter from 1 second to 99 hours and 59 minutes, or Elapsed Time countdown time with a flashing alarm from 1 second to 1 hour. For a comprehensive description of the chronometer refer to the appropriate Hobbs publication.

LC-6 Clock

The Astrotech LC-6 clock is a six digit, five function digital chronometer. The unit has an LCD display, backlit by the aircraft dimming system. The internal battery maintains power when the aircraft is off. The clock provides local time of day in a 12-hour format, Coordinated Universal Time in a 24-hour format, flight time, stop watch functions, and a countdown feature. For a comprehensive description of the unit and its operating procedures, refer to the appropriate Astrotech publication.

KT 70 Transponder

The Bendix/King KT70 is a panel mounted transponder designed to fulfill the role of airborne beacon equipment. It is equipped with a gas discharge display, Mode Select knob, VFR pushbutton, Ident pushbutton, and four ident code selector knobs. It is capable of Modes A, C, and S operations. Mode and code selection are performed by the rotary knobs, and all functions including flight level altitude, identification code, and aircraft address are presented on the gas discharge display. For a comprehensive description of the system and its operating procedures, refer to the appropriate Bendix/King publication.

KLN 90 GPS

NOTE

When the CDI switch is in the GPS position, the normal ambiguity (to/from) functions of the HSI are inoperative and the course selector function of the HSI has no effect on displacement of the CDI. CDI displacement is in relationship to a course selected by the GPS receiver, regardless of the course selected on the HSI.

The Allied Signal KLN 90 GPS is a self-contained, panel mounted, Global Positioning System (GPS) receiver. The unit provides precise airborne navigation information. The unit can use its present position information to determine crosstrack error, distance-to-waypoint, groundspeed, track angle, time-to-waypoint, bearing-to-waypoint, and advisory VNAV guidance. The front face contains a CRT display and all required controls. A GPS antenna located on top of the tail sends satellite positioning data to the receiver. A connector on the instrument panel allows the Jeppesen Sanderson database to be updated from a computer. The three position CDI switch located on the instrument panel allows the CDI to display NAV 1, NAV 2, or GPS course deviation on the HSI. For a comprehensive description of the system and its operating procedures, refer to the appropriate Allied Signal publication.

AA22-110 PA System (Siren/Loudhailer)

The NAT AA22-110 public address (PA) system provides a centralized control for external audio paging and a siren for alerting. The system consists of a control panel mounted on the overhead console, an amplifier located in the nose compartment, and a 100-watt speaker mounted to the bottom of the main landing gear boom. The siren (if installed) is activated by momentarily depressing a switch on the collective stick; or it may also be activated from the control panel.

AA12-001 Audio Panel

The NAT AA12-001 audio panel is a compact audio controller which interfaces with the KX 165 VHF radio, TFM138B FM radio, AA22-110 PA system control panel, low rotor warning unit, and the external ICS port located in the nose compartment. For a comprehensive description of the unit and its operating procedures, refer to the appropriate NAT publication.

TFM138B FM Transceiver

The Technisonic TFM138B (if installed) is a self-contained, panel mounted, FM communications transceiver. The unit is capable of operating in the 138 to 174 MHz frequency range in 2.5 KHz increments. The transceiver provides 25 memory positions, each capable of storing a transmit frequency, receive frequency, transmit frequency CTCSS tone, receive frequency CTCSS tone, and an alphanumeric identifier for each channel. Operating frequency and related data are displayed on a 48-character, two line LED matrix display. Transmitter output power is 10 watts maximum. For a comprehensive description of the unit and its operating procedures, refer to the appropriate Technisonic publication.

Aural Warning System (After SB-094)

The aural warning system (AWS) compliments the existing Caution Advisory System by providing essential warnings and advisories in a verbal format through the audio system. The system annunciates fire, high and low torque, clutch overrun, slipping clutch, and high and low rotor RPM warnings/advisories. The AWS is deactivated (except for BIT function) when the A/C is on the ground. However, the primary (visual) caution advisory system remains active.

A system BIT exercises the AWS when the instrument panel TEST button is pressed; however, some warnings may occur more than once as BIT conditions shift. TEST button activation results in CAP illumination of all warning/advisory segments and also begins the test sequence within the AWS. BIT initiated aural warnings and advisories into the audio system are controlled by the BIT ENABLE/BIT DISABLE switch on the Aural Warning Control Box located behind and to the left of the pilot. BIT annunciations can only be heard if the BIT switch is in the BIT ENABLED position. Having the BIT switch in the BIT DISABLED position only restricts BIT generated annunciations and does not affect normal AWS in-flight operation.

Due to the random state of the system upon BIT activation, the TEST button should be held until the "Fire, Fire, Fire" and "Torque High" warnings are annunciated, then released, allowing the remaining warnings/advisories to be heard.

During BIT, each of the following annunciations will be triggered at least once. The AWS is functional/ready for flight if all messages have annunciated.

1. "Fire, Fire, Fire"
2. "Torque High"
3. "Torque Low"
4. "Clutch Overrun"
5. "Slipping Clutch"
6. "High Rotor RPM"
7. "Low Rotor RPM"

In the case of single warning or advisory activation during flight it will continue to annunciate until its cause is within acceptable parameters or until the instrument panel RESET button is pressed. Once reset, the individual warning or advisory will not annunciate again until its parameters drop back to acceptable levels and are again exceeded.

In the case of multiple warnings or advisories during flight, each warning will be annunciated at least once on a first in/first out basis. Pressing the RESET button during annunciation of multiple messages will only stop repetitive annunciation of the warning or advisory being annunciated when the RESET button is pressed. As with a single warning or advisory annunciating when the RESET button is pressed, the warning or advisory annunciating when the RESET button is pressed will not annunciate again until its parameters have dropped back to acceptable levels and are again exceeded; other warnings or advisories remaining active will continue to annunciate after the RESET button is pressed. Each warning or advisory in a multiple warning/advisory annunciation can be individually "reset" in the above manner using the RESET button.

The aural warning control box controls and indicators are as follows:

1. OVERRUN EVENTS and SLIP EVENTS indicators provide a counting of these events for use in A/C maintenance evaluations.
2. AUDIO LEVEL control allows the pilot to adjust the AWS annunciation volume to a level above a preset minimum audio level.
3. LOW TORQUE SET control allows for adjustment of the low torque aural warning threshold to be set to a value just before a low torque warning is announced by the AWS. This setting may need to be adjusted to allow for increased torque margin prior to clutch overrun. The LOW TORQUE control has settings of 1, 2, 3.5, 5, 6, 7.5, 8.5 and 10 PSI, with the 3.5 through 10 PSI settings being the effective settings. The adjustment of this will depend on several factors. The initial setting is 5 psi. The following are possible adjustments:
 - a. If the LOW TORQUE audio warning is activating regularly with no corresponding increase indicated on the clutch overrun counter adjust the LOW TORQUE SET knob down in small increments and monitor the overrun counter regularly.
 - b. If no LOW TORQUE audio warning is annunciating but the overrun counter indicates overrun events adjust the LOW TORQUE SET knob up in small increments and monitor the overrun counter regularly.

Section 9 Handling and Servicing

Contents

| | |
|-------------------------------------------|-----|
| Parking the helicopter | 9-2 |
| Folding rotor blades | 9-2 |
| Unfolding rotor blades | 9-4 |
| Blade tiedown | 9-5 |
| Towing/pushing the helicopter | 9-5 |
| Gravity fueling | 9-6 |
| Pressure fueling | 9-6 |
| Fueling with anti-ice additives | 9-6 |
| Servicing engine oil | 9-6 |
| Servicing transmission oil | 9-7 |
| Servicing hydraulic oil | 9-7 |
| Servicing tires | 9-8 |
| Installing protective covers | 9-8 |
| Servicing table | 9-8 |

Parking the Helicopter

These steps may be followed if prevailing winds are 15 knots or less. If the helicopter is to be parked in winds greater than 15 knots, refer to KMM, Chapter 10 for more specific procedures.

Ground handling on smooth level operating areas can best be accomplished by having three or four people push the helicopter and using the tilly bar to steer. The landing gear boom assembly is the best area to push on to move the aircraft. If it is necessary to tow the aircraft, attach a standard tow bar to the nose gear to move the aircraft.

1. If possible, maneuver helicopter into prevailing winds. Ensure blades are clear of all obstacles.
2. Set parking brake by depressing both brake pedals while pulling up on parking brake handle.
3. Lock nose gear by aligning nose strut in fore-and-aft position and move nose gear lock handle to LOCKED position.
4. Chock main landing gear wheels.
5. Position blades parallel. Blades should remain in this position any time helicopter is parked and blades are not folded.
6. Apply rotor brake.
7. Install pitot tube cover.
8. Install engine exhaust cover.
9. If helicopter is being parked inside hangar, attach grounding cable and disconnect battery.

Folding Rotor Blades

CAUTION

Rotor blades must not be deflected downward more than six inches at the tips. Never reach up and pull down blade tips. Whenever blades are folded, extend tiedown ropes out 45° from tips to prevent preloading. Never move flight controls with blades in folded position. Do not attempt to rotate blades while folded.

1. Release rotor brake.
2. Rotate forward RH blade to 90 degree angle in relation to helicopter centerline.
3. Slip hooked end of tiedown rope through tipcap fitting at end of blade.
4. Rotate LH blade to 90 degree angle in relation to helicopter centerline.
5. Slip hooked end of tiedown rope through tip cap fitting at end of blade.

6. Rotate blade assemblies until hubs are parallel at a 45 degree angle in relation to helicopter centerline, with forward tips to right side and aft tips to left side of aircraft. Hubs should be located approximately at one and seven o'clock positions.
7. Apply rotor brake.
8. Pull out lockpins of LH hinged (lead) stops and let stops hang down out of the way.
9. Put two blade folding locks of LH rotor into folding position by lifting up and out on locks.
10. Rotate LH blades in direction of rotation until both folding locks fully engage blade grips.
11. Pull out lockpins of RH hinged (lead) stops and let stops hang down out of the way.
12. Put two blade folding locks of the RH rotor into folding position by lifting up and out on locks.

CAUTION

Be careful that blade servo flaps do not contact each other.

13. Rotate RH blades opposite to direction of rotation until both folding locks fully engage blade grips.
14. Secure two aft tiedown ropes to tiedown rings.
15. Install blade lock assembly between two forward blades as follows
 - a. Place lock assembly on blades at approximately station 36.0 with large pads resting on top of blades.
 - b. Slide entire assembly inboard until fittings rest against first bolt head on blade grips.
 - c. Secure traps around blades, making sure that rubber pads are in contact with blade surfaces.
16. Secure two forward tiedown ropes to the tiedown rings.

Unfolding Rotor Blades

CAUTION

Whenever blades are to be unfolded, extend the tiedown rope out 45° from tip of blade to prevent preloading the blade. Make sure rotor brake is engaged.

1. Remove tiedown ropes from tiedown rings.
2. Starting with RH rotor blades, apply upward pressure on both folding lock hooks and simultaneously apply slight pressure on blade in direction opposite of rotation, thus removing preload and disengaging folding locks. Place folding locks in stowed position.
3. Walk blades in direction of rotation. Position both lag stops on rotor hub and secure with lockpins.
4. On LH rotor blades, apply upward pressure on both folding lock hooks and simultaneously apply slight pressure on blade in direction of rotation, thus removing preload and disengaging folding locks. Place folding locks in stowed position.
5. Walk blade in direction opposite of rotation. Position both lead stops on rotor hub and secure with lockpins.

NOTE

Only a certified mechanic can return the aircraft to service after unfolding blades.

6. After completing blade unfolding procedure, make sure that
 - a. All folding locks are in up and stowed position.
 - b. Lead stops on LH rotor are in normal operating position and secured. Lag stops on RH rotor are likewise secured.
 - c. All four droop stops are fully engaged.
7. Remove tiedown ropes.

Blade Tiedown

CAUTION

Rotor blades must not be deflected downward more than six inches at the tips. Never reach up and pull down blade tips. Whenever blades are folded, extend tiedown ropes out 45° from tips to prevent preloading. Never move flight controls with blades in folded position. Do not attempt to rotate blades while folded.

1. Release the rotor brake.
2. Install tiedown ropes.
3. Position rotor blades parallel.
4. Apply rotor brake.
5. Secure tiedown ropes to helicopter tiedown rings and draw ropes taut. Do not deflect blade tips more than six inches from the static droop position.

Towing/Pushing the Helicopter

CAUTION

During all ground handling operations it is extremely important to avoid excessive bending or flapping of the blades.

NOTE

A brake rider should remain in the aircraft during towing.

1. Position rotor blades at the eleven o'clock and five o'clock positions.
2. Apply rotor brake.
3. Lock nose wheel.
4. Attach tow bar to nose gear.
5. Release parking brake by depressing left pedal until the parking brake handle releases.
6. Remove wheel chocks.
7. Maneuver helicopter and park with blades clear of all obstacles.
8. Install wheel chocks.
9. Set parking brake by depressing both brake pedals while pulling up on parking brake handle.
10. Remove tow bar from nose gear.

Gravity Fueling

WARNING

Prior to fueling, grounding devices on aircraft, filling hose nozzle, and drag chains on fuel truck should be inspected for proper ground. Observe standard safety precautions prior to and during fueling.

CAUTION

Fuel loading can result in exceeding MGW. Since the top of the fuel filler neck is below the top level of the fuel cell, the cell cannot be completely filled. Do not rely on a visual check of fuel level in filler neck to determine absolute quantity of fuel in the helicopter. Check fuel quantity indicator for accurate fuel level.

1. Ground helicopter.
2. Remove gravity filler cap.
3. Insert filler nozzle.
4. Fuel helicopter.
5. Remove fueling nozzle.
6. Install gravity filler cap.
7. Remove ground wires.

Pressure Fueling

This section intentionally left blank.

Fueling with Anti-Ice Additives

See Section 10.

Servicing Engine Oil

WARNING

MIL-L-23699 lubricating oil is an eye and skin irritant. Prolonged contact may lead to dermatitis. May cause respiratory system irritation under high temperature conditions. May contain tricresyl phosphate which has the potential to cause adverse health effects.

Intermixing oils of different brands should be avoided if possible. Intermixing oils of different types is prohibited except in an emergency.

1. Check oil level. If low, service as follows:
 - a. Open engine oil tank access panel.

NOTE

Fill tank only until oil reaches the upper line on the sight gauge.

- b. Remove cap from oil filler port and service tank with lubricating oil. See Section 10 for approved lubricants.

CAUTION

After initial run-up, check the sight gauge to ensure that sufficient oil remains in the tank.

- c. Install cap. Close access panel.

Servicing Transmission Oil

NOTE

Fill tank only until oil reaches the upper line on the sight gauge.

1. Check oil level. If low, service as follows
 - a. Open transmission oil tank access panel.
 - b. Remove cap from oil filler port and service tank with lubricating oil. See Section 10 for approved lubricants.
 - c. Install cap. Close access panel.

Servicing Hydraulic Oil

NOTE

Fill tank only until oil reaches the upper line on the sight gauge.

1. Check oil level. If low, service as follows
 - a. Open access door on LH rotor shaft fairing assembly.
 - b. Remove cap from oil filler port and service tank with hydraulic oil. See Section 10 for approved lubricants.
 - c. Install cap. Close access door.

Servicing Tires

WARNING

Do not inflate tires above their rated pressures. Do not use a high pressure or unregulated pressure source. Never stand beside sidewall of tire being serviced; stand forward or aft of tread. Nitrogen acts as a natural asphyxiant. Use in well ventilated area.

1. Inflate landing gear with nitrogen. If nitrogen is not available, use dry, compressed air.
2. Inflate main landing gear tires to 155 PSI. Inflate nose landing gear tire to 132 PSI.

Installing Protective Covers

There are several different protective covers for the K-MAX helicopter. The use of these covers is recommended during inclement weather conditions or aircraft storage. For detailed information, refer to the K-MAX Maintenance Manual (KMM).

Servicing Table

Table 9-1 indicates servicing requirements for listed items.

Table 9-1. Servicing Table

| Item | Servicing Value |
|-----------------------------------------|---------------------------------------------------------------------------------------------------------------------------------------------------------------------------|
| Engine oil | Upper line on sight gauge (3.21 gal). Difference from full and low line is one quart. |
| Hydraulic oil (BOOST) (After SB 070) | Upper line on sight gauge (3.21 gal). Difference from full and low line is one quart. |
| Transmission oil | Upper line on sight gauge (3.21 gal). Difference from full and low line is one quart. (Note: normal servicing will be at the low line with the aircraft operating.) |
| Rotor dampers | 21 – 24 Pounds on bench |
| Rotor brake | 250 PSI air in accumulator |
| Tire pressure – Main | 155 PSI |
| Tire pressure – Nose | 132 PSI |
| Main landing gear strut | 35 PSI |
| Nose strut | 105 PSI while jacked |
| Collective limiter | 120 PSI @ 100°F 105 PSI @ 32°F 90 PSI @ -40°F |

Section 10 Supplemental Information

Contents

| | |
|----------------------------------------------------------------------|-------|
| Engine health indicator test (HIT) check | 10-2 |
| Fuel requirements | 10-4 |
| Specified fuels | 10-4 |
| Wide cut and kerosene type engine fuels and freezing points | 10-4 |
| Wide cut type equivalent fuels | 10-5 |
| Kerosene type equivalent fuels | 10-6 |
| Additives | 10-7 |
| Engine oil requirements | 10-8 |
| Approved transmission oils | 10-9 |
| Approved hydraulic oils | 10-10 |
| Extreme weather operation | 10-11 |
| Abnormal weather | 10-11 |
| Cold weather and arctic operation | 10-11 |
| Hot weather and desert operation | 10-12 |
| Functional check flight information | 10-12 |
| Rigging checklist | 10-12 |
| Slope Landing | 10-18 |
| Operations by Austrian registered helicopters | 10-18 |

Engine Health Indicator Test (HIT) Check

NOTE

EGT is displayed on indicator pointer at all times during HIT check. Touch RESET switch at any time to cancel HIT check and return to normal EGT indication.

The HIT check, performed on the ground, is utilized for trend monitoring. Large ($\pm 20^{\circ}\text{C}$) or increasing daily HIT values indicate possible engine maintenance required. Items affecting HIT values are dirty engine, air leaks, anti-ice or cabin heat on, etc. Refer to K-1200 KMM for maintenance procedures.

1. Start engine and engage rotors. Let temperatures stabilize.
2. Bring N_G above 80%. Touch EGT gauge STEP switch.
3. After two seconds the display will alternate between "tA.H=" and " $\pm XX.X$ ", where $XX.X$ is the actual OAT in $^{\circ}\text{C}$.
4. After five seconds, the indicator will display target N_G speed.
5. Slowly increase engine power until actual indicated N_G equals target N_G .
6. Maintain stabilized $N_G \pm 0.5\%$ for ten seconds.
7. After ten seconds, the indicator will display " $\pm XX$," where XX is the recorded HIT check ΔEGT .
8. After ten seconds, the indicator will return to normal EGT indication.

NOTE

ΔEGT is calculated from the HIT conversion table (Table 10-1) using the formula "aircraft EGT" - "table baseline EGT" = "HIT value".

Table 10-1. HIT Conversion Table

| Read OAT °C | Set N _G (%) | Baseline EGT °C | Read OAT °C | Set N _G (%) | Baseline EGT °C |
|----------------|---------------------------|--------------------|----------------|---------------------------|--------------------|
| -32 | 78.7 | 308 | 10 | 85.3 | 453 |
| -30 | 79.0 | 316 | 12 | 85.6 | 459 |
| -28 | 79.3 | 324 | 14 | 85.9 | 465 |
| -26 | 79.6 | 331 | 15 | 86.0 | 468 |
| -24 | 80.0 | 339 | 16 | 86.1 | 471 |
| -22 | 80.3 | 347 | 18 | 86.4 | 476 |
| -20 | 80.6 | 354 | 20 | 86.7 | 482 |
| -18 | 80.9 | 362 | 22 | 87.0 | 488 |
| -16 | 81.2 | 369 | 24 | 87.3 | 493 |
| -14 | 81.6 | 376 | 26 | 87.6 | 498 |
| -12 | 81.9 | 383 | 28 | 87.9 | 504 |
| -10 | 82.2 | 390 | 30 | 88.2 | 509 |
| -8 | 82.5 | 397 | 32 | 88.5 | 514 |
| -6 | 82.8 | 403 | 34 | 88.8 | 519 |
| -4 | 83.1 | 410 | 36 | 89.1 | 524 |
| -2 | 83.4 | 416 | 38 | 89.4 | 529 |
| 0 | 83.7 | 423 | 40 | 89.7 | 534 |
| 2 | 84.0 | 429 | 44 | 90.2 | 543 |
| 4 | 84.3 | 435 | 46 | 90.5 | 548 |
| 6 | 84.6 | 441 | 48 | 90.8 | 553 |
| 8 | 84.0 | 448 | 50 | 91.1 | 559 |

Fuel Requirements

Specified Fuels

WARNING

When using kerosene fuels (JP-5/JET A), restarting engine during flight is possible up to an altitude of 8,000 feet maximum. Use of these fuels should be avoided when starting at ambient temperatures below 10°F (-12°C).

NOTE

There are no special restrictions or instructions for use of JP-4/JET B fuels, with the exception of restarting engine during flight being limited to altitudes up to 20,000 feet maximum.

The fuels specified for use in these engines conform to Military Specifications MIL-T-5624 and are either wide cut type fuels, grade JP-4, or kerosene type fuels, grade JP-5. Equivalent fuels, MIL-T-83133, grade JP-8, may be used.

Wide Cut and Kerosene Type Engine Fuels and Freezing Points

NOTE

Variations in wide cut fuel quality or the use of kerosene type fuels can increase the rate of carbon deposit on hot end parts, especially during long periods of steady-state operations. Accumulation of deposits can be minimized by changing power levels periodically during operation.

All engine fuels listed are fully approved for flight operation. In cases where fuels approved by Honeywell are not available and other fuels must be substituted, consult with:

Honeywell, Inc.
Honeywell Engine
3001 E. Airline
Phoenix AZ 85072-2181
Attention: Manager Military/Helicopter Enterprises

Wide Cut Type Equivalent Fuels

CAUTION

Commercial fuels are commonly made to conform to American Society for Testing and Materials (ASTM) specification D 1655. ASTM specification fuel does not contain anti-icing additives unless specified by bulk purchaser. Therefore, more care than usual must be taken with respect to water contamination and flight conditions when accepting such a fuel.

Commercial wide cut type fuels. The following wide cut fuels may be used:

| | |
|--------------|--------------------|
| American | American JP-4 |
| Arco | Arcojet B |
| B.P. Trading | BP A.T.G. |
| Cal-Tex | Cal-Tex Jet B |
| Continental | Conoco JP-4 |
| Exxon | Exxon Turbo Fuel B |
| Gulf | Gulf Jet B |
| Mobil | Mobil Jet B |
| Phillips | Philjet JP-4 |
| Shell | Aeroshell JP-4 |
| Texaco | Texaco Avjet B |
| Union | Union JP-4 |

Military wide cut type fuels, freezing point -58°C (-72°F):

| | |
|----------------|---------------------|
| NATO | F-40 |
| Belgium | BA-PF-2B |
| Britain | D. Eng. R.D. 2486 |
| Canada | 3-GP-22f |
| Denmark | MIL-T-5624, GR JP-4 |
| France | AIR 3407/B |
| Germany | TL 9130-006 |
| Greece | MIL-T-5624, GR JP-4 |
| Italy | AA-M-C-142 |
| Netherlands | MIL-T-5624, GR JP-4 |
| Norway | MIL-T-5624, GR JP-4 |
| Portugal | MIL-T-5624, GR JP-4 |
| Turkey | MIL-T-5624, GR JP-4 |
| United Kingdom | D. Eng R.D. 2454 |
| United States | MIL-T-5624, GR JP-4 |

Kerosene Type Equivalent Fuels

CAUTION

Commercial fuels are commonly made to conform to American Society for Testing and Materials (ASTM) specification D 1655. ASTM specification fuel does not contain anti-icing additives unless specified by bulk purchaser. Therefore, more care than usual must be taken with respect to water contamination and flight conditions when accepting such a fuel.

Commercial kerosene type fuels, freezing point -38°C (-36°F):

| | |
|--------------------|-----------------------------|
| ASTM Specification | D 1655 Type A |
| American | American Jet Fuel Type A |
| Arco | Arcojet A |
| British American | B-A Jet Fuel JP-5 |
| Chevron | Chevron A-50 |
| Cities Service | Citgo A |
| Continental | Conoco Jet 50 |
| Exxon | Exxon A |
| Gulf | Gulf Jet A |
| Mobil | Mobil Jet A |
| Phillips | Philjet A-50 |
| Pure | Purejet Turbine Fuel Type A |
| Shell | Aeroshell Turbine Fuel 640 |
| Standard | Jet A Kerosene |
| Texaco | Texaco Avjet A |
| Union | 76 Turbine Fuel |

Commercial kerosene type fuels, freezing point -48°C (-54°F):

| | |
|--------------------|-------------------------------|
| ASTM Specification | D 1655 Type A-1 |
| Arco | Arcojet A-1 |
| B.P. Trading | BP A.T.K. |
| Cal-Tex | Caltex Jet A-1 |
| Chevron | Chevron A-1 |
| Continental | Conoco Jet 60 |
| Exxon | Exxon A-1 |
| Gulf | Gulf Jet A-1 |
| Mobil | Mobil Jet A-1 |
| Pure | Purejet Turbine Fuel Type A-1 |
| Shell | Aeroshell Turbine Fuel 650 |
| Sinclair | Super Jet A-1 |

Standard Jet A-1 Kerosene
Texaco Avjet A-1
Union 76 Turbine Fuel

Military kerosene type fuels, freezing point -40°C (-40°F):

NATO F-42
France AIR 3404

Military kerosene type fuels, freezing point -50°C (-58°F):

NATO F-40
Australia DEF 207
Belgium BA-PF-6
Canada 3-GP-24
Germany D. Eng. R.D. 2452
Italy AER-M-C-143
Netherlands D. Eng. R.D. 2498
United Kingdom D. Eng. R.D. 2498
United States MIL-T-5624, GR JP-5

Additives

CAUTION

Anti-Icing additive is required at ambient temperatures of 0°C (32°F) and below.

NOTE

The following additives should not be added to fuel MIL-T-5624, Grades JP-4, JP-5, or MIL-T-83133 Grade JP-8 since they are already present in these fuels.

Biocidal additive (methyl cellosolve) should not be added in combination with anti-icing additive.

The following additives, singly or in any combination, additional to those included in the fuel specification, are approved subject to limitation stated.

Anti-Corrosion Additive (DERD2461 and APL2461). Additive may be added in quantities not exceeding 4.0 pounds per 1000 barrels and phosphorus content of 0.06 parts per million.

Anti-Icing and Biocidal Additives (D. Eng. R.D. 2451). Additive (MIL-I-27686 or any direct equivalent) may be added in concentrations not exceeding 0.15 percent by volume.

Biocidal additive (methyl cellosolve). Additive may be added to fuel in concentrations of 0.15 to 0.25 percent by volume. The lower concentrations are intended to be used on a continuous usage or intermittent basis to prevent contamination. The higher concentrations are intended to be used for shock treatment.

CAUTION

Make sure that Biobar JF is the only Biobar product used.

Biocidal Additive (Biobar JF). Additive may be used for shock treatment at a concentration not exceeding 270 parts per million (ppm) (20 ppm Boron) or preventive treatment at a concentration of 135 ppm (10 ppm Boron).

Anti-Static Additive (Shell or Royal Lubricants A.S.A.3). Additive may be added to fuel in concentrations as required to bring conductivity within 200 to 600 pico siemens per meter at point and time of delivery into the aircraft as measured with a conductivity meter.

Engine Oil Requirements

CAUTION

Intermixing of oils of different brands should be avoided if possible. Intermixing of oils of different types is not permitted except in an emergency. If intermixing of oil types becomes necessary, the oil system must be flushed within six hours of operation. (Ref. Honeywell T5317A maintenance manual, 72-00-00, Engine Servicing)

NOTE

When oils approved by Honeywell are not available and other oils must be substituted, consult with:

Honeywell, Inc.
Honeywell Engine
3001 E. Airline
Phoenix AZ 85072-2181
Attention: Manager Military/Helicopter Enterprises

The engine lubrication system oils specified for use in these engines conform to or are similar to Military Specifications MIL-L-7808 or MIL-L-23699. The oils listed in the following paragraphs are approved for engine flight operation.

The following oils are Type I (MIL-L-7808) and are satisfactory for engine starting at ambient temperatures down to -54°C (-65°F):

Brayco 880H
Mobil Jet 184A/201A
Exxon 2389
Royco 808GF
Stauffer Jet I

The following oils are Type II (MIL-L-23699) and are satisfactory for engine starting at ambient temperatures down to -40° C (-40° F):

Castrol 205
Exxon 2380
Mobil Jet Oil II
Shell 500
Stauffer Jet II

Approved Transmission Oils

CAUTION

Dexron II and Dexron III transmission oils are both approved for use in the K-1200 transmission. Intermixing of Dexron II and Dexron III should be avoided if possible.

| Manufacturer | Brand | Designation |
|---------------------------|---------|-----------------------------------------------------|
| American Lubricants, Inc. | Amlube | Automatic transmission fluid (Dexron III) |
| Amoco Corporation | Amoco | Dexron-III ATF |
| Castrol, N.A., Inc. | Castrol | Dexron-III Mercon |
| Castrol, N.A., Inc. | Castrol | Syntec Dexron-III Mercon |
| Chevron U.S.A. Inc. | Chevron | Automatic Transmission Fluid (Dexron III qualified) |
| Citgo Petroleum Corp. | Citgo | Multipurpose ATF Dexron-III Mercon |
| Conoco Inc. | Conoco | Dexron/Mercon III |
| Exxon Company, U.S.A. | Exxon | Superflo AFT D/M (Dexron III qualified) |
| Lyondell Lubricants | Arco | Multi-Purpose ATF (Dexron III qualified) |
| Mobil Oil Corp. | Mobil | Mobil Multi-Purpose ATF (Dexron III qualified) |
| Mobil Oil Corp. | Mobil | Mobil 1 Synthetic ATF (Dexron III qualified) |

Kaman K-1200
Rotorcraft Flight Manual

| Manufacturer | Brand | Designation |
|-----------------------------|--------------|------------------------------------------------|
| Pennzoil Company | Pennzoil | ATF Dexron-III/Mercon |
| Phillips Petroleum Co. | Phillips 66 | ATF Dexron (Dexron III qualified) |
| Quaker State Corp. | Quaker State | Quaker State Dexron (Dexron III qualified) |
| Shell Oil Company | Shell | Donax TG or Donax TX (Dexron III qualified) |
| Sun Co., Inc. | Sunoco | Multi-Purpose ATF (Dexron III qualified) |
| Texaco Lubricants Co. | Havoline | Automatic Transmission Fluid-Mercon/Dexron-III |
| Texaco Lubricants Co. | Texaco | Automatic Transmission Fluid-Mercon/Dexron-III |
| Texas Refinery Corp. | TRC | Dexron III/Mercon |
| Unocal Refining & Marketing | Unocal | Super ATF (Dexron III qualified) |
| Witco Corp. | Kendal | Dexron III/Mercon |

Approved Hydraulic Oils

Arpol Petroleum Co. ARPOLUBE 83282 and FB-001F
 Castrol Inc. Brayco Micronic 882
 Henkel Corporation Emery 2857, 2858, 2859, 2863
 Hexagon Enterprises Inc. Hetrex Hydrol 282
 Huls America Inc. Mobil Aero HFS PQ 3883, PQ 4219, PQ 4268, PQ 4362C, PQ 4401, PQ 4401A, PQ 4401B, PQ 4627, PQ 9400
 Katco Corporation Hatcol 4283, 4284, 4285
 Lubricating Specialties Co. (LSC) FB-001, FB-001A, FB-001B, FB-001C, FB-001D, FB-001E, FB-001F
 NYCO S. A. Hydraunycoil FH2
 Royal Lubricants Co. Royco 782, Aeroshell Fluid 31, Convoy 282, Mobil Aero HFS

Extreme Weather Operation

Abnormal Weather

Maintenance procedures include operation during icing and precipitation, cold weather and arctic operation, and hot weather and desert operation. Engines are designed to operate at outside air temperatures from -54° to 54° C (-65° to 130° F) and up to an altitude of 25,000 feet. When engine is operated under conditions of extreme cold or heat, the following operating precautions shall be observed:

Cold Weather and Arctic Operation

1. Cold weather operation of engine presents no unusual problems if operator is alert to changing ambient temperature and precipitation conditions.
2. Use of anti-icing system will provide protection against icing at power levels above 50 percent maximum continuous power.
3. There is no anti-icing protection below 50 percent maximum continuous power. Operation in icing conditions below this power should be avoided.
4. Anti-icing system must be placed in operation when both following conditions exist: ambient temperature is between 4° and -37° C (40° and -35° F) and it is raining, or free water exists in the air—such as visible fog.
5. Before starting engine, proceed as follows:
 - a. Remove accumulation of snow and ice from air inlet area.

CAUTION

Do not use starter to free a frozen engine.

- b. Manually rotate the compressor rotor to make sure that engine is not frozen.
 - c. Use ground heater units to preheat the engine when the engine is frozen.
 - d. Inspect drains to ensure normal drainage.
 - e. Observe fuel and oil temperature limitations.
 - f. Use normal starting procedures.
6. After engine shutdown, proceed as follows:
 - a. Do not install engine inlet and exhaust covers until engine has cooled.
 - b. During outside storage, make sure that engine inlet and exhaust covers are installed to protect against rain, sleet, snow, or other foreign matter.

Hot Weather and Desert Operation

Hot weather operation of the engine presents no unusual problems. The following maintenance precautions shall be observed:

1. Before starting engine, proceed as follows:
 - a. Check that the engine inlet is free of sand, heavy dust accumulation, and other foreign matter.
 - b. Check all filters more frequently than during normal operation.
 - c. Use normal starting procedures.
2. After engine shutdown, proceed as follows:
 - a. Install engine inlet and exhaust protective covers immediately after engine cools.
 - b. Park aircraft facing into the wind or in sheltered area if possible.

Functional Check Flight Information

Rigging Checklist

1. Rotors rigged with appropriate rigging tools.
2. Blade tracking motors centered.
3. Pedals centered (checked with rigging pin).
4. Pedal trim knob slip-marked with the pedals centered.
5. Check that the pedals remain centered at full forward/aft positions.
6. Verify rudder centered at the upper end of the rudder (only if the rudder was removed).
7. Verify horizontal stabilizer rigging with both full down/up collective, noting the tab positions on the left horizontal stabilizer corresponding to the alignment marks on the left tail boom. **DO NOT FLY THE AIRCRAFT WITHOUT PROPER HORIZONTAL STABILIZER RIGGING. SEE RIGGING TABLE 10-2.**
8. The collective limiter is checked on deck at FLT IDLE. Move the collective through its full range of travel. Collective operation should be smooth with no binding or restrictions noted. (Slightly higher forces may be noted below 70% rotor RPM.) This check should only be performed in calm wind conditions.
9. Check rotor track at FLT IDLE and then at 100%.

10. Set 85–90% N_R and approximately 1/3 “up collective” and make small (one inch or less) pedal inputs to determine apex control. The apex is where the rotor cones appear to intersect in front of the aircraft (it should be near the center of the aircraft). Small pedal movements should result in noticeable apex movement and should be sufficient to move the apex either side of center if it is biased to one side. This demonstrates that adequate pedal authority should be available to control yaw in a hover. If small pedal inputs do not result in apex movement, shut down aircraft and investigate rotor rigging.
11. Rotor RPM beep range should be 85–104 $\pm 1\%$ N_R . The throttle must be in the fly position with the aircraft on deck and the collective full down. Use the BEEP TRIM switch on the collective to set maximum and minimum Rotor RPM. See rigging table.
12. Determine blade adjustments, with tracking motors, at 100% N_R . The tracking motor moves the tracking blade on each rotor. If blades can be tracked with tracking motors, continue the tracking checklist. Otherwise, shutdown and make rotor adjustments as required. Full travel on a tracking motor (no more rotor response to the switch) indicates a 1/2 turn adjustment at the flap rod is required. The direction of movement is determined by the tracking motor. For example, the tracking motor is at full travel with the “UP” position of the switch; option 1 is to raise the tracking blade, and option 2 is to lower the non-tracking blade. In either case, re-center the tracking motor after the adjustment. Small tracking adjustments with the tracking motor will probably be required after this process. See rigging table.

CAUTION

1.5 turns at the flap rod on both blades of one rotor (cone higher/cone lower than other rotor) is equal to full pedal travel (pilot will have insufficient pedal authority for yaw control).

13. Note flat pitch torque at 100% N_R . Approximately 12–16 PSI is normal (low side for warm temperatures and high side for cold temperatures). Torques above 16 PSI or continuous torque fluctuations of more than 0.5 PSI may be indicative of low blade “negative pitch” conditions.
14. Set 98% N_R for takeoff and note any decrease in digital torque during first 2–3 PSI torque increase from flat pitch. A decrease in torque with increasing collective indicates the rotor cones may be set too low. Use pedals, as required for takeoff, to maintain heading.

NOTE

With one or both rotors “out of track,” the “cone matching” will not be accurate.

15. Check “cone matching” (lift of left rotor equal to right rotor with the pedals centered) into the wind with a good rotor track. The aircraft should not turn left or right in a hover with the pedals centered. It may exhibit a tendency to drift left or right a few degrees, but should not continue to turn in the same direction in a “no wind” condition. The pedal trim knob should not be adjusted once the basic control rigging is set. Land and determine the pedal differential (measured at the top of the vertical post for the rudder pedals). See the rigging table to determine appropriate corrections. If the pedal trim knob was used, ensure the rudder pedals are re-centered with the rigging pin prior to continuing.

EXAMPLE

Aircraft tends to turn right in a no-wind hover. The left rotor is producing more thrust than the right. Pilot is holding left pedal for a steady hover. Pushing left pedal lowers the left rotor and raises the right rotor to equalize rotor thrust. Land and determine the pedal differential. Approximately 1/2 inch between the tops of the vertical portion of the pedals with left pedal forward will be used for this example. Option is to lower left rotor or raise right rotor approximately 6–7 holes at the vernier adjustment. If flat pitch torque is low for the temperature condition, raise the low rotor (right rotor in this example) and lower the high rotor for high flat pitch torque indications. When in doubt, lower the high rotor.

16. Verify collective compensation (ENG DROOP RESPONSE). From flat pitch to a hover, rotor RPM should rise 0–1% N_R . In any steady flight condition, set 20 PSI torque and raise power to 40 PSI torque. No change in rotor RPM should be evident.
17. Check rotor track again at 90–100 KIAS and adjust as required with tracking motors.
18. Check for balanced flight at V_{ne} without pedal input; make rudder adjustment if required (shorten rod for more right rudder and lengthen for more left rudder – DO NOT ALLOW RUDDER TO CONTACT AIR-FRAME)
19. Check autorotation RPM. Set autorotation RPM at 75% N_R (–0 to + 5%) at lowest operating altitude (density altitude) and lowest operating gross weight (approximately 5500 lbs.). Changes in operating altitudes may require rotor adjustments to maintain at least 75% N_R during autorotations while still having the capability to produce the maximum amount of torque. If the collective reaches the upper limit prior to reaching an engine limit, then a rotor adjustment is required. Do not let autorotation RPM drop below 75%. See rigging table (Table 10–2).

NOTE

Lowering cones when cones are set at “negative pitch” will decrease, not increase, autorotation N_R .

20. Recheck the “cone matching” in a hover.

WARNING

Autorotation RPM set at greater than 5000 feet may be insufficient at sea level.

NOTE

Typically, a 1/2 turn flap adjustment is required for every 5000 feet change in altitude.

EXAMPLE 1

The helicopter operating altitude is between 2,000 and 4,000 feet DA with a minimum operating weight of 5,575 lbs. The intersection of the 3,000 ft. DA altitude line and 5,575 lbs., gives an auto RPM of 79.3%. Rounding up to the next higher auto RPM (in accordance with note 2 on the autorotation chart in Figure 10-1) gives an auto RPM setting of 80%. The tolerance allowed for this example is from 80 to 85% auto RPM (-0 to +5% of chart value).

EXAMPLE 2

The logging base camp is at sea level (DA) and the highest operating altitude is 10,000 ft DA. In accordance with the above procedures, the rigging should be set to 5,000 ft density altitude. For a minimum operating weight of 5,500 lbs., the auto RPM from the chart should be set at 76%. After adding 5% for a large operating altitude band (in accordance with note 3 on the autorotation chart in Figure 10-1), the auto RPM should be set to 81%. The tolerance, in this case, allows the operator to set between 76% and 81% auto RPM (-0 to +5% of chart value). The high side of the tolerance should be set to ensure that auto RPM stays above 75% at the logging base camp.

Table 10-2. Rigging Table

| Item/Nominal Value | Where | How Much |
|----------------------------------------------------------------------------|-------------------------------------------------------------|-------------------------------------------------------------------------------------------------------------------------------------------------------------------------------------------------------------------------------------------------------------------------------------------------------------|
| Blade Tracking Motors/ Centered | Motorized arm on the tracking motor | Nominal length 1.75" from the housing to the center of the bolt on the bearing |
| Rudder/ Centered on upper end | Control arm at the bottom right side of the rudder | 1/2 turn per 1/2 ball out of trim in level flight at 90-100 KIAS (cw for right rudder and ccw for left) |
| Rotor Track | Flap control rod on low blade | 1/2 turn ccw to raise track 2.5 to 3 inches |
| Rotor Track | Flap control rod on high blade | 1/2 turn cw to lower track 2.5 to 3 inches |
| Rotor "cone Matching"/ (Lift of left rotor | Flap control rods of both blades on one rotor | 1/2 turn for a 1 inch pedal split (ccw to raise cone and cw to lower cone) |
| Rotor "cone Matching"/ (Lift of left rotor equal to right rotor) | Vernier adjustment at the blade root | 13 holes = 1 inch pedal split 9-10 holes = 3/4 inch 6-7 holes = 1/2 inch 3-4 holes = 1/4 inch |
| Autorotation Rpm/ 75% min, see chart in Figure 10-1 | Flap control rods of all blades | 1/2 turn for 3% change in autorotation rpm (ccw to lower rpm and cw to raise rpm) |
| N₁/ Ground idle 50+/-2% Flight idle 70+/-2% | Idle trim screw (N ₁ stops must not be adjusted) | Each 1/2 turn = 7% N ₁ high - turn screw cw N ₁ low - turn screw ccw |
| Rotor Rpm Beep Range/ 85%-104% (±1%) | Beep control rod and crank | Beep range high - shorten 1/2 turn for each 1/2% high Beep range low - lengthen 1/2 turn for each 1/2% low High rpm > 105% - shorten N ₂ Control rod 1/2 turn and lengthen 1-2 serrations Low rpm < 84% - lengthen N ₂ control rod 1/2 turn and shorten 1-2 serrations |

Table 10-2. Rigging Table (Continued)

| Item/Nominal Value | Where | How Much |
|--------------------------------------------------------------------------------------------------------------|-------------------------------------------------------------------------------------------------------------|--------------------------------------------------------------------------------------------------|
| Collective Compensation/ 0 – .5% N ₂ from 20-40 PSI Torque | RPM adjustment control crank and N ₂ control rod | 2 serrations = 1/2% Compensation high – move rod down Compensation low – move rod up |
| Horizontal Stabilizer | Horizontal stabilizer control rod to hori- zontal stabilizer crank | Shorten to move the horizon- tal stabilizer down, lengthen to move up |
| Horizontal Stabilizer Damper/ Full horizontal stabi- lizer travel in less than 2 seconds | With horizontal sta- bilizer control rod and bungee discon- nected from horizon- tal stabilizer | Horizontal stabilizer should fall from full up to full down in less than 2 seconds |

Kaman K-1200
Rotorcraft Flight Manual

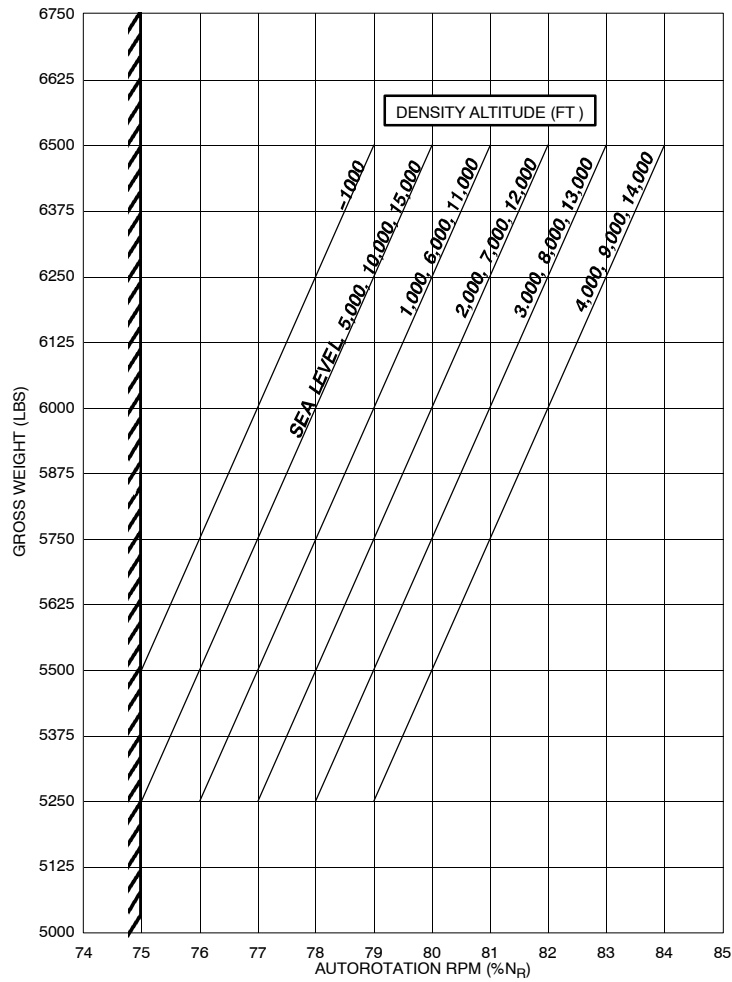

- SEE RIGGING TABLE FOR CHANGING AUTOROTATION RPM.
1. SET AUTOROTATION ROTOR RPM (AUTO RPM) FOR OPERATING ALTITUDES.
 2. ROUND UP TO NEXT HIGHER AUTO RPM FOR ALTITUDE OR WEIGHT INTERPOLATIONS.
 3. IF THERE IS A LARGE DIFFERENCE BETWEEN MINIMUM AND MAXIMUM OPERATING ALTITUDE (>5,000 FT.), DETERMINE AUTO RPM FOR MIDDLE ALTITUDE AND ADD 5% (STAY WITH IN CHART LIMITATIONS OF -0 TO +5%).
 4. AUTO RPM SHOULD NEVER BE LESS THAN 75% AT ANY OPERATING ALTITUDE OR GROSS WEIGHT.
 5. TOLERANCE FOR AUTO RPM SETTINGS FROM THE TABLE IS -0 TO +5%.

Figure 10-1. Autorotation Chart

Slope Landing

Slope landings have been demonstrated up to 10 degrees with the aircraft pointed upslope and downslope. Downslope is the recommended slope landing method. Ground clearance from the tail of the aircraft must be considered during all slope landings.

The static (rotors stopped) rollover angles are listed in Table 10-3.

Table 10-3. Slope Landing Rollover Angles

| Conditions | Turn Over Angle |
|-----------------------------------------------------------------------------------------------|---------------------------------------------------------------------------|
| No Fuel No Pilot 4900 pound aircraft (CG WL = 103) | Aft = 12° (CG Sta = 175) Nose – Main gear line = 26° (CG Sta = 165) |
| Full Fuel (1500 pounds) No Pilot 4900 pound aircraft (CG Sta = 172.4) (CG WL = 88.5) | Aft = 16° Nose – Main gear line = 31.8° |

Operations by Austrian Registered Helicopters

Austrian registered K-1200 helicopters are approved for day VFR operations only. Night VFR is prohibited until the appropriate instruments and equipment required by the airworthiness and/or operating rules are installed, approved, and in operable condition.

Publications Change Request

Every effort has been made to ensure the accuracy of information contained in this manual. If errors are found or if information has been omitted or requires clarification, please direct comments to the following address:

Kaman Aerospace Corporation
P.O. Box 2, Old Windsor Road
Bloomfield, CT 06002-0002
Attention: K-MAX Customer Service

Your name and address: _____

Section/page: _____

Comments: _____
