

PB86-910405



# NATIONAL TRANSPORTATION SAFETY BOARD

WASHINGTON, D.C. 20594

## AIRCRAFT ACCIDENT REPORT

PROVINCETOWN-BOSTON AIRLINES  
FLIGHT 1039  
EMBRAER BANDEIRANTE, EMB-110P1, N96PB  
JACKSONVILLE, FLORIDA  
DECEMBER 6, 1984

NTSB/AAR-86/04

UNITED STATES GOVERNMENT

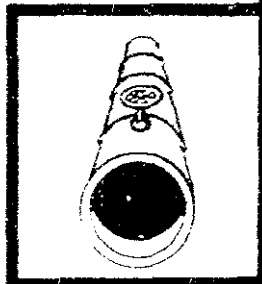
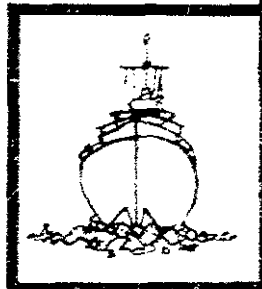
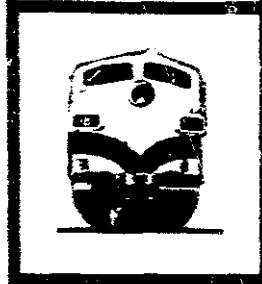
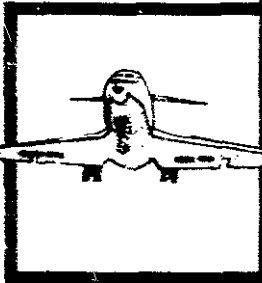

TECHNICAL REPORT DOCUMENTATION PAGE

1. Report No. NTSB/AAR-86/04	2. Government Accession No. PB86-910405	3. Recipient's Catalog No.	
4. Title and Subtitle Aircraft Accident Report-- Provincetown-Boston Airlines Flight 1039, Embraer Bandeirante, EMB-110P1, N96PB, Jacksonville, Florida, December 6, 1984		5. Report Date June 24, 1986	6. Performing Organization Code
		8. Performing Organization Report No.	
7. Author(s)		10. Work Unit No. 4085-B	
9. Performing Organization Name and Address  National Transportation Safety Board Bureau of Accident Investigation Washington, D.C. 20594		11. Contract or Grant No.	
		13. Type of Report and Period Covered  Aircraft Accident Report December 6, 1984	
12. Sponsoring Agency Name and Address  NATIONAL TRANSPORTATION SAFETY BOARD Washington, D. C. 20594		14. Sponsoring Agency Code	
		15. Supplementary Notes	
16. Abstract  Provincetown-Won Airlines Flight 1039, an Embraer Bandeirante, was cleared from the Jacksonville International Airport, Jacksonville, Florida, to Tampa, Florida at 1805 eastern standard time on December 6, 1985, in visual flight conditions. There were 11 passengers and 2 crewmembers aboard the scheduled domestic passenger flight operating under 14 CFR 135. At 1812, flight 1039 was cleared for takeoff, and, at 1813, while over the departure end of the runway and climbing, the crew acknowledged a frequency change. Thirty seconds later, about 1814, the airplane was seen in a steep descent near the extended centerline of the runway.  Flight 1039 struck the ground 7,800 feet beyond the departure end of runway 31 and 85 feet to the northeast (right) of the extended runway centerline in an inverted nose down attitude, after which it caught fire and burned. The airplane was demolished, and all 13 persons aboard were killed. Before ground impact, the horizontal stabilizer, including bulkhead No. 36, had separated from the fuselage. Both elevators and elevator tips, the tail cone assembly, and the aft portion of the ventral fin also had separated in flight.			
17. Key Words Embraer <b>Bandeirante</b> ; in-flight separation; structural failure; elevator control system; nose-down pitch; asymmetrical elevator deflection; full trailing edge up trim tab deflection; runaway trim; uncommanded nose down trim; loss of control; compression loading;		18. Distribution Statement This document is available to the public through the National Technical Information Service, Springfield, Virginia 22161	
19. Security classification (of this report) UNCLASSIFIED	20. Security Classification (of this page) UNCLASSIFIED	21. No. of Pages 102	22. Price

The National Transportation Safety Board determines that the probable cause of this accident was a malfunction of either the elevator control system or the elevator trim system, which resulted in an airplane pitch control problem. The reaction of the flightcrew to correct the pitch control problem overstressed the left elevator control rod, which resulted in asymmetrical elevator deflection and overstress failure of the horizontal stabilizer attachment structure. The Safety Board was not able to determine the precise problem with the pitch control system.

## CONTENTS

<b>SYNOPSIS</b>	<b>.....</b>	<b>1</b>
<b>1.</b>	<b>FACTUAL INFORMATION</b>	<b>1</b>
1.1	History of the Flight	1
1.2	Injuries to Persons	2
1.3	Damage to Airplane	2
1.4	Other Dam	2
1.5	Personnel Information	3
1.6	Airplane Information	3
i.7	Meteorological Information	3
1.8	Aids to Navigation	4
1.9	Communications	4
1.10	Aerodrome Information	4
1.11	Flight Recorders	4
1.12	Wreckage and Impact Information	4
1.12.1	Wreckage Description	4
1.12.2	Fuselage and Wings	4
1.12.3	Separation of Horizontal Stabilizer	5
1.12.4	Separation of Elevators and Elevator Tips	9
1.12.5	Elevator Control System	10
1.12.6	Engines and Propellers	15
1.13	Medical and Pathological Information	16
1.14	Fire	16
1.15	Survival Aspects	16
1.16	Tests and Research	16
1.16.1	Failure Analysis of the Horizontal Stabilizer and Attachment Structures	16
1.16.2	Tests Conducted by the Manufacturer	17
1.16.2.1	Determination of Static Strength, Stiffness, and Frequencies of Horizontal Tail and Rear Fuselage with Bulkhead No. 33 Damage	17
1.16.2.2	Static Tests for Special Conditions at Horizontal Stabilizer Attachment	18
1.16.2.3	Vibration Levels Due to Propeller Unbalance	19
1.16.2.4	Flight Test Load Measurements for Horizontal Stabilizer	19
1.16.3	Elevator Control Rod Breaking Force Conducted by the Manufacturer and the National Bureau of Standards	20
1.17	Other Information	20
1.17.1	Electric Elevator Trim System	20
1.17.2	Manufacturer's Analysis of Pilot Wheel Force to Produce Compression Failure of Left Elevator Control Rod	21
1.17.3	Maximal Static Force Exerted on an Aircraft Control Stick by Seated Males	21
1.17.4	Service History of EMB-110P1 and P2	25
1.17.5	Special Certification Review	26
1.17.6	PBA's EMB-110P1 Takeoff Profile	27
1.17.7	PBA's Training for Rdnaway Trim	27

## CONTENTS (continued)

2.	.....	27
21	<b>The Accident</b> .....	27
2.2	Flightcrew .....	28
2.3	<b>Airplane</b> .....	28
2.4	Engines and Propellers .....	28
25	weather .....	28
2.6	<i>Preexisting</i> Condition of <b>Airplane</b> Structure .....	29
27	Structural and Aeroelastic Consideration .....	30
2.8	Vibratory Load Considerations .....	31
29	Abnormal Stabilizer Loading Caused by Flight Control Malfunctions .....	.31
2.10	Left Control Rod Fracture .....	.32
2.11	<b>Control System Overload</b> .....	32
2.12	Elevator Trim .....	.33
2.13	Sequence of Events Leading to Stabilizer Separation .....	34
2.14	Runaway Trim Theory .....	34
2.15	Seized or Jammed Control System Theory .....	37
2.16	Review of FAA Certification .....	38
2.17	Flight Data and Cockpit Voice Recorders .....	40
3.	<b>CONCLUSIONS</b> .....	43
31	Findings .....	43
32	Probable Cause .....	45
4.	<b>RECOMMENDATIONS</b> .....	45
5.	<b>APPENDIXES</b> .....	49
	Appendix A Investigation and Hearing .....	49
	Appendix B Personnel Information .....	50
	Appendix C Aircraft Information .....	51
	Appendix D Wreckage Diagram .....	52
	Appendix E--Amendments, Airworthiness Directives and Service Bulletins ..	53
	Appendix F--Table 1 .....	97

NATIONAL TRANSPORTATION SAFETY BOARD  
WASHINGTON, D.C. 20594

AIRCRAFT ACCIDENT REPORT

Adopted: June 24, 1986

PROVINCETOWN-BOSTON AIRLINES FLIGHT 1039  
EMBRAER BANDEIRANTE, EMB-110P1, N96PB  
JACKSONVILLE, FLORIDA  
DECEMBER 6, 1984

SYNOPSIS

Provincetown-Boston Airlines Flight 1539, an Embraer Bandeirante, was cleared from the Jacksonville International Airport, Jacksonville, Florida, to Tampa, Florida, at 1805 eastern standard time on December 6, 1985, in visual flight conditions. There were 11 passengers and 2 crewmembers aboard the scheduled domestic passenger flight operating under 14 CFR 135. At 1812, flight 1039 was cleared for takeoff, and, at 1813, while over the departure end of the runway and climbing, the crew acknowledged a frequency change. Thirty seconds later, about 1814, the airplane was seen in a steep descent near the extended centerline of the runway.

Flight 1039 struck the ground 7,800 feet beyond the departure end of runway 31 and 85 feet to the northeast (right) of the extended runway centerline in an inverted nose down attitude, after which it caught fire and burned. The airplane was demolished, and all 13 persons aboard were killed. Before ground impact, the horizontal stabilizer, including bulkhead No. 36, had separated from the fuselage. Both elevators and elevator tips, the tail cone assembly, and the aft portion of the ventral fin also had separated in flight.

The National Transportation Safety Board determines that the probable cause of this accident was a malfunction of either the elevator control system or the elevator trim system, which resulted in an airplane pitch control problem. The reaction of the flightcrew to correct the pitch control problem overstressed the left elevator control rod, which resulted in asymmetrical elevator deflection and overstress failure of the horizontal stabilizer attachment structure. The Safety Board was not able to determine the precise problem with the pitch control system.

1. FACTUAL INFORMATION

11 History of the Flight

On December 6, 1984, N96PB, an Empresa Brasileira de Aeronautica S/A (Embraer) Bandeirante (EMB-110P1) airplane was scheduled for four round trip domestic passenger flights between Tampa and Jacksonville, Florida, operating under 14 CFR 135. N96PB operated as Provincetown-Boston Airlines (PBA) Flight 1054 to Jacksonville and as PBA Flight 1039 to Tampa. One flightcrew operated two morning round trip flights, and a second flightcrew was scheduled to operate two afternoon round trip flights. The captain of the morning flights stated that he performed his predawn aircraft inspection in a well lit ramp at Tampa and that he specifically examined the tail area for loose parts. The morning flightcrew did not report any mechanical problems before turning over the airplane to the afternoon crew.

Witnesses reported that the pilot of the afternoon flight conducted a preflight inspection of the airplane, specifically under the wing and in the tail area before departing Tampa on the first leg of the scheduled afternoon flights at 1640 eastern standard time 1/, 15 minutes late; N96PB arrived in Jacksonville at 1750. Neither ground crew, at Tampa or at Jacksonville, reported any incidents of contact between N96PB and any ground equipment or of any jet blast from taxing aircraft.

At 1805, N96PB, as PBA 1039, was cleared ". . .to Tampa as filed maintain niner thousand squawk 3276 . . ." At 1808, the airplane taxied from the gate at Jacksonville International Airport, Jacksonville, Florida. Eleven passengers and two crewmembers were aboard.

At 1812, PBA 1039 was instructed to ". . .turn left heading two three zero cleared for takeoff runway three one." The captain acknowledged the clearance and flight 1039 began its takeoff. The flightcrew was switched to departure control frequency at 1813, at which time it was over the departure end of runway 31 and, according to witnesses, was still climbing. The captain responded to the frequency change by stating, "ok, so long." Thirty seconds later, the airplane was seen in a steep descent near the extended centerline of runway 31. The airplane crashed about 1814, during darkness at 30° 29' north latitude and 81° 41' west longitude.

The flightcrew of another EMB-110P1, which was on final approach to the airport, saw PBA 1039 as it departed. The flightcrew said that it was nearly dark, and that they identified the airplane as an EMB-110P1 by its lights. The first officer noted ". . . a slightly excessive rate of climb, and it was enough so to make me think in my mind that it was possibly a small jet. . ." Both the captain and the first officer saw the airplane descending straight down. The local controller at Jacksonville air traffic control (ATC) tower, a certificated private pilot, said that the airplane slowly lost altitude while still in a normal climb attitude when it was approximately 3/4 mile beyond the departure end of the runway and, after 6 to 8 seconds, he saw it veer to the right and descend at a steep angle.

**1.2 Injuries to Persons**

<u>Injuries</u>	<u>Crew</u>	<u>Passengers</u>	<u>Others</u>	<u>Total</u>
Fatal	2	11	0	13
Serious	0	0	0	0
Minor/none	0	0	0	0
Total	2	11	0	13

**1.3 Damage to Airplane**

The airplane was demolished by impact forces and postcrash fire.

**1.4 Other Damage**

There was no other damage to property.

---

1/ All times herein are eastern standard, based on the 24-hour clock.

Witnesses reported that the pilot of the afternoon flight conducted a preflight inspection of the airplane, specifically under the wing and in the tail area before departing Tampa on the first leg of the scheduled afternoon flights at 1640 eastern standard time 1/, 15 minutes late; N96PB arrived in Jacksonville at 1750. Neither ground crew, at Tampa or at Jacksonville, reported any incidents of contact between N96PB and any ground equipment or of any jet blast from taxiing aircraft.

At 1805, N96PB, as PBA 1039, was cleared ". . . to Tampa as filed maintain niner thousand squawk 3276 . . ." At 1808, the airplane taxied from the gate at Jacksonville International Airport, Jacksonville, Florida. Eleven passengers and two crewmembers were aboard.

At 1812, PBA 1039 was instructed to ". . . turn left heading two three zero cleared for takeoff runway three one." The captain acknowledged the clearance and flight 1039 began its takeoff. The flightcrew was switched to departure control frequency at 1813, at which time it was over the departure end of runway 31 and, according to witnesses, was still climbing. The captain responded to the frequency change by stating, "ok, so long." Thirty seconds later, the airplane was seen in a steep descent near the extended centerline of runway 31. The airplane crashed about 1814, during darkness at 30° 29' north latitude and 81° 41' west longitude.

The flightcrew of another EMB-110P1, which was on final approach to the airport, saw PBA 1039 as it departed. The flightcrew said that it was nearly dark, and that they identified the airplane as an EMB-110P1 by its lights. The first officer noted ". . . a slightly excessive rate of climb, and it was enough so to make me think in my mind that it was possibly a small jet. . ." Both the captain and the first officer saw the airplane descending straight down. The local controller at Jacksonville air traffic control (ATC) tower, a certificated private pilot, said that the airplane slowly lost altitude while still in a normal climb attitude when it was approximately 3/4 mile beyond the departure end of the runway and, after 6 to 8 seconds, he saw it veer to the right and descend at a steep angle.

**1.2 Injuries to Persons**

<u>Injuries</u>	<u>Crew</u>	<u>Passengers</u>	<u>Others</u>	<u>Total</u>
Fatal	2	11	0	13
Serious	0	0	0	0
Minor/none	0	0	0	0
<b>Total</b>	<b>2</b>	<b>11</b>	<b>0</b>	<b>13</b>

**1.3 Damage to Airplane**

The airplane was demolished by impact forces and postcrash fire.

**14 Other Damage**

There was no other damage to property.

---

1/ All times herein are eastern standard, based on the 24-hour clock.



15 Personnel Information

The flight crew were currently certificated to conduct the flight. (See appendix B)

1.6 Airplane Information

N96PB, an Embraer Bandeirante (EMB-110P1), serial number (S/N) 110365, was owned and operated by Provincetown-Boston Airlines. The EMB-110P1 airplane is a light, twin engine turboprop airplane with a maximum seating capacity of 21, including 19 passengers and 2 pilots. The airplane was designed, manufactured, and certificated to Federal Aviation Administration (FAA) airworthiness standards by Embraer of San Jose dos Campos, Brazil. The airplane's gross weight and center of gravity (c.g.) were within prescribed limits for takeoff at 11,482 pounds and 14.75 percent mean aerodynamic chord (MAC), respectively. (See appendix C.)

Two Pratt and Whitney Aircraft of Canada, Ltd., Model PT6A-34 turboprop engines, S/N PC-E56913 (left) and S/N PC-E56698 (right), were installed; each engine was equipped with a Hartzell propeller, Model HC-B3TN-3C/T1017-88-8R, S/N BU-11553 (left) and S/N BU-10761 (right).

The Brazilian government's certification of the airplane was performed by Centro Tecnico Aeronautica (CTA) under the terms of a bilateral agreement between the United States and Brazil. The FAA validated the CTA certification which included a preliminary type certification meeting with CTA and Embraer officials in 1976 and a 2-week review of CTA certification data in Brazil in August 1978 by FAA specialists. The airplane was initially certified to 14 CFR 23 standards on August 18, 1948. In October 1980, the airplane was certified to Special Federal Aviation Regulations (SFAR) 41 standards, which permitted an increase in maximum takeoff gross weight from 12,500 to 13,007 pounds.

1.7 Meteorological Information

The following surface weather conditions were observed at the Jacksonville International Airport immediately before and after the accident:

Surface aviation, 1748: sky—clear, visibility—7 miles, temperature—47° F, dewpoint—36° F; wind—290° at 10 kts, gusting to 17 kts; altimeter--30.13 Hg.

Local, 1819: sky-clear; visibility—7 miles; temperature—46° F; dewpoint—36° F; wind--310° at 8 kts, gusting to 16 kts; altimeter--30.15 Hg; remarks--aircraft mishap.

A high pressure area centered over eastern Oklahoma, combined with a deep low pressure system located off the Maine coast, created a tight pressure gradient over the eastern United States. Conditions over southern Georgia and northern Florida were characterized by clear skies and moderate west-northwest to northwest winds and cool temperatures. The area weather forecast included flight precautions for turbulence. No SIGMETS, 2/ convective SIGMETS, or AIRMETS 3/ were valid for the Jacksonville area at

2/ Significant meteorological information.

3/ Airman's meteorological information.

the time of the accident. Vertical windshear, computed from the 1800 winds aloft at Waycross, Georgia, 78 miles northwest (319°) of Jacksonville, was 18.0 knots per 1,000 feet between 144 feet above mean sea level (m.s.l.) 4/ and 1,146 feet m.s.l. At 1805, a pilot in the Jacksonville area reported smooth flight below 3,500 feet m.s.l. There were no reports of windshear or turbulence at Jacksonville airport for several hours before the accident.

**B**            **Aids to Navigation**

Not applicable.

**1.9**           **Communications**

There were no known communications difficulties.

**1.10**          **Aerodrome Information**

Jacksonville International Airport is located 9 miles north of Jacksonville, Florida. It is certificated under 14 CFR 139. There are two nonparallel, nonintersecting runways designated as 7/25 and 13/31 and oriented magnetically 074°/254° and 134°/314°. Runway 31, the departure runway for the accident, is 7,700 feet long by 159 feet wide and has a groove", asphalt surface. The airport elevation is 30 feet. An air traffic control tower operated by the FAA is in continuous operation on discrete aircraft frequencies for tower, ground, clearance delivery, and approach/departure. A low level windshear alert system (LLWAS) is installed at the facility.

**1.11**          **Flight Recorders**

Cockpit voice recorders and flight data recorders were not installed and were not required.

**1.12**          **Wreckage and Impact Information**

**1.12.1**        **Wreckage Description**

N96PB struck the ground 7,800 feet beyond the departure end of runway 31 and 85 feet to the northeast (right) of the extended runway centerline in an inverted nose down attitude, after which it caught fire and burned. Before ground impact, the horizontal stabilizer had separated from the fuselage. The horizontal stabilizer was located 6,712 feet beyond the threshold of runway 13 and about 1,100 feet before the main impact area. Both elevators and elevator tips, the tail cone assembly, and the left portion of the ventral fin also had separated in flight and were located along the flightpath between the horizontal stabilizer and the main wreckage. The airplane came to rest on a magnetic heading of 041°. (See appendix D.)

**1.12.2**        **Fuselage and Wings**

The upper fuselage structure, from the main cabin door aft to the baggage door, was subjected to intense fire which consumed a major portion of the cockpit and center fuselage structure. The area between the baggage door and bulkhead No. 33 (the forward attachment point of the horizontal stabilizer) exhibited severe and extensive impact damage with moderate fire damage.

4/ All altitudes appearing herein are m.s.l. unless otherwise stated.

The bottom fuselage, from about the main cabin door into the forward area of the cockpit, exhibited little or no fire damage. In the area of bulkhead No. 33, the left side of the fuselage exhibited an imprint of the forward inboard end of the left horizontal stabilizer and the right side of the fuselage was punctured and scraped down to the ventral fin. The nose gear assembly was extended slightly and the two forward nose gear doors were open partially. Examination of the nose and main gear actuators revealed that the landing gears were in the up position at impact.

The vertical stabilizer remained attached to the fuselage at bulkheads Nos. 29 and 33 by means of fittings bolted to the front and rear spars. The rudder assembly was attached to the vertical stabilizer. Both surfaces were crashed in the forward-to-aft direction. The rudder trim tab was attached to the rudder and was positioned about 90° to the right of neutral. There was no separation between the trim tab actuator in the vertical stabilizer and the rudder trim tab; the control rod was bent to the tight.

A major portion of the left wing, the left aileron, the left wing flap, and the left engine nacelle lower structure were consumed by fire. The right wing and right aileron were not damaged by fire. The right flap was attached and severely damaged by impact, and the inboard end was burned. Both flaps were in the retracted position.

### 1.12.3 Separation of Horizontal Stabilizer

The entire horizontal stabilizer, except the elevators, was in one piece. There were no significant dents or tears along the leading edge or on the upper or lower surfaces.

The horizontal stabilizer is attached to the fuselage at fuselage bulkheads Nos. 33 and 36. (See figure 1.) The forward attachment for the horizontal stabilizer consists of two forward clevis type fittings on the stabilizer front spar which are bolted to the mating male lugs (ears) of a machined fitting on the aft side of fuselage bulkhead No. 33. The rear attachment for the horizontal stabilizer uses four links to connect and vertically offset two clevis type fittings on the aft side of the stabilizer type fittings on fuselage bulkhead No. 36.

The forward attachment fitting of the horizontal stabilizer on N96PB failed at bulkhead No. 33 when the male lugs of the attachment fitting fractured first in shear and then in tensile overstress (See figures 2A, 2B, 3A, 3B, and 4.) The separated male lugs remained bolted to the clevises on the stabilizer. The tail cone, including bulkhead No. 36, and the ventral fin also separated with the stabilizer. The stabilizer rear attachment structure was deformed, but it continued to connect the stabilizer rear spar and the fuselage bulkhead No. 36 fittings.

The stabilizer forward attachment fitting on the aft side of bulkhead No. 33 was deformed with the upper right corner pulled aft and down, tearing the bulkhead web and separating the structural attachments on the forward side of the bulkhead. The left side of the forward attachment fitting remained flushed and attached to the structure forward of the bulkhead, with many fasteners still intact. The deformation indicates that the male lugs on the attachment fitting fractured from overstress forces as the horizontal stabilizer moved aft and twisted clockwise (looking forward) relative to the fuselage.

The examination of the bulkhead No. 33 structure disclosed fretting around some rivet holes in channels which transmit the loads from the upper right corner of the forward attachment fitting into the fuselage structure forward of the bulkhead. The bulkhead web break contained a small preexisting fatigue crack, 5/16 inch long.

# Stabilizer/Fuselage Supports

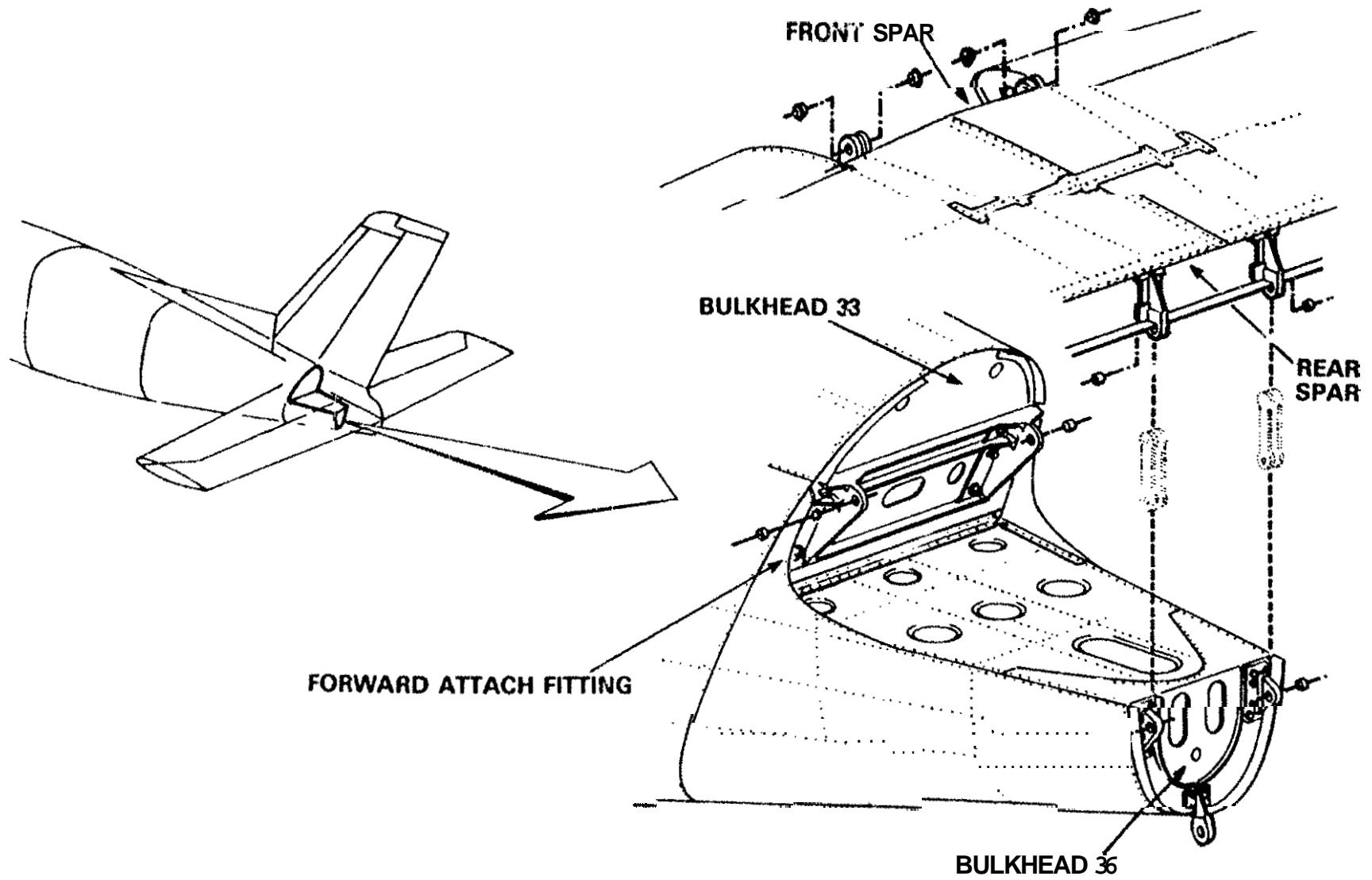

Figure 1.—Bandeirante EMB-110P1 stabilizer/fuselage supports.

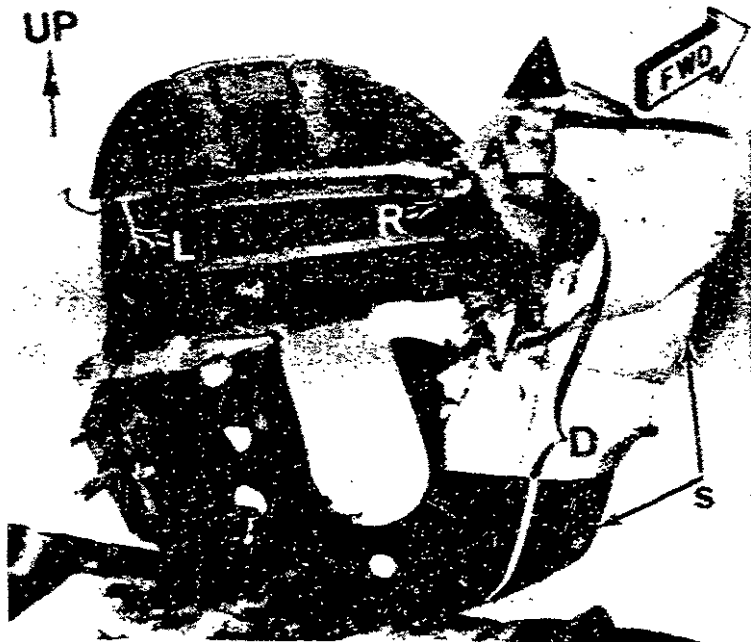

Figure 2A.—View of bulkhead No. 33, looking forward.  
L & R show separation of male clevis ears  
from horizontal stabilizer forward attachment fitting

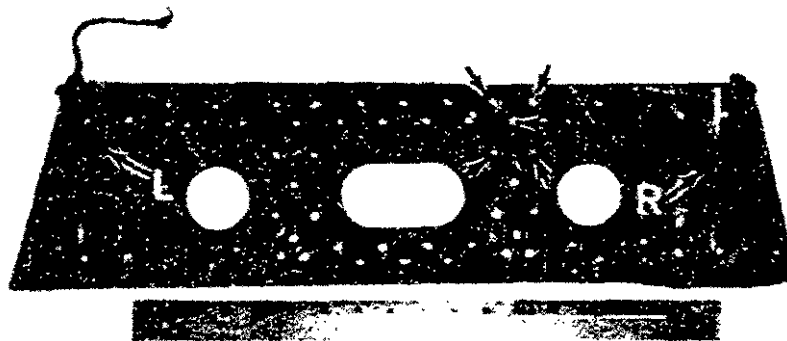

Figure 2B.—Forward attachment fitting removed from bulkhead No. 33.

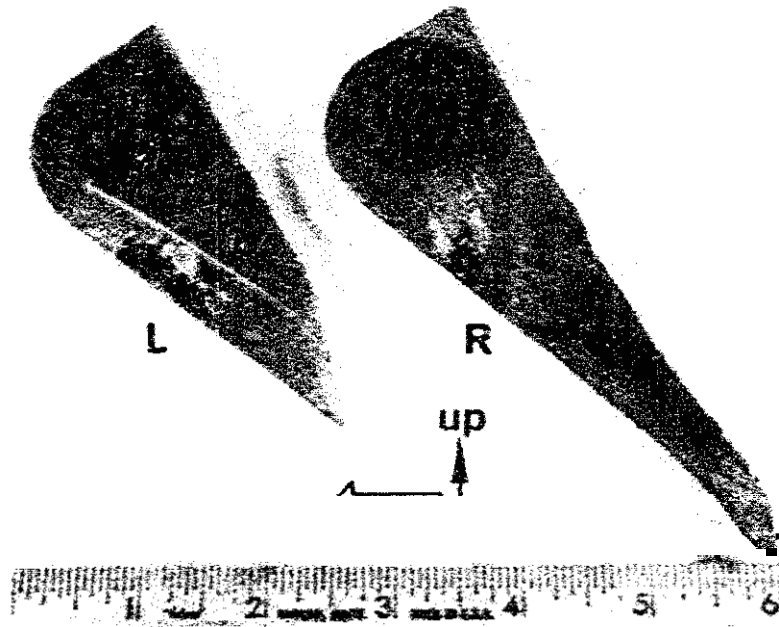

Figure 3A.—Left and right ears of forward attachment fitting which remained attached to horizontal *stabilizer*.

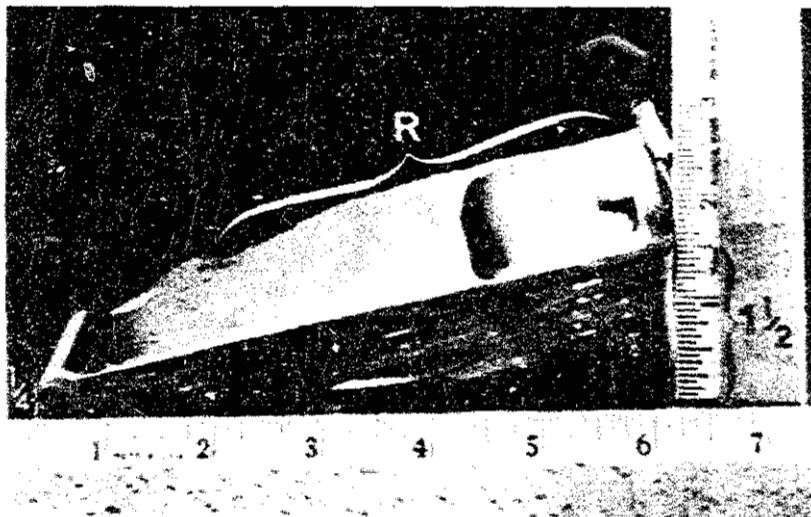

Figure 3B.—View from right side showing twist in forward attachment fitting.



Figure 4.—Rear attachment of horizontal stabilizer at bulkhead No. 36 shows deformation of attachment links.

#### 1.12.4 Separation of Elevators and Elevator Tips

The left and right elevators are not connected to each other except through the flight control system. Each elevator is attached to the horizontal stabilizer at the hinge line by two hinges, one outboard and one about midspan. Each elevator is deflected by a control rod which moves an actuating arm connected to the inboard end of the elevator torque tube. A single, mechanically operated trim tab is on the trailing edge of the left elevator only.

**Bit!** the left and right elevators had separated from the horizontal stabilizer as a result of fractures in the hinge brackets. All of the fractures were typical of overstress separations, except for a small fatigue crack in the right elevator outboard hinge bracket. The examination of the right elevator outboard hinge bracket disclosed that it previously had been removed and replaced.

Both the left and the right elevator actuating arms were attached securely to their respective torque tubes. The portions of both arms that included the up travel stop were broken from the main body of the arms by tension overstress. Heavy contact marks were found on the inboard surfaces where the actuating arms mate with the stabilizer bearing. The main body of the left actuating arm was relatively straight and undeformed. Both the hinge attachment bolt and the main body of the right actuating arm were bent notably with the arm body also displaying a twist relative to its length. When the actuating arm marks were mated to the stabilizer deformation, with the attachment bolt installed within the bearing of the stabilizer, the right torque tube was in

a position as though it had overrotated past the up-stop position by about 90° and the left torque tube was in a rotational position just past the up stop position when the deformation occurred. In both cases, when the deformations were matched, there was an indication that the torque tubes had skewed so that the outboard ends had moved upward.

Both elevator tips had separated from the inboard sections, the fractures having occurred along a plane which included the outboard hinge. A 2-foot 6-inch portion of the right elevator upper outboard skin had peeled from the elevator but had remained attached to the right elevator tip. There was compression buckling on the upper surfaces of both elevators. On the left elevator, the fracture occurred along a line about 70 inches from the leading edge inboard end. On the right elevator, the fracture occurred along two lines, one about 40 inches and one about 88 inches from the leading edge inboard end.

Mass balance weights were installed at the inboard and outboard locations on both the left and right elevators. All of the weights were accounted for and all appeared to have been fastened securely. The presence of weights which differed in color from those originally installed at the time of manufacture indicated that the elevator had been rebalanced since manufacture. The airplane's maintenance records showed that the elevators were balanced on August 27, 1983, in compliance with AD 83-15-10, which became effective on August 9, 1983, and required compliance within 30 days. The balance weight mass distribution was not in total accord with the manufacturer's Structural Repair Manual effective at the time of the accident. The total of the balance weights on both the left and right elevators were below permissible maximums. However, the weights on the outboard station of the right elevator exceeded the 7,850 gram limit for installation at that position by about 325 grams.

#### 1.12.5 Elevator Control System

The elevator control system of the EMB-110P1 airplane is redundant and consists of the captain's and first officer's control columns, which are interconnected, and independent bellcrank-cable-pulley systems on each side of the airplane. (See figure 5.) The movement of either control column will transmit motion through both cable systems to two aft bellcranks mounted on the forward face of fuselage bulkhead No. 33. These aft bellcranks also are interconnected and they transmit motion through the left and right elevator control rods respectively to the elevator actuating arms which rotate the elevators about their stabilizer hinges. The left and right elevator actuating arms are not interconnected.

As a result of the crash, the captain's control column was found detached from the cockpit floor mounting and no elevator control interconnect components were attached to the column. No scoring or impact marks were observed on the control column attachment surfaces at the points where it contacted the forward and aft travel stops. The first officer's control column was found connected to the cockpit floor mounting. It moved freely from the aft travel stop to the forward travel stop. Both travel stops were wired in place, and there was no evidence of impact with the column. The forward elevator control rod was found attached at its correct location between the first officer's control column and the elevator bellcrank. One control column-to-bellcrank cable had not separated from the turnbuckle, and the safety clip was still in place. However, the other control column-to-bellcrank cable appeared to have been cut about 3 feet from the forward bellcrank. The control rod between the captain's and the first officer's elevator bellcranks was severed about 3 inches from the first officer's bellcrank. Both control columns were bent aft and downward about 12 inches below the yoke attachment bolt.



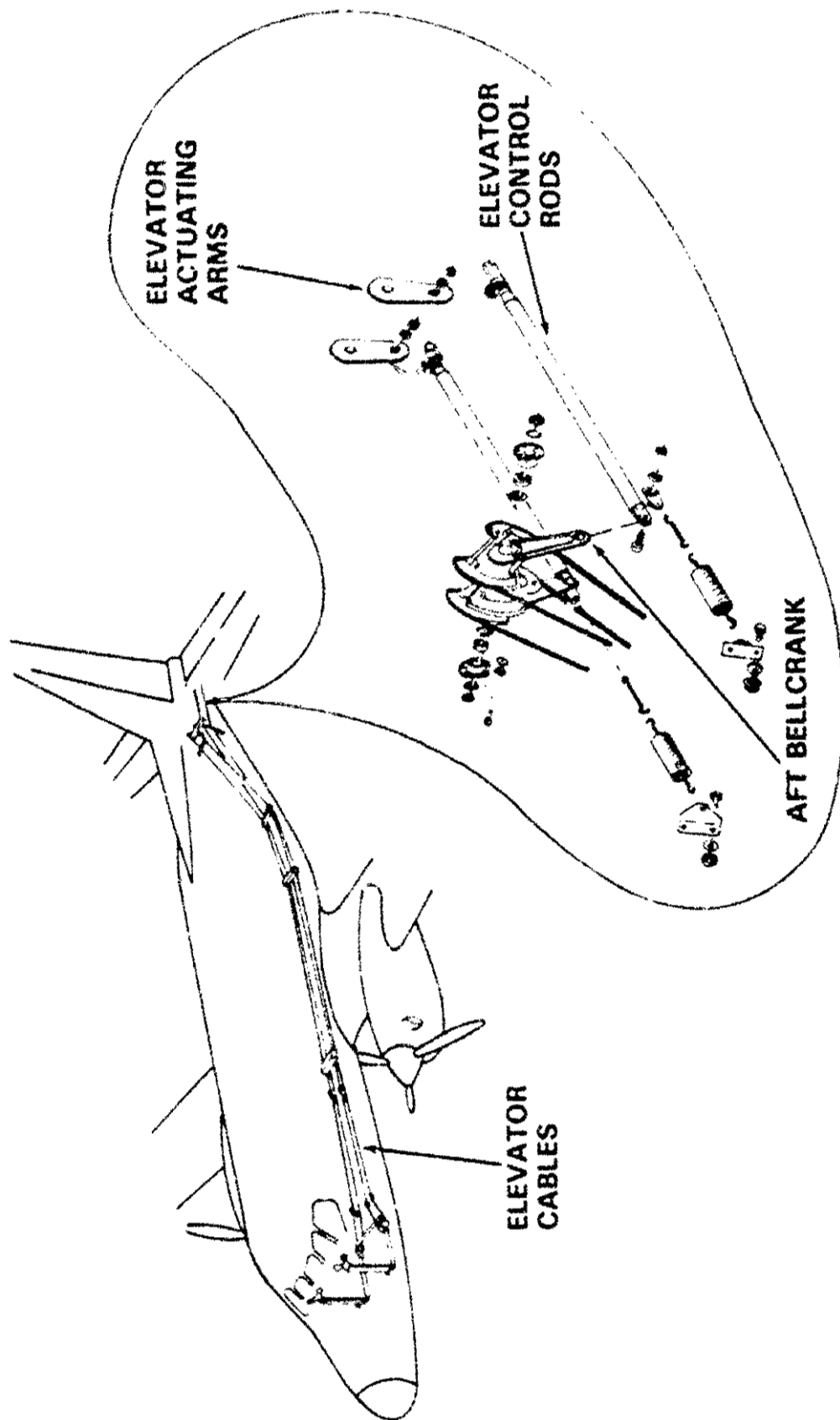

Figure 5.—Pandeirante EMB-110P1 elevator control installation.

All of the elevator control cables between the cockpit controls and the aft bellcranks forward of bulkhead No. 33 were found. There was no evidence that the cables had separated before the accident.

The flight control cables were reexamined in detail at the PBA maintenance facilities in Naples, Florida, on October 13, 1985. About 30 feet of elevator cable, which were attached to the control column bellcranks, showed no evidence of excessive wear, rubbing, or scrape marks. About 90 feet of cable from the aileron or rudder control systems also were examined and showed no evidence of excessive wear, rubbing, or scrape marks.

When the horizontal stabilizer or N96PB separated from the fuselage, both the left and right elevator control rods were deformed and had separated in line with bulkhead No. 34 (11 inches aft of the aft bellcranks.) (See figures 6A and 6B.) The forward portion of each rod remained attached to its respective fuselage mounted bellcrank. The remaining 32 1/2 inches of the aft portion of the right elevator control rod remained attached to the right elevator actuating arm after the separation. However, only 21 1/2 inches of the left elevator control rod was still attached to the left elevator actuating arm. The left elevator control rod was fractured in two places; the aft fracture which occurred near the midpoint of the rod, was a compression buckling failure. The 9-inch section of the left control rod between the two fractures was not recovered. There was an impact mark on the aft side of an upper channel at fuselage bulkhead No 35 which matched the shape of the fracture surface on the aft portion of the left control rod. (See figures 6A and 6B.)

The pitch trim in the EMB-110 is effected by deflection of the single trim tab on the trailing edge of the left elevator. The elevator trim tab deflection is accomplished either mechanically, by rotating a trim wheel located on the pilot's side of the center pedestal (see figure 7), or electrically, by activating switches on either of the control wheels. Both methods effect a linear movement of a threaded cable through a coaxial housing, which in turn extends or retracts the trim tab linear actuator rod through a gear type mechanism. The deflection of the trim tab relative to the elevator surface is directly related to the position of the linear actuator rod. (See figure 8.)

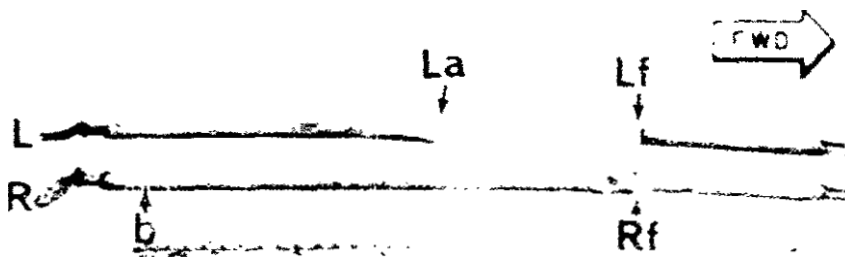

Figure 6A.—Left and right elevator control rods showing symmetrical fractures 11 inches aft of aft bellcranks. Note missing sections of left elevator control rod.



Figure 6B.—View of fracture on aft portion of left elevator control rod and matching impact mark on aft side of upper channel at bulkhead No. 35.

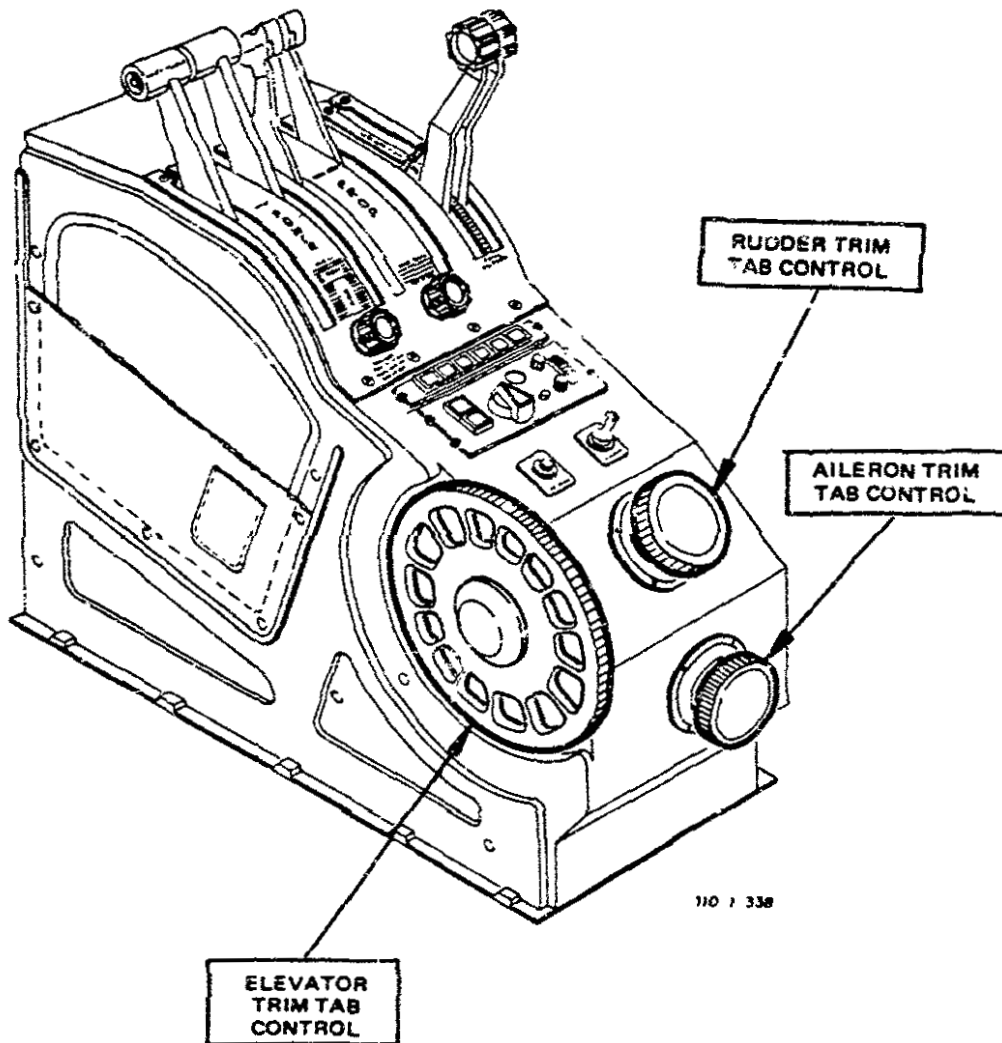

Figure 7.—Trim tab controls.

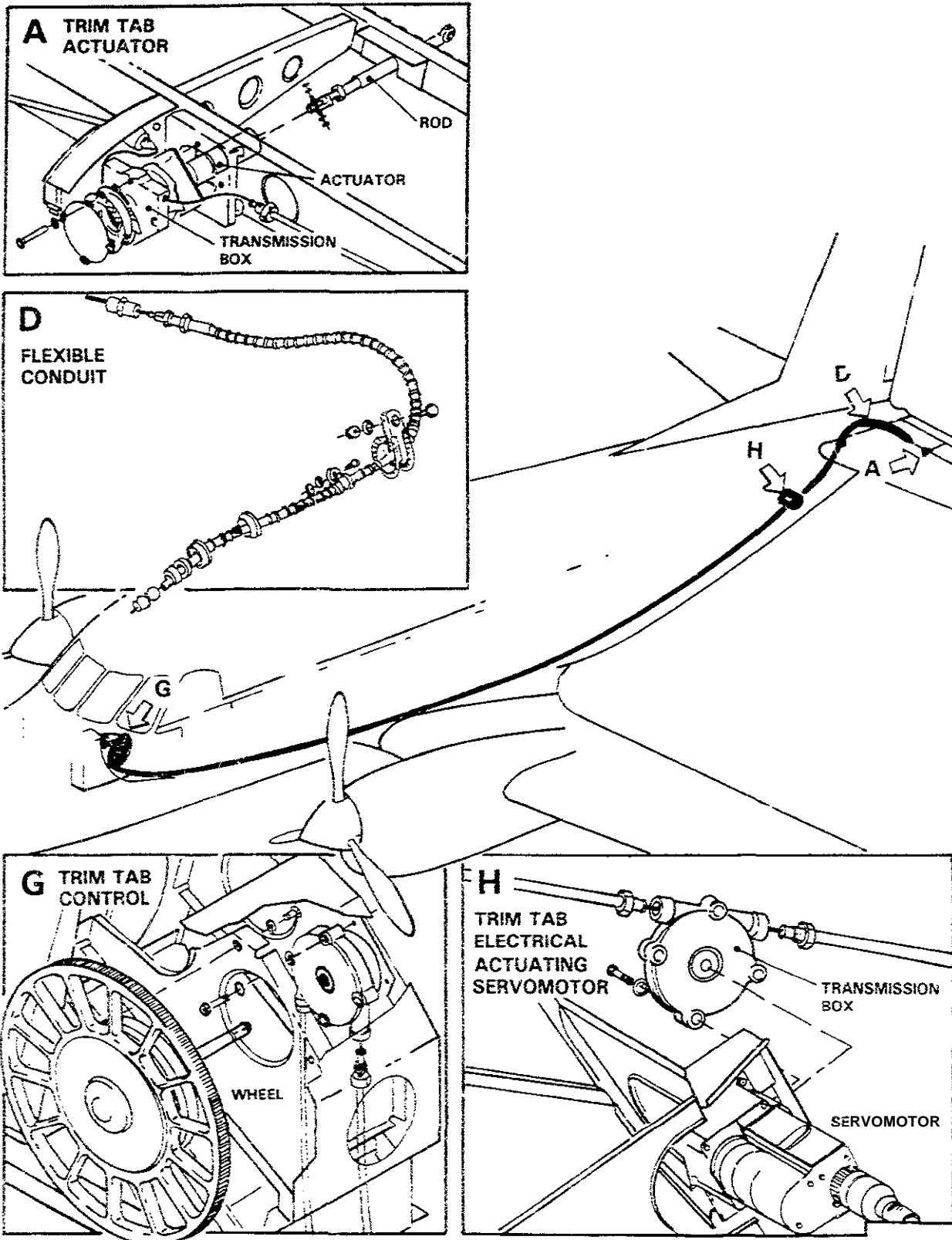

Figure 8.—Bandeirante EMB-110P1 trim tab actuator assembly.

The elevator trim tab **was** attached to the elevator. Although the piano type hinge wire was deformed, measurements of the hinge **and hinge** wire indicated that there was no excessive free play. The trim tab actuator housing remained attached to **the** left elevator spar. The actuator rod was fractured between **the** actuator **and** the rod end which remained attached to the trim tab bellcrank. The overstress bending fracture and deformation of the actuating rod matched the damage **on the** elevator rear spar structure through which the rod passes. The matching damage indicated that the actuator rod was fully extended when it struck the rear spar. The fully extended position of **the trim** tab actuating rod corresponded to a trim tab trailing edge up deflection (full airplane nose down trim).

The elevator trim control wheel on the cockpit pedestal, its associated cable drive gearing, and the threaded cable in the pedestal were exposed to severe heat. The threaded cable was fused to the **drive** gearing by molten metal. The cable runout 5/ was measured and found to correspond to *e* full airplane nose down trim position.

The elevator pitch trim adapter unit cover and connectors were scorched externally. When the cover **was** removed, it was noted that several electronic components were damaged from heat. The trim relay printed circuit board was scorched and the components mounted on the board were heat damaged. The three relays, which routed signals from the trim switches to the trim servo, were too severely damaged for testing.

The pitch trim servo was not complete and the directional control electronics subassembly was found detached from the servo mount. The servo clutch and gear assembly appeared to be undamaged. When about 20 volts dc was applied to the clutch coil, the clutch assembly engaged; when the power was removed, the clutch disengaged. The servo clutch was removed from the servo assembly and the torque was measured and found to be within the specified range. When 28 volts dc was applied to the servo directional control relays, both relays engaged; when the power was removed, both relays disengaged.

#### 1.12.6 Engines and Propellers

Both engines were heavily damaged by the post-impact fire. The left engine was resting on its upper cowl on top of the burned remains of the left wing. The power section had separated from the remainder of the engine. The right engine, which appeared to be undamaged, was found adjacent to and separated from its nacelle near the right wing structure. No penetrations were observed in the engine cases or the exhaust duct of the right engine. Both exhaust ducts were moderately bent and twisted. Both compressor inlet screens were free of debris. Both lower engine cowls were separated from their firewalls and were located adjacent to their respective engines. All cowls were extremely distorted. The engine mounting structures had not separated in flight.

The following items in both engines were undamaged: first and second stage sun and planet gears, the ring gears, the ring gear carriers, and **the propeller oil transfer** sleeves. Both propeller shafts were torsionally sheared at the thin wall area adjacent to the second stage carrier splines. There was no evidence of any inflight turbine blade failures in either engine. All of the centrifugal compressor impeller and vane tips, the adjacent interstage spacers, the impeller vane profiles, and the impeller housings were rotationally rubbed. The impeller vane profiles had contacted the impeller housings so

5/ Cable runout is the cable which accommodates the full linear range of cable travel at the pedestal drive gear.

that *the* entire length of the impeller vanes was rubbed from the inboard *vane tips* through the outboard vane tips. None of the anti-friction bearings installed in either engine displayed *any* obvious distress *or* lack of lubrication. The mounts for both engines were fractured in numerous places. All of the fractures were typical of overstress separation with no evidence of fatigue *or* progressive failures.

The operating components of the fuel control *units*, the fuel pumps, and the overspeed and propeller governors installed on both engines *sustained* no visible impact damage. Some of the components *installed* on the left engine were fire damaged.

Both propellers remained attached to their respective engine reduction gearboxes. *All* three blades from the left propeller were attached to the hub and were nearly complete. One of the blades of the right propeller had separated *from* the hub *but* subsequently was recovered. The pilot tube was compressively elongated, indicating that the blade had separated from high *side* forces. The outboard 1-inch tip of the recovered blade was missing. The other blades of the right propeller remained attached to the hub. *Both* had separated *about* 18 inches outboard of the hub. The outboard section of one of these blades was not recovered. *An* 18 inch section was missing, some of which may have melted. *All* of the blades of the right propeller were damaged by heat and the *ends* were covered with molten aluminum. The end of the blade, the outer *part* of which was not recovered, was bent in the heat damaged *area* as though it had melted *and* sagged of its own weight.

#### 1.13 Medial and Pathological Information

The flightcrew and passengers died from traumatic injuries. Post-mortem fire injuries of varying degrees were noted in *all* cases. The toxicological tests for the captain were negative for alcohol, cocaine, carbon monoxide, and acidic, basic and neutral drugs. The toxicological tests for the first officer were negative for ethyl alcohol and carbon monoxide. The first officer's toxicological samples were not tested for cocaine, acidic, basic, and neutral drugs.

#### 1.14 Fire

The aircraft was subjected to extreme post-impact fire. There was no evidence *of* pre-impact fire.

#### 1.15 Survival Aspects

*This* accident was not survivable due to severe impact forces which exceeded human tolerance.

#### 1.16 Tests and Research

##### 1.16.1 Failure Analysis of the Horizontal Stabilizer and Attachment Structure

Following extensive metallurgical examination of the horizontal stabilizer and its attachment structure from *N96PB*, the Safety Board contracted an independent consultant to perform structural load and flutter *analysis* of the horizontal stabilizer. *EMB-110P1* engineering design data were acquired from the manufacturer. Following a review of the *data*, the Safety Board determined that the manufacturer had made design *Load* calculations in accordance with regulatory standards.

Aerodynamic loads on the horizontal stabilizer were calculated based on a typical EMB-110P1 takeoff and climb profile for the atmospheric conditions that existed at the time of the accident and for the weight and c.g. of N96PB. Also, loads were calculated for 50-foot-per-second gust conditions at maximum cruise speed to determine whether the horizontal stabilizer attachment structure may have been damaged during the flights that preceded the accident flight.

The calculated aerodynamic loads were applied to a finite element mathematical model of the horizontal stabilizer forward attachment fitting and calculations were made of the effects of these loads considering the failures of various fasteners that secure the fitting to bulkhead No. 33 and to the fuselage structure forward of bulkhead No. 33. Based on these calculations, the ultimate load carrying capacity of the attachment fitting with about one-third of its fasteners in the upper right corners of the fitting missing substantially exceeded the aerodynamic loads transferred to the fitting during a normal takeoff and climb. Also, the load carrying capacity of the fitting with all fasteners intact substantially exceeded the load transferred to the fitting during an encounter with a 50-foot-per-second gust at maximum cruise speed.

The flutter analysis of the horizontal stabilizer took into consideration a partial loss of stiffness in the attachment of the stabilizer to bulkhead No. 33 because of failures of fasteners in the attachment fitting and a possible loss of elevator rotational restraint from either a hinge separation or a broken elevator control rod.

A finite element mathematical model of the horizontal stabilizer was developed from engineering data and the stiffness of various connections was calculated from engineering data. Five natural frequencies for the model were calculated which compared favorably to the frequencies identified from engineering data. The computer analysis of the model indicated that a flutter problem did not develop in the speed range investigated (50 to 200 knots) with a broken elevator control, a separated elevator hinge, or reduced stiffness in the bulkhead No. 33 attachment structure. The independent consultant concluded that the horizontal stabilizer on N96PB did not separate from the airplane because of a dynamic flutter problem.

#### **1.16.2 Tests Conducted by the Manufacturer**

The manufacturer performed static load tests to verify the structural capabilities of the EMB-110P1 horizontal tail and the rear fuselage assemblies. An EMB-110P1 fuselage structure from bulkhead No. 26 rearward was mounted on a test stand and static loads were applied to represent a design-critical flight condition; that of a negative gust at the specified design cruising speed with unsymmetrical flight conditions for roll and yaw.

##### **1.16.2.1 Determination of Static Strength, Stiffness, and Frequencies of Horizontal Tail and Rear Fuselage with Bulkhead No. 33 Damage**

Static loads equal to 60 percent, 100 percent, and 150 percent of the defined load condition were first applied to a completely sound structure. Three configurations with progressively more severe failures of the bulkhead No. 33 structure were similarly tested. The most severe condition consisted of the removal of 10 fasteners from the structure on the forward side of bulkhead No. 33 which distributes the loads from the upper right corner of the horizontal stabilizer forward attachment fitting into the fuselage monocoque structure, and a 3-inch crack (sawcut) in the bulkhead web.

There were no failures or permanent deformations to the structure when the ultimate design load was statically applied to the horizontal tail and rear fuselage for any of the configurations tested, including that wherein fasteners were removed and the crack introduced in the bulkhead web.

The displacement of the structure was measured at 24 locations on the horizontal tail and rear fuselage test fixture as loads were applied to determine changes in stiffness and natural frequency for the different failure configurations of the bulkhead No. 33 attachment structure. The measurements showed an insignificant change in the torsional stiffness as a result of the removal of rivets and the introduction of a sawcut at bulkhead No. 33.

#### **1.16.2.2 Static Tests for Special Conditions at Horizontal Stabilizer Attachment**

The manufacturer performed additional static load tests to determine the effects of three special loading conditions on the EMB-IIOP1 horizontal tail and rear fuselage structure from bulkhead 26 rearward. The first loading condition simulated an abrupt, unchecked positive maneuver with asymmetry at the design maneuvering speed. Rivets were removed from the structure on the forward side of bulkhead No. 33, and a 12-inch sawcut was made in the bulkhead web at the upper right corner of the horizontal stabilizer forward attachment fitting. When the limit load condition was applied, there was no further damage.

The second loading condition simulated an asymmetrical air load which would result from asymmetrical deflection of the elevators, a condition possible only if a control system fails. The loading condition for this test was limited to 26 percent of the load which would occur with full antisymmetric deflection of the elevators at the design maneuvering speed of 169 knots. For this test, the sawcut in the upper right corner of the bulkhead No. 33 structure was repaired, fasteners were removed from the structure forward of the upper left corner of the bulkhead, and a 5/16-inch crack was made in the bulkhead web. Additionally five hi-lok fasteners were removed where the center of the horizontal stabilizer forward attachment fitting attaches to the structure on the forward side of bulkhead No. 33. When loads were applied, there was no further failures or permanent deformations during the test.

The third, and most severe, loading condition was the full asymmetric load corresponding to full antisymmetric deflection of the elevators at the design maneuvering speed. The failures at the bulkhead No. 33 attachment were limited to the damage at the upper left corner as described for the second test with the five center located hi-lok fasteners reinstalled. A downward load was applied to the left side, and an upward load was applied to the right side of the horizontal stabilizer.

A complete failure of the stabilizer attachments occurred when the load reached 59.6 percent of the full intended asymmetric load defined above. The load at which failure occurred corresponds to the load which would result from full antisymmetric deflection of the elevators at 141 knots. Lesser elevator deflections combined with higher airspeed could also produce this critical asymmetric load.

The horizontal stabilizer attachment failed when the forward attachment fitting deformed and the male lugs fractured in overstress. The failed fitting was so nearly identical to the fitting from N96PB that no distinctions could be made between the two.



### **1.16.2.3 Vibration Levels Due to Propeller Unbalance**

The manufacturer performed a ground test to determine the vibration levels experienced in the EMB-110P1 horizontal stabilizer structure as a result of an unbalanced Propeller on the right engine. An entire EMB-110P1 airplane was suspended by elastic slings around the wings and fuselage. The spinner section was removed from the right propeller and was replaced by a solid metallic rotating disk which was driven by an electric motor. The imbalance was introduced by drilling various size holes in the disk. There was no attempt to simulate the effects of aerodynamic loads.

To measure vibration levels and calculate stresses, 200 accelerometers were mounted on the airplane's wings, fuselage, and empennage structure. Data were obtained for two propeller speeds, one of which corresponded to a propeller blade resonant frequency. In these tests, the vibration levels of the horizontal stabilizer increased with higher levels of propeller imbalance; the highest vibration levels on the horizontal stabilizer occurred at 100 percent of maximum propeller speed; the highest vibration levels on the elevator and elevator trim tab occurred at 9 percent of maximum propeller speed; and the elevator tips and trim tab experienced the highest vibration level of the horizontal stabilizer.

The manufacturer's acceleration data calculations showed that internal stresses caused by propeller imbalance increased with increasing propeller speed, that the elements around the outboard elevator hinges presented the greatest internal stresses, and that the internal stress levels were greater on the left side of the horizontal stabilizer.

An engineer from the manufacturer, who interpreted the propeller imbalance vibration data during the Safety Board's public hearing, stated that significant variations of stress on the elevator would begin to occur with a missing portion of propeller blade 14 inches long. He further stated that this level of imbalance would produce damage to engine mounts.

### **1.16.2.4 Flight Test Load Measurements for Horizontal Stabilizer**

In response to recommendations of the CTA and FAA Special Certification Review Team, Embraer conducted flight tests in June 1985 to measure the aerodynamic loads on the horizontal stabilizer of an EMB-110P1 airplane for comparison with loads calculated for design. The horizontal stabilizer of the test airplane was instrumented with strain gages to measure shear forces and bending moments at appropriate locations, and measurements were recorded during rectilinear steady climbing flight with flaps and landing gear retracted at speeds between 98 and 150 KIAS. The airplane's weight was about 11,570 pounds and its c.g. was at 14.5 percent MAC. The shear forces and bending moments calculated were small in all flight regimes in comparison to design values.

The manufacturer conducted additional flight tests with the strain gages attached to determine the influence of vibratory loads on fatigue of the horizontal stabilizer. Various flight test profiles were flown, including posttakeoff climb, maximum cruise, maneuvering at 2.5 G, induced buffet at altitude, stall buffet at low altitude, and approach to landing. The manufacturer stated that the analyses of the results indicated that the stress levels from vibratory loads in normal flight regimes are well below the fatigue limits of the materials used in the horizontal stabilizer and that even severe vibratory conditions from buffet and stall produced stress loads below the fatigue strength of the materials at 100 million cycles.

**1.16.3 Elevator Control Rod Breaking Force Conducted by the Manufacturer and the National Bureau of Standards**

Two tests were conducted by the manufacturer to verify the compression strength of the aluminum elevator control rod. A compression load was applied to a complete control rod simulated to the ones on N96PB through the rod end bearings. The load was increased until compression buckling occurred. In the first test, the rod failed at a load of **466 pounds**. In the second test, the rod withstood a load of **507 pounds** before failure.

A third aluminum control rod was tested by the National Bureau of Standards. Again, a compression load was applied through the rod end bearings. Compression buckling occurred at a load of **488 pounds**. In all cases, the failures occurred at the midpoint of the rod and they were similar to the aft fracture of the left control rod on N96PB.

**1.17 Other Information**

**1.17.1 Electric Elevator R i m System**

An electric trim system is an option in the EMB-110P1 and P2. Electrical activation of the Bendix Corporation elevator trim system, which was installed in PBA's EMB-110P1 airplanes at the time of the accident, is accomplished by a reversible d.c. electric motor which drives the trim tab actuating threaded cable in either direction. An electric clutch is installed in series between the electric motor and the cable drive mechanism. Runaway protection is provided by a mechanical separation of the electrical switches which activate the motor and the clutch. A split spring loaded to a neutral toggle switch is installed on both the captain's and the first officer's control wheels so that either pilot can operate the electric trim by depressing both halves of the *split* switch with a single motion of the thumb. The electric circuit is such that the motor switch closes a circuit to apply **28V d.c.** to the motor. The polarity, and thus the direction of operation, depend upon whether the toggle is pushed forward or pulled aft. The clutch switch opens a **28V d.c.** circuit if it is moved in either direction. If the motor switch is operated separately, the motor will operate and the clutch will remain disengaged so that the torque provided by the motor is not transmitted to the trim cable. Conversely, if the clutch switch is operated independently, the clutch will engage, but the motor will not operate.

A warning feature, incorporated into the trim system, provides an aural signal when either a motor or clutch switch is activated independently. The trim system circuit design is such that the switch on the captain's control wheel has priority over the switch on the first officer's control wheel. Further protection against a trim runaway is provided by the mechanical design of the clutch, that is, the amount of torque which the clutch can transmit is limited so that a pilot can stop or override an electrical trim runaway by grasping and exerting about **5 pounds** of force to stop rotation of the mechanical trim wheel located on the left side of the center pedestal between the two pilots.

The airplane manufacturer examined the electrical circuit of the trim system to identify potential failures which would result in an **uncommanded** change in the elevator trim. The identified failures, which would result in the application of **28V d.c.** to the **clockwise** or **counterclockwise** motor operating circuit and the removal of **28V d.c.** from the clutch circuit, were a simultaneous failure of both sections of the captain's control wheel mounted trim switch and a broken connection of the **28V d.c.** wire from

terminal "E" of the captain's trim switch and shorting of the broken off wire to terminal "A" or terminal "D" of the switch. (See figure 9.) This same failure of the first officer's control wheel mounted trim switch also would produce an uncommanded operation of the trim system; however, the operation of the system would be interrupted by any trim selection at the captain's switch. One of PBA's EMB-110P1 captains testified that he did not remember receiving any training for a runaway trim emergency. He did not know the location of the trim circuit breaker.

Safety Board investigators reviewed FAA's service difficulty reports and found no documented occurrences of uncommanded operation of the electrical trim system caused by a switch failure or a broken wire. There have been several occasions wherein one or both halves of a split trim switch has failed to return to the neutral position after the thumb was removed following normal operation of the system. In the known cases, the captain or first officer could stop the trim runaway by moving the switch back to neutral with a thumb.

### **1.17.2 Manufacturer's Analysis of Pilot Wheel Force to Produce Compression Failure of Left Elevator Control Rod**

The EMB-110P1 elevator control system is designed so that a pull force exerted on the captain's or first officer's control wheel to deflect the elevator trailing edge upward against an aerodynamic load (and correspondingly pitch the airplane nose up) results in a compression load on the elevator control rods. The magnitude of the compression load on the left elevator control rod at a given instant from the application by a pilot of a pull force is a function of the factors which define the aerodynamic load on the left elevator; specifically, airspeed, trim tab deflection, and elevator deflection. These factors also can be expressed in terms of the acceleration (load factor) which is produced normal to the airplane longitudinal axis in the resulting pitching maneuver.

In response to a Safety Board request, the airplane manufacturer analyzed the envelope of conditions--pilot force, airspeed, and normal load factor--that will result in a 466-pound compression load in the left elevator control rod. The assumptions for the analysis were that the weight and c.g. location were as they existed during the accident and that the elevator trim tab was fully deflected with the trailing edge upward. The full trailing edge up trim tab would result in the highest compression loading of the left elevator control rod for a given pitch-up maneuver. The plot of pilot force versus airspeed shows the pilot force and normal load factor which would be required at a given airspeed to produce a 466-pound destructive compression load in the left elevator control rod. (See figure 10.)

The analysis shows that a pull force of about 430 pounds would be required at 170 knots to produce a 466-pound compression load in the left elevator control rod and that this pull force would produce a 3 g normal acceleration pitch up maneuver. As airspeed is increased, both the control column pull force required to produce the 466-pound control rod load and the normal acceleration achievable are reduced. At 200 knots, the pilot force needed to produce a 466-pound compression load in the left control rod is about 340 pounds and a normal acceleration slightly higher than 1.5 g will be achieved with that pull force.

### **1.17.3 Maximal Static Force Exerted on an Aircraft Control Stick by Seated Males**

The Human Engineering Guide to Equipment Design sponsored by the Joint Army-Navy-Air Force Steering Committee has published the information shown on

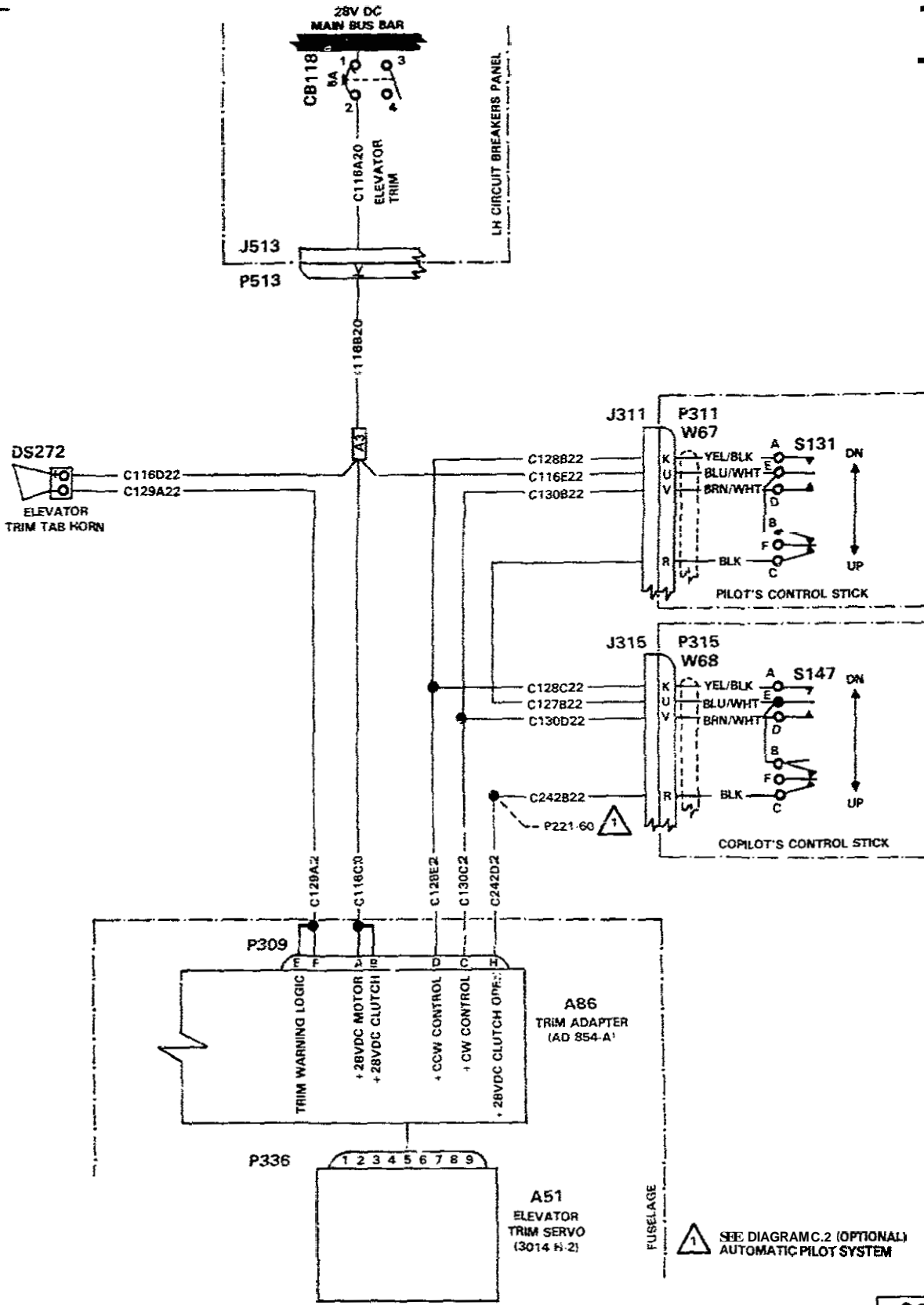

Figure 9.--Elevator trim system wiring diagram.

Tab Deflection: Upwards, Maximum  
W = 31,500 lb & C. of G. = 15% MAC.

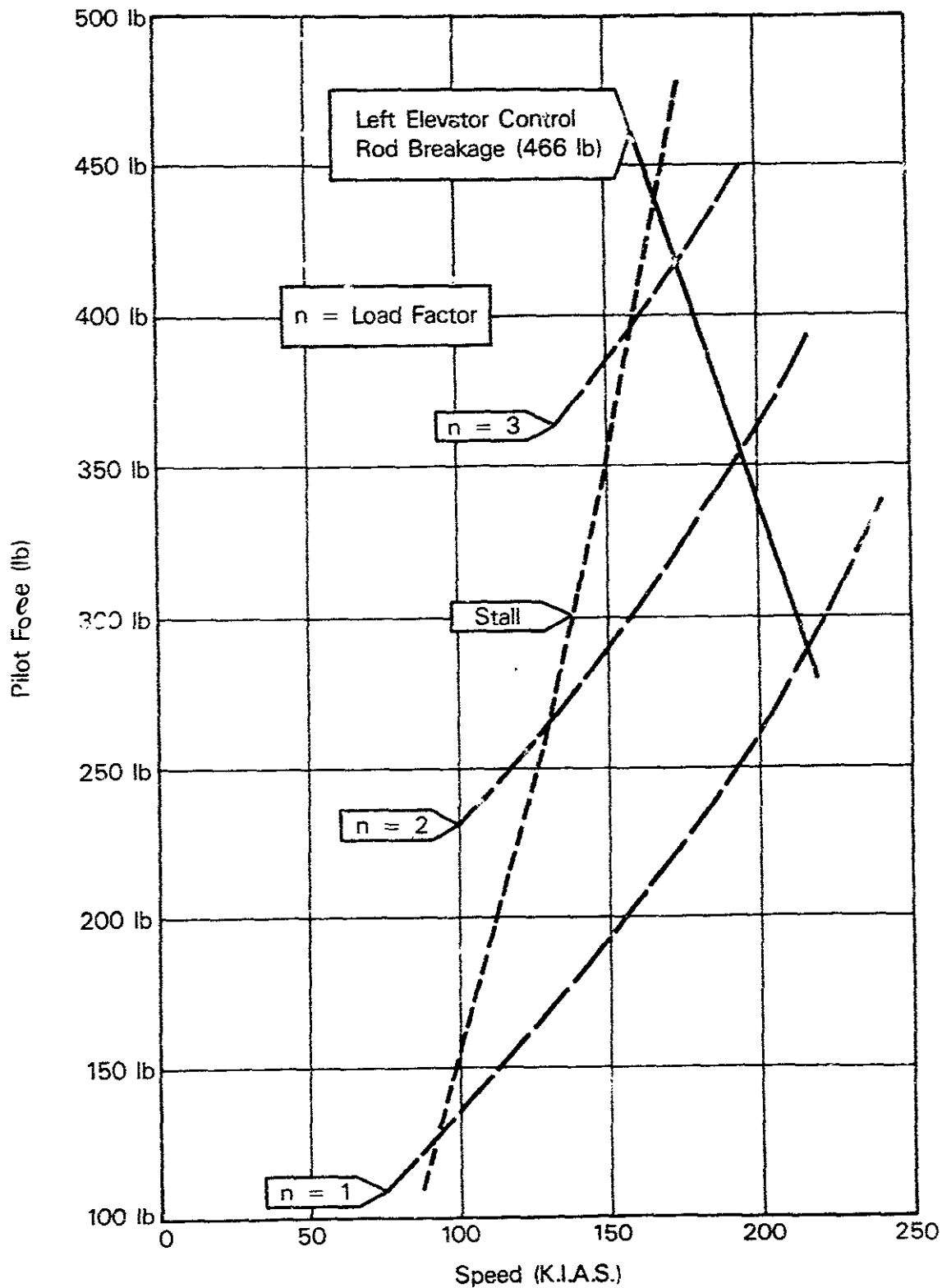

Figure 10.—EMB-110P1 pilot force versus speed.

figure 11. The design criteria for limit control forces specified for compliance with Federal Aviation Regulations Part 23.397(b) for an airplane weighing 13,000 pounds is 238 pounds for an elevator control wheel.

#### **1.17.4 Service History of EMB-110P1 and P2**

At the time of the accident involving N96PB, there were about 450 EMB-110-P1 and P2 airplanes in operation throughout the world, including about 120 in the United States with more than 2,500,000 hours of flight time recorded. During its approximate 11-year service history preceding the crash of N96PB, EMB-110P1 and P2 airplanes had been involved in 11 accidents and 83 reported incidents. One accident and six incidents involved elevator control problems: one of which involved a disconnected elevator control rod, four of which involved either a disconnected or fractured elevator trim tab control rod, and two of which involved a broken trim tab control rod and a broken elevator control rod. None of the accidents or incidents resulted in damage to the horizontal stabilizer attachment structure, although one incident involved damage to an elevator and its outboard hinge.

The service history of the EMB-110P1 and P2 airplanes included problems of vibration in the empennage from propeller slipstream effects. The vibration problems resulted in fastener distress and fatigue cracking in the bulkhead No. 33 structure. In March 1983, the manufacturer issued a service bulletin recommending inspections and modifications of the bulkhead No. 33 area structure to assure the integrity of the horizontal stabilizer attachment structure. An airworthiness directive (AD) was issued by the FAA which required operators to implement the provisions of the service bulletin as of July 27, 1983. (See appendix E)

The maintenance records for N96PB indicated that the airplane was last inspected on September 20, 1984; the inspection complied with AD 82-27-09 and no defects were found. After the accident involving N96PB, the FAA issued an emergency AD that required further inspections of the horizontal stabilizer attachment structure. The Safety Board reviewed the AD and as a result, on January 8, 1985, issued Safety Recommendation A-85-1, which recommended that the FAA:

Issue an airworthiness directive (AD) to require that before further commercial operation in the United States, the horizontal stabilizer attachment of EMB-110P1 and -110P2 model airplanes not previously modified in accordance with AD-83-14-09, Amendment 39-4527, paragraph (d) or (e), be inspected using an improved inspection procedure to enhance detection of loose or sheared rivets, particularly where bulkhead No. 33 transmits the loads from the stabilizer forward attachment to the fuselage monocoque structure. The inspection procedure should require removal of controls as needed for access to riveted joints and application of external loads to detect relative movement between structural members. The AD should require that deficiencies detected during inspection be reported to the FAA and that they be corrected in accordance with an approved procedure before further flight.

The FAA agreed with Safety Recommendation A-85-1 and issued another AD in January 1985. The results of these inspections were reported to the FAA, and they indicated that some airplanes had damage in the bulkhead No. 33 structure more severe than the precrash damage to N96PB.

TABLE 11-98. MAXIMAL STATIC ONE- AND TWO-HANDED FORCES EXERTED ON AN AIRCRAFT CONTROL STICK BY SEATED MALES (N = 20)

Direction of force	Preferred hand		Both hands	
	Means lb	S.D. lb	Means lb	S.D. lb
Forward push.....	167	33.4	199	28.3
Backward pull.....	134	12.7	204	14.3
Lateral push*.....	88	25.0	101	22.4
Lateral pull†.....	63	20.1	88	19.9

Watt (1963).  
 Note: The stick is located 20 in. forward of Seat Reference Point (SRP); see Fig. 11-73.  
 \*Lateral push applied by the palm of either hand against the control handle.  
 †Lateral pull applied by the fingers of either hand against the control handle.

TABLE 11-99. MAXIMAL ONE- AND TWO-HANDED STATIC FORCES EXERTED ON AN AIRCRAFT CONTROL WHEEL BY SEATED MALES (ONE-HANDED, N = 48; TWO-HANDED, N = 15)

Control distance from SRP (in.)*	Wheel rotation (deg.)	A. Push (Percentiles)				B. Pull (Percentiles)			
		Right hand†			Both hands†	Right hand†			Both hands†
		5th	50th	95th	50th	5th	50th	95th	50th
10 3/4	0	52	86	135	147	44	66	102	126
	45 (left)	48	84	149	147	40	67	111	126
	90 (left)	32	67	125	103	23	55	109	98
	45 (right)	40	67	128	147	39	67	97	126
	90 (right)	19	52	112	88	18	43	87	98
13 1/4	90 (left)	32	54	93	88	33	67	120	112
	90 (right)	25	51	83	88	31	60	102	112
15 3/4	0	61	90	155	177	66	94	145	154
	90 (left)	32	59	139	118	42	71	144	140
	90 (right)	32	53	162	132	49	80	130	140
19	0	64	121	235	265	73	106	169	196
	90 (left)	37	68	171	162	60	88	127	154
	90 (right)	33	63	140	162	61	94	149	168
23 1/4	0	105	171	242	265	77	125	182	234
	90 (left)	82	131	211	177	73	117	162	182
	90 (right)	49	117	197	191	74	110	186	190

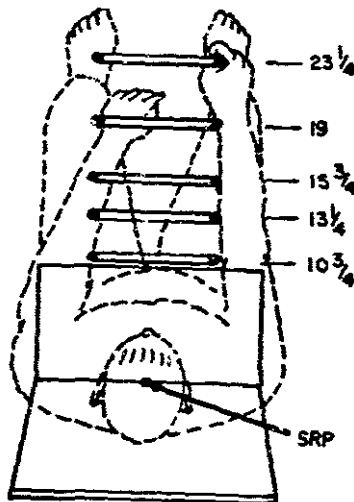

FIGURE 11-74. Maximal one- and two-handed static forces exerted on an aircraft control wheel by seated males.

Figure 11.—Maximal static force exerted on an aircraft control stick by seated males.

The FAA has issued other ADs for the EMB-110P1 flight control system, including one requiring inspections of bearings in the terminals of the flight control rods and trim tab control rods. In 1982, the FAA issued AD-82-27-09, which required inspection of the primary flight control cables to detect frayed and broken wires in the cables; the AD was effective January 10, 1983. From the effective date of AD 82-27-09 through May 28, 1983, there have been 13 service difficulty reports (SDRs) of frayed or worn stainless steel elevator control cables and 17 SDRs of frayed or worn carbon steel elevator control cables. The last report was dated February 1, 1985. The maintenance records for N96PB indicated that the four aft control cables of the elevator control system were replaced with carbon steel control cables on February 2, 1983, and that its primary flight control cables were last inspected on October 8, 1984; no defects were found.

In September 1981, the manufacturer issued SB 110-27-056 which provided for the interconnection of the elevator actuating arms and the replacement of the aluminum elevator control rods with steel control rods. The interconnection of the elevators was to reduce control column vibration caused by vibrations in the horizontal stabilizer. N96PB was not modified in accordance with the SB and the modification was not required. On January 27, 1985, the CTA issued an AD that required Brazilian operators to replace the aluminum elevator control rods with steel control rods. This was due to corrosion found in an aluminum rod that resulted in its fracture during ground operation. In August 1985, the FAA issued AD 85-17-04 requiring the steel control rods and in September 1985, the FAA issued AD 85-18-51 requiring disconnection of the Bendix Corporation electric trim systems installed in EMB-110P1 and P2 models. In August 1985, the FAA issued an NPRM that would require the modification of all EMB-110P1 and P2 airplanes in the United States for the installation of dual trim tab actuating rods in the elevator trim system. As a result of subsequent changes in Embraer's Service Bulletin, an AD has not yet been issued.

#### 1.17.5 Special Certification

As a result of the accident involving N96PB, the CTA and FAA initiated a certification review of the EMB-110P1 and P2 airplane at the manufacturer's facilities in Brazil in December 1984 to determine whether any airworthiness regulatory requirements had been misinterpreted, omitted, or overlooked during the original certification. The review included design loads, static strength, flutter and divergence, service history, maintenance and inspection requirements, and material control. Particular emphasis was placed on requirements related to the empennage structure.

The special certification review team determined that the EMB-110P1 had been certificated properly to U.S. standards during its original certification process, but that further tests and analyses were warranted because of the service history of vibration problems in the empennage. The review team's major recommendations included: (1) a complete flight strain survey of the empennage to determine the significant vibratory loads and their possible effect on fatigue of the structure, (2) a complementary flutter analysis of significant flutter modes to include a 27 Hz mode on the horizontal stabilizer that was not considered in the original analysis, and (3) the incorporation of a fail safe elevator trim tab design, such as the dual trim tab actuating rod design offered by Embraer in SB110-27-068.

In response to the recommendations of the service team, the manufacturer conducted flight tests of the EMB-110P1 to measure flight loads and vibration. Also, a complementary flutter analysis was completed for the empennage for 10 vibration modes measured during ground vibration tests, including the 27 Hz mode. Parametric



studies were performed to account for variations in stiffness, inertia, and aerodynamic loads. The analysis concluded that a flutter problem **did** not exist in the empennage except at speeds above 340 KIAS.

#### **1.17.6 PBB's EMB-110P1 Takeoff Profile**

PBA's Director of Flight Standards provided the Safety Board with a takeoff profile for the **EMB-110P1**, which has been in effect since the airline's recertification.

Before takeoff the appropriate *V* speeds and the minimum required torque area **are determined in** accordance with the Pilot's Operating Handbook (POH). In compliance with the provisions of Special Federal Aviation Regulation (SFAR) 41, the takeoff **flap** configuration is 0°.

Takeoff power is applied smoothly and the airplane is accelerated. At *V1* (the Safety Board determined that *V1* for the accident flight was 96 knots) the airplane is rotated to an attitude which allows it to become airborne at *V2*. (The Safety Board determined that *V2* for the accident flight was 104 knots.) Gear retraction is initiated within 2 seconds after liftoff. After clearing 50 feet, the airspeed is allowed to increase to 130 knots.

Takeoff power is maintained until the airplane reaches 500 feet a.g.l., or circling minimums (470 feet a.g.l. for runway 31 at Jacksonville) whichever is higher. Power then is reduced in accordance with the POH. Climb power is maintained until the airplane reaches cruising altitude and a climb speed of 140 knots is maintained.

#### **1.17.7 PBA's Training for Runaway Trim**

PBA's Director of Flight Standards, who was new to the airline at the time of the accident, **was** unable to determine the manner in which PBA's training addressed runaway trim before the accident involving N96PB. The POH addresses emergency procedures in the event of an undesired pitch trim command, which **are**: (1) if the manual trim wheel is still rotating, stop it and hold it or overpower it, (2) pull the elevator trim circuit breaker (located in the lower forward position on the left side of the cockpit), and (3) use manual trim as required.

The Director of Flight Standards said that the emergency procedures were probably the subject of a classroom discussion.

## **2. ANALYSIS**

### **21 The Accident**

The investigation of the accident clearly disclosed that, **during** the **posttakeoff climb**, the airplane's **elevator tips, elevators, and horizontal stabilizer had** separated causing the airplane to enter uncontrolled flight and to crash. Consequently, the investigation and analysis concentrated substantially on determining the sequence of **and** the reasons for the structural separations. The following hypotheses were considered: structural overload imposed by turbulence; structural failure as the result of pre-existing structural weakness; the onset of a destructive aerodynamic phenomenon as the result of pre-existing damage; the onset of destructive vibration produced by the imbalance of a damaged propeller; and the application of excessive aerodynamic loads as a result of one or more flight control **system** malfunctions.

Two witnesses to the accident observed PBA 1039 accelerate normally on its takeoff roll, lift off normally, and reach about 600 feet above ground level (a.g.l.) near the departure end of the runway. One of the witnesses observed a slightly excessive climb rate and so stated immediately after the accident and subsequently at the public hearing. The other witness noted a normal climb attitude. The recorded radio communications with the control tower revealed a routine acknowledgment of the controller's request to contact departure control. The first separation of airplane structure occurred 25 to 30 seconds later and about 6,000 feet beyond the departure end of runway 31. The witnesses did not see any separations before or during the airplane's descent to the ground because of darkness.

The accident was nonsurvivable because the top of the fuselage collapsed downward to the seat pans with a measured 50 percent reduction in cockpit and cabin volume. This resulted in massive blunt trauma injuries to the occupants that precluded the possibility of survival.

## **2.2 Flightcrew**

The captain and first officer were properly certificated by the FAA to conduct the flight. The Safety Board concluded that the first officer probably was in control of the airplane during the takeoff because the captain made the radio communications. Both pilots were experienced; the captain had approximately 10,000 total flying hours with ratings in several twin engine transport category airplanes, and the first officer had approximately 3,000 total flying hours. Both had sufficient flying time in the EMB-110 to have been very familiar with the airplane's flight characteristics. There was no evidence that either pilot had any adverse medical or psychological conditions that might have affected their performance.

## **2.3 Airplane**

The airplane was certificated, equipped, maintained, and loaded in accordance with existing FAA regulations and company procedures. There was no evidence in the airplane's records to suggest that the flightcrew or company maintenance personnel were aware of any airplane discrepancies before the accident flight which could lead to loss of control or structural failure.

## **2.4 Engines and Propellers**

Both engines, both propellers, and the various powerplant accessories were operating normally until impact. This conclusion is supported by the presence of rotational contact marks and torsional-type impact damage to both engines. Also, both fuel supplies and both fuel metering systems contained fuel and were capable of supplying and metering fuel to the two separate engines. Consequently, the engines were eliminated as a causal factor in the accident.

## **2.5 Weather**

The surface weather observations before and after the accident noted surface winds of 8 to 10 knots with gusts to about 17 knots. Although the area weather forecast included flight precautions for turbulence, there were no indications from weather observations or from witness statements of turbulence sufficient to have affected the structural soundness of the airplane at the time of the accident. Turbulence near the

ground was probably no greater than moderate. Further, there was no evidence that the airplane had encountered significant turbulence **during** the previous flight. Therefore, the Safety Board concludes that weather was not a factor in this accident.

## **2.6 Preexisting Condition of Airplane Structure**

The investigation determined that before takeoff there was no damage to either the stabilizer or to the elevator components sufficient to suggest a preflight collision between the airplane and another vehicle, such as a fuel truck or baggage cart. Further, those persons who observed and serviced the airplane **during** its Jacksonville turn around did not see any vehicle come in contact with **the** airplane. No baggage cart was used. Therefore, the Safety Board concludes that **the** airplane was not subjected to external loads of sufficient magnitude to produce a deformation or failure of the stabilizer attachment structure during a preflight collision, such as contact with a ground vehicle.

The Safety Board determined that the fractures of the male lugs of the forward attachment fitting at bulkhead No. 33 caused the horizontal stabilizer assembly to separate from the fuselage. The deformation and fractures of the attachment fitting indicate that the male lugs fractured first in shear and then in tensile overstress as the horizontal stabilizer moved aft and twisted clockwise (looking forward) relating to the fuselage. Because the loads on the forward attachment fitting are carried into the fuselage monocoque structure by rivets and channels at bulkhead No. 33, and because there was evidence of preexisting damage in this area, the effects of such preexisting damage on the load carrying capability of this structure were analyzed in depth.

The fretting around some of the fastener holes in the channels which transmit the loads from the upper right corner of the forward attachment fitting into the fuselage forward of bulkhead No. 33 indicated that some fasteners had been loose before the final structural failure. Looseness in these attachments would have resulted in a transfer of increased stabilizer loads into the bulkhead No. 33 web. The small preexisting fatigue crack (5/16-inch long) in the bulkhead web supported the contention that loose or sheared rivets had been present before the accident and that the web had been exposed to excess stress.

The susceptibility of the EMB-110P1 and P2 models to fastener distress and web fatigue cracking in the bulkhead No. 33 structure was known before the accident. The knowledge had prompted the manufacturer to issue a service bulletin which described an inspection program to detect loose fasteners and web fatigue cracks. The service bulletin also described an alternative modification to correct the loose fasteners and a procedure to repair the web cracks. The manufacturer's service bulletin was mandated by an FAA airworthiness directive effective July 27, 1983. According to PBA maintenance records, N96PB had been inspected for loose fasteners and bulkhead No. 33 web cracks in September 1984, and no defects were noted. If loose fasteners and a web crack of any length had been detected, a modification to structure would have been required; however, a 5/16-inch crack with no loose fasteners would have been acceptable without a repair to the web. The Safety Board could not determine whether the loose fasteners developed after the September 1984 inspection, or whether the visual inspection methods were inadequate to detect fastener looseness. However, following the accident, other EMB-110P1 and P2 airplanes were reinspected using more positive inspection methods, and some airplanes were found to have similar and even more severe damage in the bulkhead No. 33 attachment structure than the damage believed to have existed on N96PB. Therefore, the condition of the stabilizer forward attachment structure of N96PB

before the accident flight was not unique to that airplane. The Safety Board's concern that loose fasteners in the stabilizer load distribution path could have directly or indirectly contributed to the ultimate structural failure of the forward attachment fitting prompted extensive analyses and tests.

## 2.7 Structural and Aeroelastic Consideration

Two potentially critical effects of pre-existing damage were analyzed: first, the extent to which the static load carrying ability of the structure was reduced and second, the extent to which structural stiffness was reduced thereby affecting the airplane's aeroelastic and vibratory characteristics. The analyses showed that the normal loading on the horizontal stabilizer during a takeoff climb, under the conditions which existed at the time of the accident, would be very small compared to the ultimate structural capacity of the stabilizer forward attachment at bulkhead No. 33. Ample strength remained even when all of the fasteners which may have been loose were totally removed. This analytical finding was confirmed during an actual load test. In the test, a static load equivalent to the maximum stabilizer air load which could be encountered within the airplane's design flight envelope was applied to a stabilizer forward attachment fitting and a test replica of the bulkhead No. 33 structure. The load was applied in a normal symmetrical distribution spanwise across the stabilizer. The tests disclosed that the structure could carry this maximum load without deformation of the forward attachment fitting with all of the fasteners removed in the upper right corner of the fitting and with a 3-inch crack (saw cut) in the bulkhead web. The condition simulated was more severe than that which existed on N96PB. Based on the results of the analyses and tests, the Safety Board concludes that the stabilizer forward attachment structure was fully capable of carrying the ultimate design loads, even with the loose or sheared rivets and a 5/16-inch fatigue crack in the bulkhead No. 33 web.

In the evaluation of the effects of damage on the structural stiffness, the consultants' analysis considered all possible conditions which may have adversely affected the airplane's susceptibility to aerodynamic flutter. Aerodynamic flutter is a phenomenon wherein airstream energy causes deformation of the structure or relative deflections between aerodynamic surfaces which, in turn, excites an oscillation in the aerodynamic surfaces and internal structure. The aerodynamic flutter can be rapidly divergent and can cause forces in primary airplane structure which exceed the maximum design load in a relatively few oscillations. The airspeed at which flutter will occur depends upon the stiffness of the structure and other factors, such as mass distribution. The aeroelastic properties of an airplane are considered during design and certification to the extent necessary to assure that aerodynamic flutter cannot occur within the airspeed range of the airplane. However, aerodynamic flutter can occur at lower airspeeds if stiffness is reduced by looseness in the structure, or if there is excessive free play in the attachment of aerodynamic control surfaces. There was no evidence of excessive free play in the elevator trim tab-to-elevator hinge, in the elevator-to-stabilizer hinge, or in the longitudinal flight control system. However, the Safety Board's examination of the right elevator outboard hinge bracket revealed that this bracket had been removed and replaced during previous maintenance and that the bracket contained a small fatigue crack. The sequence and cause of the overstress failure of the bracket was not apparent.

The Safety Board also considered the spanwise distribution of the balance weights in the elevators of the accident airplane, which was not in total accord with the manufacturer's Structural Repair Manual or with AD 83-15-10, as that spanwise distribution could have affected the structural integrity and the flutter characteristics of the airplane. However, the manufacturer indicated to the Safety Board that the weight distribution of the accident airplane would not have a significant effect on its elevator structure.

The consultant's analysis of flutter characteristics of the empennage considered a reduction in stiffness attributable to loose rivets at bulkhead No. 33, a completely separated elevator hinge, the actual balance weight distribution of N96PB, and a broken elevator control rod. The analysis showed that the airplane would not have encountered an aerodynamic flutter condition in the speed range between 50 and 200 knots. Therefore, the Safety Board concludes that the structural failure was not caused by a divergent aerodynamic flutter.

Although analyses and tests showed that the existence of loose or sheared fasteners in the bulkhead No. 33 structure of N96PB did not affect the ability of the structure to withstand applied static loads or the airplane's aeroelastic characteristics, the Safety Board remains concerned that this condition on other EMB-110P1 and P2 airplanes could lead to progressive fatigue and premature structure failure. The safety Board believes that the FAA should require the horizontal stabilizer attachment structure of EMB-110P1 and P2 airplanes be modified to preclude such damage in accordance with a procedure set forth by the manufacturer. The Safety Board agrees that the tests showed that the stabilizer forward attachment structure at bulkhead No. 33 would carry ultimate stabilizer loads even though weakened by cracks and the removal of fasteners in the bulkhead web. Nevertheless, the Safety Board is concerned that the tests were not sufficient to show conclusively whether the resulting change in load distribution would affect the fatigue life of the redundant load path.

## 2.8 Vibratory Load Considerations

The missing part of one blade of the right propeller prompted concern that the blade might have been damaged before or during takeoff and that a resultant imbalance might have caused structural failure of the horizontal stabilizer. The damage to the other blades of the right propeller and to the blades of the left propeller were not typical of damage which would be expected from a takeoff ground strike. Further, the end of that portion of the blade on the right propeller which remained attached to the hub had melted and sagged under its own weight during exposure to the postcrash fire. Therefore, the Safety Board believes that the missing portion of the blade was consumed in the ground fire. Moreover, the manufacturer's tests in which the horizontal stabilizer and elevator structures were instrumented to measure the vibration loads caused by propeller imbalance disclosed that high loads sufficient to damage the elevators, could be produced only with a 14-inch or longer length of one propeller blade missing. However, the manufacturer stated that a propeller imbalance of this magnitude also would cause destruction of the engine mounting structure. All fractures and deformations of the engine attachment structure on N96PB were typical of damage produced by the extreme forces generated during ground impact and not those that would have been generated by a damaged propeller. Consequently, the Safety Board concludes that there were no destructive vibratory loads imposed on the horizontal stabilizer structure attributable to propeller imbalance.

## 2.9 Abnormal Stabilizer Loading Caused by Flight Control Malfunctions

A significant investigative finding resulted from the tests conducted by the manufacturer when abnormal asymmetrical loads were statically applied to the horizontal stabilizer. Upon application of loads approximating those air loads produced with full antisymmetric elevator deflections at 140 knots (or with lesser elevator deflections at higher speed), the stabilizer forward attachment fitting and the bulkhead No. 33 structure on the test fixture deformed and fractured in a manner nearly identical to the deformation and fractures evident on N96PB. The test provided strong evidence that the

separation of the horizontal stabilizer of N96PB at the stabilizer forward attachment fitting could have been caused by an abnormal asymmetrical air load on the stabilizer. An asymmetrical air load of this magnitude will occur only with antisymmetric elevator deflection, a circumstance which can only follow some other failure or malfunction of the airplane's elevator control system. Therefore, the Board believes the test showed that a failure of the control system preceded the structural separation of the stabilizer.

## **2.10 Left Control Rod Fracture**

Although the left and right elevator actuating arms were not interconnected on N96PB, the two elevators are connected by the aft bellcranks which transmit control system motion to the forward end of the left and right elevator control rods. Consequently, differential deflection of the left and right elevators requires failure of an aft bellcrank, an elevator control rod, or an elevator actuating arm. There was no evidence of failure of either of the aft bellcranks or either of the elevator actuating arms. However, both elevator control rods were fractured.

Based on its examination of the fractures and the relative position of adjacent fuselage structure, the Safety Board concludes that the symmetrically located fractures of the left and right elevator control rods (11 inches aft of the aft bellcrank attachments) occurred when a channel section at fuselage bulkhead No. 34 sliced the rods as the leading edge of the horizontal stabilizer moved downward and aft during its separation from the fuselage. There were no other fractures in the right control rod indicating that the rod was intact until the stabilizer separated. A similar conclusion regarding the left control rod could not be made because that control rod was fractured in two places with a 9-inch intervening section missing.

The aft failure of the left control rod was typical of compression buckling and was initially attributed to impact forces applied when the rod struck the ground and was forced into the earth. However, after determining that differential elevator deflection could explain the horizontal stabilizer forward attachment Separation, the left control rod fracture and the fuselage structure were examined more closely for evidence that the left elevator control rod fractured during flight. The examination disclosed that two facts supported an in-flight fracture: (1) the compression buckling fracture occurred at or very near to the exact midpoint of the control rod (a failure which would be typical of a control system compression induced fracture); and (2) there was an impact mark on the aft side of an upper channel at fuselage bulkhead No. 35 which matched the shape of the fracture surface of the aft position of the left control rod. This impact mark indicated that the rod fractured and the aft portion of the rod had struck the channel before the elevator separated from the stabilizer. Consequently, the Safety Board concludes that the left elevator control rod failed as a result of compression overstress during flight; that this failure, in conjunction with abnormal trim tab deflection, permitted differential deflection of the left and right elevators; and that the resultant asymmetrical loads caused the horizontal stabilizer separation.

## **2.11 Control System Overload**

A load is applied to the elevator control rods whenever a pilot applies a force to either of the control columns to maneuver the airplane in pitch. The load applied under normal conditions is reacted to by the aerodynamic loads on the elevators which are dependent upon the elevator deflection, elevator trim tab position, and airspeed.

During steady state flight, the position of the left elevator trim tab is adjusted to produce an aerodynamic load on the left elevator which **balances the aerodynamic load** on the right elevator. Consequently, in the steady state neutrally trimmed condition, the loading of the left and right elevator control rods will be nearly **equal and** opposite, i.e., one will be in compression and the other in tension, so that the resultant load at the interconnected aft bellcranks will require little or no compensating force at the captain's or first officer's control columns. In an untrimmed flight condition or **during** a pitching maneuver the force exerted on the control column by the captain or first officer will bias the tension or compression loads in both the left and right control rods similarly; however, the effective loads on each elevator control rod can remain unequal because of the influence of the trim tab on the left elevator.

The control system is designed so that a pull force on the captain's or first officer's control column commands an airplane nose up pitching maneuver (trailing edge up elevator deflection) which will result in compression loading of the elevator control rods. Similarly, the pilot pull-force necessary to counter the elevator aerodynamic load associated with airplane nose down trim (elevator trim tab deflected trailing edge up) will result in compression loading of the left elevator control rod only. Consequently, the combination of a commanded airplane nose up pitching maneuver with an airplane nose down trim tab deflection will result in compression forces in both elevator control rods, with the greater force in the left rod.

The manufacturer's analysis of left elevator control rod loads showed that a compression load of about 466 pounds, the load which produced a failure during test by the manufacturer, can be generated only when the trim tab is fully deflected to the trailing edge up position, the airspeed is about 170 knots, and an abnormally high pull force is exerted on their control columns. A control column pull force of about 430 pounds would be required at 170 knots, and this force would normally result in an abrupt airplane nose up pitching maneuver to a normal acceleration force of about 3 g. As the airspeed is increased, the control column pull force necessary to overload the left elevator control rod is reduced, as is the maximum normal acceleration that can be achieved in a pull up maneuver before a control rod fails. If the airspeed reaches 200 knots or higher, the left elevator control rod would fail with a control column pull force of about 300 pounds and the maximum normal acceleration which could be achieved would be about 15 g. Under all conceivable circumstances, the control column pull force required to cause a compression failure of the left elevator control rod would exceed the maximum two-hand pull force of about 200 pounds that can be applied by one male pilot of average strength. Therefore, the Safety Board concludes that both pilots were pulling on their respective control columns when the left elevator control rod failed.

## 2.12 Elevator Trim

The mechanical damage to the elevator trim tab actuator rod and the molten metal fused position of the trim system threaded cable on the cockpit pedestal trim wheel were both consistent with a full trailing edge up deflection of the elevator trim tab. The design of the mechanism is such that the position of the cable would not have changed during the structural separation of the horizontal stabilizer or during the subsequent impact unless commanded by one of the pilots. Because of the difficult control situation which must have existed during and after stabilizer separation, it is improbable that either pilot commanded a trim change. Therefore, the Safety Board concludes that the airplane's elevator trim tab was fully deflected in the trailing edge up position before the structural failure of the stabilizer occurred. Further, the Safety Board concludes that this trim tab position was a key factor in the sequence of events of the accident.

213

### Sequence of Events Leading to Stabilizer Separation

The evidence that the elevator trim tab was deflected to its full trailing edge up position (airplane nose down trim), the left elevator control rod was fractured from compression loading during flight, and the horizontal stabilizer structural attachments were overstressed and separated by asymmetric aerodynamic air loads is all consistent with and supportive of a definitive failure sequence. The aerodynamic loads on the left elevator as the elevator trim tab deflected upward required reactive forces in the control system to prevent the airplane from pitching nose down. The safety Board cannot assess the extent to which pilot forces on the control column, or other forces acting in the elevator flight control system, prevented the airplane from pitching down as the trim tab was initially deflected upward. However, one explanation of the observed damage is that, at some instant during the posttakeoff climb, the airplane pitched suddenly nose down and that both pilots reacted to correct that maneuver with abrupt and high pull forces on their respective control columns. This action produced a compression load in the left elevator control rod which exceeded the design strength of the rod and caused it to fracture. With the restraint of the left control rod removed, the left elevator instantaneously reacted to the aerodynamic load produced by the fully deflected trim tab and moved rapidly trailing edge down. Simultaneously, the fracture of the left control rod caused the high pull forces on the pilot control column to transfer fully to the intact right elevator control rod, which rapidly forced the right elevator to move trailing edge up. The combination of airspeed, which could have reached at last 170 knots during the initial airplane pitch down maneuver, and differential elevator deflection produced high asymmetrical aerodynamic loads on the horizontal stabilizer, which exceeded the strength of the stabilizer forward attachment structure. As a result, the horizontal stabilizer separated from the airplane in a clockwise twisting motion as viewed from the aft looking forward. The Safety Board believes that the elevator tips separated from the elevators and the elevators separated the stabilizer during or immediately after the horizontal stabilizer attachment separated because of the high inertial and aerodynamic loads imposed on the stabilizer assembly in the separation process.

Although a logical sequence of failure following the deflection of the elevator trim tab has been established, the event that caused the elevator trim tab on N96PB to deflect to its full trailing edge up position could not be conclusively established. However, the Safety Board considered the possible explanations for events which may have caused the trim tab deflection and narrowed the possibilities to two: (1) a malfunction in the trim system itself, which may have caused a runaway trim; and (2) a malfunction in the airplane's primary elevator control system, which may have prompted the pilot to intentionally command full airplane nose down trim.

#### 2.14 Runaway Trim Theory

The electrical switches on the captain's and first officer's control wheels and the associated electrical wiring for the elevator trim tab were destroyed by the postcrash fire. Also, the circuitry in the trim adapter box was damaged. Therefore, the pre-crash condition of these components and their possible effect on the functions of the electrical trim system could not be determined.

The service history of the EMB-110P1 and P2 trim system showed no previous occurrences of an electrical trim runaway caused by a circuit defect but showed that there have been multiple occurrences wherein one or both halves of a split trim have stuck (failed to return to neutral) following a trim application. In the known cases of



a stuck trim switch, the pilot **was** able to move **the switch** back to **neutral** with **his thumb**. **Consequently**, the elevator trim **system** in the model has not posed any **significant** problems **to the airplane or its pilots**

The failure mode analysis of the electrical circuit **disclosed one conceivable** way in which the trim could **run** to a full nose **down** position **without** a pilot command and possibly without aural warning. The failure would occur if **a specific wire (28V d.c. motor power)** separated at its terminal **on** either of the pilot's **control wheel switches** and shorted (touched) the adjacent terminal for the **nose down trim selection wire**. This particular anomaly would close the motor circuit and **open** the clutch circuit. **If such a failure** occurred, an **opposite** selection of the split switch to the nose up trim position would have no effect. However, if the failure **occurred on the f i i officer's control wheel**, the captain could **reverse** the runaway by selecting **opposite (airplane nose up) trim** with his switch. If the failure occurred on the switch on **the captain's wheel**, the runaway could **only** be stopped by pulling the system circuit breaker or turning off the **28V d.c. main power**, or, temporarily, by **grasping** the pedestal-mounted **trim wheel**. Only **five pounds** of force **on** the wheel are required to **stop** actuation of the **trim system**. If no action is taken, the left elevator trim **tab** will take about **30** seconds to travel from an approximately neutral trim **position** to the full trailing edge up position.

At 1813:14, when flight **1039** was over the departure end of runway **31**, the captain said, "ok so **long**," in response to a frequency **change**. At 1813:44, just **30 seconds** later, an unidentified voice said, ". . . (unintelligible) . . . like **PBA** went down **off end** of runway." While the captain's last communication, did not indicate that there **was an** emergency in progress, the first officer (the **flying pilot**) **may** have already been experiencing and responding to increasing control pressures on the control column. It seems most likely that in the event of a control problem, the **f i i officer** would alert the captain **as** soon as he became aware of an emergency, and a few **seconds** would have passed before recognition of the problem took place. If conversation **was** necessary to diagnose the problem, request assistance, and provide **instructions** to overcome the condition, then several more seconds may have **passed**. However, there is no way to determine the precise recognition and response time of the **f i i officer**. Because there were no further communications from the captain, he probably became aware of the control problem shortly after **his last** communication and was then too busy **assisting the** first officer to make any further transmissions. Since only **30** seconds elapsed between the last communication from the captain and the crash, the trim **must** have already been in motion toward the nose **down** position, either from deliberate pilot **input** or from a runaway trim. The approved emergency procedure for a runaway trim condition was to overpower the manual trim wheel and to **pull the elevator trim circuit breaker**. Unless **this** procedure had been taught and practiced as an emergency procedure, finding the circuit breaker may have caused further delay during which time the trim would continue to move. However, before the circuit breaker is pulled, either pilot could **stop the** runaway trim temporarily by **grasping** the pedestal mounted trim wheel, **since only 5 pounds** of force on the wheel are required to stop actuation of the trim system.

The **Safety Board** believes that a runaway **trim** resulting from either a stuck switch or a short **of the 28V d.c. motor power wire** to the adjacent nose down **trim** motor terminal at the pilot's control wheel switch may have occurred. **Investigators** could not determine the emphasis given to a runaway trim emergency **in PBA's training program**. Since **this type** of emergency is difficult to demonstrate during flight, the **required training** probably was limited to a classroom discussion of the procedures in the Pilots' Operating Handbook. Testimony of **one PBA EMB-110P1** pilot indicated that he **did not** remember receiving **any training** for a runaway trim emergency and he **did not know** the location **of the circuit breaker**. **Also**, the flightcrew of **N96PB** probably **had never**

experienced an actual electrical runaway trim and the emergency probably had not been demonstrated in an EMB-110P1 airplane. The Safety Board considered this in its analysis of the accident.

During the takeoff and initial climb, the first officer, who was the flying pilot, probably would have exerted a slight pull force on the control column for rotation and lift off and then relaxed the force to establish the desired climb attitude and airspeed. It is probable, especially during relative darkness, that the first officer would have been scanning his instruments as he attempted to establish his climb. It would be normal for him to fine tune the trim setting using his control wheel electric trim switch to relieve the control force as the climb attitude was established, since his left hand would be on the throttle quadrant and the manual trim wheel is on the left side of the center pedestal. If his switch had stuck, the Safety Board believes that it would take little time to note the progressively increasing pull force needed to maintain the target attitude and airspeed and that, without thinking, he would select nose up trim with the control wheel switch to stop the nose down trim runaway. However, if the runaway was the result of an electrical defect in the captain's control wheel switch, the onset of the runaway may not have been immediately apparent to the first officer. If the captain observed any movement of the trim wheel, he probably would think it was the result of deliberate input by the first officer. The time needed for the first officer to recognize the necessity to increase the control column pull force would have depended upon his attentiveness to the instruments or to his visual references. The Safety Board believes that the first officer would have recognized the onset of a problem before the airplane deviated significantly from the desired climb attitude. However, he initially may have been confused when a nose up trim selection on his control wheel switch failed to relieve the nose down tendency of the airplane. It is logical to assume the pilot flying the airplane would have asked the other pilot for assistance to diagnose the problem, to pull the trim circuit breaker, to help with control wheel forces, or to grasp the mechanical trim wheel and stop its motion. The Safety Board is not confident that the procedure of grasping the trim wheel was taught to the pilots, or that they would react immediately to do so. If the trim runaway was not stopped, the control column force required to keep the airplane in a normal 140-knot posttakeoff climb would have increased with full trim tab deflection to about 180 pounds. Although heavy and unusual, this force could have been exerted by an average male pilot using both hands on the control wheel. If the airplane was allowed to pitch nose down, the force required to maintain level flight would have increased rapidly as the airplane accelerated. The distraction of looking for the circuit breaker or the trim wheel may have been sufficient for this to occur. Under such conditions, it is logical to assume that a pilot would have reduced engine power to prevent continued acceleration. However, if the pilot did not take that action, the control forces required to maintain level flight would have increased beyond the capability of one pilot.

To accept runaway trim as the initiating event in this accident, it must be presumed that the pilot flying the airplane permitted it to pitch down and to accelerate until both pilots were aware that an emergency pull up with maximum control column forces was necessary. Even if the pilots had not been trained for a runaway trim emergency, the Safety Board believes that the only action required to prevent resultant loss of control is basic airmanship and the recognition of an out-of-trim condition would be immediate, since the pilot would sense the behavior control forces. However, the diagnosis of the problem and the corrective action would take time to resolve, especially if the pilot had not been trained to grab the trim wheel and pull the circuit breaker. A natural reaction would be to exert control forces and to reduce power as needed to maintain level flight without permitting the airspeed to increase significantly. Consequently, although the Safety Board cannot exclude the possibility that the full airplane nose down elevator trim was caused by an electrical defect in the pilot's control

wheel trim switch, we believe that a flightcrew with the experience of the accident flightcrew probably should have been able to overcome such a condition **without** losing control of the airplane to the extent that a high positive load factor maneuver would **be** needed for recovery. However, the lack of training for such an **occurrence** would have permitted the situation to get out of control. Therefore, the Safety Board believes that hands on training for a **runaway** trim emergency should **be** given in the **airplane** as a **part** of cockpit orientation. The Board recognizes the difficulties involved in in-flight simulation of a runaway trim condition.

The Safety Board believes that a flightcrew that has received *training* for a runaway trim emergency, which includes a simulator demonstration of the control forces required to prevent the airplane from accelerating out of control and the actions required to stop the runaway, would be likely to react more quickly to the emergency **than** an untrained crew. Therefore, the Safety Board supports the efforts of the Regional Airline Association to **promote** the development and use of training devices acceptable to the FAA for the class of airplanes used in its operations.

## 2.15 Seized Or Jammed Control System Theory

The other possible explanation for the accident airplane's full nose down elevator trim tab deflection is that the pilot flying the N96PB intentionally commanded the nose down trim **in an** attempt to correct or compensate for an elevator control system malfunction. The first officer of a landing airplane who observed flight 1039 takeoff stated that he believed the flight's initial climb rate was slightly excessive for an EMB-110P1. This observation is contrary to the climb rate which would be expected in the case of a nose down trim runaway and leads to a postulation that the pilot of N96PB encountered **some** difficulty in lowering the airplane's pitch attitude after takeoff.

If the elevator control system on N96PB had jammed or seized during or after the takeoff rotation with the elevators in a nose up pitch attitude, the difficulty in lowering the nose of the airplane to a normal climb attitude would have become more apparent as the airspeed increased. A pilot's reflexive action to correct **an** excessive nose-up pitch attitude would have been to exert a push force on the control column and to command airplane nose down trim. The trailing edge up deflection of the elevator trim tab (nose down trim) would normally produce an airload to deflect the elevator trailing edge down and to pitch the airplane nose **down**. However, if the control system had remained seized or jammed and the elevator position had remained fixed, the elevator trim tab deflection would have produced **an** effect opposite to that desired, **and** the nose of the airplane would have continued to rise, prompting the pilot(s) to push even more forcefully on the control column. Under such circumstances, if the combined forces within the control system produced by the elevator trim tab airloads, acting as a moment at the elevator hinge, and by the push force on the control column, had reached a threshold sufficient to relieve the control system seizure **or** jam, the suddenly freed elevators, **would** have moved trailing edge down, and the airplane would have pitched abruptly nose down. A pilot's normal and reflexive action to a : abrupt nose down pitch change at low altitude **would** be to rapidly reverse the control column forces **and** pull back on the control yoke. Consequently, it **is** possible that the sudden pull forces exerted by the pilot(s) would have been sufficient to have failed the left elevator control rod. It **is** also possible that the pilots' pull forces might have caused the control system to seize **or** jam again, so that the available pitching moment **was** limited to the extent that *the* airplanes descending flightpath could not **be** corrected. The pilots might then have pulled back on the control yoke to their maximum capability **in an** attempt to prevent impact with the ground. If the seizure or jam was again relieved, destructive dynamic forces **would** have been imposed on the left elevator control rod.

There was **no** tangible evidence from the examination of the wreckage of a seized or jammed control system, nor have there been any **known** occurrences of such problems in the EMB-110P1 and P2 service history. However, there have been some SDRs in which stainless steel elevator cables have become worn where they **pass** through fairlead blocks near the midsection of the forward-to-aft cable run, an event which can lead to seizure of a cable within a fairlead block. The identification of this problem prompted the manufacturer to issue a service bulletin that recommended the replacement of stainless steel elevator control cables with harder carbon steel cables, which are more resistant to wear. The **aft** cables were replaced on N96PB in February 1983, and the cables were inspected in October 1984, with no defects noted. Notwithstanding these maintenance actions, it is possible that a worn cable seized within a fairlead block during the takeoff rotation, particularly **since** problems have been reported with the carbon steel cables. Also, a control system jam could have been caused by a foreign object interfering with a cable pulley or by a control column, or by a seized right elevator hinge bearing. Any of these conditions could have resulted in an elevator control system seizure or jam which could have been relieved only by high control system forces or by a momentary reversal of the force applied to the control yoke.

In summary, the Safety Board believes that a control system seizure or jam, followed by the foregoing sequence of events would explain this accident and probably is more easily understood than a runaway trim occurrence, because the pilots should have been able to control a runaway trim by applying the required pull force on the control wheel to prevent loss of control even though they might not have been able to immediately diagnose the nature of the emergency. Further, it is not likely that the pilots could have taken actions to prevent the accident if the control system had seized or jammed. The inability of the Safety Board to determine conclusively the initial event which resulted in the full trailing edge up deflection of the elevator trim tab precluded the Board from citing either runaway trim or E jammed control as causal. Consequently, identification of factors which could have **seen significant** to the accident cause or contributing cause was not possible. For example, if the initial event was an electrical trim runaway, the Safety Board would focus greater attention on flightcrew performance and operator pilot training; and if the initial event was a seized or jammed control system, the accident may have occurred with flawless pilot performance. In the latter case, the Safety Board would focus more attention on the airplane design, the operator's maintenance and inspection program, and/or the FAA's surveillance of those programs, even though the Safety Board's investigation did not find significant tangible evidence of deficiencies in any of the areas.

## **2.16**      Review of FAA Certification

An in-flight structure failure of any airplane in the absence of circumstances to explain an obvious overstress condition always prompts concern about the airplane's original design and certification criteria. In this case, the particular areas of interest include the **design** load criteria, aerodynamic flutter characteristics, elevator control system strength, and elevator trim system runaway protection. The Safety Board reviewed the certification procedures and concluded that the FAA's original U.S. certification of the EMB-110 was procedurally proper and in accordance with the provision for the certification of a product that is manufactured in a foreign country. The Special Certification Review initiated by the FAA and the CTA following the accident provided further assurance that the original certification of the airplane was accomplished in accordance with applicable regulations.

The Special Certification Review team evaluated the design load criteria and the aerodynamic flutter characteristic<sup>3</sup> of the airplane and found only minor discrepancies in the analytical and test data used initially to show compliance with the FARs. The Safety Board concludes that the discrepancies were not relevant to the cause of this accident. Neither the design criteria nor the certification requirements included a structural design load consideration for antisymmetric aerodynamic loading of the horizontal stabilizer. The Safety Board agrees that because it is not possible to achieve such a loading condition absent other failures which could render the airplane uncontrollable, an antisymmetric loading condition is not a reasonable design consideration.

In their evaluation of flutter characteristics, the special certification review team noted that the airplane, although in compliance with the U.S. certification basis specified in the appropriate section of the FAR's effective in September 1969 and during original certification, was not in compliance with a recent amendment to the FAR which requires that the airplane be shown to be free from flutter following the failure of a trim tab actuating rod. The service history of the EMB-110P1 and P2 revealed one accident and five incidents wherein an elevator trim tab actuating rod had failed or become disconnected and the free tab had caused excessive vibration of the airplane. In this accident, the evidence is conclusive that the elevator trim tab actuating rod was intact, connected, and not a factor in the structural failure. Further, there was no free play in the tab hinge.

The Special Certification Review Report did not specifically address the certification of the airplane as it related to control system strength or to trim system runaway protection. The Safety Board is concerned since the accident that a failure of a primary part of the airplane's flight control system could be achieved by a pilot-applied load, notwithstanding that the load was applied by two pilots, both pulling at near maximum strength on their control wheels. Although the total load resulting from the efforts of both pilots far exceeds the reacting aerodynamic loads achievable within the airplane's flight envelope, such a load might be required to overcome a jammed flight control condition. The FAR addressing flight control system strength has remained unchanged since the certification of the EMB-110P1 and P2 and specifies that the flight control system strength be designed to withstand the maximum effort of the pilot applied to the system; this maximum effort is defined as a 238-pound force applied to the (elevator; control wheel. The strength of the EMB-110P1 and P2 flight control systems, including the elevator control rods far exceeded this requirement. In further consideration of the design strength of the systems, the load applied to the aft bell crank is normally divided between the left and right elevator control rods, each of which is capable of withstanding the maximum control system force which can be applied by one pilot. Furthermore, the left and right elevator control rods are considered to be redundant because an in-flight failure of either rod will result in free elevator only on the side of the failure. The airplane can then be controlled in pitch by the remaining elevator. The fallacy of the redundancy consideration, however, is the effect of a highly deflected elevator trim tab on a free elevator which, as demonstrated in this accident, can cause antisymmetric aerodynamic loading of the stabilizer. The Safety Board acknowledges that the EMB-110P1 and P2 flight control system design strength complied with the certification standards. Further, the conditions of this accident were unique in that the elevator trim tab was fully deflected, and the pilots were applying maximum force to achieve a desperate maneuver. However, the Board believes that the elevator control system should be of sufficient strength to withstand the maximum applied efforts of both pilots.

In September 1981, the manufacturer introduced a modification to the EMB-110P1 and P2 models to interconnect the right and left elevators at the elevator torque tube arms to reduce horizontal stabilizer and control column vibration. With the elevators interconnected, the failure of either elevator control rod would result in more critical loading of the remaining elevator control rod. Consequently, to preserve the redundancy of the control system, the modification required replacement of the original aluminum control rods with stronger control rods made from steel tubing. The modification was not considered a safety issue and was thus not mandated by either the CTA or the FAA.

Since this accident, both the CTA and the FAA have required operators to install the higher strength elevator control rods in EMP-110P1 and P2 airplanes. This modification, with or without the elevator torque tube arm interconnect, will prevent antisymmetric elevator deflection as it occurred during this accident. However, the Safety Board cannot positively conclude that the presence of higher strength control rods would have prevented an accident if the pilot experienced an elevator control system jam.

The regulation addressing trim systems also has remained unchanged since the U.S. certification of the EMB-110P1 and P2, and, as it relates to runaway protection, specifies that "proper precautions must be taken to prevent inadvertent, improper, or abrupt trim tab operation." The Safety Board has reviewed the design of the elevator trim system in the accident airplane. The only failure--a shorting of the 28V d.c. wire to a trim motor operating terminal in the pilots control wheel mounted trim switch which could result in the simultaneous operation of the trim motor and engagement of the trim motor clutch is a remote possibility. Should this occur, the control forces will progressively increase as the tab moves to full deflection during a period of about 30 seconds. During this period, the pilot would be expected to act to remove electrical power from the system. Based on the remote possibility of inadvertent operation, and the several means by which the pilot can cope with such an emergency, the Safety Board concludes that the elevator trim system conformed to the certification criteria.

## 2.17 Flight Data and Cockpit Voice Recorders

The Safety Board believes that the facts and circumstances of this accident further illustrate the need for a requirement that flight data recorders (FDR) and cockpit voice recorders (CVR) be installed in multiengine, turbine-powered, fixed-wing airplanes. Recorded flight parameters and CVR conversation would have provided significant clues regarding the cause of this accident and permitted more timely and positive identification of the remedial action needed to prevent recurrence. Although the Safety Board is encouraged by the FAA's notice of proposed rule making (NPRM) concerning the installation of CVRs on multi-engine, turbine-powered, fixed-wing aircraft operating under 14 CFR 135, it is concerned that a final rule has yet to be issued and urges the FAA to expedite its implementation.

On October 1, 1981, Sky Train Air, Inc., Gates Learjet 24, N44CJ, made an unexpected descent from its cruising altitude of flight level (FL) 450 (45,000 feet). No radio transmissions were received from the flightcrew just before and during the uncontrolled descent. The aircraft crashed near Felt, Oklahoma, and disintegrated on ground impact, fatally injuring the three company pilots onboard. The degree of aircraft destruction and the lack of cockpit voice recorder (CVR) and flight data recorder (FDR) information prevented the Safety Board from determining precisely the circumstances of the accident. 6/ In a letter to the FAA, dated August 31, 1982, the Safety Board stated:

6/ Aircraft Accident Report—"Sky Train Air, Inc., Gates Learjet 24, Felt, Oklahoma, October 1, 1981" (NTSB/AAR-82/4).

The safety of the flying public and the prevention of accidents through knowledge of the causes of previous accidents is a major concern of aircraft manufacturers, aircraft users, the FAA, and the Safety Board. The Safety Board's determination of probable cause in a number of accidents involving multiengine, turbine-powered aircraft that were not equipped with flight recorders since they were not subject to the requirements of 14 CFR 121.343 (FDR) or 14 CFR 121.359, 135.151, and 127.127 (CVR) has been severely hampered by the lack of FDR and CVR information. Our experience in air carrier accident investigation has proven that these devices are exceptionally valuable tools in identifying operational and mechanical problems, weather- and turbulence-induced occurrences, and other subtle human influences that can contribute to an accident. In the past 10 years, one or both of the recorders has provided investigators with the necessary clues to piece together the circumstances of the accident in virtually all cases. The availability of recorder information has clearly enhanced the aviation community's ability to improve flying safety and to prevent accidents.

\* \* \*

Between 1971 and 1980 . . . there were 180 fatal general aviation accidents in the U.S. involving multiengine, turbine-powered aircraft. In 88 percent of these, the aircraft was destroyed, and in 53 percent of those destroyed the aircraft suffered fire after impact. We maintain that the condition of the wreckage in these cases coupled with the lack of cockpit voice recorder and flight data recorder information has prevented the Safety Board from fully and accurately assessing all of the factors associated with these accidents. Although the Safety Board assigned a probable cause for most of these, the body of the NTSB accident reports explains the degree of uncertainty associated with each, and the necessity for recorders.

As a result of its investigation, the Safety Board recommended that the FAA:

- Require that all multiengine, turbine-powered, fixed-wing aircraft certificated to carry six or more passengers manufactured on or after a specified date, in any type of operation not currently required by 14 CFR 121.343, 122.359, and 135.151 to have a cockpit voice recorder and/or a flight data recorder, be required to accept a "general aviation" cockpit voice recorder (if also certificated for two-pilot operation) with at least one channel for voice communications transmitted from or received in the aircraft by radio, and one channel for audio signals from a cockpit area microphone, and a "general aviation" flight data recorder to record sufficient data parameters to determine the information in Table I (see appendix F) as a function of time. (A-82-101)

Require that "general aviation" cockpit voice recorders (on aircraft certificated for two-pilot operation) and flight data recorders be installed when they become commercially available as standard

equipment in all multiengine, turbine-powered fixed-wing aircraft and rotorcraft certificated to carry six or more passengers manufactured on or after a specified date, in any type of operation not currently required by 14 CFR 121.343, 121.359, 135.151, and 127.127 to have a cockpit voice recorder and/or a flight data recorder. (A-82-109)

Require that "general aviation" cockpit voice recorders be installed as soon as they are commercially available in all multiengine, turbine-powered aircraft (both airplanes and rotorcraft), which are currently in service, which are certificated to carry six or more passengers and which are required by their certificate to have two pilots, in any type of operation not currently required by 14 CFR 121.359, 135.151, and 127.127 to have a cockpit voice recorder. The cockpit voice recorders should have at least one channel reserved for voice communications transmitted from or received in the aircraft by radio, and one channel reserved for audio signals from a cockpit area microphone. (A-82-110)

Require that "general aviation" flight data recorders be installed as soon as they are commercially available in all multiengine, turbojet airplanes which are currently in service, which are certificated to carry six or more passengers in any type of operation not currently required by 14 CFR 121.343 to have a flight data recorder. Require recording of sufficient parameters to determine the following information as a function of time (see Table I (see appendix F) for ranges, accuracies, etc.):

- altitude
- indicated airspeed
- magnetic heading
- radio transmitter keying
- pitch attitude
- roll attitude
- vertical acceleration
- longitudinal acceleration
- stabilizer trim position
- or pitch control position.

(A-82-111)

The current requirement, under 14 CFR Part 135 specifies that all turbojet airplanes certificated to carry 10 or more passengers must be equipped with a CVR. A Notice of Proposed Rule Making (NPRM), which has not yet been implemented by the FAA, would amplify the 14 CFR Part 135 requirement for a CVR to include newly manufactured multi-engine turbine-powered airplanes (date 2 years after the effective date of the amendment) certificated to carry six or more passengers and requiring two or more pilots by certification or operating rules. The NPRM fails to address the pre-wiring for CVR and FDR of all newly manufactured multi-engine turbine-powered airplanes certificated to carry six passengers or more, would not require the installation of FDRs (when commercially available) on newly manufactured multi-engine turbine-powered airplanes certificated to carry six passengers or more, would not require that multi-engine turbine-powered airplanes certificated to carry six passengers or more now in service be



retrofitted with CVRs, and would not require that turbojet airplanes certified to carry six passengers or more now in service be retrofitted with FDRs. Consequently, the Safety Board has classified Safety Recommendations A-82-107 and A-82-109 through -111 as "Open—Unacceptable Action." However, the Safety Board believes that the matter of flight parameters has been neglected and needs to be addressed. Therefore, the Board reiterates Safety Recommendations A-82-107 and A-82-100 through -111.

### 3 CONCLUSIONS

#### 3.1 Findings

1. The airplane's elevator tips, elevators, and horizontal stabilizer separated in flight.
2. The flight appeared to have been normal up to an altitude of about 600 feet a.g.l. and near the end of the runway when the captain routinely acknowledged an instruction to contact departure control.
3. The first separation occurred about 6,000 feet beyond the end of the runway and about 25 to 30 seconds after the time the airplane passed the end of the runway.
4. The accident was considered to be nonsurvivable because the impact forces exceeded the limitations of human tolerance and the decreased cabin volume was insufficient to support human life.
5. The flight crewmembers were properly certificated.
6. No medical or psychological conditions were found which might have adversely affected the flightcrew's performance.
7. Both engines were operating normally until impact.
8. The propellers were intact and undamaged until impact.
9. All fractures and deformations of the right engine mounts resulted from impact.
10. The engine mounts were not subjected to any centrifugally induced vibration forces.
11. There was no evidence of any turbulence or windshear at the time of the accident.
12. There was no evidence of any significant turbulence on the previous flight.
13. There was no damage to the structure which might suggest a pre-flight collision with another vehicle.
14. The stabilizer forward attachment structure was fully capable of carrying its ultimate design loads.

15. The structural failure was not caused by a divergent aerodynamic flutter.
16. The separation of the horizontal stabilizer was caused by an abnormal asymmetrical air load on the stabilizer.
17. Structural failure was preceded by some other failure or malfunction of the airplane's elevator control system.
18. The aft fracture of the left elevator control rod was due to compression buckling at or near the midpoint.
19. The aft fracture of the left elevator control rod occurred before **the** elevator separated **from** the stabilizer.
20. The elevator control rod failed in compression buckling with an applied load of about 466 pounds.
21. The elevator control rod would fracture at its midpoint when the load is applied through the rod end bearings, as it would be applied in the normal flight through pilot input.
22. A combination of commanded aircraft nose up pitch attitude and nose down trim tab deflection results in compression forces in both the left and the right control rods, with the force in the left rod being the greatest.
23. The control column pull force required to cause a compression failure of the left elevator control rod would approach or exceed the maximum two-hand pull force of about 200 pounds, which can be applied by one male pilot of average strength.
24. The trim tab actuator indicated full trailing edge up trim tab deflection (airplane nose down).
25. The separation of the elevator tips from the elevators and the elevators from the stabilizer occurred during or immediately after the horizontal stabilizer attachment failed and as a result of inertial and aerodynamic loads which were imposed on the stabilizer and elevator assembly during its separation from the fuselage.
26. The left elevator trim tab requires about 30 seconds to travel from an approximately neutral takeoff trim position to the full trailing edge up position.
27. A runaway trim condition can be controlled by about 5 pounds of pressure on the trim wheel, by pulling the trim system circuit breaker, and by pilot pull force, the magnitude of which increases with airspeed.
28. An uncommanded nose down trim with no aural warning might occur if a motor power wire should touch the adjacent terminal for the nose down trim selection wire.

29. A stuck trim switch could result in failure to **return** to neutral and, in **known** cases, could **be** neutralized with **the** thumb.
30. There are **known** instances of service difficulties with frayed **stainless** steel and carbon **steel** elevator cables which could lead to **the jamming** of the cables within a fairlead block near the midsection of the cable run.
31. It was not possible to determine the initial event which resulted in the full trailing edge up deflection of the elevator trim tab.
32. The wing trailing edge **flaps** and **the** landing **gear** were in the retracted position at impact.
33. **The** EMB-110P1 airplane had been properly certificated in accordance with the provisions for the **certification** of **a** product that is **manufactured** in a foreign country.
34. The installation of a stronger **steel** elevator control rod in place of the aluminum elevator control rod which was installed in the accident airplane would have prevented **rod** failure and consequent differential elevator deflection but might not have prevented an accident if the pilot **experienced** an elevator control system jam.
35. The elevator trim system conformed to certification criteria.
36. The installation of an FDR **and** CVR would have **provided** significant clues regarding the cause **of** this accident and **remedied** action needed to prevent recurrence.

### 3.2 probable Cause

The National Transportation Safety Board determines that **the probable cause** of this accident was a malfunction of either the elevator control system or the elevator trim system, which resulted in **an** airplane pitch control problem. The reaction of the flightcrew to correct the pitch control problem overstressed the left elevator control **rod**, which resulted in **asymmetrical** elevator deflection and overstress failure of the horizontal stabilizer attachment structure. The Safety Board was not **able** to determine **the** precise problem with the pitch control system.

## 4. RECOMMENDATIONS

On January 8, 1985, the National Transportation Safety Board recommended that the FAA:

Issue an airworthiness directive (AD) to require that before further commercial operation in the United States, the horizontal stabilizer attachment **of** EMB-110P1 and -110P2 model airplanes not previously modified in accordance with **AD 83-14-09**, Amendment **39-4527**, paragraph (d) or (e), be inspected **using** an improved inspection procedure to enhance detection of loose or sheared rivets, particularly where bulkhead **33** transmits the loads from the stabilizer forward attachment to the fuselage monocoque structure. The inspection procedure should require removal of

controls **as** needed for access to riveted joints and application of external loads to detect relative movement between structural members. The AD should require that deficiencies detected during inspection **be** reported to the FAA and that they **be** corrected in accordance with an approved procedure before further flight. (A-85-01)

Revise airworthiness directive (AD) 83-14-09 to require within a specified period that the horizontal stabilizer attachment structure of EMB-110P1 and -110P2 model airplanes **be** modified in a manner similar to that described in Amendment 39-4527, paragraph (d) or (e), which requires the repair of any cracks in the web of bulkhead 33 **and** the replacement of the original "C" channels with redesigned channels and modified rivet patterns. Review the crack repair procedures of the AD for adequacy, and require modification of the procedures to eliminate "bucking" of rivets at locations difficult to access **and** other procedures likely to damage existing structure. (A-85-02)

Conduct a directed safety investigation of EMB-110P1 and -110P2 model airplanes that have been modified in accordance with the provisions of AD 83-14-09 (Amendment 39-4527, paragraph (d) or (e)), to determine whether any structural damage has been inflicted in the area where the horizontal stabilizer attaches to bulkhead 33 and take the corrective action indicated by the results of the directed safety investigation. (A-85-03)

Notify appropriate foreign civil aviation authorities and/or foreign operators of EMB-110P1 and -110P2 model airplanes of the circumstances of the Provincetown-Boston Airlines accident of December 6, 1984, and of the actions recommended to U.S. operators. (A-85-04)

In response to Safety Recommendation A-85-01 the FAA issued Emergency Airworthiness Directive 85-01-51 on January 10, 1985, which **required** a comprehensive inspection of the EMB-110P1 and 110P2 model airplanes addressed in the above recommendations. **As** a result, the Safety Board classified Safety Recommendation A-85-01 as "Closed—Acceptable Alternate Action."

In **regard** to Safety Recommendation A-85-02, the FAA indicated that structural testing by Embraer had eliminated the need for modifications to the horizontal stabilizer attachment structure. The Safety Board agrees that the tests showed that the stabilizer forward attachment structure at bulkhead 33 would carry ultimate stabilizer loads even though weakened by cracks and the removal of fasteners in the bulkhead web. Nevertheless, the Safety Board is concerned that the tests were not sufficient to show conclusively whether the resulting change in load distribution would affect the fatigue life of the redundant load path. In view of FAA's intent not to comply with this recommendation, it has been classified as "~~Closed~~—Unacceptable Action."

Safety Recommendation A-85-03 **was** classified as "Closed—Acceptable Alternate Action," due to the fact that the discrepancies created by accomplishing the modification in accordance with paragraphs (d) and (e) of AD 83-14-09, which **was** issued August 9, 1983, were limited to a single operator; no discrepancies were noted by FAA inspectors; and **all** Embraer operators were apprised of the possibility of inflicting damage while **modifying** the area between bulkheads Nos. 32 and 33.

Safety Recommendation A-85-04 also was classified as "Closed—Acceptable Alternate Action," based on the FAA's action of telephoning the complete text of the Safety Board's recommendation to the CTA as an alternate to a direct notification to foreign civil aviation authorities.

AD 85-17-04 regarding the inspection and replacement of elevator control rod tubes was issued August 30, 1985, and AD 85-18-51 regarding the deactivation of the Bendix electric trim switches and autopilots was issued September 12, 1985, following the public hearing conducted by the Safety Board on August 6-8, 1985. (See appendix E.)

Also, the Safety Board reiterates the following recommendations to the Federal Aviation Administration:

Require that all multiengine, turbine-powered, fixed-wing aircraft certificated to carry six or more passengers manufactured on or after a specified date, in any type of operation not currently required by 14 CFR 121.343, 122.559, and 135.151 to have a cockpit voice recorder and/or a flight data recorder, be prewired to accept a "general aviation" cockpit voice recorder (if also certificated for two-pilot operation) with at least one channel for voice communications transmitted from or received in the aircraft by radio, and one channel for audio signals from a cockpit area microphone, and a "general aviation" flight data recorder to record sufficient data parameters to determine the information in Table I (see appendix F) as a function of time. (A-82-107)

Require that "general aviation" cockpit voice recorders (on aircraft certificated for two-pilot operation) and flight data recorders be installed when they become commercially available as standard equipment in all multiengine, turbine-powered fixed-wing aircraft and rotorcraft certificated to carry six or more passengers manufactured on or after a specified date, in any type of operation not currently required by 14 CFR 121.343, 121.359, 135.151, and 127.127 to have a cockpit voice recorder and/or a flight data recorder. (A-82-109)

Require that "general aviation" cockpit voice recorders be installed as soon as they are commercially available in all multiengine, turbine-powered aircraft (both airplanes and rotorcraft), which are currently in service, which are certificated to carry six or more passengers and which are required by their certificate to have two pilots, in any type of operation not currently required by 14 CFR 121.359, 135.151, and 127.127 to have a cockpit voice recorder. The cockpit voice recorders should have at least one channel reserved for voice communications transmitted from or received in the aircraft by radio, and one channel reserved for audio signals from a cockpit area microphone. (A-82-110)

Require that "general aviation" flight data recorders be installed as soon as they are commercially available in all multiengine, turbojet airplanes which are currently in service, which are certificated to carry six or more passengers in any type of operation not currently

required by 14 CFR 121.343 to have a flight data recorder. Require recording of sufficient parameters to determine the following information as a function of time (see Table I (see appendix F) for ranges, accuracies, etc.):

altitude  
indicated airspeed  
magnetic heading  
radio transmitter keying  
pitch attitude  
roll attitude  
vertical acceleration  
longitudinal acceleration  
stabilizer trim position  
or pitch control position.

(A-82-111)

**BY THE NATIONAL TRANSPORTATION SAFETY BOARD**

/s/ PATRICIA A. GOLDMAN  
Acting Chairman

/s/ JIM BURNETT  
Member

/s/ JOHN K. LAUBER  
Member

/s/ JOSEPH T. NALL  
Member

June 24, 1986

## 5. APPENDIXES

### APPENDIX A

#### INVESTIGATION AND HEARING

##### 1. Investigation

The National Transportation Safety Board was notified of the accident at about 1850 on December 6, 1984, and immediately dispatched an investigative team to the scene. Investigative groups were established for operations/air traffic control, survival factors, structures, powerplants, systems, maintenance records, performance, metallurgy, and structural loads evaluation.

Parties to the investigation were the Federal Aviation Administration; Provincetown-Boston Airlines, Inc.; Embraer Aircraft Corporation; Pratt and Whitney Engine Company; Hartzell Propellers; and the Jacksonville, Florida, Port Authority.

##### 2. Public Bearing

A 3-day public hearing was held at Marco Island, Florida, beginning on August 6, 1985. Parties represented at the hearing were the Federal Aviation Administration, Provincetown-Boston Airlines, Inc., and Embraer Aircraft Corporation.

APPENDIX B

PERSONNEL INFORMATION

Thomas Michael Ashby

Captain Thomas Michael Ashby, 34, was hired by PBA on February 16, 1974. He held airline transport pilot certificate No. 1985515 with airplane multiengine land, DC-3, EMB-110, M-202, M-404, and YS-11 ratings and a commercial certificate with airplane and single engine land ratings. At the time of the accident, he had flown about 10,000 hours with about 400 hours in the EMB-110P1. Captain Ashby was issued a first class medical certificate on June 5, 1984, with no limitations. He received a type rating in the EMB-110P1 on October 4, 1983. His last proficiency check in the EMB-110P1 was on December 1, 1984. At the time of the accident, he had accumulated approximately 10,000 hours of flying time with approximately 400 hours in the EMB-110.

Louis Ricardo Fernandez

First Officer Louis Ricardo Fernandez, 25, was hired by PBA on July 11, 1984. He held airline transport pilot certificate No. 261371891 with airplane and multiengine land ratings and a commercial pilot certificate with airplane, single engine land and sea ratings. At the time of the accident, he had flown about 3,000 hours with about 500 hours in the EMB-110. First Officer Fernandez was issued a first class medical certificate on June 27, 1984, with the limitation that the "holder shall have available for use corrective lenses for distant vision while exercising the privileges of his airman's certificate." He received his initial training in the EMB-110P1 on July 20, 1984. His last proficiency check in the EMB-110P1 was completed on December 4, 1984, in N98PB. At the time of the accident, he had accumulated approximately 3,000 hours of flying time with approximately 500 hours in the EMB-110.



**APPENDIX C**

**AIRCRAFT INFORMATION**

**N96PB, S/N 110365, was purchased by PBA from the manufacturer in October 1981 and had been operated continuously by PBA. The aircraft had flown a total of 5,662.4 hours and 7,858 cycles on December 5, 1984, the day before the accident, PBA maintained the aircraft under a continuous airworthiness inspection program.**

The basic program consisted of five numbered inspections and five letter checks. Letter checks consisted of a **visual** examination or check of the appliances, the aircraft, and its components and systems insofar **as is** practicable without disassembly. Numbered inspections consisted of a thorough examination of the appliances, the aircraft, and its components and systems with disassembly **as** necessary. Numbered inspections I through V were performed as follows: I at the **first 100** hours and every 1,000 hours thereafter, II at the first **300** hours and every 1,000 hours thereafter, III at the first **500** hours and every **1,000** hours thereafter, IV at the first **700** hours and every **1,000** hours thereafter, and V at the **first 900** hours and every 1,000 hours thereafter. Letter checks were performed **as** follows: A check at **50** hours, B check in conjunction with A check at 200 hours, C check at 1,000 hours, D check at **3,000** hours, and E check at **6,000** hours. The last inspection of the aircraft was completed on November 6, 1984, and **consisted of** letter checks A and B. The total time on the aircraft **as of** that date was **5,639.2** hours. The aircraft records indicated that the aircraft had been maintained in accordance with PBA procedures and with Federal Aviation Regulations.

**APPENDIX D  
WRECKAGE DIAGRAM**

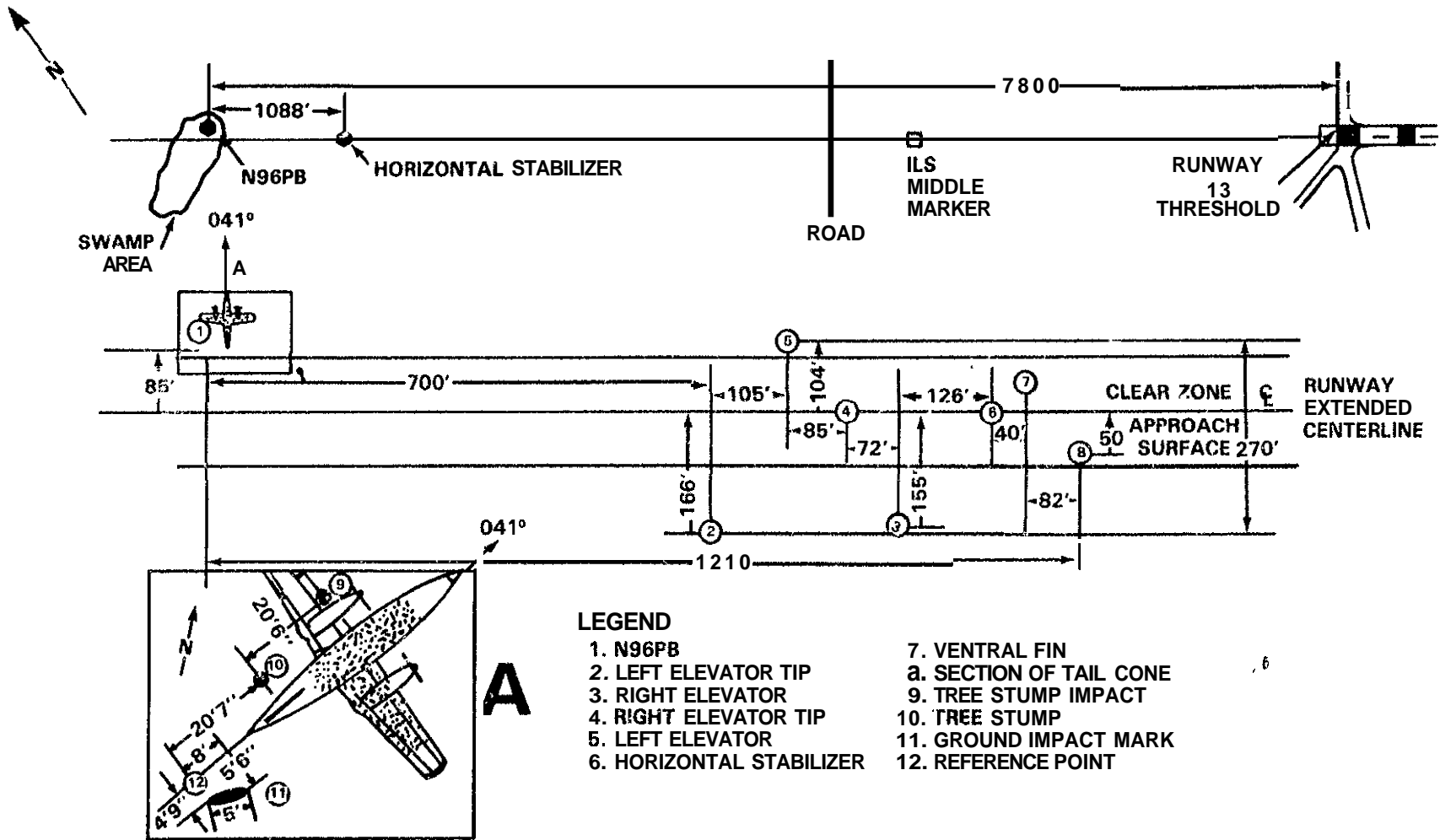

**APPENDIX E**  
**AIRWORTHINESS DIRECTIVES**  
**AND**  
**SERVICE BULLETINS**

83-14-09 **EMBRAER**: Amendment 39-4692. Applies to Models EMB-110P1 and EMB-110P2 (S/N 110001 through 110386, 110388 through 110397, 110399 through 110401, 110404 through 110408, 110410 through 110412, 110414, 110415 and 110421) airplanes certificated in any category.

Compliance: Required as indicated, unless already accomplished.

To preclude structural failure of the horizontal stabilizer front attachment and fuselage bulkhead 33, accomplish the following:

a) Within the next 50 hours time-in-service after the effective date of this AD, and thereafter at intervals not to exceed 500 hours time-in-service, except as provided in paragraph b) of this AD, visually inspect:

1) The rivets (MS20470AD4) that attach the "C" channels (P/N 4A-1419-05/06/07/08) to the upper and lower flanges of the "U" shaped machined parts (P/N 4A-1411-07-16/17) for looseness (see Figure 2, EMBRAER Service Bulletin ((SB)) No. 110-53-019, hereinafter referred to as the SB).

2) The rivets (MS20470AD3) that attach the fuselage skin to the "C" channels described in paragraph a)1) above and the two lower adjacent channels for looseness (see Figure 3 of the SB).

3) The web or flange areas of bulkhead 33 adjacent to the horizontal stabilizer front fittings, at each side of the fuselage for cracks (see Figure 2, Section C-C of the SB).

b) If loose rivets are found during any inspection required by paragraph a)1) above, in either the upper or lower "C" channel attachments, repeat the inspections in paragraph a) of the AD at intervals not to exceed 125 hours time-in-service until not more than 500 hours time-in-service is accumulated, at which time replace all five rivets (MS20470AD4) in the flange having the loose rivets with Hi-Lock rivets HL-22-77-5-4 or AN3-5A bolts. If loose rivets are found during any inspection required by paragraph a)2) above, in both the upper and lower "C" channels, prior to further flight replace the rivets. The detailed rivet replacement is shown in Figure 3 of the SB. Accomplish the repetitive inspections of those flanges in which rivets have been replaced at intervals not to exceed 500 hours time-in-service until the "C" channel attachments are reinforced in accordance with the procedures shown in Figure 4 of the SB.

c) If cracks are found during any inspection required by paragraph a)3) of this AD, accomplish the following:

1) If cracks are less than 3 inches, repeat the repetitive visual inspections at intervals not to exceed 125 hours time-in-service until not more than 1000 hours time-in-service is accumulated, at which time repair bulkhead 33 in accordance with Figure 5 of the SB, reinforce the "C" channel attachments, and replace the rivets of the horizontal stabilizer front attachment structure in accordance with Figure 4 of the SB if not previously accomplished. If possible, stop drill the crack ends.

2) If cracks are 3 inches or longer, prior to further flight, repair bulkhead 33 web in accordance with Figure 5 of the SB, reinforce the "C" channel attachments, and replace the rivets of the horizontal stabilizer front attachment structure in accordance with Figure 4 of the SB.

3) If the horizontal stabilizer forward attachment fitting (P/N 110-1411-07-29) rides on the corner of the reinforcing plate (P/N 4A-1419-09), remove excess material from the upper inboard corner of the reinforcing plate (P/N 4A-1419-09), to provide for a proper fit.

ORIGINAL AS  
RECEIVED BY ATP

d) If no cracks are found in the bulkhead 33 web during any inspection required by paragraph a) of this AD, the repetitive inspections of that paragraph are no longer required when the "C" channel attachments are reinforced and the rivets of the horizontal stabilizer front attachment are replaced in accordance with the procedures shown on Figure 4 of the SB.

e) The repetitive inspections required by paragraphs b) and c) of this AD are no longer required when the bulkhead 33 web is repaired in accordance with Figure 5 of the SB and the "C" channel attachments are reinforced and the horizontal stabilizer front attachment rivets are replaced in accordance with Figure 4 of the SB.

f) The intervals between the repetitive inspections required by this AD may be adjusted up to 10 percent of the specified interval to allow accomplishing these inspections concurrent with other scheduled maintenance of the airplane.

g) Aircraft may be flown in accordance with FAR 21.197 to a location where this AD can be accomplished.

h) An equivalent method of compliance with this AD may be used if approved by the Manager, Atlanta Aircraft Certification Office, ACE-115A, 1075 Inner Loop Road, College Park, Georgia 30337; telephone (404) 763-7428.

This amendment becomes effective July 27, 1983

83-15-10 **EMBRAER**: Amendment 39-4699. Applies to Models **EMB-110P1** and **EMB-110P2** (S/N 110001 through 110386, 110388 through 110397, 110399 through 110401, 110404 through 110408, 110410 through 110412, 110414 and 1104211 airplanes certificated in any category.

Compliance: Required as indicated, unless already accomplished.

To preclude flutter from occurring in any control surface, accomplish the following:

a) Within the next 30 days after the effective date of this AD, check the elevators for static balance in accordance with the procedures shown in Item 1.118 of the **EMBRAER** structural Repair Manual, T.O.-IC95-3 and T.O.-IC95A-3. If an unbalanced condition is found, prior to further flight, rebalance the elevator in accordance with the procedures shown in Item 1.119 of the **EMBRAER** Structural Repair Manual, T.O.-IC95-3 and T.O.-IC95A-3, but replace Figure 1-24 with Figure 1 of this AD. Do not exceed the mass balance weight values of Table 1-6A of this AD.

b) Within the next 60 days after the effective date of this AD, check the ailerons and rudder for static balance in accordance with the procedures shown in Item 1.118 of the **EMBRAER** Structural Repair Manual, T.O.-IC95-3 and T.O.-IC95A-3. If an unbalanced condition is found, prior to further flight, rebalance the ailerons and rudder in accordance with the procedures shown in Item 1.119 of the **EMBRAER** Structural Repair Manual, T.O.-IC95-3 and T.O.-IC95A-3, but replace Figure 1-24 with Figure 1 of this AD. Do not exceed the mass balance weight values of Tables 1-6B and 1-6C, respectively, of this AD.

c) When checking the balance of the control surfaces in accordance with paragraphs a) and b) of this AD;

1) Remove the surface from the airplane, complete, finished and painted, static discharge wicks installed, trim tab activating rod installed, trim tab activating teleflex cable (case of the left elevator) installed and attached as the airplane. In this case, the elevator trim tab teleflex cable must be attached to the bellcrank by the clamp only.

d) Aircraft may be flown in accordance with FAR 21.197 to a location where this AD can be accomplished.

e) An equivalent method of compliance with this AD, if used, must be approved by the Manager, Atlanta Aircraft Certification Office, ACE-115A, 1075 Inner Loop Road, College Park, Georgia 30337.

This amendment becomes effective August 9, 1983.

**EMBRAER**  
**Airworthiness Directive**  
**Final Copy of Telegram**  
**Revision**  
**Volume I**

84-24-53 R1 EMBRAER: Amendment 39-4975. Applies to Models EMB-110P1 and EMB-110P2 airplanes certificated in any category.

Compliance: Required within the next ten (10) hours time-in-service, unless previously accomplished within the last fifty (50) hours time-in-service.

To preclude possible structural failure of the empennage assembly, accomplish the following:

(a) Unless the structural reinforcements and rivet replacements specified in paragraphs (d) and (e) of AD 83-14-09 (Amendment 39-4692) have already been accomplished, repeat the inspections of the horizontal stabilizer front attachment and fuselage bulkhead 33 area in accordance with paragraph (a) of AD 83-14-09.

(b) If loose rivets or cracks of any length are found during the inspections required by paragraph (a), prior to further flight, replace the rivets in accordance with paragraph (b) of AD 83-14-09 and repair the cracks in accordance with paragraph (c) E2) of AD 83-14-09 notwithstanding the three inch crack criteria of that paragraph.

(c) Visually inspect the following components for loose attachments, excessive wear, corrosion, cracks and structural deformation:

(1) Forward horizontal stabilizer attachment, including the fuselage and stabilizer attach fittings and attachment hardware.

(2) Aft horizontal stabilizer attachment, including the fuselage and stabilizer attach fittings, attach liakr and all attachment hardware.

(3) All elevator Bo stabilizer hinge fittings, including all bearings/bushings and attachment hardware.

(4) Security of elevator oars balance weight assemblies.

(5) Left and right elevator Bellcrank assemblies and attachment hardware.

(6) Left and right elevator torque tube assemblies and all attachment hardware.

(7) Elevator trim tab binges.

(8) Elevator trim tab actuator, bearings, push rod assembly and all attachment hardware.

(9) Elevator trim tab free play, measured at the trailing edge, should not exceed airplane maintenance manual limits.

(d) Prior to further flight, correct any unsatisfactory conditions found as a result of the inspections required by

**EMPRESA BRASILEIRA DE AERONAUTICA**  
**Airworthiness Directive**  
**Final Copy of Telegram**  
**Volume I**

85-01-51 ENBRAER: Amendment 39-5004. Applies to Models EMB-110P1 and EMB-110P2 (all serial numbers) airplanes certificated in any category.

Compliance: Required within the next 15 hours time-in-service after the effective date of this AD unless either previously accomplished within the past 50 hours time-in-service or modified per paragraphs d) and e) of AD 83-14-09.

To preclude possible structural failure of the empennage assembly, accomplish the following:

(1) Remove elevator preload springs from cross brace in empennage.

(2) Remove the cross brace in the empennage that contains the elevator preload springs (rivets will have to be drilled out).

(3) Gain access to the affected area through the inspection panel forward of bulkhead 34, releasing the elevator and rudder control cables if necessary for good access,

(4) Position a person in the empennage and inspect for loose, cocked or sheared rivets and signs of fretting in the areas indicated on Figure 2, Page 17 of ENBRAER Service Bulletin No. 110-53-019, Change 2, dated April 13, 1984, using mirror, light, and .010-inch feeler gauge. Attempt to insert feeler gauge between machined "U" channel and reinforcement ribs to determine if gap exists.

(5) The person stationed in the empennage should place his finger up against the machined "U" channel resting on reinforcement ribs left and right sides (P/N 4A-1419-07 L/R, P/N 4A-1419-08, P/N 4A-1419-05 L/H, and P/N 4A-1419-06) (see above service bulletin). while the horizontal stabilizer is deflected as indicated in (6) below.

(6) Position a person at the horizontal stabilizer tip end attempt to deflect the stabilizer tip up and down approximately 3 inches, but no more than 3 inches. The person stationed inside the tail should try to detect any relative movement between structural members. Any movement requires removing all rivets attaching machined "U" channel and replacing them as specified in AD 83-14-09.

(7) Prior to further flight, Correct any discrepancies found, reassemble and inspect assembly per AD 83-24-09.

(8) Report completion of inspection and any unsatisfactory conditions within 24 hours to the FAA, Airframe Branch, Atlanta Aircraft Certification Officer Telephone (404) 763-7407. Include in such reports the type and location of discrepancies,

**EMPRESA BRASILEIRA DE AERONAUTICA**  
**Airworthiness Directive**  
**Volume I**

**85-17-04 EMPRESA BRASILEIRA DE AERONAUTICA S.A. (EMBRAER):**  
**Amendment 39-5126. Applies to Models EMB-110P1 and EMB-110P2**  
**(all serial numbers) airplanes certificated in any category**  
**which have aluminum elevator control rod tubes installed.**

**Compliance: Required as indicated, unless already**  
**accomplished.**

**To prevent failure of the elevator control rod tube,**  
**accomplish the following:**

**(a) Within the next 50 hours time-in-service after the**  
**effective date of this AD, visually inspect the elevator**  
**control rod tubes, P/N 4A-500-10-09-01, for evidence of**  
**corrosion or cracks. If corrosion or cracks are found, prior**  
**to further flight replace the control rod tube in accordance**  
**with Embraer Service Bulletin (S/B) No. 110-27-076, Revision**  
**01, dated July 2, 1985.**

**(b) Within 150 hours time-in-service or 30 (thirty)**  
**days, whichever occurs first, after the effective date of this**  
**AD, replace both left and right elevator aluminum control rod**  
**tubes P/N 4A-500-10-09-01 with steel control rod tubes PIN**  
**110-500-10-06-04-01. Reidentify the elevator control rod**  
**assembly with the new P/N 110-500-10-00-09.**

**(c) Airplanes may be flown in accordance with Federal**  
**Aviation Regulation 21.197 to a location where the AD may be**  
**accomplished.**

**(d) An equivalent method of compliance with this AD**  
**may be used if approved by the Manager, Atlanta Aircraft**  
**Certification Office, FAA, 1075 Inner Loop Road, College Park,**  
**Georgia 30337; Telephone (404) 763-7428.**

**All persons affected by this directive may obtain copies of**  
**the documents referred to herein upon request to Embraer, Post**  
**Office Box 343 - CEP 12.200 Sao Jose Dos Campos, Sao Paulo,**  
**Brazil, or FAA, Office of Regional Counsel, Room 1558, 601 East**  
**12th Street, Kansas City, Missouri 64106.**

**This amendment becomes effective on August 30, 1985.**

**FOR FURTHER INFORMATION CONTACT:**

**Mr. Curtis A. Jackson, ACE-120A, Atlanta Aircraft Certification**  
**Office, Central Region, Federal Aviation Administration, 1075**  
**Inner Loop Road, College Park, Georgia 30337; Telephone (404)**  
**763-7107.**

EMPRESA BRASILEIRA DE AERONAUTICA (EMBRAER)  
Airworthiness Directive  
Volume I

T85-18-51 EMBRAER: Telegram issued September 12, 1985. Applies to Embraer Model EMB-110P1 and EMB-110P2 airplanes (all serial numbers) certificated in any category that have the Bendix electric trim system installed.

Compliance required within the next 10 hours time in service after receipt of this telegraphic AD unless already accomplished.

To prevent failure of the Bendix electric trim switch resulting in a runaway trim condition, accomplish the following:

(A) Disconnect the electric power source to the Bendix trim servo by disconnecting the trim servo plug located in the aft fuselage section. Cap, protect, and secure the plug.

(B) Fabricate and install on the instrument panel visible to both pilots the following placard using letters of a minimum of 0.10 inch in height.

"ELECTRIC TRIM SYSTEM INOPERATIVE PER AD T85-18-51"

(C) Insure that the manual trim system is operational in accordance with the appropriate maintenance manual.

(D) If a Bendix automatic pilot is installed, disconnect the automatic pilot system from the electric power source and install in full view of both pilots the following placard using letters of a minimum 0.10 inch in height.

"AUTOPILOT INOPERATIVE PER AD T85-18-51"

(E) Aircraft may be flown in accordance with FAR 21.307 to a location where this AD can be accomplished, provided the circuit breakers for the electric trim system, and if applicable, for the automatic pilot system are pulled and the manual trim system is operational.

(F) An equivalent method of compliance with this AD may be used if approved by the Manager of the Atlanta Aircraft Certification Office, 1075 Inner Loop Road, College Park, Georgia 30331, telephone (404) 763-7628.

This airworthiness directive becomes effective upon receipt.

FOR FURTHER INFORMATION CONTACT:

Mr. Paul Sconyers, Atlanta Aircraft Certification Office,  
1075 Inner Loop Road, College Park, Georgia 30337, telephone  
(404) 763-7781.





EMPRESA BRASILEIRA DE AERONAUTICA S/A - S. JOSÉ DOS CAMPOS - SP

# SERVICE BULLETIN

## FLIGHT CONTROLS - ELEVATOR CONTROL MODIFICATION TO REDUCE CONTROL COLUMN VIBRATION (E.O. 110/6072, 6232)

### 1. PLANNING INFORMATION

#### 1.1 EFFECTIVITY

Aircraft Affected:

MODEL	S/N
EMB-110K1/P1/P2 "BANDEIRANTE".	110139 thru 110368, 110370 thru 110373, 110375 and 110376.

In-production effectivity:

Aircraft model EMB-110K1/P1/P2, S/N 110369, 110374, 110377 and on will have an equivalent modification factory-incorporated.

#### 1.2 REASON

Vibration in the control columns has been reported. Investigation has revealed that it is caused by horizontal tail surfaces vibration, which, in turn, is due to propeller slip-stream. This modification is intended to reduce control column vibration intensity, thus enhancing pilot comfort. In order to reduce the control column vibration more efficiently, it is also required to comply with S.B. 110-27-057.

#### 1.3 DESCRIPTION

The elevator control modification consists in the installation of an interconnect tube between the elevator actuating arms, which requires the drilling of holes in them. To keep actuating arms parallelism, a shim made of calibrated sheet metal is installed with the interconnect tube. The shim is fitted during the assembly. The control rods are replaced with steel tube control rods, so as to warrant the structural strength of one rod in case the other one

DATE 25 / Sep / 81

S.S. NO. 110-27-056 3  
PAGE 01 of 08



EMBRAER EMPRESA BRASILEIRA DE AERONAUTICA S/A - S. JOSÉ DOS CAMPOS - SP

# SERVICE BULLETIN

fails, since both elevators remain connected after the modification. Therefore, after the interconnection of the elevator actuating arms, the old rods made of aluminum tubing can no longer be used.

This Service Bulletin may be incorporated at any time, at operator's discretion.

## 1.4 APPROVAL

CIA/IFI - Certification Division.

## 1.5 MANPOWER REQUIRED

3 man-hours, approximately.

## 1.6 MATERIAL - COST AND AVAILABILITY

The material required for the accomplishment of this S.B. will be available from EMBRAER 90 days after receipt of orders, at the reference price of US\$ 294,81, subject to be confirmed on receipt of orders.

When ordering, specify Kit S.B. 110-27-056, comprising:

<u>P/N</u>	<u>DESCRIPTION</u>	<u>QTY</u>
110-500-10-00-05	Interconnect tube	01
110-500-10-00-06	Shim	01
110-500-10-00-04	Elevator control rod	02
AN3-4A	Bolt	02
AN3-6A	Bolt	06
AN3-7A	Bolt	02
M14-3	Nut	10
AN960D10	Washer	08
AN960-10L	Washer	10
MS35338-43	Lock washer	04
MS24665-136	Cotter pin	05

## 1.7 TOOLING - COST AND AVAILABILITY

Not applicable.

83.40 110-27-056

DATE: 25, Sep, 91.

4.



EMBRAER EMPRESA BRASILEIRA DE AERONÁUTICA S/A - R. JOSÉ DOS CAMPOS - SP

# SERVICE BULLETIN

1.8 WEIGHT AND BALANCE

1.9 REFERENCES

T.O. 1C95A-2-5 "Maintenance Manual - Flight Controls".

1.10 AFFECTED PUBLICATIONS

T.O. 1C95A-2-5 "Maintenance Manual - Flight Controls".

T.O. 1C95-4-5 "Illustrated Parts Breakdown - Flight Controls".

T.O. 1EMB110P1-4-5 "Illustrated Parts Breakdown - Flight Controls".

T.O. 1EMB110F2-4-5 "Illustrated Parts Breakdown - Flight Controls".

## 2. ACCOMPLISHMENT INSTRUCTIONS

The steps below provide general instructions for the accomplishment of this bulletin. Detailed instructions are presented as figure notes.

2.1 Gain access to the area to be worked on as per instructions in figure 1.

2.2 Replace the elevator control rods, as per instructions in figure 1.

2.3 Install the interconnect tube between the elevator actuating arms, as per instructions in figure 1.

2.4 Carry out an operational check-out on the elevator control system, as per instructions in T.O. 1C95A-2-5, "Maintenance Manual - Flight Controls" and, if necessary, rig the system.

2.5 Restore aircraft to normal.

2.6 Enter the accomplishment of this bulletin in the applicable document.

DATE: 25 / Sep / 81

S.S. Nº. 110-27-056 5  
PAGE: 03 OF 08



**EMBRAER** EMPRESA BRASILEIRA DE AERONAUTICA S/A - S. JOSÉ DOS CAMPOS - SP

# SERVICE BULLETIN

## MATERIAL

<u>NEW P/N</u>	<u>DESCRIPTION</u>	<u>OLD P/N</u>	<u>QTY</u>	<u>DISP</u>
110-500-10-00-01	Interconnect tube	-	01	2
110-500-10-00-06	Shim	-	01	2
110-500-10-00-04	Elevator control rod	4A-500-10-09	02	3
AN3-6A	Bolt	AN3-4A	02	7
AN3-6A	Bolt	-	06	2
AN3-7A	Bolt	-	02	2
H14-3	Nut	-	06	2
H14-3	Nut	H14-3	02	7
AN960D10	Washer	AN960-D10	08	7
AN960-10L	Washer	-	08	2
AN960-10L	Washer	AN960-10L	02	7
MS35336-43	Lock washer	MS35336-43	04	7
MS24665-136	Cotter pin	MS24665-136	04	7

- DISPOSITION:
- 2 = Incorporate part bearing NEW P/N.
  - 3 = Replace part bearing OLD P/N with part bearing NEW P/N.
  - 7 = Replace with part bearing the same P/N.



EMBRAER

EMPRESA BRASILEIRA DE AERONAUTICA S/A - S. JOSÉ DOS CAMPOS - SP

# SERVICE BULLETIN

THIS PAGE LEFT BLANK INTENTIONALLY

DATE: 25 / Sep / 81

S.B. NO. 110-27-056 7.  
PAGE: 03 of 06



# SERVICE BULLETIN

- ① Access to Ut elevator control rod ends.
- ② Access to the elevator control arms.
- ③ Replace elevator control rod P/N 4A-500-10-09 with part P/N 110-500-10-00-04. Reuse hardware and install new cotter pins, MS24665-136.  
When removing old control rod, maintain dimension "A" unchanged, transferring it to the new rod, so as to facilitate system rigging. Ascertain that dimension "A" is the same on both rods in order to prevent the rods from being overloaded. Using the elevator neutral position locking device as per T.O. 1095A-2-5, section III, check that left and right elevators are aligned. Install bonding strap terminal as shown in detail "F".
- ④ Position the interconnect tube between the elevator actuating arms, maintaining the 81 mm dimension (see detail "E"). Coincide the interconnect tube centerline with the elevator actuating arm centerline and transfer the 5.5 mm interconnect tube flange holes to the actuating arms. Should distance between actuating arms prevent the interconnect tube positioning even if shim P/N 110-500-10-00-06 is not used, mill tube flanges in order to reduce its length. The minimum thickness of each interconnect tube flange should be 4 mm.
- ⑤ Install interconnect tube PA; 110-500-10-00-05 and the shim P/N 110-500-10-00-06 (if necessary) between the actuating arms, attaching them with AN3-6A bolts, H14-3 nuts and AN960-10L washers (3 positions per each actuating arm).  
Shim PA; 110-500-10-00-06 is made of calibrated sheet metal and the proper thickness to eliminate the gap must be obtained during assembly. It is important to determine the correct thickness so as to prevent actuating arms from flexing when the assembly is mounted.  
Install bonding scrap terminal on the elevator actuating arm, attaching it together with interconnect tube assembly as shown in detail "F".

FIGURE 1 - ELEVATOR ACTUATING ARMS INTERCONNECTION AND CONTROL RODS REPLACEMENT (SHEET 1 OF 3)

SR. Nº. 110-27-056  
PAGE 06 of 08

DATE: 25 / sep / 81  
CHANGE Nº. — / — / — / — / —

8.



EMBRAER

EMPRESA BRASILEIRA DE AERONAUTICA S/A - S. JOSÉ DOS CAMPOS - SP

# SERVICE BULLETIN

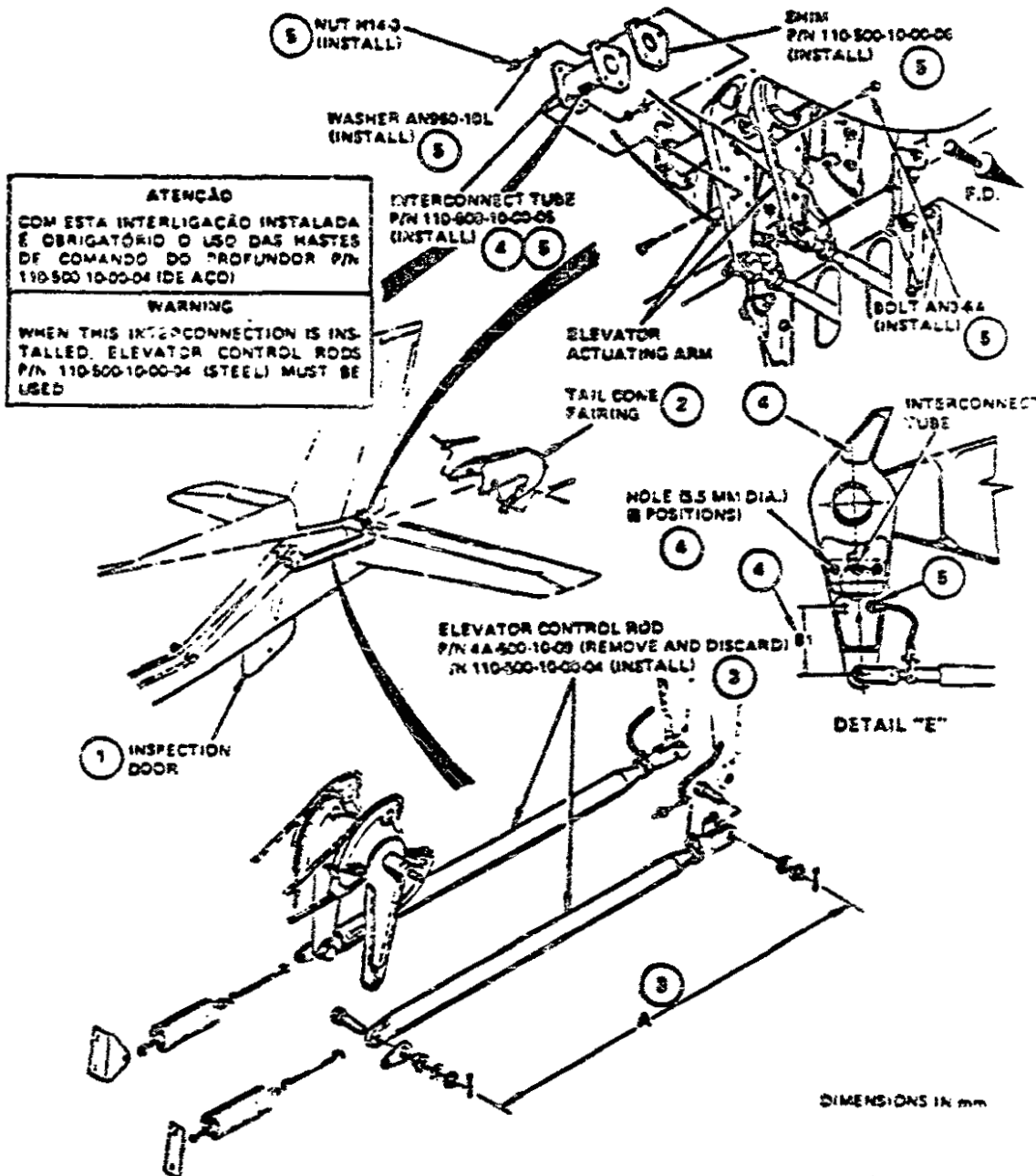

FIGURE 1 - ELEVATOR ACTUATING ARMS INTERCONNECTION AND CONTROL RODS REPLACEMENT (SHEET 2 OF 3)

DATE: 25 Sep 81

S.S. Nº. 110-27-056 9.



EMBRAER

EMPRESA BRASILEIRA DE AERONAUTICA S/A - S. JOSE DOS CAMPOS - SP

# SERVICE BULLETIN

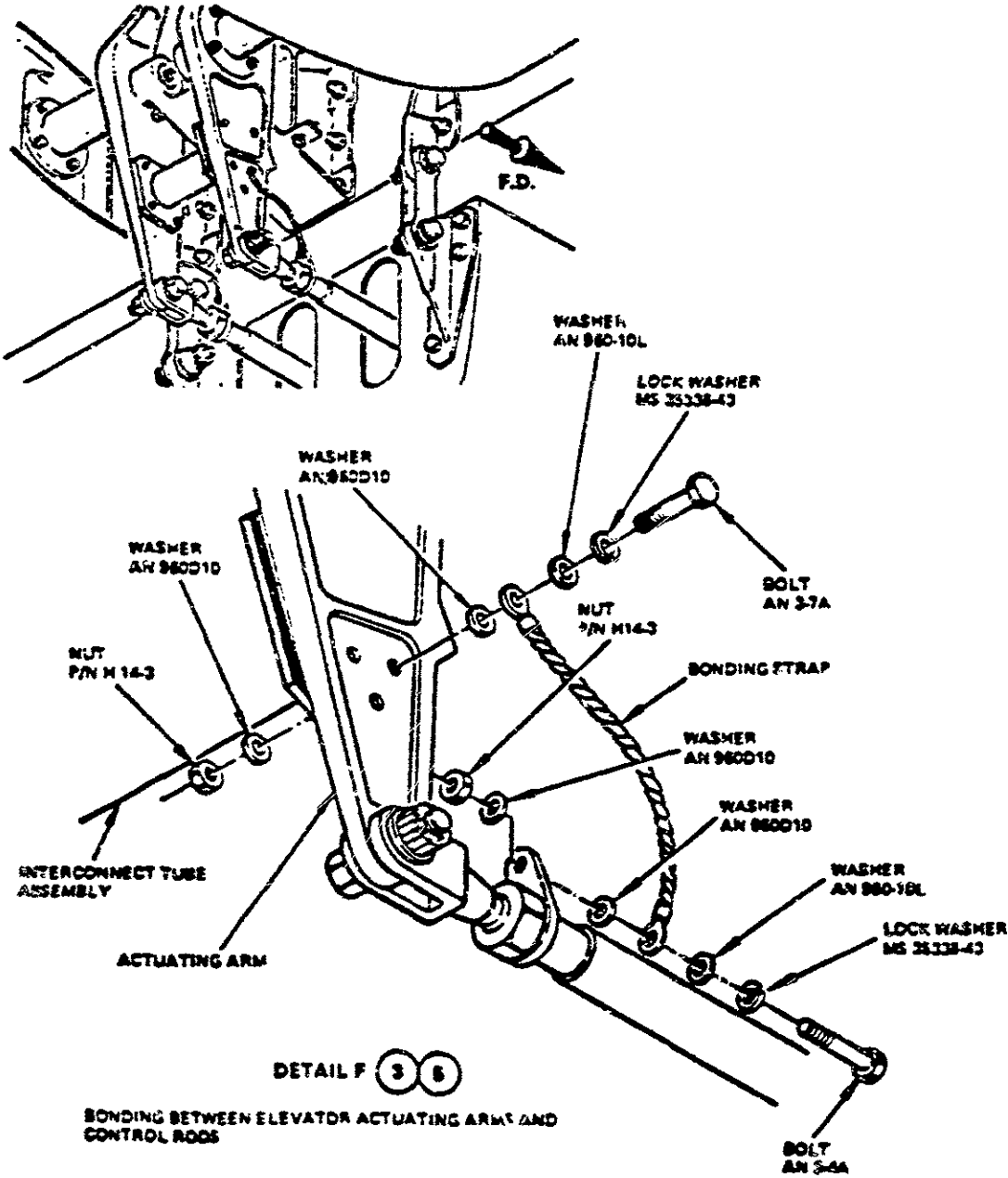

FIGURE 1 - ELEVATOR ACTUATING ARMS INTERCONNECTION AND CONTROL RODS REPLACEMENT (SHEET 3 OF 3)

S.B. Nº. 110-27-056

DATE: 25 Sep 81

10.



**← EMBRAER** EMPRESA BRASILEIRA DE AERONÁUTICA S/A - S. JOSÉ DOS CAMPOS - SP

# SERVICE BULLETIN

PLIGHT CONTROLS - REPLACEMENT OF THE ELEVATOR CONTROL RODS  
(E.O. 110-092702)

## 1. PLANNING INFORMATION

### 1.1 EFFECTIVITY

Aircraft affected:



MODEL	S/N
EMB-110( ) BANDEIRANTE, all models.	110001 thru 110322. 110324 thru 110341, 110343. 110345 thru 110350, 110353, 110354, 110356 thru 110358, 110360 thru 110362, 110364 thru 110366. 110375, 110376 which have accomplished neither SB 110-27-056 nor SB 110-55-022.

In-production effectivity:

Aircraft S/N 110323, 110342, 110344, 110353. 110352, 110355. 110359.  
110363, 110367 thru 110374. 110377 and on and aircraft that have  
accomplished S.B. 110-27-056 and/or S.B. 110-55-022 are already equipped  
with a steel tube rod assembly.

### 1.2 REASON

Instances of corrosion have been detected on the elevator control rod  
tube, on the adjustable end side.

### 1.3 DESCRIPTION

Part I of this bulletin recommends the visual inspection for the  
evidence of corrosion. eventually causing cracks or swelling, at the  
Sips of the elevator control Pod tubes.  
Embraer strongly recommends the accomplishment of inspection covered in  
Part I of this bulletin, within the next 50 operating hours or 10 days.

DATE 08 / Jan / 85

S.S. Nº. 110-27-076 11  
PAGE 01 of 02

**← EMBRAER** EMPRESA BRASILEIRA DE AERONÁUTICA S/A - S. JOSÉ DOS CAMPOS - SP

# SERVICE BULLETIN

whichever occurs first. Should no discrepancy be detected, this inspection must be repeated at every 125 operating hours or one month, whichever comes first, until Part II of this bulletin is accomplished. Should any discrepancy be found, Part II of this bulletin must be accomplished as a final action.

Access to the work area is gained through the tail cone access windows.

Part II of this bulletin instructs on the replacement of the aluminum alloy tubes (which make up the elevator actuating rod assemblies), with new steel tubes.

Therefore, on disassembly, each rod end must be inspected for corrosion to determine whether it is reusable or not.

If check reveals that one of the rod ends cannot be reused, this will dictate the need for replacing the actuating rod assembly.

Part II of this bulletin must be accomplished within the next 500 operating hours or 3 months, whichever comes first, or when any discrepancy is evidenced during the inspections described in Part I. The access to the work area is obtained through the bellcrank inspection windows and through the tail cone fairing.

## 1.4 APPROVAL

CTA/IFI - Vice-Direção de Homologação e Padrões.

## 1.5 MANPOWER

Part I : Approximately, 0,5 man-hour.

Part II: Approximately, 10 man-hours.

← EMBRAER EMPRESA BRASILEIRA DE AERONÁUTICA S/A - S. JOSÉ DOS CAMPOS - SP

# SERVICE BULLETIN

## 1.6 MATERIAL

The material required for accomplishment of Part II of this bulletin will be available from EMBRAER on a non-charge basis.

NOTE: Sealants PR1431G and PR1221B 1/2, rivets KS20613-SP20, and lockwire MS20995C41 should be procurable from the operator's inventories.

## 1.7 TOOLING

Not applicable.

## 1.8 WEIGHT AND BALANCE

Not affected.

## 1.9 REFERENCES

- T.O. 1C95A-3 - "Structural Repair Manual".
- T.O. 1C95A-2-2 - "Maintenance Manual - Ground Handling, Servicing and Airframe Maintenance".
- T.O. 1C95A-2-5 - "Maintenance Manual - Flight Controls".
- T.O. 1EMB110P( )-4-5 - "Illustrated Parts Breakdown - Flight Controls".

## 1.10 PUBLICATIONS AFFECTED

- T.O. 1EMB110P( )-4-5 - "Illustrated Parts Breakdown - Flight Controls".

DATE 02 / Jan / 85

SA. NO. 110-27-076  
PART. 03 OF 08

**← EMBRAER** EMPRESA BRASILEIRA DE AERONÁUTICA S/A - S. JOSÉ DOS CAMPOS - SP

# SERVICE BULLETIN

## 2. ACCOMPLISHMENT INSTRUCTIONS

The steps below provide general accomplishment instructions. Detailed instructions are given as notes in the figures.

### 2.1 PART I: Inspection for corrosion.

- 2.1.1 Gain recess to the terminals through the tail cone inspection windows.
- 2.1.2 Inspect for corrosion, that may be possibly leading to cracks and swelling to the ends of the rod tubes, mainly in the riveted area, within a length of 50 mm.
- 2.1.3 Should any anomaly be found, proceed as per Part II of this bulletin.
- 2.1.4 Otherwise, restore aircraft to normal.
- 2.1.5 Enter the accomplishment of Part I of this bulletin in the applicable document.

### 2.2 PART II: Replacement of elevator control rod tubes.

- 2.2.1 Lock the elevator in its neutral position, as per T.O. 1095A-2.5 - "Maintenance Knurl - Flight Controls".
- 2.2.2 Gain access to the work area through the elevator bellcrank inspection door and by removing the tail cone fairing.
- 2.2.3 Disconnect the elevator bellcrank springs.

S.B. Nº. 110-27-076

DATE: 08 / Jan / 85

14.

← EMBRAER EMPRESA BRASILEIRA DE AERONÁUTICA S/A - S. JOSÉ DOS CAMPOS - SP

# SERVICE BULLETIN

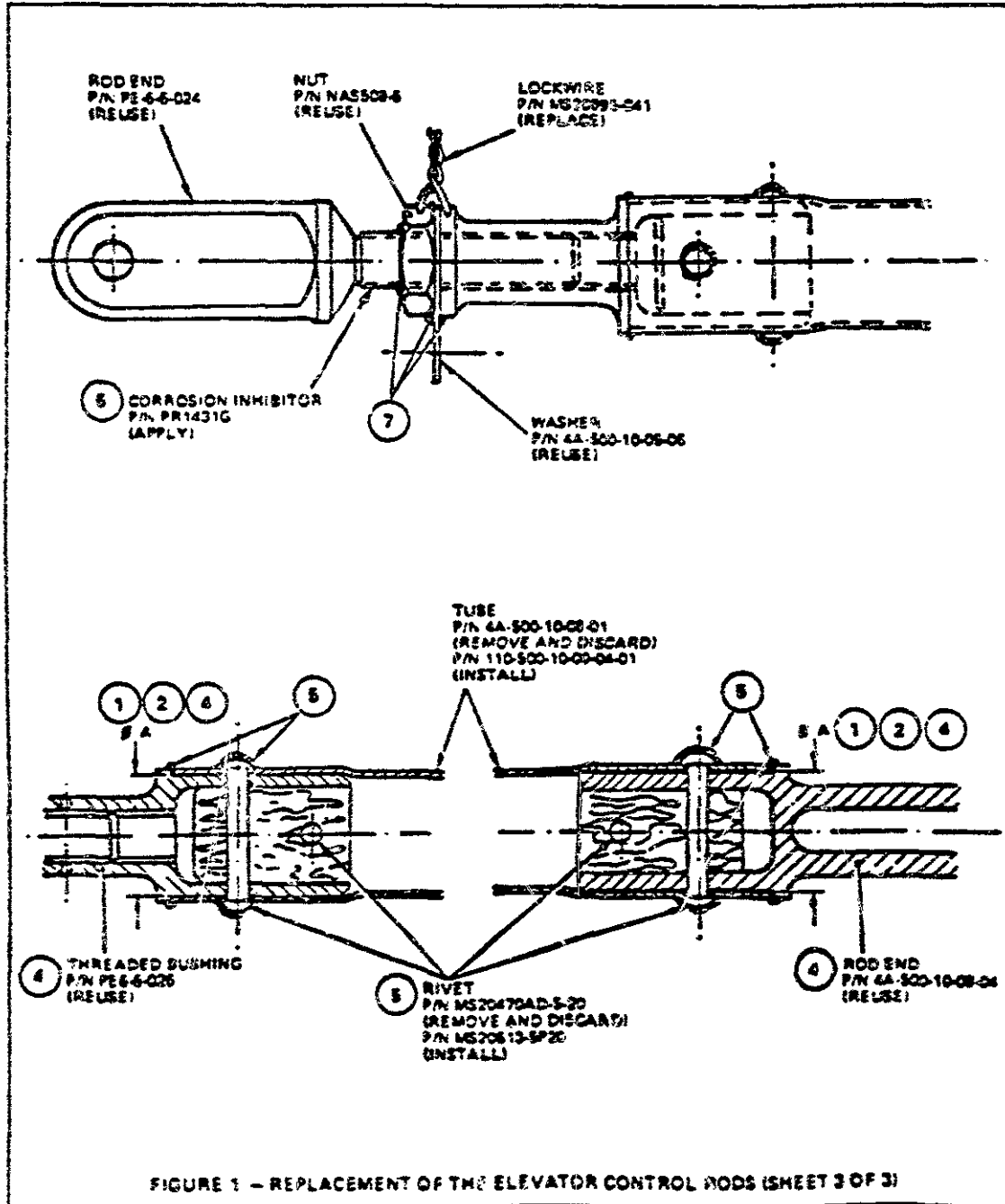

SB No 110-27-076

DATE 08 Jan 85

14a.

# SERVICE BULLETIN

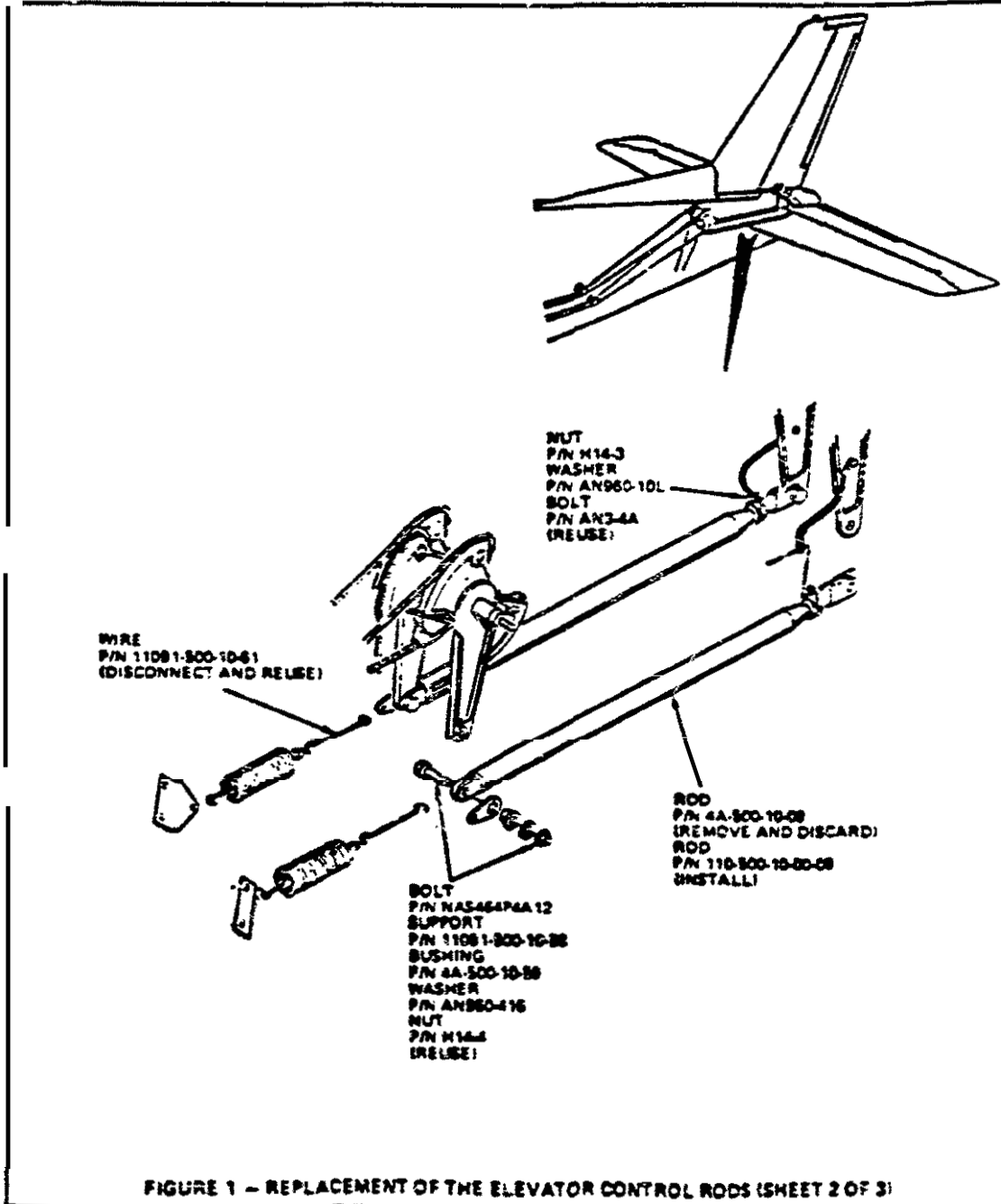

DATE 08 Jan 85

SS Nº 310-27-076 <sup>14E</sup>  
PAGE 07 of 08

# SERVICE BULLETIN

2.2.4 Remove, rework and install *the* rods as per figure 1.

NOTE: Replace the rods, one at a time, with the two elevators locked, so as to ensure that the new rod length be adjusted by the length of the existing rod.

2.2.3 Install the springs of the elevator bellcranks.

2.2.6 Restore aircraft to normal.

2.2.7 Enter the accomplishment of Part II of this bulletin in the applicable documents.

### 3. MATERIAL

<u>NEW PIN</u>	<u>DESCRIPTION</u>	<u>OLD P/N</u>	<u>QTY</u>	<u>DISP</u>
110-500-10-00-09	Rod	4A-500-10-09	2	4/1
110-500-10-00-04-01	Tube	4A-500-10-09-01	2	5/2
MS20613-5P20	Rivet	MS20470-AD5-20	4	5/2
PR1221B 1/2	Sealant	-	AR	5
PR1431G	Sealant	-	AR	6
MS20995C41	Lockwire	MS20995C41	AR	6/7

- DISPOSITION:
- 1 = Reidentify part bearing OLD P/N.
  - 2 = Incorporate part bearing NEW P/N.
  - 4 = Rework OLD P/N.
  - 5 = Discard part bearing OLD P/N.
  - 6 = Apply as required.
  - 7 = Replace with part bearing the same P/N.

DATE 08 / Jan / 65

SB NO: 110-27-076 15.  
PAGE: 05 of 06

**← EMBRAER** EMPRESA BRASILEIRA DE AERONÁUTICA S/A - S. JOSÉ DOS CAMPOS - SP

# SERVICE BULLETIN

- ① Check for presence of corrosion on diameter A of the rod end and of the threaded bushing.
- ② Should corrosion be found, sand the spot 0.1 mm, maximum.
- ③ If corrosion persists, replace the assembly with New P/N 110-500-10-00-09.
- ④ If corrosion has been eliminated, replace the tube and install rod end and threaded bushing, applying sealant PR1431G all over diameter A.
- ⑤ Install rivets totally impregnated with sealant PR1221B 1/2, using the existing rivet holes or drilling new holes in a position relocated to 90 degrees from the formerly existing holes, and apply alodine to the aluminum rod end holes as per T.O. 1C95A-3 - "Structural Repair knurl". Apply sealant PR1221B 1/2 onto rivet heads and tube ends.
- ⑥ Apply corrosion inhibiting sealant PR1431G all over the terminal thread, with the nut positioned at the end of the thread.
- ⑦ Apply sealant PR1221B 1/2 onto washer, nut, and terminal.

FIGURE 1 - REPLACEMENT OF THE ELEVATOR CONTROL RODS  
(SHEET 1 OF 3)

S.B. NO. 110-27-076  
DATE 08 Jan 85

DATE: 08 Jan 85 **16.**  
CHANGE NO.



← **EMBRAER** EMPRESA BRASILEIRA DE AERONAUTICA S/A - R. JOSE DOS CAMPOS - SP

# SERVICE BULLETIN

## FUSELAGE - INSPECTION OF THE FUSELAGE STRUCTURE NEAR THE HORIZONTAL STABILIZER FRONT ATTACHMENT (E.O. 110-081301)

### 1. PLANNING INFORMATION

#### 1.1 EFFECTIVITY

Aircraft affected:

<u>MODEL</u>	<u>S/N</u>
EMB-110( ) BANDEIRANTE	110001 thru 110386, 110388 thru 110397, 110399 thru 110401, 110404 thru 110408, 110410 thru 110412, 110414, 110415 and 110421.

In-production effectivity:

Aircraft EMB-110( ) BANDEIRANTE S/N 110387, 110398, 110402, 110403, 110409, 110413, 110416 thru 110420, 110422 and on have an equivalent modification factory-incorporated.

#### 1.2 REASON

Investigation on some aircraft has revealed the slackening of fuselage riveting near the horizontal stabilizer front attachment. Some aircraft additionally presented cracks in the web of bulkhead 33. Since the flight hours logged ranged from 1800 to 8000, no safe limit could be established for preventive inspection. Consequently, an urgent action is required to assure the integrity of the horizontal stabilizer structural attachment.

#### 1.3 DESCRIPTION

A visual inspection is strongly recommended within the next 50 operating hours to check for the integrity of the structure riveting near the horizontal stabilizer front attachment fitting and for cracks in the web of bulkhead 33, LH and RH sides.

DATE: 29 / Mar / 83

S.S. Nº: 110-53-019  
PAGE: 01 of 24

← **EMBRAER** EMPRESA BRASILEIRA DE AERONAUTICA S/A - E. JOSÉ DOS CAMPOS - SP

# SERVICE BULLETIN

4.0 man-hours for the modification as per figure 4 (for both sides).

7.0 man-hours for the modification as per figures 4 and 5 (for both sides).

5.0 man-hours, if required, for removing the stabilizer front attachment fitting.

5.0 man-hours, if required, for installation of the stabilizer front attachment fitting.

4.0 man-hours for adjustment of the control cables tension.

## 1.6 MATERIAL - COST AND AVAILABILITY

The material required for accomplishment of this bulletin will be available from EMBRAER upon receipt of orders, at no charge.

1.6.1 The Kits listed below should be procurable from *the* operator's inventories and is applicable to the modification of the horizontal stabilizer front attachment structure riveting (either LH or RH side of the aircraft) as per figure 3.

<u>P/N</u>	<u>DESCRIPTION</u>	<u>QTY</u>
NAS1097AD4-5	Rivet	40
NAS1097AD5-7	Rivet	04
NAS1097AD5-6	Rivet	06
MS20470AD4-6	Rivet	08

DATE: 29 / Mar / 83  
 CHANGE NO: 01 / 13 / Apr / 84

S.B. NO: 210-53-019  
 PAGE: 03 of 24

← EMBRAER EMPRESA BRASILEIRA DE AERONAUTICA S/A - R. JOSE DOS CAMPOS - SP

# SERVICE BULLETIN

<u>P/N</u>	<u>DESCRIPTION</u>	<u>QTY</u>
HL22-77-5-4	<u>Hi-lok Rivet</u>	10
or	or	or
AN3-5A	<u>Bolt</u>	10
and	and	and
AN960-10	Washer	10
and	and	and
H14-3 or MS21042L3	Locknut	10

1.6.3 Kit 02 - Applicable to the introduction of the reinforcing channel (RH side of the aircraft) as per figure 4.

<u>P/N</u>	<u>DESCRIPTION</u>	<u>QTY</u>
110-1411-07-30-04	Reinforcing Channel	01
110-1411-07-30-09	Reinforcement between Frame 32 and Bulkhead 33	01
110-1411-07-30-10	Reinforcement between Frame 32 and Bulkhead 33	01

The other material required and listed below should be available from the operator's inventories.

<u>P/N</u>	<u>DESCRIPTION</u>	<u>QTY</u>
NAS1097AD4-5	Rivet	4
MS20470AD4-5	Rivet	38
NAS1097AD5-7	Rivet	04
NAS1097AD5-5	Rivet	11
MS20470AD4-6	Rivet	06
MS20470AD5-6	Rivet	12
HL22-77-5-4	<u>Hi-lok Rivet</u>	10
or	or	or
AN3-5A	<u>Bolt</u>	10
and	and	and
AN960-10	Washer	10
and	and	and
H14-3 or MS21042L3	Locknut	10

DATE: 29 / MAR / 83  
 CHANGE NO: 02 - 13 / APR / 84

SERIAL: 110-53-019  
 PAGE: 05 of 24

← **EMBRAER** EMPRESA BRASILEIRA DE AERONAUTICA S/A - S. JOSÉ DOS CAMPOS - SP

## SERVICE BULLETIN

1.6.4 Kit 03 - Applicable to the repair of bulkhead 33 web and to the introduction of the reinforcing channel (LH side of the aircraft) as per figures 4 and 5.

<u>P/N</u>	<u>DESCRIPTION</u>	<u>QTY</u>
110-1411-07-30-01	Reinforcing Channel	01
110-1411-07-30-02	Bulkhead 33 Reinforcement	01
110-1411-07-30-03	Bulkhead 33 Repair Sheet	01
110-1411-07-30-07	Reinforcement between Frame 32 and Bulkhead 33	01
110-1411-07-30-08	Reinforcement between Frame 32 and Bulkhead 33	01

The other material listed below should be available from the operator's inventories.

<u>P/R</u>	<u>DESCRIPTION</u>	<u>QTY</u>
NAS1097AD4-5	Rivet	45
MS20470AD4-5	Rivet	62
NAS1097AD5-7	Rivet	04
NAS1097AD5-6	Rivet	11
MS20470AD4-6	Rivet	06
MS20470AD5-6	Rivet	12
MS20470AD4-4	Rivet	04
HL22-77-5-4	Hi-lok Rivet	15
or	or	or
AN3-5A	Bolt	15
and	and	and
AN950-10	Washer	15
and	and	and
H14-3 or MS21042L3	Locknut	15

S.S. N°: 110-53-019

PAGE: 06 / 24

DATE: 29 / Mar / 83

CHANGE N°: 02 / 13 / APR / 84

← EMBRAER EMPRESA BRASILEIRA DE AERONAUTICA S/A - R. JOSE DOS CAMPOS - SP

# SERVICE BULLETIN

1.6.5 Kit 04 - Applicable to the repair of bulkhead 33 and to the introduction of the reinforcing channel (RH side of the aircraft) as per figures 4 and E.

<u>P/N</u>	<u>DESCRIPTION</u>	<u>QTY</u>
110-1411-07-30-04	Reinforcing Channel	01
110-1411-07-30-05	Bulkhead 33 Reinforcement	01
110-1411-07-30-06	Bulkhead 33 Repair Inset	01
110-1411-07-30-09	Reinforcement between Frame 32 and Bulkhead 33	01
110-1411-07-30-10	Reinforcement between Frame 32 and Bulkhead 33	01

The other material listed below should be available from the operator's inventories.

<u>P/N</u>	<u>DESCRIPTION</u>	<u>QTY</u>
NAS1097AD4-5	Rivet	45
MS20470AD4-5	Rivet	42
NAS1097AD5-7	Rivet	04
NAS1097AD5-6	Rivet	11
MS20470AD4-6	Rivet	06
MS20470AD5-6	Rivet	12
MS20470AD4-4	Rivet	04
HL22-77-5-4	Hi-lok Rivet	15
or	or	or
AN3-5A	Bolt	15
and	and	and
AN960-10	Washer	15
and	and	and
H14-3 or MS21042L3	Locknut	15

DATE: 29 / MAY / 83

S.S. NO. 110-53-019  
PAGE: 07 of 24

← **EMBRAER** EMPRESA BRASILEIRA DE AERONAUTICA S/A - E. JOSE DOS CAMPOS - SP

# SERVICE BULLETIN

1.6.6 Kit 05 - Applicable to the reinstallation of the stabilizer front attachment fitting as per figure 5.

<u>P/N</u>	<u>DESCRIPTION</u>	<u>QTY</u>
NAS6205-9	Bolt	08
MS21042-15	Nut	08
AN960-516L	Washer	16
NAS6204-6	Bolt	04
M14-4	Nut	04
AN980-416	Washer	04
HL22-77-5-3	Rivet	32
HL22-77-5-4	Rivet	14
HL22-77-6-6	Rivet	20
HL22-77-6-7	Rivet	06

## 1.7 TOOLING - COST AND AVAILABILITY

Not applicable.

## 1.8 WEIGHT AND BALANCE

<u>KIT</u>	<u>WEIGHT CHANGE</u>	<u>MOMENT CHANGE</u>
3.1	+ 0.024 kgf	+ 0.135 kgf.m
3.2	+ 0.134 kgf	+ 1.75 kgf.m
3.3	+ 0.134 kgf	+ 1.75 kgf.m
3.4	+ 0.157 kgf	+ 2.06 kgf.m
3.5	+ 0.157 kgf	+ 2.06 kgf.m
3.6	no alteration	no alteration

NOTE: The items presented above refer to the material listed in paragraph 3 "Material".

## 1.9 REFERENCES

T.O. 1095A-2-5 "Maintenance Manual - Flight Controls".

S.A. Nº: 110-33-019

PAGE: 08 of 24

DATE: 29 / Mar / 83

CHANGE Nº: 02 - 13 / Apr / 84

← EMBRAER EMPRESA BRASILEIRA DE AERONAUTICA S/A. R. JOSE DOS CAMPOS - SP

# ~~SERVE~~ BULLETIN

T.O. 1C95-3 "Structural Repair Manual".

## 1.10 PUBLICATIONS AFFECTED

Not affected.

## 2. ACCOMPLISHMENT INSTRUCTIONS

NOTE: The steps below outline the general instructions for the accomplishment of this bulletin. Detailed sequence of operations is given as notes in the figures.

- 2.1 Gain access to the affected area through the inspection window on the tail cone. If required, release the autopilot servo control cables and remove the seats and floor between frame 14 and bulkhead 16, in order to release the elevator and rudder control cables.
- 2.2 Visually check for integrity of structure riveting near the horizontal stabilizer front attachment fitting and for cracks in the web of bulkhead 33, at positions shown in figure 1.
- 2.3 Check figure 1 to make sure which actions are required.
- 2.4 Restore the aircraft to normal.
- 2.5 Carry out an operational check-out of the elevator and rudder control systems, as per T.O. 1C95A-2-5 "Maintenance Manual - Flight Controls".
- 2.6 Enter the accomplishment of this bulletin in the applicable document.

DATE: 29 / Mar / 83  
CHANGE NO. 02 / 13 / APT / 84

S.S. NO. 110-53-019  
PAGE: 09 of 24

← **EMBRAER** EMPRESA BRASILEIRA DE AERONAUTICA S/A - S. JOSÉ DOS CAMPOS - SP

# SERVICE BULLETIN

## 3. MATERIAL

3.1 Material applicable to the modification of the horizontal stabilizer front attachment structure riveting as per figure 3. (Applicable to the LH and RH sides of the aircraft).

<u>NEW P/N</u>	<u>DESCRIPTION</u>	<u>OLD P/N</u>	<u>QTY</u>	<u>DISP</u>
MS20470AD4-6	Rivet	-	06	2
NAS1097AD4-5	Rivet	-	40	2
NAS1097AD5-7	Rivet	-	04	2
NAS1097AD5-5	Rivet	-	10	2
HL22-77-5-4	Hi-Tack Rivet	-	10	2
or	or	or	or	or
AN3-5A	Bolt	-	10	2
and	and		and	and
AN950-10L	Washer	-	10	2
and	and		and	and
H14-3 or MS2104ZL3	Locknut	-	10	2

3.2 Material applicable to the Introduction of the reinforcing channel (Xlt 01 - LH side of the aircraft) as per figure 4.

<u>NEW P/N</u>	<u>DESCRIPTION</u>	<u>OLD P/N</u>	<u>QTY</u>	<u>DISP</u>
110-1411-07-30-01	Reinforcing Channel	-	01	2
110-1411-07-30-07	Reinforcement between Frame 32 and Bulkhead 33	4A-1419-07	01	3/5
110-1411-07-30-08	Reinforcement between Frame 32 and Bulkhead 33	4A-1419-05	01	3/5
NAS1097AD4-5	Rivet	-	45	2
MS20470AD4-5	Rivet	-	38	2

S.B. Nº: 110-53-019  
PAGE: 10 of 24

DATE: 29 / MAR / 83  
CHANGE Nº: 02 / 13 / APR / 84



← **EMBRAER** EMPRESA BRASILEIRA DE AERONAUTICA S/A - S. JOSE DOS CAMPOS - SP

# SERVICE BULLETIN

<u>NEW P/N</u>	<u>DESCRIPTION</u>	<u>OLD P/N</u>	<u>QTY</u>	<u>DISP</u>
NAS1097AD5-7	Rivet	-	04	2
NAS1097AD5-8	Rivet	-	11	2
MS20470AD4-5	Rivet	-	06	2
MS20470AD5-5	Rivet	-	12	2
HL22-77-5-4	Hi-lok Rivet	-	10	2
or	or		or	or
AN3-5A	Bolt	-	10	2
and	and		and	and
AN960-10L	Washer	-	10	2
and	and		and	and
H14-3 or MS21042L3	Locknut	-	10	2

3.3 Material applicable to the introduction of the reinforcing channel (Kit 52 - RH side of the aircraft) as per figure 4.

<u>NEW P/N</u>	<u>DESCRIPTION</u>	<u>OLD P/N</u>	<u>QTY</u>	<u>DISP</u>
110-1411-07-30-04	Reinforcing Channel	-	01	2
110-1411-07-30-09	Reinforcement between Frame 32 and Bulkhead 33	4A-1419-08	01	3f5
110-1411-07-30-10	Reinforcement between Frame 32 and Bulkhead 33	4A-1419-06	01	3/5
NAS1097AD4-5	Rivet	-	45	2
MS20470AD4-5	Rivet	-	38	2
NAS1097AD5-7	Rivet	-	04	2
NAS1097AD5-6	Rivet	-	11	2
MS20470AD4-6	Rivet	-	06	2
MS20470AD5-6	Rivet	-	12	2
HL22-77-5-4	Hi-lok Rivet	-	10	2
or	or		or	or
AN3-5A	Bolt	-	10	2
and	and		and	and
AN960-10L	Washer	-	10	2
and	and		and	and
H14-3 or MS21042L3	Locknut	-	10	2

DATE: 29 / MAY / 83

SERIAL: 110-33-019

PAGE: 11 of 24

← **EMBRAER** EMPRESA BRASILEIRA DE AERONAUTICA S/A - S. JOSÉ DOS CAMPOS - SP

# SERVICE BULLETIN

3.4 Material applicable to the repair of bulkhead 33 web and the introduction of the reinforcing channel (Kit 03 - LH side of the aircraft) as per figures 3 and 4.

<u>NEW P/N</u>	<u>DESCRIPTION</u>	<u>OLD P/N</u>	<u>QTY</u>	<u>DISP</u>
110-1411-07-30-01	Reinforcing Channel	-	01	2
110-1411-07-30-02	Bulkhead 33 Reinforcement	-	01	2
110-1411-07-30-03	Bulkhead 33 Repair Sheet	-	01	2
110-1411-07-30-07	Reinforcement between Frame 32 and Bulkhead 33	4A-1419-07	01	3/5
110-1411-07-30-08	Reinforcement between Frame 32 and Bulkhead 33	4A-1419-05	01	3/5
NAS1097AD4-5	Rivet	-	45	2
MS20470AD4-5	Rivet	-	42	2
NAS1097AD5-7	Rivet	-	04	2
NAS1097AD5-5	Rivet	-	11	2
MS20470AD4-6	Rivet	-	06	2
MS20470AD5-6	Rivet	-	12	2
MS20470AD4-4	Rivet	-	04	2
HL22-77-5-4	Hi-lok Rivet	-	15	2
or	OR		or	or
AN3-5A	Bolt	-	15	2
and	and		and	and
AN960-10	Washer	-	15	2
and	and		and	and
H14-3 or MS21042-3	Locknut	-	15	2

3.5 Material applicable to the repair of bulkhead 33 web and the introduction of the reinforcing channel (Kit 04 - RH side of the aircraft) as per figures 4 and 5.

S.S. Nº. 110-53-019  
PAGE: 12 of 26

DATE: 29 / MAR / 83  
CHANGE Nº. 02 - 19 / APR / 84

← **EMBRAER** EMPRESA BRASILEIRA DE AERONÁUTICA S/A - E JOSÉ DOS CAMPOS - SP

# SERVICE BULLETIN

<u>NEW P/N</u>	<u>DESCRIPTION</u>	<u>OLD P/N</u>	<u>QTY</u>	<u>DISP</u>
110-1411-07-30-04	Reinforcing Channel	-	01	2
110-1411-07-30-05	Bulkhead 33 Reinforcement	-	01	2
110-1411-07-30-06	Bulkhead 33 Repair Sheat	-	01	2
110-1411-07-30-09	Reinforcement between Frame 32 and Bulkhead 33	4A-1419-08	a	3/5
110-1411-07-30-10	Reinforcement between Frame 32 and Bulkhead 33	4A-1419-06	01	3/5
NAS1097AD4-5	Rivet	-	45	2
MS20470AD4-5	Rivet	-	42	2
NAS1097AD5-7	Rivet	-	04	a
NAS1097AD5-6	Rivet	-	11	2
MS20470AD4-6	Rivet	-	06	2
MS20470AD5-6	Rivet	-	12	2
MS20470AD4-4	Rivet	-	04	2
ML22-77-5-4	Hi-lok Rivet	-	15	2
or	or	or	or	or
AN3-5A	Bolt	-	15	2
and	and	and	and	and
AN960-10L	Washer	-	15	2
and	and	and	and	and
H14-3 or MS21042L3	Locknut	-	15	2

3.6 Reinstallation of the horizontal stabilizer front attachment fitting (Kit 05), as per figure 5.

<u>NEW P/N</u>	<u>DESCRIPTION</u>	<u>OLD P/N</u>	<u>QTY</u>	<u>DISP</u>
NASA6205-9	Bolt	NASA6205-9	06	7
MS21042-L5	Nut	MS21042-L5	06	7
AN960-516L	Washer	AN960-516L	26	7
NASA6204-6	Bolt	NASA6204-6	04	7

DATE: 29 / May / 83

S.S. NO. 110-53-019

← **EMBRAER** EMPRESA BRASILEIRA DE AERONAUTICA S/A - S. JOSE DOS CAMPOS - SP

# SERVICE BULLETIN

<u>NEW P/N</u>	<u>DESCRIPTION</u>	<u>OLD P/N</u>	<u>QTY</u>	<u>DISP</u>
H14-6	Nut	H14-4	04	7
AN960-416	Washer	AN960-416	04	7
HL22-77-5-3	Rivet	HL22-77-5-3	32	7
HL22-77-5-4	Rivet	HL22-77-5-4	14	7
HL22-77-6-6	Rivet	HL22-77-6-6	20	7
HL22-77-6-7	Rivet	HL22-77-6-7	06	7

DISPOSITION: 2 = Install part bearing NEW P/N.

3 = Replace part bearing OLD P/N with part bearing NEW P/N.

5 = Discard part bearing OLD P/N.

7 = Replace with part bearing tht same P/N.

S.B. Nº: 110-53-019  
 PAGE: 24 of 24

DATE: 29 / Mar / 83  
 CHANGE Nº: 02 - 13 , 6PT , 84

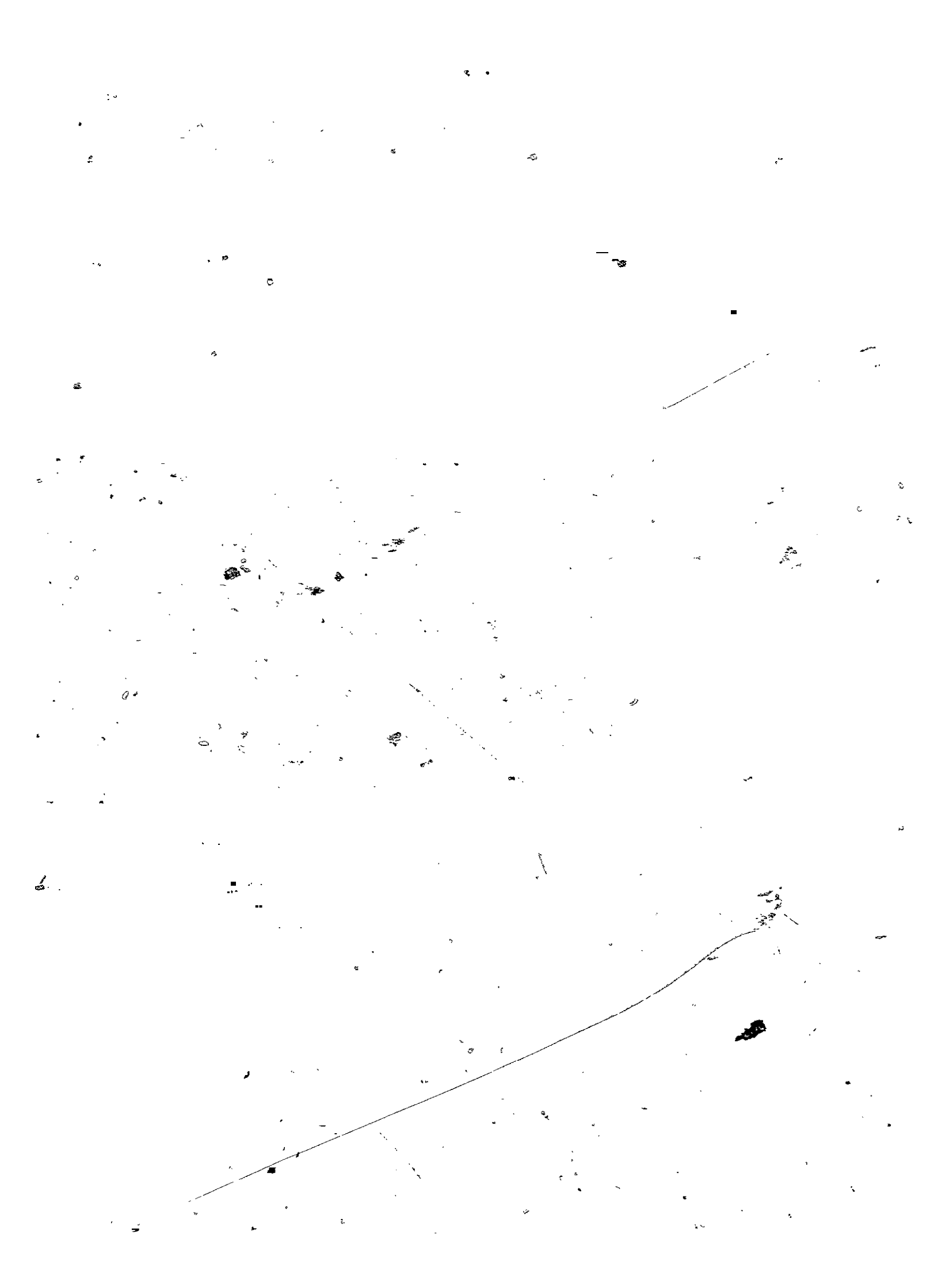

THIS PAGE LEFT BLANK INTENTIONALLY

# SERVICE BULLETIN

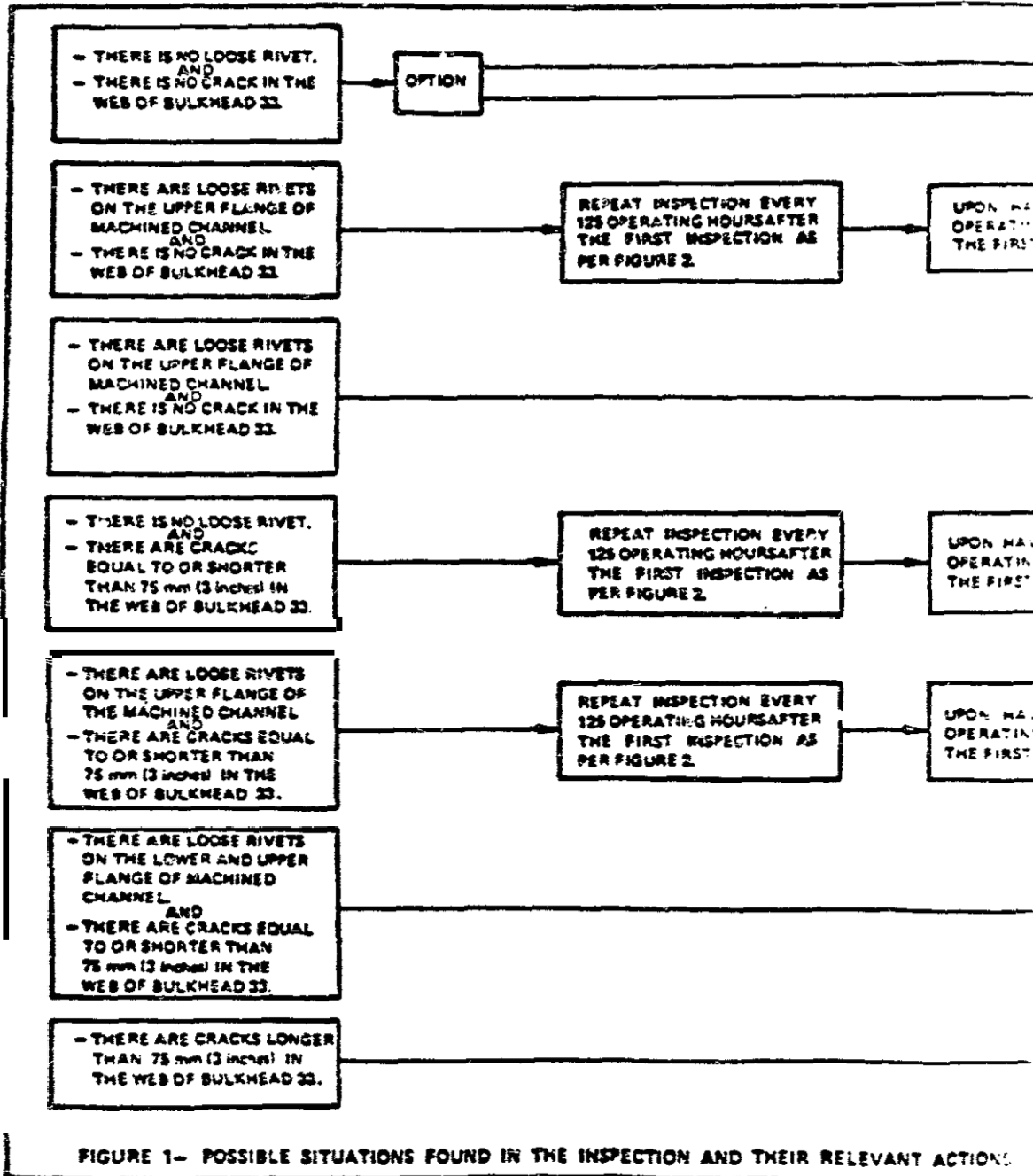

DATE: ... 20 ... / ... / ... 83

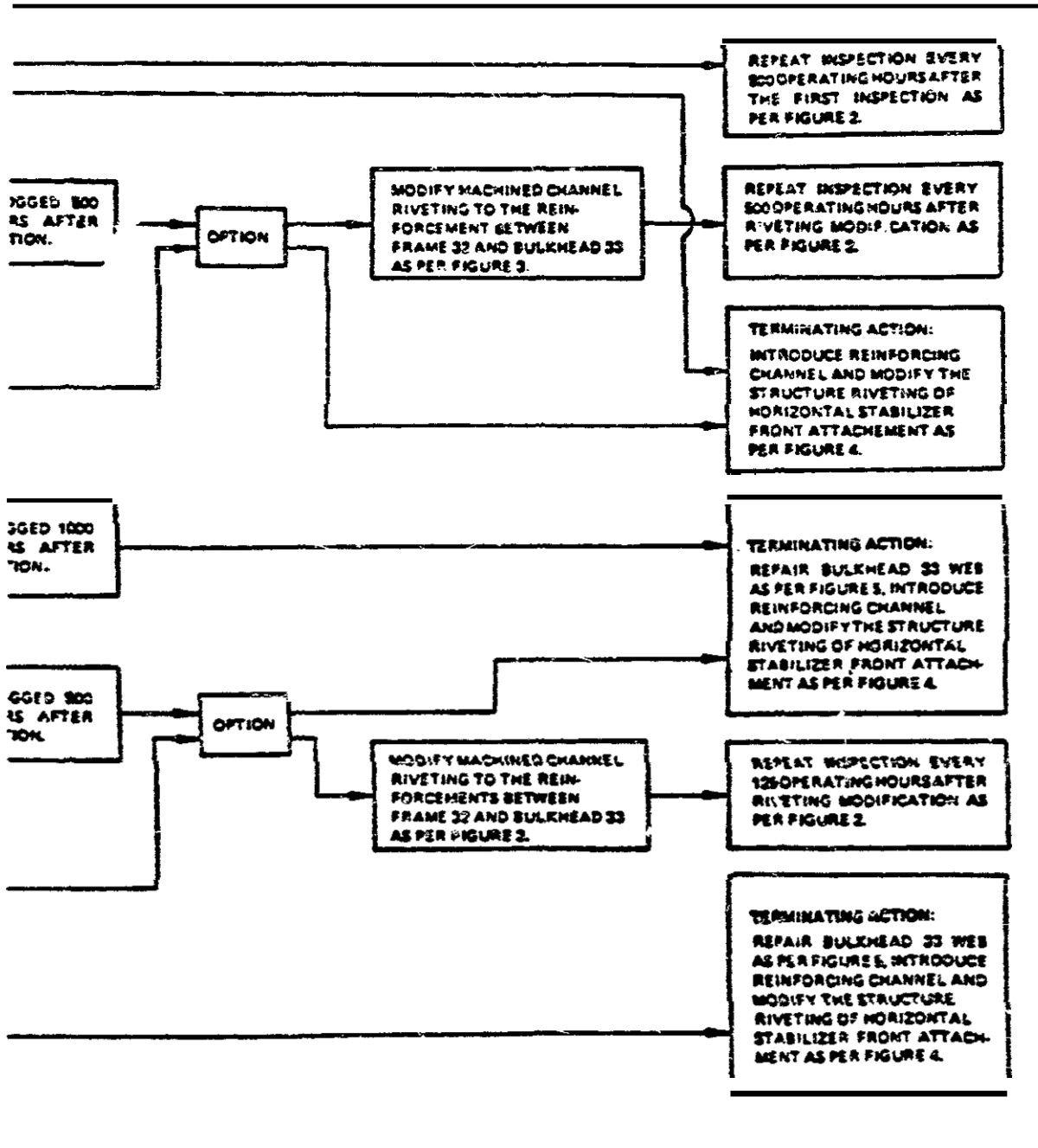



# SERVICE BULLETIN

- ① Check this rivet row for loose rivets.
- ② Inspect hatched area for cracks.

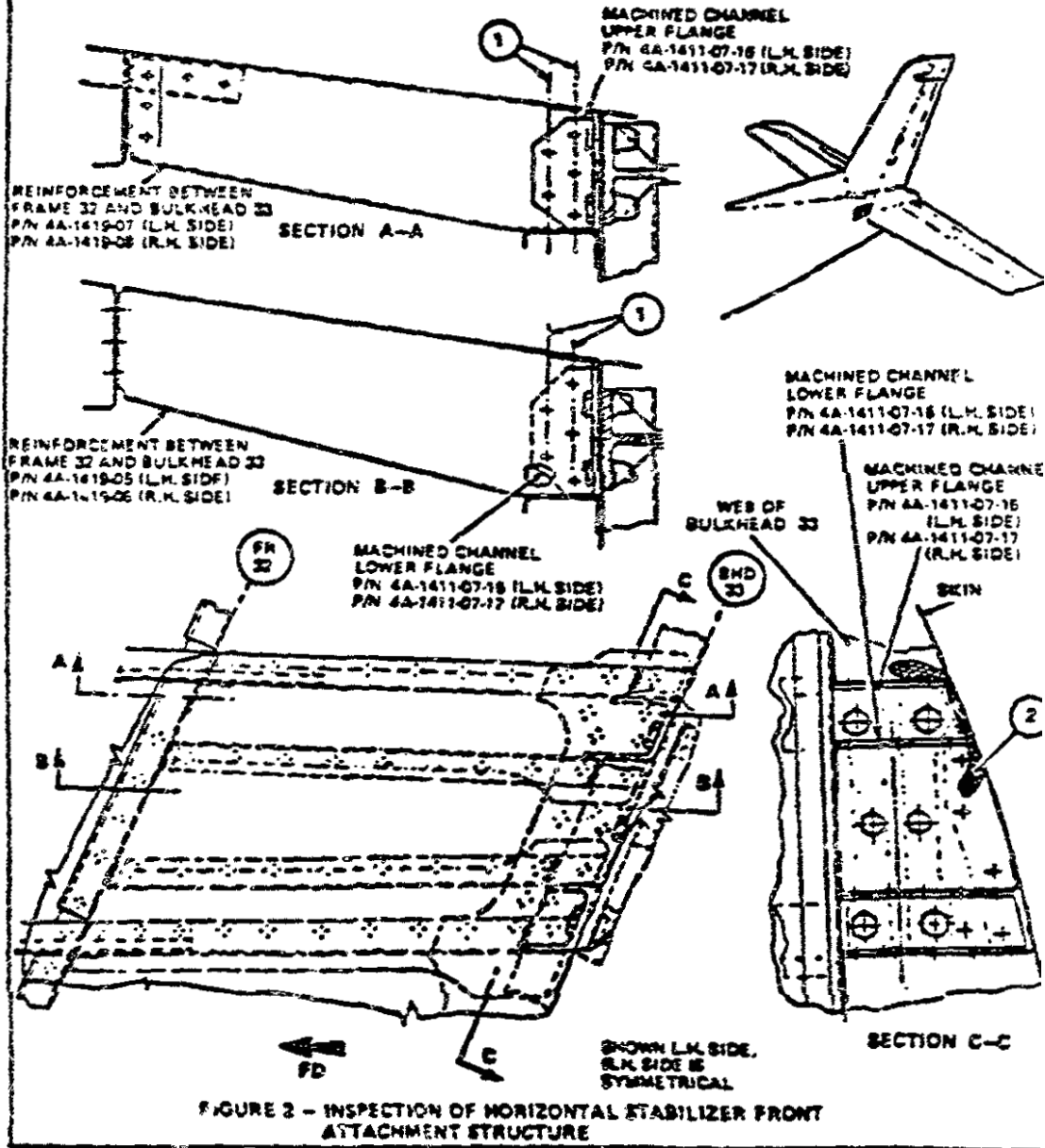

DATE 29 / MAY / 83

S.S. NO. 110-53-019

PAGE: 17 of 24

EMBRAER EMPRESA BRASILEIRA DE AERONAUTICA S.A.

# SERVICE BULLETIN

① Replace existing rivets with other bearing ~~no~~ specification, or bolts, washers and lockwashers ~~with~~ channel with it removed from the aircraft.

② Replace rivets loosen with other bearing ~~no~~

③ Ream holes to dia $\phi$	4.153	mm	(	.1635	"	---
	4.204			.2635		
rivets or to dia $\phi$	4.813	mm	(	.125	"	---
	4.864			.191		

bolts.

FIGURE 3 - MODIFICATION OF STABILIZER FRONT

# SERVICE BULLETIN

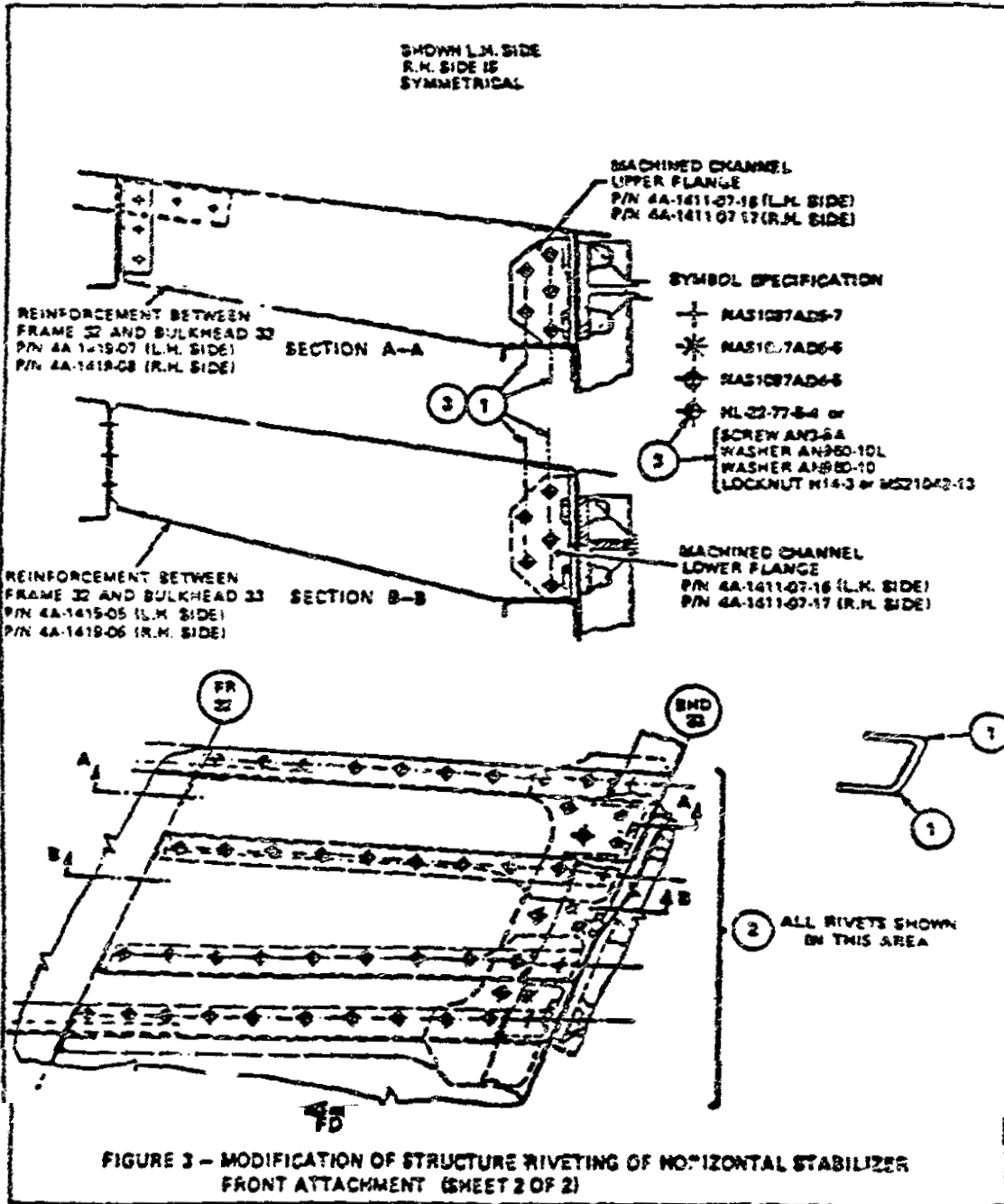

DATE: 29 / MAY / 83  
CHANGE NO. 02 - 13 / APT. 84

CS. NO. 110-53-019  
PAGE: 19 of 24

← EMBRAER EMPRESA BRASILEIRA DE AERONAUTICA S/A - S. JOSÉ DOS CAMPOS - SP

# SERVICE BULLETIN

- ① Unrivot this rivet row and remove fitting attaching bolts, remove reinforcements (made of sheet) together with the machined channel.
- ② Unrivot machined channel from reinforcements (made of sheet). Discard reinforcements (made of sheet).
- ③ Round corners of machined channel.
- ④ Assembly the machined channel with the new reinforcements (made of sheet) and with the reinforcing channel, by using rivets bearing new specification.

⑤ Ream holes to dia  $\varnothing$   $\begin{matrix} 4.153 \\ 4.204 \end{matrix}$  mm  $\left( \begin{matrix} .1635 \\ .1635 \end{matrix} \right)$  in ) if using

rivets or to dia  $\varnothing$   $\begin{matrix} 4.813 \\ 4.864 \end{matrix}$  mm  $\left( \begin{matrix} .189 \\ .191 \end{matrix} \right)$  in ) if using

bolts.

- ⑥ Reinstall the assembly previously assembled as per note ④ riveting up with rivets bearing new specification and install fitting attaching bolts.
- ⑦ Replace existing rivets with rivets bearing new specification.

FIGURE 4 - INTRODUCTION OF THE REINFORCING CHANNEL AND MODIFICATION OF RIVETING OF HORIZONTAL STABILIZER FRONT ATTACHMENT (SHEET 1 OF 2)

S.S. Nº: 110-53-019  
PAGE: 20 of 24

DATE: 29 / MAR / 83  
CHANGE Nº: 02 / 13 / APR / 84

← EMBRAER EMPRESA BRASILEIRA DE AERONÁUTICA S/A - S. JOSÉ DOS CAMPOS - SP

# SERVICE BULLETIN

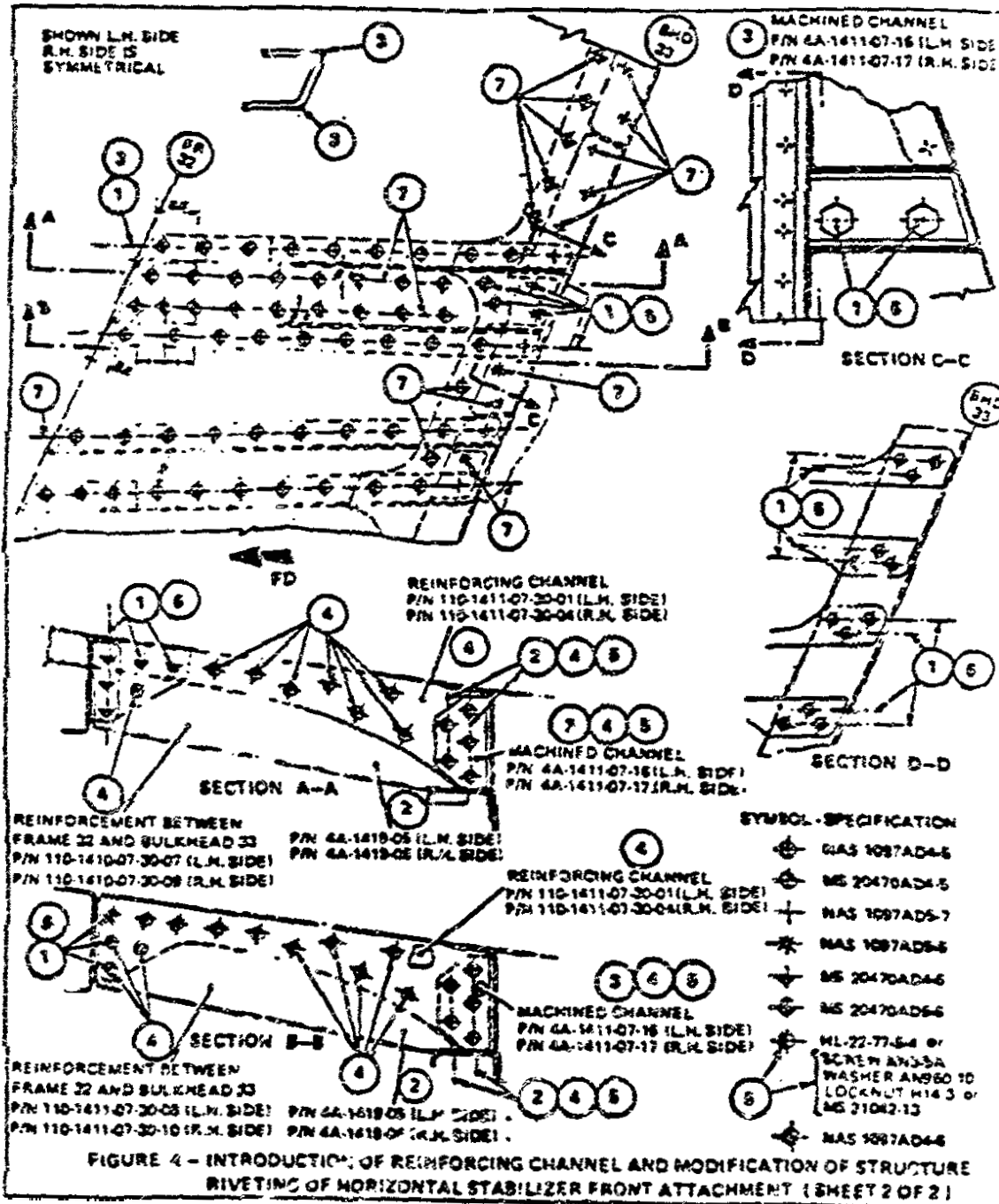

DATE 28 Feb 83

S.B. NO. 110-53-019

PAGE 21 of 24

← EMBRAER EMPRESA BRASILEIRA DE AERONÁUTICA S/A - S. JOSÉ DOS CAMPOS. SP

# SERVICE BULLETIN

- ① Remove the horizontal stabilizer front attachment fitting.
- ② Cut out the web of bulkhead 33. Contour repair sheet as per cut out in bulkhead 33 web.
- ③ Position, mark and drill repair sheet and bulkhead 33 reinforcement as per holes existing on the horizontal stabilizer front attachment.
- ④ Mark and drill as shown.
- ⑤ Reinstall the fitting removed in ① (see detail C).  
If required, use oversized rivets, according to instructions in T.O. 1C95-3 "Structural Repair Manual".
- ⑥ Use rivets according to symbols.

FIGURE 5 - REPAIR OF BULKHEAD 33 WEB (SHEET 1 OF 2)

S.E. Nº: 110-53-019  
PAGE: 22 of 24

DATE: 26 / Mar / 83  
CHANGE Nº: 02 - 13 / APR / 84

← EMBRAER EMPRESA BRASILEIRA DE AERONÁUTICA S/A - S. JOSÉ DOS CAMPOS - SP

# SERVICE BULLETIN

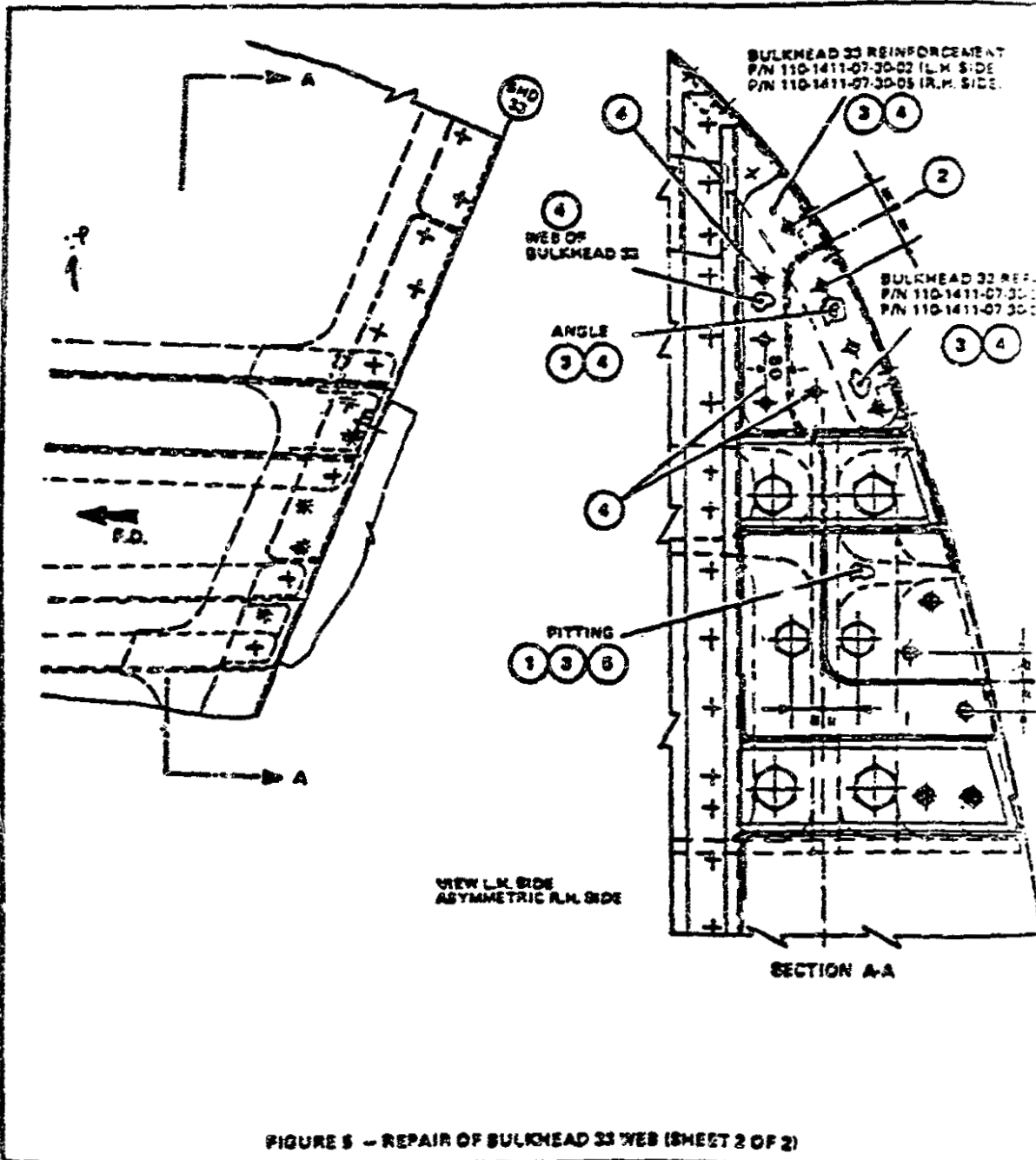

FIGURE 5 - REPAIR OF BULKHEAD 33 WEB (SHEET 2 OF 2)

DATE: 29 / MAY / 83

APPENDIX F

TABLE I

PARAMETER LIST (FIXED WING AIRCRAFT)

<u>PARAMETERS</u>	<u>RANGE</u>	<u>INSTALLED SYSTEM 1/ MINIMUM ACCURACY (TO RECOVERED DATA)</u>	<u>SAMPLING INTERVAL (PER SECOND)</u>
Relative time (from recorder on prior to takeoff)	8 hro. minimum	$\pm 0.125\%$ per hour	1
Indicated Airspeed	$V_{SO}$ to $V_D$ (KIAS)	+5% or +10 kts., whichever $T_s$ greater. Resolution 2 kts. below 175 KIAS	1
Altitude	-1,000 ft. to max cert. alt. of A/C	+100 to +700 ft. (see Table 1, TSO C51-a)	1
Magnetic Heading	360°	$\pm 5^\circ$	1
Vertical Acceleration	-3g to +6g	+0.2g In addition to $\pm 0.3g$ maximum datum error	4 (or 1 per second where peaks ref. to 1g are recorded)
Longitudinal Acceleration	$\pm 1.0g$	+0.05g In addition to max. datum error of $\pm 0.1g$	2
Pitch Attitude	100% of usable range	$\pm 2^\circ$	1
Roll Attitude	+60° or 100% of usable range, whichever is greater	$\pm 2^\circ$	1
Stabilizer Trim Position OR Pitch Control Position	Full range	$\pm 3\%$ unless higher accuracy uniquely required	1
	Full range	$\pm 3\%$ unless higher accuracy uniquely required	1

1/ When data sources are aircraft instruments (except altimeters) of acceptable quality to fly the aircraft, the recording system excluding these sensors (but including all other characteristics of the recording system) shall contribute no more than half the values in this column.



TABLE I (2)

Engine Power, Each Engine

Fan or N <sub>1</sub> Speed or EPR or Cockpit Indicationr Used for Aircraft Certification	Maximum range	+5%	1
OR Prop. Speed and Torqw (Sampled Once/Sec as Close Together as Practicable)			1 (prop speed) 1 (torque)
Altitude Rate (need depends on altitude resolution)	+8,000 fpm	+10%. Resolution 250 fpm below 12,000 ft. indicated	1
Angle of Attack 2/ (need depends on altitude resolution)	-200 to +40 <sup>0</sup> or 100% of usable range	±2 <sup>0</sup>	1
Radio Transmitter Keying (Discrete)	On/Off		1
TE Flaps (Discrete or Analog)	Each discrete position (U,D,T/O,APP) OR Analog 0-100% range	+3 <sup>0</sup>	1
LE Flaps (Discrete or or Analog)	Each discrete position (U,D,T/O,APP) OR Analog 0-100% range	+3 <sup>0</sup>	1
Thrust Reverser, Each Engine (Discrete)	Stowed or full reverse		1
Spoiler/Speedbrake (Discrete)	Stowed or out		1
Autopilot Engaged (Discrete)	Engaged or Disengaged		1

2/ If data from the altitude encoding altimeter (100 ft. resolution) is used, then either one of these parameters should also be recorded. If, however, rltitude is recorded at a minimum resolution of 25 feet, than these two parameters can be omitted.

APPENDIX F

-98-

PB86-910409



**NATIONAL  
TRANSPORTATION  
SAFETY  
BOARD**

WASHINGTON, D.C. 20594

**AIRCRAFT ACCIDENT REPORT**

**HENSON AIRLINES FLIGHT 1517  
BEECH B99, N339HA  
GROTTOES, VIRGINIA  
SEPTEMBER 23, 1985**

**NTSB/AAR-86/07**

**UNITED STATES GOVERNMENT**

