

Chapter 8: Fuel-less Engines

We have been raised with the idea that it is necessary to burn a fuel to produce power which we can use. We are sold coal, coke, timber, paraffin/kerosene, petrol/gasoline, diesel, propane, etc. for us to burn in order to “get” energy. While it is perfectly true that burning these things will indeed result in energy in a form which we find convenient to use in heating, cooling, powering engines, etc. what is carefully avoided is the fact that it is not at all necessary to burn a fuel in order to run the things which we want to power. This ‘inconvenient’ fact has been concealed and denied for more than fifty years now (very surprisingly, by the people who want to sell us these fuels to burn – do you perhaps think that they may have some motive for this, other than our best interests about which they are no doubt, very concerned?).

This chapter is about ‘fuel-less’ motors. Strictly speaking, they are not self-powered but as they don’t burn a fuel of any kind, in everyday language they can be described as ‘self-powered’. In the same way that a solar panel in sunlight uses no fuel and yet puts out electrical power, these motors draw energy from the environment and provide us with mechanical power. In actual fact, power is never “used up” but just converted from one form into another. In the case of our trusty solar panel, some 17% of the radiation from the sun (mainly ultraviolet) is **converted** into electrical power and 83% goes in heating and other losses, but as we don’t have to supply the sunlight, and the solar panel pours out the electricity which we want without us having to do anything to make it happen, we really don’t care very much about its extremely low efficiency. As far as we are concerned, the electricity flowing from the panel is “free-energy”.

It is really amazing that we have been persuaded that we must burn a fuel in order to get power. Take the case of a heavy-displacement sailing yacht. The skipper can voyage using his inboard diesel engine:



This matches perfectly with the thinking that you need to burn a fuel in order to get power as the yacht is moving along, pushed by the engine which is powered by burning diesel fuel. But, what if the skipper decides to switch the engine off and set the sails?:



Now, the same boat, weighing exactly the same with the same crew, is now continuing the voyage at the same speed, but no fuel is being burnt. The really interesting thing is that while we know this perfectly well, and we are aware that people have sailed right around the world in boats which do not have engines, it does not seem to occur to us that this shows conclusively that it is not necessary to burn a fuel to power some item of equipment or form of transport.

In the case of our yacht, the energy comes from the sun which heats the atmosphere unevenly, causing winds to blow and the yachtsman uses the sails to make those winds power his boat through the water. So, a sailing boat is actually powered by the sun although we don't usually think about it that way.

There are many hydro-electric "power stations" where electricity is 'generated' by machines driven by water pressure. In actual fact, no power is 'generated' at all, but instead, the potential energy of the body of water is **converted** into electricity by having the water fall and spin the shaft of a machine. So, how did the water get up there in the first place? Well, it came from rain. And how did the rain get up there? It rose up there due to evaporation caused by the heat of the sun. So, the bottom line again is that hydro-electric 'power' stations are powered by the sun.

Windmills are also powered by the sun. But, and here is the really interesting thing, if I state that it is perfectly possible for a compressed-air engine to produce mechanical power with burning any fuel, then there is an immediate and strong reaction where people will say "Impossible – that is perpetual motion !!" They imply that perpetual motion is impossible but never supply any rational evidence to support that implication. The Earth has been spinning on its axis for millions of years, so when exactly do they expect it to stop? All the planets in the Solar System have been orbiting for millions of years, how long do they have to orbit before they can be considered to be in perpetual motion? Why then are people so opposed to the idea of perpetual motion? Presumably, because perpetual motion shows clearly that a fuel does not have to be burned to 'produce' power and that would not be good for people who sell fuels, and so, we are all told from an early age that perpetual motion is "impossible".

Well, that does not matter here as we are going to look at compressed-air engines which run off the heat of the sun. That is, they are heat-pumps which are a well accepted engineering fact and they work on wholly accepted standard scientific principles. An ordinary refrigerator outputs three or four times as much heat power as the electrical power driving it, and it could be twice that efficient if it were used properly. This is a Coefficient Of Performance (COP) of 3 or 4, which is supposed to be "impossible" but unfortunately, all refrigerators work like this and you can't exactly say that refrigerators don't exist, just because their performance does not appear to fit in with some theories.

Actually, there is no magic involved here as the extra energy is being drawn from the heat content of the air in the immediate locality. The refrigerator is not operating in isolation and there is a heat exchange with the air surrounding it. This outside energy causes the COP>1 performance. In passing, all COP>1 devices operate by drawing energy in from an external source (usually the zero-point energy field) and none of them actually break the 'rules' of science. But, enough of that.

The people who don't want self-powered engines used in the world today, pin their hopes on a continued ignorance of Engineering facts relating to heat pumps. A self-sustaining compressed-air engine is actually running off power from the sun just as sailboats, windmills and hydro-electric power stations do. Sorry folks, no magic here, just bog-standard Engineering. Admittedly, very few people know or realise the implications of this standard Engineering:

1. All work done in compressing air into a storage tank is converted into heat and then lost to the atmosphere, so the energy in the compressed air inside the tank is the same as that produced by atmospheric heating of that air, but as more of it is now in the tank, there is additional potential for work to be done. This extra energy was fed into the air by atmospheric heating before the air was compressed.

The First Law of Thermodynamics states that where heat is converted into mechanical energy, or mechanical energy is converted into heat, the quantity of heat is exactly equivalent to the amount of mechanical energy. We then have the intriguing situation where all of the mechanical energy put into compressing air into a storage tank is lost as heat, and yet, the tank contents now has a higher potential for doing work. This information comes from Engineering textbooks.

2. If the expanded cold air leaving the engine is used to cool the intake air of the compressor, then there will be an added gain when it warms up inside the cylinder, pulling heat in from the local environment.

3. If the heat of compression is transferred to the air container feeding the engine and not given time to dissipate, then there is a further power gain for the engine.

4. If compressed air is allowed to expand rapidly, there is a marked drop in temperature. The Leroy Rogers engine design, shown later in this chapter, uses this fact to create air-conditioning for a car driven by a compressed-air engine.

OK then, in broad outline, the energy available from a tank of compressed air comes directly from the heat contained in the atmosphere, in spite of the fact that we always imagine that the energy in the tank was put there by our energetic pumping.

Let's check this out by taking a look at some of the engines which use these principle to provide fuel-less operation, starting with the design of Bob Neal. The full patent for Bob's design is included in the Appendix.

Bob Neal's Compressed Air Engine.

Bob Neal's design is a compressed-air operated engine and compressor where the operation of the engine keeps re-supplying the compressed air tank:

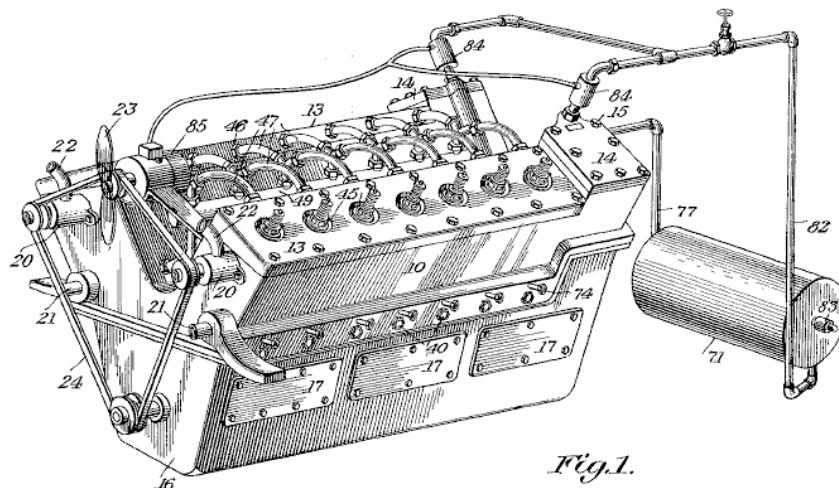

This is a perspective view of the engine and this:

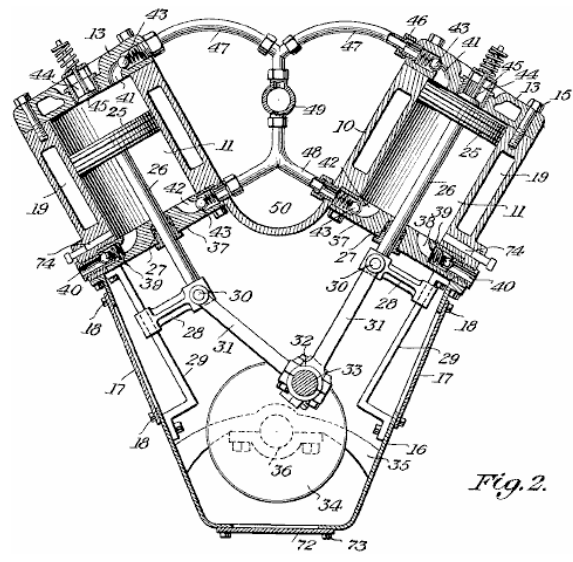
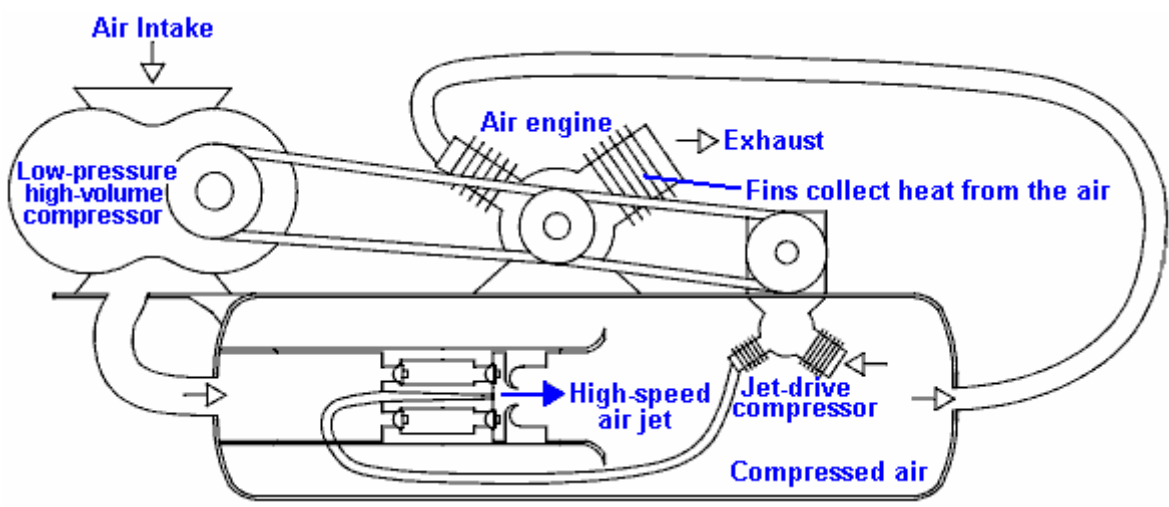

Fig. 2.

is a vertical transverse cross-section view through the compressor part of the engine. In his patent, Bob has avoided any direct mention of the fact that his engine design is fuel-less. That sort of statement is not popular with Patent Examiners even if it is perfectly true.

Scott Robertson's Compressor System.

Bob Neal's system could do with some further explanation, so here is an idea from Scott Robertson whose web site is <http://www.aircaraccess.com/index.htm>, for a possible working compressor system using a leaf-blower:



While this looks rather complicated, in reality it really isn't. Let's take the different sections in order:

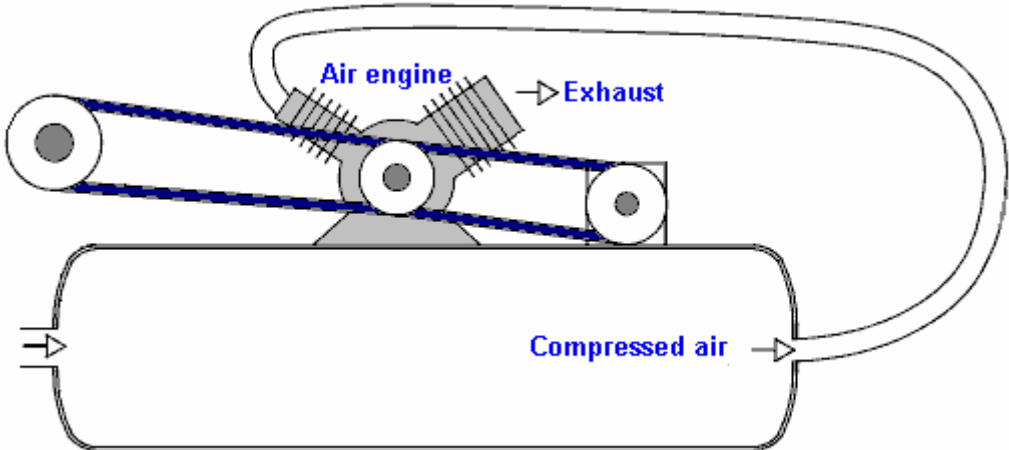

First, you have an ordinary air engine, supplied with compressed air from a pressure tank. This engine exhausts its (cold, expanded) air to the atmosphere. The engine powers two compressors which between them keep the tank full of compressed air.

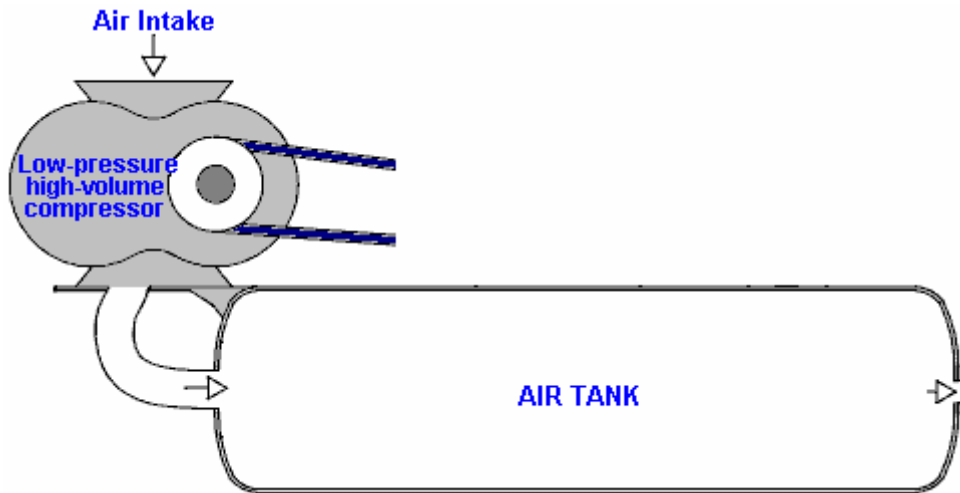

The first compressor is a simple 'leaf-blower' type which produces a large volume of low-pressure air. The big question is "how do you get this large volume of low-pressure air into a tank which has high-pressure compressed air inside it?". Well this seemingly impossible task is performed by the second compressor aided by a cunning, ultra-simple design:

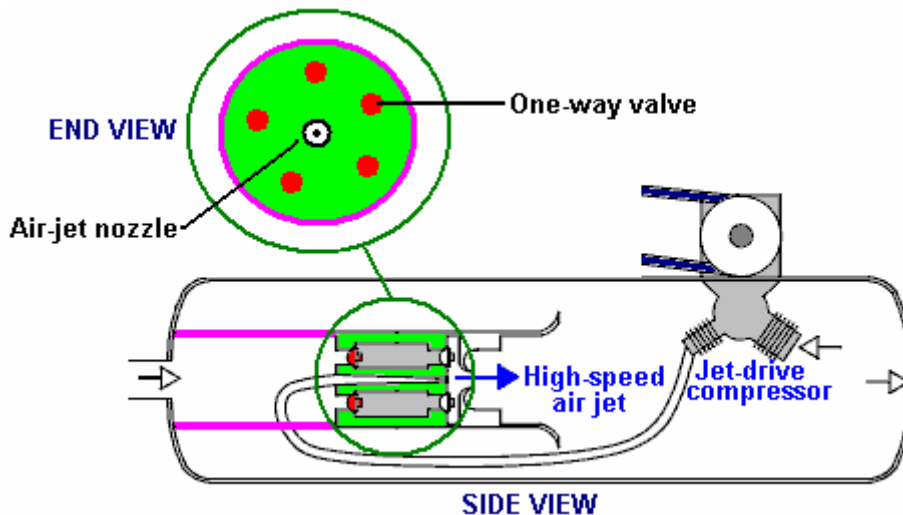

Here, low-pressure air is fed into the low-pressure area marked in pink. Separating it from the high-pressure area is a metal plug marked in green. Set into this plug is a ring of five one-way air valves marked in red. These one-way valves let the low-pressure air into the high-pressure area because of a high-speed jet of air produced by the 'jet-drive compressor'. At first glance, this seems impossible, but it is actually just an application of a standard Engineering technique. The high-speed air jet is directed through a specially shaped nozzle, creating a local low-pressure zone around the jet:

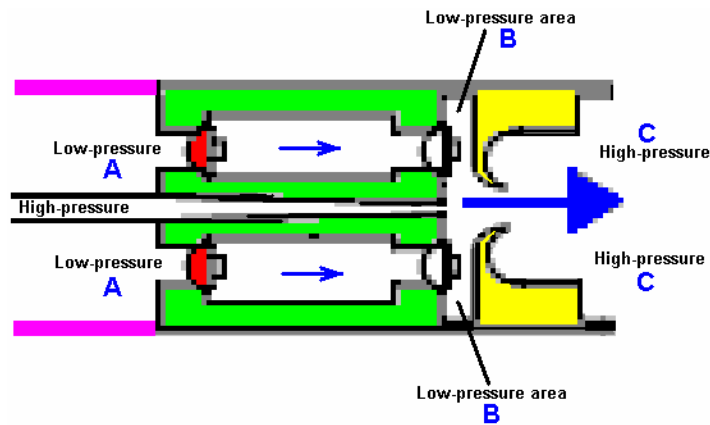

The low-pressure air at point “A” flows through the ring of five one-way valves into the disc-shaped low pressure area “B” and is blasted into the high-pressure area “C” by the high-power air jet ripping through the doughnut-shaped ring marked in yellow. The high-speed air jet causes the low pressure ring “B” by its rapid movement which creates a vortex due to the shape and positioning of the doughnut-shaped ring marked in yellow. This clever arrangement allows large volumes of low-pressure air to be drawn into a tank which contains high-pressure air.

You will also note that the two-stage compressor which generates this high-speed jet of air, has its working area actually inside the tank. This means that the heat of compression is used to heat the air inside the tank and raise its pressure, enhancing the operation further. It should be borne in mind that the new air entering the system has been heated by the sun and contains the energy which powers the system.

The Retro-fit Compressed Air Vehicle System of Leroy Rogers.

The Rogers motor shown here makes no claims to spectacular operation, but in spite of that, Leroy did admit in an interview that this motor does indeed have a greater output than the applied input, provided that the motor is not left just ticking over. This motor is like the US patent 3,744,252 “Closed Motive Power System Utilising Compressed Fluids” by Eber Van Valkinburg shown below. However, the Rogers patent shown here has the distinct advantage that it uses off-the-shelf motors and readily available hardware and there is nothing really exotic or difficult about the Rogers engine that a person couldn’t get from a valve supplier or get a metal fabrication company to construct.

However, while Leroy did state that his design was self-sustaining when going over 30 miles per hour, a key design feature is his very high performance compressor unit which he later patented as shown below. Present day vehicle engines are under-gearred and run at fairly low revs. These same engines operate much more efficiently at higher revs, if they are given different gearing. With the Rogers motor, the air contained in the high-pressure tank is sufficient to drive the pistons up and down. Air can be pumped back into the high-pressure tank by a compressor which has a much higher gearing and much lower capacity per piston stroke. The expanded air exiting from the engine is at much lower temperature than the surrounding air and if it captured in a buffer tank and used as the input of the compressor, then recharging the air tank is more efficient, provided that the tank absorbs heat from the surrounding environment, raising it’s temperature inside the tank and so giving an extra boost to the tank pressure, over and above the compression provided by the compressor.

One really nice feature of Leroy’s design is that he envisages it as being an adaption of an ordinary vehicle engine and he provides a considerable amount of practical detail as to how the adaption can be carried out.

Using a RotoVerter (as described in Chapter 2) to drive a compressor would lower the power requirements of the compressor drive to the extent that a motor adaption of this kind should be self-sustaining. The RotoVerter provides a major energy gain in its own right and is particularly suited to driving mechanical loads such as the compressor and it particularly ‘likes’ constant-load applications such as a compressor.

The adapted engine shown in the patent is like this:

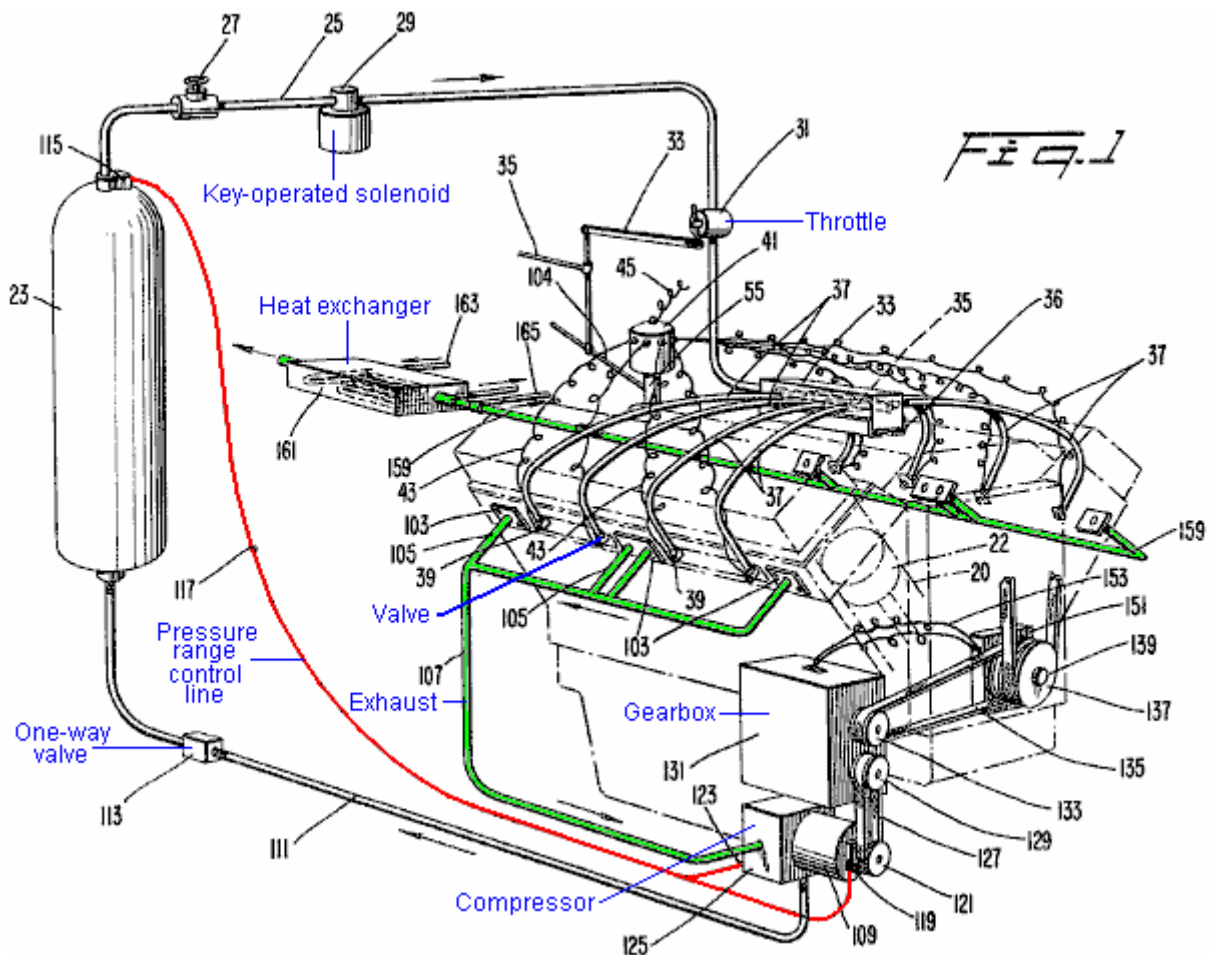

This patent shows how the practical details of running an engine on compressed air can be dealt with. What it does not show is background details of the actual energy flows and the effects of compressing air and then letting it expand. These things are not normally encountered in our daily lives and so we do not have an immediate intuitive feel for how systems like these will operate. Take the effects of expansion. While it is quite well known that letting a compressed gas expand causes cooling, the practical effect is seldom realised.

Leroy's compressor patent is shown here:

United States Patent 4,693,669 Supercharger for automobile engines

Inventor: Rogers Sr., Leroy K. (Rte. 13, P.O. Box 815-DD, Briarcliff Rd., Fort Myers, FL, 33908)

Publication Date: 15th September 1987

Abstract:

A supercharger for delivering supercharged air to an engine, comprising a shrouded axial compressor, a radial compressor which is located downstream of the axial compressor and a housing. The housing is comprised of four sections, including a section which is a highly converging, 'frustoconical' transition duct which favourably directs the discharge of the axial compressor to the inlet of the radial compressor and a hollow, highly convergent, exhaust cone section immediately downstream of the radial compressor which converges into the exhaust port of the supercharger. An annular flow deflector is provided for directing the discharge of the radial compressor into the exhaust cone.

Description:

Superchargers impart additional pressure to the air or the air/fuel mixture of an engine so that the cylinders receive a greater weight per unit volume of air or air/fuel mixture than would otherwise be supplied. As a result, the volumetric efficiency and power output of the engine are improved.

According to prior practices, superchargers generally comprise a single air-blower which forces air or an air/fuel mixture into the cylinders of an engine. Typically, the air-blower is driven by a gear train which is connected to the crankshaft of the engine with a gear ratio of about 6 to 1. These prior types of superchargers have been used extensively in racing engines and radial aircraft engines. However, by reason of their high operating speeds and their gear trains, these superchargers have been considered too complicated, too heavy and too costly for use with mass production engines such as are found in cars and trucks.

Recently, some car manufacturers have been offering turbocharged engines which expand to exhaust gases of the engine through a turbine to drive a centrifugal compressor. Although turbochargers are advantageous in that the turbine can deliver large amounts of power to the compressor, their extreme operating speeds require special bearings, lubrication and maintenance. In addition, turbochargers require special ducting, such as by-pass arrangements, which only add to their cost and maintenance requirements. Consequently, turbochargers are only offered as expensive options in cars.

Further, there is current interest in a new type of car engine which operates from tanks of compressed gas to effect reciprocation of its pistons. An example of such an engine can be found in the U.S. Pat. No. 4,292,804 issued to the same inventor of the present invention. In the referenced patent, at least a portion of the partially expanded exhaust gas from the cylinders is directed to a compressor where it is recompressed and then returned to the storage tanks from whence it originally came. It would be desirable that at least some, if not all of the aforementioned recompression of the exhaust gas could be achieved with a belt-driven, rotary supercharger that is easily manufactured and maintained, yet is capable of providing ample recompression.

Objects of the Invention:

Accordingly, an object of the present invention is to provide a supercharger suitable for improving the performance of engines of cars, helicopters or the like, which supercharger is inexpensive to produce and easy to maintain.

It is another object of the present invention to provide a supercharger which provides sufficient boost without resort to extreme operating speeds and accordingly avoids the costly complications associated with high speed operation.

It is yet another object of the present invention to provide a relatively compact and lightweight supercharger which is inexpensive to manufacture and maintain.

Another object of the present invention is to provide a belt-driven supercharger having a design which provides supercharging compression at relatively low operating speeds.

It is still another object of the present invention to provide a supercharger which can be quite readily disassembled and reassembled for purposes of low cost maintenance and repair.

Still another object of the present invention is to provide a supercharger which can be constructed from mass producible parts to thereby reduce the cost of its manufacture.

It is still another object of the present invention to provide a belt-driven supercharger which provides supercharging compression without resort to a larger number of compressor stages.

Yet another object of the present invention is to provide a rotary supercharger for a gas operated engine, which supercharger is easily manufactured and maintained, yet capable of providing ample recompression of the recirculating drive fluid.

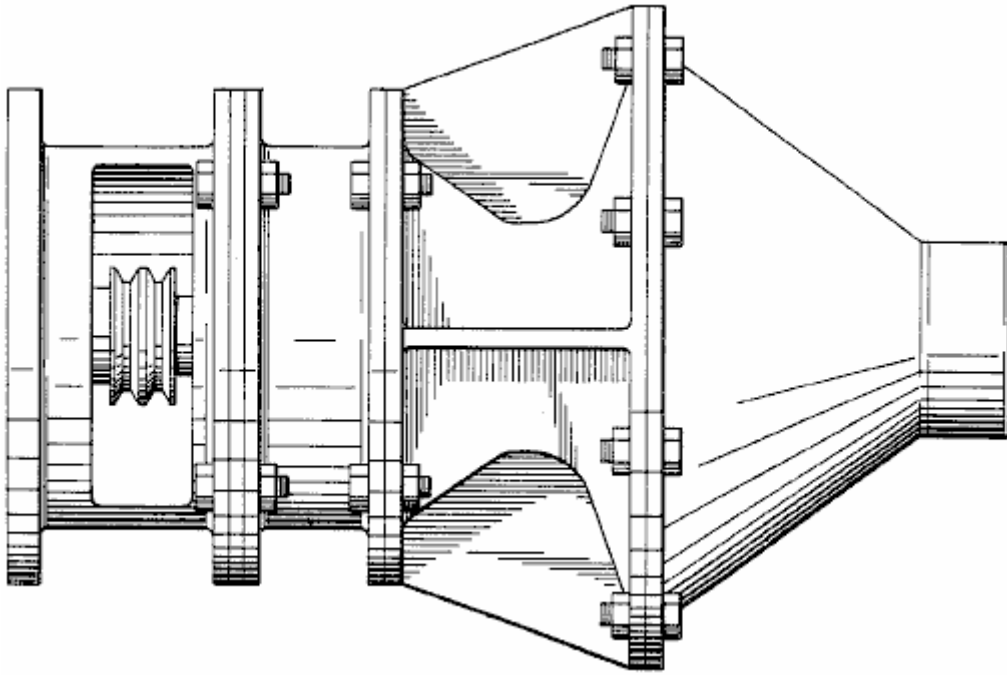

Summary of the Invention:

These and other objects are achieved by the present invention which provides a supercharger comprising a housing having an inlet and an outlet, a shrouded axial compressor and a radial compressor rotatably mounted within the housing, a highly convergent shallow, frustoconical transition duct for favourably directing the discharge of the axial compressor to the inlet of the radial compressor.

In accordance with a further aspect of the invention, the above-described supercharger further comprises an exhaust cone at a location downstream of the radial compressor and a flow deflector for directing the discharge of the radial compressor to the exhaust cone.

In the preferred embodiment, the housing itself comprises four sections: a cylindrical front housing section which defines an axially directed inlet; a second, cylindrical ducting section enclosing the axial compressor; a rear housing section defining the transition duct as well as the inlet and casing for the radial compressor; and the exhaust cone section which defines at its terminus the outlet of the housing. For driving the compressor shaft, a double-tracked pulley wheel is secured to the forward end of the common shaft, which pulley wheel is adapted to receive one or more drive belts from the crank-shaft wheel of the engine. A lateral opening in the front housing section accommodates the connection with the drive belts.

With the disclosed arrangement, compression can be achieved for supercharging purposes without resort to a large number of compressor stages or high operating speeds. Additionally, the design of the disclosed supercharger avoids the need for guide vanes between the axial compressor and the radial compressor. The exhaust cone section also favourably avoids the build-up of back pressure against the radial compressor. The design is also very simple and therefore inexpensive to manufacture and maintain.

Other objects, advantages and novel features of the present invention will become apparent from the following detailed description of the invention when considered in conjunction with the accompanying drawing.

Brief description of the Drawings:

A preferred embodiment of the present invention is described in greater detail with reference to the accompanying drawing wherein like elements bear like reference numerals, and where:

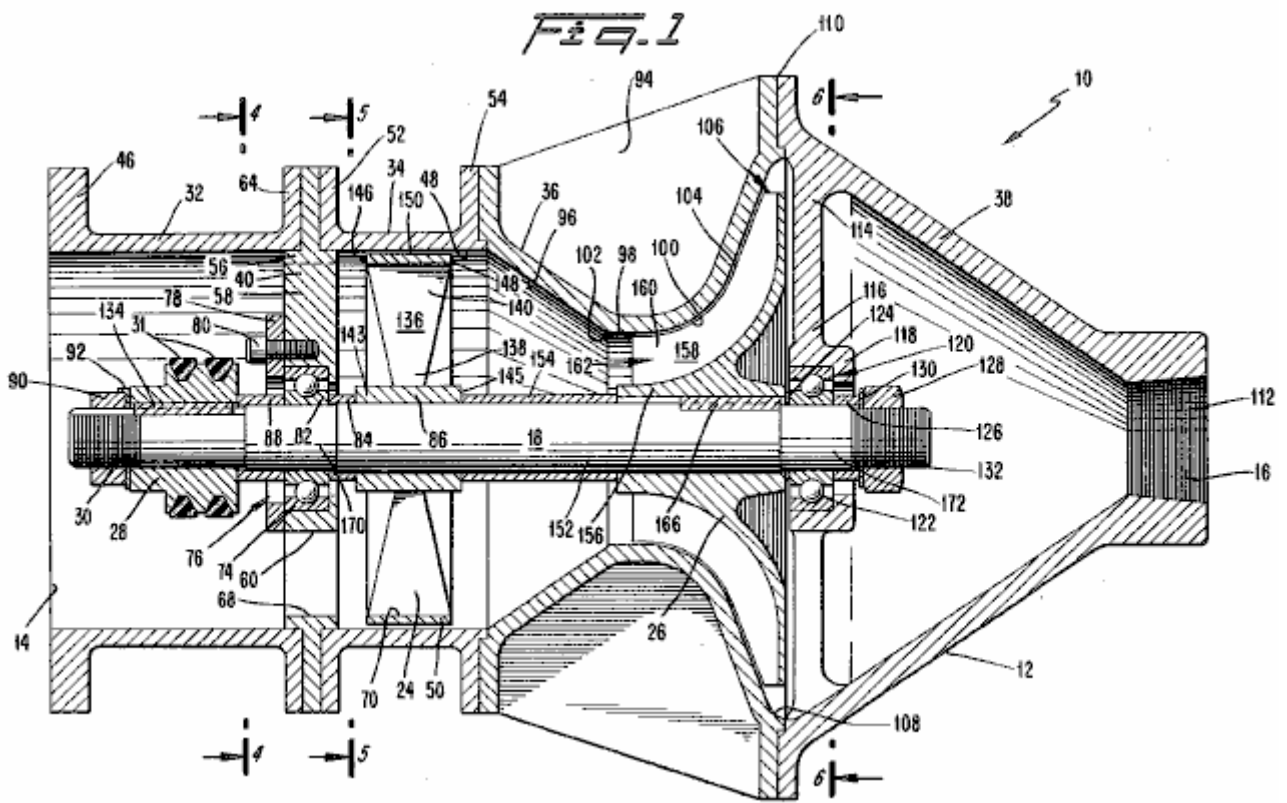

Fig.1 is a cross-sectional side view of a supercharger constructed in accordance with the preferred embodiment of the present invention;

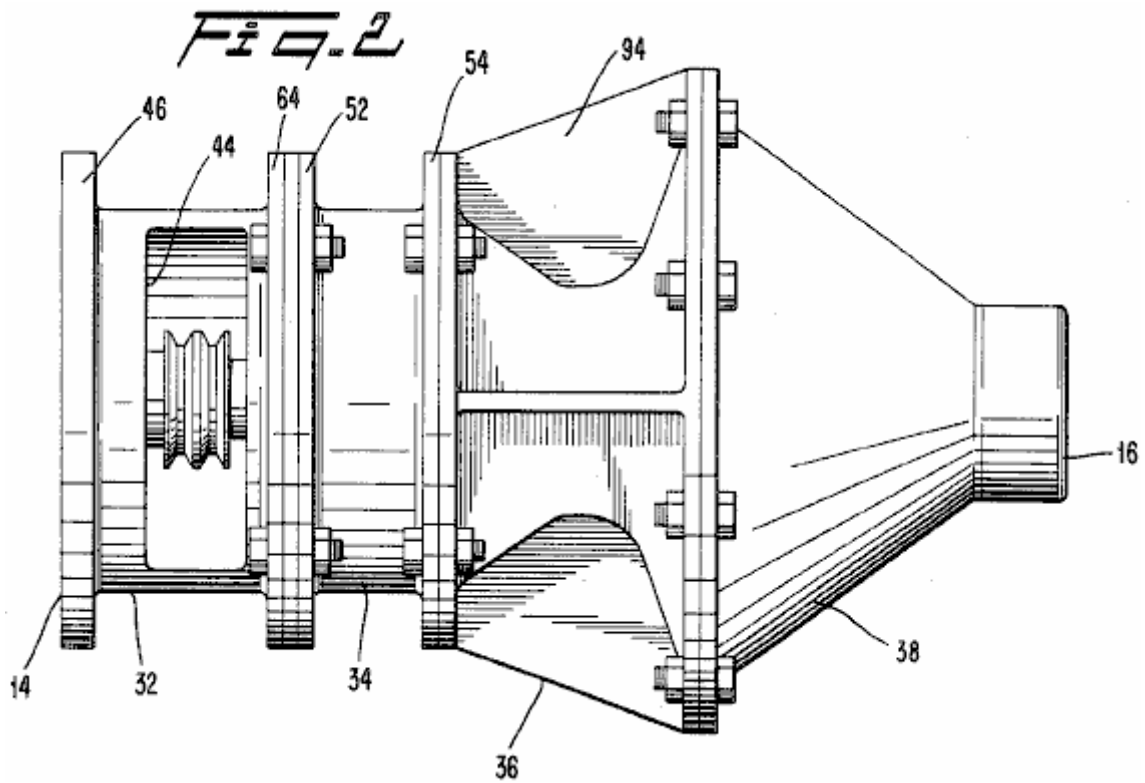

Fig.2 is a side view of the supercharger of Fig.1;

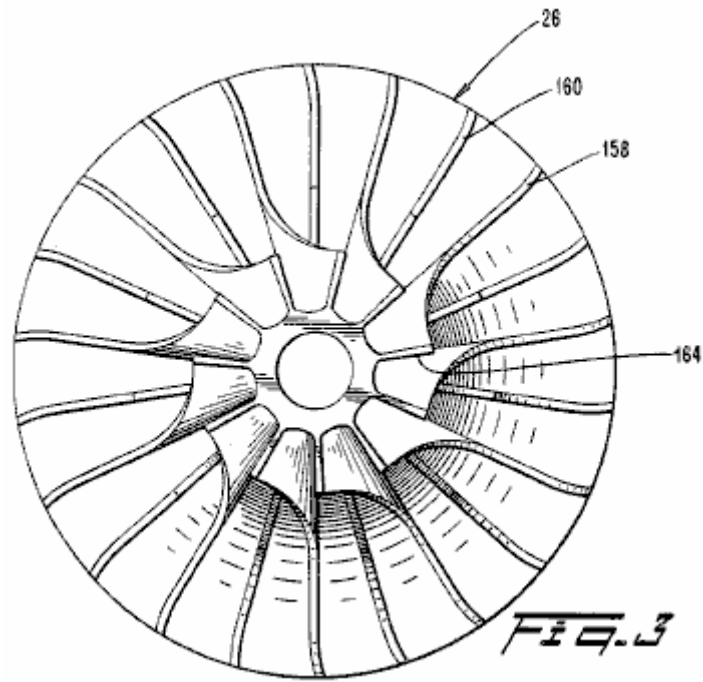

Fig.3 is a frontal view of the impeller of the supercharger of Fig.1;

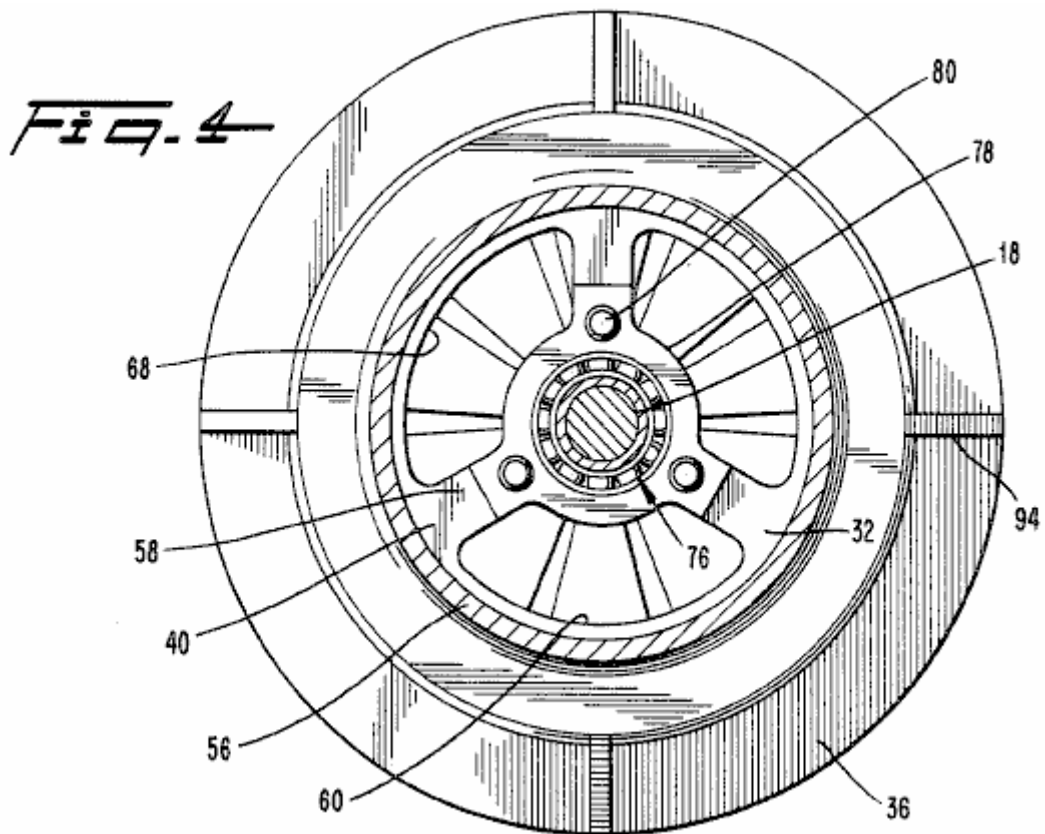

Fig.4 is a cross-sectional view taken along line 4--4 of Fig.1;

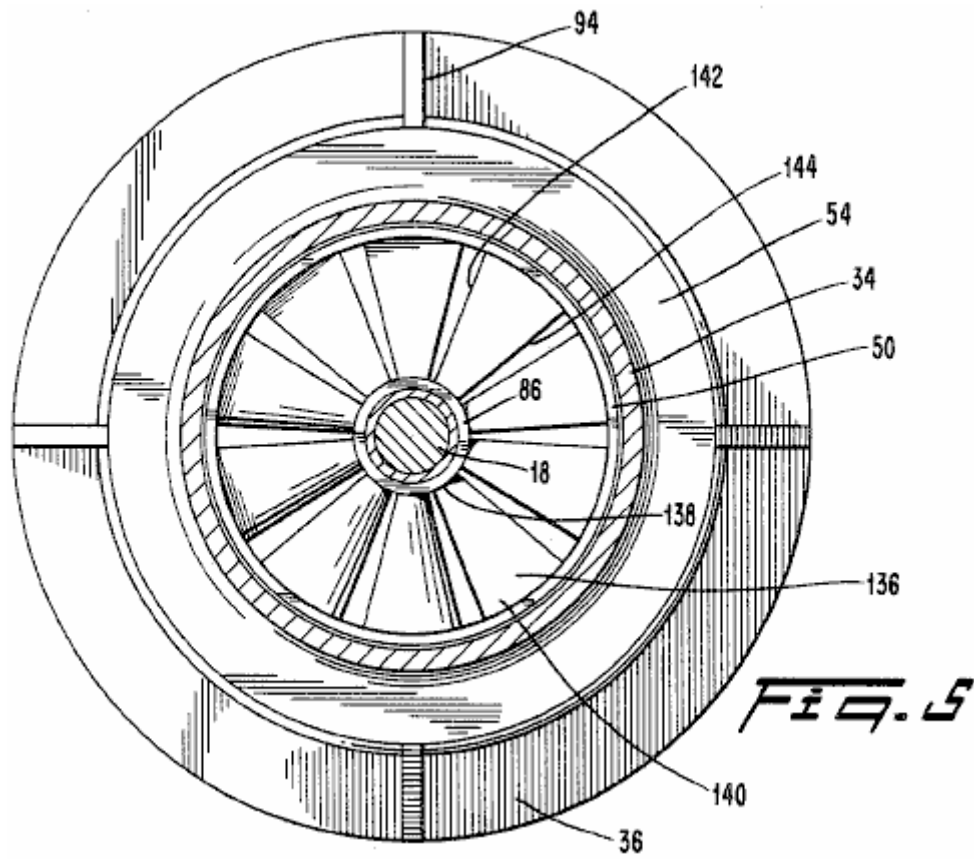

Fig.5 is a cross-sectional view taken along line 5--5 in Fig.1;

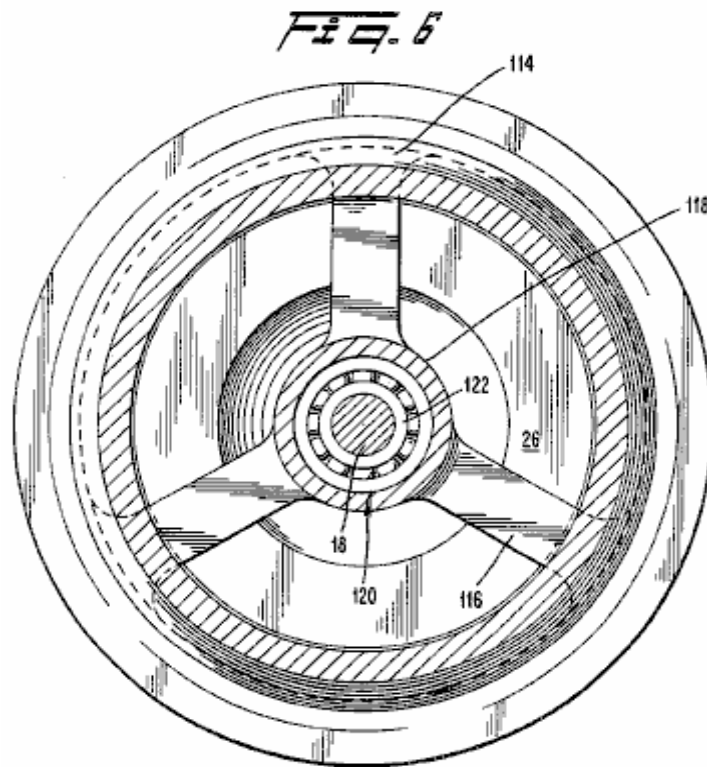

Fig.6 is a cross-sectional view taken along line 6--6 in Fig.1;

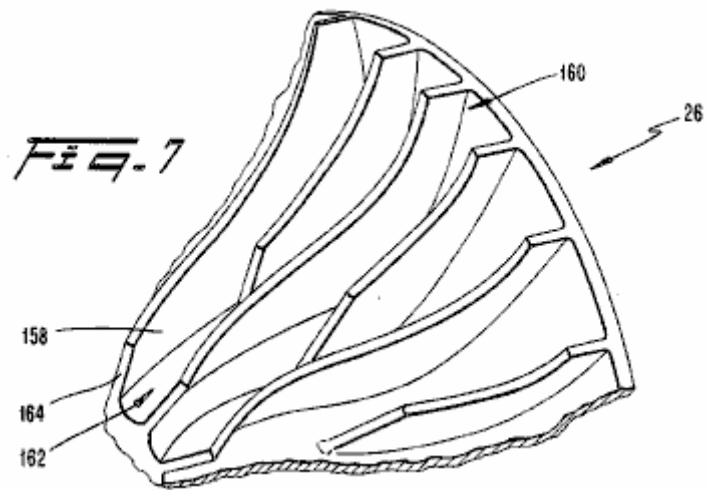

Fig.7 is a perspective view of a segment of the impeller of the supercharger of Fig.1; and

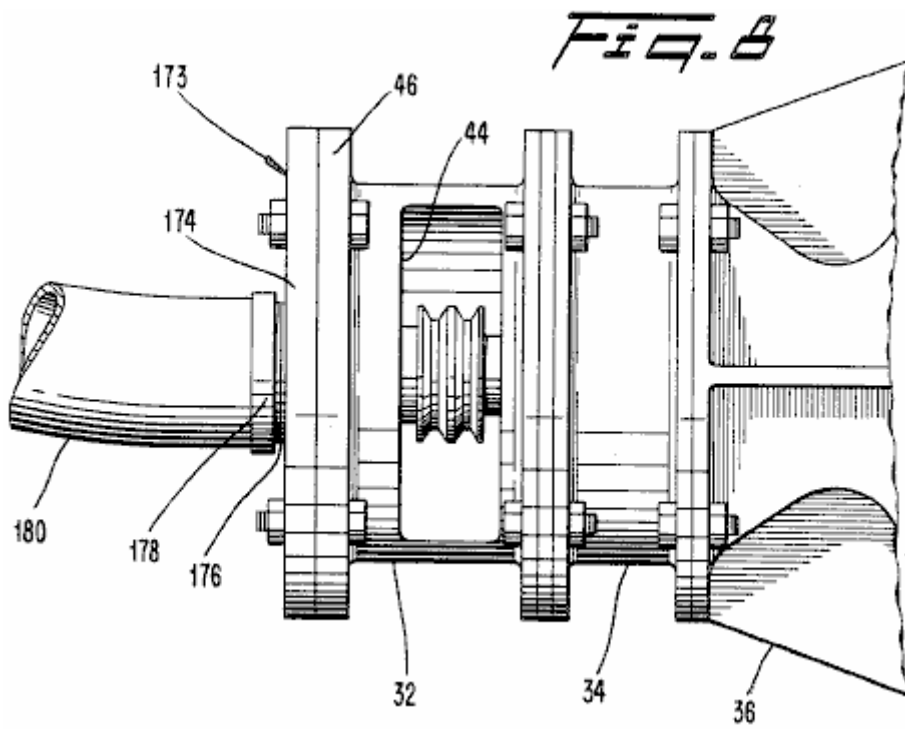
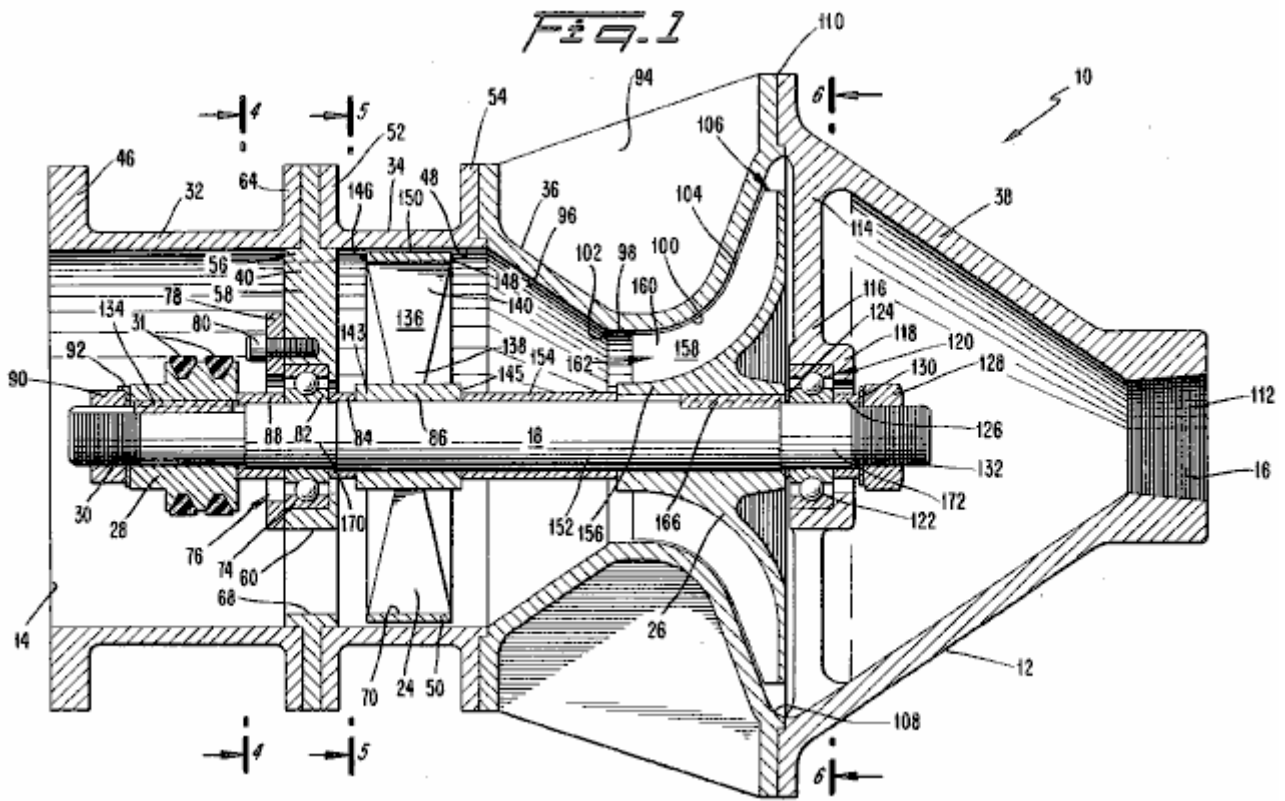

Fig.8 is a partial side view of the supercharger of Fig.1 with an adaptor .

Detailed Description of the Preferred Embodiment:



Referring to **Fig.1** and **Fig.2**, a supercharger **10** is provided for supplying supercharged air to a car engine or the like, so that the engine receives a greater weight per unit volume of air or a fuel/air mixture than would be otherwise supplied. In accordance with a preferred embodiment of the present invention, the supercharger **10** comprises a housing **12** having an axially directed inlet **14** for receiving ambient air and an axially directed outlet **16** for delivering supercharged air to the intake of the car engine. Rotatably mounted within the housing **12** is a shaft **18** on which are secured an axial compressor **24** and a radial compressor **26**, which is positioned downstream of the axial compressor. A pulley wheel **28** is secured to a forward end **30** of the shaft for receiving drive belts **31**, which drive belts connect the shaft **18** to a pulley wheel on the crankshaft of the engine (not shown). The drive belts **31** deliver torque to the shaft **18** as required for driving the compressors **24** and **26** of the supercharger **10**.

Housing **12** is constructed from four sections which are preferably bolted together at flanged connections in an end-to-end relationship. These sections include a front housing section **32**, an axial compressor duct section **34**, a rear housing section **36** and an exhaust cone section **38**. The shaft **18** extends along the longitudinal axis of the housing **12**.

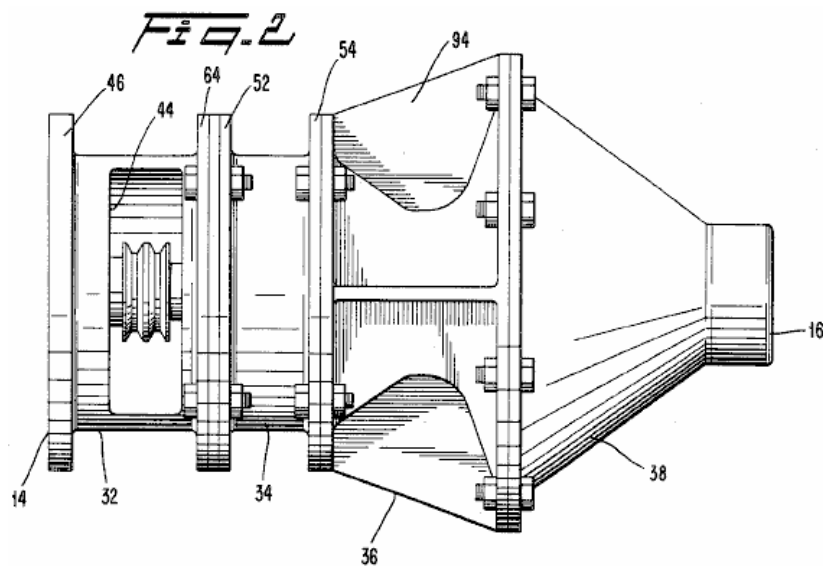

The front housing section **32** is a hollow cylinder which extends forward of a front bearing support **40**. The front housing section **32** encloses the forward end **30** of the shaft **18** and the associated pulley wheel **28**. At its forward end, the front housing section **32** defines the inlet **14** for receiving air from an external source (not shown).

Referring particularly to **Fig.2**, the front housing section **32** includes a lateral opening **44** on one side in order to accommodate the connection of the drive belts **31** to the pulley wheel **28**. The front housing section **32** also includes a forward flange **46** for accommodating the connection of air filters, carburetors, air scoops or the like upstream of the supercharger **10** according to the particular engine layout.

It is to be understood that in the usual engine layout, the supercharger **10** receives air or a fuel/air mixture from an external source through its inlet **14**, compresses the air or fuel/air mixture and then delivers it to the intake of the engine.

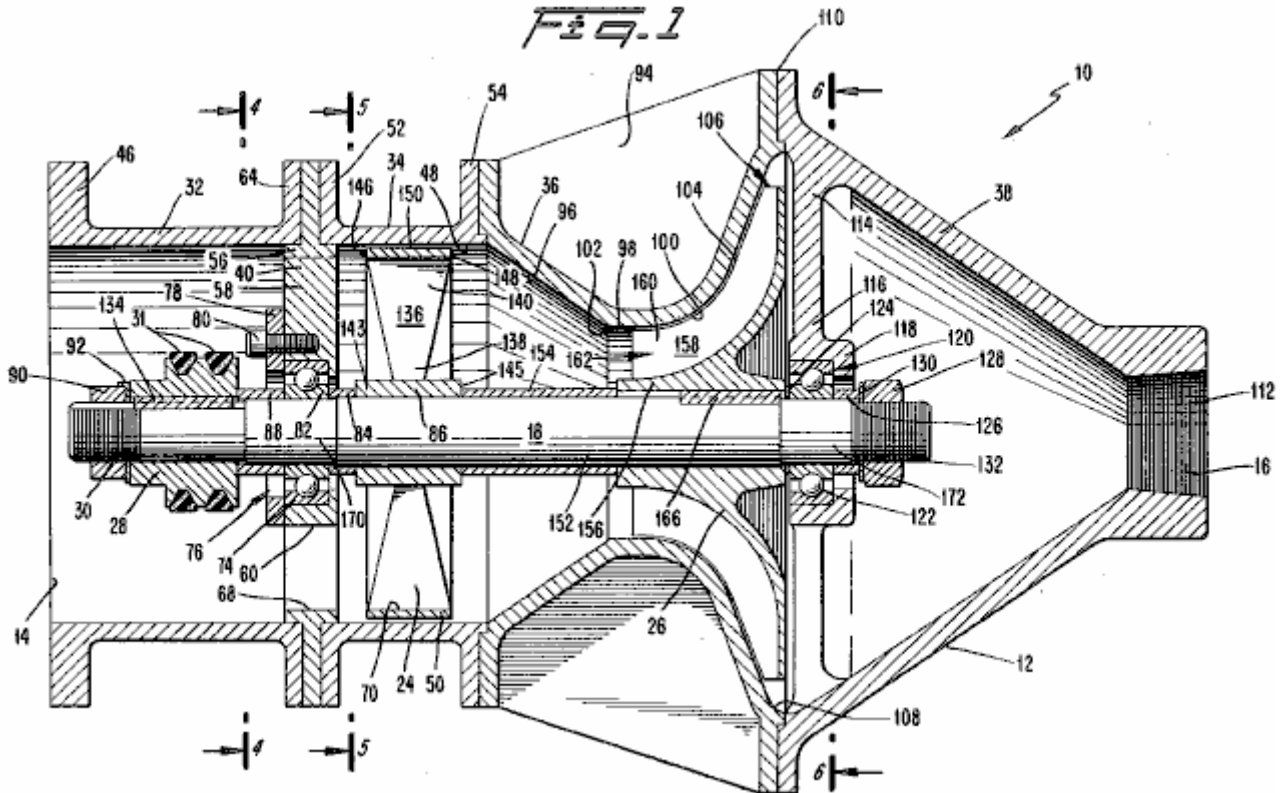

Referring again to **Fig.1**, the pulley wheel **28** is interference-fitted upon the forward end **30** of shaft **18** and a key **134** is used to lock the pulley wheel **28** in place. The pulley wheel **28** is preferably a double-track design which is suitable for the attachment of twin drive belts, although a single-belt type pulley wheel would be adequate. The pulley wheel **28** is preferably sized so that the ratio of its diameter with respect to the diameter of the drive wheel of the engine's crankshaft provides an effective gearing ratio in the range of approximately two and one-half to four and one-half. Thus at idle, when the car engine is running at approximately 700 rpm, the supercharger **10** is running at approximately 2,400 rpm, and at cruise, when the engine is running around 2,500 rpm, the supercharger **10** is preferably turning over in the range of 6,000 to 8,000 rpm. It is to be noted that although the diameter of the pulley wheel **28** may be substantially reduced in order to achieve a desired gearing ratio, the double-track wheel **28** presents a sufficient sum total of surface area to avoid slippage of the belts **31**.

The next adjacent section of housing **12** is the axial compressor duct **34** which is a short cylinder coaxially disposed about the axial compressor **24**. Preferably, the axial compressor duct **34** is constructed from cast aluminium, with the interior surfaces **48** machined to assure uniform clearance between the duct **34** and shroud **50** of the axial compressor **24**. As with other sections of the housing **12**, the axial compressor duct **34** is provided with flanges **52** and **54** for effecting connection to the adjacent housing sections. The axial compressor duct **34** guides air delivered from the front housing section **32** towards the axial compressor **24**.

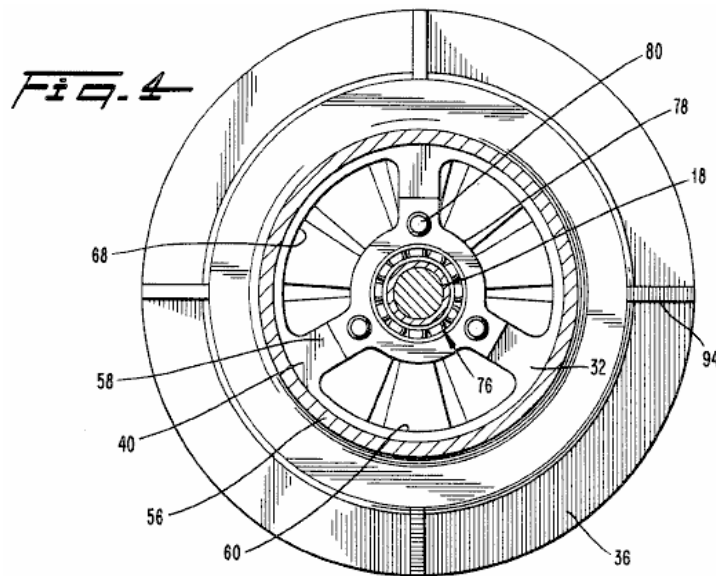

Referring now to **Fig.1** and **Fig.4**, a front bearing support **40** is placed between the front housing section **32** and the axial compressor duct **34**. The front bearing support **40** includes an outer annulus **56** and three radial arms **58**. Between these arms are defined passages **60** for allowing air to pass through the bearing support **40**. The outer annulus **54** is secured by bolts connecting a rear flange **64** of the front housing section **32** and the flange **52** of the axial compressor duct **34**. By this arrangement, the front bearing support **40** is rigidly secured to the housing **12** so that loads and shocks to the shaft **18** can be transferred through the front bearing support **40** to the housing **12**.

In the preferred embodiment, the outer annulus **56** of the bearing support **40** extends into the region of the inlet **14** of the front housing section **32** in such a way that its inner rim **68** coincides with the inner rim **70** of the shroud **50** of the axial compressor **24**. In this way, the outer annulus **56** contributes to the guiding of the flow of air toward the axial compressor **24**.

An outer raceway **74** of the front roller bearing assembly **76** is secured between the front bearing support **40** and a bearing retainer plate **78**, which is secured by the removable bolts **80**. In this preferred embodiment, the front bearing assembly **76** is of the sealed, high speed type. A suitable commercially available bearing assembly is marketed under the reference: model Fafnir 405KDD. Preferably, a lower raceway **82** of the front bearing assembly **76** is secured to the shaft **18** with an interference fit. A spacer **84** is provided on one side of the lower raceway **82**, which spacer **84** also abuts a hub **86** of the axial compressor **24** in order to position the axial compressor **24** at a predetermined distance downstream of the bearing support **40**. Similarly, a spacer **88** is provided on the other side of the lower raceway **84**, and it abuts the pulley wheel **28** so as to space apart the pulley wheel **28** from the front bearing support **40** to ensure that there is sufficient clearance between them.

It should be appreciated that the bearing retainer plate **78** allows ready access to the front bearing assembly **76** for purposes of maintenance or repair. To service the front bearing assembly **76**, a nut **90** and lock-washer **92** on the forward end **30** of the shaft **18** are loosened and removed together with the pulley wheel **28** and the spacer **88**. Then bolts **42** and the bearing retainer plate **76** are removed, leaving the whole bearing assembly **76** exposed for servicing and/or removal.

The rear housing section **36** is connected by bolts to the downstream end of the axial compressor duct **34**. Preferably, the rear housing section **36** is constructed from a single section of cast aluminium and includes external longitudinal ribs **94** for enhancing the structural rigidity of the rear housing section **34**. The walls of the rear housing section **36** define three elements of the supercharger **10**: a highly conical transition duct **96** which favourably directs the output of the axial compressor to an inlet **98** of the radial compressor **26**; the inlet **98** of the radial compressor **26**, itself; and a casing **100** for the radial compressor **26**.

The transition duct **96** is a hollow, frustoconical portion having a half-apex angle (from the generatrix to the axis of symmetry) of approximately 35°. The angle is selected such that the inlet to the radial compressor **26** is as close as possible to the outlet of the axial compressor, without causing undue back-pressure. In the preferred embodiment, the transition duct **96** begins a short distance downstream of the axial compressor **24** and ends at the beginning of the inlet **98** of the radial compressor **26**. The highly conical shape of the

transition duct **96** is believed to roll-in the higher volume of air being discharged from the more radially outward portions of the axial compressor **24**. This rolling-in action is believed to promote a favourable flow regime at the inlet **98** of the radial compressor **26** so that there is no need for inlet guide vanes for the radial compressor **26**. It is also believed that the highly conical shape of the transition duct **96** affects upstream flow conditions at the axial compressor **24** in such a way that its performance is improved. It has also been found that there is no need for a stator (or exit guide vane) for the axial compressor **24**.

In essence, it is believed that the transition duct **96** performs the functions of the exit vanes of axial compressors and inlet guide vanes of radial compressors, but without the pressure losses commonly associated with them. Avoiding these pressure losses and the expected improvement in the performance of the axial compressor, allows the supercharger **10** to impart a higher overall pressure ratio than would otherwise be achieved without the transition duct **96**. As a result, adequate compression is achieved at moderate operating speeds without resort to a bank of several axial compressors. It should be understood however, that when connecting the supercharger **10** to a relatively slowly reciprocating diesel or a very large engine, it may be desirable to include two or more axial compressors in order to boost the supercharger's overall pressure ratio. In such cases, the present invention would then include the placement of a transition duct downstream of at least the last axial compressor.

At the inlet **98** of the radial compressor **26**, the walls of the rear housing **36** are cylindrical and coaxially positioned around shaft **18**. It should be noted that in the preferred embodiment, the surface transition **102** from the transition duct **96** to the inlet **98** is rounded-off.

The casing portion **100** of the rear housing section **36** closely follows the contour defined by blade edges **104** of the radial compressor **26** in a close, substantially sealing manner as is well known in the art of radial compressors. The casing portion **100** of the rear housing section **78** channels air between the rotating blades of the radial compressor **26** so that the blades can impart work to the passing air. The casing portion **100** also defines a discharge outlet **106** for the radial compressor **26**.

Just beyond the discharge outlet **106** of the radial compressor **26**, the interior surfaces of the rear housing section **36** begin to curve immediately inwardly to provide a transition into the next adjacent section of the housing **12**, the exhaust cone **38**. In this fashion, the interior surfaces at the rear-most portion of rear housing section **36** and those of the forward portion of the exhaust cone **92** define internally a flow deflector **108**. In the preferred embodiment, the flow deflector **108** is closely and concentrically positioned around outlet **106** of the radial compressor **26** so that the air being discharged from the radial compressor **26** does not have the opportunity to diffuse significantly prior to its arrival at the annular flow deflector **108**. The annular flow deflector **108** directs the output of the radial compressor **26** into the exhaust cone **38** by providing a smooth surface transition from the interior of rear housing section **36** to the interior of the exhaust cone **38**.

The exhaust cone **38** is a highly convergent, hollow, conical section placed immediately downstream of the radial compressor **26** for receiving the output of the radial compressor **26** from the annular flow deflector **108**. In the preferred embodiment, the exhaust cone **38** is a single section of cast aluminium which is joined to the downstream end of the rear housing section **36** at a flanged joint **110**. Preferably, the exhaust cone **92** converges according to a half-apex angle of approximately 35° and defines the exhaust port **16** at its terminus. A threaded section **112** at the exhaust port **16** allows the attachment of the appropriate external ducting (not shown) leading to the intake of the engine.

During operation of the supercharger **10**, the space enclosed by the exhaust cone **92** prevents the build up of an elevated back pressure which might otherwise arise and detract from the operation and efficiency of the radial compressor **26**. The enclosed space of the exhaust cone **92** is also of sufficient volume to absorb pulses and to average out unsteady flow conditions so to promote a smooth and continuous output from the supercharger **10**.

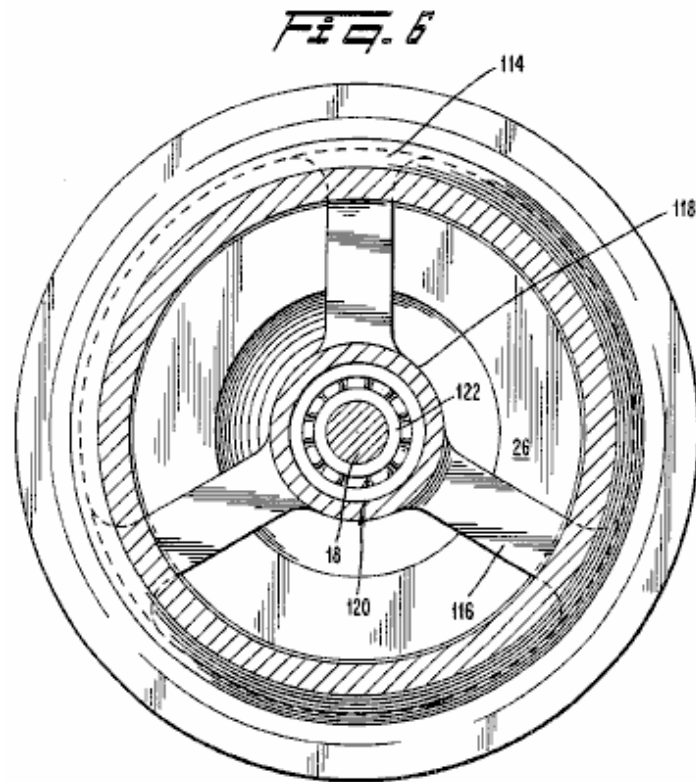

Referring now to **Fig.1** and **Fig.6**, the exhaust cone **38** includes a rear bearing support **114** which comprises members **116** which extend radially inwardly from the outer walls of the exhaust cone **38**. At a radial inward location close to the shaft **18**, the members **116** converge to form a cupped annulus which serves as a housing **118** for the rear bearing assembly **120**. The housing **118** is open towards the rear face of the radial compressor **24** to facilitate disassembly of the supercharger **10**. The rear bearing assembly **120** is the same type and size as the front bearing assembly **76**. The inner race **122** of the bearing assembly **120** is set in place on the shaft **18** by spacers **124** and **126** in conjunction with a nut **128** and washer **130** on the rearward end **132** of the shaft **18**. In this preferred embodiment, the members **116** are formed to be integral with the walls of the exhaust cone **38**.

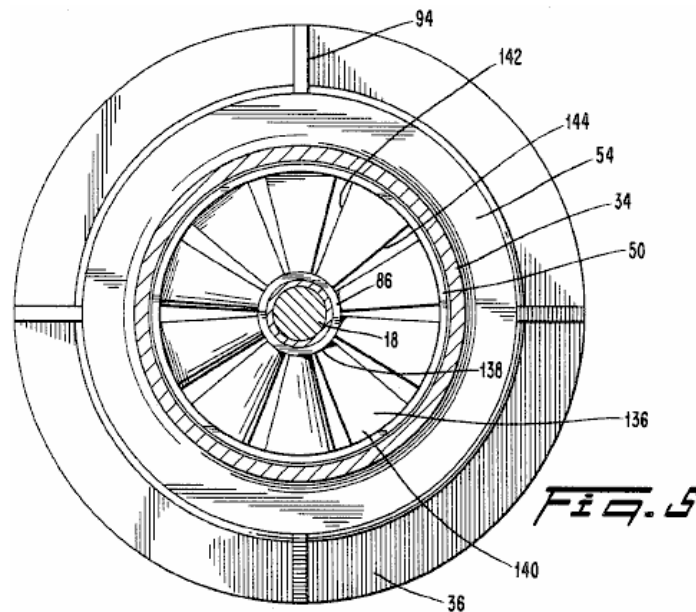

Referring to **Fig.1** and **Fig.5**, upon rotation, the axial compressor **24** draws air through the inlet **14** and imparts an initial amount compression to the air as it forces the air into the transition duct **96** of the rear housing section **36**. In the preferred embodiment, the axial compressor **24** comprises a hub **86**, the shroud **50** and a series of ten (10) equally spaced, radial blades **136**. Ideally, each blade **136** increases in cord from a root **138** to a tip **140** and includes a trailing edge **142** and a leading edge **144**, where these edges are both

slightly curved. The blades gradually increase in pitch from approximately 12° at the root 138 to approximately 36° at the tips 140. However, the particular values of pitch and other geometrical aspects of the blades 136 might be varied in accordance with different operating speeds or other parameters as would be apparent to one skilled in the pertinent art and familiar with this disclosure.

The axial compressor 24 is preferably constructed from a single, cast aluminium section with the faces 143 and 145 of the hub 86 being machined for purposes of achieving accurate, axial positioning of the axial compressor 24 on the shaft 18 relative to the housing 12. The faces 146 and 148 of the shroud 72 are also machined flat. Additionally, the outer periphery 150 of the shroud is machined to assure uniform clearance between the shroud and the adjacent interior surfaces 48 of the axial compressor duct 34. Preferably, the axial compressor 24 is secured to the shaft 18 by an interference-fit on to a stepped portion 152 of the shaft 18. The spacers 84 and 154 axially position the axial compressor 24 relative to the front bearing support 40 and the radial compressor 26, respectively.

Dynamic balance test machines of the conventional type may be used to test the balance of the axial compressor 24 prior to its installation. If an imbalance is detected, material can be removed at the outer periphery 150 of the shroud 50 so as to achieve proper balance.

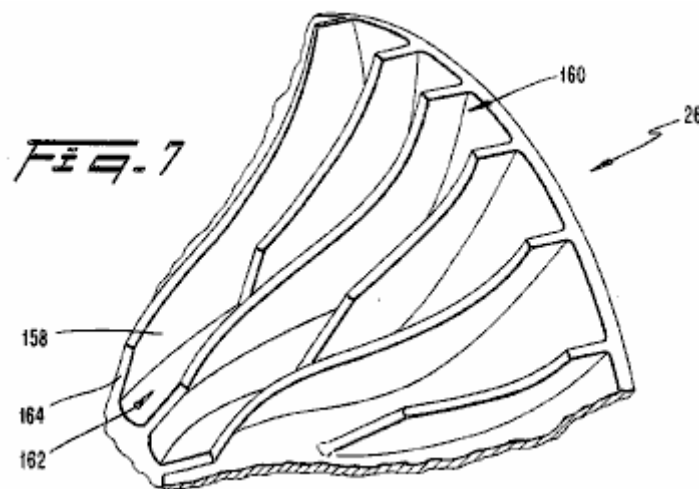

Referring now to Fig.1, Fig.3, and Fig.7, the radial compressor 26 is constructed from a single section of cast aluminium and includes a hub 156 and curved blades 158. Interposed between each pair of blades 158 are a second set of blades 160 which terminate short of the intake 162 of the radial compressor 26 so that the intake 162 is not crowded by both sets of blades. Accordingly, the radial compressor 26 features both a large total number of blades and an intake of relatively small diameter, and these features enhance the performance of the compressor 26. In the region of the intake 162, the blades 158 present leading edges 164 and undergo a twist into the direction of rotation so as to prevent a favourable angle of attack at the intake 162.

Preferably, the radial compressor 26 is positioned upon the stepped section 128 of the shaft 18 with an interference-fit and locked against rotational slippage by a key 166. The spacer 124 assures clearance between the rear face of the radial compressor 26 and the rear bearing assembly 120.

The shaft 18 is constructed from a hardened steel and is threaded at both ends 30 and 132 to receive nuts 90 and 128, respectively. In addition to the central stepped portion 152, which receives the compressors 24 and 26, the shaft 18 also features stepped portions 170 and 172 for receiving the front and rear bearing assemblies 76 and 120, respectively. The stepped arrangement of the shaft 18 facilitates assembly and disassembly in that the stepped portion 152 of the greatest diameter is centrally located on the shaft 18 and all the stepped portions are greater than the diameter of the threading at ends 30 and 132.

Please note that the bearing supports 40 and 114 are in a fixed position relative to the housing 12 and that the compressors 24 and 26 are held in position between the bearing supports 22 and 40 by spacers 84, 124 and 154, which have predetermined lengths. Consequently, the placement of the compressors 24 and 26 relative to the longitudinal axis of the housing 12 is fixed by the spacers and not by the axial location of the shaft 18 relative to the housing 12. Please also note that the stepped portions 152, 170 and 172 of the shaft 18 are each provided with extra lengths so that the respective components (the bearing assemblies and compressors) can each be situated over a relatively wide range of locations in the respective stepped

portions. Thus, the shaft **18** need not be positioned accurately along the longitudinal axis of the housing **12** in order to achieve proper assembly of the supercharger **10**. For instance, if nuts **90** and **128** had been tightened differently than they appear in **Fig.1**, then shaft **18** might have been displaced slightly in the axial direction from where it is shown in **Fig.1**. However, the relative positioning of the various components on the shaft **18**, i.e., the pulley wheel **28**, the compressors **24** and **26** and the bearing assemblies **76** and **120**, would have remained the same relative to themselves and the housing **12**. This feature eases the process of manufacture and accordingly, reduces costs. It also reduces the amount of labour required for reassembly after repair.

In operation, the supercharger **10** is suitably connected at its outlet **16** to an intake of a car engine, with the drive belts **31** from the crankshaft of the engine being attached to the pulley wheel **28** of the supercharger **10**. Then, as the engine is operated, torque is transferred by the drive belts **31** to the pulley wheel **28** for driving the compressors **24** and **26**. Upon rotation, the axial compressor **24** draws air through the inlet **14**, imparts an initial amount of compression to the air and discharges it into the transition duct **96** with a swirl. By reason of its design, the axial compressor **24** is believed to move a greater volume of air in the region of its blade tips **140** than at its more radially inward locations. Accordingly, there is a greater mass of air situated at the outer annular region behind the axial compressor **24** than at the inner annular region. As the discharge from the axial compressor **24** is caused to leave the axial compressor duct **34**, the highly convergent, transition duct **96** is believed to cause the outer annulus of air which is discharged from the axial compressor **24** to roll-in. This action is believed to have two favourable results. First, the roll-in action causes a flow regime to be established at the inlet **98** of the radial compressor **26** such that the need for a guide vane is wholly avoided. Secondly, and of equal importance, the rolling-in action, in conjunction with the large volume of space enclosed by the transition duct **96**, is believed to affect the performance of the axial compressor **24** favourably, so that a higher pressure ratio is obtained from it.

Since the overall pressure ratio of the supercharger **10** is the product of the pressure ratios of the two compressors, it can be seen that the increase in performance of the axial compressor **24** results in a corresponding improvement in overall performance of the supercharger. It should also be noted that the deletion of inlet guide vanes for the radial compressor **26** and of exit vanes for the axial compressor **24** greatly simplifies the design of the rear housing section **36** and therefore provides savings in costs of manufacture. It also avoids the pressure losses associated with such guide vanes, which are often quite significant.

Upon leaving the transition duct **96**, the pre-swirled flow of air enters the inlet **98** of the radial compressor **26** and then into the compressor **26** itself. In passing through the radial compressor **26**, the air is turned and whirled such that the airflow is centrifugally discharged with a substantial radial velocity component, whereupon the resultant flow is abruptly turned by the annular flow deflector **108** and caused to enter the exhaust cone **38**. As previously explained, the large volume of space enclosed by the exhaust cone **38** induces flow conditions behind the radial compressor **26** such that elevated back pressures are avoided, pressures which might otherwise impair the performance of the radial compressor **26**. Pulses in the output of the radial compressor **26** are also moderated. The air is then delivered in a compressed state to the exhaust port **16** of the exhaust cone **38**. The supercharged air then flows down the appropriate intake system of the engine until it reaches the cylinder or cylinders of the engine.

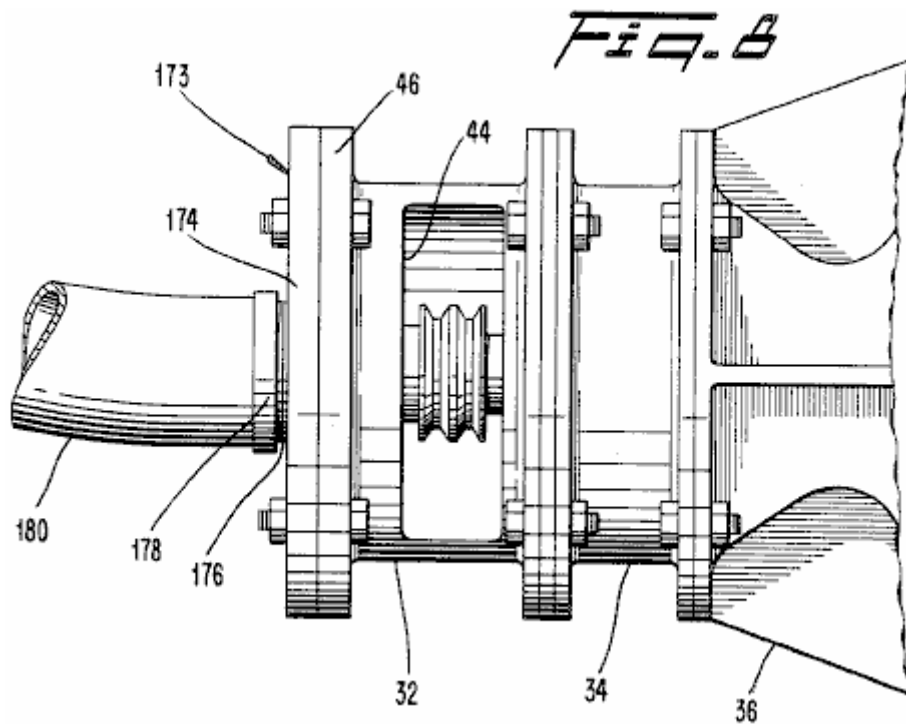

With respect to the application of the supercharger **10** to air-tank powered engines, such as disclosed in U.S. Pat. No. 4,292,804, the supercharger **10** functions in the same manner as described above, but is connected to the engine differently. In the air tank powered engine, at least one of the exhaust manifolds of the engines delivers partially expanded air to a line connected to the inlet **14** of the supercharger **10**. Referring to **Fig.8**, in most of such applications, this line will be of a smaller diameter than the housing **12** at the inlet **14** of the supercharger, such that an adaptor **173** is needed. The adaptor **173** comprises an annular plate **174** having a threaded aperture **176** sized to receive a mating, threaded end **178** of the line **180**. The plate **174** is secured to the flange **36** of the front housing section **32** by a plurality of bolts. Because the air coming from the line **180** is usually less than the full capacity of the supercharger, additional air is introduced through the lateral opening **44** along the side of the front housing section **32**. In this application, the opening **44** thus serves as an air intake port as well as a means for accommodating the drive belts **31** and must therefore be sized upon the additional criteria that it not be so large as to upset the flow of the incoming air in the line **180**. Upon the passage of the air through the supercharger, the air is directed through the exhaust port **16** and into a suitable line connected to it, which line may lead directly to the engine or to the storage tanks of the engine. If directed to the tanks, this recompressed air is used to supplement the required recharging of the storage tanks.

It is to be appreciated that savings in the cost of manufacturing the supercharger **10** are achieved by reason that the housing **12**, the bearing supports **40** and **114**, the axial compressor **24** and the radial compressor **26** are all constructed from cast aluminium parts and require only a minimum amount of machining. Moreover, the roller bearing assemblies **76** and **120** are commercially available components, and the supercharger **10** is easily assembled. These aspects further reduce the cost of manufacture and render the disclosed supercharger inexpensive to maintain and overhaul. More importantly, the supercharger **10**, despite its simple design, provides supercharging at relatively low operating speeds. With its lower operating speeds, the service life of the supercharger **10** is extended and the risk of it suffering mechanical failure is reduced. The need for special bearing designs and lubrication is also avoided. Accordingly, the supercharger **10** is highly suitable for mass production and for use in cars, trucks, helicopters or the like.

The Vortex Tube.

The web site <http://www.airtxinternational.com/stainless-steel-vortex-tubes.html> show "vortex tubes" which are completely passive devices with no moving parts:

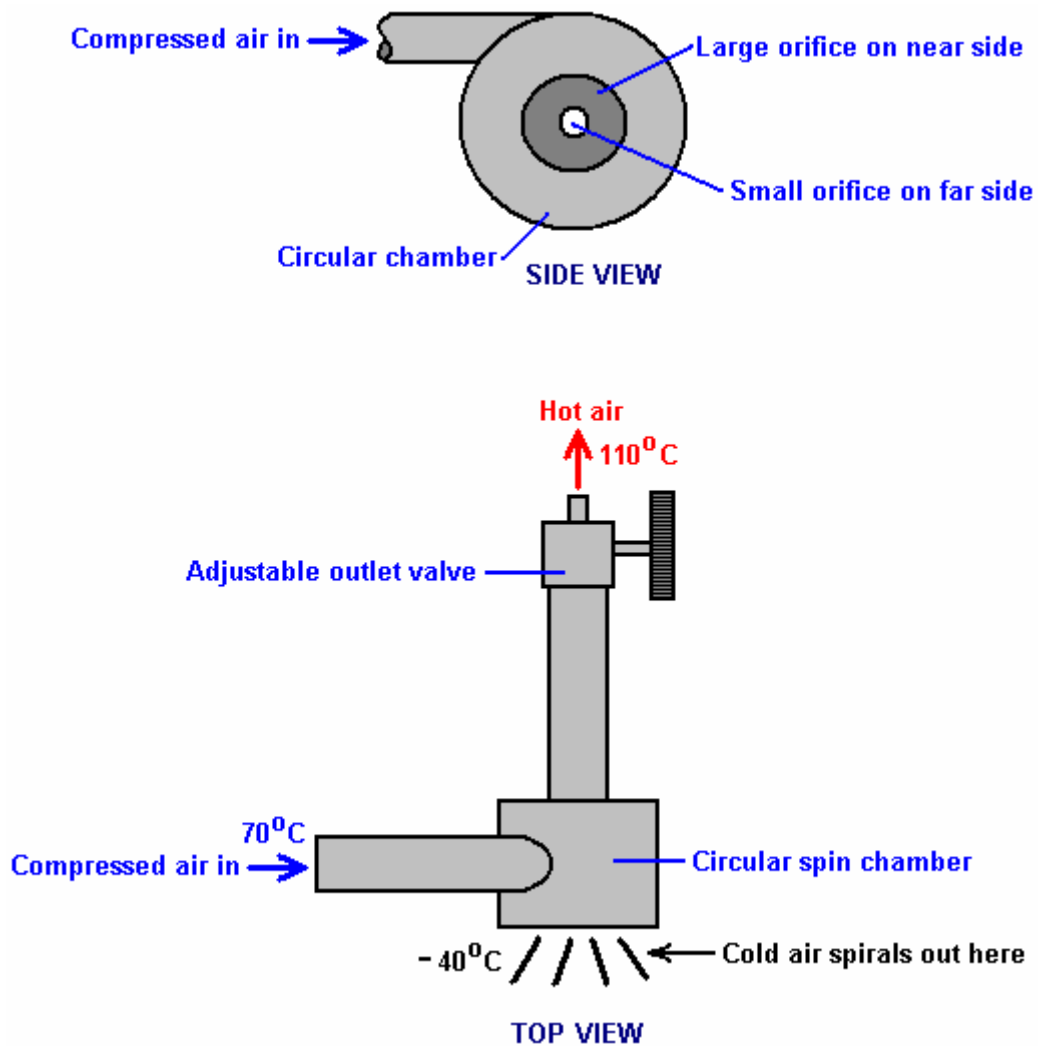

This device does things which you would not expect. Compressed air at a temperature of, say, seventy degrees Centigrade is fed into the circular chamber where the shape of the chamber causes it to spiral rapidly as it exits the tube:

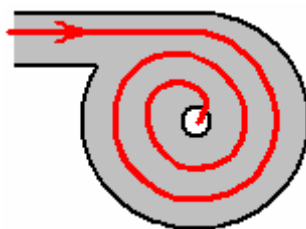

There is an energy gain in a vortex, as can be seen in a hurricane or tornado, but the really interesting thing here is the dramatic change in temperature caused by the change in pressure as the air expands. The ratio of heat gain to heat loss is controlled by the ratio of the sizes of the openings, which is why there is an adjustable nozzle on the small opening.

The air exiting through the large opening is much higher volume than the air exiting through the small opening and it expands very rapidly, producing a massive drop in temperature. The density of this cold air is now much higher than the air entering the vortex chamber. So there has been both a drop in temperature and an increase in density. These features of the expansion are made use of in the Leroy Rogers engine design, where some of the expanded air exhaust of the engine is compressed and passed back to the main air storage tank. While the compressor does raise the air temperature as it pumps the air back into the tank, it does not reach its original temperature instantly.

This results in the air temperature inside the tank dropping as the engine operates. But, the lowered tank temperature causes an inflow of heat from its immediate environment, raising the overall tank temperature again. This warming of the chilled air causes the tank pressure to increase further, giving an energy gain, courtesy of the local environment. It is important to understand that it takes less energy to compress air than the kinetic energy which can be generated by letting that compressed air expand again. This is a practical situation, courtesy of the local environment and is not a breach of the law of Conservation of Energy. It is also a feature which has not yet been exploited to any great degree and which is just waiting to be used by any adventurous inventor or experimenter.

Eber Van Valkenburg’s Engine.

Eber presents a custom engine based on these principles. His engine uses both compressed air and compressed oil to manipulate pressures within the system and provide an engine which is self-powered. In the Appendix is a slightly re-worded copy of the Eber Van Valkenburg patent, which remarks that “stored energy in a compressed elastic fluid is utilised in a controlled manner to pressurise an inelastic fluid and to maintain such pressurisation. The pressurised inelastic fluid is throttled to the impeller of a prime mover. Only a portion of the output energy from the prime mover is utilised to circulate the inelastic fluid so as to maintain a nearly constant volumetric balance in the system”.

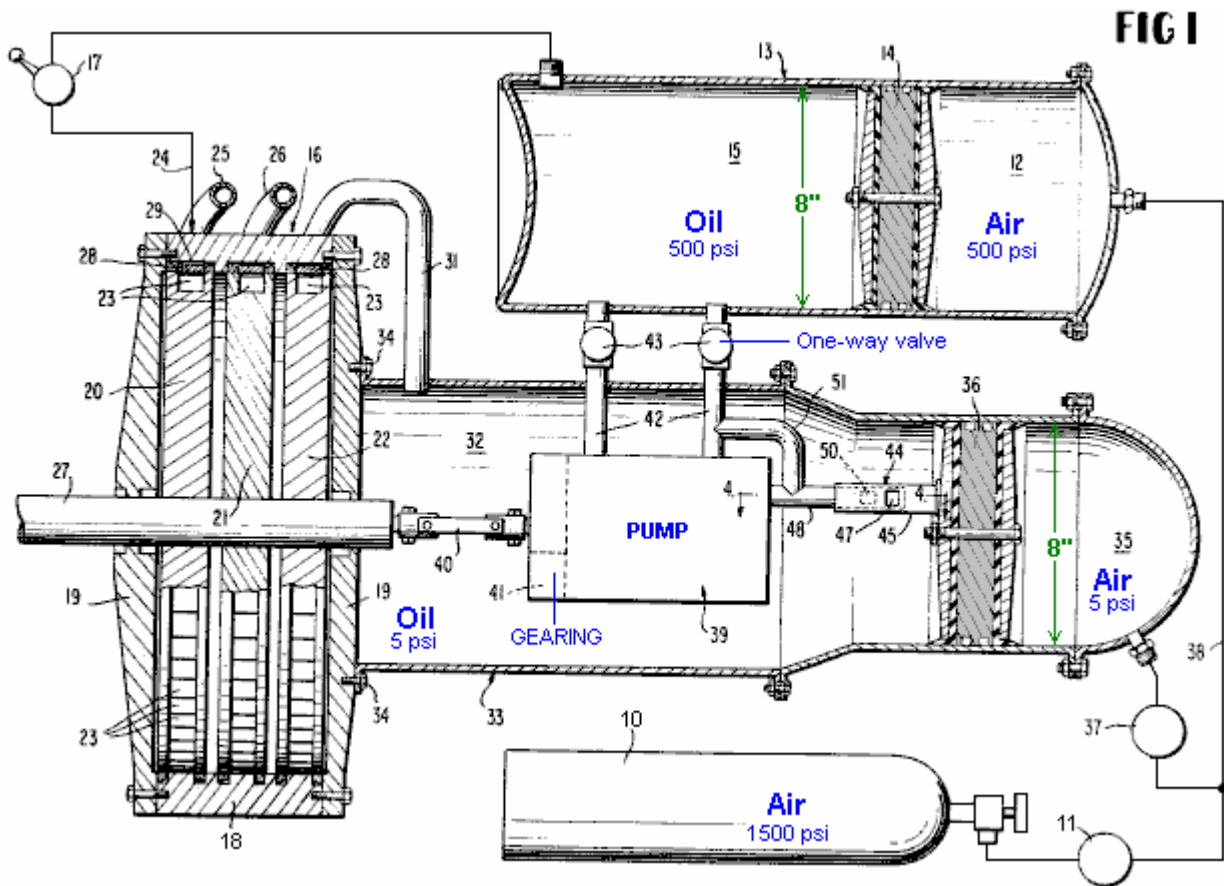

Richard Clem’s Motor.

The Clem Engine is based on an entirely different principle, and one which is not spoken about very often. Hurricanes or “twisters” as they are sometimes called, are large rotating air masses of incredible power which develop in hot areas which are more than eight degrees North or South of the equator. The distance from the equator is essential as the rotation of the Earth is needed to give them their initial spin. They usually develop over water which is at a temperature of twenty-eight degrees Centigrade or higher as that allows the air to absorb enough heat energy to get started. That is why there is a distinct “hurricane season”

in these areas, since at certain times of the year the ocean temperature is just not high enough to trigger a hurricane.

What is not generally realised is that a hurricane develops excess energy due to its swirling circular movement. The generation of this extra power was observed and documented by Viktor Schauberger of Austria, who also used his observations to great effect. I think that what Schauberger says makes some people uncomfortable as they seem to think that anything “unorthodox” has to be weird and too peculiar to be mentioned. This is rather strange as all that is involved here is a simple observation of how our environment actually works. A hurricane is wider at the top than at the bottom and this concentrates power at the base of the swirling mass of air. This tapered rotation is called a “vortex” which is just a simple name to describe the shape, but any mention of “vortex power” (the power at the base of this rotation) seems to make many people uncomfortable which is most peculiar.

Leaving that aside, the question is “can we use this energy gain from the environment for our own purposes?”. The answer may well be “Yes”. Perhaps this principle is utilised by Richard Clem. In 1992, Richard Clem of Texas, demonstrated a self-powered engine of an unusual type. This engine, which he had been developing for twenty years or more, weighs about 200 pounds (90 kilos) and generated a measured 350 horsepower continuously over the full period of a nine-day self-powered test. Although this engine which runs from 1,800 to 2,300 rpm is especially suited to powering an electrical generator, Richard did install one in a car, and estimated that it would run for 150,000 miles without any need for attention and without any kind of fuel. Richard said that his prototype car had reached a speed of 105 mph. Just after receiving funding to produce his engine, Richard died suddenly and unexpectedly at about 48 years of age, the death certificate having “heart attack” written on it as the cause of death. Remarkably convenient timing for the oil companies who would have lost major amounts of money through reduced fuel sales if Richard’s motor had gone into production.

The motor is unusual in that it is a rotary turbine style design which runs at a temperature of 300°F (140°C) and because of that high temperature, uses cooking oil as its operational fluid, rather than water as the oil has a much higher boiling point. To a quick glance, this looks like an impossible device as it appears to be a purely mechanical engine, which will definitely have an operating efficiency which is less than 100%.

In broad outline, the oil is pumped through a pipe and into the narrow end of the cone-shaped rotor. The engine is started by being rotated by an external starter motor until it reaches the speed at which it generates enough power to be sustain its own operation. The rapid spinning of the cone, causes the oil to run along spiral grooves cut in the inner face of the cone and exit through angled nozzles placed at the large end of the cone:

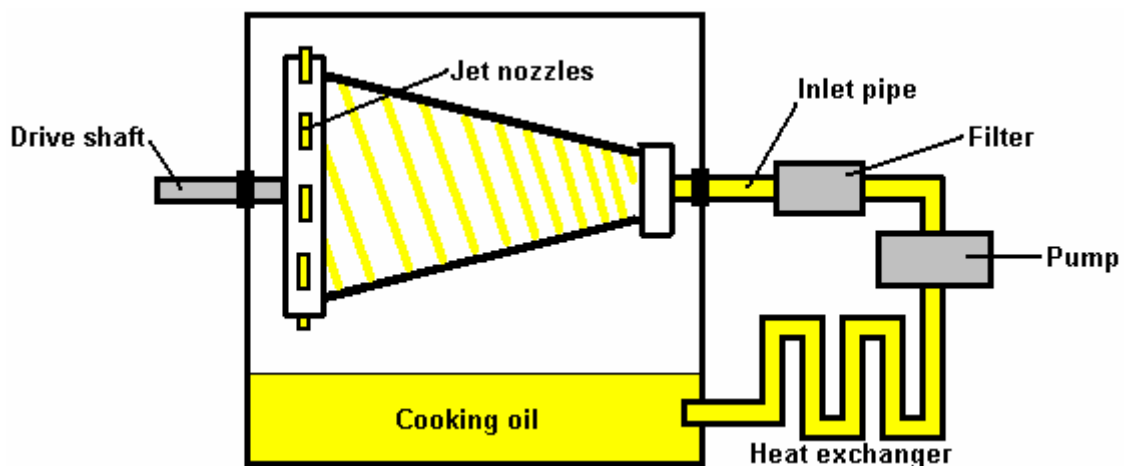

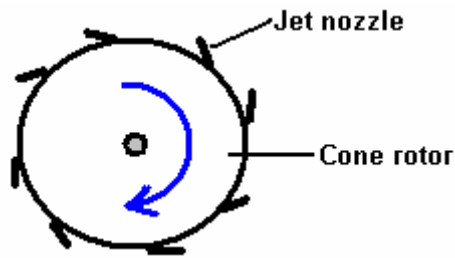

The operating pressure produced by the pump is 300 to 500 psi. Richard did not attempt to patent his engine as US Patent 3,697,190 "Truncated Conical Drag Pump" granted in 1972 as a liquid-asphalt pump is so close in detail that Richard felt that there was insufficient difference for him to be granted a patent:

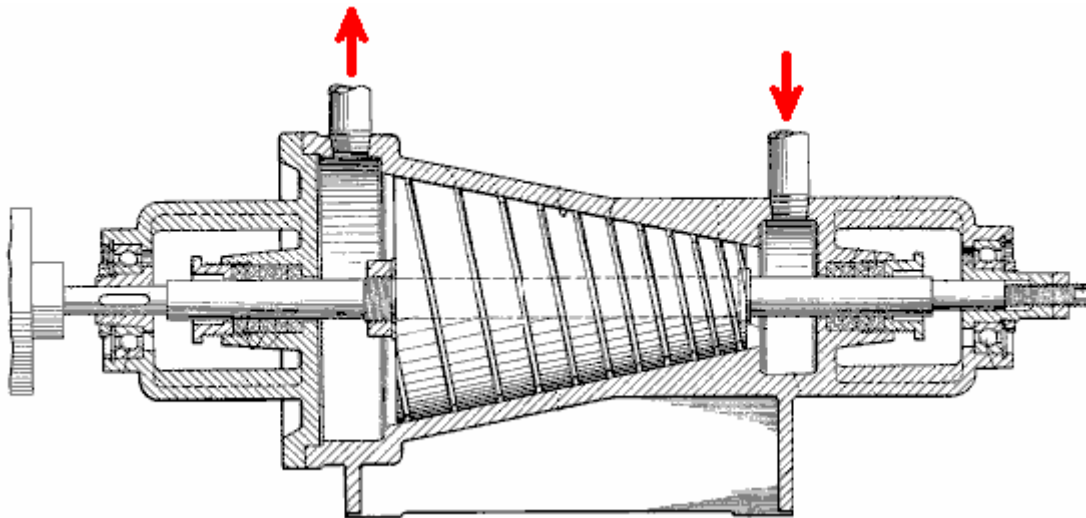

There appears to be considerable scope for anyone who wishes to build or manufacture this engine and it is capable of acting as a heater as well as device for producing mechanical power. This suggests that water purification could be an additional "extra" option for this engine.

Prof. Alfred Evert of Germany has produced an analysis of the operation of the Clem Engine and turbines in this general category. His website <http://evert.de/indefte.htm> has a good deal of information on the subject.

Josef Papp's Inert Gas Engine Conversion.

The Hungarian, Josef Papp, invented an unusual engine system which genuinely appears to be very nearly "fuel-less". His design modifies an existing vehicle engine to operate on a fixed amount of gas. That is to say, the engine has no air intake and no exhaust and consequently, no inlet or exhaust valves. The engine cylinders contain a mixture of gases which have an Atomic Number below 19, specifically, 36% helium, 26% neon, 17% argon, 13% krypton, and 8% xenon by volume. The control system causes the contained gas to expand to drive the pistons down the cylinders and then contract to suck the pistons back up the cylinders. This effectively converts the engine into a one-stroke version where there are two power strokes per revolution from every cylinder.

A small amount of radioactive material is used in the engine, and I have seen it suggested that the engine should be screened to protect the user from radiation. I'm not sure that this is correct, but if it is, then it suggests that a matter to energy conversion is indeed taking place. It seems most unlikely that the minor amount of radioactive material in the engine itself could cause any significant radiation. The patent describes the material as "low-level" which suggests to me, material no more dangerous than the luminous paint that used to be used on the hands of clocks and watches.

Suitable engines must have an even number of cylinders as they operate in pairs. Josef's first prototype was a four-cylinder, 90 horsepower Volvo engine. He removed the intake and exhaust components and

replaced the engine head with his own design. During a thirty-five minute test in a closed room, the engine generated a constant 300 horsepower output at 4,000 rpm. The electrical power needed to run the engine was produced by the standard engine alternator, which was also able to charge the car battery at the same time. Interestingly, an engine of this type, quite apart from having zero pollution emissions (other than heat), is quite capable of operating under water.

Josef, a draftsman and ex-pilot, emigrated from Hungary to Canada in 1957 where he lived until his death in April 1989. There is solid evidence that Josef built an engine of over 100 horsepower (75 kilowatts) that was "fuelled" by a mixture of inert (or "noble") gases. With no exhaust or cooling system, it had huge torque even at low rpm (776 foot-pounds at only 726 rpm in one certified test). Dozens of engineers, scientists, investors and a Federal judge with an engineering background saw the engine working in closed rooms for hours. This would not have been possible if the engine had been using fossil fuel. There was absolutely no exhaust and no visible provision for any exhaust. The engine ran cool at about 60°C (140°F) on its surface, as witnessed by several reliable observers. All these people became convinced of the engine's performance. They all failed to discover a hoax. Ongoing research in the United States (totally independent of Papp) has proved conclusively that inert gases, electrically triggered in various ways, can indeed explode with fantastic violence and energy release, melting metal parts and pushing pistons with large pressure pulses. Some of the people performing this work, or who have evaluated it, are experienced plasma physicists. Contemporary laboratory work has established that inert gases can be made to explode

In a demonstration on 27th October 1968 in the Californian desert, Cecil Baumgartner, representing the top management of the TRW aerospace corporation and others witnessed the detonation of one of the engine cylinders. In full public view, just a few cubic centimetres of the inert gas mixture was injected into the cylinder using a hypodermic needle. When the gas was electrically triggered, the thick steel walls of the cylinder were burst open in a dramatic way. William White, Edmund Karig, and James Green, observers from the Naval Underseas Warfare Laboratory had earlier sealed the chamber so that Papp or others could not insert explosives as part of a hoax. In 1983, an independent certification test was carried out on one of the Papp engines. Joseph Papp was issued three United States patents for his process and engines:

US 3,680,431 on 1st August 1972 "Method and Means for Generating Explosive Forces" in which he states the general nature of the inert gas mixture necessary to produce explosive release of energy. He also suggests several of the triggering sources that may be involved. It appears that Papp is not offering full disclosure here, but there is no doubt that others who have examined this patent and followed its outline have already been able to obtain explosive detonations in inert gases.

US 3,670,494 on 20th June 1972 "Method and Means of Converting Atomic Energy into Utilisable Kinetic Energy" and

US 4,428,193 on 31st January 1984 "Inert Gas Fuel, Fuel Preparation Apparatus and System for Extracting Useful Work from the Fuel". This patent shown here, is very detailed and provides information on building and operating engines of this type. It also gives considerable detail on apparatus for producing the optimum mixture of the necessary gasses.

At the time of writing, a web-based video of one of the Papp prototype engines running on a test bed, can be found at <http://video.google.com/videoplay?docid=-2850891179207690407> although it must be said that a good deal of the footage is of very poor quality, having been taken many years ago. The video is particularly interesting in that some of the demonstrations include instances where a transparent cylinder is used to show the energy explosion. Frame-by-frame operation on the original video shows energy being developed outside the cylinder as well as inside the cylinder, which does seem to suggest that the zero-point energy field is involved. I have recently been contacted by one man who attended some of the engine demonstrations run by Papp and he vouches for the fact that the engine performed exactly as described. Other videos of the Papp engine are located at <http://www.pappengine.com/videos.htm>.

Papp's Patent US 4,428,193 is shown in full in the Appendix.

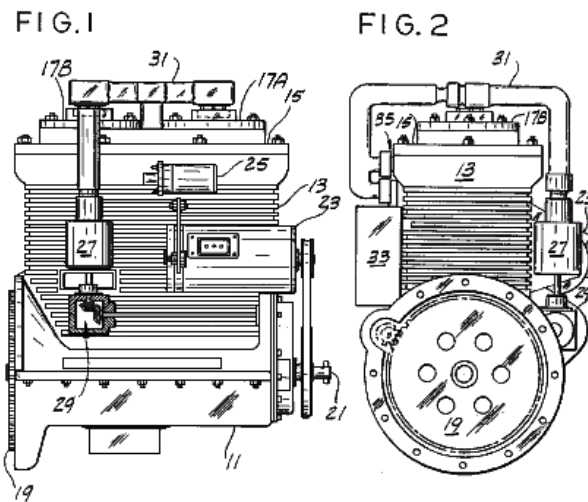

Josef never managed to get his engine design into commercial production before his death, primarily due to the opposition of vested interests. However, his design principles have been picked up and advanced by John Rohner and Haik Biglari.

The "Plasmic Transition Process" is the subject of various patents pending by PlasmERG Inc. of Iowa. John Rohner founded this company in 2008 to be the means to disseminate, develop and license this technology to other motor manufacturers for their own use. This process originally called the "Papp Engine" did run in 1982 and was then lost until John, and his partner Haik Biglari rediscovered it and applied modern science to the system to explain the process and filed their patents, presently pending. The original process was based on information originally patented by the late Joseph Papp, whose patents have now expired. John Rohner, a well known new-product design engineer, was originally contacted in 1979 by his brother Robert, with a schematic for the controller which Papp had designed. Unfortunately, John was busy with several other projects so he turned it over to his brother Tom.

PlasmERG has designed two motors for Own-Equipment-Manufacturers to use. One is an opposed, 2-cylinder, 120 cubic inch engine which produces some 300 horsepower. The second is a 6-cylinder 360 cubic inch engine which can produce around 1,500 horsepower. These motors are being co-developed with a sister company in Canada. John Rohner has personally provided the total investment for this development. As the company moves toward manufacturing, they are seeking investment partners by trading stock for investment. Their first commercial manufacturing plant will cost about 10 million dollars.

An alternative strategy is to create licenses for existing car and truck motor manufacturers until they can fund their own production. The current plan is to provide 500 to 1,000 test sites in underdeveloped nations for water pumping and power generation as "humanitarian" test sites. This should allow the time needed to get production understood and patents completed.

The expected run time of a motor from a single inert gas charge is over 3 months of continuous operation and gas re-charge should cost less than US \$50. John stresses that the PlasmERG motor is **not**, (just as the original Papp engine was **not**), a "Pulsed Plasma motor". Plasma is not retained and "pulsed" as some people have supposed. What actually happens is that the plasma is recreated with each power stroke and then returns to a steady state gas on each return stroke, from which the name "Plasmic Transition" is derived.

The initial power and creation of plasma for expansion, is produced by a fusion event with a side-effect of a limited "chaotic" fission event causing a "plasmic transition" which is contained in a sealed 2-cycle rotating crankshaft motor.

There are two parallels to Plasmic Transition and power production of this motor. The first is natural lightning, which uses an almost identically similar Plasmic Transition process; and the second is steam which provides the same torque over rotational speed event characteristics. There is nothing in the ordinary internal combustion motor's operation that is comparable to either of these processes. The most crucial part of PlasmERG's motor operation is the Electronic Control System (ECS), comprising the following elements:

- Programmable micro computers;
- Radio frequency power generator;

HV spark coil initiation driver;

Various electromagnetic coil voltage switches providing base (resting) or variable (engine speed) voltages for all cylinder or reaction chamber electromagnetic coils;

On-controller DC to 12 volt DC converter;

Engine speed DC voltage (accelerator) to programmed variable voltage DC converter,

Inter controller communications port;

Instrument support for user panel and action port which receives commands from the user comprising by not limited to things like Run, Start, Throttle position, Hold speed, Brake application, Brake hard, various motor inputs and fuel container information.

The PlasmaERG's website is at <http://plasmerng.com/> but it needs Internet Explorer to display properly as it has major display problems when Firefox is used.

John Rohner's Patent Application US 2011/0113772 A1 entitled "Plasmic Transition Process Motor" can be downloaded from www.freepatentsonline.com or from www.free-energy-info.com. It shows a 2-cylinder motor as an example of the operation:

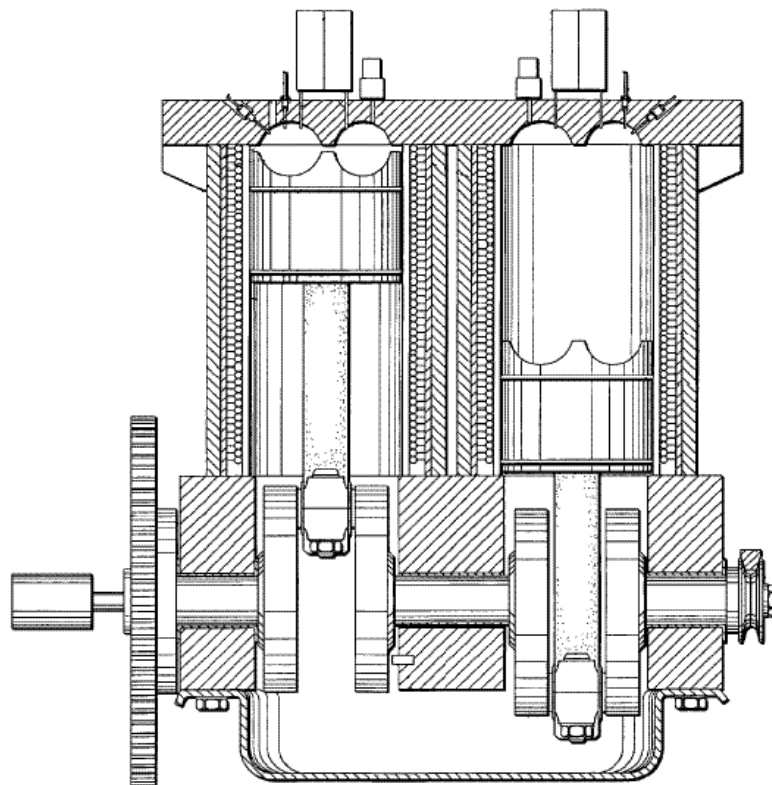

Robert Britt's Inert Gas Motor.

Robert Britt designed a very similar engine to that of Josef Papp, and he was also awarded a US patent for an engine operating on inert gasses. William Lyne remarks that this engine design may be replicated using a Chevy "Monza" 6-cylinder engine or a Volkswagen 4-cylinder engine. The heads are removed and the new heads cast using the "pot metal" used for "pseudo chrome" automotive trim. That alloy contains aluminium, tin, zinc and possibly antimony and is particularly suitable as the insides of the cavities can be polished to the high reflectivity specified in the patents.

A full copy of Robert Britt's patent US 3,977,191 is in the Appendix.

Michael Eskeli's Turbines.

In April 1989, Michael Eskeli was annoyed by a newspaper article published in the Dallas Times Herald which commented on the failure of science to come up with alternative power systems which do not rely on

petroleum products to operate. Michael responded in a letter to the Editor, stating that he holds patents for fuel-less power generators, work-free heat pumps, and other related items, 56 patents issued in the mid-70s.

Michael does hold many patents, one of which is shown in Chapter 14, as a work-free fuel-less heater. However, as I am not aware of any working prototype being shown, I must recommend that you consider the following information as “an idea” rather than a proven fact. As far as I am aware, in the 1970s, the US Patent Office did not demand to see a working prototype before granting a patent, especially if the patent related to a device based on accepted Engineering principles.

However, as Michael's claim is for self-powered devices, his claim seems too important to be ignored, prototype or no prototype, as competent people reading this may well understand the principles suggested and be in a position to build a self-powered device as a result. If that is the case, then I should really appreciate feedback information on any successful replications and the construction methods used.

As I understand it, Michael's self-powered devices are Heat Pumps where the additional energy is flowing from the heat contained in the air, courtesy of the heating effects of sunshine. Standard engineering, but with a design which utilises this available energy to provide practical mechanical output power for vehicles and electrical generators.

The Eskeli patents which I have been able to locate are:

3,650,636 Rotary Gas Compressor
3,719,434 Rotary Ejector Compressor
3,748,054 Reaction Turbine
3,748,057 Rotary Compressor with Cooling
3,758,223 Reaction Rotor Turbine
3,761,195 Compressing Centrifuge
3,795,461 Compressor with Cooling
3,809,017 Heat and Steam Generator
3,834,179 Turbine with Heating and Cooling
3,854,841 Turbine
3,861,147 Sealed Single-rotor Turbine
3,874,190 Sealed Single-rotor Turbine
3,879,152 Turbine
3,889,471 Dual-rotor Dual-fluid Turbine
3,895,491 Turbine with Dual Rotors
3,919,845 Dual-fluid Single-rotor Turbine
3,926,010 Rotary Heat Exchanger
3,931,713 Turbine with Regeneration
3,933,007 Compressing Centrifuge
3,933,008 Multi-stage Heat Exchanger
3,937,034 Gas Compressor-Expander
3,938,336 Turbine with Heating and Cooling
3,939,661 Power Generator
3,949,557 Turbine
3,961,485 Turbine with Heat Intensifier
3,962,888 Heat Exchanger
3,972,194 Thermodynamic Machine of the Vane Type
3,972,203 Rotary Heat Exchanger
3,981,702 Heat Exchanger
3,986,361 Turbine with Regeneration
4,003,673 Fluid Pressuriser
4,005,587 Rotary Heat Exchanger with Cooling and Regeneration *
4,012,164 Rotor with Recirculation
4,012,912 Turbine
4,030,856 Rotor with Jet Nozzles
4,044,824 Heat Exchanger
4,047,392 Dual Rotor Heat Exchanger *
4,050,253 Thermodynamic Machine
4,057,965 Thermodynamic Machine with Step-type Heat Addition
4,060,989 Thermodynamic Machine with Step-type Heat Exchangers
4,068,975 Fluid Pressuriser
4,077,230 Rotary Heat Exchanger with Cooling

- 4,106,304 Thermodynamic Compressor
- 4,107,944 Heat Pump with Two Rotors *
- 4,107,945 Thermodynamic Compressor
- 4,124,993 Refrigeration Machine
- 4,167,371 Method of Fluid Pressurisation
- 4,178,766 Thermodynamic Compressor Method
- 4,574,592 Heat Pump with Liquid-Gas working Fluid

And there are presumably 7 others not listed here, to raise the total to the 56 mentioned by Michael. I do not have the expertise to tell which of these may be self-powered just by reading the patent information, which generally does not mention anything along those lines, (the Patent Office staff not believing that COP>1 exists). Practically any of these patents might fit Michael's description, so I will pick the following patents to reproduce here:

- 4,107,944 Heat Pump with Two Rotors (continuing 4,005,587 and 4,047,392)
- 4,012,912 Turbine, and
- 3,931,713 Turbine with Regeneration

US Patent 4,107,944

22nd August 1978

Inventor: Michael Eskeli

HEAT PUMP WITH TWO ROTORS

ABSTRACT

A method and apparatus for generating heating and cooling by circulating a working fluid within passageways carried by rotors, compressing the working fluid in them and removing heat from the working fluid in a heat-removal heat exchanger and adding heat into the working fluid in a heat-addition heat exchanger, all carried within the rotors. The working fluid is sealed in, and may be a suitable gas, such as nitrogen. A working fluid heat exchanger is also provided to exchange heat within the rotor between two streams of working fluid. In one arrangement, the unit uses two rotors, both rotating; in an alternate arrangement, one of the rotors may be held stationary. Applications include air conditioning and heating applications.

US Patent References:

2,490,064	Thermodynamic Machine	Dec 1949	Kollsman
2,490,065	Thermodynamic Machine	Dec 1949	Kollsman
2,520,729	Machine for producing Heat Energy	Aug 1950	Kollsman
2,597,249	Thermodynamic Engine	May 1952	Kollsman
3,470,704	Thermodynamic Apparatus and Method	Oct 1969	Kantor
3,834,179	Turbine with Heating and Cooling	Sep 1974	Eskeli
3,861,147	Sealed Single-rotor Turbine	Jan 1975	Eskeli
3,889,471	Dual-rotor Dual-fluid Turbine	Jun 1975	Eskeli
3,895,491	Turbine with Dual Rotors	Jul 1975	Eskeli
3,919,845	Dual-fluid Single-rotor Turbine	Nov 1975	Eskeli
3,931,713	Turbine with Regeneration	Jan 1976	Eskeli
4,005,587	Rotary Heat Exchanger with Cooling & Regeneration	Feb 1977	Eskeli
4,044,824	Heat Exchanger	Aug 1977	Eskeli

Cross References to Related Applications

This application is a continuation-in-part application of "Dual Rotor Heat Exchanger" filed Nov. 18, 1973, Ser. No. 407,665, now U.S. Pat. No. 4,047,392.

This application also is a continuation-in-part of "Heat Pump" filed June 30, 1975, Ser. No. 591,881, now abandoned.

And this application also is a continuation-in-part of "Rotary Heat Exchanger with Cooling and Regeneration" filed Oct. 1, 1975, Ser. No. 618,456, now U.S. Pat. No. 4,005,587.

BACKGROUND OF THE INVENTION

This invention relates generally to devices for heat transfer from a lower temperature to a higher temperature by using a working fluid enclosed within a centrifuge rotor as an intermediate fluid to transport the heat.

Heat pumps have been known in the past but are complex and costly, and usually use a working fluid that is evaporated and condensed, which results in poor efficiency, and thus high energy cost.

SUMMARY OF THE INVENTION

It is an object of this invention to provide apparatus that is low in initial cost and has high thermal efficiency thus reducing cost of the power required to run it. It is further the object of this invention to provide a device and process wherein the losses that normally occur in bearings and seals, due to friction, are applied to the working fluid for its circulation, thus in effect eliminating the power loss due to such friction losses. Also, it is an object of this invention to provide the rotor with a working fluid heat exchanger to reduce needed rotor speeds.

BRIEF DESCRIPTION OF THE DRAWINGS

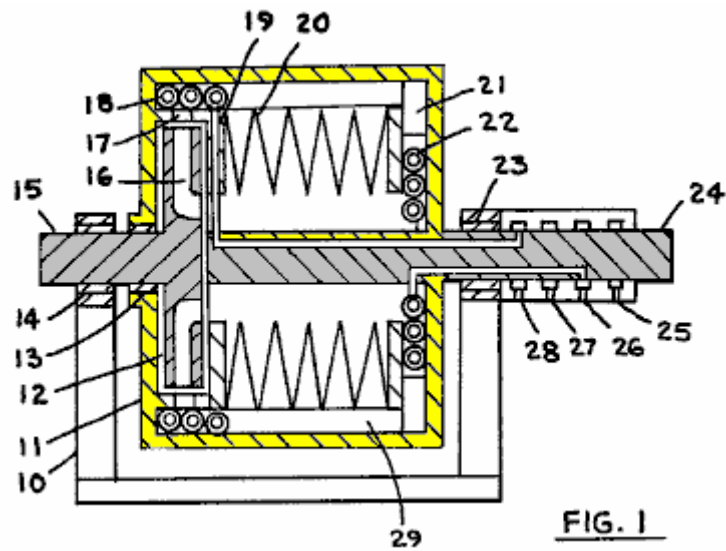

Fig.1 is a cross section of the device.

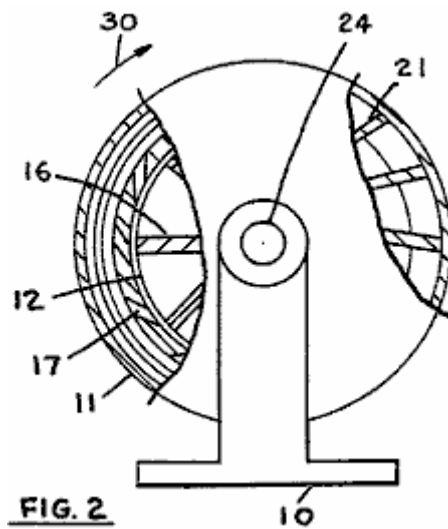

Fig.2 is an end view of the device.

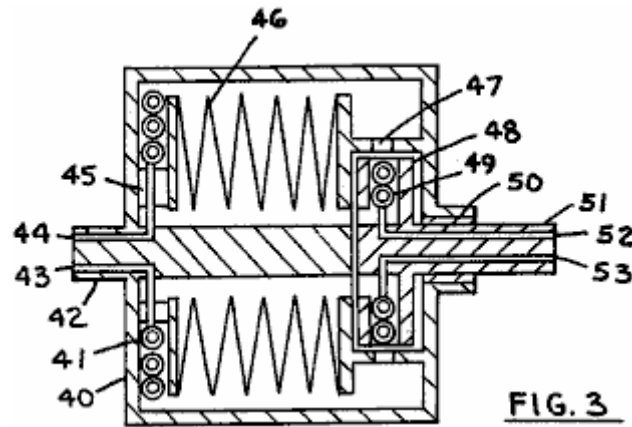

Fig.3 is an axial cross section of another form of the device.

DESCRIPTION OF PREFERRED EMBODIMENTS

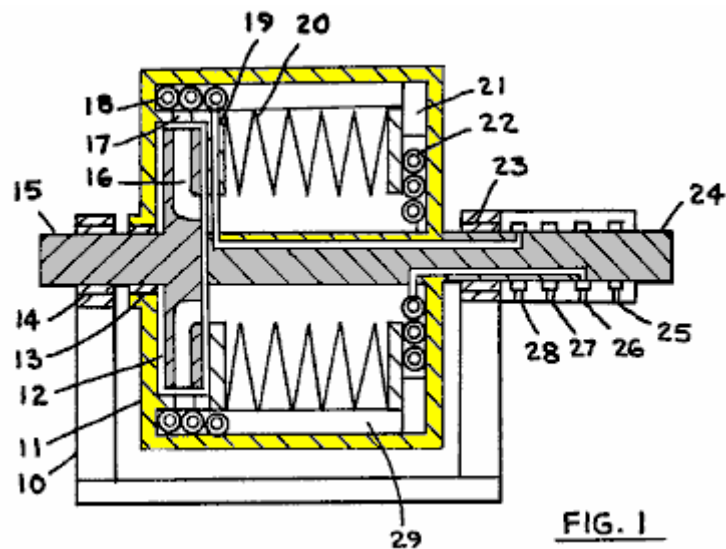
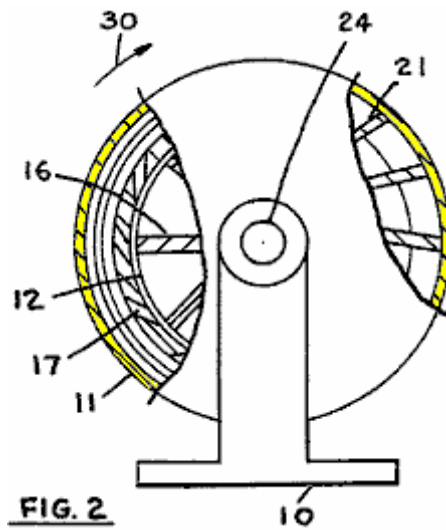
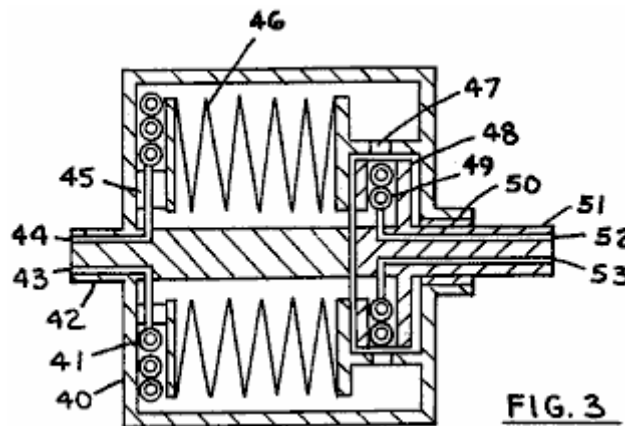

Fig.1 shows an axial cross section of the device, where 10 is the base, 11 is the first rotor, 12 is the second rotor, 13 is a seal and 14 is the bearing supporting shaft 15, 16 is fluid passage in the second rotor, 17 is the

working fluid opening which may be a nozzle, **18** is the first heat exchanger for heat removal from working fluid, **19** is first heat transfer fluid conduit, **20** is working fluid heat exchanger, in this instance formed from sheet metal like bellows, **21** are vanes, **22** is second heat exchanger for heat addition to working fluid, **23** is bearing supporting shaft **24**, **25** and **26** are entry and exit for second heat transfer fluid, **27** and **28** are entry and exit for first heat transfer fluid, and **29** is a vane in peripheral passage.



In **Fig.2**, an end view of the unit shown in **Fig.1** is illustrated. Where **10** is base, **11** is first rotor, **17** are fluid openings, **12** is second rotor, **16** are second rotor fluid passages with vanes, **30** indicates direction of rotation, **24** is first rotor shaft, and **21** are vanes.



In **Fig.3**, the rotors are arranged differently, but perform the same functions, approximately, as in the unit of **Fig.1**. Where **40** is first rotor, **41** is first heat exchanger for heat removal from first fluid, **42** is first rotor shaft, **43** and **44** are entry and exit for first heat transfer fluid, **45** is conduit, **46** is working fluid heat exchanger, **47** are fluid openings which may be nozzles, **48** is second rotor, **49** is second heat exchanger for adding heat to the working fluid, **50** is bearing and seal, **51** is second rotor shaft, **52** and **53** are entry and exit for second heat transfer fluid.

In operation, the rotors are caused to rotate and the rotor cavities are filled with a suitable working fluid, which is usually a gas, such as nitrogen, air or other gaseous or vapour substance. Referring to **Fig.1**, the second rotor rotates usually faster than the first rotor, and the working fluid is compressed by centrifugal force in passages **16**, and in the first rotor to some extent, after which heat is removed in heat exchanger **18**, with such heat then being transported by the first heat transfer fluid out of the device. The working fluid then passes along the peripheral passage **29** and releases heat in heat exchanger **20**, after which the fluid is expanded against centrifugal force in vanes **21** and in heat exchanger **22** where heat is added to the working fluid. After expansion, the working fluid passes along centre passage and receives heat from heat exchanger **20**, thus completing its work cycle.

The operation of the unit in **Fig.3** is similar, except that the second rotor usually rotates slower than the first rotor, and the second rotor may be kept stationary, if desired. Note that if the second rotor is held stationary, one may use dirty water as the second heat transfer fluid; normally, in rotating heat exchangers,

the heat transfer fluid must be free of solids, which will collect in the heat exchanger due to centrifugal force, and block the heat exchanger, and by having a stationary heat exchanger, ordinary water may be used, such as water from a cooling tower.

In the unit of **Fig.1**, the power input is normally to the second rotor, and the first rotor is allowed to rotate freely. In such usage, the rotor diameters are selected to provide, together with the friction loss in bearings, for the needed speed differential between the two rotors. With the second rotor rotating faster, necessary push for the working fluid is provided to keep the working fluid circulating. Alternately, the speed differential may be maintained by using a power transmission between the two rotors, such as a gearbox. In the unit of **Fig.3**, the second rotor speed is slower than the speed of the first rotor, and where the rotor diameters are suitable, the second rotor may be held stationary, providing needed push for the working fluid for its circulation.

The working fluid heat exchanger **20** and **46**, employ centrifugal force and varying gas density to obtain heat exchange between the two working fluid streams. Hot gas in the peripheral passage is lighter, and colder gas between the folds of the heat exchanger is colder, thus the cold gas is displaced by lighter gas by centrifugal force. Similarly, at the centre passage, cold gas at centre displaces hot gas between folds. Other types of heat exchangers may be used for the heat exchanger **20**, including heat pipes, sheet metal discs, and finned tubing filled with a liquid.

The rotor may be encased within a vacuum tank, if desired, to reduce friction on rotor outer surfaces. The use of the working fluid heat exchanger **20** will reduce required rotor speeds to obtain required temperature differentials between the two heat transfer fluids, which then reduces friction losses on the rotor, which may eliminate the need for a vacuum tank.

Various modifications of this device may be made, and different types of heat exchangers used. Also, working fluid radial passages may be curved in various directions, one being the slope for vanes shown as item **21** in **Fig.2**. By using vane slopes and sloped passages, one can adjust the amount of work exchange between the working fluid and the rotor. Nozzles **47** are usually positioned so as to discharge backwards, in order to generate some torque on the first rotor, and similar nozzles may also be used in passages **21** of the unit shown in **Fig.1**. Further, the heat exchanger **22**, of **Fig.1**, may be mounted on a stationary member, if desired, in manner shown in **Fig.3**, and heat exchanger **18** may be mounted within rotor **12**, if desired. The various components of the units may be interchanged, as desired.

CLAIMS

1. In a heat pump wherein a compressible working fluid is circulated radially outwardly in a first fluid passage, said first passage contained in a first member, and radially inwardly towards centre of rotation in a second fluid passage, said second passage contained in at least one of said first and second members, said first and second members coaxially arranged, at least one of said members being supported by a shaft for rotation;
said first and said second radial working fluid passages communicatingly connected at their respective outward ends by an outer passage and at their respective inward ends by an inner passage, said radial and outer and inner passages forming a closed loop extending at least partially through both of said members, a working fluid adapted to be circulating through said loop, means for compressing said working fluid by centrifugal force within said loop with accompanying temperature increase, first heat exchange means for cooling said working fluid after compression, said first heat exchange means being carried by one of said members, a second heat exchange means, carried by one of said members, for regeneratively exchanging heat between said working fluid within said inner and outer passages, and a third heat exchange means carried by one of said members for heating said working fluid after said heat exchange between said working fluid within said inner and outer passages.
2. The heat pump of claim 1 wherein a first heat transfer fluid is circulated within said first heat exchange means to remove heat with said first heat exchange fluid entering and leaving via conduits near the centre of rotation of said members.
3. The heat pump of claim 1 wherein a second heat transfer fluid is circulated within said third heat exchange means entering and leaving via conduits near the centre of rotation of said members.
4. The heat pump of claim 1 wherein both of said members are rotors.
5. The heat pump of claim 4 wherein the two rotors rotate at different angular speeds.
6. The heat pump of claim 1 wherein at least one of said members is a rotor.

7. The heat pump of claim 6 wherein said second heat exchange means includes a plurality of folds.
8. The heat pump of claim 7 wherein said second heat exchange means is of bellows configuration.

US Patent 4,012,912

22nd March 1977

Inventor: Michael Eskeli

TURBINE

ABSTRACT

A method and apparatus for the generation of power wherein a working fluid is compressed within outward extending rotor passages, and then passed inward in other rotor passages with accompanying expansion and deceleration, with work being generated by the decelerating fluid. Heat may be added into the working fluid near the rotor periphery, and in closed rotors, heat is removed from the working fluid after expansion. A regenerator may also be used, mounted on the rotor, exchanging heat between two streams of the working fluid. During the deceleration, the working fluid passages are curved backwards, while the working fluid passages for acceleration are usually radial. The working fluid may be either a liquid or a gas, and the heating fluid and the cooling fluid may also be either a liquid or a gas.

US Patent References:

3,761,195 Compressing Centrifuge	Sept 1973	Eskeli
3,834,179 Turbine with Heating and Cooling	Sept 1974	Eskeli
3,926,010 Rotary Heat Exchanger	Dec 1975	Eskeli

Cross References to Related Applications:

This application is a continuation-in-part application of "Turbine," Ser. No. 566,373, filed 4-9-75 now U.S. Pat. No. 3,949,557.

BACKGROUND OF THE INVENTION

This invention relates to power generators where a working fluid is circulated from a higher energy level to lower energy level, generating power.

In my earlier U.S. Pat. Nos. 3,874,190 and 3,854,841, I described a closed and open type turbines, and using centrifuge design. These turbines used forward facing nozzles within the rotor; in the apparatus disclosed here, such nozzles have been replaced by other methods.

SUMMARY OF THE INVENTION

It is an object of this invention to provide a single rotor centrifuge type turbine stage, where vanes or fins, with suitable contours, are used to extract power from the working fluid, using either an open type or a closed type rotor.

BRIEF DESCRIPTION OF THE DRAWINGS

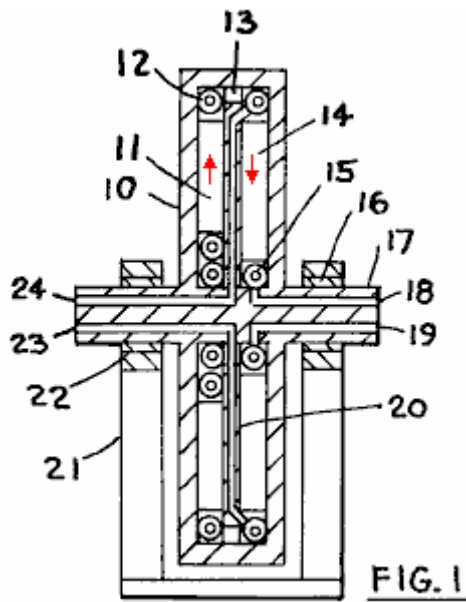

Fig.1 is a cross section and

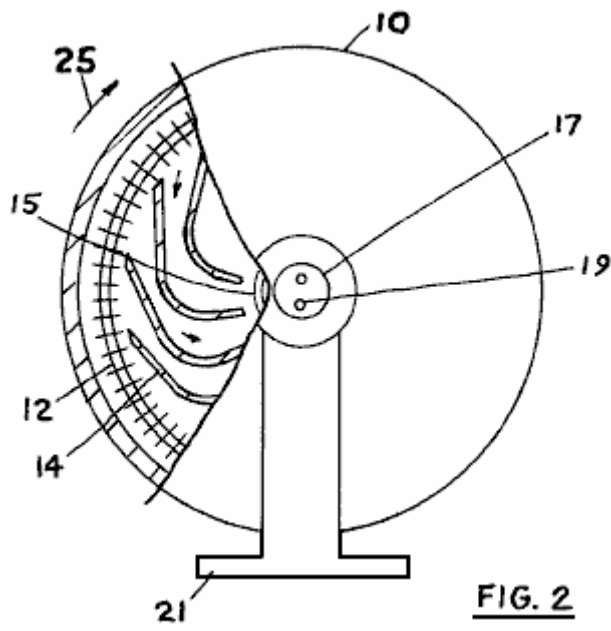

Fig.2 is an end view of a closed type rotor.

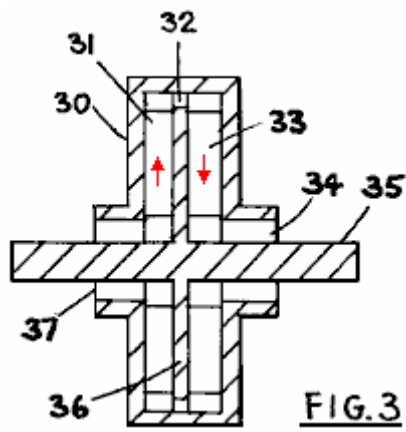

Fig.3 is a cross section and

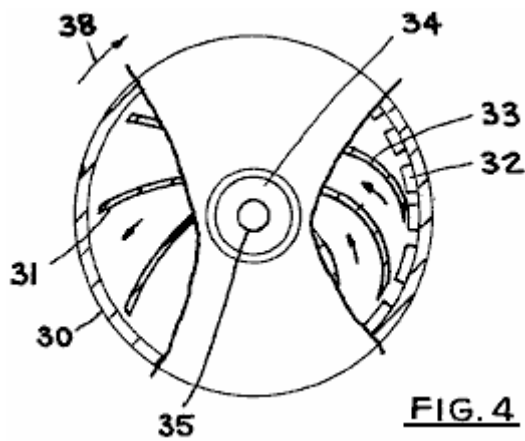

Fig.4 is an end view of an open type rotor.

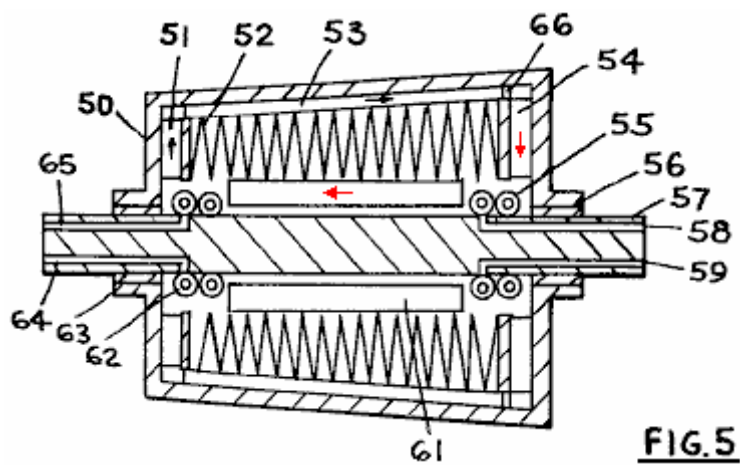
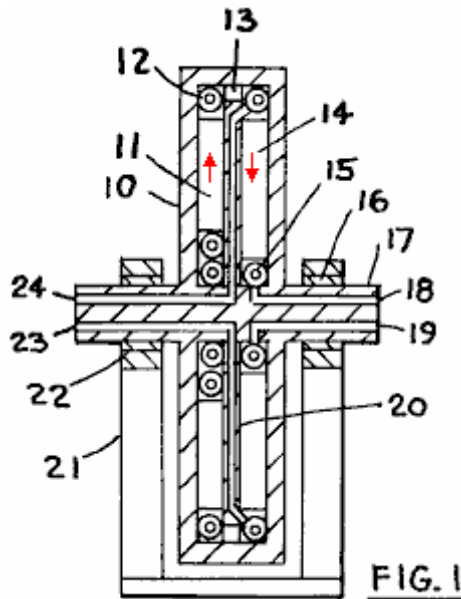

Fig.5 is a cross section of a unit using a closed type rotor and also using a regenerator.

DESCRIPTION OF PREFERRED EMBODIMENTS



Referring to **Fig.1**, there is shown a cross section of one form of the unit. Where **10** is the rotor which is supported by bearings **16** and **22**, shaft **17** and base **21**. **12** is a heat supply heat exchanger and **15** is cooling heat exchanger, **14** and **11** are vanes or fins, **18** and **19** are coolant entry and exit, **20** is a dividing wall, **23** and **24** are heating fluid entry and exit, and **13** is a working fluid passage which may be used to regulate the flow of working fluid within the rotor.

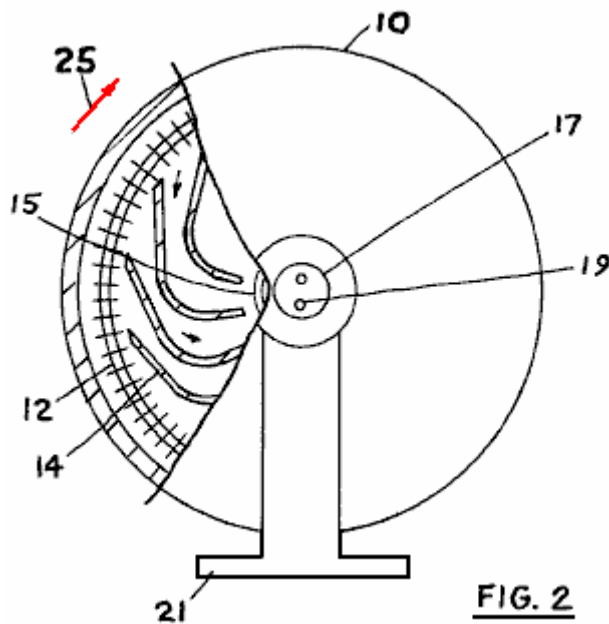

Fig.2 is an end view of the unit shown in **Fig.1**. Where **10** is the rotor, **17** the shaft, **19** is a coolant passage, **21** is the base, **14** are vanes positioned so that they slope away from the direction of rotation as indicated by arrow **25**, while simultaneously passing the working fluid inwards, **12** is the heating heat exchanger, and **15** is the cooling heat exchanger.

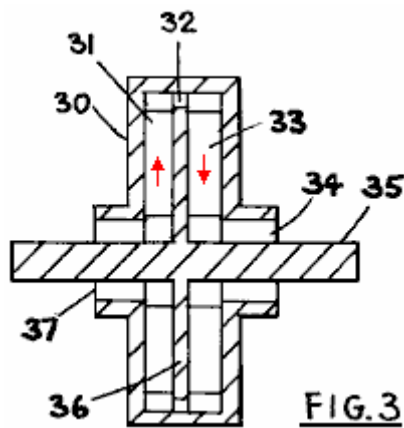

FIG. 3

In **Fig.3**, a rotor for a unit using open cycle is used, where the working fluid enters and leaves the rotor. Here, **30** is the rotor, **31** is the vane situated in a passage which extends outwards, **32** is the fluid passage, **33** is a vane in the passage for inward bound working fluid, **34** is the working fluid exit, **35** is the rotor shaft, **36** is a rotor internal divider and **37** is the working fluid entry into the rotor.

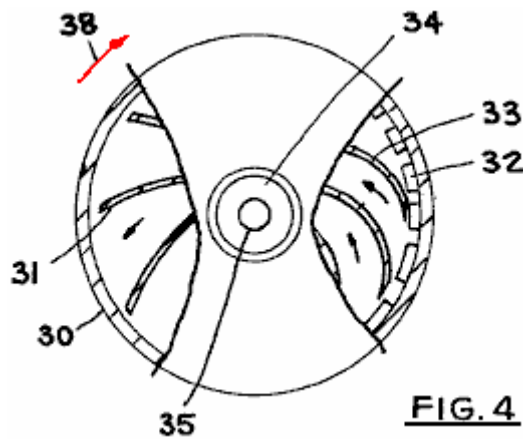

FIG. 4

Fig.4 shows an end view of the unit of **Fig.3** where **30** is the rotor, **35** is the shaft, **31** are vanes in the passages for outward bound fluid, and are shown here to be curved backwards, when the rotor rotates in the direction shown by arrow **38**. After passing openings **32**, the working fluid passes inwards guided by vanes **33**, and then leaving via exit **34**. Vanes **33** are curved as indicated, with the curvature being away from the direction of rotation, so the working fluid provides thrust against the rotor components as it decelerates when passing inwards toward the centre of the rotor.

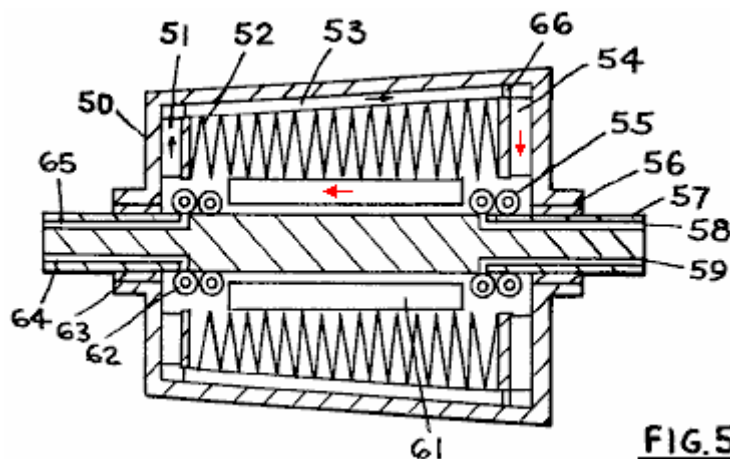

FIG. 5

In **Fig.5**, a rotor with a regenerator is shown, and also the rotor shaft is arranged so that it can be kept stationary if desired. **50** is the rotor which is supported by bearings **56** and **63** and shaft **57**. Vanes **51** may be radial or curved as desired, and vanes **54** are curved in a manner similar to vanes **33** in **Fig.4**. **52** is a

regenerative heat exchanger, exchanging heat between the working fluid streams flowing in passages **53** and **61**. Heat supply heat exchanger **55** and cooling heat exchanger **62** are attached to the shaft, so that the shaft may be kept stationary or rotated at a different speed than the rotor **50**. **58** and **59** are the entry and exit points for the heating fluid while **64** and **65** are the entry and exit points for the cooling fluid, and **66** is an opening.

When operating, the rotor rotates, and a working fluid within the rotor passes outwards in passage **11**, and is compressed by centrifugal force, and accelerated to a tangential speed that may be the same as that for the rotor periphery. In a closed rotor such as is shown in **Fig.1**, heat is added into the working fluid near the rotor periphery, and then the working fluid decelerated in the fluid passages **14** extending inwards toward rotor centre, with the passages being curved backwards away from the direction of rotation as shown in **Fig.2**. As the working fluid is decelerated in the inward extending passages, the work associated by such deceleration is transferred into the rotor and this provides the thrust and torque to rotate the rotor. After deceleration and expansion, the working fluid is cooled in heat exchanger **15** and then passed to the outward extending passages thus completing its working cycle.

The operation of the unit of **Fig.3** is similar, except that the working fluid enters the rotor via opening **37** from external sources. For the unit shown in **Fig.3**, the heat addition heat exchanger is omitted; for this unit, there is a pressure drop between entry **37** and exit **34**. A heat exchanger similar to that shown in **Fig.1**, item **12**, may be used in the unit of **Fig.3**, and then the entry and exit pressure for the working fluid may be the same, if desired.

The operation of the unit shown in **Fig.5**, is similar to that described for the other units. The rotor rotates, and by centrifugal force, compresses the working fluid in passages **51**, and then the working fluid gains heat in the regenerative heat exchanger, with the heat being supplied by another working fluid stream returning from the high temperature end of the unit. The working fluid is expanded and decelerated in passages **54** and heat is added in the heat exchanger **55**. Then the working fluid passes through the regenerative heat exchanger and then is cooled in the cooling heat exchanger and then is passed into passages **51** thus completing its cycle.

The various components of the units shown can be exchanged to make additional forms of the apparatus. As noted, the unit of **Fig.3** may be provided with a heat exchanger similar to that shown in **Fig.1** for adding heat into the working fluid near the rotor periphery. Further, a regenerator may be provided with the units of **Fig.1** and **Fig.3**, if desired, between the outward extending and the inward extending working fluid passages. Also, the cooling coil of **Fig.5**, item **62** may be eliminated, and the working fluid taken into the unit from outside the unit, if desired.

The openings **32**, **13** and **66** may be made into nozzles, if desired, and the nozzle oriented in different directions as desired. In particular, these nozzles may be positioned so as to discharge the working fluid tangentially backwards, if desired.

The regenerator of **Fig.5** is shown to be tapered. This taper may be as shown, or the taper may be made such that the regenerator portion diameter is smaller at the end which has the heat exchanger **55**, than the end which has the heat exchanger **62**. Also, the regenerator may be made without a taper.

Passages **53** and **61** are usually provided with vanes, as indicated in **Fig.5**, to prevent tangential movement of the working fluid.

Applications for this power generator are those normally encountered in power generation.

The working fluid is usually a gas for units such as those shown in **Fig.1** and **Fig.5**, but the working fluid may also be a liquid for a unit such as shown in **Fig.3**. The heating and cooling fluids may be either gases or liquids, as desired.

The heat exchangers for heating and cooling are shown to be made of finned tubing. Other forms of heat exchangers for adding heat and for removing heat may be used. The regenerative heat exchanger is shown to be made of sheet metal; other forms of heat exchangers may be also used.

TURBINE WITH REGENERATION**ABSTRACT**

A method and apparatus for generating power by passing a motivating fluid from a higher energy level to a lower energy level by compressing the fluid in a centrifuge-type first rotor and discharging the fluid via nozzles near the periphery of the first rotor, forwards in the direction of rotation to a second rotor which is an inward flow type reaction turbine, then passing the fluid through a regeneration type heat exchanger to transfer heat from the inward bound fluid into the outward bound fluid, after which the fluid is cooled in a heat exchanger to its original temperature and is passed outward again thus completing its cycle. Heat is added to the fluid near the periphery of the second rotor, or the heat may be added near the periphery of the first rotor, or both. Additionally, the fluid may be supplied to the unit from outside source, and returned to such outside source, and the cooling may thus be eliminated from the unit. Further, the fluid entering from an outside source may be at an elevated pressure. The fluids used may be gaseous, which is normal for a closed type unit, or they may be liquids at entry for the open type unit.

US Patent References:

2,490,064	Thermodynamic Machine	Dec 1949	Kollsman
2,514,875	U-passage Gas Turbine	July 1950	Kollsman
2,597,249	Thermodynamic Engine	May 1952	Kollsman
3,236,052	Closed-cycle Gas Turbines	Feb 1966	Guin
3,530,671	Regenerative Air Turbines	Sep 1970	Kolodziej

This application is a continuation-in-part application of "Turbine with Dual Rotors," Ser. No. 405,628, filed 10/11/73, and uses material of a previous U.S. Pat. No. 3,834,179, "Turbine with Heating and Cooling".

BACKGROUND OF THE INVENTION

This invention relates generally to devices for generating power in response to a fluid flowing from a higher energy level to a lower energy level passing through a turbine for generating the power.

There have been various types of turbines previously, in some of which a fluid is accelerated in a single or multiple stationary nozzles and then passed to vanes mounted on a rotating rotor wheel, where the kinetic energy contained by the moving fluid is converted to power by deceleration of the fluid.

These conventional turbines normally have a high energy loss due to fluid friction, especially between rotor vanes and the fluid where the velocity differential is usually large. Also, these turbines often require complex shaped turbine vanes making the unit costly.

SUMMARY OF THE INVENTION

It is an object of this invention to provide a turbine for power generation in which heat is converted to power, in an efficient and economical manner, and with high thermal efficiency. It is also an object of this invention to provide a means for transferring heat from the motivating or working fluid, which is the first fluid, during its passage from rotor periphery to rotor centre into the first fluid which is passing from the rotor centre towards the rotor periphery. This heat transfer improves the efficiency of the turbine, and reduces the necessary rotational speed of the rotor, allowing less costly rotor construction.

BRIEF DESCRIPTION OF THE DRAWINGS

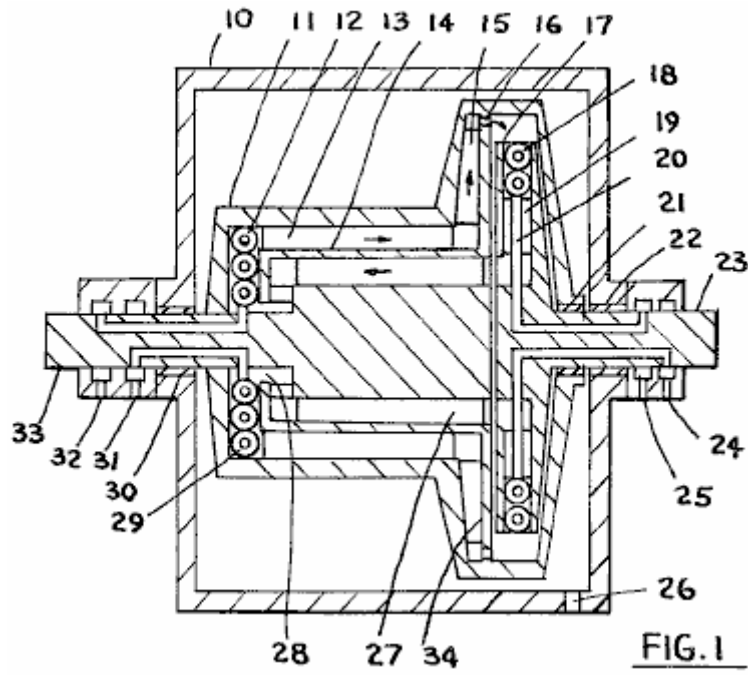

Fig.1 is a cross section of one form of the device, and

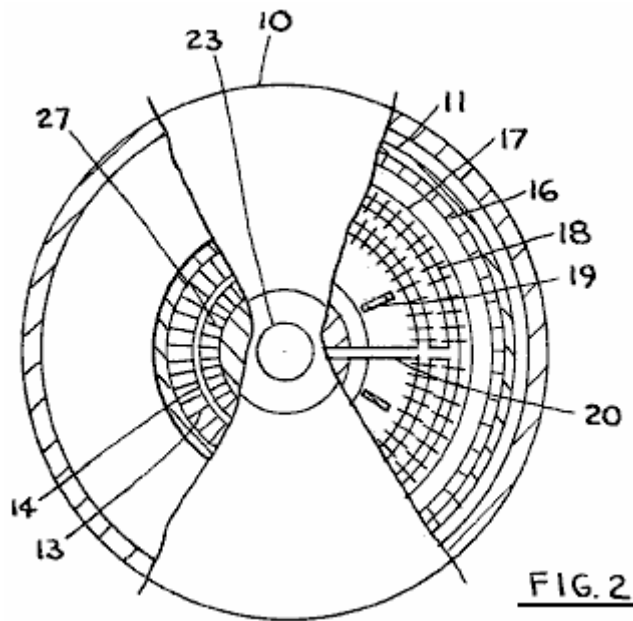

Fig.2 is an end view of the unit shown in Fig.1.

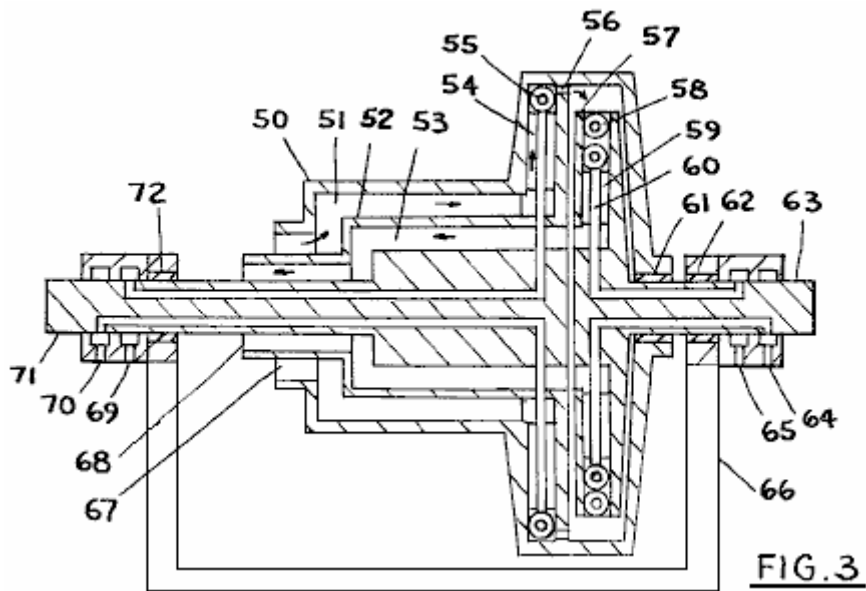

Fig.3 is a cross section of another form of the device.

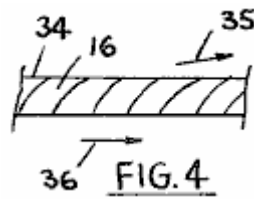

Fig.4 is a detail of rotor nozzles.

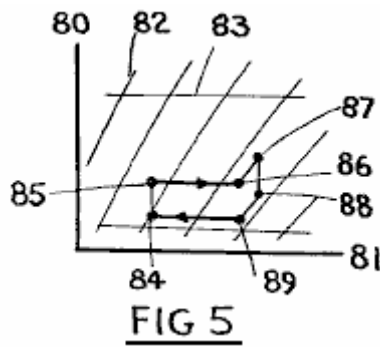

Fig.5 is a pressure-enthalpy diagram of the first fluid with working cycle illustrated for the first fluid.

DESCRIPTION OF THE PREFERRED EMBODIMENTS

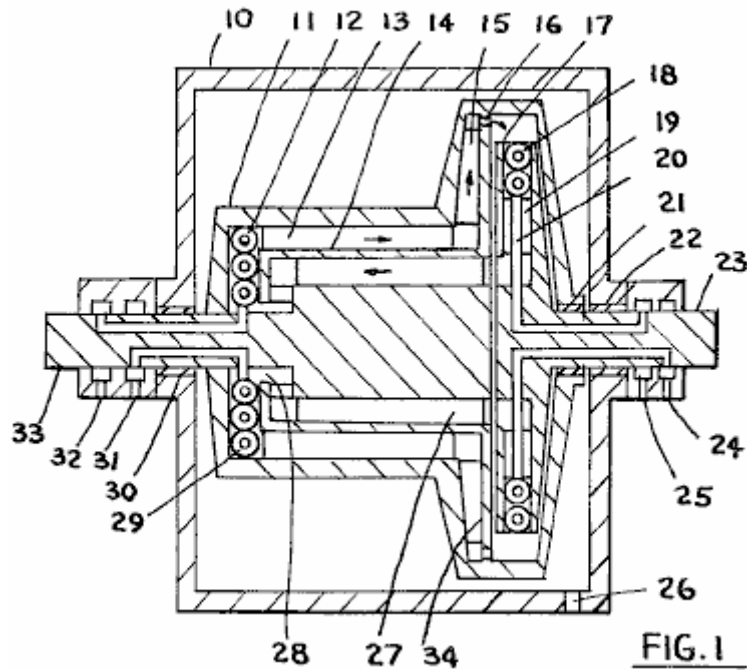

Fig.1 shows a cross section of one form of the turbine. In this form, the first fluid is sealed within the rotor with a second fluid which supplies heat to the first fluid, and a third fluid which cools the first fluid, being circulated from external sources.

The first fluid is accelerated and compressed within the first rotor, and after discharge from the nozzles of the first rotor, into the second rotor, where it receives heat from the second fluid, and after deceleration and expansion the first fluid passes in heat exchange relationship with the first fluid flowing outward so that heat is transferred from the inward bound first fluid to the outward bound first fluid. Cooling is then provided for the first fluid to bring the first fluid temperature to an initial predetermined value.

In **Fig.1**, **10** is the casing, **11** is the first rotor, **12** is the third fluid heat exchanger, **13** is the vane which also serves as a heat exchange member, **14** is a heat-conductive wall, **15** is a vane, **16** is a nozzle, **17** is the second rotor, **18** is the second fluid heat-exchanger, **19** is a vane, **20** is the second-fluid conduit, **21** is a combined bearing and seal, **22** is a combined bearing and seal, **23** is a second rotor shaft for the delivery of power, and for support of the second rotor, **24** and **25** are supply and return for the third-fluid, **26** is a vent opening in the casing into which a vacuum source may be connected, **34** is a dividing wall, **27** are vanes serving also as heat-exchange members, **28** is a first-fluid passage, **30** is a combined bearing and seal, **31** and **32** are the second-fluid entry and exit points, and **33** is the first rotor shaft.

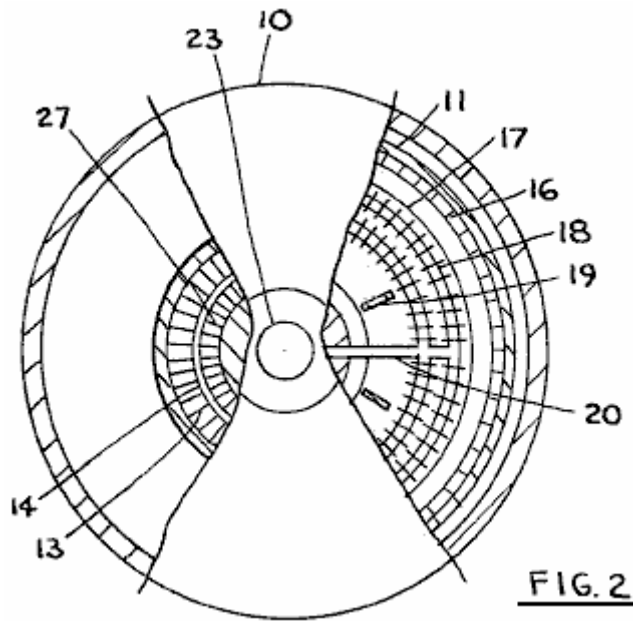

Fig.2 shows an end view of the unit of **Fig.1** where **10** is the casing, **11** is the first rotor, **17** is the second rotor, **16** are the first-fluid nozzles, **18** is a heat exchanger, **19** are vanes, **20** is a conduit, **13**, **14** and **27** form a heat exchanger for the first-fluid and **23** is the second rotor shaft.

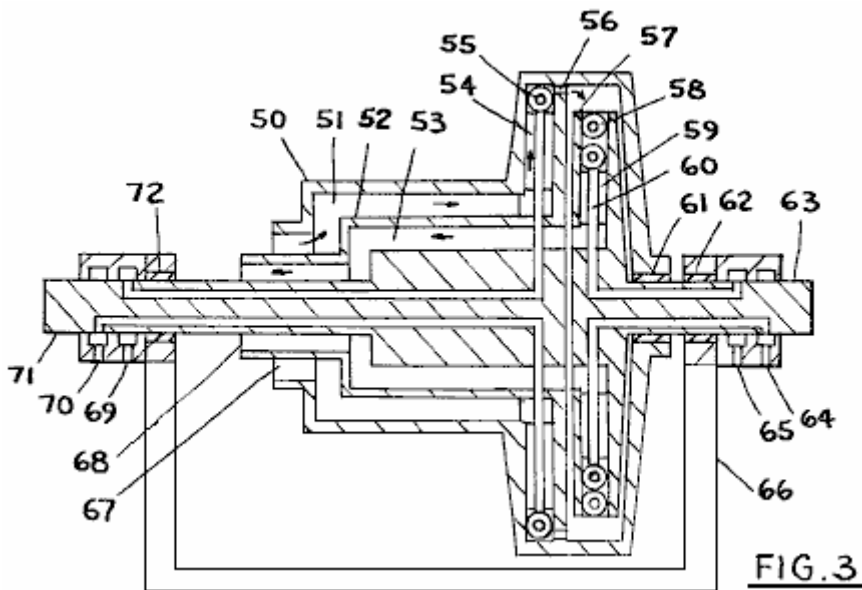

Fig.3 shows another form of the turbine, where the first-fluid is supplied to the turbine from outside sources thus eliminating the third-fluid heat exchanger. **50** is the first rotor, **51**, **52** and **53** form a heat exchanger for the first-fluid, **55** and **58** are heating heat exchangers for adding heat to the first-fluid and may use a second-fluid at the same temperature or at a different temperature as the heating fluid, **54** are vanes within first rotor, **56** are first-fluid nozzles oriented to discharge forwards, **57** is the second rotor, **59** are vanes, **60** is a conduit for the second-fluid, **61**, **62** and **72** are bearings, **64**, **65**, **69** and **70** are entries and exits for the second-fluid, **63** is the second rotor shaft, **71** is first rotor shaft, **66** is the base, while **67** and **68** are the exit and entry points for the first-fluid.

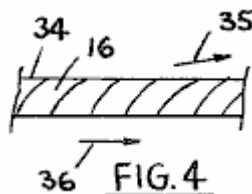
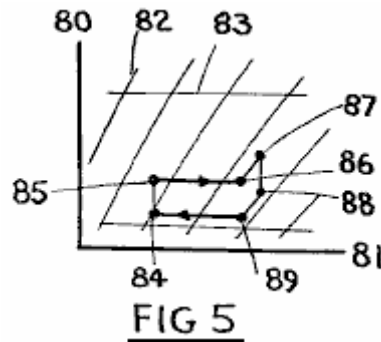

Fig.4 shows a detail of the first-fluid nozzles where **34** is wall on which nozzles **16** are mounted, **35** is the approximate direction of leaving of the first-fluid, and **36** indicates direction of rotation of first rotor.



In **Fig.5**, a pressure-enthalpy diagram for the first fluid is shown, with the working cycle for the first-fluid where **80** is the pressure axis and **81** is enthalpy axis, **82** are constant entropy lines, **83** are constant pressure lines, and for the cycle, compression with heat removal, or without heat removal, occurs from **84** to **85**, heat is added from returning first-fluid from **85** to **86**, further compression is from **86** to **87**, then expansion from **87** to **88** and **89**, and heat removal to the first-fluid from **89** to **84**, thus completing the cycle. Heat is normally added between **87** and **88**, from the second-fluid. The heat addition between **85** and **86**, and heat removal between **89** and **84** may be at constant or varying pressure as desired; pressure may be varied conveniently by increasing or decreasing the diameter of the first-fluid to first-fluid heat exchanger, making the heat exchanger tapered.

In operation, the rotors are filled to a desired pressure with a suitable first-fluid, and the first rotor is caused to rotate. The first-fluid is first compressed with heat removal, and then is passed in heat exchange relationship with the inward bound first-fluid with addition of heat, and after this the first-fluid is further compressed and accelerated and after this compression, the first-fluid is passed via nozzles mounted on the first rotor forwards in the direction of rotation, after which the first fluid enters the second rotor's inward extending passages for deceleration, with heat being added to the first-fluid in the second rotor inward passages for reduction of density of the first-fluid. After passing inwards and decelerating, the first-fluid is passed in heat exchange relationship with the outward bound first-fluid, and after that, the first-fluid may be further decelerated, and then the first-fluid enters the outward extending passages of the first rotor thus completing the cycle.

The operation of the open turbine of **Fig.3** is similar to that described, except that the first-fluid is supplied from external sources, and is then returned to said external source, with cooling then being deleted.

The work input to the first rotor is the work required to accelerate the first-fluid, and the work output by the second rotor is the work of deceleration received by the second rotor. The work output by the turbine is the work differential of these two rotors.

The rotational speed of the second rotor may be higher than the rotational speed of the first rotor. To provide for inward flow of the first fluid within the second rotor, the fluid density is reduced by adding heat to the first fluid either within the second rotor, or also within the first rotor.

The addition of heat from the inward bound first fluid to the outward bound first fluid increases the temperature of the first fluid during latter part of compression and during expansion, and thus has the effect of improving the thermal efficiency of the turbine. Also, another effect is the reduction in the needed rotational speed for the turbine rotors, thus reducing the required strength for the rotors, and making the rotors more economical to make and operate.

Working fluids for this turbine are usually gases for the first-fluid, and liquids for the second and third fluids. Gaseous second and third fluids may be also used, and the first-fluid may be a liquid in some instances. Also, the first fluid may undergo a phase change within the turbine, if so desired, when using a suitable fluid. Applications for this turbine include normal power generation service using various heat sources.

The first rotor shaft and the second rotor shaft are normally connected via a power transmission device so that a part of the power produced by the second rotor is used to rotate the first rotor. Starting of the unit is by a starting device.

The vanes of the rotors may be made curved if desired. In many instances, the first rotor vanes may be curved backward to increase compression of the first-fluid, and the vanes of the second rotor may be also curved, to improve performance, and to suit the design and fluid selected. In this connection, the fins for the heat exchangers are considered to be vanes.

The pressure-enthalpy diagram shown in **Fig.5**, is approximate only. This diagram may be varied, depending of the amount of heat added in the second rotor, or in the first rotor, and depending on the specific location of the second fluid and third fluid heat exchangers. In particular, heat may be added to the first-fluid during expansion to make the first-fluid actually increase in temperature; this will normally improve the overall thermal efficiency of the turbine. Also, heat removal by the third fluid may be conducted in places other than that shown in **Fig.1**, as desired.

It should be also noted that the heat addition to the first-fluid may be from sources other than the second fluid, and similarly, some other means may be used to cool the first-fluid other than the third fluid. Such heating sources may include electricity, or other rotors mounted in proximity to this turbine; these will not change the spirit of this invention.

The heat exchanger mechanism for transferring heat from the inward bound first-fluid to the outward bound first-fluid can also be located within the second rotor, and also the entry and exit for the first-fluid into the turbine may be within the second rotor. Such arrangements are not shown specifically in the drawings since they are considered to be within the capabilities of a skilled designer, in view of the descriptions given herein.

Much of this information on Michael Eskeli is taken, with the kind permission of Scott Robertson, from his web site <http://www.aircaraccess.com> .

James Hardy's Self-Powered Water-jet Generator.

Repeated here from Chapter 2, a device which needs to be in this list of self-powered devices is the ultra simple water-jet generator. There is a video on Google which shows a self-powered electrical water-pump driven, electrical generator at the location: http://video.google.com.au/videoplay?docid=-3577926064917175403&ei=b1_BSO7UDILAIgKA4oCuCQ&q=self-powered+generator&vt=lf

This is a very simple device where the jet of water from the pump is directed at a simple water-wheel which in turn, spins an electrical alternator, powering both the pump and an electric light bulb, demonstrating free-energy. What is of particular note is the utter simplicity of this device. It uses off-the-shelf parts almost exclusively and can be constructed by almost anyone.

It should be noted that the implementation shown in this video uses the most basic of turbine blades which must have a very low efficiency, and yet the output power generated is well above the level needed to sustain its own operation. Given well shaped conventional turbine blades of much higher efficiency would appear to raise the performance further, while one would think that using a Tesla Turbine with its simple discs should give a really spectacular performance. However, this may very well not be the case as the irregular, pulsed drive of the wheel will be leading-out additional energy as in the case of the Chas Campbell flywheel and the John Bedini flywheel. As it is, with its present form of construction, this device is already capable of producing additional power able to run other pieces of standard mains equipment.



This is clearly a development platform and it would benefit from having the areas which contain water, fully enclosed, and the electrical diversion from mains power to the output alternator operated by a switch.



Initially, the generator is got up to speed, driven by the mains electrical supply. Then, when it is running normally, the mains connection is removed and the motor/generator sustains itself and is also able to power at least one light bulb. The generator output is normal mains current from a standard off-the-shelf alternator. Power generation could hardly get any more simple than this.

The Heat Pump System of Arthur Cahill and John Scott.

Arthur Cahill and John Scott have patented a heat-pump system which draws heat energy from the surrounding environment and uses that energy to produce mechanical and/or electrical energy for powering a household. Why most people have a refrigerator they are generally not aware that it is a heat-pump and moves three times as much heat from inside the refrigerator compared to the necessary input power (COP=3 but could be up to COP=11 when used differently).

This heat-pump system appears to run without any form of energy input, but the energy comes indirectly from the sun heating the surrounding environment and there is no magic involved. Mind you, when the system runs and provides power, generally, without the need for any fuel, the user can be forgiven for

thinking of it as a fuel-less or self-powered system even though strictly speaking, that is not the case. The inventors have made allowances for unusual conditions where environmental conditions can't provide the temperature difference needed to make the system operate as intended. A liquid or gaseous fuel is provided along with a burner to provide the heat difference if those conditions are encountered.

Here is an extract from their patent:

Patent US 4,309,619

5th January 1982

Inventors: Arthur Cahill & John Scott

SOLAR ENERGY SYSTEM

ABSTRACT:

A dynamic, self-sustaining and self-perpetuating device for the production of motive force by combining cryogenic and thermodynamic principles into one system, keeping the systems separated, two open to atmosphere, the other closed, sealed, pressurised and using special compounded fluids, which when alternately exposed to the heat of atmospheric temperature, then, to the coldness of a liquid or air-cooled condenser, first evaporates, then condenses. Rapid expansion during evaporation produces a high pressure vapour which operates an engine and a generator, which are an integral part of the closed system. Rapid condensation drastically reduces back pressure on the aft side of the engine, and the engine operates on the difference between the two pressures, producing electricity, or, the engine can be used as a direct drive for vehicles or equipment. Built-in safeguards and alternatives are a part of the systems, assuring continued operation despite adverse conditions.

US Patent References:

2,969,637	Converting solar to mechanical energy	Jan 1961	Rowekamp
3,495,402	Power system	Feb 1970	Yates
3,995,429	Generating power using environmental temperature differentials	Dec 1976	Peters
4,110,986	Using solar energy carried by a fluid	Sep 1978	Tacchi
4,214,170	Power generation-refrigeration system	Jul 1980	Leonard

BACKGROUND OF THE INVENTION

1. Field of the Invention

This invention relates to a closed-cycle, sealed, pressurised, energy producing system, utilising the sciences of thermodynamics and cryogenics to convert liquid into gas, then back to liquid.

2. Description of the Prior Art

There is no exact prior art, as cryogenics have been used primarily for air conditioning and refrigeration purposes, and thermodynamic efforts have been directed in the area of low efficiency ocean thermal energy conversion systems. A few attempts have been made to combine some form of cryogenics and thermodynamics, without notable success, mainly using sea water for evaporation and condensing. While using no fuel and requiring little in the area of labour, these ocean thermal energy conversion systems are of necessity, low pressure systems and require large sea going platforms to support the huge turbines and heat exchangers which are necessary to produce reasonable electrical power, resulting in excessive capital costs for minimal electrical output, since such stations only have the ability to service a small portion of the populace along the seaboards. None of these contrivances serve or benefit the populace as a whole, while the whole bears the burden of financing through taxes, or government grants.

Proposals to heat gases and cool gases in an endeavour to improve the efficiency of home heating and cooling systems, have been previously advanced, some operating on the heat pump principle. All such previous proposals and inventions have had one thing in common, they all plug into the Utility Company's electric line to obtain the electricity necessary to run the system.

In cryogenics the knowledge that certain liquids, when heated, change into a high pressure vapour, which is the heart of all air conditioning and refrigeration systems, has been known for many years. Thermodynamics were pioneered by the 19th century French physicist Nicholas Carnot. Attempts have been advanced during the years to harness one or the other and sometimes both, for the purpose of heating and cooling, resulting

in the invention of the heat pump in a much earlier year, but none of the systems yet devised for use by the general public have been able to operate without the use of an outside source of electricity, or, fuel, such as oil, or gas fired boilers, resulting in a considerable consumption of fuel and a cataclysmic effect on the earth's environment.

SUMMARY OF THE INVENTION

In accordance with the present invention, the device will operate in hot sunshine; on cloudy days without sunshine; during rainstorms; during snowstorms; during changes in temperature from day to night; during changes in seasons from winter, to spring, to summer, to fall; when it's cold, even below zero; for the power generated is that energy produced when a compounded fluid changes form, first to vapour, then back to liquid, by application of controlled temperatures within the sealed cycle. Thus, by combining cryogenics and thermodynamics into one system, keeping the two separated, one open to atmosphere and the other closed, sealed and pressurised, and by using fluids specifically compounded for the given area, or climate, these fluids, when exposed to atmospheric temperatures, in accordance with the kinetic theories of matter, gases and heat, provide the kinetic energy to operate an engine.

The condenser can be either liquid or air cooled, although for the embodiment depicted herein, the condenser is air cooled.

Generally speaking, there is up to an approximate 2.5 PSI increase associated with each degree of temperature rise in most cryogenic fluids and gases. However, using commercially available fluids, here are a few examples:

Temperature F.	Fluid	Pressure in psi.
125	R-22	280
125	R-500	203
125	R-502	299
125	R-717	293
80	R-13	521
80	R-22	145
80	R-500	102
80	R-502	160
80	R-700	128

You will notice that R-13 at 80° F. produces 521 psi., or 35.4 times atmospheric pressure and at 125° F. would produce thousands of psi. At 95° F. R-22 produces 185 psi., or a thrust on a five inch diameter piston of 3,633.4 pounds. Even at 30° F., with R-22 a thrust of 583.2 pounds is obtained. R-13 at 30° F. produces 263 psi. or 5,112.7 pounds of thrust on a five inch diameter piston. The pressures are there by using the Casco Perpetuating Energy System, utilising proprietary formulated liquids for the area and temperatures to be encountered. It is not intended that any of these mentioned fluids will be used in the present invention; the comparisons being made herein with popular and well known liquids, for comparison purposes only.

THE INVENTION

The present invention relates to a device to supply pollution free power to operate a generator for the producing of electrical power, or, to supply power as a direct drive to a shaft, transmission, clutch, differential or the such, the invention being independent of outside sources of power such as electricity supplied by a Public Utility Company. This is not to be considered perpetual motion, as will be explained later in the text.

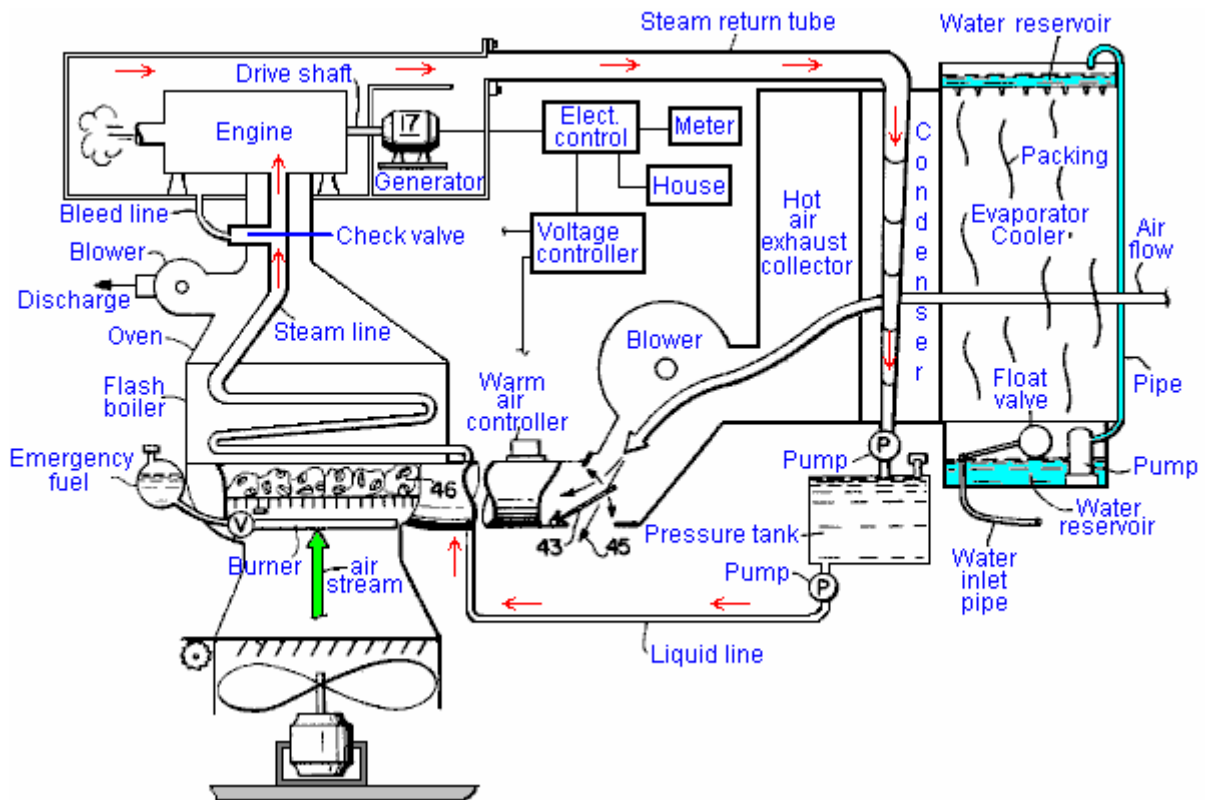

Proprietary liquids, specifically compounded to produce the desired results in a given area, or climate, under pressure in the reservoir to keep them in a liquid state, will, when directed through tubes exposed to atmospheric temperature, change from a liquid state into a gaseous state (from here on referred to as steam), such conversion resulting in tremendous expansion, thus producing high pressure steam with which to drive the engine, or turbine.

It is a general object of this invention to provide a pollution free device for public utilisation, that will produce electrical power or, direct drive power. One object is to produce electrical power with which to heat, cool, cook, run electrical appliances and light a home. Another object of the invention is to provide industry with a pollution free means to not only heat, cool and light factories, but to supply electrical or direct drive power with which to operate factory equipment. A still further object of the invention is to provide a pollution free source of power to propel cars, trains, trucks, buses, equipment, steamships, aeroplanes, and other forms of transportation, without the use of fossil fuels as the primary power source. It is also an object of the present invention to provide the means whereby individuals can produce electrical power for their own use, and as a small power production, sell their surplus electrical power to the local electricity utility company. A further object of the invention is to provide a self-sustaining, small apparatus, that provides ample power from the engine to operate a car or other conveyance, or to supply sufficient electrical power to a home or factory, without having to plug the apparatus into a Public Utility electrical supply.

BRIEF DESCRIPTION OF THE DRAWING

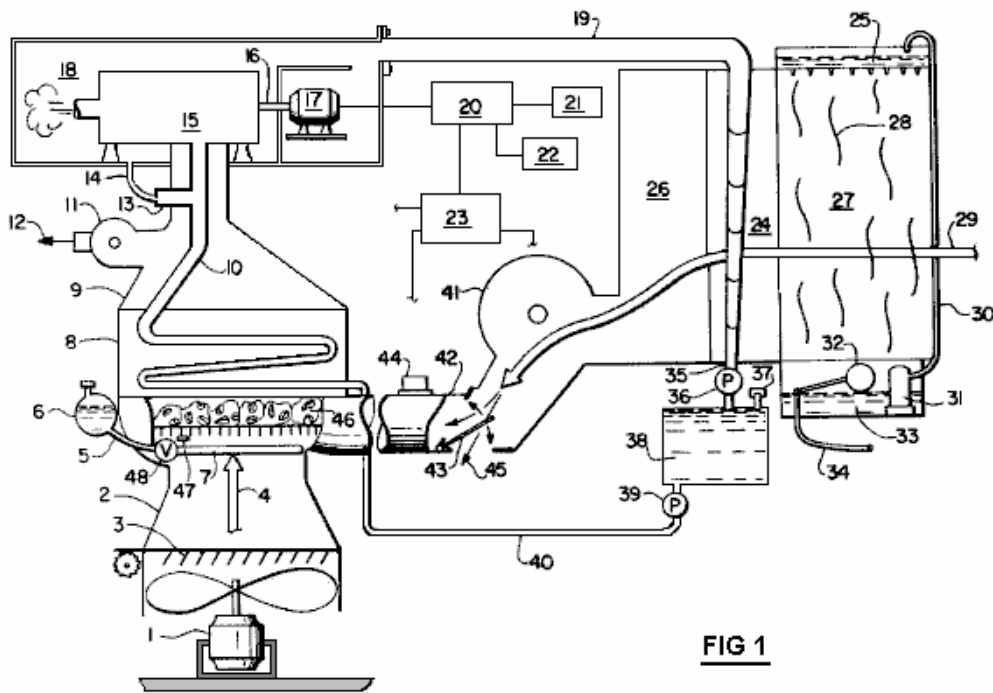

FIG 1

Fig.1 is a partially sectioned schematic view of the system:

DETAILED DESCRIPTION OF A PREFERRED EMBODIMENT

In the drawing, **Fig.1**, the invention is shown in a preferred embodiment for home use. The liquid pump **39**, pumps the cryogenic fluid from the pressurised liquid reservoir **38**, into liquid line **40**, where the fluid gravity feeds into flash boiler **8**. Pump **39** also prevents back pressure from flash boiler **8** from entering the pressurised liquid reservoir **38**, and since the pressure within steam line **10** and liquid line **40** are equal, the cryogenic fluid gravity feeds down liquid line **40** into steam line **10**. The fins on flash boiler **8** are heated to atmospheric temperature by air stream **4**, which converts the fluid within steam line **10**, inside flash boiler **8** into high pressure steam. To maintain the pressure during the passage of steam to the engine **15**, steam line **10** from flash boiler **8** is housed inside the oven **9**, which is exhausted when necessary by discharge **12** from centrifugal blower **11**. Constant temperature within oven **9** and flash boiler **8** is maintained by the admission of fresh atmosphere via air stream **4** passing through the finned flash boiler **8** and up through oven **9**. Centrifugal blower **11** is thermostatically controlled to exhaust air within oven **9** which has cooled below a predetermined temperature. Any excess pressure within steam line **10** is by-passed through check valve **13** and bleed line **14** into the exhaust collector box **18**, thus, a pressurised, closed system is maintained, which, once charged, unless an accident damages or ruptures a line, should not have to be replenished. Pressure within the exhaust collection box **18** will be less than the inlet pressure from steam line **10** to engine **15**, because the condenser **24** is at a lower pressure, as is steam return tube **19**, than PSI input to engine **15** from steam line **10**, thereby creating a suction on the back of the exhaust collector box **18**.

Airstream **29**, which has been cooled by evaporator cooler **27**, flows over the finned surfaces of condenser **24**, instantly lowering the temperature of the steam within condenser **24** below a predetermined condensation point, thus turning the steam back to a liquid, such conversion and instant reduction of volume within condenser **24** causing a pressure reduction at the back of engine **15**. This condensed liquid drains down into liquid coil return **35**, where it is immediately pumped into the pressurised liquid reservoir **38** by liquid pump **36**.

While under pressure in pressurised liquid reservoir **38**, the fluid is maintained in a liquid state regardless of exterior temperature, until it is re-circulated back into the system by liquid pump **39**, through liquid line **40** to flash boiler **8**, where it again converts into steam.

The capacity of evaporator cooler **27** and packing **28** is sufficient to cool intake air stream **29** to a predetermined temperature below atmospheric temperature at any given time, even with humidity rise at night, or during rainstorms, or just during high humidity weather. This temperature differential is maintained as the atmospheric temperature rises and falls, with an anti-freeze liquid being added to the water in the evaporator cooler when temperatures drop below 32° F., to keep it from freezing.

Additional warm air to augment air stream 4 is obtained by directing the warm air exhaust collected in hot exhaust air collector 26, by centrifugal blower 41, through T-assembly 42. Air flow through T-assembly 42 is directed and controlled by the warm air control mechanism 44, which regulates flow-damper 43 to either exhaust through exit 45 into the atmosphere, or alternatively, recirculate air flow 29 through restricted-T 42, thereby compressing and further heating air flow 29 before injecting it through flash boiler 8. Warm air control mechanism 44 also controls fan 1 and louvers 3, selecting the optimum heat from either T-assembly 42 or variable-Venturi 2, to perpetuate the system.

The evaporator cooler 27 has an inlet water pipe 34 which supplies cold water from the normal house water supply, or well, (neither shown). The bottom water reservoir 33 is kept at a constant level of water by float valve 32. The water is pumped by pump 31 up tube 30 into the top water reservoir 25, where it runs through the perforated bottom of reservoir 25 down on to the packing 28, keeping packing 28 constantly wet, which cools air flow 29 as it is drawn through packing 28 and over the fins of condenser 24 by the partial vacuum in the hot air exhaust collector 26, such partial vacuum being created by centrifugal blower 41 exhausting the air from the hot exhaust air collector 26 slightly faster than air flow 29 can replace it.

As long as there is warmer air on the flash boiler 8 side of the system than the cooler condenser 24 side of the system, this device will continue to operate and produce electricity and/or power. The heat recirculating system and the use of three separate, distinct sub-systems within the system, one sealed, permits the system to perpetuate itself. As mentioned above, this device is not to be considered perpetual motion, for somewhere in the ranges of temperature differentials and weather conditions, there may be a no-man's land where the system could shut down, then the variable venturi 2, in conjunction with motor and fan 1 and louvers 3, will come into use automatically upon a signal from warm air controller 44 and 12 voltage controller 23, and be used for a period of time. Motor and fan 1 forces an air stream 4 upward through the variable Venturi 2, with air stream 4 controlled by warm air controller 44 and 12 volt controller 23, adjusting louvers 3. As air stream 4 is forced through the restriction of variable Venturi 2, air stream 4 is compressed as it funnels up the narrowing walls of the variable Venturi 2, such compression causing the air to heat, thus overcoming possible deadlocked or identical temperatures between the condenser 24 and air flow 4. This slight temperature rise in air stream 4 will enable the system to perpetuate itself until the atmospheric temperature itself changes enough to permit a continued operation. Since fan and motor 1 is run by battery power from 12 volt supply 23, even though the batteries are constantly being charged during operation, the batteries may become exhausted because of an extended time the fan and motor 1 are run, then, or, if for any other reason the system starts to run down, a small burner 7, operating on liquid or gaseous fuel 6, through line 5 and valve 48, is ignited by spark mechanism 47 and supplies the heat necessary to support and perpetuate the system until atmospheric temperature and condensing temperature permits the system to operate normally. Fired clay heat retainers 46 are arranged on the grate within burner 7, to retain heat.

The cryogenic system is charged by filling with liquid under pressure through fill pipe 37. Re-charging, if necessary, is done the same way. Engine 15 turns drive shaft 16, which turns generator 17, producing electrical power (110V or 220V) via electric control system 20 which passes the electricity into three channels:

One: To 12-volt controller 23, to run the electrical parts of the system and keep the batteries charged.

Two: To the house 22, to supply the electricity with which to cook, run appliances, light, heat and cool the home.

Three: All remaining electricity is channelled through utility meter 21 into a local utility company's electrical line for sale and use elsewhere.

The "Hidro" Self-Powered Generator of James Kwok.

A quite different style of generator has been built, tested, patented and at this time is available commercially for a limited number of large-scale-use purchasers. This design demonstrates yet again, the practical nature of drawing large quantities of energy from the local environment. Commercial versions are offered in three standard sizes: 50 kilowatt, 250 kilowatt and 1 megawatt and licensing partners are being sought.

The generator which James has designed can be seen at the Panacea-bocaf.org web site at <http://panacea-bocaf.org/hidrofreesystem.htm> and on James' own web site at <http://www.hidroonline.com/> both of which have video clips explaining how the design works. The method is based on different pressures at different depths of water, gravity, and on the buoyancy of air-filled

containers. The design calls for a water-filled structure of some height, a source of compressed air and a pulley system.

The system does not rely on wind, weather, sunlight, fuel of any type, and it can operate all the time, day or night, without causing any kind of pollution or hazard. If I understand it correctly, the overall system looks something like this:

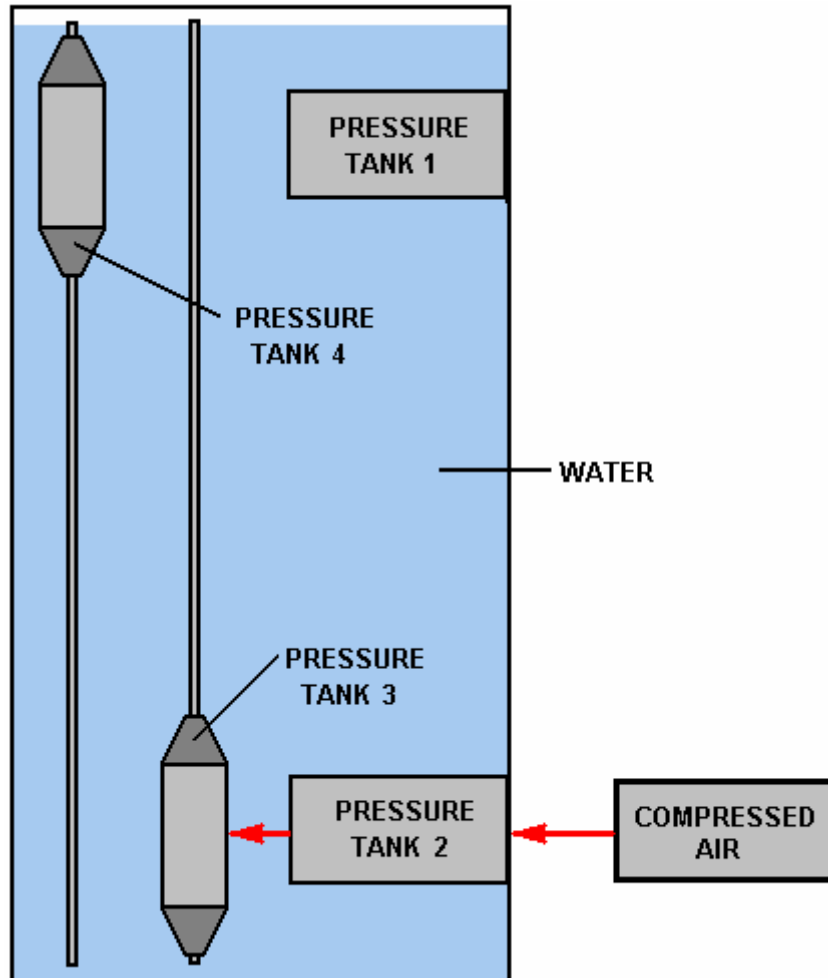

There is a tall, vertical container filled with water. It contains four high-pressure tanks; tanks 1 and 2 are fixed in position while tanks 3 and 4 are mounted on a guidance system which allows them to move up and down vertically, with their movement driving the output generator.

The system is started when an external source of compressed air feeds some into tank 2, where the raised pressure passes compressed air into tank 3, raising its buoyancy and so causing an upward force. The air supply is cut off and tanks 3 and 4 are released.

As tank 3 is highly buoyant, it rises rapidly to the surface, providing output power. Tank 4 has low air pressure in it and so its weight causes it to sink rapidly, also providing output power. When tanks 3 and 4 reach the end of their movements, a system of pipes, latches and valves connect tank 4 to pressure tank 2 and tank 3 to pressure tank 1.

Because tank 3 has now risen to a much lesser depth of water, the outside pressure on it has reduced very considerably. Its internal pressure is now greater than the pressure inside tank 1, so when they are connected by a pipe, air flows out of tank 3 and into tank 1, solely due to the pressure difference between them. This leaves tank 3 no longer in a buoyant state and so when it is released again, it sinks downwards under gravity.

The two moving tanks swap their movements repeatedly, both being re-pressurised by the compressed air supply at the bottom of the structure. If, unlike James, you have not done the mathematics for the system, you would assume that the amount of power generated by a system like this would be less than the amount of power needed to make it operate. However, that is definitely very far from reality as considerable excess power is gained through the natural forces of the local environment which make the system operate.

Patrick Kelly

<http://www.free-energy-info.co.uk>

<http://www.free-energy-info.com>

<http://www.free-energy-devices.com>

engpjk@free-energy-info.co.uk

engpjk@gmail.com