

HELMETS SAVE LIVES !!!

**ALWAYS WEAR A PROPERLY FITTED
HELMET WHEN YOU RIDE YOUR BICYCLE.
DO NOT RIDE AT NIGHT. AVOID RIDING
IN WET CONDITIONS.**



CORRECT FITTING

Make sure your helmet covers your forehead



INCORRECT FITTING

Forehead is exposed and vulnerable to serious injury

Congratulations on your new purchase!

Our Service Department is dedicated to your satisfaction with Cycling Sports Group and its products. For questions regarding performance, assembly, operation, parts or returns, contact the experts at Cycling Sports Group directly by calling toll free

1-800-THE-BIKE

dealerservice-gsm@cyclingsportsgroup.com

The following manual is only a guide to assist you and is not a complete or comprehensive manual of all aspects of maintaining and repairing your bicycle. The bicycle you have purchased is a complex object. We recommend that you consult a bicycle specialist if you have doubts or concerns as to your experience or ability to properly assemble, repair, or maintain your bicycle. You will save time and the inconvenience of having to go back to the store if you choose to write or call us concerning missing parts, service questions, operating advice, and/or assembly questions.



CYCLING SPORTS GROUP™

16 Trowbridge Drive
Bethel, CT 06801 USA
www.schwinnbikes.com

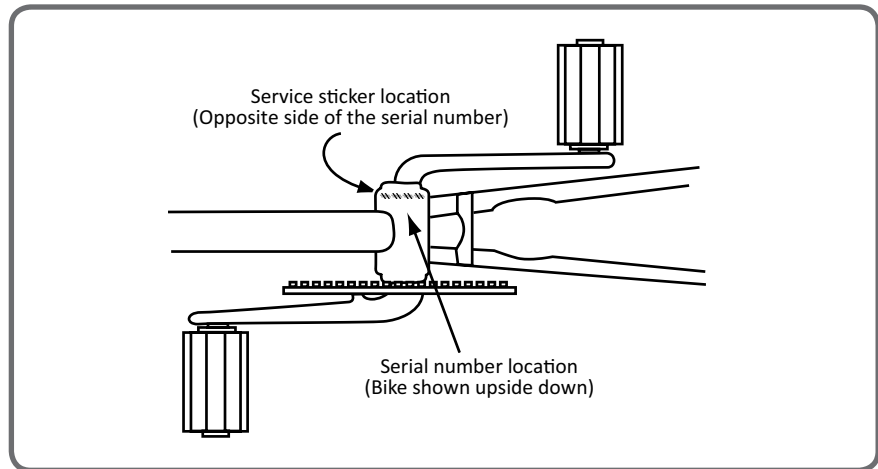

ABOUT THIS MANUAL

It is important for you to understand your new bicycle. By reading this manual before you go out on your first ride, you'll know how to get better performance, comfort, and enjoyment from your new bicycle. It is also important that your first ride on your new bicycle is taken in a controlled environment, away from cars, obstacles, and other cyclists.

GENERAL WARNING

Bicycling can be a hazardous activity even under the best of circumstances. Proper maintenance of your bicycle is your responsibility as it helps reduce the risk of injury. This manual contains many "Warnings" and "Cautions" concerning the consequences of failure to maintain or inspect your bicycle. Many of the warnings and cautions say "you may lose control and fall." Because any fall can result in serious injury or even death, we do not repeat the warning of possible injury or death whenever the risk of falling is mentioned.

A SPECIAL NOTE FOR PARENTS

It is a tragic fact that most bicycle accidents involve children. As a parent or guardian, you bear the responsibility for the activities and safety of your minor child. Among these responsibilities are to make sure that the bicycle which your child is riding is properly fitted to the child; that it is in good repair and safe operating condition; that you and your child have learned, understand and obey not only the applicable local motor vehicle, bicycle, and traffic laws, but also the common sense rules of safe and responsible bicycling. As a parent, you should read this manual before letting your child ride the bicycle. Please make sure that your child always wears an approved bicycle helmet when riding.

1 PARTS IDENTIFICATION6-7

Single Speed Bicycle • Multi Speed Bicycle

2 BEFORE YOU RIDE8-25

Warning, Note to parents • Fit • Helmets, Protective Gear & Clothing • Safety Checklist • Riding Safety • Operation • Security • Maintenance • Storage

3 ASSEMBLY26-49

Tools • Handlebar • Front Wheel • Saddle • Pedals • Adjustments • Final Check

4 MAINTENANCE50-65

Scheduled • Inspection • How to fix a flat tire • Troubleshooting

5 WARRANTY66-67



Take notice of this symbol throughout this manual and pay particular attention to the instructions blocked off and preceded by this symbol.

SINGLE SPEED BICYCLE

Get to know the parts of your bicycle. This will help with assembly, maintenance, and troubleshooting. Single speed bicycles vary greatly. Your model may have additional accessories such as fenders, bags, carriers, etc. Note that smaller children's bicycles also contain training wheels.

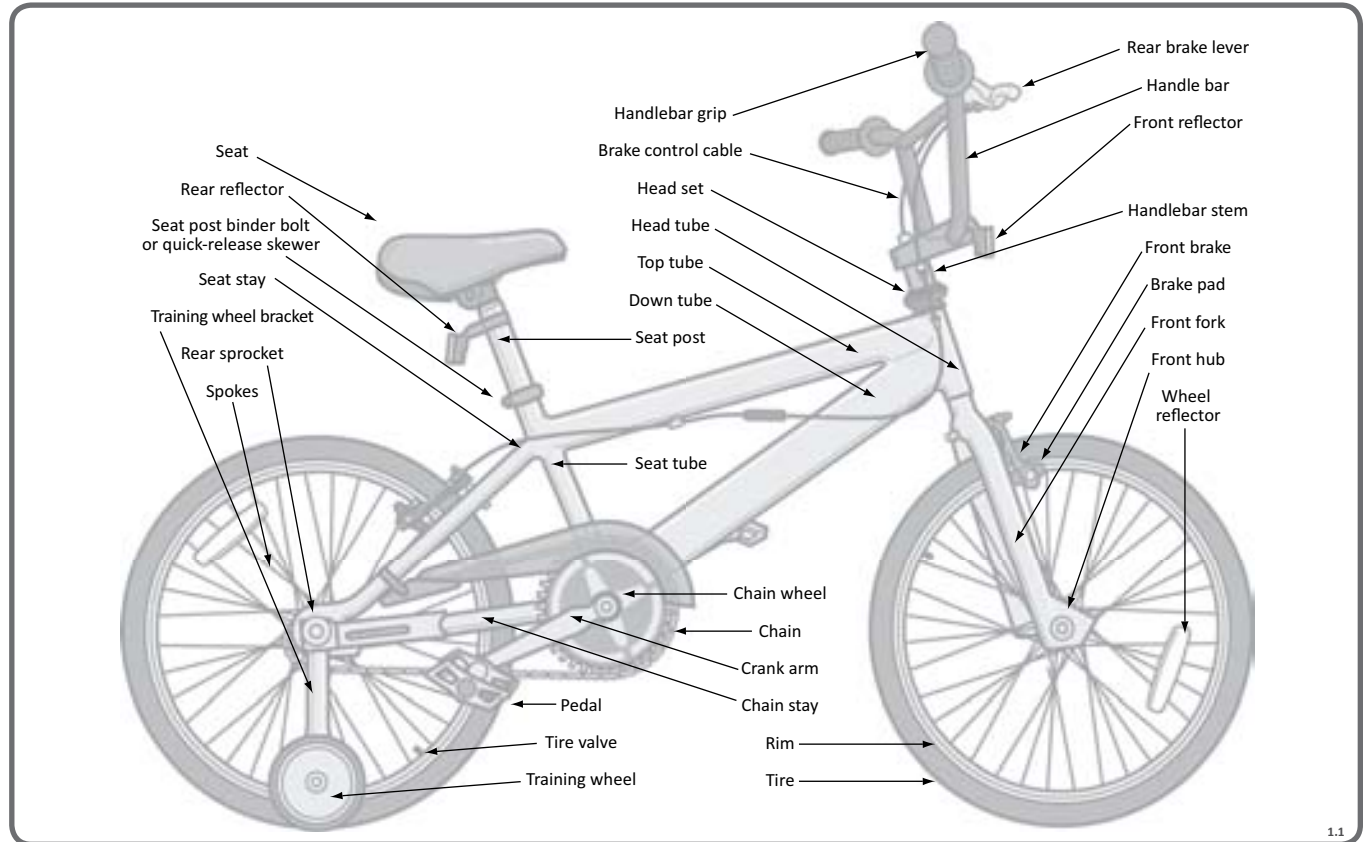

MULTI SPEED BICYCLE

Get to know the parts of your bicycle. This will help with assembly, maintenance, and troubleshooting. Multi speed bicycles vary greatly. Your model may have additional accessories such as fenders, bags, carriers, etc.

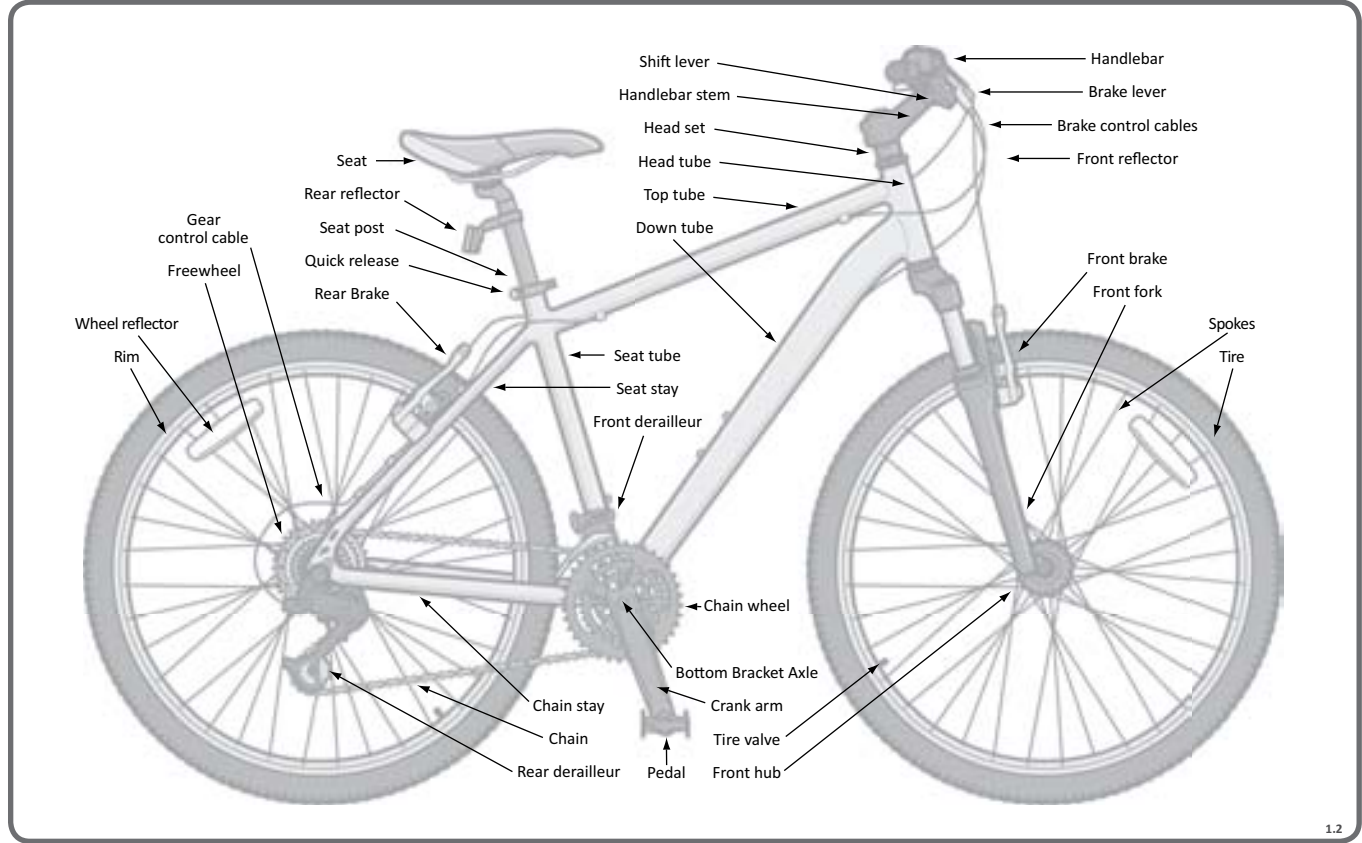

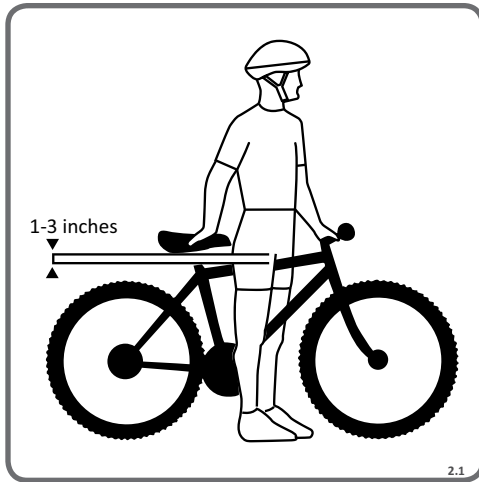

SIZING GUIDE & CHART

When choosing the correct size bicycle, there are some guidelines that will help you determine the correct fit. It is important that you are able to safely mount and dismount the bicycle, and that while riding you are comfortable and can operate the brakes, steering and pedal without any added difficulty.



The first rule is when standing over the bicycle, in front of the seat, straddling the top tube of the bicycle, you should have a minimum of 1-3 inches of clearance.

For ladies frames, pretend there is a top tube, because although you may be able to straddle the frame, you must also be able to reach the handlebars. Bicycles get longer as well as taller as you go up in size.

Wheel size is a good starting point, but bicycles vary, so only use wheel size to get started, after that, check that the rider can safely reach the handlebars while still bending the elbows at least 10 degrees. The saddle height is adjustable, so there is a range of riders that will fit each bicycle. Note that the correct height for the saddle is not determined by foot – to – floor, but by foot – to – pedal. The leg should be almost completely straight when the pedal is in the down most position. Just a slight bend in the knee. This may put the rider in a position where their feet can not touch the ground easily. The rider can simply move forward of the saddle while mounting and dismounting the bicycle. The saddle can be adjusted lower if the rider is uncomfortable this high, but note that riding is more difficult with the saddle too low, as the legs are in an unnatural position. It is common for younger riders who want to feel secure to be able to touch the ground easily, or any rider who is not comfortable with not being able to touch the ground. In this case start off with the saddle lower, and raise the seat as confidence in riding is gained. Do not raise the seat so much that the knees lock straight when pedaling or you have to move forward of the saddle to pedal. This is unsafe and the bicycle can not be controlled in this condition.

Make sure that while riding you can see ahead of you clearly, steer and brake with no difficulty reaching the brake levers or operating foot brakes. Also be sure you can mount and dismount the bicycle quickly if the need arises.

Please refer to the separate adjustment areas of this manual for seat and handlebar adjustments (p. 26 and p. 30)

*Note that some bicycles such as folding bicycles may have smaller wheels but still fit adults.

Bike Wheel Size	Your Approx. Height
12 inch wheel	28 - 38 inches tall
16 inch wheel	38 - 48 inches tall
18 inch wheel	42 - 52 inches tall
20 inch wheel	48 - 60 inches tall
24 inch wheel	56 - 66 inches tall
26 inch wheel	64 - 74 inches tall
700c	64 - 74 inches tall

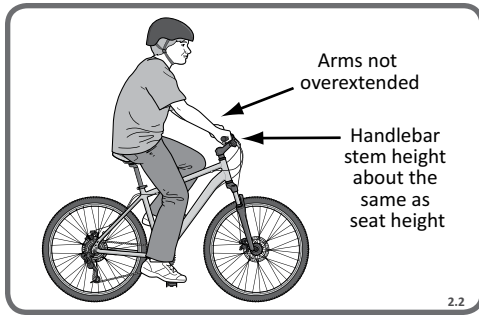

RIDING POSITION

Saddle Height

In order to obtain the most comfortable riding position and offer the best possible pedaling efficiency, the seat height should be set correctly in relation to the rider's leg length. The correct saddle height should not cause leg strain from over-extension, and the hips should not rock from side to side when pedaling. While sitting on the bicycle with one pedal at its lowest point, place the ball of your foot on that pedal. The correct saddle height will allow the knee to be slightly bent in this position. If the rider then places the heel of that foot on the pedal, the leg should be almost straight. (Fig. 2.2)



Under no circumstances should the seat post extend from the frame beyond its "Minimum Insertion" or "Maximum Extension" mark. If your seat post extends from the frame beyond these markings, the seat post or frame may break, which could cause you to lose control and fall. Prior to your first ride, be sure to tighten the saddle adjusting mechanism properly. A loose saddle clamp or seat post binder can cause damage to the bicycle or can cause you to lose control and fall. Periodically check to make sure that the saddle adjusting mechanism is properly tightened.

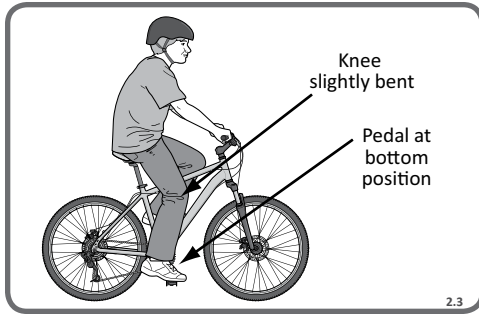

Reach

To obtain maximum comfort, the rider should not overextend his or her reach when riding. To adjust this distance, the position of the seat can be altered in relation to the seat post. (Refer to p.30 on how to adjust the seat clamp.) (Fig. 2.3, 2.4)

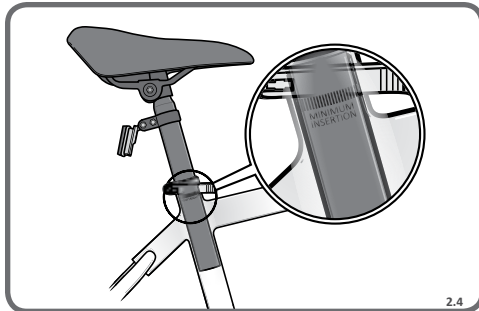

ASTM F2043



1

Suitable for
road riding
(only)**ASTM CONDITION 1²**

"This is a set of conditions for the operation of a bicycle on a regular paved or smooth surface where tires may unintentionally lose ground contact."

INTENDED¹

To be ridden on paved roads only.

NOT INTENDED¹

For off-road, cyclocross, or touring with racks or panniers.

MAXIMUM WEIGHT LIMIT^{1, 3}

RIDER (lbs/kg)	LUGGAGE (lbs/kg)	TOTAL (lbs/kg)
275/125	10/4.5*	285/126

ASTM CONDITION 1²**ROAD TANDEM**

"This is a set of conditions for the operation of a bicycle on a regular paved or smooth surface where tires may unintentionally lose ground contact."

INTENDED¹

Road tandems are designed to be ridden on paved roads only. They are not designed for mountain biking or off-road use. Road tandems are designed for touring with racks and panniers.

NOT INTENDED¹

Road tandem should not be taken off-road or used as a mountain tandem.

MAXIMUM WEIGHT LIMIT^{1, 3}

RIDER (lbs/kg)	LUGGAGE (lbs/kg)	TOTAL (lbs/kg)
500 / 227	75 / 34	575 / 261

CHILD BIKE

These bikes are designed for children riding where parental supervision is always required. Riders shall avoid areas used by automobiles, as well as inclines, curves, stairs, or areas near drop-offs or pools.

- Maximum seat height of 68mm; generally, bicycles with 16" or 20" wheels, and kids' tricycles
- No quick-release wheel fastening systems
- Weight limit: 80 lbs (36 kg)

ASTM F2043



2

For off-road riding and jumps less than 12" (30cm)

ASTM CONDITION 2²

INTENDED¹

"This is a set of conditions for the operation of a bicycle that includes Condition 1 as well as unpaved and gravel roads and trails with moderate grades. Contact with irregular terrain and loss of tire contact with the ground may occur. Jumps should be limited to 30cm (12in.) or less."

For paved roads, gravel or dirt roads that are in good condition, and bike paths.

NOT INTENDED¹

For off-road or mountain bike use, or for any kind of jumping. Some of these bikes have suspension features, but these features are designed to add comfort, not off-road capability. Some come with relatively wide tires that are well suited to gravel or dirt paths. Some come with relatively narrow tires that are best suited to faster riding on pavement. If you ride on gravel or dirt paths, carry heavier loads or want more tire durability talk to your dealer about wider tires.

MAXIMUM WEIGHT LIMIT^{1, 3}

RIDER (lbs/kg)	LUGGAGE (lbs/kg)	TOTAL (lbs/kg)
500 / 227	75 / 34	575 / 261

ASTM F2043

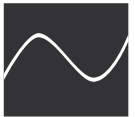

3

For rough off-road riding and jumps less than 24" (61 cm)

ASTM CONDITION 3²

INTENDED¹

"This is a set of conditions for the operation of a bicycle that includes Condition 1 and Condition 2 as well as rough trails, rough un-paved roads, and rough technical areas and unimproved trails. Jumps of 60 cm (24 in.) or less are anticipated"

For cross-country riding and racing which ranges from mild to aggressive over intermediate terrain (e.g., hilly with small obstacles like roots, rocks, loose surfaces and hard pack and depressions). There are no large "sick drop" or drop offs, jumps or launches (wooden structures, dirt embankments) requiring long suspension travel or heavy duty components. Cross-country and marathon equipment (tires, shocks, frames, drive trains) are light-weight, favoring nimble speed over brute force. Suspension travel is relatively short since the bike is intended to move quickly on the ground and not spend time in the air landing hard and hammering through things.

NOT INTENDED¹

For use in extreme forms of jumping/riding such as hardcore mountain, Freeriding, Downhill, North Shore, Dirt Jumping, Hucking etc.

MAXIMUM WEIGHT LIMIT^{1, 3}

RIDER (lbs/kg)	LUGGAGE (lbs/kg)	TOTAL (lbs/kg)
300 / 136	5 / 2.3*	305 / 138

2

BEFORE YOU RIDE

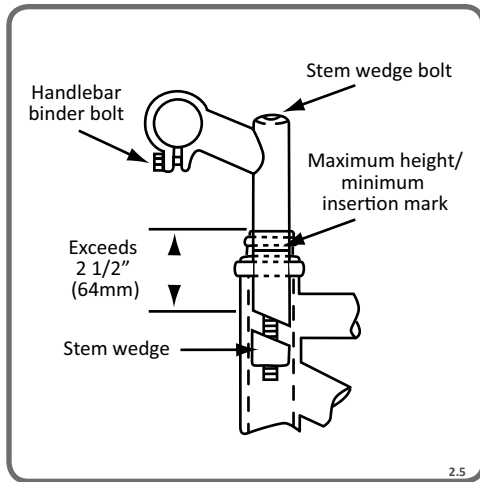

Handlebar Height

Maximum comfort is usually obtained when the handlebar height is equal to the height of the seat. You may wish to try different heights to find the most comfortable position.



Threadless headsets and clamp-on stems are not adjustable. Please refer to assembly-adjustments (p. 27) for instructions on installation.

The stem's "Minimum Insertion" mark must not be visible above the top of the headset. If the stem is extended beyond this mark, the stem may break or damage the fork's steer tube, which could cause you to lose control and fall.

Failure to properly tighten the stem binder bolt, the handlebar binder bolt, or the bar end extension clamping bolts may compromise steering action, which could cause you to lose control and fall. Place the front wheel of the bicycle between your legs and attempt to twist the handlebar/stem assembly using a reasonable amount of force. If you can twist the stem in relation to the front wheel, turn the handlebars in relation to the stem, or turn the bar end extensions in relation to the handlebar, you must tighten the appropriate bolts accordingly.

2.5

HELMETS, PROTECTIVE GEAR & CLOTHING

Helmets



A WORD TO PARENTS REGARDING CHILDREN AND HELMETS: Many states have passed helmet laws regarding children. Make sure you know your states helmet laws. It is your job to enforce these rules with your children. Even if your state does not have a children’s helmet law, it is recommended that everyone wear a helmet when cycling. When riding with a child carrier seat or trailer, children must wear a helmet.

It is strongly advised that a properly fitting, ASTM or SNELL approved, bicycle safety helmet be worn at all times when riding your bicycle. In addition, if you are carrying a passenger in a child safety seat, they must also be wearing a helmet.

The correct helmet should:

- be comfortable
- have good ventilation
- fit correctly
- cover forehead



Always wear a properly fitted helmet which covers the forehead when riding a bicycle. Many states require specific safety devices. It is your responsibility to familiarize yourself with the laws of the state where you ride and to comply with all applicable laws, including properly equipping yourself and your bike as the law requires. Reflectors are important safety devices which are designed as an integral part of your bicycle. Federal regulations require every bicycle (over 16”) to be equipped with front, rear, wheel, and pedal reflectors. These reflectors are designed to pick up and reflect street lights and car lights in a way that helps you to be seen and recognized as a moving bicyclist. Check reflectors and their mounting brackets regularly to make sure they are clean, straight, unbroken and securely mounted.



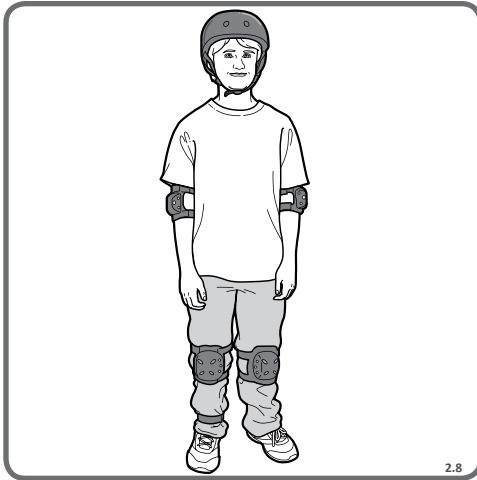

Choosing Riding Clothing and Protective Gear

When choosing to ride a bicycle, the riders should always consider the clothing they will wear. Any loose clothing parts or strings can get caught in a bicycle's moving parts and cause an accident. Be sure there are no loose cords, strings, over-sized cuffs or pant legs. Loose pants should be tied or tucked into a sock. A leg band is often used to keep pants from getting caught in the chain of the bicycle. Be sure shoelaces are tied tightly, and do not hang out. (Fig. 2.8)

Dress for the weather keeping in mind that when cycling, the wind can be colder than just walking or standing. Reflective clothing is always recommended for cycling. Avoid wearing all black, or dark clothes. A brightly colored jacket or shirt is a great way to help motorists and others see you.

Choosing to wear protective gear is the rider's or parent's responsibility and is highly recommended. Protective gear is available to cover knees and elbows, backs and shoulders and more.



Use of protective gear can greatly reduce injuries while riding. If protective gear is worn, be sure that it does not interfere with steering, braking and pedaling. Know your own abilities, and do not ride beyond them. (Fig. 2.9)



SAFETY CHECKLIST

Before every ride, it is important to carry out the following safety checks:

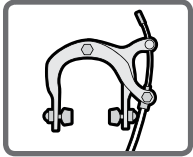

Brakes

- Ensure front and rear brakes work properly.
- Ensure brake shoe pads are not overly worn and are correctly positioned in relation to the rims.
- Ensure brake control cables are lubricated, correctly adjusted and display no obvious wear.
- Ensure brake control levers are lubricated and tightly secured to the handlebar.

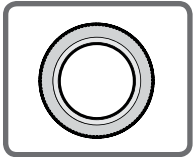

Wheels and Tires

- Ensure tires are inflated to within the recommended pressure as displayed on the tire sidewall.
- Ensure tires have tread and have no bulges or excessive wear.
- Ensure rims run true and have no obvious wobbles or kinks.
- Ensure all wheel spokes are tight and not broken.
- Check that axle nuts are tight. If your bicycle is fitted with quick release axles, make sure locking levers are correctly tensioned and in the fully closed position.

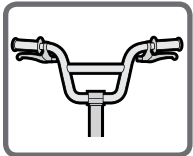

Steering

- Ensure handlebar and stem are correctly adjusted and tightened, and allow proper steering.
- Ensure that the handlebars are set correctly in relation to the forks and the direction of travel.
- Check that the headset locking mechanism is properly adjusted and tightened.
- If the bicycle is fitted with handlebar end extensions, ensure they are properly positioned and tightened.

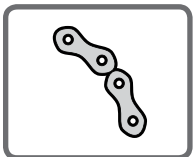

Chain

- Ensure chain is oiled, clean and runs smoothly.
- Extra maintenance is required in wet or dusty conditions.

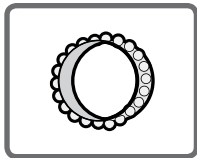

Bearings

- Ensure all bearings are lubricated, run freely and display no excess movement, grinding or rattling.
- Check headset, wheel bearings, pedal bearings and bottom bracket bearings.

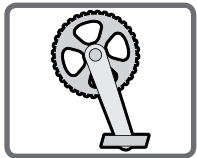

Cranks and Pedals

- Ensure pedals are securely tightened to the cranks.
- Ensure cranks are securely tightened to the axle and are not bent.

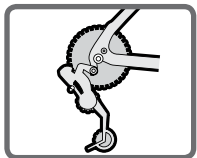

Derailleurs

- Check that front and rear derailleurs are adjusted and function properly.
- Ensure shift levers are securely attached.
- Ensure derailleurs, shift levers and control cables are properly lubricated.

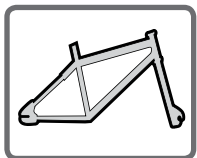

Frame and Fork

- Check that the frame and fork are not bent or broken.
- If either are bent or broken, they should be replaced.

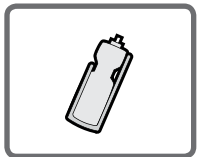

Accessories

- Ensure that all reflectors are properly fitted and not obscured.
- Ensure all other fittings on the bike are properly and securely fastened, and functioning.
- Ensure the rider is wearing a properly fitted helmet.

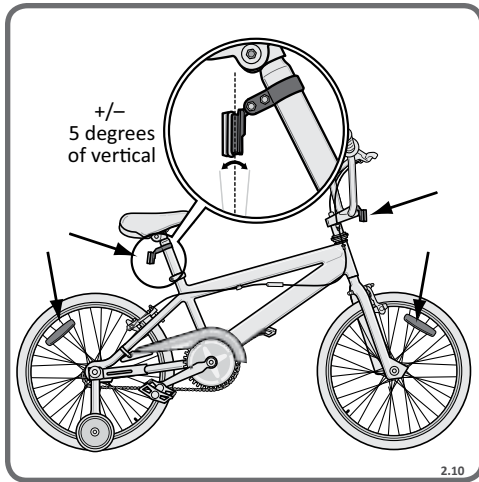

Reflectors

16" and under bicycles are considered "sidewalk bicycles", and may not be fitted with reflectors. These bicycles should not be ridden on streets, at night or unattended by an adult. All other bicycles are supplied with one front (white), one rear (red), two wheel (white), and four pedal (orange) reflectors. These are an important safety and legal requirement, and should remain securely fitted and in good, clean condition at all times. Periodically, inspect all reflectors, brackets and mounting hardware for signs of wear or damage. Replace immediately if damage is found. Front & rear reflectors should be mounted so that they are within 5 degrees of vertical (when looking at them from the side of the bike, while the bike is on level ground). The front reflector should aim forward (when viewed from above), and the rear reflector should aim straight back (when viewed from above). Wheel reflectors should be checked to be sure they are tight, and should be kept clean.

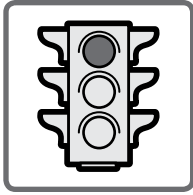

RIDING SAFETY

General Rules

- When riding obey the same road laws as all other road vehicles, including giving way to pedestrians, and stopping at red lights and stop signs. For further information, contact the Road Traffic Authority in your State.
- Ride predictably and in a straight line. Never ride against traffic.
- Use correct hand signals to indicate turning or stopping.
- Ride defensively. To other road users, you may be hard to see.
- Concentrate on the path ahead. Avoid pot holes, gravel, wet road markings, oil, curbs, speed bumps, drain grates and other obstacles.
- Cross train tracks at a 90 degree angle or walk your bicycle across.
- Expect the unexpected such as opening car doors or cars backing out of concealed driveways.
- Be extra careful at intersections and when preparing to pass other vehicles.
- Familiarize yourself with all the bicycle's features. Practice gear shifts, braking, and the use of toe clips and straps, if installed.
- If you are wearing loose pants, use leg clips or elastic bands to prevent them from being caught in the chain.
- Wear proper riding attire and avoid open toe shoes.
- Don't carry packages or passengers that will interfere with your visibility or control of the bicycle.
- Don't use items that may restrict your hearing.
- Do not lock up the brakes. When braking, always apply the rear brake first, then the front. The front brake is more powerful and if it is not correctly applied, you may lose control and fall.
- Maintain a comfortable stopping distance from all other riders, vehicles and objects.
- Safe braking distances and forces are subject to the prevailing weather conditions.

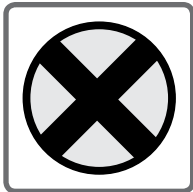



Wet Weather

- In wet weather you need to take extra care.
- Brake earlier, you will take a longer distance to stop.
- Decrease your riding speed, avoid sudden braking and take corners with additional caution.
- Be more visible on the road.
- Wear reflective clothing and use safety lights.
- Pot holes and slippery surfaces such as line markings and train tracks all become more hazardous when wet.



Night Riding



IT IS RECOMMENDED TO NOT RIDE AT NIGHT

Check your local laws regarding night riding;
Many areas require the use of lights for night riding in addition to a full set of CPSC compatible reflectors.

- Ensure bicycle is equipped with a full set of correctly positioned and clean reflectors.
- Refer to p. 15 of this manual.
- Use a properly functioning lighting set comprising of a white front lamp and a red rear lamp.
- If using battery powered lights, make sure batteries are well charged.
- Some rear lights available have a flashing mechanism which enhances visibility.
- Wear reflective and light colored clothing.
- Ride at night only if necessary. Slow down and use familiar roads with street lighting, if possible.





Rules for Children

To avoid accidents, teach children good riding skills with an emphasis on safety from an early age. Children should be supervised by an adult.

1. Many states require that children wear a helmet while cycling. Always wear a properly fitted helmet.
2. Do not play in driveways or the road.
3. Do not ride on busy streets.
4. Do not ride at night.
5. Obey all the traffic laws, especially stop signs and red lights.
6. Be aware of other road vehicles behind and nearby.
7. Before entering a street: Stop, look left, right, and left again for traffic. If there's no traffic, proceed into the roadway.
8. If riding downhill, be extra careful. Slow down using the brakes and maintain control of the steering.
9. Never take your hands off the handlebars, or your feet off the pedals when riding downhill.

The Consumer Protection Safety Commission advises that the riding of small wheel diameter bicycles at excessive speeds can lead to instability and is not recommended.

Children should be made aware of all possible riding hazards and correct riding behavior before they take to the streets. Do not leave it up to trial and error.



BRAKE OPERATION

There are 2 types of braking systems for bicycles; Foot operated and hand operated.

Foot Operated Brakes

Foot operated brakes allow the rider to pedal forward to accelerate the bicycle, and pedal backwards to brake. The harder you push back on the pedals, the more braking force is applied to the rear wheel. In most cases a foot operated brake is strong enough to “lock up” (stop the wheel from turning) the rear wheel and cause the tire to skid. While this will decelerate the bicycle quickly, it will also cause unnecessary wear on the tire, and terrain, and can cause a loss of steering control. It is recommended to practice braking so that you have control over how quickly the bicycle comes to a stop. It is also important to know the environment that you are riding on. For example, a dry paved road is very predictable when stopping. But if you add rain, gravel, snow or any thing else, the rider needs to be extra careful, and allow extra stopping distance, and slow down before turning. The rider should also be careful as terrain changes to keep the bicycle at a controllable speed.

Some models may have a combination of foot and hand operated brakes. It is OK to operate them at the same time or independently. However, if the bicycle is equipped with a front wheel hand brake, be careful to use front and rear brake simultaneously, and avoid locking up the front wheel, as this can cause a loss of steering control, and cause a crash. See hand operated brakes (p. 20) for more detail.



Hand Operated Brakes

Hand operated brakes have a separate hand lever to operate front and rear brakes. Front hand brake levers are located on the left side of the handlebar, and rear hand brake levers are located on the right side of the handlebar. Hand operated brakes may be used alone or on some models in conjunction with foot operated brakes. It is OK to operate one brake at a time, or all together, depending on your style, comfort, and riding conditions, however, be careful to pay close attention to front brakes locking up;



If the front brake is applied too quickly or too hard, the front wheel can stop turning resulting in a front pitch over or cause the bicycle to lose steering function leading to a crash.

To best avoid this, apply the front and rear brakes simultaneously, while shifting your body weight back slightly to compensate for braking force. As terrain changes, the rider must practice and learn how each bicycle will respond in a new terrain or weather change. The same bicycle will react differently if it is wet, or if there is gravel on the road etc. Always test the brakes and be sure you feel comfortable with the reaction. If the riding conditions are too steep (off road for example) and you are unsure, dismount the bicycle and walk past the questionable terrain before riding again. Remember that as you apply the brakes your weight will want to shift forward, and the wheels will want to stop. See Assembly and Maintenance for further information on brake adjustment. (Fig. 2.12)

GEAR OPERATION

Multi speed bicycles can have internal or derailleur gear systems.

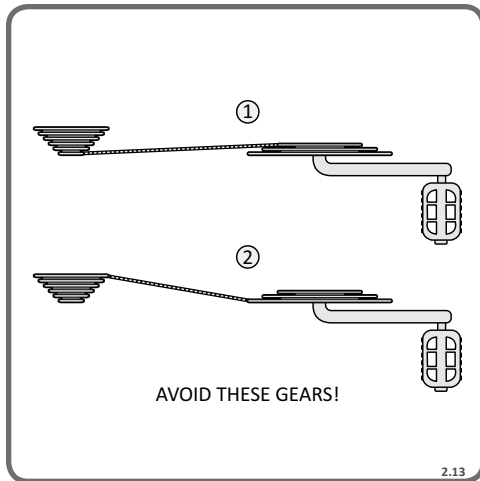

WARNING: Improper shifting can result in the chain jamming, or becoming derailed resulting in loss of control or a crash.



Always be sure the chain is fully engaged in the desired gear before pedaling hard.



Avoid shifting while standing up on the pedals or under load.



To shift properly, pedal the bicycle with little pressure on the pedals, and move the shifter (1) gear at a time, ensuring that the chain is fully engaged in that gear before applying more pressure on the pedals. For bicycles with 3 front chain rings; avoid “Cross Chaining”, which is the position when the chain is in the smallest cog in the rear combined with the inner or smallest chain ring in the front, or the largest cog in the rear and the outer or largest chain ring in the front. These gear positions put the chain at the most extreme angle and can cause premature wear to the drivetrain. Bicycles with 3 front chain rings have enough gear “overlaps” that these gears are not needed. (Fig. 2.13)

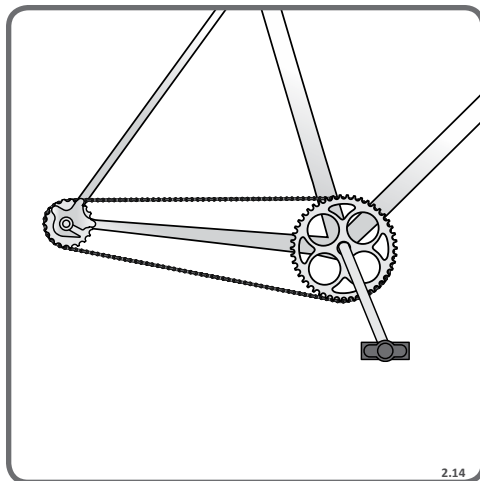

Internal Gears (no derailleur)

An internal gear system is one where the gears are housed within the rear hub of the bicycle. With internally geared bicycles, it is recommended to STOP pedaling while you shift gears. The bike may be sitting still or rolling to shift. Shifter designs vary, you will either twist or operate a push button to change gears. The shifter will indicate either “low” to “high” or a series of numbers from 1 up. Low or “1” is the lowest gear. This is used for slower riding, hill climbing, or to allow for easier pedaling. It is recommended to start off in this gear and move through the gears as speed increases as needed, or comfortable. It is OK to ride the whole time in only one gear if this is comfortable. Backpedaling should have no effect on an internally geared bicycle (unless it is equipped with foot activated brakes), however, backpedaling should not be necessary when riding, and invites the possibility of clothing being caught in the chain, and should be avoided. See Assembly and Maintenance for further information on proper gear adjustment. (Fig. 2.14)

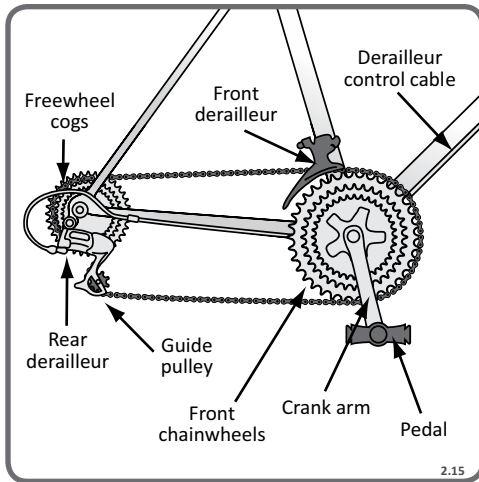

External Gears (derailleur equipped bicycles)

Derailleur equipped bicycles all have a rear derailleur. Some may also have a front derailleur offering more gear choices. The right side shifter will operate the rear derailleur, and the left side (if equipped) will operate the front derailleur. On derailleur equipped bicycles, it is important to be pedaling forward when shifting gears. This allows the chain to “derail” from one gear to the next. Operating the shifter while sitting still or not pedaling can cause damage to the system, and can be dangerous, as the chain may jam and cause the bike to become unstable. (Fig. 2.15)

Avoid back pedaling on any bicycle with derailleurs. Backpedaling can derail the chain and cause it to jam or fall off the gears. When shifting gears, make sure you pedal forward until the gear has completely changed. (At least one full rotation of the pedals.) Failure to do so, may result in the chain not engaging properly the next time you pedal forward, or falling off altogether causing a possible danger when you attempt to pedal again. Remember always pedal through the gear change on a derailleur equipped bicycle.

Rear Shifter

The rear shifter (right) will have an indicator that reads either “low to “high” or a series of numbers from 1 up. Low or “1” is the lowest gear. This is used for slower riding, hill climbing, or to allow for easier pedaling. It is recommended to start off in this gear and move through the gears as speed increases as needed, or comfortable. It is OK to ride the whole time in only one gear if this is comfortable. Shift only while pedaling forward and seated. When shifting, lessen the pressure exerted on the pedals during the shift. Once you have successfully shifted gears, it is OK to start to pedal hard if desired. Pedaling hard while shifting can cause the chain to skip and not engage the appropriate gear. Backpedaling should be avoided on derailleur bikes because the chain can jam and cause the bike to become unstable. See Assembly and Maintenance for further information on proper gear adjustment. (Fig. 2.16)

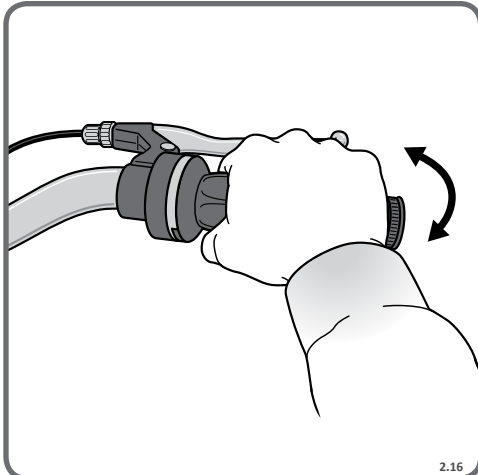

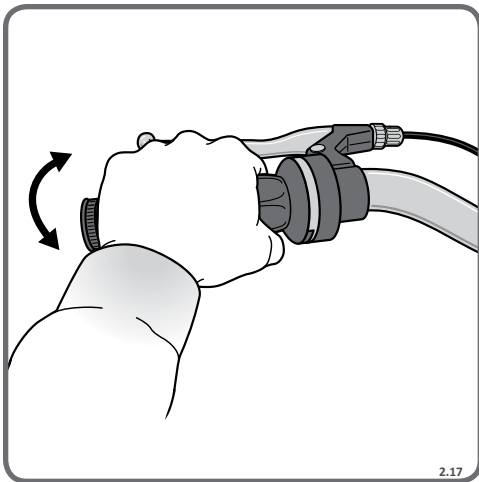

2.17

Front Shifter

Note that not all models have a front shifter. The front (left) shifter will have an indicator that reads either “low to “high” or a series of numbers from 1 up. Low or “1” is the lowest gear. The front shifter acts much like the rear shifter, but the change between gears is greater. This means that one shift at the rear derailleurs will be a subtle change in pedaling speed, but one shift at the front derailleurs will be a large change in pedaling speed. Think of the front shifter as a “range”, low and high or low, medium, and high. Low is used for slower riding, hill climbing, or to allow for easier pedaling. It is recommended to start off in this gear and move through the gears as speed increases as needed, or comfortable. It is OK to ride the whole time in only one gear if this is comfortable. Shift only while pedaling forward. When shifting, lessen the pressure exerted on the pedals during the shift. Once you have successfully shifted gears, it is OK to start to pedal hard if desired. Pedaling hard while shifting can cause the chain to skip and not engage the appropriate gear. Backpedaling should be avoided on derailleurs bikes because the chain can jam and cause the bike to become unstable. (Fig. 2.17)

SECURITY

You just bought a new bicycle! Don’t lose it. It is advisable that the following steps be taken to prepare for and help prevent possible theft:

- Maintain a record of the bicycle’s serial number, generally located on the frame underneath the bottom bracket.
- Register the bicycle with the local police and/or bicycle registry.
- Invest in a high quality bicycle lock that will resist hacksaws and bolt cutters. Always lock your bicycle to an immovable object if it is left unattended. Keep in mind that individual parts of a bicycle may be stolen. Most commonly, if you lock just a wheel or just the frame, other parts may be removed from the bicycle. Although it is impossible to lock all the parts, it is suggested to lock the major components if possible. Use a lock that is long enough to lock the frame and both wheels if possible. Some models with quick release front wheels allow the front wheel to be placed beside the frame so a smaller lock can be used to lock all 3 components. Be aware that a quick release seatpost can be stolen. It is recommended to remove the seatpost and saddle and carry it with you if you believe that this is a risk.

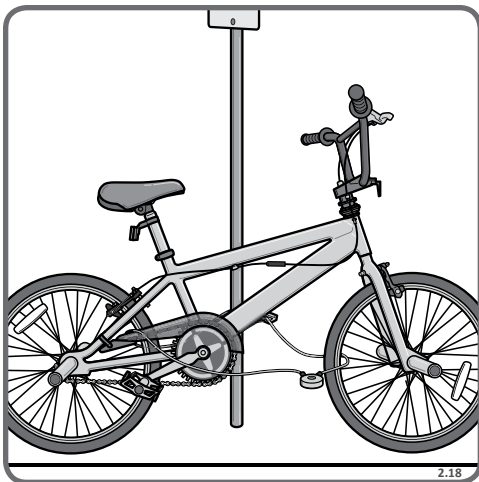

2.18

BASIC MAINTENANCE

The following procedures will help you maintain your bicycle for years of enjoyable riding.

- For painted frames, dust the surface and remove any loose dirt with a dry cloth. To clean, wipe with a damp cloth soaked in a mild detergent mixture. Dry with a cloth and polish with car or furniture wax. Use soap and water to clean plastic parts and rubber tires. Chrome plated bikes should be wiped over with a rust preventative fluid.
- Store your bicycle under shelter. Avoid leaving it in the rain or exposed to corrosive materials.
- Riding on the beach or in coastal areas exposes your bicycle to salt which is very corrosive. Wash your bicycle frequently and wipe or spray all unpainted parts with an anti-rust treatment. Make sure wheel rims are dry so braking performance is not affected. After rain, dry your bicycle and apply anti-rust treatment. If the hub and bottom bracket bearings of your bicycle have been submerged in water, they should be taken out and re-greased. This will prevent accelerated bearing deterioration.
- If paint has become scratched or chipped to the metal, use touch up paint to prevent rust. Clear nail polish can also be used as a preventative measure.
- Regularly clean and lubricate all moving parts, tighten components and make adjustments as required. (Refer to Parts 4 and 5 of this manual for further details).

STORAGE

- Keep your bicycle in a dry location away from the weather and the sun. Ultraviolet rays may cause paint to fade or rubber and plastic parts to crack.
- Before storing your bicycle for a long period of time, clean and lubricate all components and wax the frame.
- Deflate the tires to half pressure and hang the bicycle off the ground.
- Don't store near electric motors as ozone emissions may effect the rubber and paint.
- Don't cover with plastic as "sweating" will result which may cause rusting.
- Please notice that your bicycle warranty does not cover paint damage, rust, corrosion, dry rot or theft.

TOOLS FOR ASSEMBLY

Your new bicycle was assembled and tuned in the factory and then partially disassembled for shipping. You may have purchased the bicycle already fully assembled and ready to ride OR in the shipping carton in the partially disassembled form. The following instructions will enable you to prepare your bicycle for years of enjoyable cycling. For more details on inspection, lubrication, maintenance and adjustment of any area please refer to the relevant sections in this manual. If you have questions about your ability to properly assemble this unit, please consult a qualified specialist before riding. If you need replacement parts or have questions pertaining to the assembly of your bicycle, call the service line direct at:

SERVICE & TECHNICAL SUPPORT

CALL TOLL FREE 1-800-THE-BIKE

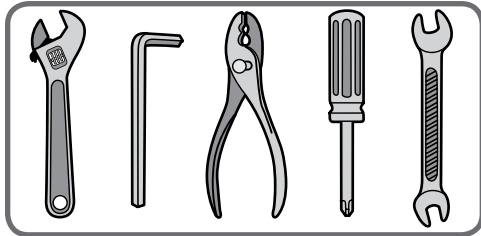

Tools Required:

- Phillips head screw driver
- 4mm, 5mm, 6mm and 8mm Allen keys
- Adjustable wrench or a 9mm, 10mm, 14mm and 15mm open and box end wrenches
- A pair of pliers with cable cutting ability

! To avoid injury, this product must be properly assembled before use. If your bicycle was obtained assembled, we strongly recommend that you review the complete assembly instructions and perform checks specified in this manual before riding.

? We recommend that you consult a bicycle specialist if you have doubts or concerns as to your experience or ability to properly assemble, repair, or maintain your bicycle.

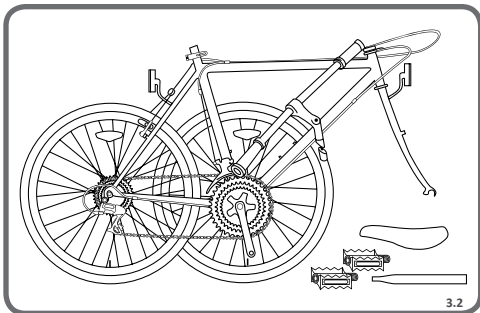

GETTING STARTED

Open the carton from the top and remove the bicycle. Remove the straps and protective wrapping from the bicycle. Inspect the bicycle and all accessories and parts for possible shortages. It is recommended that the threads and all moving parts in the parts package be lubricated prior to installation. Do not discard packing materials until assembly is complete to ensure that no required parts are accidentally discarded. Assemble your bicycle following the steps that pertain to your model. (Fig. 3.2)

NOTE: Your bicycle may be equipped with different style components than the ones illustrated.

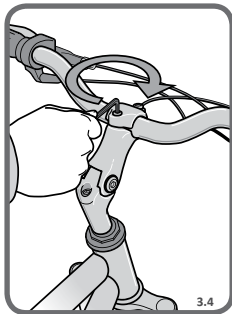
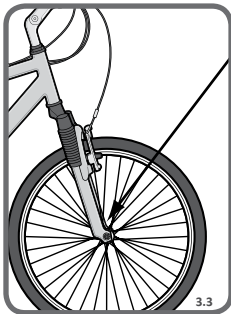

HANDLEBAR ASSEMBLY

Remove all protective packaging from the handlebar assembly if not already done. Turn the fork of the bicycle to face forward. Note that “forward” means that the wheel mounting slots are in the furthest forward position. So the wheel axle will be in front of the fork when assembled. (Fig. 3.3)

Check handlebar stem clamp bolts to be sure they are properly tightened, and handlebar can not move. The angle of the handlebar can be adjusted. To adjust; loosen all of the handlebar stem clamping bolts, and rotate the handlebar to the desired angle. Be sure that the handlebar stays centered in the stem. Retighten the bolts a LITTLE at a time being sure that the gap between the stem cap and stem stays even. Repeat tightening each bolt a little bit until handlebar is secure. (Fig. 3.4)

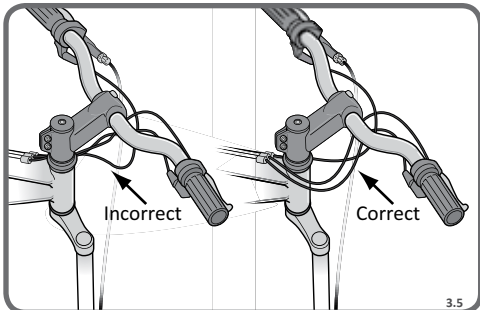

Models with gear and/or brake cables:

Locate the handlebar assembly. If your model bicycle comes equipped with gears and/or handbrakes, you will need to be sure that the brake cables and shift cables are properly routed. Position the handlebar assembly as if you were going to install it, and take a look at the cables. They should run in a smooth arc from the shifter or brake lever to the front brake or cable stop on the frame. If they are twisted or kinked, the shifting and braking will not work. Rotate the handlebars around until the cables are taking the smoothest route. (Fig. 3.5)

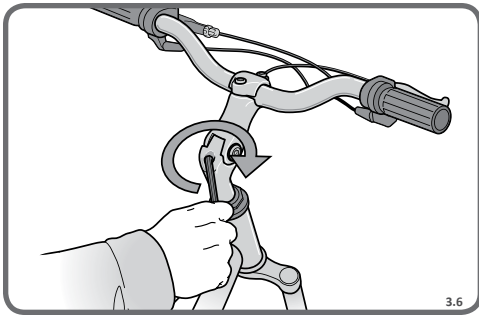

There are 2 basic types of handlebar mounting; Quill and Threadless.

Quill Stems

This is a handlebar assembly that has a wedge shaped part at the bottom of the stem that is inserted into the fork steer tube. Loosen the center bolt enough so that the wedge and stem can slide into the fork steer tube. Lower the stem until the mark that says “minimum insertion” is not visible. Tighten the stem center bolt so that the handlebar assembly is in line with the fork. If needed, you can re-check this after the front wheel is installed, and re-adjust. (Fig. 3.6)

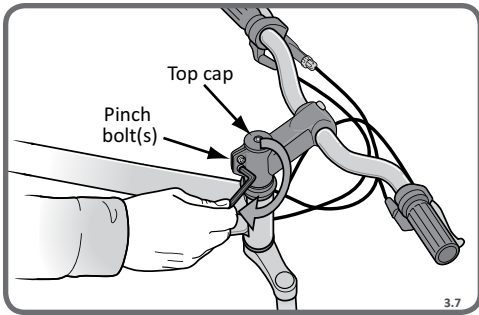

Threadless Stems

This is a handlebar assembly that has a open ended stem with 1 or more pinch bolts that goes outside of the fork steer tube. For this system it is important not to disassemble the headset and lose any parts. Be sure that the end of the fork is on the ground or being held with your free hand, because once you loosen the top cap, the fork assembly may fall out of the frame. Loosen the top cap of the fork steer and remove any cardboard packing, the top cap, and bolt. Set these aside so you can easily retrieve them. While holding the fork assembly in place, slide the handlebar assembly onto the fork tube. Replace the top cap and bolt. Tighten the top cap bolt only until the handlebar assembly and fork have no free play, but so that the handlebar assembly and fork can still freely turn left and right. Then tighten the pinch bolt(s) evenly with the handlebar assembly facing forward. If needed you can re-check this after the front wheel is installed, and re-adjust. (Fig. 3.7)

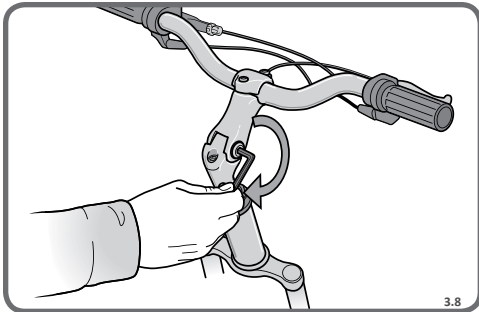

NOTE: Comfort Series bicycles may be equipped with a stem that has an adjustable angle. In addition to the normal assembly, these stems will require angling the stem to the desired position, and securely tightening the angle bolt located in front of the stem bolt. Failure to do this may cause loss of steering control. (Fig. 3.8)



If the stem is not inserted at least the “Minimum Insertion” mark, it is possible to over-tighten the stem bolt and damage the fork steerer tube. If these instructions are not followed, it could cause an unsafe condition and risk injury to the rider. Check steering tightness prior to riding by straddling the front wheel. Try turning the handlebar. If you can turn it without turning the front wheel, the stem is too loose. Re-align the handlebar with the front wheel and re-tighten the stem bolt.

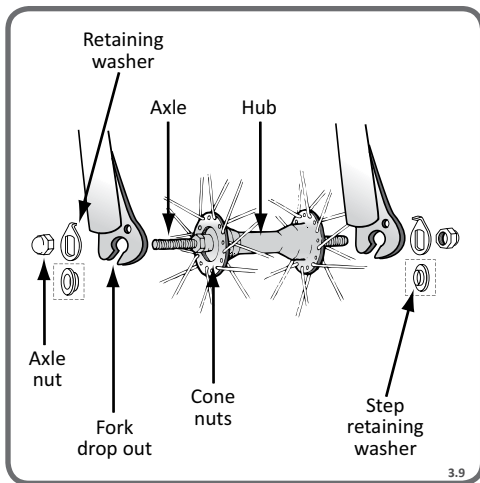

FRONT WHEEL

There are two types of front wheel hubs; Nuted and quick release.

Nuted Front Wheels

Loosen the axle nuts on the front wheel. If there is a washer inside of the axle nut, it belongs outside of the fork dropouts. If the washer has a hook or a step, be sure that it engages the fork before tightening the axle nuts. Slide the front wheel between the fork dropouts. If the wheel has a hook shaped washer, be sure that the hook is hooked into the hole above the wheel slot. If there is a step washer, be sure the step fits into the key hole at the top of the wheel slot. Tighten the two outer axle nuts evenly; Tighten one side part way, then tighten the other side and repeat until both sides are tightened securely. Be sure that the wheel is centered between the fork legs. If it is off center, loosen the axle nut on the side that has a smaller gap between tire and fork leg, and use your hand to push the wheel to a centered position; hold the wheel with one hand, and tighten the axle nut and check again. Repeat if needed to be sure the wheel is centered and securely tightened. (Fig. 3.9)

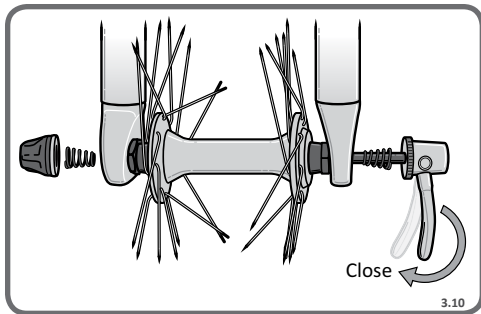

3.10

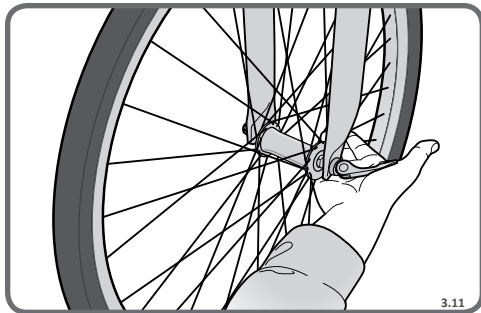

3.11

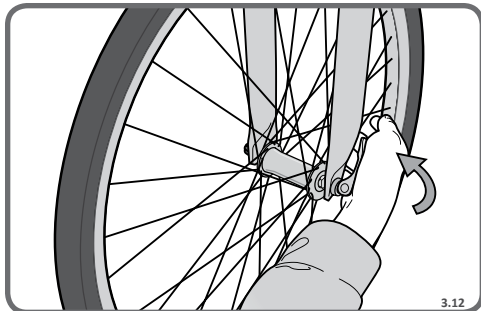

3.12

Quick Release Wheels

1. Locate the quick release skewer from the small parts carton of your bicycle. Some tire tread patterns have a direction, so compare your front tire and rear tire of the bicycle so that both tread patterns face the same way. (Fig. 3.10)
2. Unscrew the lock nut from the quick release skewer, remove outer spring and slide the skewer through the front wheel axle so that the handle is on the left side of the bike (the side opposite the chain). (Fig. 3.11)
3. Install spring and then start to thread the lock nut back onto the skewer, but do not tighten too far.
4. Slide the wheel into the fork wheel slots and be sure that the wheel is centered.
5. Inspect the handle, note that there's an "open" and a "closed" position. Move the handle so it is in the "open" position. With one hand on the handle and one hand on the lock nut, start to hand tighten the lock nut until you start to feel some resistance with the fork.
6. Try to close the handle. If it closes easily, open it up, and tighten the lock nut further. If it is too difficult to close, open the handle up, and loosen the lock nut a little and try again.
7. The quick release handle should be difficult to push closed with your palm, but should be possible. Practice opening and closing the handle until you feel comfortable. DO NOT attempt to tighten the wheel by turning the handle to tighten; the handle is for closing, the lock nut (opposite side) is for adjusting the tension. (Fig. 3.12)

Next go back and check that the handlebars are perpendicular to the front wheel, go back to handlebar assembly and re-adjust if needed.



All quick release levers should be inspected before every ride to be sure they are fully closed and secure. Failure to properly close a quick release lever can cause loss of control of the bicycle resulting in injury or death.



Make sure the wheel is properly seated and the quick release is properly closed.

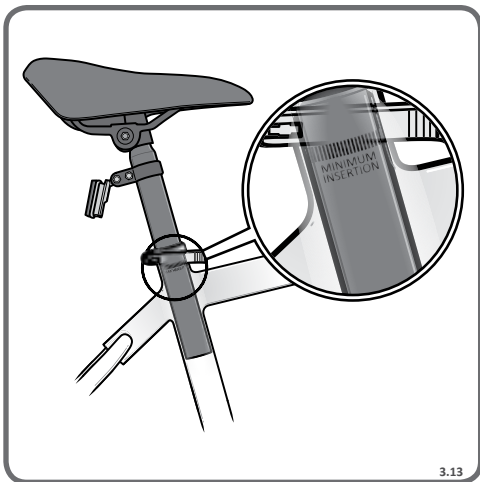

3.13

SADDLE ASSEMBLY



The seat post must be inserted so that the minimum insertion mark cannot be seen. The quick release mechanism must be tightened securely to prevent a sudden shift of the seat when riding. Failure to do this may cause loss of bicycle control.

The saddle assembly should be adjusted with the saddle centered on the rails and level. Locate the saddle assembly and insert into the frame. It is recommended to add some grease to all threads and binders on a bicycle, especially on the outside of the seat post. Otherwise it may corrode over time, and not be able to be adjusted again.

Bolted Seat Clamp

If your bicycle has a seat clamp with a bolt, adjust seat to desired height, and tighten the clamp so that the saddle may not turn left or right, or move up or down. Be sure that the seat post is inserted far enough into the frame to hide the “Minimum insertion” mark on the seat post. Riding a bicycle with the seat post above this line is dangerous and can cause injury to the rider or damage to the bicycle or create an unstable riding position causing an accident. (Fig. 3.13)

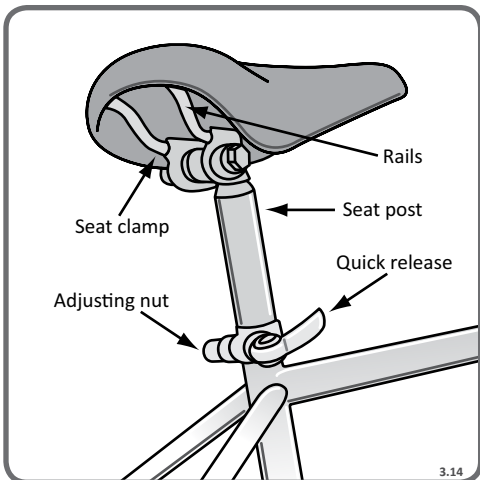

3.14

Quick Release Seat Clamp

If your bicycle has a seat clamp with a quick release, adjust seat to desired height, and tighten the quick release clamp so that the saddle may not turn left or right, or move up or down. If the saddle moves after locking the quick release lever, open the lever, and tighten the adjusting nut further, then close the quick release lever again. Be sure that the seat post is inserted far enough into the frame to hide the “Minimum insertion” mark on the seat post. Riding a bicycle with the seat post above this line is dangerous and can cause injury to the rider or damage to the bicycle or create an unstable riding position causing an accident.

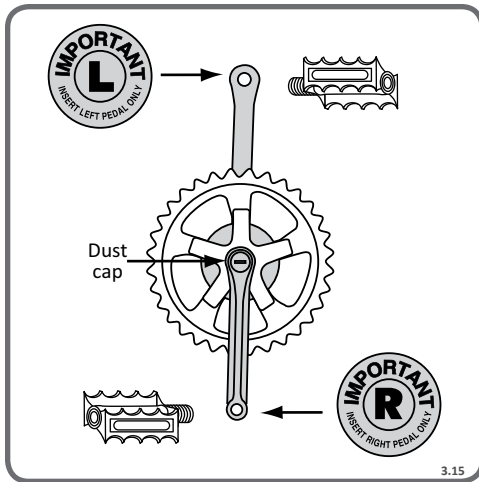

PEDALS AND CRANKS



Attachment of an incorrect pedal into a crank arm can strip pedal threads and cause irreparable damage. Before your first ride, please check to ensure your pedals are attached correctly.

Look for the letters “R” for right, and “L” for left, stamped on each pedal spindle. Start each pedal spindle by hand to avoid stripping the threads. (Note that the right hand pedal attaches to the chainwheel side crank arm with a right-hand (clockwise) thread. The left pedal attaches to the other crank arm and has a left-hand (counter-clockwise thread). Tighten with a 15mm narrow open ended wrench. It is very important that you check the crank set for correct adjustment and tightness before riding your bicycle.

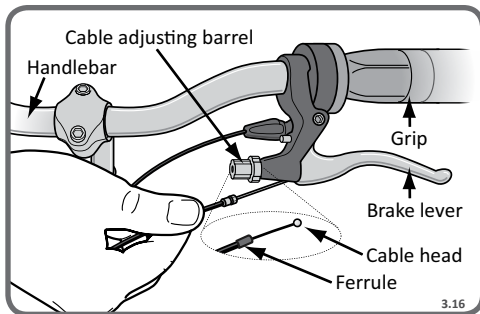

3.16

FRONT BRAKE



CAUTION: Improper use of the front brake may cause front wheel to lock up resulting in loss of directional control or front pitch over.

Determine which type of brake your bike is equipped with and refer to the appropriate assembly instructions below. *Additionally some freestyle models may be equipped with a "cable detangler". See assembly steps for cable detangler.

Caliper Brake

If the brake cable is not connected at the brake lever, slide the head of the brake cable into the brake lever per the diagram, and thread the cable through the slot in the brake lever so the cable end rests squarely in the adjustment barrel or cable end rests in the recess of the brake lever. (Fig. 3.16)

Brake adjustment

If the brake cable is disconnected at the caliper, thread the brake wire through the adjustment barrel, loosen the cable anchor bolt until you can see a hole through the anchor bolt for the cable wire to attach, thread the cable wire through the cable anchor and snug the cable anchor by hand. (Fig. 3.17)

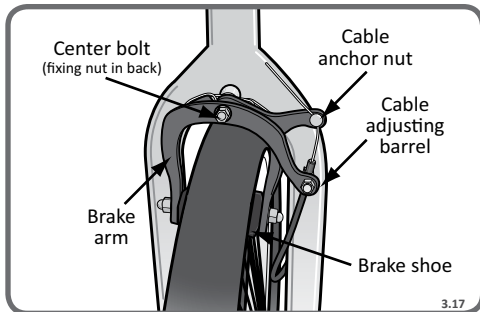

3.17

Check to be sure the cable is seated in the brake lever. Loosen the cable anchor bolt just enough to allow the cable wire to move freely. With your left hand squeeze the caliper brake until both brake pads contact the rim. While holding the brake closed with your left hand, use your right hand to pull the brake cable tight (through the cable anchor) again inspecting that the cable end is seated in the brake lever, and the barrel adjuster of the brake. Tighten the cable anchor as much as you can by hand, and then while still squeezing the brake, tighten the cable anchor fully with a wrench. (Fig. 3.18)

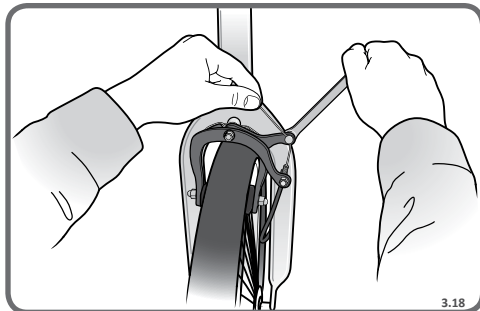

3.18

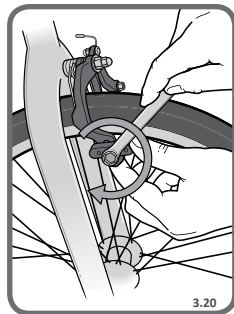
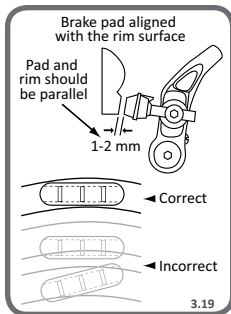

Check the brake pads to be sure they are square to the rim, and do not contact the tire when the brake is applied. Adjust brake pads if needed. Then squeeze and release the brake several times squeezing as hard as you can. After this the cable may “stretch” and need to be tightened further. If so, repeat cable tightening steps. (Fig. 3.19)

Centering brake

If you squeeze the brake and one side moves more than the other, or one side does not move at all, then the brake is not centered, or the wheel is not centered. First determine if the wheel is centered. Look at the gap between the tire and the fork or frame on either side. If it is not even, loosen wheel axle nuts and center the wheel, then proceed to centering the brake. (Fig. 3.20)

If the brake is not centered; loosen the nut on the back of the brake. Squeeze the brake and hold the brake lever closed, while re-tightening the lock nut on the back of the brake. Watch the brake, if it begins to shift or rotate, then release the brake lever, and use your hand to rotate the brake caliper back until both sides of the brake move equally. Sometimes it is necessary to over rotate the brake slightly, so that as you tighten the locknut, the brake will end up centered. Repeat the steps until the brake is centered.

Brake is correctly adjusted when:

- The brake pads do not drag on the rim when the brake is open.
- Both brake pads move away from the rim equally when the brake is released.
- When the brake is applied, the brake pads contact the rim before the brake lever reaches about 1/3 of the way to the handlebar. (Fig. 3.21)

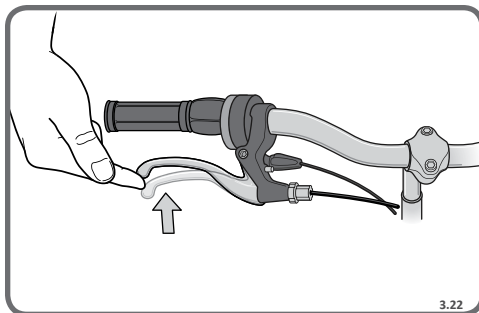
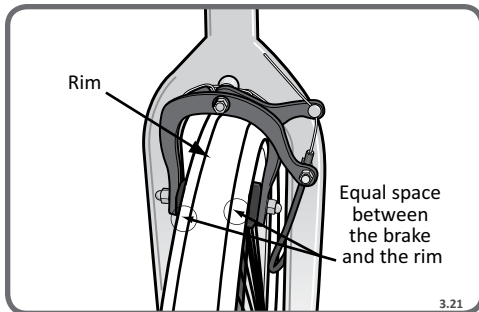

After adjusting brake, squeeze the brake lever as hard as you can several times and re-inspect the brake pads, centering, and brake lever travel. If the brake pads are no longer square to the rim, repeat brake pad adjustments. Be sure that brake pads return to a centered position by spinning the wheel and listening for the brake pad rubbing the rim on either side. Readjust as needed. Check that the brake cable tension allows the brake lever about 1/3 of the travel before the brake pads contact the rim. If the cable has stretched or slipped, readjust brake cable tension by loosening cable anchor bolt and pulling more cable through the anchor or use brake adjustment barrels for fine tuning brake cable tension.

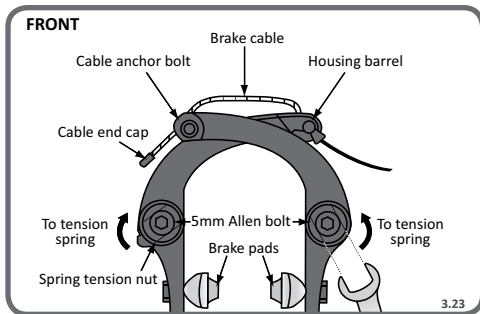

U-Brake

If the brake cable is not connected at the brake lever, slide the head of the brake cable into the brake lever per the diagram, and thread the cable through the slot in the brake lever so the cable end rests squarely in the adjustment barrel or cable end rests in the recess of the brake lever. (Fig. 3.16)

Brake adjustment

Check to be sure the cable is seated in the brake lever. Loosen the cable anchor bolt just enough to allow the cable wire to move freely. With your left hand squeeze the caliper brake until both brake pads contact the rim. While holding the brake closed with your left hand, use your right hand to pull the brake cable tight (through the cable anchor) again inspecting that the cable end is seated in the brake lever, and the barrel adjuster of the brake. Tighten the cable anchor as much as you can by hand, and then while still squeezing the brake, tighten the cable anchor fully with a wrench.

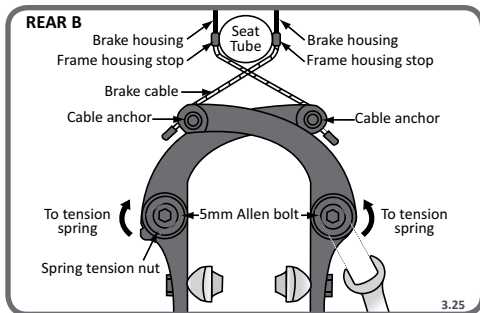
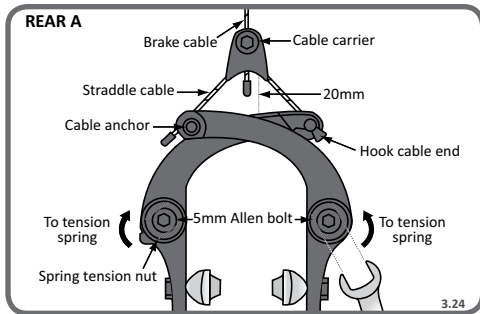

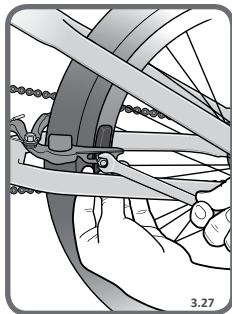
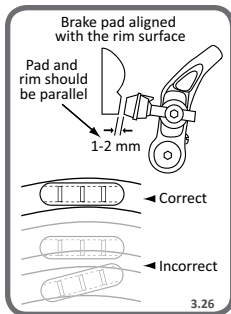

Check the brake pads to be sure they are square to the rim, and do not contact the tire when the brake is applied. Adjust brake pads if needed. Then squeeze and release the brake several times squeezing as hard as you can. After this the cable may “stretch” and need to be tightened further. If so, repeat cable tightening steps. (Fig. 3.27)

Centering brake

If you squeeze the brake and one side moves more than the other, or one side does not move at all, then the brake is not centered, or the wheel is not centered. First determine if the wheel is centered. Look at the gap between the tire and the fork or frame on either side. If it is not even, loosen wheel axle nuts and center the wheel, then proceed to centering the brake. (Fig. 3.28)

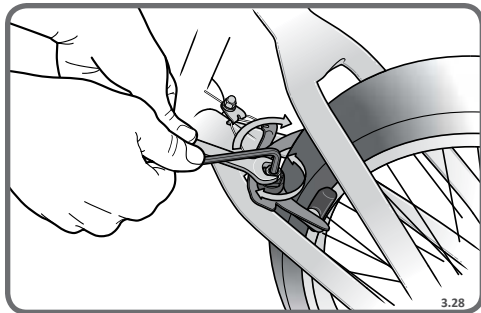

If the brake is not centered; determine which side of the brake needs to move, and use a wrench and Allen wrench to adjust the spring tension on that side. To do this, hold the outer nut of the spring tension assembly with a wrench and carefully loosen the center Allen bolt until you can move the nut with the wrench. Turn the spring tension nut with the wrench until the brake pad starts to move away from the rim. Hold the nut still at the place where both brake pads are an equal distance away from the rim. While keeping the nut still, re-tighten the Allen bolt. Squeeze the brake lever a few times to be sure that the brake is centered. Repeat above centering steps if needed.

Brake is correctly adjusted when:

- The brake pads do not drag on the rim when the brake is open.
- Both brake pads move away from the rim equally when the brake is released.
- When the brake is applied, the brake pads contact the rim before the brake lever reaches about 1/3 of the way to the handlebar. (Fig. 3.29)

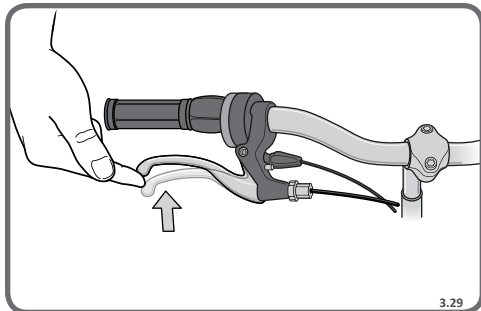

After adjusting brake, squeeze the brake lever as hard as you can several times and re-inspect the brake pads, centering, and brake lever travel. If the brake pads are no longer square to the rim, repeat brake pad adjustments. Be sure that brake pads return to a centered position by spinning the wheel and listening for the brake pad rubbing the rim on either side. Readjust as needed. Check that the brake cable tension allows the brake lever about 1/3 of the travel before the brake pads contact the rim. If the cable has stretched or slipped, readjust brake cable tension by loosening cable anchor bolt and pulling more cable through the anchor or use brake adjustment barrels for fine tuning brake cable tension.

Cable Detangler

Some freestyle bicycles are equipped with a cable detangler for the rear brake. See diagram of the cable routing. If the upper cable is not already assembled, insert the cable barrel end into the right (rear) brake lever. Adjust the brake lever adjustment barrel so that the slots line up with the brake lever and insert the upper cable through the brake barrel slots. Rotate the barrel so that the slots are no longer in line. Note that on the upper cable, one of the cable casings is shorter than the other. The shorter side should be on the right. This is the shorter distance between the brake lever and the upper detangler plate. Thread the adjusting barrels in on both sides, and hook the cable ends into the bearing unit. Note that the lower cable should already be hooked into the lower tabs of the bearing unit. (Fig. 3.28)

Next try squeezing the brake lever several times to be sure all the cables are seated in the adjustment barrels. If there is excess play before the brake cable starts to move, this can be adjusted by unscrewing one or more of the adjustment barrels.

First adjust the barrel adjuster at the mid point of the upper cable until the brake lever does not have any free play. Next squeeze the brake lever and allow it to return. Check to see if the bearing unit bottoms out on the lower detangler plate? If so, unscrew the adjust barrel further until the bearing unit sits about 1mm above the lower plate. This is the correct position for the bearing unit.

Rotate the handlebars back and forth, and then turn them completely around 360 degrees. Note whether the bearing unit spins quietly, or if it “flops” back and forth? If it has any flop, this can be fine tuned with the 4 adjustment barrels in the upper and lower detangler plates.

The goal is to reduce or eliminate as much of the flop as possible, while keeping the brake function consistent. While turning the handlebars 360 degrees, note whether the plate flops forward and back, or if it flops the same way. If it flops forward and back, adjust the upper cable barrel adjusters until the flop is reduced. If the flop is the same way, then adjust the lower cables until the flop is reduced. Sometimes both need to be adjusted. The best thing to do is to adjust the lower cables first until the bearing unit has an equal gap on the left and right sides, then adjust the upper barrel adjusters until the flop is minimal or none at all.

Now follow the brake adjustments for the type of brake the bike is equipped with (Caliper or U brake).

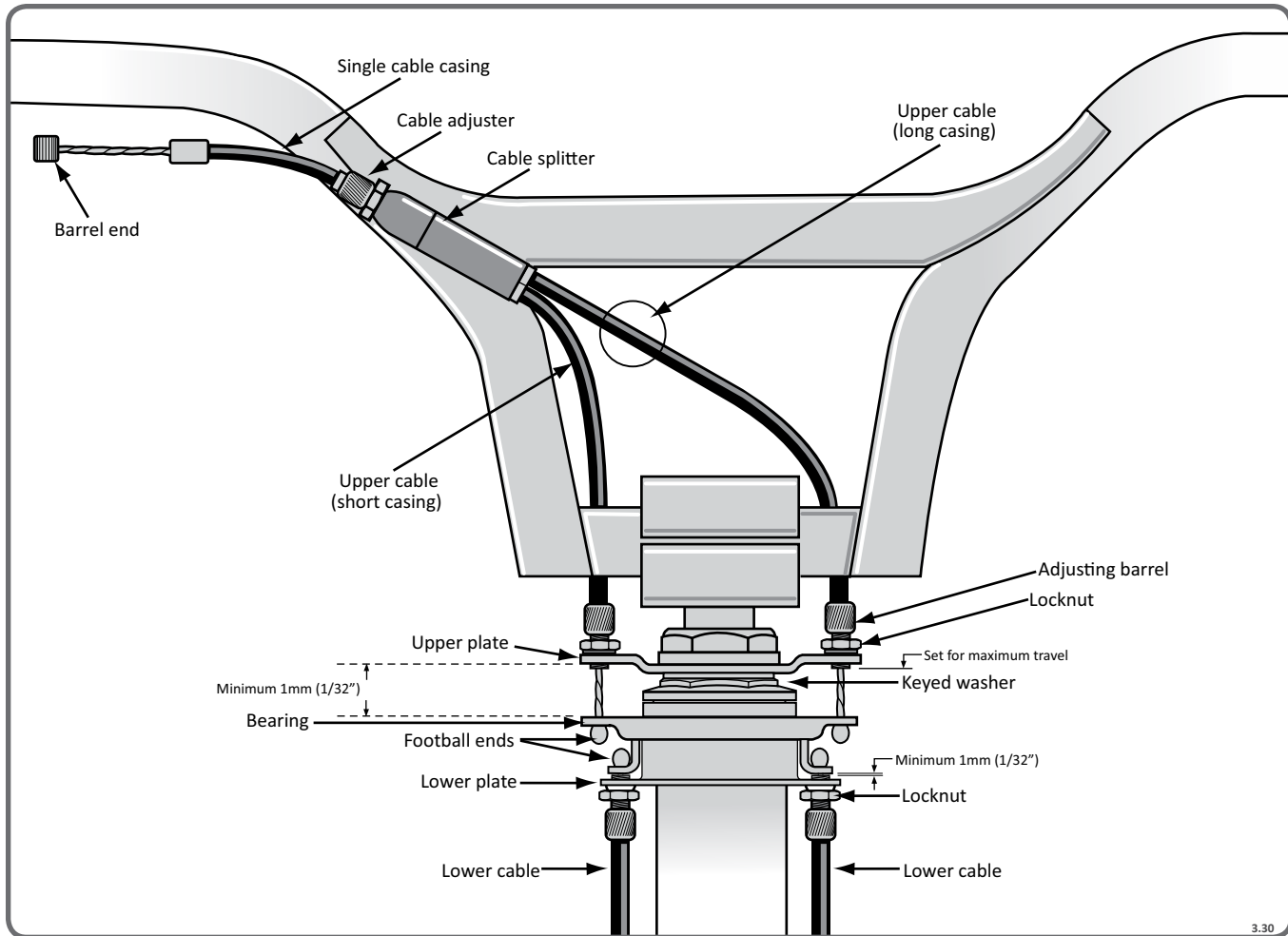

3.30

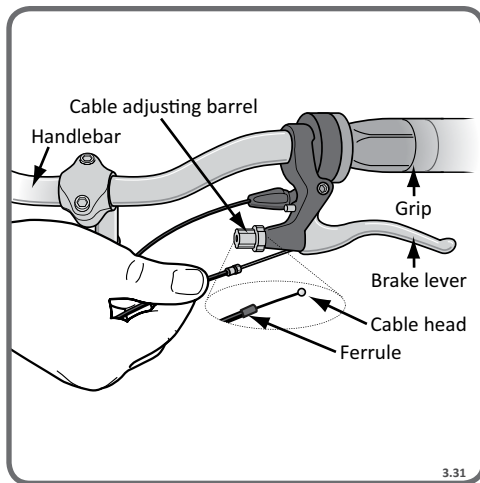

3.31

Linear Pull Brakes

If the brake cable is not connected at the brake lever, slide the head of the brake cable into the brake lever per the diagram, and thread the cable through the slot in the brake lever so the cable end rests squarely in the adjustment barrel or cable end rests in the recess of the brake lever. (Fig. 3.31)

If the brake cable is disconnected at the brake arm, with left hand, squeeze the 2 brake halves together until the brake pads touch the rims. With your right hand pull the brake cable so that the stepped end of the “noodle” can be inserted into the brake carrier.

Brake adjustment

Check to be sure the cable is seated in the brake lever. Loosen the cable anchor bolt just enough to allow the cable wire to move freely. With your left hand squeeze the caliper brake until both brake pads contact the rim. While holding the brake closed with your left hand, use your right hand to pull the brake cable tight (through the cable anchor). Again inspecting that the cable end is seated in the brake lever, and the barrel adjuster of the brake. Tighten the cable anchor as much as you can by hand, and then while still squeezing the brake, tighten the cable anchor fully with a wrench. (Fig. 3.32)

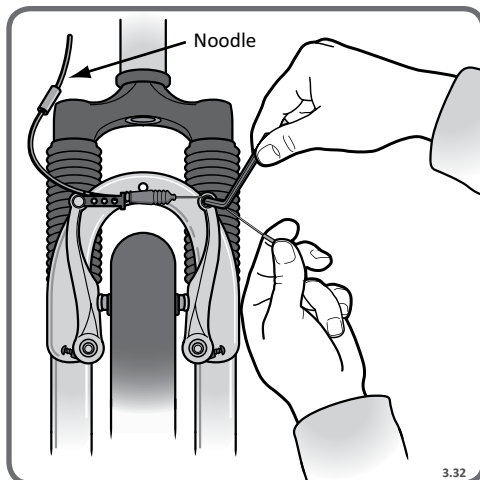

3.32

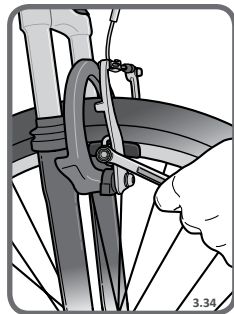
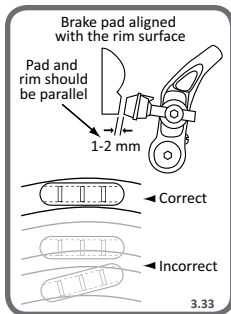

Check the brake pads to be sure they are aligned with the rim, and that they do not contact the tire when the brake is applied. Adjust brake pads if needed. Then squeeze and release the brake several times squeezing as hard as you can. After this the cable may “stretch” and need to be tightened further. If so, repeat cable tightening steps. (Fig. 3.34)

Centering brake

If you squeeze the brake and one side moves more than the other, or one side does not move at all, then the brake is not centered, or the wheel is not centered. First determine if the wheel is centered. Look at the gap between the tire and the fork or frame on either side. If it is not even, loosen wheel axle nuts and center the wheel, then proceed to centering the brake.

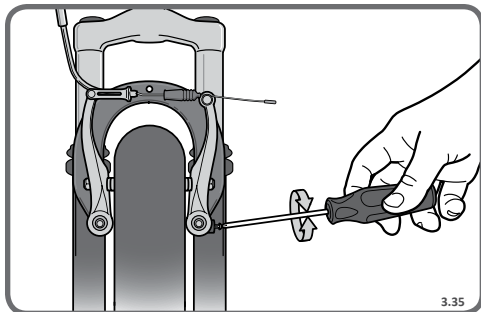

If the brake is not centered; use a Phillips screwdriver to tighten or loosen the screws on either side of the linear pull brake where they mount to the frame or fork. If you turn the screw clockwise it will increase spring tension on that side, counter clockwise to decrease spring tension. Start by increasing tension on the side that is not moving or not moving enough. Turn only about ½ turn at a time, and try squeezing and releasing the brake lever a few times to see the difference. Repeat until the brake is centered. If you run out of adjustment, you can go to the other side and loosen the screw slightly to continue adjusting the brake. When the brake is correctly adjusted, both sides should move evenly when the brake lever is squeezed, and when released, the wheel should rotate with no brake shoe contact. (Fig. 3.35)

Brake is correctly adjusted when:

- Both brake pads move away from the rim equally when the brake is released.
- The brake pads do not drag on the rim when the brake is open.
- When the brake is applied, the brake pads contact the rim before the brake lever reaches about 1/3 of the way to the handlebar (Fig. 3.36)

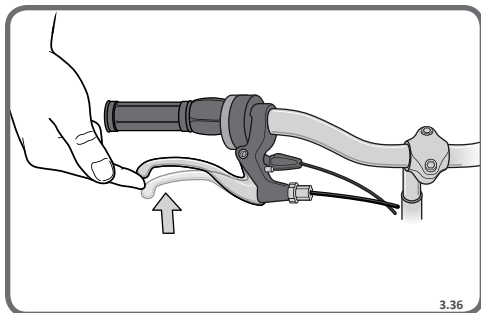

After adjusting brake, squeeze the brake lever as hard as you can several times and re-inspect the brake pads, centering, and brake lever travel. If the brake pads are no longer square to the rim, repeat brake pad adjustments. Be sure that brake pads return to a centered position by spinning the wheel and listening for the brake pad rubbing the rim on either side. Readjust as needed. Check that the brake cable tension allows the brake lever about 1/3 of the travel before the brake pads contact the rim. If the cable has stretched or slipped, readjust brake cable tension by loosening cable anchor bolt and pulling more cable through the anchor or use brake adjustment barrels for fine tuning brake cable tension.

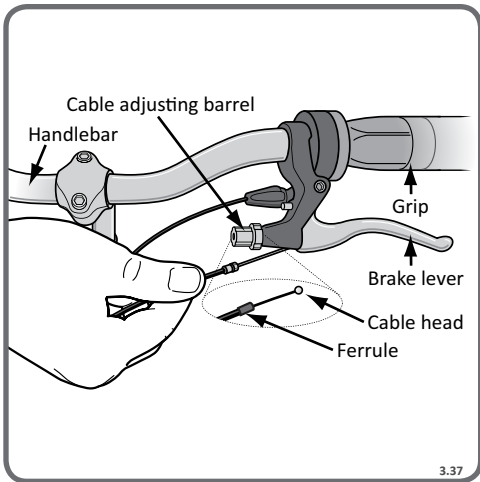

Disc Brake

If the brake cable is not connected at the brake lever, line up brake barrel slots with brake lever slot before installing the cable. Then slide the head of the brake cable into the brake lever per the diagram, and thread the cable through the slot in the brake lever so the cable end rests squarely in the adjustment barrel or cable end rests in the recess of the brake lever. (Fig. 3.37)

If the brake cable is disconnected at the disc caliper, thread the brake wire through the adjustment barrel, loosen the cable anchor bolt until you can see a hole through the anchor bolt for the cable wire to attach, thread the cable wire through the cable anchor and snug the cable anchor by hand. (Fig. 3.38)

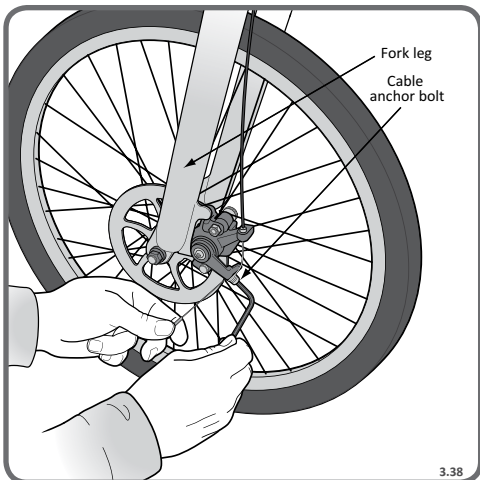

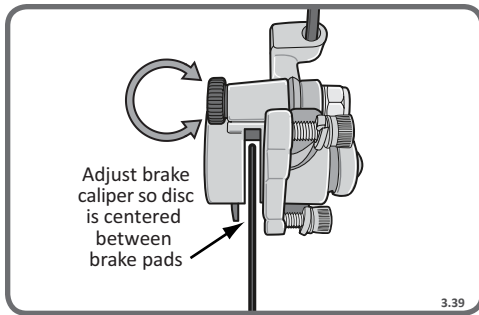

3.39

Centering brake

If you squeeze the brake and one side moves more than the other, or one side does not move at all, then the brake is not centered, or the wheel is not centered. First determine if the wheel is centered. Look at the gap between the tire and the fork or frame on either side. If it is not even, loosen wheel axle nuts and center the wheel, then proceed to centering the brake. (Fig. 3.39, 3.40)

If the brake is not centered, look at the disc brake caliper for centering adjustment screws at the center of the brake pad on either side. (Fig. 3.39) Looking down into the brake where the brake pads contact the disc rotor, determine which side needs to move away or towards the disc. Turn the centering adjustment screws so that there is about 1/32 of an inch of clearance on either side of the disc rotor. Spin the front wheel and listen for any rubbing noise or excess friction. Repeat the steps until the brake is centered.

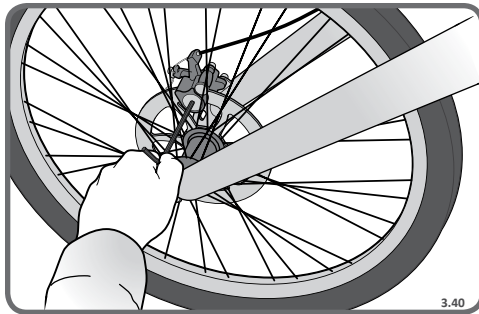

3.40

Brake is correctly adjusted when:

- The brake pads do not drag on the rotor when the brake is open.
- Both brake pads move away from the rotor equally when the brake is released.
- When the brake is applied, the brake pads contact the rim before the brake lever reaches about 1/3 of the way to the handlebar. (Fig. 3.41)



DISC GETS HOT! Severe injury could result from contact with the hot disc! Mind your legs, as well as your hands.

These brakes require breaking in! Ride and use the brakes gently for 13 miles before using the brakes in downhill conditions, for sudden stops, or any other serious braking. Please be aware that your brake system will change in performance throughout the wear-in process. The disc brake should be cleaned before the first ride using rubbing alcohol. NEVER use oil or similar products to clean your disc brake system.



WARNING: Disc brakes are sharp, keep fingers away from brake caliper and rotor. If fingers contact brake while wheel is turning injury can occur.

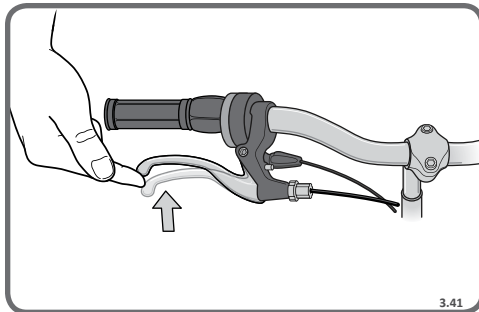

3.41

After adjusting brake, squeeze the brake lever as hard as you can several times and re-inspect the brake pads, centering, and brake lever travel. If the brake pads are no longer square to the rim, repeat brake pad adjustments. Be sure that brake pads return to a centered position by spinning the wheel and listening for the brake pad rubbing the rotor on either side. Readjust as needed. Check that the brake cable tension allows the brake lever about 1/3 of the travel before the brake pads contact the rotor. If the cable has stretched or slipped, readjust brake cable tension by loosening cable anchor bolt and pulling more cable through the anchor or use brake adjustment barrels for fine tuning brake cable tension.

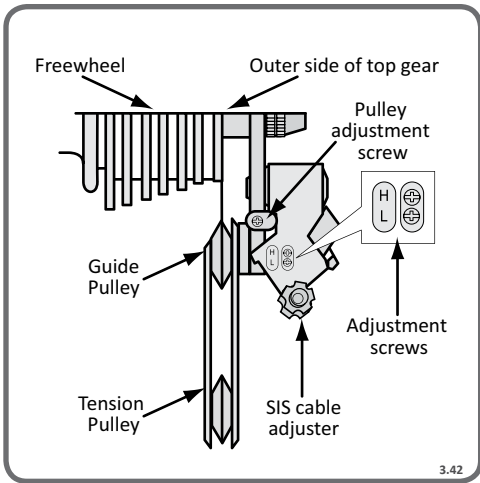

DERAILLEUR

Although the front and rear derailleurs are initially adjusted at the factory, you will need to inspect and readjust both before riding the bicycle.

Rear Derailleur

Begin by shifting the rear shifter to largest number indicated and place the chain on the smallest sprocket. Adjust the High limit screw so the guide pulley and the smallest sprocket are lined up vertically. Reconnect the cable, pull out any slack, and retighten the anchor bolt securely. Shift through the gears, making sure each gear achieved is done quietly and without hesitation. If necessary, use the barrel adjuster to fine tune each gear by turning it the direction you want the chain to go. For example, turning clockwise will loosen the cable tension and move the chain away from the wheel, while turning counter-clockwise will tighten cable tension and direct the chain towards the wheel. Shift the rear shifter to the gear one and place the chain on the largest cog. Adjust the Low limit screw in quarter turn increments until the guide pulley and the largest cog are aligned vertically. Again, shift through each gear several times, checking that each gear is achieved smoothly. It may take several attempts before the rear derailleur and cable is adjusted properly. (Fig. 3.42, 3.43)

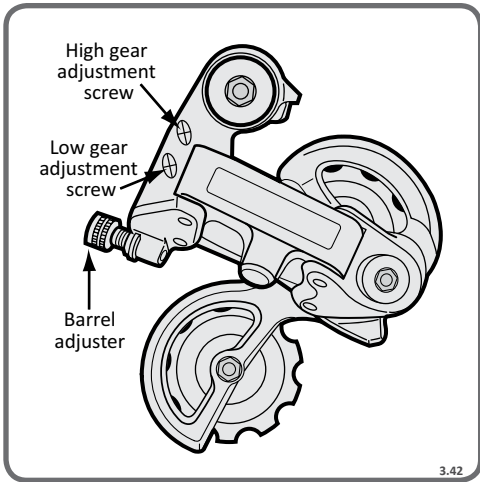

Ensure all bolts are secured tightly and the chain does not fall off in either direction.

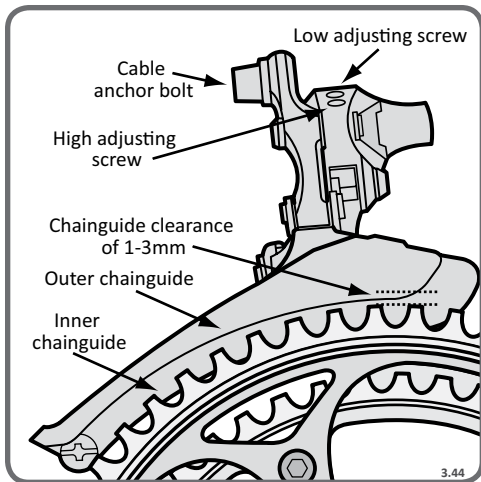

Front Derailleur

(Fig. 3.44) Shift both shifters to the smallest number indicated and place the chain on the corresponding cog and chainwheel. Disconnect the front derailleur cable from the cable anchor bolt. Check the position of the front derailleur; it should be parallel with the outer chainwheel and clear the largest chainwheel by 1-3mm when fully engaged. With the chain on the smallest chainwheel in front and the largest cog in back, adjust the Low limit screw so the chain is centered in the front derailleur cage. Reconnect the cable, pull any slack out, and tighten the anchor bolt securely. Shift the front shifter to the largest chainwheel. If the chain does not go onto the largest chainwheel, turn the high limit screw in 1/4 turn increments counter-clockwise until the chain engages the largest chainwheel. If the chain falls off the largest chainwheel, and into the pedals, you will need to turn the High limit screw in 1/4 turn increments clockwise until the chain no longer falls off. Shift through every gear, using the barrel adjusters to fine tune each transition. The barrel adjuster for the front derailleur is located on the front shifter where the cable comes out of the shifter. Clockwise will loosen the cable tension and direct the chain closer to the frame while counter-clockwise will tighten the cable tension and direct the chain away from the frame.



Do not ride a bicycle that is not shifting properly. Overlooking proper adjustments may cause irreparable damage to the bicycle and/or bodily injury. Never move the shifter while pedaling standing up, or under heavy load, nor pedal backwards after having moved the shifter. This could jam the chain and cause serious damage to the bicycle and/or rider.

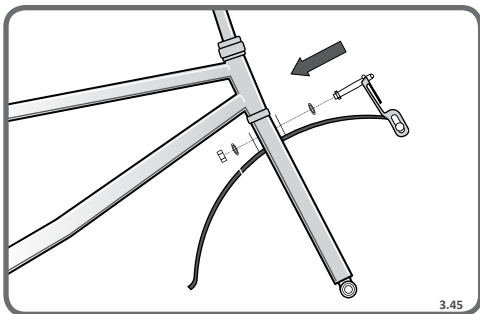

FRONT FENDER - if equipped

The front fender is mounted at the fork crown. There are two ways in which to mount your front fender. The first is the caliper brake mounting system (see Fig. 3.45), and the second is the 10mm nut and bolt system (see Fig. 3.46). Identify the mounting system used on your bicycle and follow the given instructions for that particular type of mounting system.

(Fig. 3.45) Caliper Brake Mounting System

First remove the front wheel from your bicycle. Remove the hex nut from the caliper brake bolt on the rear of the fork, and slide the brake assembly from the fork. Place the fender assembly onto the fork making sure the attachment holes and fender bracket holes line up. Reattach the caliper brake making sure that the brake arms are on each side of the fender. Tighten the bolt until secure.

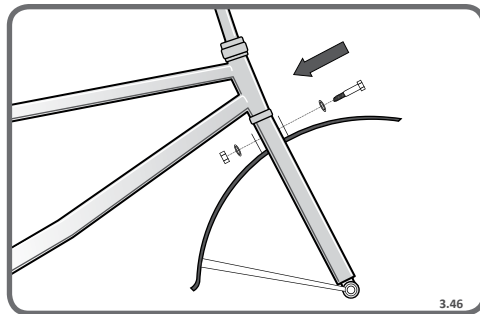

(Fig. 3.46) 10mm Nut and Bolt Mounting System

First remove the front wheel from your bicycle. Place the fender assembly onto the fork making sure the attachment holes and fender bracket holes line up. Attach the fender with the 10mm hex bolt and nut. Tighten the bolt until secure.

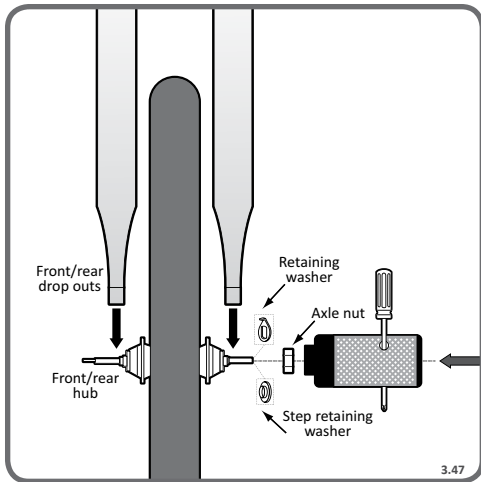

PEGS

Some models may come equipped with 2 or 4 pegs. To install pegs, **DO NOT** loosen or remove axle nuts. Check to make sure axle nuts are properly tightened before installing pegs. Thread the pegs on the axle over the axle nut, and insert a screwdriver or similar tool through the peg holes and tighten by turning the peg with the tool. (Fig. 3.47)



Periodically check to make sure pegs are tight.

TRAINING WHEELS

Attaching training wheel brace to bicycle

There are three different braces used to attach the training wheels to the bicycle: the c-shape brace, the flat brace and the flat brace with stabilizer. Determine which brace was included with your bicycle and follow the given instructions for that particular brace.

C-Shape Brace

Remove the outer axle nut and washer from the rear wheel axle. Place the brace stabilizer washer onto the axle and align the washer so that the notch on the washer fits into the rear frame drop out. Next, place the C-shaped wheel brace onto the axle and replace the washer and axle nut. Tighten the axle nut securely, making sure that the wheel brace stays in the proper vertical position. The elongated hole on the wheel brace allows the training wheel height to be adjusted for proper fit. (Fig. 3.48)

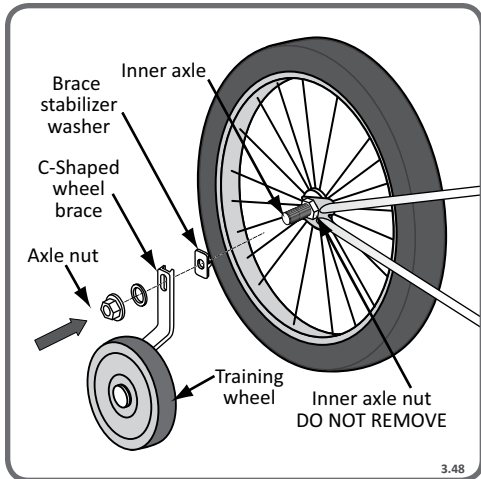

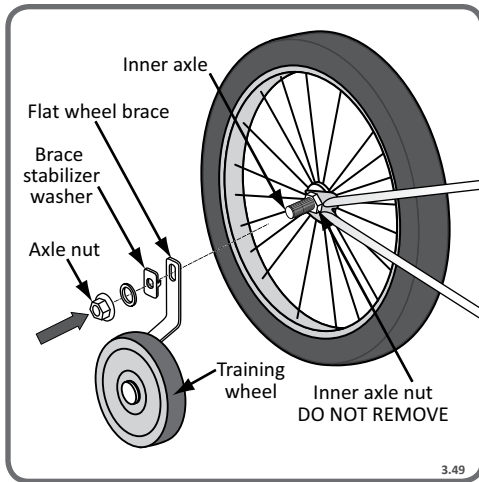

Flat Brace



It is very important to check the training wheel connection to the bicycle. Failure to properly tighten may cause the training wheel to dislodge. Please contact Cycling Sports Group Service with any questions.

Remove the outer axle nut and washer from the rear wheel axle. Place the flat wheel brace onto the axle. Next place the brace stabilizer washer onto the axle and align it so that the notch fits into the rear frame drop out. Replace the washer and axle nut. Tighten the axle nut securely, making sure that the wheel brace stays in the proper vertical position. The elongated hole on the wheel brace allows the training wheel height to be adjusted for proper fit. (Fig. 3.49)

Training Wheel Stabilizer Bracket

Remove the outer axle nut and washer from the rear wheel axle. Insert the wheel brace into the stabilizer bracket so that the forked end of the stabilizer bracket faces in. Slide assembly onto the rear axle so that the forked end hooks around the chain stay of the bicycle. Replace the axle nut and washer, secure tightly. The elongated hole on the brace allows for raising and lowering the training wheel to the proper height. (Fig. 3.50)

NOTICE: Not all bicycles will accept training wheels. If your bike did not come stock with training wheels, please call Cycling Sports Group to help determine if after-market

can be attached.

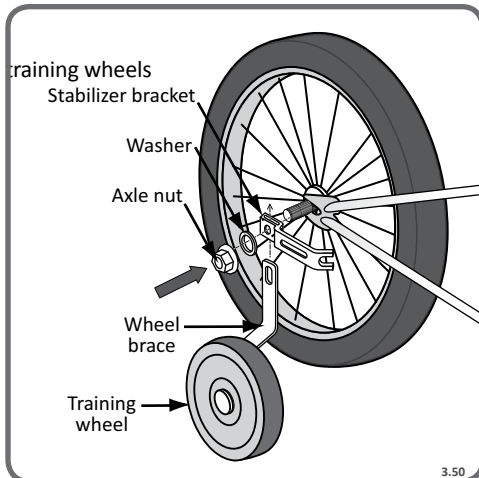

FINAL CHECK

 **Never inflate a tire beyond the maximum pressure marked on the tire's sidewall. Exceeding the recommended pressure may blow the tire off the rim, which could cause damage to the bicycle and injury to the rider and bystanders.**

 **Tighten both front/rear wheel axle nuts or the quick release mechanism securely. Failure to do this may cause the front/rear wheel to dislodge from the frame dropouts resulting in serious damage or injury.**

- After all adjustments have been made, shift through every gear several times at varying speeds. This will ensure all your adjustments are correct and will allow you to pinpoint any trouble areas. If you encounter any problems, refer to the appropriate section and make any necessary adjustments.
- Check the tire pressure and inflate each tube to the recommended psi as stated on the sidewall of the tire.
- Check that the kickstand operates smoothly and the kickstand bolt is secured tightly.
- Finally, examine the bicycle. Make sure all accessories are attached and all quick releases, nuts and bolts have been tightened securely.
- Correct maintenance of your bicycle will ensure many years of happy riding. Service your bicycle regularly by referring to the relevant sections of this manual, OR take it to a professional bicycle shop. Remember: Always wear a helmet and obey all traffic laws.

Correct routine maintenance of your new bike will ensure:

Smooth running - Longer lasting components - Safer riding - Lower running costs

Every time you ride your bicycle, its condition changes. The more you ride, the more frequently maintenance will be required. We recommend you spend a little time on regular maintenance tasks. The following schedules are a useful guide and by referring to Part 5 of this manual, you should be able to accomplish most tasks. If you require assistance, we recommend you see a bicycle specialist.



WARNING: Do not over lubricate. If lubricant gets on rims, tires or brake shoes, it will reduce control and braking performance and may require a longer stopping distance. Injury to the rider can occur. Avoid getting any excess lubrication on these areas by wiping off excess lubricant, and keeping these areas clean and dry.

LUBRICATION

Frequency	Component	Lubricant	How to Lubricate
Weekly	Chain Derailleur wheels Derailleurs Brake calipers Brake levers	Chain lube or light oil Chain lube or light oil Oil Oil Oil	Brush on or squirt Brush on or squirt Oil can 3 drops from oil can 2 drops from oil can
Monthly	Shift levers	Lithium based grease	Disassemble
Every Six Months	Freewheel Brake cables	Oil Lithium based grease	2 squirts from oil can Disassemble
Yearly	Bottom bracket Pedals Derailleur cables Wheel bearings Headset Seat pillar	Lithium based grease Lithium based grease Lithium based grease Lithium based grease Lithium based grease Lithium based grease	Disassemble Disassemble Disassemble Disassemble Disassemble Disassemble

NOTE: The frequency of maintenance should increase with use in wet or dusty conditions. Do not over lubricate - remove excess lubricant to prevent dirt build up. Never use a degreaser to lubricate your chain (WD-40™).

WHEELS



Quick release: Check that these are set to the closed position and are properly tensioned before each ride.

CAUTION: Maintain the closed position and the correct adjustment. Failure to do so may result in serious injury.



Axle nuts: Check that these are tight before each ride.

It is most important that wheels are kept in top condition. Properly maintaining your bicycle's wheels will help braking performance and stability when riding. Be aware of the following potential problems:

- **Dirty or greasy rims.** **CAUTION:** These can render your brakes ineffective. Do not clean rims with oily or greasy materials. When cleaning, use a clean rag or wash with soapy water, rinse and air dry. Don't ride while they're wet. When lubricating your bicycle, don't get oil on the rim braking surfaces.
- **Wheels not straight:** Lift each wheel off the ground and spin them to see if they are crooked or out of true. If wheels are not straight, they will need to be adjusted. This is quite difficult and is best left to a bicycle specialist.
- **Broken or loose spokes:** Check that all spokes are tight and that none are missing or damaged. **CAUTION:** Such damage can result in severe instability and possibly an accident if not corrected. Again, spoke repairs are best handled by a specialist.
- **Loose hub bearings:** Lift each wheel off the ground and try to move the wheel from side to side. **CAUTION:** If there is movement between the axle and the hub, do not ride the bicycle. Adjustment is required.

TIRES

Tires must be maintained properly to ensure road holding and stability. Check the following areas:

- **Inflation:** Ensure tires are inflated to the pressure indicated on the tire sidewalls. Use a pump that is designed for bicycle tires.



It is not recommended to use a gas station service pump to inflate bicycle tires. These pumps put out a high volume of air very quickly. Inflating a bicycle tire too quickly can cause the tire to blow off the rim damaging the bicycle, and possibly injuring the rider. Add a little bit of air at a time, and check that the tire is seated evenly on the rim on both sides. To check, pump the tire up to 20 psi, then remove the pump. Spin the wheel and watch the tire to see if it has any high or low areas. Use hands to pull tire into place. Spin the wheel again to be sure tire is correctly seated, and complete inflation. Check again when done. If the tire is not seated, release some or all of the air pressure and start over. An unseated tire can rupture unexpectedly causing a loss of control of the bicycle and result in injury of death.

- **Bead seating:** When inflating or refitting tire, make sure that the bead is properly seated in the rim.
- **Tread:** Check that the tread shows no signs of excessive wear or flat spots, and that there are no cuts or other damage. **CAUTION:** Excessively worn or damaged tires should be replaced.
- **Valves:** Make sure valve caps are fitted and that valves are free from dirt. A slow leak caused by the entry of the dirt can lead to a flat tire, and possibly a dangerous situation.



DETAILED MAINTENANCE

How to fix a flat tire

If you need to repair a tire, follow these steps:

1. Remove the wheel from the bicycle.
2. Deflate the tire completely via the valve. Loosen the tire bead by pushing it inward all the way around. (Fig. 4.1)
3. Press one side of the tire bead up over the edge of the rim. **NOTE:** Use tire levers, not a screwdriver, otherwise you may damage the rim. (A good substitute for tire levers are the handles of metal kitchen spoons, there are no sharp edges that may damage the tire or tube. (Fig. 4.2))
4. Remove the tube, leaving one tire bead on the rim.
5. Locate the leaks and patch using a tube repair kit, carefully following the repair kit instructions, or replace the tube. **NOTE:** Ensure that the replacement tube size matches the size stated on the tire sidewall and that the valve is the correct type for your bicycle.
6. Match the position of the leak in the tube with the tire to locate the possible cause and mark the location on the tire.
7. Remove the tire completely and inspect for a nail, glass, etc. and remove if located. Also inspect the inside of the rim to ensure there are no protruding spokes, rust or other potential causes. Replace the rim tape which covers the spoke ends, if damaged.
8. Remount one side of the tire onto the rim.
9. Using a hand pump, inflate the tube just enough to give it some shape.
10. Place the valve stem through the hole in the rim and work the tube into the tire. **NOTE:** Do not let it twist.
11. Using your hands only, remount the other side of the tire by pushing the edge toward the center of the rim. Start on either side of the valve and work around the rim. (Fig. 4.3)
12. Before the tire is completely mounted, push the valve up into the rim to make sure the tire can sit squarely in position.
13. Fit the rest of the tire, rolling the last, most difficult part on using your thumbs. **NOTE:** Avoid using tire levers as these can easily puncture the tube or damage the tire.
14. Check that the tube is not caught between the rim and the tire bead at any point.
15. Using a hand pump, inflate the tube until the tire begins to take shape, and check that the tire bead is evenly seated all the way around the rim. When properly seated, fully inflate the tire to the pressure marked on the sidewall. Use a tire air pressure gauge to check.
16. Replace the wheel into the frame checking that all gears, brakes, axle nuts or quick release levers are properly tightened.

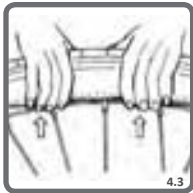
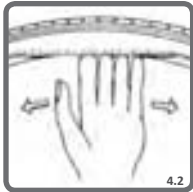

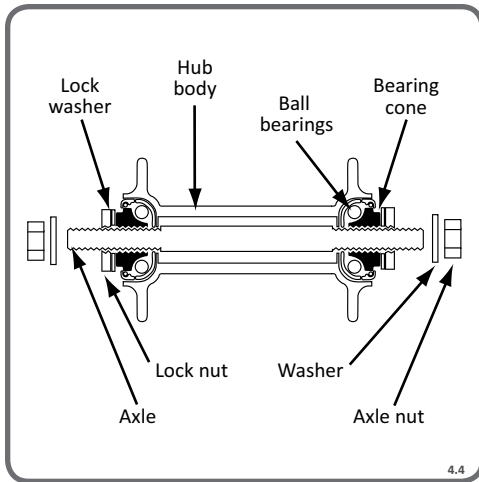

4.4

Hub Bearings

Hub bearings require special thin wrenches called “cone wrenches”. If you do not own these tools, do not attempt hub bearing adjustments. Have a qualified bicycle mechanic perform the adjustment if you have any doubts. (Fig. 4.4)

1. Check to make sure neither locknut is loose.
2. To adjust, remove wheel from bicycle and loosen the locknut on one side of the hub while holding the bearing cone on the same side with a cone wrench.
3. Rotate the adjusting cone as needed to eliminate free play.
4. Re-tighten the locknut while holding the adjusting cone in position.
5. Re-check that the wheel can turn freely without excessive side play.

Cables and Cable Housing

Cables and housing are one of the most overlooked parts on the bicycle. The first indication that your cables and housing need to be replaced is an increased amount of pressure needed to operate the brakes or shifters. Before every ride, check that there are no kinks or frays in the cables and housing. Also check that the housing is seated properly into each cable stop of the bicycle. It is recommended that the cables and housing are replaced at least every riding season to prolong the life of your bike. (Fig. 4.5)



Do not ride a bicycle that is not operating properly.

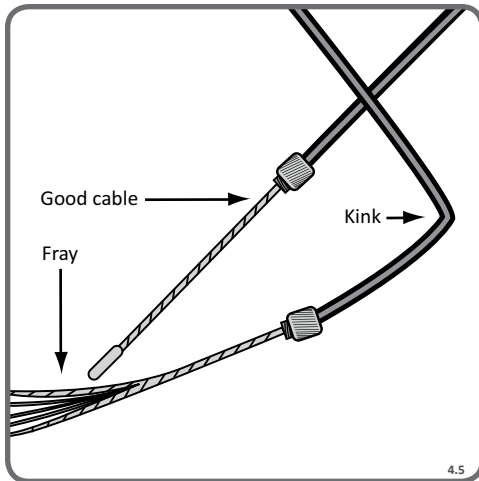

4.5

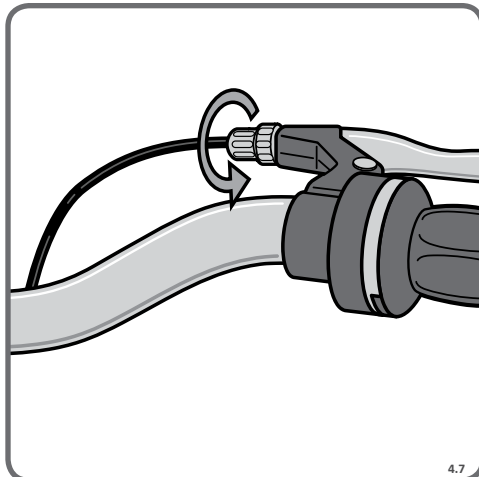
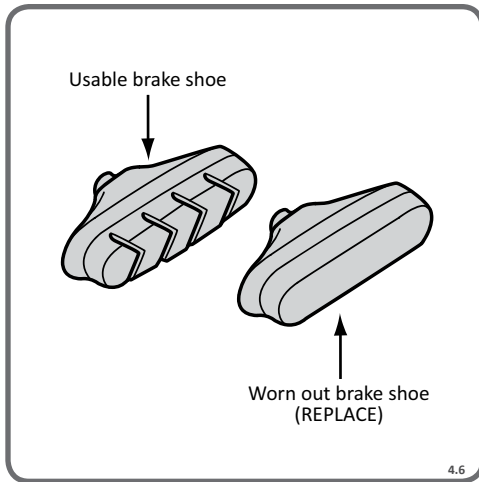

Brakes



Never ride a bicycle unless the brakes are functioning properly.

The correct adjustment and operation of your bicycle's brakes is extremely important for safe operation. Brakes should be checked for effective operation before every ride. Frequent checking of adjustment is necessary as the control cables will stretch and the brake pads will become worn with use. (Please refer to p. 32-41)

Inspection

Brake levers should be checked for tightness at least every three months. They should be set in a comfortable position within easy reach of the rider's hands, and must not be able to move on the handlebar. Some brake levers make use of a reach adjustment screw, which can alter the distance between the handlebar grip and the lever, as required. The brake pads should be checked for correct positioning and tightness before every ride, and the various bolts and nuts at least every three months. Squeeze each brake lever to make sure they operate freely and that the brake pads press hard enough on the rims to stop the bike. There should be about 1mm - 2mm clearance between each pad and the rim when the brakes are not applied. The brake pads must be properly centered for maximum contact with the rim. Replace the brake pads if they are over worn so that the grooves or pattern cannot be seen. The brake cable wires should be checked for kinks, rust, broken strands or frayed ends. The outer casing should also be checked for kinks, stretched coils and other damage. If the cables are damaged, they should be replaced. (Fig. 4.6)

Lubrication

The brake lever and brake caliper pivot points should be oiled with 2-3 drops of light oil at least every six months to ensure smooth operation and to reduce wear. Cables should be greased along their entire length, after removing them from their casings, at least every six months. Always grease new cables before fitting. Be sure to wipe off all excess lubrication from outer surfaces. If left the lubrication can get onto rim or brake surfaces and cause a loss of braking performance.

Adjustment

Minor brake adjustment can be made via the cable adjusting barrel, usually located at the brake lever. To adjust, squeeze the brake pads against the rim, loosen the lock nut and turn the adjuster. Brake pad clearance should be a maximum 2mm from the rim. (1/2mm for disc brakes) When correct, re-tighten the lock nut. If the pads cannot be set close enough to the rim in this manner, you may have to adjust the cable length.

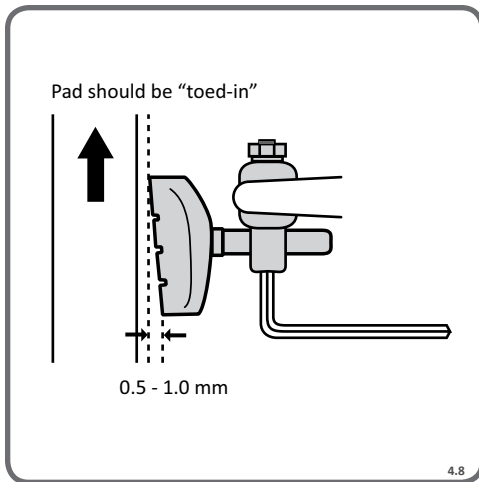

Screw the barrel adjuster 3/4 of the way in, squeeze the pads against the rim, undo the cable anchor bolt and pull the cable through with pliers. Re-tighten the cable anchor bolt and apply full force to the brake lever to test, then fine tune using the barrel adjuster. If one pad is closer to the rim than the other, loosen the fixing nut at the back of the brake, apply the brake to hold it centered, and re-tighten the fixing nut. (Fig. 4.7)

Ensure the Brake fixing nut is secured tightly. Failure to do this may cause the brake assembly to dislodge from the frame or fork.

Some brakes have a special mechanism which enables you to set the clearance on either side of the rim using a screwdriver. Brake pads should finally be adjusted so that the leading edge of the pad makes first contact with the rim. Some brakes have special curved washers to allow this, but on less complex models it will be necessary to apply a little force to the pad and its mounting. (Fig. 4.8)

Drivetrain

The drivetrain of a bicycle refers to all parts that transmit power to the rear wheel including the pedals, chain, chainwheel, crank set, and freewheel.

Pedals inspection

Pedals should be inspected every month, taking note of the following areas:

- Check correct tightness into the crank arms. If pedals are allowed to become loose, they will not only be dangerous but will also cause irreparable damage to the cranks.
- Check that pedal bearings are properly adjusted. Move the pedals up and down, and right to left, and also rotate them by hand. If you detect any looseness or roughness in the pedal bearings then adjustment, lubrication or replacement is required.
- Ensure that the front and rear pedal reflectors are clean and securely fitted.

Lubrication and adjustment

Many pedals cannot be disassembled to allow access to the internal bearings and axle. However, it is usually possible to inject a little oil onto the inside bearings, and this should be done every six months. If the pedal is the type that can be fully disassembled, then the bearings should be removed, cleaned and greased every six to twelve months. Because of the wide variety of pedal types and their internal complexity, disassembly procedures are beyond the scope of this manual and further assistance should be sought from a specialist.

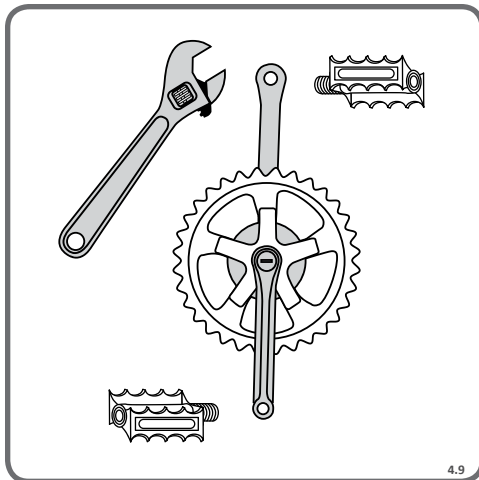



Note: The right and left pedals of a bicycle each have a different thread and are not interchangeable.

Never force a pedal into the incorrect crank arm. The right pedal, which attaches to the chainwheel side, is marked 'R' on the end of the axle, and screws in with a clockwise thread. The left pedal, which attaches to the other crank arm, is marked 'L' on the axle, and screws in with a counter-clockwise thread.

Insert the correct pedal into the crank arm and begin to turn the thread with your fingers only. When the axle is screwed all the way in, securely tighten using a 15mm wrench. **NOTE:** Never try and force a pedal with the wrong thread size into a bicycle crank.

Crank Set

The crank set refers to the bottom bracket axle and bearings, the crank arms, and chainrings. Your bike may be fitted with either a one piece crank, where the crank arms are connected as a single piece, or 3 piece cranks, where the crank arms bolt onto the bottom bracket axle. Never ride your bike if the cranks are loose. This may be dangerous and will damage the crank arms beyond repair.

Inspection

The crank set should be checked for correct adjustment and tightness every month. Bottom bracket bearings must be properly adjusted, and pedals should be tight. Remove the chain and try to move the cranks from side to side with your hands. The cranks should not move on the axle, and there should be only very slight movement in the bottom bracket. Next, spin the cranks. If they don't spin freely without grinding noise, then adjustment or lubrication will be needed. Also check that there are no broken teeth on the chainrings, and wipe off excess dirt and grease that may have built up on them.

Lubrication and adjustment - One Piece Cranks

To adjust the free play in a one piece type bottom bracket, loosen the locknut on the left side by turning it clockwise and tighten the adjusting cone counter-clockwise using a screwdriver in the slot. When correctly adjusted, re-tighten the locknut counterclockwise. (Fig. 4.10)

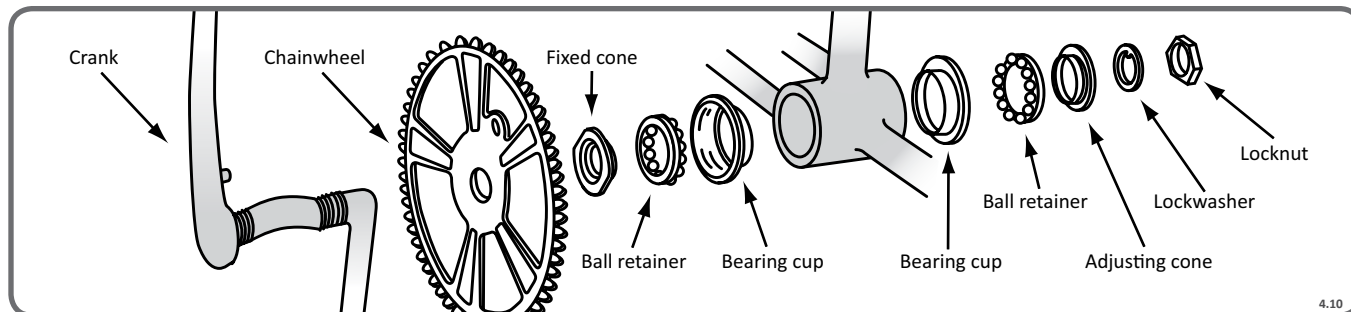

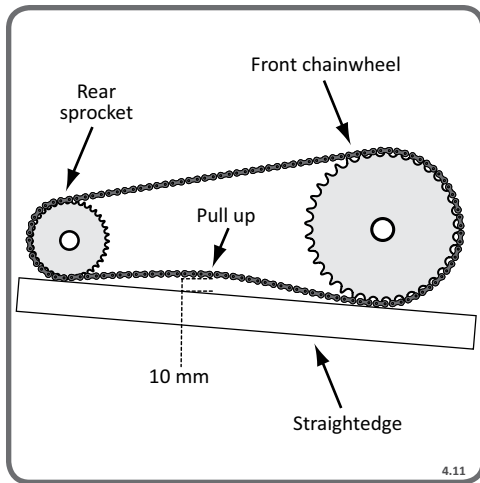

To disassemble:

1. Remove the chain from the chainwheel.
2. Remove the left pedal by turning the spindle clockwise.
3. Remove the left side locknut by turning it clockwise and remove the keyed lockwasher.
4. Remove the adjusting cone by turning it clockwise with a screwdriver.
5. Remove the left ball retainer, slide the crank assembly out of the frame to the right, and remove the right ball retainer. Clean and inspect all bearing surfaces and ball retainers, and replace any damaged parts. Pack the ball bearing retainers with grease, then re-assemble in the reverse of the above procedure.

Lubrication and Adjustment - 3 piece cranks

3 piece crank designs can vary. Please see a qualified bicycle mechanic for any 3 piece crank adjustments or repairs. Or refer to a detailed bicycle repair manual for further information. Several specialized tools are needed for disassembly and maintenance of 3 piece cranks. Do not attempt service without access to the proper tools.

Chain



Do not ride with a damaged chain.

The chain must be kept clean, rust free and frequently lubricated in order to extend its life as long as possible. It will require replacement if it stretches, breaks, or causes inefficient gear shifting. Make sure that there are no stiff links, they must all move freely.

Rear Sprocket Front Chainwheel (Fig. 4.11)

For single speed bicycles, ensure that chain tension is correct. Follow the test in (Fig.4.11). If the chain can be moved more than 10mm, the rear wheel should be moved back until proper chain tension is achieved.

- Pull up
- 10 mm
- Straightedge

Lubrication

The chain should be lubricated with light oil at least every month, or after use in wet, muddy, or dusty conditions. Take care to wipe off excess oil, and not to get oil on the tires or rim braking surfaces.

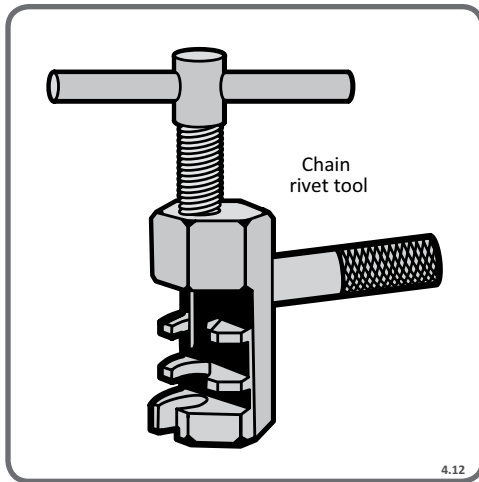

Adjustment and replacement

On derailleur geared bicycles the rear derailleur automatically tensions the chain. To adjust the chain on single speed freewheel, coaster hub braked or 3-speed hub geared bicycles:

1. Loosen the rear axle nuts (and coaster brake arm clip if fitted) and move the wheel forward to loosen, or backward to tighten, in the frame.
2. When correctly adjusted, the chain should have approximately 10mm of vertical movement when checked in the center between the chainwheel and rear sprocket. Center the wheel in the frame and re-tighten the axle nuts after any adjustment. Bicycles which have a single speed freewheel, coaster hub brake or 3-speed hub, generally use a wider type chain than derailleur geared bicycles. These chains can be disconnected by way of a special U-shape joining link, that can be pried off the master link with a screwdriver. To replace, feed the chain around the chainwheel and rear sprocket, fit the master link into the rollers into each end of the chain, position the master link side plate, and slip on the U-shaped snap-on plate. Make sure the open end of the U-shaped plate is trailing as the link approaches the chainwheel when pedaling forward.

Derailleur geared bicycles use narrower chains and require a special tool to fit and remove chain links, or to change the length. To remove, fit the rivet tool so that the punch pin is centered over any one of the chain rivets. Push the rivet almost all the way out, then back out the punch and remove the tool. Holding the chain on both sides of the punched rivet, bend it slightly to release link from the rivet. To install, feed chain around chainwheel, rear sprocket and derailleur cage with rivet facing away from the bicycle. Bring the two ends together within the chain rivet tool and punch the rivet into place. Be sure not to push rivet too far through side plate. (Fig. 4.12)

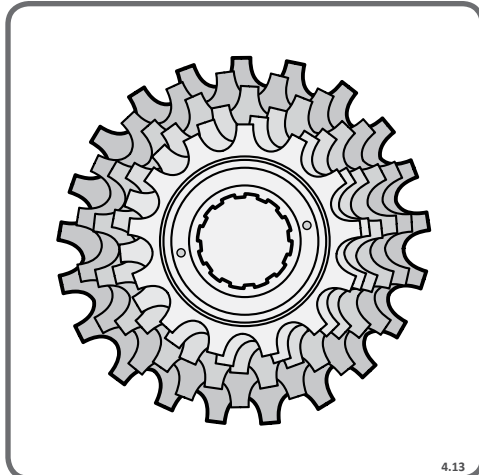

Freewheel

Like the chain, the freewheel must be kept clean and well lubricated. If the chain has become worn and needs replacing, then it is likely that the freewheel will also have become worn and should also be replaced. Take the chain off the freewheel and rotate it with your hand. If you hear a grinding noise or the freewheel stops suddenly after spinning it, it may need adjustment or replacement. Such action is beyond the scope of this manual and you should consult a specialist. (Fig. 4.13)

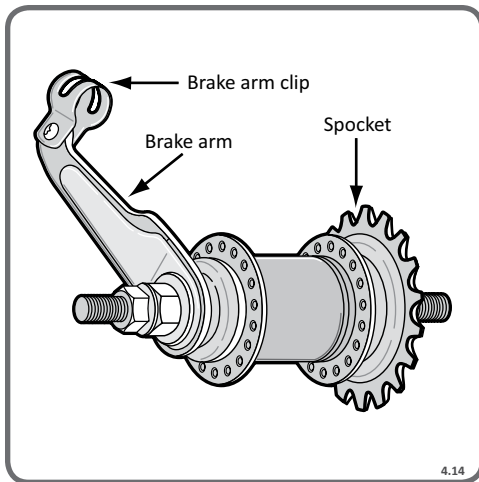

Lubrication

Remove any accumulated dirt from the freewheel with a brush and a degreaser. Disassembly of the freewheel is a complicated procedure requiring special tools, and should be left to a specialist. Apply oil to the freewheel whenever you lubricate the chain, taking care to wipe off any excess.

Coaster Brake Hub

Many BMX style and other children's bicycles are fitted with a coaster hub brake in the rear wheel. This type of brake offers the advantages of reliability and easy operation. The brake is operated by applying back pedal pressure and allows the rider to 'coast' without pedaling, if desired. There are several models of coaster hubs available, and the internal mechanisms are very complex. They require infrequent attention as far as lubrication, adjustment or replacement of internal parts; if needed, this should be left to a specialist.

Keep the coaster hub sprocket clean and oil it along with the chain.

Make sure the brake arm is correctly attached to the chainstay with the brake arm clip. The brake will not operate otherwise. (Fig. 4.14)

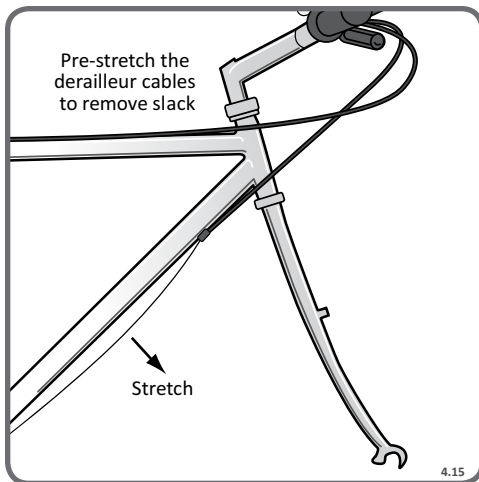

Derailleur Systems

The derailleur system includes the front and rear derailleurs, the shift levers, and the derailleur control cables, all of which must function correctly for smooth gear shifting to occur. There are several different types of derailleur systems but all operate using similar principles. For the rear shifter, there will be a positive "click" for each gear. When properly adjusted, one click should change one gear at a time. For the front shifter (if equipped) some shifters are a "friction" system, where you move the shifter until the desired shift occurs. Others have the same audible "click" to indicate that one gear has been changed. The adjustments are similar.

Inspection

The operation of the derailleur system should be checked at least every month. Check the operation of the rear derailleur first, then the front. The rear derailleur should shift the chain cleanly from one cog to the next without hesitation. Each notched position in the shifter must equate to a new gear position. After shifting, the rear derailleur should not rub on the chain. The derailleur should never cause the chain to fall off the inner or outer freewheel cogs.

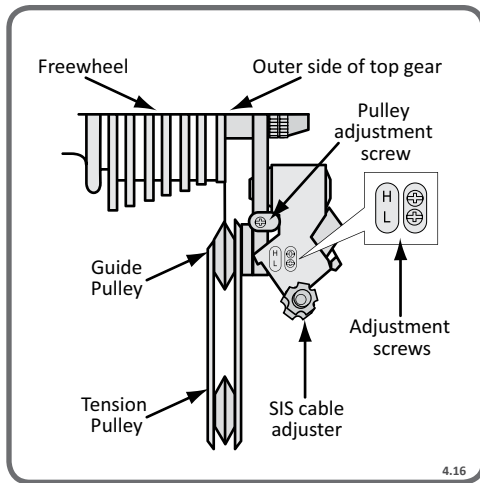

The front derailleur should also shift the chain cleanly and without hesitation between each chainring. If your bicycle is equipped with front indexing (a click between gears), then each click or stop in the shifter should equate exactly to a new gear position. When the chain has been positioned onto a new chainring, it should not rub on the front derailleur. The chain should not fall off a chainring at any time. Derailleur control cables are a critical component that must be well maintained for accurate shifting performance. Check them for any sign of rust, fraying, kinks, broken strands and any damage to the cable housing. If you find any problems, the cables may need replacing before you ride. (Fig. 4.15 - see previous page)

Lubrication

All the pivoting points of the front and rear derailleur should be lubricated with light oil at least every six months. (more often in severely rainy or muddy conditions) Be sure to wipe off any excess oil to prevent attraction of dirt into the mechanisms. The shifting cables should be cleaned and re-coated with a thin layer of grease every six months, or whenever new cables are being installed.

Adjustment - Rear Derailleur (Fig. 4.16, 4.17)

The low limit screw determines how far the rear derailleur will travel toward the wheel of the bicycle, while the High limit screw determines how far the cage will travel toward the frame.

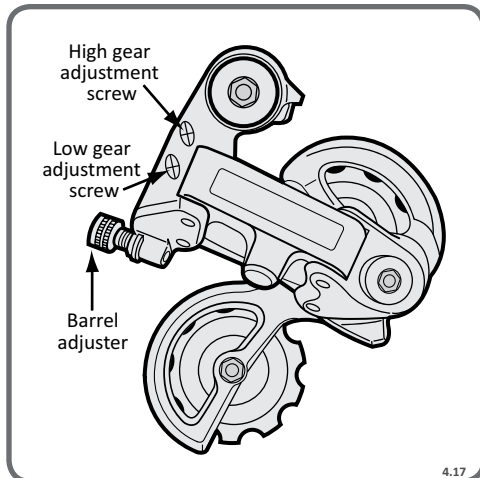

1. Shift the rear shifter to the largest number indicated, disconnect the rear derailleur cable from the cable anchor bolt and place the chain on the smallest sprocket.
2. Adjust the High limit screw so the chain and the smallest sprocket are lined up vertically. Remove any slack in the cable by pulling it taut, then re-connect the cable and tighten the cable anchor bolt securely.
3. Shift up through the gears making sure that each gear is achieved quietly and without hesitation. If noise occurs, use the barrel adjuster to fine-tune the cable tension. Turning the barrel adjuster clockwise will decrease cable tension and allow the derailleur cage to move farther away from the bicycle in small increments. Turning counter-clockwise will increase cable tension and bring the cage closer to the bicycle. This will micro-adjust the positioning of the derailleur cage in relation to the freewheel. Simply put; turn the barrel adjuster the direction you want the chain to go.

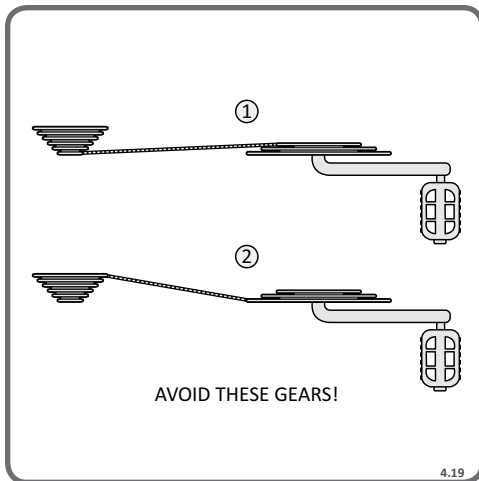
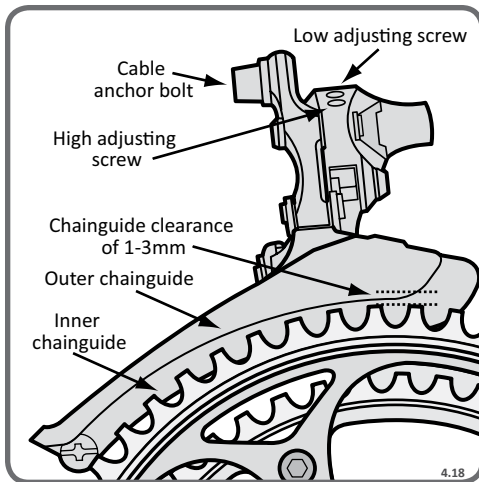

4. Shift the chain onto the largest sprocket; adjust the low limit screw so the chain and the largest cog are lined up vertically. If you are unable to get the chain to the largest cog, turning the Low limit screw counter-clockwise will enable the chain to move towards the wheel.

5. Shift through the gears ensuring each gear is achieved quietly and without hesitation. **NOTE:** It may take several adjustments to achieve the desired positioning. Please refer to the troubleshooting section for more assistance.

Adjustment - Front Derailleur (Fig. 4.18)

1. Shift the rear shifter to the smallest number indicated, then shift the front shifter to the smallest number indicated. Disconnect the front derailleur cable from the cable anchor bolt and place the chain on the smallest chainwheel.

2. Make sure the front derailleur cage is parallel with the outer chainwheel on the crankset. There must be a 1-3mm gap between the bottom of the derailleur cage and the top of the outer chainwheel teeth to ensure the derailleur will clear the chainwheel when shifting.

3. Adjust the low limit screw so the chain is centered in the middle of derailleur cage. Pull all slack out of the cable by pulling it taut, then reconnect the cable and tighten the cable anchor bolt securely.

4. Shift the front shifter into the largest gear and pedal the bike so the chain jumps to the largest chainwheel. If the chain does not shift onto the largest chainwheel, you will need to turn the High limit screw counter-clockwise until the chain moves to the largest chainwheel. If the chain falls into the pedals, the High limit screw has been turned too far. You will need to readjust the High screw clockwise in 1/4 turn increments until the chain no longer falls off.

5. Shift through each gear ensuring all are achieved quietly and without hesitation.

6. The barrel adjuster for the front derailleur is located on the shift mechanism. Turning clockwise will decrease cable tension and allow the front derailleur cage to move away from the bike, while turning counter-clockwise will increase tension and bring the cage closer to the bike. If you are experiencing problems shifting between gears, use the barrel adjuster to fine-tune the cable tension. **NOTE:** It may take several adjustments to achieve the desired positioning.

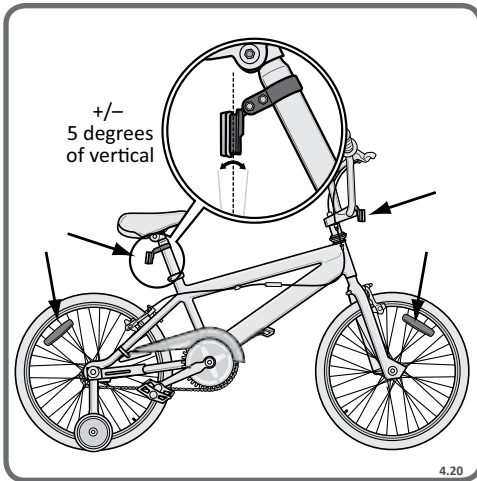

Quick Release Levers

It is important to check the quick release levers before every ride to ensure all connections are made properly and securely. Periodically, disassemble the mechanism from the bicycle and inspect for any wear or damage and replace if necessary. When reinstalling, it is very important to ensure the connections are made properly. (Please refer to p. 29-30 for the appropriate assembly instructions.)

Reflectors (bicycles over 16")

Your bicycle is supplied with one front (white), one rear (red), two wheel (white), and four pedal (orange) reflectors. These are an important safety and legal requirement, and should remain securely fitted and in good, clean conditions at all times. Periodically, inspect all reflectors, brackets and mounting hardware for signs of wear or damage. Replace immediately if damage is found. Front and rear reflectors should be adjusted to within 5 degrees of vertical. This is measured by looking at the bicycle from the side while it is on flat ground. If the reflectors are out of line, adjust as necessary and be sure all fasteners are tight. (Fig. 4.20, 4.21)



Problem	Possible Cause	Remedy
Gear shifts not working properly	<ul style="list-style-type: none"> • Derailleur cables sticking/ stretched/damaged • Front or rear derailleur not adjusted properly • Indexed shifting not adjusted properly 	<ul style="list-style-type: none"> • Lubricate/tighten/replace cables • Adjust derailleurs • Adjust indexing
Slipping chain	<ul style="list-style-type: none"> • Excessively worn/chipped chainring or freewheel sprocket teeth • Chain worn/stretched • Stiff link in chain • Non compatible chain/ chainring/freewheel 	<ul style="list-style-type: none"> • Replace chainring, sprockets and chain • Replace chain • Lubricate or replace link • Seek advise at a bicycle shop
Chain jumping off freewheel sprocket or chainring	<ul style="list-style-type: none"> • Chainring out of true • Chainring loose • Chainring teeth bent or broken • Rear or front derailleur side-to-side travel out adjustment • Cross chaining and shifting under load 	<ul style="list-style-type: none"> • Re-true if possible, or replace • Tighten mounting bolts • Repair or replace chainring/set • Adjust derailleur travel
Constant clicking noises when pedaling	<ul style="list-style-type: none"> • Stiff chain link • Loose pedal axle/bearing • Loose bottom bracket axle/bearings • Bent bottom bracket or pedal axle • Loose crankset 	<ul style="list-style-type: none"> • Lubricate chain/adjust chain link • Adjust bearings/axle nut • Adjust bottom bracket • Replace bottom bracket axle or pedals • Tighten crank bolts

Problem	Possible Cause	Remedy
Grinding noise when pedaling	<ul style="list-style-type: none"> • Pedal bearings too tight • Bottom bracket bearings too tight • Chain fouling derailleurs • Derailleur jockey wheels dirty/binding 	<ul style="list-style-type: none"> • Adjust bearings • Adjust bearings • Adjust chain line • Clean and lubricate jockey wheels
Freewheel does not rotate	<ul style="list-style-type: none"> • Freewheel internal pawl pins are jammed 	<ul style="list-style-type: none"> • Lubricate. If problem persists, replace freewheel
Brakes not working effectively	<ul style="list-style-type: none"> • Brake pads worn down • Brake pads/rim greasy, wet or dirty • Brake cables are binding/stretched/damaged • Brake levers are binding • Brakes out of adjustment 	<ul style="list-style-type: none"> • Replace brake pads • Clean pads and rim • Clean/adjust/replace cables • Adjust brake levers • Center brakes
When applying the brakes they squeal/squeak	<ul style="list-style-type: none"> • Brake pads worn down • Brake pads toe-in incorrect • Brake pads/rim dirty or wet • Brake arms loose 	<ul style="list-style-type: none"> • Replace pads • Correct pads toe-in • Clean pads and rim • Tighten mounting bolts
Knocking or shuddering when applying brakes	<ul style="list-style-type: none"> • Bulge in the rim or rim out of true • Brake mounting bolts loose • Brakes out of adjustment • Fork loose in head tube 	<ul style="list-style-type: none"> • True wheel or take to a bike shop for repair • Tighten bolts • Center brakes and/or adjust brake pads toe-in • Tighten headset

Problem	Possible Cause	Remedy
Wobbling wheel	<ul style="list-style-type: none"> • Axle broken • Wheel out of true • Hub comes loose • Headset binding • Hub bearings collapsed • QR mechanism loose 	<ul style="list-style-type: none"> • Replace axle • True wheel • Adjust hub bearings • Adjust headset • Replace bearings • Adjust QR mechanism
Steering not accurate	<ul style="list-style-type: none"> • Wheels not aligned in frame • Headset loose or binding • Front forks or frame bent 	<ul style="list-style-type: none"> • Align wheels correctly • Adjust/tighten headset • Take bike to a bike shop for possible frame realignment
Frequent punctures	<ul style="list-style-type: none"> • Inner tube old or faulty • Tire tread/casing worn • Tire unsuited to rim • Tire not checked after previous puncture • Tire pressure too low • Spoke protruding into rim 	<ul style="list-style-type: none"> • Replace inner tube • Replace tire • Replace with correct tire • Remove sharp object embedded in tire • Correct tire pressure • File down spoke

4

PURCHASE RECORD

Fill in immediately and retain as a record of your purchase.

*Please retain your sales receipt for any possible warranty claims.

Your Name: _____

Address: _____

Date Purchased: _____ Place of Purchase: _____

Model & Brand Information: _____

Wheel Size: _____ Color: _____

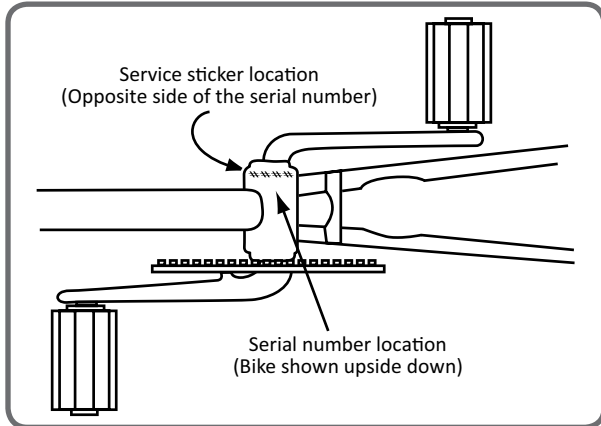

Serial Number: _____

Model #: _____

Date Code: _____

LIMITED WARRANTY AND POLICY ON REPLACEMENT PROCEDURES & RESPONSIBILITIES

Your purchase includes the following warranty which is in lieu of all other express warranties. This warranty is extended only to the initial consumer purchaser. No warranty registration is required. This warranty gives you specific legal rights and you may have other rights which vary from state to state.

FRAME

Steel frames are guaranteed against faulty materials and workmanship for as long as the initial consumer purchaser has the bicycle, subject to the condition of the warranty listed below. Aluminum and dual suspension frames are guaranteed against manufacturing defects for a period of 5 years. If frame failure should occur due to faulty materials or workmanship during the guarantee period, the frame will be replaced. For frame replacement under this Limited Warranty, contact us, stating the nature of the failure, model number, date received and the name of the store from which the bike was received, at the address given on this page. Frame must be returned for inspection at customer's expense. Please note: the fork is not part of the frame. A lifetime warranty on your frame does not guarantee that the product will last forever. The length of the useful life cycle will vary depending on the type of bike, riding conditions and care the bicycle receives. Competition, jumping, downhill racing, trick riding, trial riding, riding in severe conditions or climates, riding with heavy loads or any other non-standard use can substantially shorten the useful product life cycle. Any one or a combination of these conditions may result in an unpredictable failure that is not covered by this warranty. All bicycles and frame sets should be periodically checked by an authorized dealer for indications of potential problems, inappropriate use or abuse. These are important safety checks and are very important to help prevent accidents, bodily injury to the rider and shortened useful product life cycle.

PARTS

All other parts of the unit except Normal Wear Parts are warranted against defective materials and workmanship for a period of 1 year from the date of purchase by the initial consumer purchaser, subject to the Terms and Conditions of the warranty listed below. If failure of any part should occur due to faulty materials or workmanship during the warranty period, the part will be replaced. All warranty claims must be submitted to the address below and must be shipped prepaid and accompanied by proof of purchase. Any other warranty claims not included in this statement are void. This especially includes installation, assembly, and disassembly costs. This warranty does not cover paint damage, rust, or any modifications made to the bicycle. Normal Wear Parts are defined as grips, tires, tubes, cables, brake shoes and saddle covering. These parts are warranted to be free from defects in material and workmanship as delivered with the product. Any claim for repair or replacement of Normal Wear Parts (grips, tubes, cables, brake shoes and saddle covering) and missing parts must be made within thirty (30) days of the date of purchase. The warranty does not cover normal wear and tear, improper assembly or maintenance, or installation of parts or accessories not originally intended or compatible with the bicycle as sold. The warranty does not apply to damage or failure due to accident, abuse, misuse, neglect, or theft. Claims involving these issues will not be honored.

CONDITIONS OF WARRANTY

1. Your bicycle has been designed for general transportation and recreational use, but has not been designed to withstand abuse associated with stunting and jumping. This warranty ceases when you rent, sell, or give away the bicycle, ride with more than one person, or use the bicycle for stunting or jumping.
2. This warranty does not cover ordinary wear and tear or anything you break accidentally or deliberately.
3. It is the responsibility of the individual consumer purchaser to assure that all parts included in the factory-sealed carton are properly installed, all functional parts are initially adjusted properly, and subsequent normal maintenance services and adjustments necessary to keep the bicycle in good operating condition are properly made. This warranty does not apply to damage due to improper installation of parts or failure to properly maintain or adjust the bicycle. NOTICE: Bicycle specifications subject to change without notice.

CYCLING SPORTS GROUP™

16 Trowbridge Drive
Bethel, CT 06801 USA
Retailer Service: 1-800-843-2453
www.schwinnbikes.com