

IRAJ BASHIRI

**'TO BE' AS THE ORIGIN OF
SYNTAX: A *Persian Framework***



Bibliotheca Islamica

'To Be' as the Origin of Syntax
A Persian Framework

IRAJ BASHIRI

**'TO BE' AS THE ORIGIN
OF SYNTAX**

A Persian Framework



BIBLIOTHECA ISLAMICA

Minneapolis

1973

Copyright © 1973 by Iraj Bashiri
Manufactured in the United States of America

Library of Congress Catalog Card Number: 73-77846
International Standard Book Number: 0-88297-003-8

BIBLIOTHECA ISLAMICA / Booksellers & Publishers
Box 14174 University Station
Minneapolis, Minnesota 55414 / U.S.A.

For My Parents

Muhammad and Rabab Bashiri

ACKNOWLEDGEMENTS

Many people have contributed to the making of this book. Although I am grateful to all of them, to the individuals mentioned below I am especially indebted.

I am indebted to Professor Gernot L. Windfuhr most of all as he initiated me in the field of Iranian linguistics and spent countless hours discussing theoretical justifications with me and, in the process, helped me bring my disparate concepts into focus. I am also indebted to Professors Robbins Burling, Peter Fodale, Kenneth C. Hill, Harold V. King, Kenneth L. Pike, Donald L. Stilo and Paul Thieme for my orientation in the field of general linguistics. Furthermore, I am grateful to Professors Robert L. Kyes, Kenneth A. Luther, Ernest N. McCarus and Herbert H. Paper for reading an earlier draft of this study and for their insightful comments in their relevant fields. It is only fair to say not all of them agree with my views and I am the sole person responsible for the assertions in this book.

For administrative assistance I am grateful to Mrs. Carolyn J. Cowan; and for publication assistance to the staff of Bibliotheca Islamica. The typing of this book, in many forms, has been done by my wife Carol. My debt to her and my daughter Marian is truly great.

The publication of this book is partially supported by the Center for Near Eastern and North African Studies of The University of Michigan. I would like to thank Dr. Luther and the remaining members of the Executive Committee on Near Eastern and North African Studies of that University for their support.

PREFACE

This book, a revised version of my 1972 University of Michigan dissertation, suggests and describes the further development of case grammar in the context of a general theory of syntax. The linguistic material is taken from Persian; however, the suggested framework is not confined to Persian, but appears to be generally applicable.

The problem that elicited this framework was the inadequacy of verb-classification in the available theories of syntax, and related to it the interrelationship of the cases. Moreover, on the verbal side, so far there are suggested only vague assumptions as to the correspondence between case and the respective verb level. A further, much more crucial point, is the insufficiency of general semantic differentiation between abstract and functional levels.

Following Fillmore's suggestion for a hierarchy [Fillmore 1971], this framework posits and defines a hierarchy of six basic cases. As a major development of that, the nominal hierarchy is systematically correlated with a corresponding verb level hierarchy.

Chomsky was one of the first to suggest a semantic differentiation between abstract and functional levels to account for the different surface regularities or irregularities for the verbs especially be, seem, and have [Chomsky 1957]. Developing this insight was necessary to distinguish between not only two but three levels: functional, abstract and 'mixed', where abstract is confined to the verb 'be', while 'mixed' includes verbs which operate on both abstract and function levels. These levels can be looked at

as interrelated by transformation processes, e.g.

Function :	u sup-ra særd kærd	
		he cooled the soup \implies
'Mixed' :	sup særd šod	
		the soup cooled \implies
Abstract :	sup særd æst	
		the soup is cool

This corresponds exactly to sentence types cited by Lakoff [Lakoff 1970].

John cooled the soup.

The soup cooled.

The soup is cool.

The most essential and innovative suggestion of this framework, following insights of modern and medieval philosophers of language, is the derivation of sentences, not from #S#, but from the universal verb budæn 'be' of which the conceptualized linguistic primitives VBU (conceptualized verb) and NBU (conceptualized noun) are generated. The hierarchy of cases and verb levels generated through these primitives and the selected problem of the so-called 'compound verbs' in Persian constitute the final chapters of this work.

CONTENTS

Acknowledgements	vii
Preface	ix
Table of Contents	xi
List of Illustrations	xiii

Chapter One: General Backgrounds

1.1 Introduction	3
1.2 Approaches to Persian Syntax	5
1.3 State of the Theory of Syntax	17
1.4 Hikmat Philosophy and Modern Linguistics	32
Footnotes	39

Chapter Two: Assumptions and Derivations

2.1 Introduction	43
2.2 The Neutral System	44
2.3 Summary: Neutral System	54
2.4 Feature Specification System	55
2.5 Restrictions on the FSS	65
2.6 The Unified System	65
2.7 Summary of Rules	75
Footnotes	78

Chapter Three: Explanation with Examples

3.1 Introduction	81
3.2 The Hypersystem	82
3.3 Transformations within the Hypersystem	111
Footnotes	115

Chapter Four: Residual Problems

- 4.1 Introduction 119
- 4.2 Sentences Across the Levels of the
Hypersystem 120
- 4.3 Clause Expansion 132
- Footnotes 140

Chapter Five: Theoretical Conclusions

- 5.1 Introduction 142
- 5.2 Conclusions 143

Appendix A: Verb Compounding

- A.1 Introduction 147
- A.2 Approaches to Compounding in Persian 148
- Footnotes 155

Appendix B: Terminology 157

References 171

ILLUSTRATIONS

1	Syntactic Relations	37
2	The <u>budæn</u> Matrix	112
3	The Hypersystem Matrix	113
4	<u>budæn</u> and the Hypersystem	113
5	Summary Matrix	114
6	Sentence Types	120
7	Instances of Transformation Across Levels	130
8	Function Slot Identity Across Levels	131
A-1	Compounds Analyzed in Terms of Levels and Relations	154

*'To Be' as the Origin of Syntax
A Persian Framework*

Chapter One

GENERAL BACKGROUNDS

1.1 Introduction

This book is a systematic study of syntax through Persian, the standard language of Iran today. It is an attempt to formulate a coherent system of grammar developing a new theoretical approach. The latter, while essentially based on insights from modern linguistic theory, includes observations of philosophers of medieval Iran as well. My grammatical model, thus, is not written exclusively for Persian and contains much that is applicable to other languages.

This model was developed because, in my opinion, the mere application to Persian of the models provided so far were only partially successful in elucidating Persian grammar, from the 'Latin' model used by Jones in 1771 to the Fillmorian 'case' model applied by Palmer in 1970. Furthermore, my investigations in the syntax of Persian have convinced me that the result of theoretical approaches to similar linguistic problems differ depending on the linguistic media and the logistics underlying them [cf. M. R. Bateni 1969: 125-26].

Developing a new model necessitates certain restrictions. Much of my discussion focuses on essential assumptions and 'deep' or 'abstract' levels of grammar; their clarification has preference over the detailed derivations in any one part of the grammar; consequently, only certain subsystems of the grammar are developed to a stage which may be called 'fairly near' the 'surface'.

(Nevertheless, in order to back up the argument, at each crucial point of derivation, sample 'surface' realizations are added.) Thus, the following is not a 'surface' grammar of Persian in the sense of a detailed reference grammar or a textbook [cf. Bashiri 1972b, for example], but a 'deep' grammar attempting to detail the inherent general system underlying syntactic relations through explorations in Persian syntax.

The remainder of this chapter is divided into three main sections dealing with various aspects of the development of Persian in the context of the theory of syntax. The first section is a resumé of the studies so far undertaken by Iranists. This is necessary because the model which I will outline further below for syntax in general is based on Persian syntax and thus will have to assume earlier achievements as granted. The section deals with the 'history' of the development of the description of the syntax of Persian from the time of Jones' grammar, 1771, until the application of 'case' grammar to Persian, in 1970, by Palmer. To this I will relate the 'Persian' approaches to syntax in the works of Medieval Persian authorities on logic like Ibn Sina (known to the West by his Latinized name Avicenna 980-1037), and more recent modernizers like Kasravi. In the second section I will deal exclusively with the state of the contemporary theory of general linguistics concentrating on the major contributions of Chomsky, Lakoff, and Fillmore. In the last section I will give an outline of the general system that I propose for syntax and will indicate in general terms how this system can elucidate some of the current problems of generative models.

In conclusion, I will show that the ideas contributed by my predecessors, both ancient and modern, can be developed and systematized. I further will show that the essence of both ancient and modern achievements can be captured and utilized to create a unified system within which the different aspects of the theory of syntax can be accommodated.

1.2 Approaches to Persian Syntax

The course of written grammars of Persian hardly differs from that in other languages, 'exotic' or not. In spite of the existence of theoretical innovations in linguistics through the centuries, little appears to have filtered down to the writers of particular grammars. However, this statement should be modified. Written grammars largely followed the general trends in other fields of practical observations and taxonomy rather than in relying on 'mentalistic' constructs. Grammars had to be practical and usable, tools towards the finer products of its speakers, i.e. literature. It appears that similar to the practical adaptation of the descriptive structuralist methodology of our day for the description of a language and textbooks it was the 'Latin' grammar that served as a vague model for grammars and textbooks.

The essential difference between the two approaches, mentalistic-logic, 'explanatory', on the one hand, and formalistic-practical, 'descriptive', on the other, is evidenced by the verb budān 'to be' and the ways it has been handled. While treated as a 'defective' verb among others by descriptivists, and a predictable 'dummy' by generativists and case grammarians, it has been regarded as the most fundamental and nuclear 'concept' by logicians of language like Avicenna. My model justifies Avicenna's position by unifying these approaches.

1.2.1 The Prestructuralist Grammars

There is a long list of prestructuralist Persian grammars, extending from the first substantial work: A Grammar of the Persian Language (hence Persian Grammar), written by Sir William Jones, the orientalist, in 1771, up to the monumental Higher Persian Grammar presented by D. C. Phillott in 1919. [For pre-Jones studies in Persian grammar see Khoromof 1970: 85-86.]

There is not much 'history' preceding Western approaches to Persian syntax culminating in the grammar of Jones for which he began 'collecting rules' as early as

1767 [Cannon 1952 : 11]. Jones' main and possibly only reliable source was Meninski's Persian dictionary.¹ It seems that lack of previous dependable scholarship as well as lack of thorough linguistic orientation had blocked the way for Jones' full discovery of the problems of Persian. In fact, Jones' interest in the language dwelled mostly on Persian literature rather than in Persian grammar. As a 'grammarian' Jones tried to 'open the mine of Persian literature' so that 'men of taste ... will undoubtedly be pleased to unlock the stores of native genius, and to gather the flowers of unrestrained and luxuriant fancy' [Jones 1771: XXIV]. In this trend he is so persuasive that even some of our contemporary scholars regard him an authority [cf. Arberry's opinion of Jones in Cannon 1952 : 14].

In my opinion, Jones' treatise on Persian when compared to our modern, more mathematically oriented mind, is delightful, at times even nostalgic. It permits us to look at Iranian linguistics, in the West, in its earliest stages of development. At the same time it serves as living evidence for the little progress the writing of Persian grammar has made during the tumultuous years that followed Jones' grammar.

The only improvements made on Jones' Persian Grammar between 1771 and 1783 was the addition of an index by W.A.J. Richardson, and later in 1823 additional minor improvements by Samuel Lee [Cannon 1952 : 11].² Mere recurrence of the prototypes set up by Jones in some of our more modern studies on Iranian dialectology is indicative of this imitation and lack of innovation.³

Jones' grammar was not based on a model created by him for Persian. On the contrary, as mentioned above, his grammar was based on the 'Latin' grammar. The merit of Jones' grammar, however, lies in the introduction of Western practical and formalistic approaches into Persian. The significance of his adaptation of Persian to Latin rules is best seen in the nine London editions that his work went through by 1828 [Cannon 1952 : 13]. In that sense it was a universal achievement both in our modern sense of 'language universal,' and in the sense of its universal acceptance by the majority of contemporary scho-

lars in the field.

The Western practical, formal outlook later on also pushed aside the still mentalistic logic concept of grammar in Iran itself. The linguistic outlook introduced by Jones soon changed the view of grammar on which logicians and grammarians in Iran had based their studies.⁴ Jones' treatise won acclaim in Iran, as it did in Europe, because of the 'universal' force supporting it. One important facet of these was the inclusion of comparative linguistics in Jones' presentations. The native linguists were soon convinced of the superiority of Jones' approach, as they did not have rules which could handle or surpass his. They had to give in because their logically based grammars did not have the form-orientation, and thus the little descriptive power -- as we would say now -- that marked Jones' system. In their grammars they could not find universal rules that could explain the relations between languages distant both geographically and linguistically, as Sanskrit and English were. Most important of all, they were given to overlooking the essential difference, namely the fact that their studies were based on and backed by reason and logic. They no longer saw the importance of the essential statement on which they founded most of their early findings: al-insānu heyvānu-nnātiq 'man is a rational animal' (for further discussion on native grammarians see below).

As we see it today, it seems that Jones introduced a tentative grammatical model for Persian.⁵ But, in spite of its tentative aspect, it has been accepted as the gospel of truth ever since and followed by a number of authors who could merely read, write or speak Persian imperfectly. Those scholars of Orientalistics who had some background in Arabic, and were thus familiar with the script, soon seized the opportunity and introduced Arabized Western grammars as authentic grammars of Persian. The best example of this treatment of Persian is documented in The Persian Moonshee published in Calcutta in 1801. The forms that Francis Gladwin, the author, 'creates' for Persian to fit the Latin pattern, are recommended to all linguists who cannot find forms that their 'universal base

components' generate. As an example of his type of grammatical insight one ponders with perplexity on such forms as: *miguyanide bašæm [my asterisk and transliteration, Gladwin 1801 : 35].⁶

Those scholars who are familiar with the syntax of Persian know that the verb goftæn 'to say' does not have a causative form *guyanidæn, nor is there a perfective aspectual form *miguyanide, let alone an aspectual causative perfect in the subjunctive! (Such a form of the subjunctive exists, however, in modern Tajiki-Persian, although not in the causative, it seems [Windfuhr, personal communication].)

Jones' attempt, which seems to have started as an evaluation of the field and establishment of the formalistic approach, was later on, in 1919, continued by Phillott, who made the most extensive and detailed description of Persian grammar. While Jones did not go beyond the simple explanation of the workings of Persian, Phillott detailed every bit of data available to him through the works of his predecessors Platts, Ranking, Rosen, Chodzko, Haggard, Le Strange, Tisdale, Socin, Thacher, Wright and others [Phillott 1919 : iii]. He classified almost all recorded instances of Persian structures according to surface values assigned to them and presented, for the first time, a reliable reference grammar for Persian. In fact, his grammatical explanations, his classification of nominal and verbal clauses, his treatment of some aspects of the ezafe and many other aspects of Persian are still noteworthy. He also included in his study the variants of Persian in India, Afghanistan, and Tajikestan. Phillott's explications constitute a singular source for those grammatical structures of Persian that have not received the attention even of more modern linguists.

1.2.2 The Pretransformational Grammars

Application of the (American) structuralist techniques to Persian started with the work of Gertrude Elizabeth Nye at the University of Michigan. In 1955 she submitted her dissertation on Persian: The Phonemes and Morphemes

of Modern Persian, a work in the phonology and morphology of Persian still worthy of note. The solutions she had offered for these two levels of Persian constitute the solid base for any further study in the structures of Persian.

Soon after, Gilbert Lazard published his Grammaire du Persan Contemporain, which dealt with Persian phonology, morphology and syntax. This work clearly underscored the importance of the distinction between the colloquial and the formal aspects of Persian originally set forth by Nye [cf. also Paper 1959]. Lazard's work was followed in 1958 by the insightful survey of essential problems of Persian morphology in Das Neupersische by Wolfgang Lentz. These works represent the state of Persian linguistics at the time of the recent revolution in general linguistics, the introduction of the generative-transformational grammar by Noam Chomsky in his Syntactic Structures [1957]. I will refer to the stage prior to this development as the pre-transformational stage.

1.2.3 Summary of Achievements

In review, the immediate pretransformational era of Persian grammar was a productive period, to a certain degree innovative. During the two decades that the field was in their hand, the structuralists questioned the validity of the solutions offered by the earlier scholars and were constantly searching for new ways to elucidate the countless problems that Persian grammar offered. Consequently, the investigations of Nye, Lazard, and Lentz proved the syntax of Persian to be more complex than was assumed earlier. The complexity of the examined structures was to the extent that these scholars could give no definite solution to any one problem lest it should border on the semantic and other complex areas with which they were not fully familiar. Their doubts are documented repeatedly, as, for example, by Lazard's words regarding the 'post-position' -ra :

L'emploi de la postposition râ n'est pas défini par des règles formelles rigoureuses. Il dépend

de conditions sémantiques et grammaticales complexes [Lazard 1957 : 175].

Indeed, it was due to the efforts of the scholars mentioned above, that many of the hidden problems of Persian were uncovered. The effect of this revolutionary period of Persian studies, namely the pretransformation stage is summed up by Paper in his review of Lazard's Grammaire:

In a field so long subject to nothing but the most traditionalistic of grammatical analysis, where so little attention has been paid to synchronic description of the language as it is actually used, where hardly a word is given over to discussion outside formal literary usage, and where students have been taught a view of Persian more appropriate to the Middle Ages than to the present, Lazard's grammar of Persian will come as a breath of fresh air [Paper 1959 : 31].

1.2.4 The Transformational and Case Theory Grammars

The pre-Aspects era of generative transformational grammars is vaguely introduced through Telegdi's Über einen Fall von struktureller Homonymie im Persischen, in which he discussed compound nouns and adjectives of the type del-tæng 'depressed', and categorized them under 'Sb. + PART. PRÄT.' as he formulates it [Telegdi 1964: 237]. His interpretation of særbaz tir xorde æst 'the soldier is shot' as the underlying form for særbaze tir xorde 'shot soldier' [my transcription and translation] and his transformational analysis of such compounds as:

$$N_1N_2VAff \longrightarrow N_1eN_2V \text{ de } [\text{Telegdi 1964: 242}]^7$$

reminds one of Chomsky's earliest approaches [cf. Chomsky 1957] of capturing the correlations between surface data and configurational nodes.⁸ It was roughly a decade later

that Chomsky reintroduced this same mechanical correlation procedure to account for a new linguistic insight: the distinction between surface and deep structure [cf. Chomsky 1965].

The discussion of the surface and deep structures continued to be a feature of Persian studies both in Persian syntax and in Iranian dialectology [e.g. Stilo 1971]. In 1970 Moyne and Palmer took up the study of the syntax of this language adopting the generative transformational and case grammar models, respectively. Due to their approaches, a basic problem for both authors was the verb budæn 'to be' and its position in their adopted frameworks. Eventually, both authors concluded that budæn is predictable and can be totally 'ruled out' of the deep structure of Persian. Thus, every such sentence generated through their systems, starts as a budæn-less deep structure realization. Then, for sentences that demand the existence of budæn they devised a series of rules that introduce this verb into the sentence as the deep structure realization is converted, i.e. 'transformed' to its surface form by application of syntactic rules.

Unless one is totally blinded by one's own theory, it should be evident that predictability on the one hand, and lack of deep structure realization on the other, are two entirely different aspects which should not be confused. It is true that in certain superficial instances one can predict an instance of budæn. It is also true that certain deletion rules can be written to regularize the surface realizations that have instances of this verb. The problem, however, does not rest at these presurface adjustments. I call these 'adjustments' to draw the reader's attention to essential differences between budæn as a surface morphological realization to be justified in terms of deep-surface correlation rules versus budæn 'Be' as a deep structure essence underlying linguistic projection. The important questions are among others: to find a systematic way to account for abstract constructions at the base of which we find transformed forms of budæn; to find appropriate rules to handle the passive without introducing budæn as a fictive superstructure over the whole deriva-

tion; to solve the question of recursiveness through budæn without adding a recursive element to the base component.

1.2.4.1 budæn, a Problem for Generative Models

In conclusion, the prestructuralists and the pretransformationalists solved the problem of 'to be' by presenting long lists of surface irregularities all of which were accommodated nicely in contrasting paradigms. This was followed by the work of the early transformationalists who singled out this verb as a special verb type to be classified as a Stative verb distinct, for example, from the verbs which were 'transitive', 'intransitive', etc. More recent transformationalists have ruled this verb totally out of the deep structure and introduced it by rules.

In spite of this long 'history' both in the theoretical literature and in the literature on Persian grammars, budæn 'to be' has remained a decisive, unsolved problem in the syntax of Persian and so has the problem in general linguistics. I have to stress the following: if recently the necessity for the immediate introduction of symbolic logic into linguistic studies had not become imperative, and if there were no evident indications of a merger between the ontological studies of Medieval Iranian (and other) logicians and the most recent theories of linguistics (for further discussion see part 1.4 of this chapter), the budæn problem would not have surfaced as a crucial problem and consequently would not be chosen to define the syntactic base component of this grammar achieved through Persian.

1.2.5 Native Approaches to Persian Syntax

1.2.5.1 Iranian's Use of Native Models

Very little research has been done in the areas of native approach to Persian syntax.⁹ Indeed, in recent studies there is no mention of the logicians who used language as the basis for logical discussions. As a matter of fact, one could dare the statement: in contradistinction to the approach of the Western scholars who use logic to arrive

at linguistic systems, Eastern scholars use language (to them a physical realization of logical relations) to arrive at desired logical abstract deductions.

One might ask then, why have such eminent scholars as Al-Farabi, Ibn Sina, Suhravardi, Mulla Sadra and finally the nineteenth century thinker Sabzavari -- why have they been so easily ignored? The answer lies probably in the area of the dominance of a certain field of learning over another. Their dominating fields were Islamic religious studies. For the scholars mentioned above the ultimate objective was theosophy rather than either philosophy or logic. This dedication to theosophy, however, did presuppose careful search for better treatment of logic and consequently grammar, since better grammar offered better logic and better logic resulted in better solutions for their theological problems. The researchers were considered men of God and dedicated to finding ways to reach the Ultimate. They considered themselves neither pure grammarians nor logicians.

Because of the lack of research and consequently lack of appropriate recognition of these scholars, the discussions about them generally result in a superficial, simplistic view. For example, concerning the development of Persian grammars Felix Tauer remarks:

It is indeed remarkable that although it was the Persian Sībavayhi who created the Arabic system of grammar and that later on important works on this subject flowed from the pens of learned men of Persian origin, the Iranians left the field of the grammatical treatment of their own language almost untouched. It cannot of course be denied that the extremely simple grammatical structure of Persian contributed to this and that an impressive system could not be developed on the basis of Aristotelean dialectics, as was possible in Arabic, and that it was just these facts that forced Persian philologists to turn their attention to other

branches of their subject, namely to lexicography, the theory of style, poetics and epistolography, which they studied far more zealously than did the Arabs. In the preface or epilogue to their dictionaries the philologists thus usually found an opportunity to deal shortly with the grammatical rules of Persian, the arrangement of which is certainly very confused and the conception often seemingly very odd, and this they apparently considered to be sufficient.

Independent works on grammar are limited to small treatises of a few pages on single grammatical problems and here too the lexical tendency is more evident. It is only in the second half of the 18th century that a Persian grammar appears, viz. the *Mīzān-i fārsī*, 'The Scales of Persian,' by Jamālu'd-dīn husayn b. Nūru' Hāh al Marḡashī ash-Shushtarī and the *Qavā'id-i fārsī*, ... [Tauer 1968: 429; cf. also Lazard 1970: 64-67].

Tauer's assertions are not quite justified. The first recorded grammatical treatise of Persian dates, at least, from the time of Ibn Sina (980-1037) if not earlier. I am referring to the grammar presented by the Sheykh in his danešnameye 'alā'i 'the 'Alā'i Encyclopædia'. Regarding Ibn Sina, S. H. Nasr remarked:

At the age of ten he already knew grammar, literature and theology as well as the whole of the Quran [S.H. Nasr 1964: 177].

In modern terms most of the research by Islamic Iranian scholars was done within the boundary of the universal logic 'deep structure', irrespective of language specific applications. If they happen to mostly cite examples in Arabic, it is because Arabic was the scholarly language

of the Islamic world of the time.¹⁰ It was by necessity that scholars, and those for whom they worked, used the Arabic language for the purpose of communication. In Khunsari's words and my translation:

بحث منطقیان در باره الفاظ بحثی بسیار کلی
 است باین نحو که در همه زبانها صادق است
 بخلاف بحث علمای دستور که مباحث آنها غالباً در
 زبانی معین صدق میکند . . . یعنی بر فیلسوف
 منطقی لازم است که لفظ را بطور مطلق مورد نظر
 و توجه قرار دهد (نه بنحوی که مقید و مختص
 بزبانی معین باشد) . چه هنگام افاده و استفاده
 لفظی که شارح مقصود باشد لازم است .

[Khunsari 1959: 55-56].

The logicians' discussion of 'words' is highly general, so that it can fit any language. This is in contradistinction to the view of the grammarians whose discussions mostly fit given languages . . . that is to say, the logician has to consider 'words' in their abstract sense (namely, not bound to specific languages); because for the purpose of creation and usage one needs 'vehicles' that transfer the meaning.

One might mention here a later epigone of classical Islamic linguistics, S. A. Kasravi.¹¹ At the beginning of the 1930's Kasravi made an attempt to reintroduce some of the concepts discussed above into the linguistic discussions of that time. But due to religious bias and conflicts of opinion among the scholars who were involved in the purification movement in Iran, his efforts were not successful [Kasravi 1955]. The extension of the logic-based grammars which give precedence to 'meaning', however, are documented in M. Khunsari's work qævanin-e mæn-

teq-e suri 'Rules of Symbolic Logic' published in Tehran in 1959.

1.2.5.2 Iranian's Use of Western Models

Western models have been adopted by native Iranian grammarians as early as the introduction of the Latin model of Jones. In fact, the current linguistic literature in Persian used to invariably follow the traditional approach [Lazard 1970: 68]. Recently, however, the native application of modern approaches has filtered down and articles dealing with aspects of Persian grammar with regard to elementary phonological/morphological distinctions have appeared. These, although still at the mercy of traditional Iranian 'nomenclature' academics seem to have opened a new way and promise a more positive approach to the field. It will, however, be a long time before this Persian-specific analysis trend is expanded to cover the vast atlas of Iranian.

The initial attempt to divert the course of current native linguistic literature toward a more Western outlook is documented in a University of Tehran dissertation submitted in 1968 by Mohammad Reza Bateni. In it, the English variety of modern linguistics (the Neo-Firthian, or as it is often referred to, the Halliday model) is diligently applied to Persian structures. Unfortunately, the Scale and Category model [for information on this see Crystal 1971] used in towsif-e saxteman-e dæsturi-e zæban-e farsi bær bonyad-e yek næzæriye-e 'omumi-e zæban 'Grammatical Structure of Persian Based on a General Linguistic Theory' [my transcription and translation] is currently abandoned by its original propounder Halliday himself who seems now to be tending more towards American models [cf. also Ali Ashraf Sadeghi's review of Bateni--basically a content paraphrase].

1.2.6 Russian Contribution

The fact that the bulk of the literature on Persian linguistics is produced by Russian scholars is undeniable.

This should not come as a surprise. The Persian language has served as the instrument of culture and government in a large portion of Asia beyond the limits of the Iranian plateau [Lazard 1970: 65]. A considerable segment of this cultural/linguistic milieu is now within the political domain and influence of the U. S. S. R.

Regarding recent scholarship on the syntax of Persian one can mention the works of Mahmudov [1955, 1956, 1964], Šafâi [1953], Arzumanjan [1965], Abdusamatava [1964], and Rustamova [1964b]. The syntax of subordination of sentence compounding are discussed by Kamenskij [1945], Šafâi [1955, 1966, 1967], Šarova [1964] Kuxtin [1961], and Rubinčik. [For bibliography and somewhat detailed description of Russian scholarship in Iranian linguistics see Lazard 1970; see also Windfuhr forthcoming].

It should be mentioned, nonetheless, that although the bulk of Russian linguistic literature on Persian is considerable, like the native Persian linguistic literature on the subject, it follows the traditional approaches. Moreover, the Russian concern with theory, it seems, is one of application of already existing (e. g. continental European and American) techniques, rather than one of breaking new grounds.

1.3 State of the Theory of Syntax

1.3.1 Chomsky and Transformational Grammars

Generative-transformational grammars which use configurational categories (NP, VP, etc.) evolved out of the assumptions and derivations set forth by Noam Chomsky [Chomsky 1957]. In his revolutionary Syntactic Structures, he presented a phrase structure model based on observable 'immediate constituent analysis' [Chomsky 1957: 29], and backed it up with a series of optional and obligatory transformational rules [Chomsky 1957: 44]. He further introduced a recursive symbol Z of which he says '[it] is not contained in the sentences of this language' (meaning any language under discussion). This recursive indicator Z is the essential fact about phrase structure which gives

it its 'abstract' character [Chomsky 1957: 31].

Chomsky further observed that grammar is a 'self-contained' study independent of semantics [Chomsky 1957: 17], and suggested that 'fairly abstract linguistic levels as phrase structure and transformation structure are required for the description of natural languages' [Chomsky 1957: 106]. A simplified example in Chomsky's model is produced by Crystal who analyzes the sentence: The boy saw the girl.

Sentence(S) \rightarrow Noun Phrase(NP) + Verb Phrase(VP)

VP \rightarrow Verb + NP

NP \rightarrow T + Noun (N)

T \rightarrow *the* ...

N \rightarrow *boy, girl* ...

V \rightarrow *saw* ... [for this and a more detailed description of the basic points of Chomsky see Crystal 1971].

Concerning the abstract levels of grammar Chomsky has illuminating insights:

An automatic consequence of the attempt to construct the simplest grammar for English in terms of the abstract levels developed in linguistic theory we find that the apparently irregular behavior of certain words (e.g. "have", "be", "seem") is really a case of higher level regularity [Chomsky 1957: 107].

Furthermore, as early as his Syntactic Structures Chomsky discusses the important notion of 'structural meaning' as opposed to 'lexical meaning'.

The notion of "structural meaning" as opposed to "lexical meaning", however, appears to be quite suspect, and it is questionable that the grammatical devices available in language are used con-

sistently enough so that meaning can be assigned to them directly. Nevertheless, we do find many important correlations, quite naturally, between syntactic structure and meaning; or, to put it differently, we find that the grammatical devices are used quite systematically. These correlations could form part of the subject matter for a more general theory of language concerned with syntax and semantics and their points of connection [Chomsky 1957: 108].

We know that the insights offered by Chomsky in his 1957 publication had not yet matured; consequently the students of Chomsky tried to disprove him by giving counter examples to his suggestions and by presenting random observations and sporadic contradictions.¹² Eventually, Lakoff suggested the need for reconsidering Chomsky's views. This suggestion appeared in his 1965 dissertation which basically dealt with the nature of irregularities in syntax. In his dissertation Lakoff used the same concepts that were introduced by Chomsky as instances of 'higher level regularity' [Chomsky 1957: 107], as evidence for syntactic irregularity [Lakoff 1970].

Chomsky's unisurface approach to grammar was further modified by Chomsky himself to include the ideal speaker-hearer 'competence' and 'performance', later described as 'deep' and 'surface' structures [Chomsky 1965]. This new dimension became the focus of attention for the succeeding generativists who were for the first time facing the problem of semantics--a problem they had tried so hard to suppress. When faced with the problem Chomsky revised his solution offered in Syntactic Structures by adding an elaborate base component, distinct from the lexical component, to his generative grammar.

Base component rules:

- (i) $S \rightarrow NP \sim \text{Predicate-Phrase}$
- (ii) $\text{Predicate-Phrase} \rightarrow \text{Aux} \sim \text{VP (Place)(Time)}$

the emphasis on the significance of grammatical transformations offered by Chomsky as partially indicated in the quotation below:

..., we can apparently define a grammatical transformation in terms of a "structure index" that is a Boolean condition of Analizibility and a sequence of elementary transformations drawn from a base set including substitutions, deletions, and adjunctions. It seems also that these form larger repeated units (for example, substitutions, deletions, erasures) and that the limitations on their application can be given by general conventions of the sort just mentioned. If this is correct, *then the formal properties of the theory of transformations become fairly clear and reasonably simple, and it may be possible to undertake abstract study of them of a sort that has not been feasible in the past* [my italics, Chomsky 1965: 147].

Chomsky's notion of transformation, as is well known, was different in Syntactic Structures from his revised and insightful notion in Aspects. While in the former he was basically dealing with surface structures (e. g. of the type of 'have + en', and moving constituents around), in the latter he devised a more general and deep structure-oriented type of transformation in which he spoke of converting postulated deep structure realizations into their corresponding surface structure.

It is assertions of this type and 'faith' in the centrality of the role of grammatical transformations that constitute the solid base for Chomsky's view of language. [For the centrality of the role of grammatical transformations see Chomsky 1965: vi].

1.3.2 Objections to Chomsky's Model

In spite of all the points that were supporting the theory set forth by Chomsky, potential shortcomings like lack of definite criteria for verb classification, incapability to handle surface-deep correlations logically as well as formally, definition of VP/NP relations in terms of grammatical abstractions and grammatical functions, lack of appropriate surface and deep structure constraints demanded a radical change in the whole format of the Chomskian generative transformational grammars. Most of the pressure, of course, was exerted from the area of semantics--an area which Chomsky literally ignored at the outset of his theory [Chomsky 1957: 15,17]. Related to this fact was the conflict between the nature of Chomsky's aim--an abstract theory for language--and his point of departure in his grammatical investigations, namely the surface structure immediate constituent analysis.

Lack of ability to handle abstract sentences and appeal for a more abstract notion of grammatical function in investigating grammatical relations is best evidenced in Chomsky's own words:

...there are cases that suggest the need for an even more abstract notion of grammatical function and grammatical relation than any that has been developed so far, in any systematic way. Consider, for example, these sentence pairs:

- (19) (i) John strikes me as pompous--I regard John as pompous
 (ii) I liked the play--the play pleased me
 (iii) John bought the book from Bill--Bill sold the book to John
 (iv) John struck Bill--Bill received a blow at the hand of John

Clearly, there is a meaning relation, approaching a variety of paraphrase, in these

cases. It is not expressible in transformational terms, as is possible, for example, in these cases:

- (20) (i) John is easy for us to please--
 it is easy for us to please John
 (ii) it was yesterday that he came--
 he came yesterday

In the case of (20), the deep structure of the paired sentences are identical in all respects relevant to semantic interpretation of the sort we are considering here, so that the transformational analysis accounts for the (cognitive) synonymy. This does not seem to be true in the case of (19), however. For example, in the case of (19i), although the deep structures would show that "pompous" modifies "John" in both sentences of the pair, they would not express the relations of the two Nouns to the Verb that are (in some unclear sense) the semantically significant ones. Thus in some sense the relation of "John" to "strike" is the same as that of "John" to "regard", and the relation of "strike" to "me" is the same as that of "regard" to "I". We have no mechanism for expressing this fact, hence, of accounting for the meaning relation, in terms of lexical features or grammatical relations of the deep structure. Consequently, it seems that beyond the notions of surface structure (such as "grammatical subject") and deep structure (such as "logical subject"), there is some still more abstract notion of "semantic function" still unexplained. Various formal devices for expressing these facts suggest themselves, but the general problem seems to me non-trivial [Chomsky 1965: 162-3].

Objections to Chomsky's proposed framework stem from at least two different sources. These sources can be identified as objections within the system, and objections outside the system. The former culminated in the radical changes suggested by Lakoff in Irregularity in Syntax, as mentioned, and others like Gruber and Perlmutter; while from outside the Chomskian system a totally different view of the linguistic act was introduced through the 'covert cases' of Fillmore in The Case for Case. Below I will deal with these two modifications and innovational aspects of the theory of syntax.

1.3.2.1 Objections Within the System

Like Chomsky, Lakoff's contribution to the understanding of the nature of syntactic structures is, beyond doubt, outstanding. Although he is not sure of 'the exact nature of transformations', Lakoff stresses the fact that 'rules must take the form of grammatical transformations' [Lakoff 1970: xii].

Among the contributions of Lakoff one can mention the concept of rule government, rejection of distinction between syntax and semantics, retention and modification of the transformational rules, and introduction of lexical feature-mapping transformations [Lakoff 1970: 53]. The treatment of the inchoative and the rejection of the distinction between adjectives and verbs by setting up a category 'Verbal' in which adjectives are distinguished by having the value [-Verb], are indicative of Lakoff's attempt at creating a coherent system within which he could handle the sporadic cases of English grammar he had dealt with in his dissertation.

George Lakoff began his study of the syntax of English by 'trying to define the notion' "exception to a transformational rule" [Lakoff 1970: ix]. For this purpose he chose Aspects of the Theory of Syntax, written by his teacher Noam Chomsky. He also accepted some of the basic and fundamental concepts introduced by Chomsky in Aspects. For example, he accepted Chomsky's view that all lexical insertion should precede all transformational rules.

When, in the course of his study, he found that certain sentences can be derived from underlying structures that more closely represented their deep structure semantic representation [Lakoff 1970: ix], he became convinced that the Chomskian views were not able to handle the problems involved without setting up certain hypothetical categories of exception. Thus, he introduced into the syntax of English the notions of 'absolute exception' and 'lexical base hypothesis'.

These innovations, which proved to be less fruitful than they were expected, served their purpose. Their introduction diverted the 'presurface deep structure' of Chomsky towards a semanto-syntactic approach to syntax. Actually, Lakoff used semantic as well as syntactic facts to recover the meaning of sentences from their deep structure. This approach also led Lakoff to the insightful notion which he currently holds, namely the notion of 'atomic predicates'. Lakoff claimed that through the notion of 'atomic predicates' the 'great profusion of category labels that had appeared in previous transformational works could be avoided and the inventory of categories reduced to a set that could have some claim to universality' [Lakoff 1970: v-xi]¹³

Concerning the interpretation of the abstract and its role in language it seems that Chomsky and Lakoff are in conflict. According to Chomsky, verbs of the type 'have', 'be', and 'seem' are attributed to higher levels of grammar where they are realized as regular verbs. Lakoff cites the realization of sentences with those forms as examples of irregularity in syntax. On the other hand, while Chomsky remains silent as to the nature of the higher level to which he attributes these 'words', Lakoff reveals a most inspiring insight into it. In McCawley's words in the Preface to Lakoff's Irregularity in Syntax:

The rejection of the claim that lexical insertion precedes all transformation (that is the rejection of a level of "deep structure" in the sense of ASPECTS) allows one to say that <BECOME> (*or whatever the basic inchoative element is called* [my

italics] is part of the meaning of ENTER and still have clauses with ENTER derived through an application of the inchoative transformation, or rather the more general transformation of "predicate raising," of which "inchoative" and "causative" are special cases. This transformation combines the predicate element of one clause and is involved in the derivation of not only inchoative and causative verbs but also such verbs as LOOK FOR (= try to find), MALINGER (= pretend to be sick), and FORGET (= cease to know) [Lakoff 1970: vi].

The main objection to Lakoff's concept of 'absolute exceptions' came from Jeffrey Gruber [Gruber 1965]. Gruber indicated that irregularities for which Lakoff had set up 'absolute exceptions' could be handled by lexical specification of posttransformational structures, where there are indications of meaning but no lexical items [see also Lakoff 1970: ix]. Lakoff has accepted Gruber's view as correct, and thus has rejected both the 'hypothetical exceptions' and the 'lexical base hypothesis' [Lakoff 1970: x].

It was mentioned earlier, that in order to expand the scope of the simple sentence Chomsky introduced a recursive symbol Z into his derivational 'history'. This symbol, which was later to be changed to an #S#, expanded the simplex sentence by accommodating embedded clauses which defined one or more of its elements within its boundaries. However, no sooner was this device introduced than the problem of semantic analysis inside and beyond the simplex came to the fore. Faced with the demands of the theory Chomsky revised his assertions and included in his grammar an elaborate base component with strict subcategorizational and selectional features into which lexical items could be inserted within and beyond the simplex #S#.

This elaborate base component and its auxiliary transformational rules, nonetheless, (see below) could not save the Chomskian theory against the correct criticism that

the rules of the base component would apply to the derivational rules of the initial simplex #S# and will not, thus, cross over to deal with all the 'elements' of the embedded sentence in the initial simplex. This inadequacy, of course, resulted in phrase markers which underlie no correct sentences of the language. Only in one case did Chomsky go beyond the simplex. This was in the case of the most pressing problem of relativization. His solution was the introduction of transformational blocking of derivational rules on the basis of identity. Namely, if, and only if, the nominal in the embedded clause had the same identity as the antecedent nominal, rules would apply; otherwise, they would be blocked. Here, too, Chomsky ignored the possibility of natural occurrence in languages of sentences that satisfy the condition yet need not undergo the transformational blocking and still be correct sentences of the language, and vice versa.

Perlmutter, who extends the scope of Aspects, suggests:

There is in natural languages ill-formed generalized phrase markers generated by the base component which cannot be categorized as such by means of the blocking transformations [Perlmutter 1971: 3].

As can easily be seen we have not as yet seen the end of the objections raised against Chomsky's framework by linguists working with his system.

1.3.2.2 Objections Outside the System

The outside objection to Chomsky's generative transformational model stemmed from the 'Case Theory' propounded by Charles Fillmore in 1968. While Chomsky and Lakoff both tackled the surface structure trying to find underlying forms that correspond to certain superficial forms, Fillmore started from the deep structure and tried to work his way towards the surface. By doing so Fillmore claimed that he could discover 'a semantically justified universal theory', and further :

If it is possible by rule ... to make these "semantic deep structures" into the surface forms of sentences, then it is likely that the syntactic deep structure of the type that has been made familiar from the work of Chomsky and his students is going to go the way of the phoneme. It is an artificial intermediate level between the empirically discoverable "semantic deep structure" and the observationally accessible surface structure, ... [Fillmore 1968: 88].

Fillmore's position as a theorist was always vague.¹⁴ Although to some of the problems he had a direct answer, to the crucial ones (see below) he had none. The merit of his work, nevertheless, was in its point of departure--the deep structure. But even there he was not consistent. More than once we find him trying to justify his position vis à vis certain superficial prepositions.¹⁵

The main contribution of his theory is indicated in its interpretation of the term 'Case'. Traditionally, case systems were attributed to highly inflected languages like Sanskrit, Latin and Greek and were, in modern terms, a matter of surface structure. Generative transformationalists did not improve on the treatment of cases and 'for the most part viewed case markers as surface structure reflexes, introduced by rules, of various kinds of deep and surface syntactic relations' [Fillmore 1968: 5]. Having assumed that *syntax is central* [Ibid.: 3] and that *covert categories are significant* [Ibid.: 3], he introduced the concept of 'covert cases' to account for what he called 'a more semantically based system of 'case' [Lambert 1969: 13].

The cases posited by Fillmore are not limited in number and are not chosen according to defined criteria. These are only two of the shortcomings of an otherwise well worked out system. I called it 'well worked out' because it can reveal a better view of the deep structure through the introduction of a semantic-syntactic approach,

than the quasi-syntactic approach of Chomsky. In Lambert's words :

Case grammar maintains a distinction between deep and surface structure (though its deep structure is more abstract than Chomsky's) and attempts to relate the two by a series of rules [Lambert 1969: 6].

Fillmore, through accepting some of Lakoff's views, for example the rejection of distinction between Adjectives and Verbs within the Verbal, dissipated many of the factors that forced Chomsky to either introduce rigid concepts (e. g. his treatment of deviation), or to ignore certain creative language processes.

A step by step discussion of the difference between the precase-theory approaches and the modifications made by Fillmore and later by Lambert can be found in Lambert [Lambert 1969: 5-14].

Fillmore later revised the concept 'Case' and replaced it with 'role' and 'argument' [Fillmore 1970]. Halliday's 'Initiator-Actor-Goal 1967', Becker and Pike's 'grammatical meaning 1967', Gruber's 'prelexical structure 1965', Lyons' 'notional grammar 1968', and McCawley's 'generative semantics 1968' also assimilate and/or approach the Fillmorian model. But even Lakoff's 'abstract syntax' does not explore the abstract in a systematic and 'revealing' way.¹⁶

In a paper delivered at the 1971 Georgetown Roundtable Conference on Language and Linguistics, Fillmore refuses certain models as 'bad' models for the 'case' theory, and in an idealistic fashion, abandons his 'lexicalistic position' for a 'uniform case structure analysis' suggesting the need for 'more indirect sorts of relations between deep and surface structures' (whatever that means).

To achieve such an ideal, he sets up the following hierarchy of cases: Agent, Experiencer, Instrument, Object, Source, Goal, Place and Time. Regarding whether he has any solution to such a conceptual set up he explains:

So far I have spoken only about certain conceptual problems associated with the effort to reconstruct a transformational grammar along the lines of a case grammar. You may have noticed that I have so far failed to give tree diagrams or any other sort of explicit symbolic representations of the structures I have been so cavalierly talking about. That failure stems not merely from a desire to save space. I simply have not found an acceptable notation for the sort of things I want to be able to represent [Fillmore 1971: 245-246].

Perhaps I should warn the reader beforehand that my setting up of hierarchically ordered Neutral and subsequent Function and Abstraction slots of the type Neutral Agent, Functional Agent, etc. should not be confused with Fillmore's 'Case' hierarchy mentioned above. In addition, I make a distinction between slots that draw on nominals for their 'existence', as opposed to those which draw on the verbals. Thus, Time and Place which are assigned the same values as his other cases by Fillmore, will be treated differently in my framework.

1.3.3 Summary of Achievements

The preceding quick survey of both the development of writing grammars of Persian and recent grammatical theory constitute the background of this study. In a way it reflects the gradual transition from a logic-'mentalistic' approach to grammar to an antithetic formalistic-'descriptive' approach, and the tendency towards a reversal evidenced by the recent grammatical theory. My framework recognizes the antithesis as a necessary step for the attempt at a synthesis of both. The merits of this framework lie in the fact that it makes a formal synthesis of the achievements of Western linguists and develops the outcome of their studies in the light of ontological studies of

Eastern scholars who were masters of philosophical and deep structure logical analyses. Furthermore, this study, unlike other linguistic theoretical frameworks, uses a linguistic media other than the English language as the testing ground for its assertions.

In review, I have shown that following Humboldt's suggestion that 'language makes infinite use of finite means' [Humboldt 1836] Chomsky set up a generative phrase structure model based on immediate constituent analysis and backed it up with a series of transformational rules.¹⁷ Chomsky also made a distinction between surface and deep structure specifying that all transformational rules follow all lexical insertion rules. To capture the recursive nature of rules, first he introduces an expandable 'dummy' symbol Z and later the concept of recursive embedding by which process a noun phrase (NP) could be complemented with an embedded sentence if there was need for one. Chomsky further asked for more abstract notions of grammatical analysis; the type in which, he said, 'words' like 'be', 'seem', and 'have' are treated at higher levels of regularity. He also foresaw that 'structural meaning' was a key concept for the interpretation of the deep structure.¹⁸

Chomsky's views were further accepted, revised and eventually rejected by Lakoff, who introduced the concept of rule government, and then by Gruber, who introduced the lexical specification of posttransformational structures.

Fillmore, who took Chomsky's concept of distinction between surface structure and deep structure, posited deep structure and thus 'covert cases' for capturing deep structure, logical relations that he claimed were underlying the linguistic phenomenon. Later, abandoning his former 'lexical' oriented analysis Fillmore has posited certain fictitious covert, nevertheless, hierarchically ordered cases and still is searching for ways to justify, and formally represent his 'ideal' system.

Both the Chomskian and the Fillmorian models make intensive use of transformational devices. Transformational rules which are basically used for the purpose of 'filtering' [Cf. Perlmutter 1971] have proved to be too powerful and need to be constrained. Thus, most of the efforts of syntax

specialists are now actually being exerted on finding alternatives to the all powerful transformational rules for constraining deep [cf. Perlmutter 1971] and surface structures. (More on the subject of constraints will follow.)

1.4 Hikmat Philosophy and Modern Linguistics

Earlier I indicated my attempt at a synthesis of the achievements of the hikmat philosophers and the current linguistic theories. What needs to be emphasized here is the fact that these scholars were analytical thinkers. In order to discover the 'mystery' of 'existence' they used the linguistic medium which is the only link that relates their abstract ('absolute' in Izutsu's terminology) world to the physical realizations of that abstract. Izutsu sums up their investigations:

Although "existence" in this way absolutely refuses by its own peculiar structure to be represented as it really is, we can and do form a concept of "existence" on a very high level of abstraction. Such a concept is achieved through a sort of purely mechanical process. Thus in ordinary life we say "x exists", "y exists", "z exists", etc. These sentences can then be transformed into nominal forms: "the existence of x", "the existence of y", "the existence of z".

This linguistic process has an ontological basis in the fact that the reality of "existence" (wujûd) in the world of actual reality is diversified into an infinity of particular "existences" (wujûdât), i. e. particular acts of existing. Each of these acts of existing is the "existence" of some particular "quiddity", the "existence" of a man, for example, or the "existence" of a table, etc. [Izutsu 1969: 35-36].

In this way the hikmat philosopher could capture a com-

mon denominator among all 'existents' in the world. This common denominator was 'existence'. Further, he made a distinction between 'quiddity' and 'existence'. The latter being an accident to the former [for details see Izutsu 1969: 1-150]

This new dimension helped the hikmat philosopher to create a series of consecutive concretization acts starting from the Abstract (their Absolute) 'existence' and ending with the Physical (their Real) 'existence'.

Again in Izutsu's words:

... Absolute further divides itself into a number of sub-stages constituting as a whole a vast hierarchical order of "existents" (mawjûd, pl. mawjûdât), the lowest stage being that of material and sensible things as we perceive them in the present world [Izutsu 1969: 8].

1.4.1 Logic-based Ontological Studies as a Base for a Linguistic System

In essence, the goal of the modern linguistic theory is hardly different from the aim of hikmat philosophers so far as language analysis is concerned. In fact, the recurrence of the names of Western philosophers from Aristotle to Wittgenstein in the current linguistic literature [see e.g. Dowty 1971: 2] is indicative of this assertion. Below I will give a brief outline as to the reasons for the emergence of such a reversal.

Drawing on the achievements of the generative transformationalists and experienced by their error, the 'case' grammarians claimed that any analysis based on observable data was not, and could not be accurate. They claimed that the explanatory power needed to account for logic deductions underlying Actor-Action relations in the deep structure could not be convincingly captured by any modifications made on the Chomskian model which was by that time revised by Lakoff.

The generativists found themselves caught within a sys-

tem that had shown its limits. They were confronted, in the body of Fillmore's assertions, with the timeless, and so far undisputed concepts of the ancients--the concepts for the dismissal of which the whole notion of formalistic approach to language was devised by Chomsky. Thus, I believe it was not the Fillmoreian model that was trying to push Chomsky's assertions in Syntactic Structures and Aspects out of the window, but the profound and previously neglected possibilities for language analysis which were underlying his system due to his direct use of philosophy and logic matured by the ancients. Therefore, Fillmore's use of logic and philosophy was only, in a way, an indirect, however poorly presented, answer to Chomsky's plea for a highly abstract mechanism that could capture all abstract and functional linguistic relations [Chomsky 1957: 65]. The quick survey presented below will further illustrate this point.

The 'history' of logic-based grammars goes back to the time of Aristotle and the philosophers of Classical Greek civilization. The Categories of Aristotle reflects many of the ideas of its author regarding language as a symbolic indicator of the relations between human reason--logic--and the real world [Ackrill 1963].

After Aristotle both Eastern and Western scholars have endeavored to use the 'essence' of his achievements towards a solution for the language 'mystery'. In search for a solution of this 'mystery', in the East as well as in the West, theories of language became the basis of philosophy and logic.¹⁹ These two disciplines merged. The development of this merger, in the West, was such that James Beattie [1788] refers to grammatical principles as parts of philosophy:

The principles of grammar form an important, and very curious, part of the philosophy of the human mind [quoted in Chomsky 1965: 59].

In the East, grammar formed the basis of logic, and ultimately surfaced as the refined form of philosophy called

hikmat philosophy. The grammar that served as the base of Ibn Sina's mæntiq 'Logic' is the best extant evidence that has come down to us.²⁰ In fact, all subsequent ontological studies (perhaps the highest achievement of hikmat philosophy) based their arguments on linguistic evidence.

While Western philosophical studies stemming from the Aristotelian origins were eventually identified with their linguistic deep structure counterparts in the Case theory, Eastern ontological studies, stemming from the same origins, have still remained in the domain of hikmat philosophy. The parallelism outlined above indicates the lack of a formal linguistic approach to these insightful studies the bulk of which is in Arabic and Persian.

Any attempt at consolidating these ontological studies as linguistic syntax-oriented systems will have to fail. *However, in spite of lack of formalization, and apparent departure from formal linguistics, it should be admitted that these studies have captured the essence of deep structure relations. They should be formalized if necessary, and amended with the achievements of modern linguistic theories; by no means should they be neglected or ignored. In this way the endeavors and achievements of scholars of Classical Greek; e.g. Aristotle, Medieval Islam; e.g. Al-Farabi, Ibn Sina, and Modern Linguists like Chomsky, Lakoff, and Fillmore will unanimously be focused on syntax as a unified, self-sufficient system of high level abstract versus low level Function relations on the one hand, and atomic relations among specific nominals and verbals at each high or low level specific juncture on the other hand.*

1.4.2 My Framework

In order to synthesize the work of the philosophers and logicians of medieval Iran and the modern linguistic theories the following steps are taken :

a) the concept of 'existence' is introduced as a projectory mechanism relating the real world [see Wittgenstein 1922: 37 ff.] to the linguistic media;

b) logic-oriented linguistic transformational rules and

rule-features are devised to account for the level at which different sentence types are derived; (e. g. they specify whether a sentence is derived exclusively on the level of abstractions or functions), as well as the level specified by lower level rules which specify the various functional loads of 'univocals' in terms of the nominals with which it is 'fused' and in terms of the levels at which the 'fusion' is completed. To put it differently, the linguistic act is first analyzed through feature specification into sentence levels. Then each sentence level is further analyzed in terms of the number and the type of nominal and verbal 'fusions' at different verb levels (details will follow). In this way the sentence and consequently the linguistic media are analyzed in terms of the atomic facts that constitute Nominal and Verbal relations [see Chomsky 1968: 10];

c) lexical and phonological rules 'convert' the deep structure of the language, in this case, Persian, into surface structure.

The system that will be partially outlined below for the syntax of language will be fully justified in the next two chapters. In this introductory chapter only the outline of the system, and a brief 'history' of logical and linguistic treatment of syntax will be hinted at.

1.4.2.1 Outline of Syntactic Relations²¹

The system that I will outline below for the syntax of language takes syntax at its most abstract level. The diagram on the next page (Fig. 1: Syntactic Relations) is designed to show my view of the syntax of language achieved through analyzing various types of Persian structures. It reveals syntax as a Unified System (US) resulting from the 'interpretation' of a Neutral System (NS) into a Hypersystem (H). Hypersystem is a fictitious 'cover term' referring to the combination of three Subsystems; the Abstract Subsystem (Abst. Subs.), the Abstract-Function Subsystem (Abst.-Func. Subs.), and the Function Subsystem (Func. Subs.). The 'interpretation' of the Neutral System into each of the Subsystems of the Hypersystem, is done through a Feature Specification System (FSS). This latter decides the hier -

Figure 1
Syntactic Relations

The 'conversion' of the Neutral System into the Subsystems of the Hypersystem through the Feature Specification System.

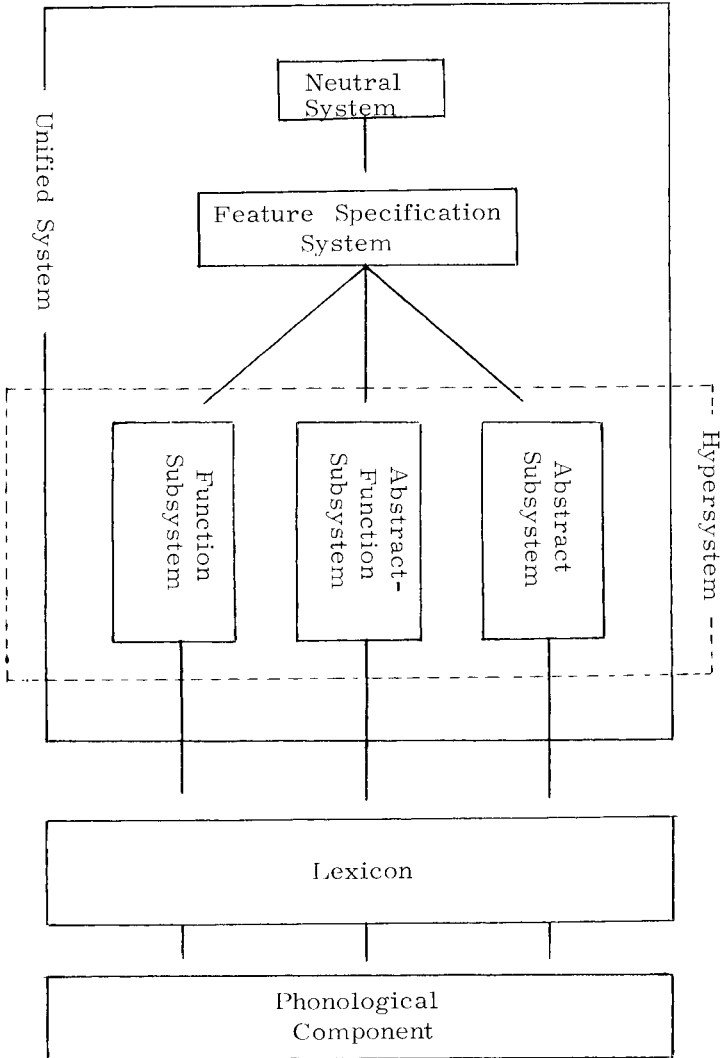

archical order according to which the three Subsystems are arranged within the Hypersystem. The choice of the 'interpretation' of the Neutral System into the hierarchy of Subsystems of the Hypersystem is also handled by the FSS.

For each sentence, the Neutral System, essentially a neutral inventory of transformational mapping rules and features, is 'interpreted' into one and only one of the Subsystems through the intermediacy of the Feature Specification System. After this modification, the undefined string that has started as the output of the Neutral System, first goes through the Lexicon, then through a set of transformational rules in the phonological component. The eventual result of these modifications of the Neutral System will be a particular sentence derived at a special level of Abstraction or Functionality. It can be classified according to the level at which its verb is functional and analyzed for the internal structuring of its nominals and verbals. (The Phonological and the Lexical components will not be dealt with in this study.)

The internal structuring of the Neutral System and consequently its 'conversion' into different Subsystems is done by Transformational Mapping and Correlative Mapping (TMCM) rules. These rules result in a hierarchically ordered set of Neutral Slots in the Neutral System. Each Neutral Slot is derived from its preceding slot by the application of one TMCM rule. The last slot has the accumulated information of all preceding slots.

Sentences generated by this grammar fall within the range of one of the three Subsystems, depending on the combination of TMCM rules of the NS and the rules of the FSS involved. If the rules applied result in a physical realization of the real world, we are dealing with a sentence within the Function Subsystem. If the rules applied result in an abstract realization, we are dealing with a sentence in the Abstract Subsystem. Finally, if the rules applied result in a 'mixture' of the two, we are dealing with a sentence in the Function-Abstract Subsystem.

1.4.2.2 Contributions of This Framework

The contributions that a system of the type outlined above make to the general theory of syntax for the explication of linguistic structures are numerous. Most of these have already been discussed, but some have hardly been dealt with in the context of a unified syntactic theory.

The main objective of this study is to present syntax as a unified system comprising diverse neutral, universal relations (sensitive to feature specification) derived from a central notion 'BE' in terms of mapping rules and their correlatives. Furthermore, this framework suggests that transformational rules should be basically utilized for derivational rather than 'filtering' purposes. Filtering should be referred to a less powerful component like the atomic relations between the nominals and verbals. Such a constraint on the grammar will not have to face the power of the uncontrollable generalized phrase markers and, thus need not be 'weakened' by transformational rules of the type current in the theory. It is evident now that the existence and nonexistence of the current transformational rules add to the number of ill-formed sentences rather than decrease them

On lower levels this framework handles the passive in terms of function identity and relation to 'BE'. It discards the traditional notion of 'transitive/intransitive/ditransitive' by introducing verb levels, and it simplifies the embedding processes by expansion of already existing nodes rather than creating new nodes to accommodate the embedded elements [cf. also Bashiri 1972a: 41-42 and chapter three below for further detail].

¹Speaking of Meninski's dictionary Jones says:

The labours of Meninski immortalized and ruined him: his dictionary of Asiatic languages is, perhaps, the most laborious compilation that was ever undertaken by any single man; ... [Jones 1771: x].

Beside the use of this dictionary Jones also drew on the knowledge of his friend and fellow linguist Baron Reviczki for the compilation of his *Persian Grammar* [Cannon 1952: 11].

²Concerning the general development of grammars at this time, Chomsky asserts that although as early as 1788 James Beattie has shown indications of his awareness of regular and productive syntactic processes, 'no traditional or structuralist grammar goes beyond classification of particular examples to the stage of formulation of generative rules on any significant scale' [Chomsky 1965: 5].

³There can be no doubt that the field of modern linguistics and consequently the study of dialectal relationships in terms of generative phonology, and generative syntax has made tremendous progress. However, it is unfortunate to note that not a few scholars still publish material based on the prototypes handed down to them by their teachers. A comparison of Stilo [1971] and Yarshater [1969], covering near dialects, can best illustrate this dichotomy.

⁴In this study I make a distinction between the work of native grammarians who continued the study of the medieval logicians and philosophers and more modern grammarians who accepted Western innovations and wrote their grammars on the model introduced by Jones.

⁵The motivations that Jones reveals for his writing of the *Persian Grammar* are numerous; however, the most practical ones are related to helping servants of first companies settled in India who wanted to communicate with the natives, by learning the rudiments of Persian grammar in a short time [Jones 1771: xi-xiii].

⁶The translation that Francis Gladwin gives for the citation given in the text is 'I may have been causing to speak'. The causative form of the verb *goftæn* 'to say' in Persian, is *bc-hærf avertæn* 'to cause to speak', or as a rarer case *bc-goftæn vadaštæn* 'to cause to say'.

⁷The origin of Telegdi's idea regarding the relation between the sentence:

særbaz tir xorde æst.

The soldier is shot.

and the form

særbaz-e tir xord-e.

Shot soldier.

can also have stemmed from the structuralist concept of 'endocentric' and 'exocentric'.

⁸In 1967, similar contributions were made by Gernot Windfuhr in a course on Persian syntax at the University of Michigan in which he used both *Syntactic Structures* and *Aspects* as models for explicating the Persian clause structure.

⁹This statement would have to be modified if Muhammad Mo'in's 'onthological' surveys of Persian grammar either had claim to some type of theoretical justification, or at least did not use poetic forms as examples of grammatical usage [Cf. Lazard 1970: 69].

¹⁰It is hard to delimit the activities of some of the Medieval Islamic circles like *Ikhvân-i Safâ*, to either theosophy, or pure

scientific research, or 'underground' politics. The literature that has come down to us indicates that among other things they had been active in the field of linguistics [S. H. Nasr 1964].

¹¹Primarily Kasravi was not a linguist in the modern sense. His affiliation with the field of linguistics, as he describes it, stemmed from his knowledge of the languages he knew. He states that lack of correspondence between certain aspects of (Turkic) Azari and Persian indicated to him that the analysis posited by traditionalists was not right.

¹²In fact, one of the shortcomings of Lakoff and later Fillmore is their departure from the presentation of a general framework; and adherence to 'sporadic', however, 'interesting' side issues. I believe what is needed most is a general framework within which interesting observations can be examined.

¹³The notion is important for the purposes of this study as well. For instance, I will show that the inventory of categories can be limited (to two), each being related to the other in an effectum-affectum way.

¹⁴It is interesting to note that when Fillmore finally accepted the inadequacy of his 'case' theory as presented in 1968, contemporary linguists were not sure where exactly the inadequacies of the system rested.

¹⁵In fact, Fillmore makes a distinction between a 'surface case system' and 'a set of underlying cases'[Fillmore 1968: 32]. Regarding the method of relating these two systems for English he says:

The rules for English prepositions may look something like this: The A [Agent] preposition is by; the I [Instrumental] preposition is by if there is no A, otherwise it is with; the O [Object] and F [Factive] prepositions are typically zero; the B [Benefactive] preposition is for; the D [Dative] preposition is typically to; ... [Fillmore 1968: 32].

Fillmore's treatment of prepositions is hardly different from Chomsky's attempt to correlate the surface and deep structures by mechanistic rules. His intermediate case set up K+NP, for which he claims a universal character [Fillmore 1968: 33] is not as much related to his basic (Actor-Action relations) assumption as it is to the surface realizations (prepositions) for which he has posited his 'Kasus'.

¹⁶I am using the word 'reveal' in a special sense. Lakoff's view of the abstract, although insightful, does not constitute any system within which the abstract is treated as a level, component, or some other part of a system. His grammar seems like a fictitious 'dummy' relating a series of 'suppose' rules written for a universal language with examples taken from English.

¹⁷It should be noted that Baumann, in his Die generative Grammatik und Wilhelm Humboldt, asserts that Chomsky has gravely misinterpreted Humboldt's assertions about the nature of generative grammars [Hans-Heinrich Baumann 1971: 1-12]. Lambert's assertion about Chomsky's lack of proper treatment of Humboldt's view is summed up in '[he] explored it[Humboldt's view] very little' [Lambert 1969: 7].

¹⁸The problem of 'meaning' has been discussed by Katz and Fodor in The Structure of a Semantic Theory. They assert that 'semantics suffers not from a dearth of facts about meanings and meaning relations in natural languages, but, rather from the lack of an adequate theory to organize, systematize, and generalize those facts' [Katz and Fodor 1964: 480].

¹⁹Grammar in medieval European studies was part of a trivium which consisted of a) grammars, b) rhetorics, and c) dialectics. Besides these liberal arts there was a quadrivium which consisted of a) arithmetic, b) geometry, c) music, and d) astronomy. These latter were called the mathematical arts. Both the liberal arts and the mathematical arts were prerequisites for the study of philosophy.

²⁰Although the grammar which constitutes the basis of Ibn Sina's mæntiq 'logic' is soon 'transformed' into a treatise on logical deductions, it reveals a 'primitive' view of grammar; one in which 'meaning' takes precedence over form. This is, of course, due to the logical nature of language. As a matter of fact, the word logic in Arabic is derived from the triliteral base n-ṭ-q meaning 'speech'.

²¹I am well aware of Postal's assertions regarding 'terminological fence building' by certain linguists, but at the same time cannot disregard his assertion on the same page which reads:

We are, in short, really almost at the beginning of the study of the incredibly complex and still largely unknown domain of natural language grammar [Postal 1971: 4].

How else, I wonder, can one explain a complex system [Cf. also Jespersen 1965: 341-43].

Chapter Two

ASSUMPTIONS AND DERIVATIONS

2.1 Introduction

At the outset of the chapter, I would like to assure the reader that the framework presented in chapter one will be easily understandable after its details are presented in abstract form below.

In this chapter I present my basic assumptions, and supplement them with diagrams showing the 'abstract' deep structure derivation of the internal hierarchies in each of the subsystems of the Hypersystem (see figure 1: Syntactic Relations, on page 37). This is done by analyzing the internal structuring of the neutral hierarchy in the Neutral System on which the specified hierarchies of the Hypersystem are based. The mechanism underlying the specification of the neutral hierarchy of the NS into specified hierarchies of the Hypersystem consists of an inventory of rule features called the Feature Specification System (FSS). The procedure for the conversion is as follows:

$$\begin{aligned} (1) \quad \text{NH} + \text{FSS}_f &\longrightarrow \text{H}_f \\ \text{NH} + \text{FSS}_{f-a} &\longrightarrow \text{H}_{f-a} \\ \text{NH} + \text{FSS}_a &\longrightarrow \text{H}_a \end{aligned}$$

That is, if the neutral hierarchy (NH) is specified by function (f) feature specification rules of the FSS, it will automatically be 'converted', i.e. transformed, into a

functional hierarchy in the Hypersystem. The same transformational specification procedure is true for the transformation of the neutral hierarchy into the other two subsystems of the Hypersystem; namely function-abstract (f-a) and abstract (a) subsystems.

All the processes mentioned above will be discussed in abstracto. None of the derivational 'histories' presented will include surface realization.

The derivatory mechanisms described above function in the context of a Unified System. The justification for the necessity for such a system as well as my position regarding the verb budæn 'be' as a unifying factor in syntax conclude this chapter.

2.2 The Neutral System

In the following I will first demonstrate the creation of Neutral Slots, and their hierarchy, and confine myself to basic assumptions. The justification of these assumptions and of basic procedures in terms of the suggested framework, as well as some other linguistic frameworks will follow.

I assume that the central and most abstract essence of a sentence is 'existence', i. e. 'to be' in its ontological sense. In the following it is symbolized by BU from Persian budæn 'being'.¹ There are postulated, furthermore, two linguistic primitives--verb V and noun N--with V being of a higher order, due to the sequence of mapping rules which stem from V and are outlined further below. Thus:

- (2) real world
- BU
- linguistic primitives
- V, N

In the budæn mechanism, the real world is projected into the linguistic primitives by a projection rule (PR)

which creates:

(3) PR: BU \longrightarrow NBU + VBU



Both the diagram and the rule state that through BU the real world is projected into N and V. At this stage the projection sequence is irrelevant. Both the NBU and the VBU are expandable as a result of the two expansion rules (EX) that follow:

(5) EX: NBU \longrightarrow N + BU

(6) EX: VBU \longrightarrow V + BU

The rules presented above are diagrammed below in (7) and (8):

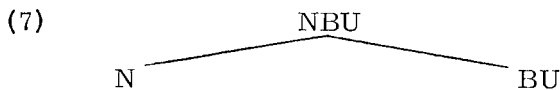

Both NBU and VBU can independently be realized as subjectless 'stative' clauses, i. e. pass through the lexical and phonological components. In that case NBU surfaces as abstractly conceptualized sentences like:

(9) mærd-æm² I am a man.

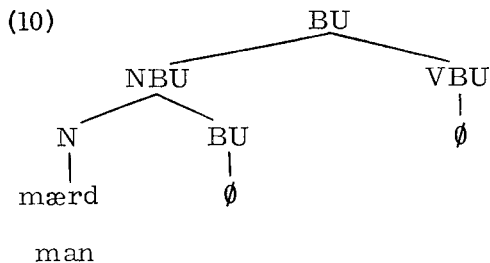

Likewise, VBU may be realized as subjectless 'stative'.

(11) hæst-æm I am

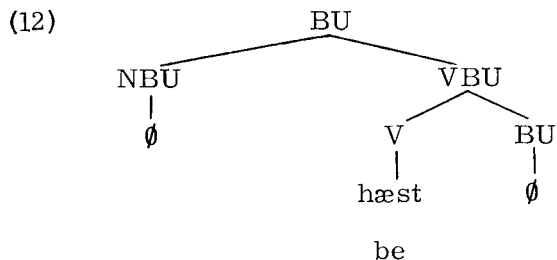

Note that here N, V, and BU are still primitives conceptualized solely through the animation (see Terminology) capability of the abstract BU component.

All sentences are created through the repeated mapping of N and V onto each other and the complex units created through such mappings. Mapping rules, which have transformational capability, serve two basic functions. In the NS they serve as 'creators' of unspecified yet potential slots which represent the degree of 'affectation' of V (verb) on N (noun). This process identifies the type of hierarchical function selection nominals undergo when they are 'affected' by a given verb. Conversely, each 'function' slot in the hierarchy which is created by a given mapping rule has the potential of reflection on the V and thereby of identifying the level of 'involvement' of the verb in the generation of each V-N string. Here, this latter is referred to as a

correlation process. The symbolic rules for correlation which are always coupled with mapping rules are called Correlative Rules (CR).

To sum up: mapping rules create potential nominal function; correlative rules 'measure' appropriate verb potency. Mapping rules are of the general form:

$$(13) A \cup B \longrightarrow C$$

read: A mapped onto B creates C.

Correlative rules are of the general form:

$$(14) C \cap A \longrightarrow DLA$$

read: C correlatively mapped into A creates the D-level of functionality of A.

2.2.1 Mapping and Correlation

Below the mechanism underlying the generation of a non-specified (neutral) string of the NS is examined:

2.2.1.1 Agent and ALV

The most crucial pair of correlative Neutral Slots valid for all sentences are Agent and the correlative Agent Level Verb. Compare the following sentences:

(15)	ræft	he went
	did ³	he saw
	mi-xor-æm	I cat
	mi-deh-æm	I give

The Agent is created by mapping V onto N:

$$(16) \text{Agent: (MR) } V \cup N \longrightarrow \text{Agent}$$

Passing through the lexicon at this stage and level would only result in slot filler since no corresponding Agent Level Verb has been created yet.

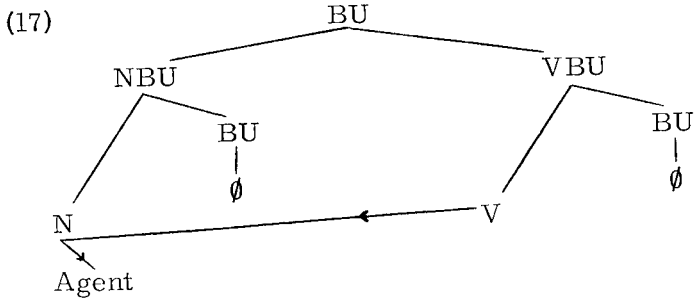

The corresponding Agent Level Verb is created through a correlative rule (CR) which maps the Agent onto the verb:

(18) ALV : (CR) Agent \cap V \rightarrow Agent Level Verb

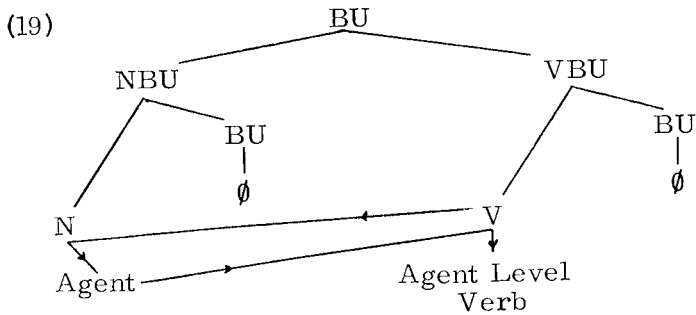

Within my system the Neutral (or Unspecified) Agent is defined as the logical sum of the linguistic primitives V and N. Its deep structure realization regarding functionality, abstraction, animation and animateness depends on the type of Feature Specifications that the FSS attaches to it as it passes through this component [see also Langendoen 1969: 148; and Lee 1971].

2.2.1.1.1 Mapping Through Agent

2.2.1.1.1.1 Source and SLV

Source is created by mapping the ALV onto the Agent.

Compare the following sentences :

- (20) a. dowlæt be-u hoquq mi-deh-æd.
 The government pays him a salary.
 b. u æz-dowlæt hoquq mi-gir-æd.
 He is paid a salary by the government.
 c. hušæng æz-beyn ræft.
 Hushang was removed (Lit. went from the middle).
 d. soqrat æz-zæhr mord.
 Socrates died from poison.
 e. æli æz-hæsan pul gereft.
 Ali took money from Hassan.

In the above sentences the underlined forms are Source. Within my framework the derivation of the Source is executed along the following path:

- (21) Source: (MR) ALV \cup Agent \longrightarrow Source

It should be noted that the Source Neutral Slot is not always realized on the surface as æz 'from'.

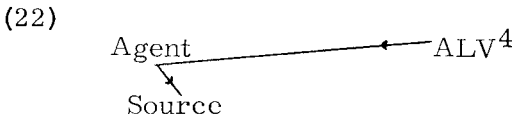

The correlative Source Level Verb is created by the following rule:

- (23) SLV: (CR) Source \cap ALV \longrightarrow Source Level Verb

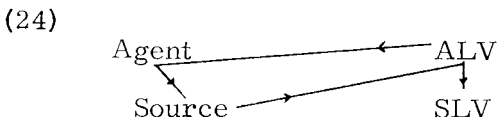

Although verbs may not have explicit Source, Source is, nevertheless, a necessary Neutral Slot for the creation of

the next lower slot, Path. Verbs without explicit Source imply it.

Within my framework Source is defined as the potential Slot from which Path, Goal, etc. come into existence, are developed and are derived by the help of the Mapping Rules.

2.2.1.1.2 Mapping Through Source

2.2.1.1.2.1 Path and PLV

The Path is created by mapping the SLV into the Source. Compare the following sentences:

- (25) a. hušæŋ ba-mæn sohbæt kærd.
Hushang talked to me.
b. hušæŋ ba-kard šir košt.
Hushang killed lions with a knife.
c. hušæŋ ba-otobus ræft.
Hushang went on a bus.
d. hušæŋ hæmrah-e æli ræft.
Hushang went with Ali.
e. hušæŋ ba-pa ræft.
Hushang went on foot.
f. hušæŋ piyade ræft.
Hushang went on foot.

The underlined forms in the sentences above are examples of Path. Within this framework the derivation of the Path is executed as follows:

(26) Path: (MR) SLV \cup Source \rightarrow Path

(27)

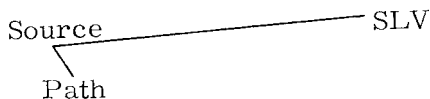

Note that the surface realization of the Path is not always marked with the preposition ba 'with'. According to Barbara Hall there are sentences which do not have

deep structure Agents but have Instrumentals. Her Instrumental is similar to my Path [Hall 1965]. Her analysis is in agreement with my view of Path as a dependent function of the Agent. (For further discussion see also Lakoff [Lakoff 1970: 145-6] and my view of dependency in Rule Dependency below.)

The correlative rule that creates the proper verb level for the Path (P) is:

(28) $PLV: (CR) \text{ Path} \cap SLV \rightarrow PLV$

(29)

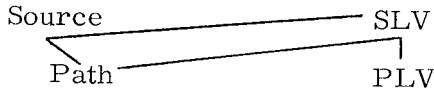

Within this framework Path is defined as a Neutral Slot into which, from the Universe of Discourse, Commitativity and Instrumentality can be mapped.

2.2.1.1.3 Mapping Through Path

2.2.1.1.3.1 Experiencer and ELV

The Experiencer is created by mapping the PLV onto the Path. Compare the following sentences:

- (30) a. reza mæn-ra zæd.
 Reza hit me.
 b. hušæng gorg košt.
 Hushang killed wolves.
 c. hušæng ba-kærd gorg košt.
 Hushang killed wolves with a knife.
 d. mæn æz-xæšm ba-dæst gorg-ra košt-æm.
 I killed the wolf with (my) hands out
 of anger.

Note that the Experiencer is independent of the surface structure anaphoric marker -ra or its equivalent.

The underlined forms above are examples of Experiencer.

e. an-ha-ra padaš dad-im.
We rewarded them.

Note that the surface realization of the Goal function is not always be- 'to'. The underlined forms in the sentences above are Goal. Within my system the derivation of the Goal is executed along the following path.

(36) Goal: (MR) ELV \cup Experiencer \rightarrow Goal

(37)

The correlative rule that creates the proper verb level for Goal is:

(38) GLV: (CR) Goal \cap ELV \rightarrow GLV

(39)

Within my framework Goal is defined as a Neutral Slot directing the power stemming from the Agent provided there are deep structure realizations for the operativity of the Agent function power.

2.2.1.1.5 Mapping Through Goal

2.2.1.1.5.1 Object and OLV

The Object is created by mapping the GLV onto the Goal. Compare the following sentences:

- (40) a. hušæng kar kærd.
Hushang worked.
b. hušæng yæx bæst.
Hushang froze.

- c. hušæng ab pašid.
Hushang sprinkled water.
- d. hušæng pul gereft.
Hushang took money.
- e. hušæng seda dad.
Hushang made noise.

The underlined forms in the sentences above are examples of Object. Within my framework the derivation of the Object is executed along the following path:

(41) Object: (MR) $GLV \cup \text{Goal} \rightarrow \text{Object}$

(42)



The correlative rule that creates the appropriate verb level for the Object is:

(43) OLV: (CR) $\text{Object} \cap GLV \rightarrow \text{OLV}$

(44)

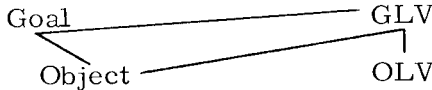

Within my framework the Object is defined as a Neutral Slot carrying the accumulated power stemming from the Agent. It is the slot which is most utilized in active concept formation (see below).

2.3 Summary: Neutral System

The Neutral System consists of a hierarchy of Neutral nominal and correlative verbal potential slots. The nominal slots are 'created' through mapping the postulated V onto N. The verb potency slots are created by mapping back each 'affected' nominal into the verb to 'measure' the

degree of V-N 'affectation'.

So far in the derivation we have been concerned with neutral, i. e. unspecified but potential nominal and verbal slots. Their participation or lack of participation in the 'bone structure' of the Neutral System indicates compatibility of certain Noun and Verb concepts and nothing more.

In order for a potential neutral or unspecified slot to be specified it has to pass through a three part system of specifiers called the FSS. It is the combinatory result of NS+ FSS that classifies the output string as to its place in the Hypersystem.

2.4 Feature Specification System

2.4.1 Functionality

Suppose that every linguistic element NBU has among its inherent features [\pm Physical], and assume also that every linguistic element VBU has among its inherent features [\pm Function].

The Transformational Mapping and Correlative Mapping rules outlined for the creation of the Neutral System are coupled with Feature Specification Mapping and Correlative Mapping rules to define the position of the Neutral System relative to the Hypersystem. These latter rules are called Feature Specification rules because they identify the marked level of the Hypersystem. In this study I will assume that the Neutral System specified by 'function' alone constitutes the unmarked level of the Hypersystem. I will refer to this unmarked level as the level of Functions. The explanatory power of the system lies in its reduction of the number of Feature Specification rules by counting only the function 'charged' rules [see Lakoff 1970: 21]. Those which are not counted create the level of Abstractions and the 'Mixed' level.

Feature Specification rules will be derived in the same manner as the slots of the Neutral System. Below I will illustrate the mechanism for derivation of Function Slots, from the Neutral Slots described above.

2.4.1.1 Feature Mapping and Correlation2.4.1.1.1 Functionality and Function Level (FL)

Functionality is created by coupling the Transformational Mapping and Correlative Mapping rules presented for the Neutral Slots, with the following Feature Specification rules:

$$(45) \begin{bmatrix} +\text{Phys.} \\ +\text{Func.} \end{bmatrix} : (\text{MR}) [+ \text{Func.}] \cup [+ \text{Phys.}] \rightarrow \begin{bmatrix} + \text{Phys.} \\ + \text{Func.} \end{bmatrix}$$

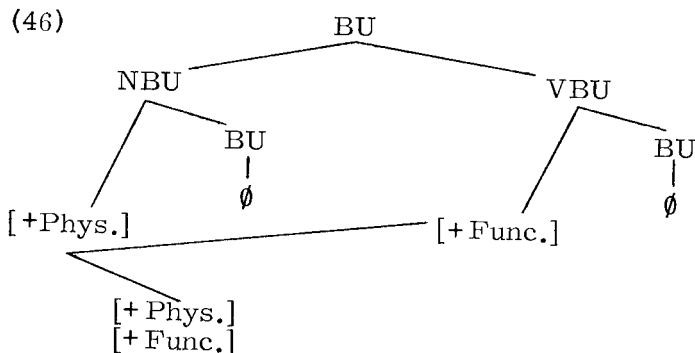

Passing through the Lexicon at this stage and level would result in a concrete slot filler since no corresponding Function Level has been created yet.

The corresponding Function Level (FL) is created through a Correlative rule which maps Functionality, namely $\begin{bmatrix} +\text{Phys.} \\ +\text{Func.} \end{bmatrix}$ onto the original [+Function].

$$(47) \text{FL: } (\text{CR}) \begin{bmatrix} +\text{Phys.} \\ +\text{Func.} \end{bmatrix} \cap [+ \text{Func.}] \rightarrow \text{FL}$$

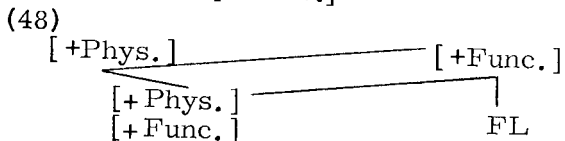

The above mechanism is responsible for converting the Neutral System into a Physical, concrete and thus Functional system to constitute the Function Level of the Hypersystem. Unlike the case of the Neutral Slots, which could not be specified in terms of Function, namely Actor-Action relations, the Functional Slots and the above Feature Specification rules, can be specified in terms of Physical relations. Below I will show the Functional Agent as opposed to the Neutral Agent. The process, of course, is taking place on the Functional Level of the Hypersystem [see Figure 1: Syntactic Relations on Page 37].

2.4.1.1.1.1 Functional Agent and ALV

Functional Agent is created by coupling the transformational Mapping and Correlative Mapping rules presented for Neutral Agent Slot with Mapping and Correlative Mapping Feature Specification rules.

$$(49) \begin{array}{l} \text{Agent} : (\text{MR}) \text{ V} \quad \quad \quad \cup \quad \text{N} \quad \rightarrow \quad \text{Agent} \\ \begin{array}{l} [+Phys.] \\ [+Func.] \end{array} \quad \begin{array}{l} [+Func.] \\ \end{array} \quad \begin{array}{l} [+Phys.] \\ \end{array} \quad \begin{array}{l} [+Phys.] \\ [+Func.] \end{array} \end{array}$$

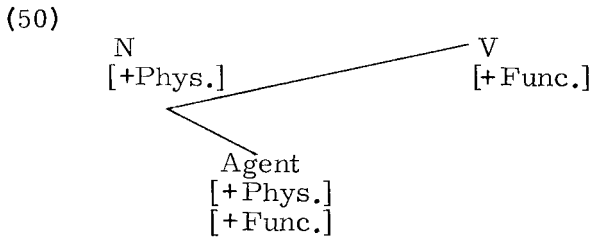

The corresponding $\begin{array}{l} \text{ALV} \\ [+Func.] \end{array}$ is created through a Correlative rule which maps $\begin{array}{l} \text{Agent} \\ [+Phys.] \\ [+Func.] \end{array}$, or Functional Agent onto the $\begin{array}{l} \text{V} \\ [+Func.] \end{array}$:

$$(51) \text{ALV} \begin{matrix} [+ \text{Func.}] \end{matrix} : (\text{CR}) \begin{matrix} \text{Agent} \\ [+ \text{Phys.}] \\ [+ \text{Func.}] \end{matrix} \cap \begin{matrix} \text{V} \\ [+ \text{Func.}] \end{matrix} \longrightarrow \begin{matrix} \text{ALV} \\ [+ \text{Func.}] \end{matrix}$$

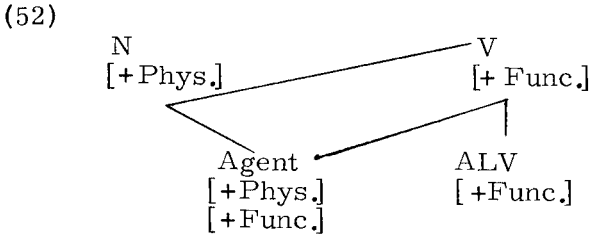

Thus, Functional Agent will be defined in terms of the logical sum of the linguistic primitives V and N; the logical sum of their inherent positive features, and the receptivity of its N to animateness. In fact, each one of the Neutral Slots introduced in the structuring of the Neutral System has a Functional counterpart within the Function Subsystem of the Hypersystem. Consequently, each of the levels of the hierarchy of Functions should be defined in terms similar to those given above for Functional Agent. (For examples and explanation see below.)

2.4.2 Nonfunctionality

Nonfunctionality is created by coupling the Transformational Mapping and Correlative Mapping rules of the Neutral System with the following Feature Specification rules:

$$(53) \begin{matrix} [-\text{Phys.}] \\ [-\text{Func.}] \end{matrix} : (\text{MR}) [-\text{Func.}] \cup [-\text{Phys.}] \longrightarrow \begin{matrix} [-\text{Phys.}] \\ [-\text{Func.}] \end{matrix}$$

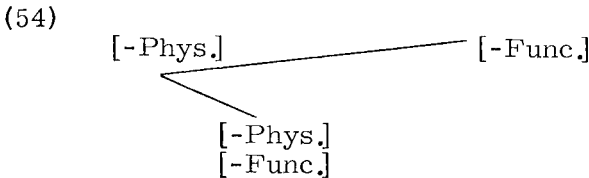

The corresponding -FL is created through a Correlative rule which maps Nonfunctionality, namely [-Phys.] onto the original [-Function].

$$(55) \text{-FL: (CR) } \begin{matrix} [-\text{Phys.}] \\ [-\text{Func.}] \end{matrix} \cap [-\text{Func.}] \longrightarrow \text{-FL}$$

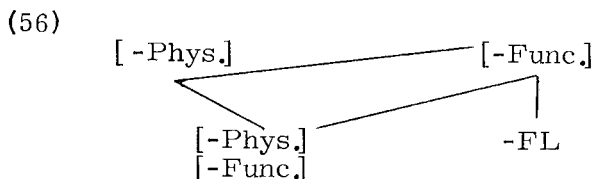

The above mechanism is responsible for converting the Neutral System into an Abstract Nonfunctional Subsystem, to constitute the Abstract Subsystem of the Hypersystem.

Unlike the case of the Neutral Slots which could not be specified in either Functional or Abstract terms, the slots resulting from the combination of Neutral Slots and the above Feature Specification rules, can be specified in terms of Abstract relations. Below I will show this Abstract specification of Nonfunctional Agent as opposed to the Neutral Agent specified earlier [see 2.2.1.1 above].

2.4.2.1 Nonfunctional Agent and Nonfunctional ALV

Nonfunctional Agent is created by coupling the Transformational Mapping and Correlative Mapping rules presented for Neutral Agent Slot with Mapping and Correlative Mapping Feature Specification rules above:

$$(57) \text{Agent } \begin{matrix} [-\text{Func.}] \\ \end{matrix} : (\text{MR}) \begin{matrix} \vee \\ [-\text{Func.}] \end{matrix} \cup \begin{matrix} \text{N} \\ [-\text{Phys.}] \end{matrix} \longrightarrow \text{Agent } \begin{matrix} [-\text{Phys.}] \\ [-\text{Func.}] \end{matrix}$$

(58)

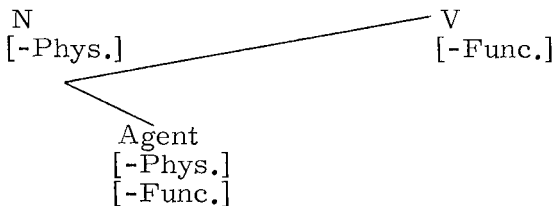

The corresponding $\text{ALV} \begin{bmatrix} -Func. \end{bmatrix}$ is created through a correlative rule which maps the Nonfunctional Agent onto the $V \begin{bmatrix} -Func. \end{bmatrix}$.

(59) $\text{ALV} \begin{bmatrix} -Func. \end{bmatrix} :(\text{CR}) \text{Agent} \begin{bmatrix} -Phys. \\ -Func. \end{bmatrix} \cap V \begin{bmatrix} -Func. \end{bmatrix} \longrightarrow \text{ALV} \begin{bmatrix} -Func. \end{bmatrix}$

(60)

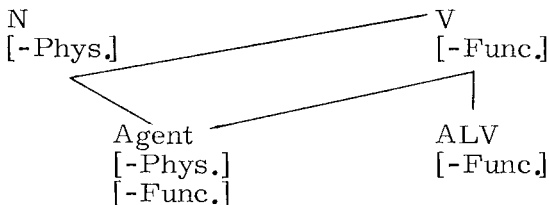

Thus, Nonfunctional Agent will be defined in terms of the logical sum of the linguistic primitives V and N, the logical sum of their inherent negative features, and receptivity of its N to animation. In fact, each one of the Neutral Slots introduced in the structuring of the Neutral System has a Nonfunctional counterpart within the Abstract Subsystem of the Hypersystem. Consequently, each of the levels of the hierarchy of Abstracts should be defined in terms similar to those for the Nonfunctional Agent. (For surface examples and explanation see Chapter Three below.)

2.4.3 Functionality and Nonfunctionality 'Mixed'

2.4.3.1 Physicality

The hierarchy of Functions is derived from the Neutral System through coupling it with positive Feature Specification rules. The hierarchy of Abstractions is also derived from the Neutral System, but through coupling it with Negative Feature Specification rules. Between these two Function and Abstraction extremes lies a 'mixed' hierarchy; a hierarchy the Function or Abstraction orientation of the levels of which depends on the Function or Abstraction orientation of particular levels at certain points in the derivation. Thus, it will be possible to have a Functional verb in an otherwise Abstract sentence. Later I will show examples of these borderline cases.

If the feature [-Function] is mapped into [+Physical] the result will be a Physical, but Nonfunctional slot.

$$(61) \begin{bmatrix} +\text{Phys.} \\ -\text{Func.} \end{bmatrix} : (\text{MR}) [-\text{Func.}] \cup [+ \text{Phys.}] \longrightarrow \begin{bmatrix} +\text{Phys.} \\ -\text{Func.} \end{bmatrix}$$

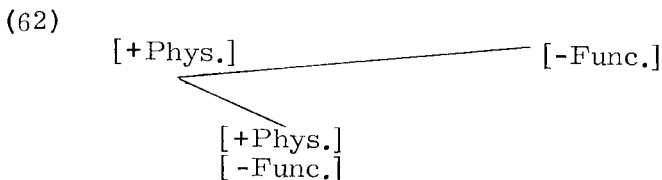

The corresponding Nonfunction Level (-FL) is created through the following correlative rule:

$$(63) -\text{FL} : (\text{CR}) \begin{bmatrix} +\text{Phys.} \\ -\text{Func.} \end{bmatrix} \cap [-\text{Func.}] \longrightarrow -\text{FL}$$

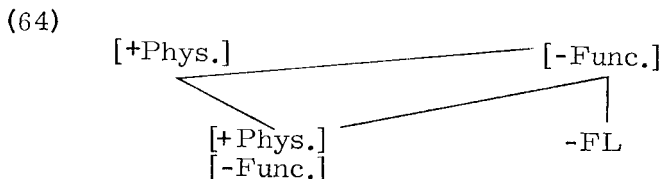

The -FL plays an important part within the hierarchy of Function-Abstractions; because this is the component which signals the changes in the orientation of the whole sentence.

The above mechanism converts the Neutral System into a Physically oriented hierarchy, constituting the Physical compartment (see below) of the Abstract-Function Subsystem of the Hypersystem.

2.4.3.1.1 Physical Agent and Physical ALV

Physical Agent is created by coupling the Transformational Mapping and Correlative Mapping Feature Specification rules above:

$$(65) \text{ Agent} : (\text{MR}) \text{ V} \cup \text{ N} \longrightarrow \text{Agent}$$

$$[\text{+Phys.}] \quad [\text{-Func.}] \quad [\text{+Phys.}] \quad [\text{+Phys.}]$$

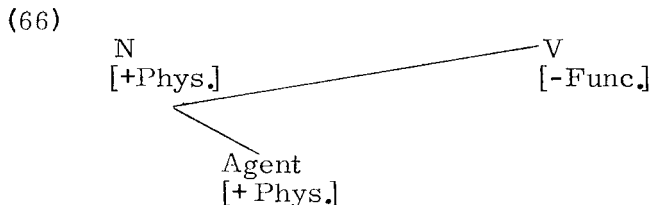

The corresponding Physical ALV is created through the following correlative rule:

$$(67) \text{ ALV} : (\text{CR}) \text{ Agent} \cap \text{ V} \longrightarrow \text{ALV}$$

$$[\text{-Func.}] \quad [\text{+Phys.}] \quad [\text{-Func.}] \quad [\text{-Func.}]$$

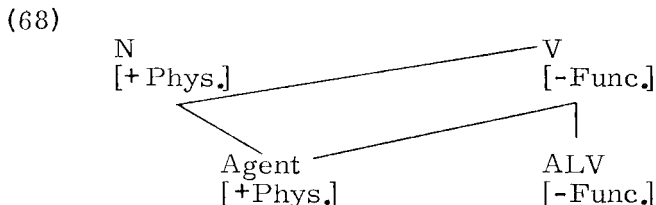

Thus, Physical Agent will be defined in terms of the logical sum of the linguistic primitives V and N, the logical sum of their respective inherent features and the receptivity of its N to animation. Each one of the Neutral Slots introduced in the structuring of the NS has a Physical counterpart within the 'mixed' hierarchy of Function-Abstraction, a Subsystem of the Hypersystem. Consequently, each of the levels of the 'mixed' hierarchy should be defined in terms similar to those for the Functional and Non-functional Agent. (For surface examples and further explanation see below.)

2.4.3.2 Nonphysicality

If the feature [+Function] is mapped into [-Physical] the result will be a Nonphysical, nevertheless, Functional Slot.

$$(69) \begin{matrix} [-Phys.] \\ [+Func.] \end{matrix} : (MR) \begin{matrix} [+Func.] \\ [-Phys.] \end{matrix} \cup \begin{matrix} [-Phys.] \\ [+Func.] \end{matrix} \rightarrow \begin{matrix} [-Phys.] \\ [+Func.] \end{matrix}$$

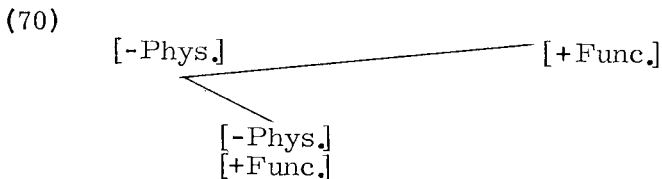

The corresponding correlative for the creation of FL is given below.

$$(71) FL : (CR) \begin{matrix} [-Phys.] \\ [+Func.] \end{matrix} \cap \begin{matrix} [-Phys.] \\ [+Func.] \end{matrix} \rightarrow FL$$

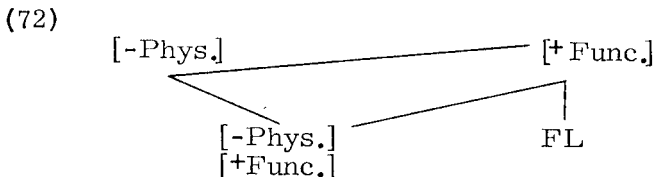

The above mechanism converts the Neutral System into a Nonphysical oriented hierarchy, constituting the Non-physical compartment of the Abstract-Function Subsystem of the Hypersystem.

2.4.3.2.1 Nonphysical Agent and Nonfunctional ALV

The Nonphysical Agent is created by coupling the Transformational Mapping and Correlative Mapping rules of the Neutral Agent Slot with mapping and Correlative Mapping Feature Specification rules above:

$$(73) \text{ Agent} : (\text{MR}) \quad \text{N} \quad \cup \quad \text{V} \quad \longrightarrow \quad \text{Agent} \\ [-\text{Phys.}] \quad [+ \text{Func.}] \quad [-\text{Phys.}] \quad [-\text{Phys.}]$$

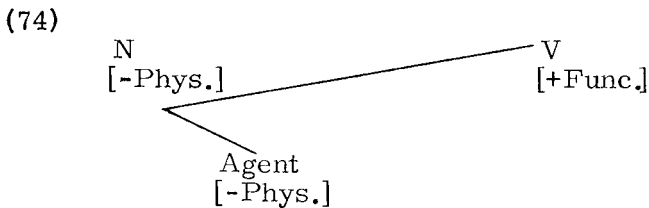

The corresponding Functional Agent Level Verb is created through the following correlative rule:

$$(75) \text{ ALV} : (\text{CR}) \quad \text{Agent} \quad \cap \quad \text{V} \quad \longrightarrow \quad \text{ALV} \\ [-\text{Func.}] \quad [-\text{Phys.}] \quad [+ \text{Func.}] \quad [-\text{Func.}]$$

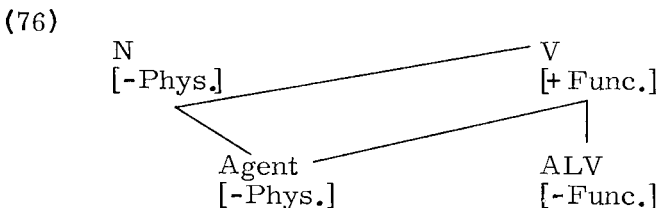

Thus, Nonphysical Agent will be defined in terms of the logical sum of the linguistic primitives V and N, the logical sum of their respective inherent features and recep-

tivity to animation. All the Neutral slots introduced in the internal structuring of the NS have a Nonphysical counterpart in the Nonphysical component of the hierarchy of Function-Abstraction. Consequently, all levels of the hierarchy should be defined in terms similar to the Nonphysical Agent. (For surface examples and further explanation see Chapter Three below.)

2.5 Restrictions on the FSS

The Feature Specification System of the grammar partially presented above is the most complicated part of the whole system; because in this component, all logical transitions which mostly surface in univocal forms are systematically distinguished. Due to the complexity of the Feature Specification component, it is feasible to explore only some possible transitions postulated to account for relations between the hierarchies, in the Function-Abstraction subsystem, under Physical and Nonphysical subcomponents. Consequently, the derivational histories presented below relate only to the types of deep structures which I have discussed above.

2.6 The Unified System

My argument in favor of the necessity for setting up a Unified System of the kind partially presented in Chapter One and in this chapter rests on two issues. One is the inadequacy of the systems presented so far for syntactic analysis, and the other is the centrality of 'existence' in the syntax of language. My central assumptions outlined above enable me to make a distinction between language as a set of relations (these originally were introduced as an ad hoc set, determined chiefly by intermediate, or even surface realizations [Nilsen 1971: 6ff.], and language as a set of hierarchically ordered deep structure relations; namely relations which are unified through 'existence'.

2.6.1 The Sentence

The inadequacies referred to above are best seen in the definition of the basic and fundamental unit of language: the sentence [cf. David Crystal: 200-208]. Before the advent of case grammar, the linguistic term 'sentence' was variously defined as 'a group of words expressing a complete thought' [Roberts 1964: 407], 'a structured string whose words fall into natural groups' [Jacobs and Rosenbaum 1968: 15], 'a notion which belongs to the world of abstract elements' [Jacobs and Rosenbaum 1968: 273], and eventually the expansion of a noun phrase and a verb phrase:

(77) #S# \rightarrow NP + VP [Chomsky 1957: 65]

Fillmore defined sentence as the expansion of a tenseless set of relationships involving verbs, nouns, and embedded sentences called Proposition and a separate 'Modality' component.

(78) S \rightarrow M + P

The first definition above is a notional definition, and cannot take us far, because as Roberts indicates, if we ask what a 'complete thought' is, the answer would be 'that which is expressed by a sentence' [Roberts 1964: 407]. The next definition, although devoid of linguistic relationship, conveys the concepts 'structured' and 'natural'. However, it does not specify the criteria for 'order' according to which the words are naturally arranged within the groups in the string.

'The world of the abstract elements' is a good place to begin, but it will eventually result in a totally abstract grammar with little relation to the real world [see Terminology].

This last definition of the linguistic term 'sentence', nevertheless, becomes an implicit notion in the definition that the generative grammarians give for it: the expansion of a noun phrase and a verb phrase. It is the mechanistic aspect of this definition that forced the generative gram-

marians to admit deficiency in their system. In Chomsky's words:

... , there is no way of ordering the elements NP and VP relative to one another. Noun phrases are contained within verb phrases, and verb phrases within noun phrases... [Chomsky 1957: 32].

Chomsky thus asserts that there is a natural order worked into the syntax of language which order handles the different realizations of the same elements, e. g. surface Subjects, in relation to different functions that are related to it in the deep structure. Further, he admits that this natural order cannot be captured without the help of mechanistic rules superimposed on the unnatural output of a series of phrase structure (PS) rules [Cf. Robinson 1970: 259]. His system admits that the phrase structure, as presented in the literature on generative methods, is deficient and has to be accompanied by a set of presurface transformational or adjustment rules which put the output of PS rules in a 'correct' order, so that it can correspond to the order in the superficial structure.⁵

To sum up, by the time Fillmore's work appeared the necessity for a radical change from the generative transformational model to a different model was evident [Lambert 1969: 39]. The Chomskian generative transformational theory with its mechanistic PS rules, which only could aim at the production of the deep structure, was not able to satisfactorily correlate the logical structure of the sentences of language with their surface structure realizations. (For further discussion of Chomsky and Lakoff's view of him see 1.3.2.1 above.)

Fillmore's concept of 'relationship' among the two basic elements of the sentence reveals a good insight into the mechanism of language, but does not involve itself with such linguist requirements as naturalness.

To synthesize the basic concepts proposed by Chomsky and Fillmore it is necessary to find a unifying factor, a common denominator, which does without the mechanistic

use of NP/VP constitution, yet utilizes nominal-verbal derivations to create 'relationships'. Although this calls for a two hundred and first [Cf. Crystal 1971: 79] definition for the term sentence, the addition seems indispensable. Since the change of definition will necessarily affect the definition of the components, I will present my definition for verb (V) and Noun (N), first:

Verb is defined as the result of the gradual 'effect' of Agent, etc. on action in such a way that at each point in the process the degree of the 'effect' can be measured.

Noun is defined as the result of the gradual 'affectation' of action on Agent, etc. in such a way that at each point in the process the type of 'affectation' can be distinguished.

The projection mechanism that connects the real world (not in concreto) and the two above mentioned essences, is 'existence' defined as a concept that unifies all different and disparate things in the world into one class in which they are reduced to a level of ontological indiscriminate-ness [Izutsu 1969: 124]. The conceptualization of 'existence' acts as the principle of identity and unity of existence with either of the individual primitives V and N. The realization of existence is the logical sum of the conceptualized primitives at different levels of linguistic function and abstraction (see below). When projected into the linguistic primitives, 'existence' can be realized as 'relations' either temporal or spatial, expressed in terms of NBU propositions such as 'such and such a thing exists in the world', 'in my mind', 'in reality', or 'in time', etc. [cf. Izutsu 1969: 89], or it is the deep structure of the 'relation' which usually surfaces in the form of particles like dær 'in'. Therefore, if the discussion refers to conceptualized essences, it is discussing the existence relationship between BU and either of the linguistic primitives (N and V), namely NBU and VBU.

On the other hand, the logical relation between two functions and an abstract verb level in a sentence of the type:

(79) æli nevisænd-e æst.

Ali is a writer.

clearly indicates that a separate set of function-abstract relationships, hierarchically ordered, are in operation. The sentences resulting from the logical sum of these function-abstraction combinations can result in the ontologized primitives realized as æli 'Ali' (subject), and nevisænd-e 'writer' (object) (in concreto) and the predicate (in abstracto) (for more details see below).

The argument presented above can be reformulated and diagrammed in the form of the following axiom:

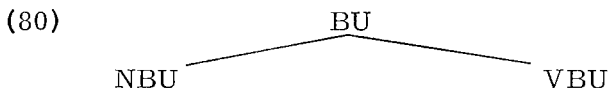

The above axiom indicates that BU (from Persian budæn 'to be') is an unbound 'existent', among all existents, at the level of ontological indiscriminateness. It is related to the Universe of Discourse (UD), through its association with the conceptualized linguistic primitives VBU and NBU. (For conceptualized primitive see Terminology.) This association creates a topmost dependency factor between each BU and the BUs to which it is related within the sphere of the UD. Thus, the deep structure of each BU becomes capable of reflecting the anaphoric and other types of reference points from the set of reference indices in the UD. Because at every point, the UD can be mapped into the elements of each BU through its sub-BU components.

An immediate advantage of this type of analysis is that each Noun can be expanded through the expansion of its BU component into a head noun with a nominal expansion. Similarly, each verb can be expanded by the expansion of its BU by mappings from the UD into it and for spatial or temporal adverbial clauses. (For further discussion see below.)

The Noun and Verb primitives discussed earlier are hierarchically ordered so that the mapping of the higher essence (V) onto the lower essence (N) always results in a neutral slot which, along with its correlative and rules that follow from them, results in two hierarchically ordered

sets of neutral slots. Each Neutral Slot within the hierarchies is supplied with a recursive mapping mechanism capable of expansion into the remotest areas from its main projecting mechanism BU. The output of the rules presented above and the correspondence of the deep and surface in all instances, plus the possibility of expansion of the BU component of nominals and verbals as nominal realizations on the one hand, and temporal and spatial on the other, persuades one to assume that there is a natural, hierarchically ordered, set of relations at work. This leads me to assert that a basic concept like Sentence should be indicative of this fact.

Thus, taking the projection of the real world onto two abstract linguistic primitive essences Verb (V) and Noun (N) into account, I redefine Sentence in terms of the logical, interdependent relations between a particular Neutral Slot (of noun) and Verb Level (of verb), hierarchically ordered, through mapping and reflecting a set of Feature Specification rules. (For details and further modifications of this definition see below.)

The term sentence thus defined is different from the current linguistic definition. It does not conceive of sentence as an upper limit, and it is not, consequently, derived from the concept of the bound sentence (#S#). It is the output of 1) a basic primitive projection (and possibly subprojections) into two linguistic primitives resulting in two linguistically oriented realizations of budæn 'existence' (the Persian 'be!'); 2) a basic expansion resulting in realization of the natural creation of deep structure relations ready to surface independent of presurface transformational adjustment rules, namely rules other than the Transformational Mapping rules outlined above; and 3) a limited number of V/N (mapping), and N/V (correlative mapping) interrelations affected by a series of negative feature correlation rules, thus creating a hierarchy of function-abstraction interdependencies.

2.6.2 Advantages of a Unified System

By means of Existent Composition rules, as well as in

the form of diagrams, I am able to show that each neutral slot NN (neutral noun) becomes operative only where it is in relation with its correlative slot, NV (neutral verb). The information concerning the number of relationships within each node NN in relation to NV is achieved through an accumulative procedure, with the lowest level rules carrying the most information about the number of mappings involved in their 'creation'. Thus, if the slots are hierarchically ordered with S_1 being the uppermost of its hierarchy and S_n the lowermost of the same hierarchy, S_n will have all the information necessary to retrace its 'history' back to S_1 .

Further advantages of a Unified System of the type outlined above are the systematic treatment of the concepts 'rule dependency' and 'rule government'.

2.6.2.1 Rule Dependency

According to the axioms of the theory outlined in this chapter Agent, while dependent on the verb, is independent of the Slots that draw on it by means of TCMC rules. These Slots are Nominal Slots derived from repeated mapping of V onto N.

[+Function]	[+Physical]
-------------	-------------

The system outlined above demands that each lower Slot be dependent on the Slot from which it is derived by TCMC rules.

Conversely, each higher Slot is dependent on the lower Slot for information on the type and number of Mapping and Correlative Mapping rules involved. This latter identifies the 'role' of each Slot in the hierarchy of Slots derived from the Agent. Compare the following sentences:

- (81) a. mæn zæd-æm.
 I hit.
 b. u ba-zænjir hušəng-ra zæd.
 He hit Hushang with a chain.

In (81-a) the Agent, mæn 'I', is independent of any lower Slots that might follow from it. On the other hand, in (81-b) neither the Path, ba-zænjir 'with chain', nor the Ex-

periencher hušæng-ra 'Hushang-Anaph.' [for Anaphoric see below] which is derived from it can be independent of the Agent u 'he', since in order for the Experiencer Hushang to experience being hit, it is necessary to have an Agent u 'he', and an instrument (Path) zænjir 'chain' to instigate and finalize the act.

The same type of binary interdependence holds among the verb levels that follow from V [±Function]. The diagram

that follows indicates the deep structure of the sentence in (81-b) as well as the interdependence discussed above. I represents information about the type and number of TM-CM. R represents the dependency of each Slot on another. Subscript numerals indicate hierarchical dependence. Thus I_{+3} represents Information regarding Function pile-up, while R_{-1} represents topmost rule independence.

In the diagram below intermediate Slots like Source (e.g. æz-xæšm 'from anger'), etc. could be supplied but are left out. [For a different view of dependency structures see Robinson 1970: 260ff.].

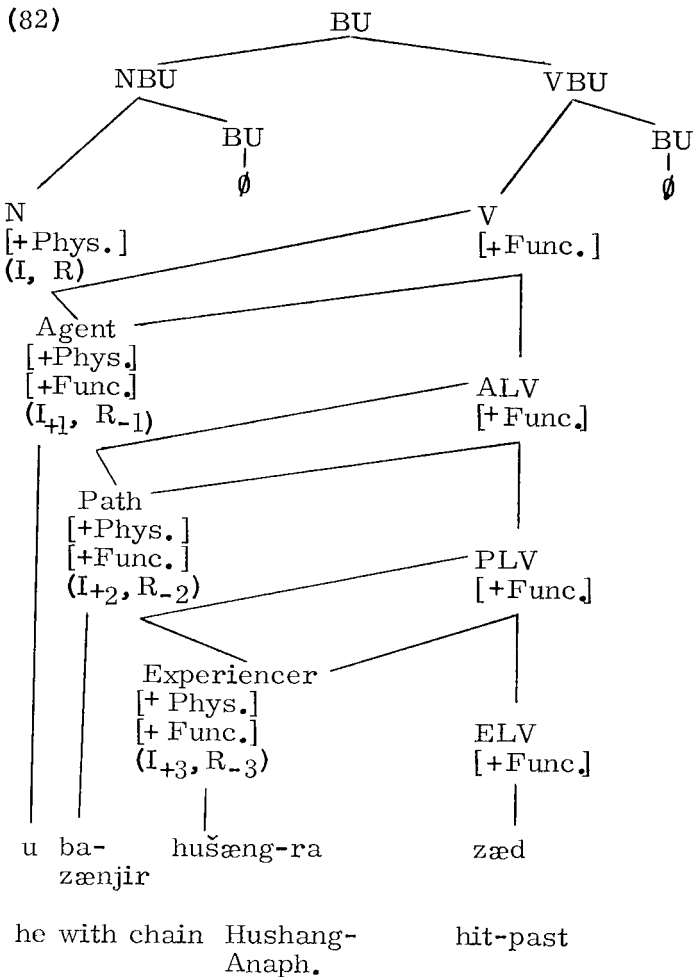

2.6.2.2 Rule Government

Rule government is in converse relationship to rule dependency [Cf. Robinson 1970: 260]. However, the nature of rule government is different from that of rule dependency. For example, it is possible for the Agent to be inde-

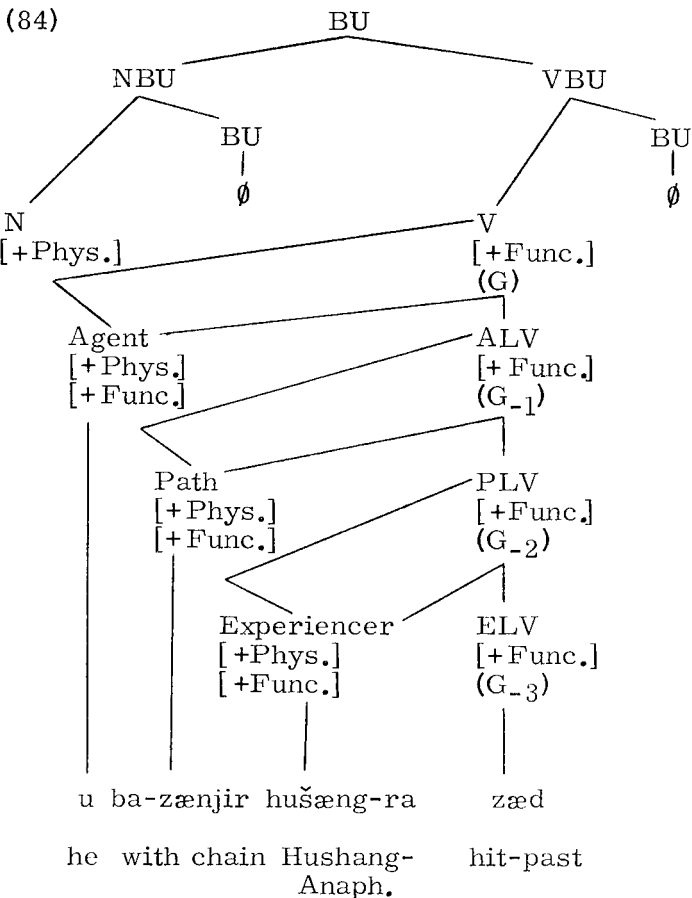

2.7 Summary of Rules

The number preceding each rule is the same as the number under which it has appeared in the text.

2.7.1 Projection

(3) (PR): BU \rightarrow NBU + VBU

2.7.2 Expansion

(5) (EX) : $NBU \rightarrow N + BU$

(6) (EX) : $VBU \rightarrow V + BU$

2.7.3 Mapping and Correlation

2.7.3.1 Rules in the Neutral System

(16) Agent: (MR) $V \cup N \rightarrow \text{Agent}$

(18) ALV : (CR) $\text{Agent} \cap V \rightarrow \text{Agent Level Verb}$

(21) Source: (MR) $ALV \cup \text{Agent} \rightarrow \text{Source}$

(23) SLV: (CR) $\text{Source} \cap \text{Agent} \rightarrow \text{Source Level Verb}$

(26) Path: (MR) $SLV \cup \text{Source} \rightarrow \text{Path}$

(28) PLV: (CR) $\text{Path} \cap SLV \rightarrow \text{PLV}$

(31) Experiencer: (MR) $PLV \cup \text{Path} \rightarrow \text{Experiencer}$

(33) ELV: (CR) $\text{Experiencer} \cap PLV \rightarrow \text{ELV}$

(36) Goal: (MR) $ELV \cup \text{Experiencer} \rightarrow \text{Goal}$

(38) GLV: (CR) $\text{Goal} \cap ELV \rightarrow \text{GLV}$

(41) Object: (MR) $GLV \cup \text{Goal} \rightarrow \text{Object}$

(43) OLV: (CR) $\text{Object} \cap GLV \rightarrow \text{OLV}$

2.7.3.2 Rules in the Feature Specification System

(45) $\begin{matrix} [+ \text{Phys.}] \\ [+ \text{Func.}] \end{matrix} : (\text{MR}) \begin{matrix} [+ \text{Func.}] \\ [+ \text{Phys.}] \end{matrix} \cup \begin{matrix} [+ \text{Phys.}] \\ [+ \text{Func.}] \end{matrix} \rightarrow \begin{matrix} [+ \text{Phys.}] \\ [+ \text{Func.}] \end{matrix}$

- (47) FL: (CR) $\begin{matrix} [+Phys.] \\ [+Func.] \end{matrix} \cap [+Func.] \longrightarrow FL$
- (49) Agent : (MR) $\begin{matrix} V & \cup & N \\ [+Phys.] & & [+Phys.] \\ [+Func.] & & [+Func.] \end{matrix} \longrightarrow \begin{matrix} Agent \\ [+Phys.] \\ [+Func.] \end{matrix}$
- (51) ALV : (CR) $\begin{matrix} Agent & \cap & V \\ [+Func.] & & [+Func.] \\ & & [+Func.] \end{matrix} \longrightarrow \begin{matrix} ALV \\ [+Func.] \end{matrix}$
- (53) $\begin{matrix} [-Phys.] \\ [-Func.] \end{matrix}$: (MR) $[-Func.] \cup [-Phys.] \longrightarrow \begin{matrix} [-Phys.] \\ [-Func.] \end{matrix}$
- (55) -FL : (CR) $\begin{matrix} [-Phys.] \\ [-Func.] \end{matrix} \cap [-Func.] \longrightarrow -FL$
- (57) Agent : (MR) $\begin{matrix} V & \cup & N \\ [-Func.] & & [-Phys.] \end{matrix} \longrightarrow \begin{matrix} Agent \\ [-Phys.] \\ [-Func.] \end{matrix}$
- (59) ALV : (CR) $\begin{matrix} Agent & \cap & V \\ [-Func.] & & [-Func.] \\ & & [-Func.] \end{matrix} \longrightarrow \begin{matrix} ALV \\ [-Func.] \end{matrix}$
- (61) $\begin{matrix} [+Phys.] \\ [-Func.] \end{matrix}$: (MR) $[-Func.] \cup [+Phys.] \longrightarrow \begin{matrix} [+Phys.] \\ [-Func.] \end{matrix}$
- (63) -FL : (CR) $\begin{matrix} [+Phys.] \\ [-Func.] \end{matrix} \cap [-Func.] \longrightarrow -FL$
- (65) Agent : (MR) $\begin{matrix} V & \cup & N \\ [+Phys.] & & [+Phys.] \\ [-Func.] & & [-Func.] \end{matrix} \longrightarrow \begin{matrix} Agent \\ [+Phys.] \\ [-Func.] \end{matrix}$
- (67) ALV : (CR) $\begin{matrix} Agent & \cap & V \\ [-Func.] & & [-Func.] \\ & & [+Phys.] \end{matrix} \longrightarrow \begin{matrix} ALV \\ [-Func.] \end{matrix}$
- (69) $\begin{matrix} [-Phys.] \\ [+Func.] \end{matrix}$: (MR) $[+Func.] \cup [-Phys.] \longrightarrow \begin{matrix} [-Phys.] \\ [+Func.] \end{matrix}$
- (71) FL : (CR) $\begin{matrix} [-Phys.] \\ [+Func.] \end{matrix} \cap [+Func.] \longrightarrow FL$

- (73) Agent : (MR) V ∪ N → Agent
 [-Phys.] [+Func.] [-Phys.] [-Phys.]
- (75) ALV : (CR) Agent ∩ V → ALV
 [-Func.] [-Phys.] [+Func.] [-Func.]

¹The study of 'existence' may take the reader to many different areas of learning and let him explore, and find an acceptable framework within which he can assert his conceptions regarding the world and its different manifestations. There is the view that connects poetic ecstasy and contemplation of Being to communication, e.g. Heidegger's 'Silent Contemplation of Being and ecstasy of poetry are the only real possibilities of Communication' [Heidegger 1935: 168ff.; 1937: 8]. This is a 'passive' view of Being quite far from the analytical view presented by Wittgenstein, for example. The framework that I have presented agrees with Wittgenstein's of which Malcolm says:

Wittgenstein's Tractatus may be called a synthesis of the theory of truth-functions and the idea that language is a picture of reality [Malcolm 1958: 8].

Tullio de Mauro, who calls Wittgenstein's ontological assertions 'linguistic solipsism', gives him full credit for his rigour and clarity:

The Tractatus opens with a solemn sequence of ontological assertions. "The world is all that is the case" (1), it "is the totality of facts" (1.2), that is, it "divides into facts" (1.2.). A fact "is the existence of states of affairs" (2) and "a state of affairs (a state of things) is a combination of objects (things)" (2.01). Since they are part of the world, pictures cannot be considered other than "facts" (2.141). But they are facts of a particular kind; they are facts which have something in common with other facts; "If a fact is to be a picture, it must have something in common with what it depicts" (2.16). This "something" is what Wittgenstein calls "form", "pictorial form" (2.171). Pictorial form is the possibility that the elements of the picture are related to one another (i.e. they have a structure) in the same way (i.e. with the same structure) as the things (objects) in a fact (2.15, 2.151).

One of the things Wittgenstein wishes to make clear is that it is not necessary for a picture to represent the fact of which it is a picture iconically in order to be such... In fact, "at first sight a proposition - one set out on the printed page, for example - does not seem to be a picture of the reality with which it is concerned. But no more does musical notation at first sight seem to be a picture of music, nor our phonetic notation (the alphabet) to be a picture of our speech"(4.011)... It is this identity of structures (that is of the relations between the elements composing them) which allows us to say that "a proposition is a picture of reality" (4.01). It is "a projection of a possible situation" (3.11), whose elements, or "simple signs", are names (3.202). Each name means an object: the object is the meaning of each name (3.203). To the configuration of names in the propositional sign corresponds the configuration of objects in correspondence, an object cannot be imagined as divorced from combinations with other objects in state of affairs (2.021), so that "only in the nexus of a proposition does a name have any meaning" (3.3)...

It may seem strange that Wittgenstein should go to the length of stating such banalities. And there is no doubt that they are banalities: if we are all to understand the greatness of Wittgenstein we must also understand that the above phrases are extremely trite. They do no more than restate the "conception superficielle du grand public" to which SAUSSURE (1922, p. 34) referred, the same "very naïve, but widespread conception of which MARTINET (1960, pp. 14-15) writes, i. e. the old Aristotelian and rationalist conception of the world and of the linguistic facts. But, as may be seen, Wittgenstein expounds an extremely rigorous version of this conception, one that is completely explicit in all its logical implications. It is this very rigour, this clarity, which allows Wittgenstein to build up the limpid and irrefutable

paradox expressed in proposition 3.263 of the Tractatus. [De Mauro 1967: 25-26].

Wittgenstein's assertions regarding the 'pictorial' relationship between the linguistic world and the world of facts in:

The meaning of primitive signs can be explained by elucidation. Elucidations are propositions which contain the primitive signs. They can, therefore, only be understood when the meanings of these signs are already known [Wittgenstein 1922: 3.263].

are seemingly paradoxical. This paradoxical character of the statements, however, can be easily removed by analyzing the statements into their immediate constituents in terms of a system dealing with projection of linguistic primitives.

²Since person and number are introduced through copying rules at a much later stage, they are left out of this study [cf. also Moyne 1970, Sadeghi 1969: 155].

³Phonological irregularities are left out of this study.

⁴For tree diagrams showing the underlying derivational processes step by step see Bashiri 1972a.

⁵This framework agrees with Wittgenstein who says:

In fact all the propositions of our everyday language, just as they stand, are in perfect logical order 5.5563 [quoted in De Mauro 1967: 5].

and proves that, except for stylistic reasons transformations of the type permutation, etc. are not needed for deep structure analysis.

Chapter Three

EXPLANATION WITH EXAMPLES

3.1 Introduction

As mentioned above, the Hypersystem is a fictitious system which draws on the Neutral System for its hierarchy of Subsystems. These Subsystems which specify sentence types are created through the application of Transformational Mapping and Correlative Mapping rules of the FSS to the NS.

So far I have discussed the internal structure of the Neutral System and the type of Feature Specification rules that modify the string initiating in the NS to be classified in only one of the Subsystems of the Hypersystem.

In this chapter I will give explanations and examples concerning each of the abstract, deep structure derivations presented above, and will furnish more details, justifications and surface examples. An important contribution of this framework lies in its systematic distinction between Function, Abstraction, and the 'borderline' at which they 'merge': Abstract-Function.

Although the level of Abstraction constitutes the base from which the other two levels should be derived, in this study, for simplicity of exposition, I will start with the description and derivation of the lowest of the levels of the Hypersystem, namely the hierarchy of Functions. This is because I assume that the hierarchy of Functions, like the other two hierarchies, is created by simultaneous application of TMCM rules of the NS and the FSS rules charged with positive values only. For the sake of simplicity of for-

mal representation, I will not 'crowd' the diagrams with higher level feature specification indicators of the type [+Physical], [+Function], or lower level features like [+concrete], [+animate]. The hierarchy of Functions will henceforth be referred to as the Unmarked Hierarchy.

3.2 The Hypersystem

3.2.1 The Unmarked Hierarchy

3.2.1.1 Agent Level Sentences

Through mapping of V [+Func.] (henceforth V) onto N [+Phys.] (henceforth N) a function F_1 is achieved. This function, as mentioned earlier, is the logical sum of V and N. I call this function the Agent [+Func.] (henceforth Agent). Conversely,

by mapping F_1 onto V, a correlative function F_2 is achieved. This correlative function indicates the level of functionality of F_1 and F_2 in relation to V. Thus, L_1 ($L_1 = F_2$) can be defined as the level at which the two functions F_1 (of Noun) and F_2 (of Verb) can combine and result in the unrealized concept of a sentence on the L_1 level. This unrealized concept, once it passes through the Lexicon, is realized as the surface example of a Functionally defined Existent Composition on that particular level. Namely, if F_1 is the Agent and is mapped onto V through a correlative mapping rule, the resulting function F_2 will be an Agent Level Verb. The combination of these two functions will result in the concept of an Agent Level Sentence which, once passed through the lexicon, surfaces as example of a Functional surface sentence of the language: Compare:

- (85) a. hušæng xord.
Hushang ate.
b. hušæng kærd.
Hushang did.
c. hušæng gereft.
Hushang took.

(For reasons for keeping the nodes BU \rightarrow \emptyset open, see 4.3).

Traditionally the term Agent has been used to mean 'nominative' as opposed to 'accusative', etc. In 1968, however, the term was redefined by Fillmore. He defined his 'Agentive' as: 'the case of the typically animate perceived instigator of the action identified by the verb' [Fillmore 1968: 25]. Although the definition given by Fillmore takes care of most of the areas in which the Agent is operative, it is a 'descriptive' rather than an Abstraction-Function oriented definition delimited and modified by the Verb. His definition does not distinguish the world of the abstract element in which the linguistic phenomena operate from the realization of the concrete world in which John and Joe perform. In fact, Fillmore totally ignores this sharp distinction outlined by Chomsky and partially developed by Lakoff. This neglect of the Abstract-Function dichotomy and adherence to a unilevel grammar is one of the reasons why case grammar could not satisfactorily handle the 'stative', or verbs of more abstract nature like daštæn 'to have' [see Lee 1971: L-25]. If one would follow Fillmore's definition for Agent, it would be impossible to account for the function of mærd 'man' vis à vis the Agent, hušæng in the example below:¹

(88) hušæng mærd æst.
Hushang is a man.

(For my interpretation of relations for the sentence in (88) above see 3.2.2).

The Function Level Verb (ALV, SLV, etc) is a new concept.² For example, ALV generally covers the type of verbs that traditionally have been marked as 'intransitive': verbs like ræftæn 'to go' were classified as instances of 'intransitivity'. Other levels include dichotomies like 'transitives' e.g. didæn 'to see', and 'ditransitives', e.g. dadæn 'to give'. This last, i.e. 'ditransitive', has not been attributed to Persian verb classification to my knowledge.

The problem that is created by the traditional 'transitive/intransitive' dichotomy is evident [cf. Khanlari 1970: 10ff.]. The functional load that should be proportionately and naturally distributed among the members of the three hierarchies had to be carried entirely by the 'transitive' verb, as the 'intransitives' could not be associated with 'objects' [for examples of such misinterpretations see Khanlari 1970: 10, 12-15]. The traditional criterion for Object was the postposition -ra attached to the nominal. There are no sentences of the type:

- (89) *həsæn miz-ra ræft.
*Hassan went the table.

However, there are sentences of the type:

- (90) həsæn æz-miyan ræft.
Hassan died.

in which æz-miyan 'lit. from the middle' is an example of the Source function. These sentences had to be treated adverbially.

The verb kærdæn 'to do' is a good example of the type of confusion created by the 'transitive / intransitive' dichotomy. Compare the following sentences:

- (91) a. mæn kærd-æm.
I did.
b. mæn kar-ra kærd-æm.
I did the work.
c. mæn kar-ra tæmam kærd-æm.
I finished the work.
d. mæn kar-ra tænha (be-tænha-i)
tæmam kærd-æm.
I finished the work by myself.

Once beyond the sentence in (91-b) one was not sure how to classify the functions (my terminology) attributable to the verb kærdæn.

In order to solve the problem of verb classification with-

out taking refuge in 'transitive/intransitive/ditransitive' distinctions which are mostly surface classifiers, this framework introduces the Verb Level concept in which each surface phenomenon is attributable to members of a hierarchy of functions and is, thus, open to deep structure interpretation according to the member of the hierarchy it associates with. According to this analysis although the sentences in (91) all have instances of kærdæn 'to do' on the surface, in the deep structure, each kærdæn is interpreted differently and according to the single or multiple functions it is associating with. I will give more details regarding this type of deep structure distinction later on (Appendix A) in my treatment of the traditional Persian compounds.

In chapter one, where I discussed the general outline of this grammar, I said that I exclude the study of the Lexicon and the Phonological component from this grammar. Although that statement still holds, below I intend to give the reader an example of the type of surfacing this framework uses for 'converting' deep structure into surface structure.

I have already shown how an Agent Level Sentence like

(92) hušæng ræft.

Hushang went.

is derived (see above page 83).

The rules through which this sentence was derived are:

(93) V U N → Agent
 [+Func.] [+Phys.]

Agent ∩ V → ALV #
 [+Func.]

(The sign # indicates that the rule is terminal and that no further function will follow from the Agent of this particular verb level.) The sentence that results from the above feature rule combinations is an ALS sentence. The result of the inherent rule-features producing this sentence is:

- (94) Agent V
 [+Phys.] [+Func.]

This structural description further is fully modified by the Lexical Component of the grammar. This component will add the following information regarding the lexical feature specification of each of the sentence components above. [[]] indicates lexical item.

- (95) N
 Agent
 [+Phys.]
 [[+Conc.]]
 [[+Hum.]]

The above specification shows that the nominal under discussion is Physical as opposed to Abstract, is Concrete as opposed to gaslike substances, and is Human. It can still be further specified as to whether the nominal is Mass or Count, in case it is Count; Singular or Plural. But here I will ignore these distinctions. This lower level of my analysis roughly corresponds to the deep structure analysis of Chafe [Chafe 1970].

The lexical specification for the verbal will be

- (96) V
 ALV
 [+Func.]
 [[+Act.
 - LC
 +3rd sing.]]

This specification indicates that the verbal under discussion is a Functional verb as opposed to adjective, is a verb of action and is specified by negative location code. (Location Code is the place where the speaker is producing this sentence.) Thus the ALS that is the output of this rule will be:

but not

- (99) a. *æli æz-hæsæn dad.
 b. *æli æz-hæsæn kærd.

The deep structure realization of the sentence in (98-b) will be given below.

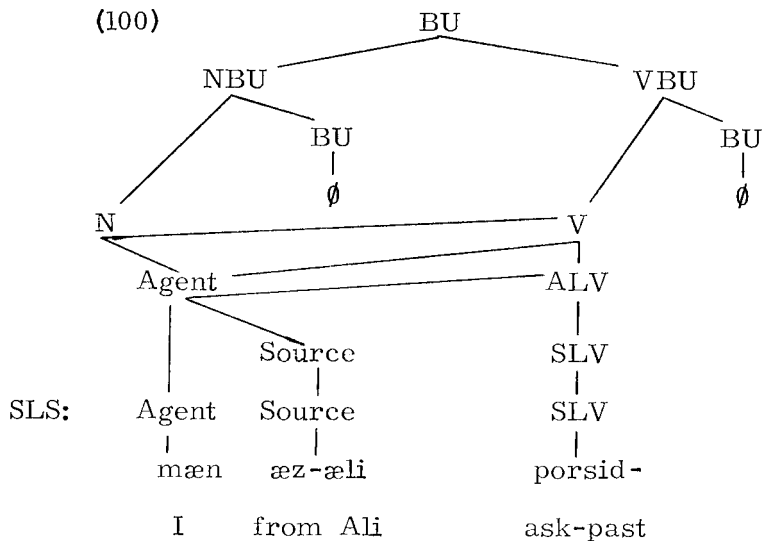

It is important to note that once the conceptualized primitives N and V, stripped of their BU, are 'converted' into function, they are realized on the surface only in that 'converted' form, namely the function they create. The functions, however, are the base for other functions, and are represented on the surface unless some verb levelling requirement deletes them.

The terminology Source is used by McCoy in terms of binary features (\pm) related to the Agent deep case [McCoy 1969: 71-74]. A similar concept is also developed by Nilsen reducing the productive elements to six hierarchically related deep cases [Nilsen 1971: 2, 44-52].

tion of the preposition'. Fillmore's definition of the Instrumental comes pretty close to the function Path of my framework, but Fillmore does not devise a system with the mapping power which makes this transitional function receptive to Instrumentality, and Commitativeness. However, he clearly indicates that the concept of 'causation' is directly involved with the Instrumental.

Other case grammarians like McCoy, Lambert and recently Nilsen, following Fillmore, have ignored Path as an independent case, but have implied its existence by suggesting wherever there are indications of Source and Goal cases, there has to be a Path. The treatment of all the cases they have introduced, in the light of their own theory, remains sketchy and in need of further explication.

The justification for the derivation of the Path and my reasons for keeping this function as an independent function is based on logical deductions. It is evident that the Agent who instigates an act to affect someone or something needs 'means' by which he can reach the Experiencer.

3.2.1.4 Experiencer Level Sentences

It was shown earlier that the Experiencer function is achieved by mapping the PLV into the Path. It is a function effected by the functional power of the Agent motivated by Source and through the intermediacy of Path.

Compare the following sentences:

- (105) a. hušæng košt.
Hushang killed.
- b. hušæng šir košt.
Hushang killed a lion.
- c. hušæng ba-kard šir košt.
Hushang killed a lion with a knife.
- d. mæn æz-xæšm ba-dæst šir-ra košt-æm.
I killed the lion by (my) hands out of anger.

The underlined forms in the sentences presented above.

are examples of the realization of the Experiencer function.

The deep structure realization of the sentence given in (105-b) is diagrammed below:

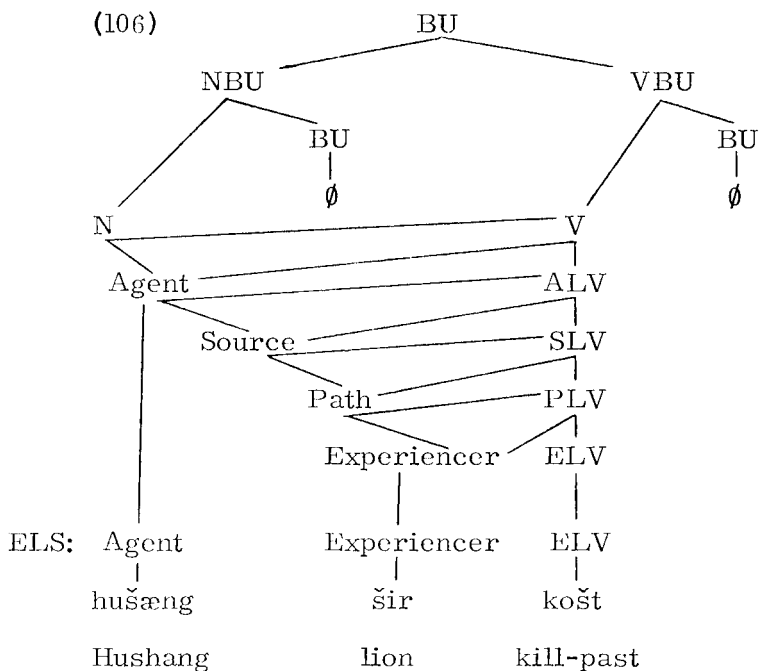

Compare this diagram with the diagram in (107) for (105-d) in which all the functions leading to the Experiencer are realized.

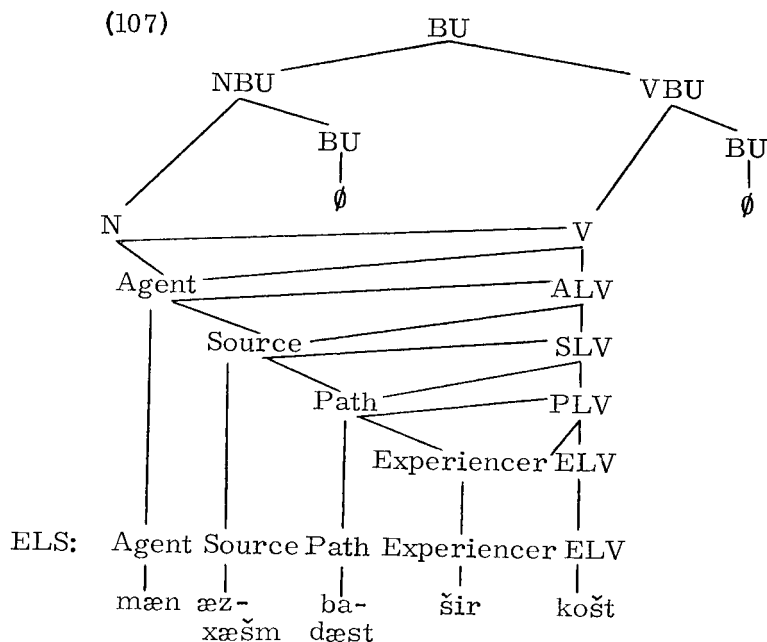

I from anger with hand lion kill-past

In the literature prior to Fillmore's case theory, there is no distinction between Experiencer and the Object. Both of these functions have been associated with 'objectivity'. For further discussion see below where the Object is discussed in detail.

3.2.1.5 Goal Level Sentences

It was shown above that the Goal function is derived by mapping the ELV into the Experiencer. This process is at the end of a transition from the Agent to the Experiencer. The function of the Agent will be 'perfected' in the Goal. Thus, the Agent and the Source on the upper level of the hierarchy of functions and the Experiencer and Goal on the

Source and vice versa. Thus if one wants to express the concept of Source-Goal relationship for function verbs, one has to express it within two simple sentences and then combine these two simple sentences by ultra-existent juxtaposition to achieve a complex sentence like:

- (111) hušæŋ æz-æli pul gereft (væ) be-mæn dad.
 Hushang took money from Ali
 and gave (it to) me.

The Goal function and its correlative which maps the Goal into the PLV result in the GLS sentences presented above. I will diagram the deep structure realization of the sentence in (112):

- (112) hušæŋ be-æli goft.

Hushang told Ali.

- (113)

BU

NBU

VBU

BU

BU

∅

∅

N

V

Agent

ALV

Source

SLV

Path

PLV

Exper.

ELV

Goal

GLV

GLS:

Agent

Source

Path

Exper.

Goal

GLV

hušæŋ

be-æli goft

Hushang

to Ali say-past

Traditionally the function Goal has been variously attributed to the relation of the verb and the 'indirect object', in ditransitive verbs. Scholars working with languages which were subject to the traditional Latin case classification usually attributed this function to the Dative of one type or another.

Later, with the introduction of case grammar, the function which this framework calls Goal was partially defined as the Dative; this is different, however, from the Dative concept of the Latin oriented grammarians who classified the elements purely according to their surface values.

Fillmore defined Dative as follows:

Dative (D), the case of the animate being affected by the state or action identified by the verb [Fillmore 1968: 25].

Recently, following McCoy, Nilsen made an analysis of the deep case in terms of deep features. He depended very heavily on Source and Goal cases, because he felt that they form the uppermost rank within a hierarchy of relations which within his framework also consisted Cause and Effect, Controller and Controlled respectively:

..., these paired relationships are hierarchically ordered in such a way that the Controller-Controlled relationship is a special kind of Cause-Effect relationship, which in turn is a special kind of Source-Goal relationship [Nilsen 1971: 2].

Thus, Nilsen speaks of the relationship between the Agent and the Instrument as well as the relation between the Instrument and the Patient (my Experiencer) only implicitly. He does not develop the type of detailed bipolar hierarchy that this framework creates to account for the linguistic functions. (See my Rule Dependency and Rule Government.)

function. This position will become more clear below where I explicate, in more detail, the conversion of deep structure realization of abstraction oriented sentences in terms of Feature Specification into surface forms, and later the compounds.

For examples of the realization of the Object Level Sentences (OLS) compare the following sentences:

- (115) a. hæsaen gæza xord.
Hassan ate food.
b. hæsaen yæx bæst.
Hassan froze.
c. hæsaen pul gereft.
Hassan took money.
d. hæsaen ab pašid.
Hassan sprinkled water.

When the correlative rule for the Object function is accomplished, namely as soon as the Object function is mapped back into the GLV we can derive the sentences presented above as examples of the OLS. The deep structure mechanism diagrammed below for the sentence in (115-b) illustrates the function pile up process that goes into the making of a deep structure verb level, although most of the levels of the verbs can be easily skipped. It is perfectly acceptable to say, for example,

- (116) a. hušæng æz-rudxane ba-cub gozær kærd.
Hushang crossed the river using
a piece of wood.
b. mæn æz-rudxane ba-cub be-æli komæk dad-æm.
I helped Ali from the river with
a piece of wood.

but not

- (117) a. *hušæng æz-rudxane ba-cub be-æli komæk
gereft.
b. *hušæng æz-rudxane ba-cub gozær gereft.

Below I will first derive the sentence in (115-a) for an illustration of the function Object and then will diagram the sentence in (116-b) in order to show the verb dadæn 'to give' as an example of fully functional verbs.

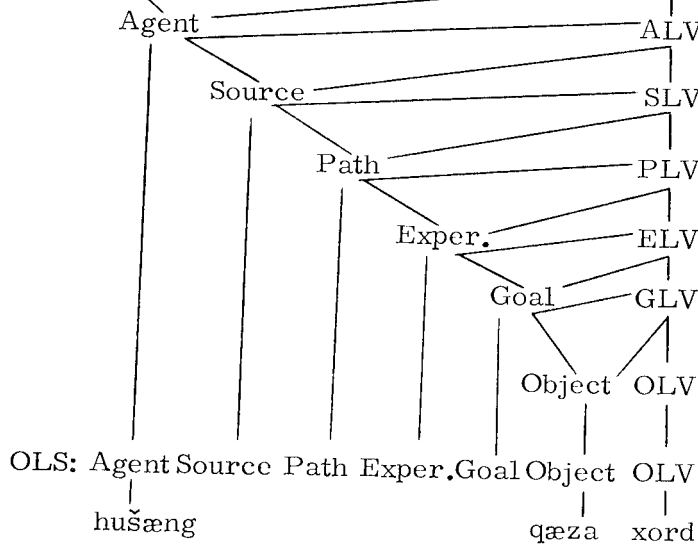
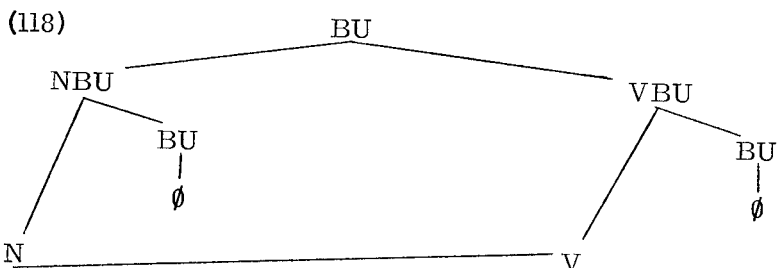

Hushang

food eat-past

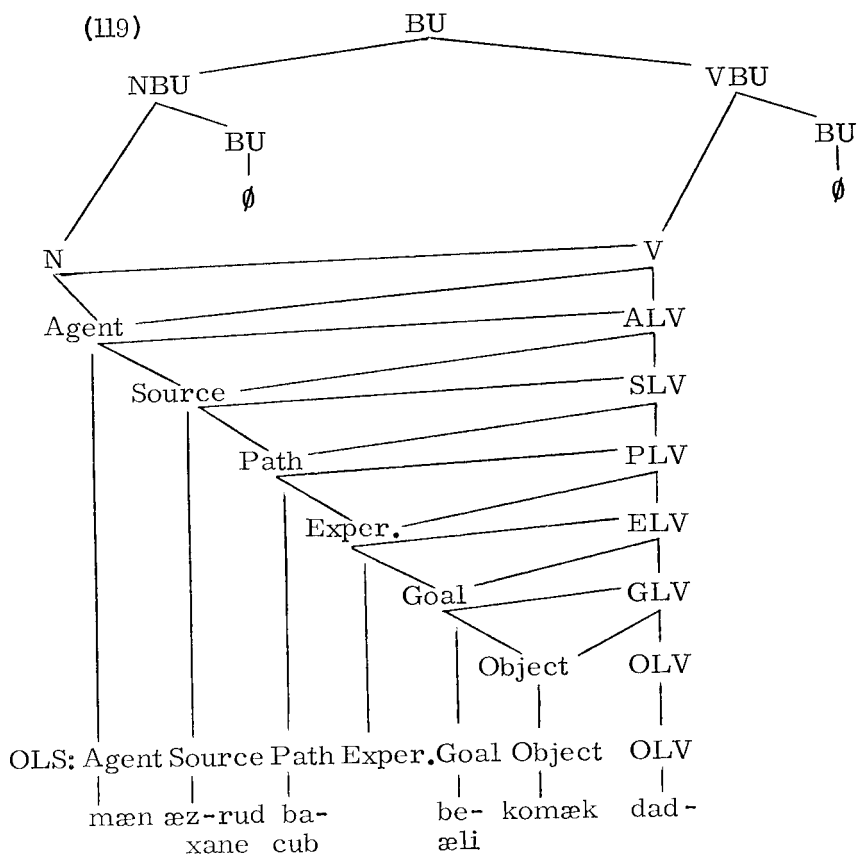

I from the river with wood to Ali help give-past

Traditionally, the terms 'accusative', 'direct object', and most recently 'objective' [Fillmore 1968: 25] have been used to identify this function. The most interesting and profitable of the definitions given is the one by Fillmore:

Objective (O), the semantically most

neutral case, the case of anything representable by a noun whose role in the action or state identified by the verb is identified by the semantic interpretation of the verb itself; conceivably the concept should be limited to things which are affected by the action or state identified by the verb. The term is not to be confused with the notion of direct object, nor with the name of the surface case synonymous with accusative [Fillmore 1968: 25].

Fillmore's definition of the 'Objective' like his definition of the 'Agentive', is well worth considering. However, it should be noted that Fillmore's definition suffers from lack of abstraction-function orientation on the one hand and introduction of the semantic component to help sort out verbs, on the other hand. I believe it is this same lack of abstraction-function level distinctions in his framework and consequently in his definition of the primitive functions that has forced Fillmore to label the Object case as the 'waste basket'. I am not claiming that my Object is not a 'waste basket'. But I assert that through the use of the Abstract, Abstract-Function Subsystems in my framework I am able to present a better knit 'waste basket' than Fillmore's.

3.2.2 Hierarchy of Abstractions

3.2.2.1 'To Be' as an Inchoative Base for Transformations

The Persian verb budæn 'to be' has been the topic of discussion of linguists from the time of William Jones [Jones 1771: 36-41] up until the modern times. A summary of their studies of this verb can be easily outlined and tabulated on one page showing the types of superficial irregularities with which these scholars have concerned themselves [e.g. see Bleek 1857; Phillott 1919; Lazard 1957; Jazayeri and Paper 1961; and Lambton 1967].

While there was not much theoretical justification behind setting up the paradigms indicating the superficial irregularities of budæn, the irregularities of the English verb 'to be' were attributed to 'higher degrees of regularity' [Chomsky 1957: 67-8].³ Further study of the verb 'to be' disclosed deeper insights into a paradoxical mechanism treated distinctly different by different transformationalists at different stages of the development of the theory.

Early generative transformationalists classified the verbs according to their 'behavior' in regard to the nominals (NP) they associated with. Thus 'to be' was classified as a verb distinct from the 'transitive' (V_{tr.}), the 'intransitive' (V_{intr.}), and later the 'ditransitive' (V_{ditr.}) verbs. 'To be' was classified as a 'stative' (V_{st.}) verb within a class of its own.

This method of treating verbs remained an 'accepted' method until the introduction of the Case theory concept of verb classification. The unique behavior of 'be' again resisted its classification according to the prescribed criteria of the Case theory for verb classification.

The confusion in the study of the 'Case' grammarians, on the 'be' issue, stemmed from the fact that according to Fillmore [1968: 21] no two instances of the same case could co-occur within the same simple sentence. For example, they could not assign the same case to both hæsæn and doktor 'doctor' in the following sentence:

(120) hæsæn doktor æst.

Hassan is a doctor.

The problem at issue, it seems to me, was not so much the assignment of similar or dissimilar 'cases' to hæsæn and doktor as it was the same lack of level distinctions that I have already referred to regarding the functionality or non-functionality of linguistic primitives. In fact, Fillmore's model tried to solve all the problems within a single level, a level roughly similar to my level of Functions.

In dealing with the passive, where 'to be' has both superficial and deep structure realization in English, Fillmore introduced 'to be' into the derivation by rules [Fillmore

1968: 38-40]. By doing so, he blocked the way to all possibilities of generation that could stem from 'to be' (see my treatment of passive through level transformation below).

Lakoff, on the other hand, looks at the problem from a generative angle and by producing the concept of the 'Inchoative' gives deep insights into this high level of analysis. Through his 'Inchoative' he can postulate a single deep structure for the verbs Become and Get and through the same 'Inchoative' he can delete the verb 'to be' [Lakoff 1970: 36-40]. The deletion of 'to be' at this stage is due to predictability, but the contribution to the theory is done through the postulation of the same deep structure for the verbs Become and Get.

My analysis systematically shows that the 'Inchoative' introduced by Lakoff has much deeper implications than the deletion of 'to be' or the assumption of common deep structure base for Become and Get. In fact, it asserts that the 'Inchoative' mechanism discussed by Lakoff should have 'to be' as its base. Then, as I will show presently, there will be easier and more economic ways for handling the factive, the causative, the passive and the active sentences through a similar system only at different levels (details follow). By thus modifying Lakoff's concept of the 'Inchoative' the minor rules that Lakoff has set up for forms which are 'rare' in English but 'common in other Indo-European languages' *will be classified as different realizations (transformed, that is) of the abstract instead of exceptions to major rules* [cf. Lakoff 1970: 40].

3.2.2.1.1 Transformations Within the Level

I have already presented the rules and rule-features according to which the Hierarchy of Abstraction of the Hypersystem is derived [see 3.2.2 above]. Now I assert that this level of the Hypersystem will exclusively include 'to be' and its lexically modified transforms. The sentences on this level are either of 'equational' or of 'modification' types. Compare the following sentences:

- (121) a. mærg bi-ræhm æst.
Death is cruel.
b. zendegi širin æst.
Life is sweet.
c. servæt bəray-e zendegi xub æst.
Wealth is good for living.
d. servæt ba'es-e saman-e zendegi æst.
Wealth is the source of organization in life.

[For more information regarding causativity of (121-d) see Residual Problems below.]

I claim that in the deep structure all the sentences in (121) are examples of budæn sentences on the Abstract level [for a similar view cf. Li 1972: 573 ff.]. In the case of (121-c) and (121-d) we have transformed sentences with varying degrees of abstraction depending on Causation and Benefactive aspects. Note that in (121-c), for example, servæt 'wealth' is not used in concreto. It is a lexical transform of yet another abstract as well as function oriented form pul 'money'.

For further distinction between pul 'money' as a Functional unit compare (122-a) with (122-b) below:

- (122) a. pul xub æst.
Money is good.
b. u be-mæn pul dad.
He gave me (some) money.

In the example above pul in (122-a) is not used in concreto. xub 'good' is an Object level Nonfunctional Slot which should be treated adverbially.⁴ pul in (122-b), however, is a Physical Object transferred from an Agent (u 'he') to a receiver or Goal (be-mæn 'to me'). The deep structure of (122-a) is presented below:

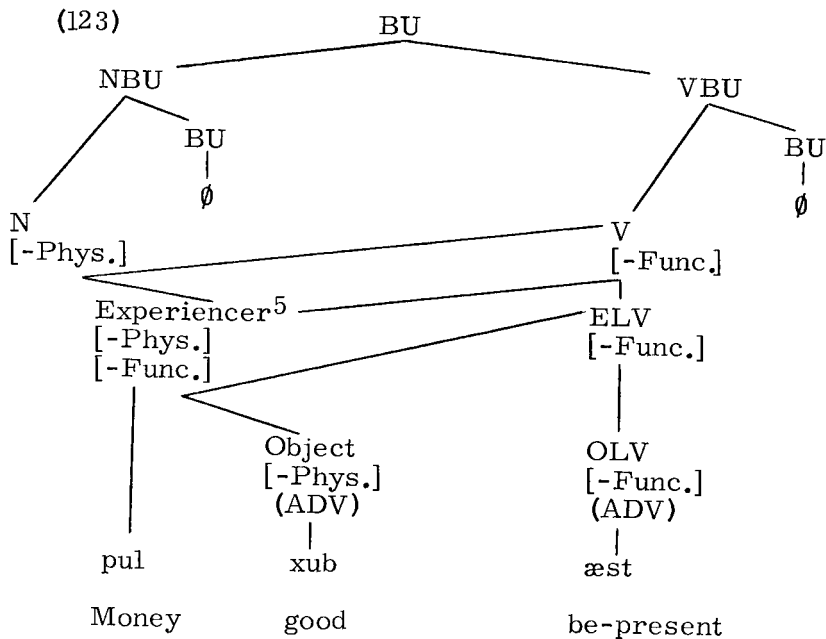

Now compare the diagram in (123) with the following diagram in (125) representing the following sentence:

(124) servæt xub æst.
Wealth is good.

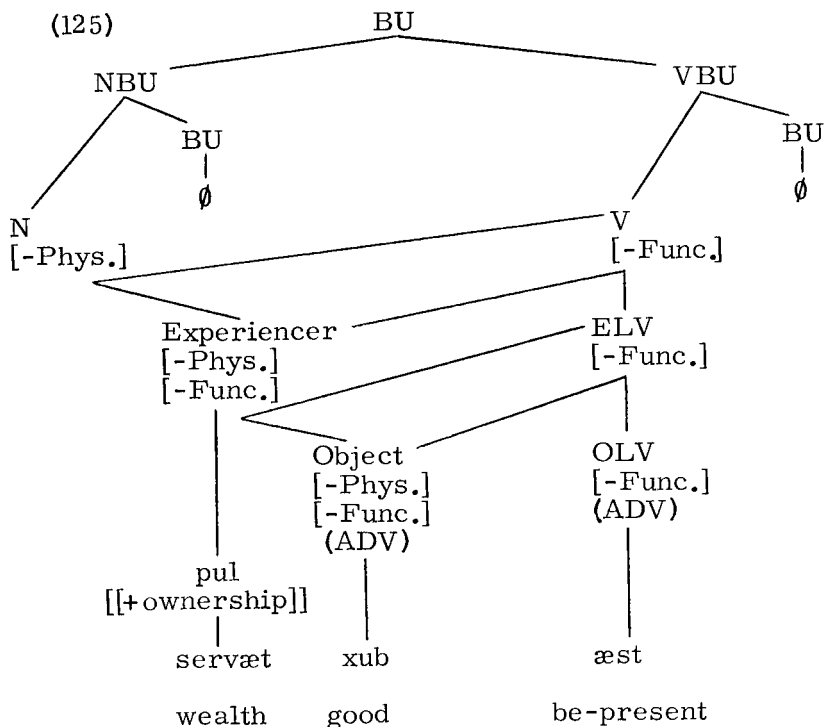

Thus, I claim that the difference between the two sentences is a presurface lexical distinction. In the deep structure they are both derived at the same level, namely the level of Abstractions of the Hypersystem.

3.2.3 The 'Mixed' Hierarchy

'Case' grammarians changed the criteria for verb classification from 'overt' NP[^]VP relations of the type 'transitive', 'intransitive' and 'stative' used by generativists to 'covert' or deep structure 'actor-action' relations. The details of the classification and definite criteria for this type of classification were never spelled out. For example, according to Fillmore the Persian verbs didæn 'to see' and danestæn 'to know' would have the following case frames:

(126) didæn (+[— O + D])⁶

danestæn (+[— O + D])

[Fillmore 1968: 31]

This type of classification had considerable shortcomings. To begin with it dealt with the problem in terms of a unilevel analysis, and furthermore, it did not consider inherent features like Physicality (for nouns) and functionality (for verbs) and lack of these features significant for verbal classification.

Lakoff took these features into consideration. He hypothesized that 'Surprise' and 'Amuse', for example, took abstract subjects and animate objects, but later discovered that they took animate subjects and abstract objects in the deep structure [Lakoff 1970: 145]. He further indicated that 'Precede', 'Follow', etc. take both abstract subjects and abstract objects [Lakoff 1970: 146].

I confirm Lakoff's views regarding abstract Object in relation to Surprise and Amuse, but I assert that Animate-ness is an automatic consequence of Functional Levels with budæn 'be' and cannot be in any way associated with the deep structure Agent (Lakoff's Subject) of a sentence on the abstract level. Here we are dealing with 'animated' abstractions being related through budæn. There are, however, Surprise and Amuse univocals that deal exclusively with Function verbs, e. g.

(127) kudæk-ra ba-cubsigar særgærm kærd-æm.

I amused the child with the
cigarette holder.

where kærdæn 'to do' is a levelled transform variety of budæn within the Function level rather than within the Abstract level. There we can say that we have an animate Subject or Agent (cf. diagram 134, page 111 below).

My position regarding the other set, namely Precede and Follow, is that they should be treated as Object/Verb cases and be derived according to the regular derivation of kærdæn and oftadæn, the simple verbs which appear on

the Object level of sentences like:

- (128) A E O V
 mæn u-ra tæ'qib kærd-æm
 I followed him.

(Note that u-ra is an uneffected Experiencer on the 'Mixed' level of the Hypersystem.)

Regarding unidirectional⁷ verbs like didæn 'to see' and danestæn 'to know' I present the following analysis. I claim that, while the Agents of these sentences are Functional, the Experiencer is uneffected, thus regarded as Nonfunctional. Consider the following sentence:

- (129) hušæng mina-ra did.
 Hushang saw Mina.

The deep structure realization of this sentence is diagrammed below:

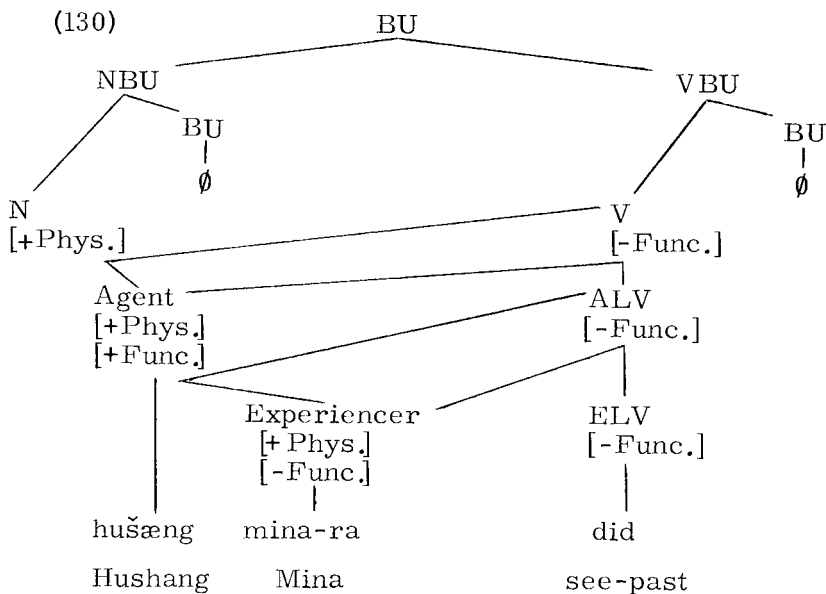

The sentence in (131) below will have a similar deep structure:

(131) mæn pæri-ra gereft-æm.
I married Pari.

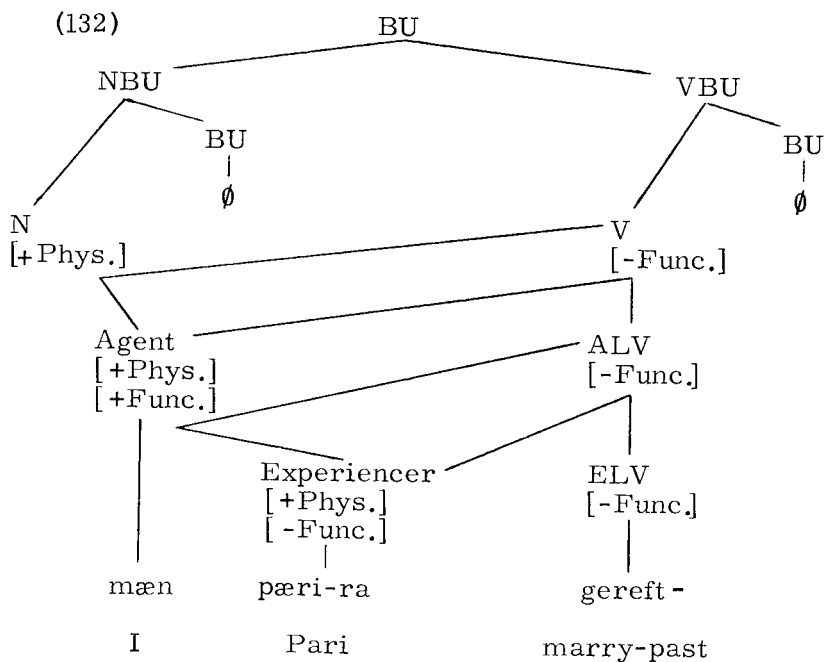

There are also sentences in which a Functional verbis coupled with a Nonphysical, Nonfunctional function slot. For instance consider the following sentence:

(133) 'ešq mord.
Love died.

This sentence is diagrammed below:

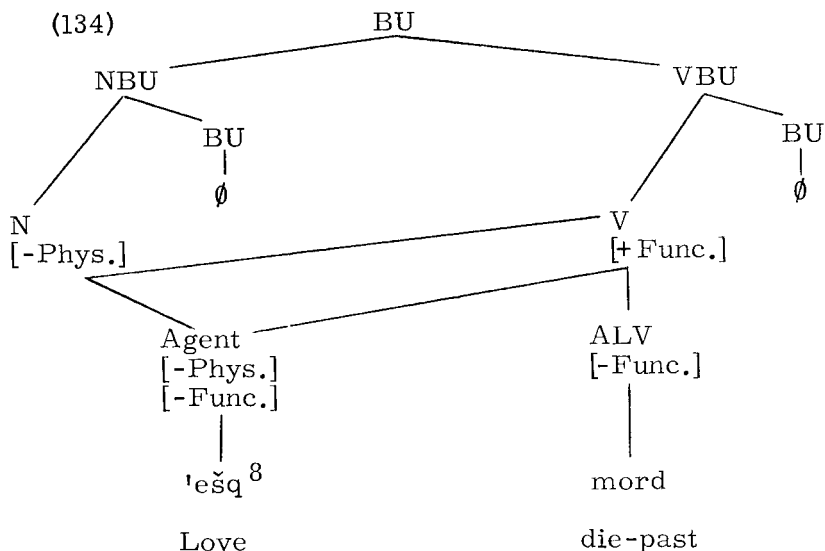

3.3 Transformations within the Hypersystem

I have already indicated that there are possibilities for lexically based transformations within each of the Subsystems of the Hypersystem. There I showed how the Abstract Subsystem, for example, could modify its function slots without significant change in the nature of the level itself (see 3.2.2.1.1). Now I assert that *there are possibilities of transformations across the levels of the Hypersystem*.

Namely, it is possible to postulate a budæn matrix for the whole Hypersystem and draw different 'types' of transformed budæn-sentences depending on the level to which this matrix is 'translated'. This is equal to the Inchoative of Lakoff but is more powerful, that is, it has more generative power and more economic possibilities for explicating factive, causative, passive and active structures within a coherent system. Compare the following sentences:

- (135) a. mæn æz-fulad hæst-æm.
I am (made of) steel.

- b. *mæn æz-fulad šod-æm.
 c. *mæn æz-fulad kærd-æm.
- a'. *mæn æz-tærs ba-nefræt mærg-ra qorban
 bud-æm.
 b'. mæn æz-tærs ba-nefræt mærg-ra qorban
 šod-æm.
 Out of fear and with hate I
 extolled death.
- c'. *mæn æz-tærs ba-nefræt mærg-ra qorban
 kærd-æm.
- a''. *mæn æz-kuh ba-dæst sæng-ra pærtab
 bud-æm.
 b''. *mæn æz-kuh ba-dæst sæng-ra pærtab
 šod-æm.
 c''. mæn æz-kuh ba-dæst sæng-ra pærtab
 kærd-æm.
 I threw the stone from the
 mountain using my hand.

The pattern that emerges from the comparison of the sentences above and many similar Persian sentences is presented in the chart that follows:

	ALV	SLV	PLV	ELV	GLV	OLV
budæn	-	-	-	+	-	+
šodæn	+	+	+	+	-	+
kærdæn	+	+	+	+	-	+

Figure 2
 The budæn Matrix

The restriction on the levels of the chart should be specified. None of the levels containing the verbs overlap. All levels are mutually exclusive which proves that all three

levels of the chart can be derived from a common 'matrix' in terms of the levels involved.⁹

Now compare this chart with the chart below where the Hypersystem is reproduced:

	ALV	SLV	PLV	ELV	GLV	OLV
Abstr. Subs.						
Mixed Subs.						
Func. Subs.						

Figure 3
The Hypersystem Matrix

When the chart produced for the verbs budæn, šodæn, and kærdæn is superimposed on the chart showing the internal structuring of the Hypersystem we will have:

	ALV	SLV	PLV	ELV	GLV	OLV
budæn 'be' Abstr. Subs.	-	-	-	+	-	+
šodæn 'become' Mixed Subs.	+	+	+	+	-	+
kærdæn 'do' Func. Subs.	+	+	+	+	-	+

Figure 4
budæn and the Hypersystem

This analysis shows that kærdæn is basically a function verb. However, it can pattern with nonfunctional verbs if the nominals that associate with it at verb levels are non-functional. Thus, for kærdæn to be a fully functional verb it is necessary that the nominals that associate with it at

different levels have the feature specification [+ Phys.]. In
 [+ Func.]

that case kærdæn will not pattern with verbs like šodæn as far as its functionality is concerned. For further information on the behavior of kærdæn in regard to Levels see Appendix A where the problem of compounds is discussed.

The participation or lack of participation of each of the slots in the production of sentences plays an important role in verb classification. For example, lack of participation of the GLV slot in the creation of the verbs cited above marks a distinction between these verbs and the verb bordæn 'to carry', for example. This will give sentences of the type

- (136) mæn æz-tærs ba-pæšimani be-xoda pænah
 bord-æm. Out of fear and with remorse
 I took refuge in God.

But I would rather leave further discussion of verb classification for a later time. It needs much more time and precision than I can afford here.

The conclusion of this section, namely the possibility of transformation across the Subsystems of the Hypersystem is summarized in the chart below:

Levels	budæn
Abst. Subs.	budæn 'to be'
Mixed Subs.	šodæn 'to become'
Func. Subs.	kærdæn 'to do'

Figure 5
 Summary Matrix¹⁰

¹In The Case for Case Fillmore asserts: 'each case relationship occurs only once in a simple sentence' [Fillmore 1968: 21]. He further argues 'whenever more than one case form [presumably of the same type] appears in the surface structure of the same sentence (on different noun phrases), either more than one deep structure case is involved or the sentence is complex' [Ibid.: 21].

²A strikingly similar concept of level is contributed to the study of semantics by Weinreich [Weinreich 1966], and is later followed by McCawley [McCawley 1968: 126]. For instance, regarding the interpretation of the adjective 'sad' in the sentence:

*John is as sad as the book he read yesterday.

McCawley says:

If different readings associated with the same phonological shape are considered to be different lexical items, the problem is immediately solved. There are then two different lexical items: sad₁, meaning 'experiencing sadness, said of a living being', and sad₂, meaning 'evoking sadness, said of an esthetic object' [my italics, Ibid.: 126 ff.].

My analysis of the Persian verbs shows a similar pattern.

Regarding verbs Fillmore's position, however, is paradoxical, namely while he believes that verbs can, and do take n-place predicates and stresses the fact that this information can be used as criteria for verb classification, he totally ignores the correspondence of 'arguments' and the 'predicates' in the deep structure. Thus he asserts:

Two verbs can differ in that one manifests an n-place predicate and the other manifests an m-place predicate, the roles of the arguments that are present in the one and absent in the other accounting for the differences in the semantic interpretation of the sentences which contain them [Fillmore 1970: 42].

The reason for restricting this type of breakdown of the verb, as he explains later on, is due to the fact that Fillmore's framework does not allow n-place predicates to take two or more identical 'roles'. This restriction, however, has been proven irrelevant [e. g. by Nilsen 1971 and references therein] and by the level distinctions of this framework.

Curiously enough, nevertheless, we do find Fillmore discuss-

ing 'the "transitive" form of MEET', etc. [Fillmore 1970: 46]. The concept of verb levels of this framework is no more than a formalistic approach to ad hoc references to distinct deep structure realizations of verbs.

³In Chapter One, I discussed Chomsky's view regarding the regularity of the verbs 'have' and 'be'. Below he discusses another insightful notion, namely the status of 'be' and 'have' in relation to transformational rules:

If we were to attempt to describe English syntax wholly in terms of phrase structure, the forms with "be" and "have" would appear as glaring and distinct exceptions. But we have just seen that exactly these apparently exceptional forms result automatically from the simple grammar constructed to account for the regular cases. Hence, *this behavior of "be" and "have" actually turns out to be an instance of deeper underlying regularity when we consider English structure from the point of view of transformational analysis* [my italics, Chomsky 1957: 67-68].

It should, nevertheless, be noted that Chomsky makes a distinction between phrase structure (PS) rules and transformational (T) rules. This framework combines the two.

⁴This framework distinguishes between several categories of adverbs: for instance, adverbs which would allow explanation by the system and adverbs which do not allow explanation by the system. Thus, Source and Goal can be both temporally and spatially explained by the system while Agency does not involve adverbiality. This statement is formally represented below:

Functions		A	S	P	E	G	O
Adverb	Temp.	-	+	-	-	+	+
	Spat.	-	+	-	-	+	+

⁵For reasons for my calling this function slot Experiencer rather than Agent see Factive sentences in 4.2.4, below.

⁶Fillmore would specify that the verbs didgen 'to see' and danest-an 'to know' both have an Object as well as a Dative in their case frames. Compare the following sentences:

- | | | | |
|----|----------|----------|-------------|
| | <u>D</u> | <u>V</u> | <u>O</u> |
| a. | Hans | saw | the clock. |
| b. | Hans | knew | the answer. |

where, in both instances, we have Hans as a Dative, 'the clock', and 'the answer' as Object.

⁷Unidirectional verbs are those verbs the result of which does not directly affect the Experiencer or Object. In a way they begin and end with the Agent. However, they might ultimately affect an Experiencer as, for example, in the case of residæn 'to reach'.

⁸ešq here can be understood as the nominalized transform of a sentence like:

- u 'ašeq æst.
He loves (is in love).

⁹However, this adherence to Function level should not be confused with choice of nominals from other levels which results in patterning kærdæn with the verbs of the 'Mixed' level. For more details see the treatment of the compounds in Appendix A below.

¹⁰It is interesting to note that the Summary Matrix arrived at on independent grounds and through the analysis of a different language than the English language, should bear the same type of 'atomic predicate'. However, certain crucial differences have to be taken into account.

The framework developed here in this study does not believe in Lakoff's basic assumption, namely the notion of irregularity in syntax; conversely, it supports Chomsky's notion of regularities on higher and more abstract levels of grammar which are totally ignored by Lakoff's unilevel analysis.

The system proposed here is not the ad hoc results of attempts 'to patch up a classical theory' [to use Lakoff's own terms, Lakoff 1970a: 1], rather it is a coherent unified system for which Lakoff's 'atomic predicate' has been an automatic consequence of the application of its basic rules and transformations across the levels of its Hypersystem.

Let us examine the sentences presented by Lakoff in Irregularity in Syntax

- a. The sauce is thick.
- b. The sauce thickened.
- c. John thickened the sauce. [Lakoff 1970: 43, cf. also Dowty 1971: 13].

The solution that I propose for the common base or Inchoative base from which these sentences are derived has nothing to do with their morphological and semantic similarities, rather it deals with them in terms of the TMCM rules that convert the NS through the FSS into these three basic realizations of the Hypersystem. From this background only, the semantic, but not necessarily mor-

phological similarities arise, and it is due to the regularity of the transformational rules producing these relations that this framework claims more explanatory power.

The problem posed by Lakoff can be easily solved. Translated into my deep structure these sentences will read:

- | | | | | |
|----|-------------------------------------|--------------------------------|-----------------------------|----------------|
| a. | Experiencer
[-Phys.]
[-Func.] | Object
[-Phys.]
[-Func.] | OLV
[-Func.] | Abstract Level |
| b. | Agent
[+Phys.] | ALV
[-Func.] | | 'Mixed' Level |
| c. | Agent
[+Phys.]
[+Func.] | Object
[+Phys.]
[+Func.] | OLV
[+Func.]
[+Func.] | Function Level |

As can be easily seen the three sentences above are only part of the core sentences that can be derived from the Summary Matrix above on page 114. (For further detail see Residual Problems in Chapter Four below.)

Chapter Four

RESIDUAL PROBLEMS

4.1 Introduction

In this chapter two major points of syntax, namely sentences across the levels of the Hypersystem and clause expansions are dealt with. These are aspects of syntax that have typically drawn the attention of the theoretical linguist. The solutions offered by various theories have partially solved the problem, although each theory has created other problems of its own. The problems mentioned are not by any means language specific. On the contrary, they are parts of the problems of the general theory of syntax. *It seems, however, that my solutions to these problems are different from those offered so far.*

In the light of the theory explained in the previous chapters, I will prove that each of these problems can find better solutions through the system outlined above than through the systems so far expounded through English.

The treatment of none of the problems will be exhaustive. The aim of this chapter is the identification of the problems involved and administration of general rules for solving those problems. In fact, each one of the problems referred to in this chapter can be regarded as promising subjects for further extensive linguistic discussion and research. The theoretical framework that I have proposed can solve and detail these problems through devices which are specially built in it for the analysis of such linguistic structures. The universality of these devices can easily be tested on languages with similar problems.

4.2 Sentences Across the Levels of the Hypersystem4.2.1 Preliminary Observations

In the following I will demonstrate the explanatory power of this model. I will show that the interrelationship of certain types of sentences is easily explained by specific types of level switch transformations. The sentence types under consideration are: the Active, the Passive, the Factive and what I call 'Causative'.

Active and passive need no comment. Factive sentences are those sentences marked by budæn; they describe the result of an action. In these sentences all relations are described in terms of deep structure causation,¹ as in

- (137) u košændey-e hušæng æst.
He is the cause of Hushang's death.

As an example of the sequence of sentence types presented above I would like to discuss the following sentences:

Sentence type	Sentence
Active	u hušæng-ra košt. He killed Hushang
Passive	bevæsiley-e u hušæng košt-e šod. Hushang was killed by him.
Factive	hušæng košt-e æst. Hushang is killed.
Causative	u košændey-e hušæng æst. He is the cause of Hushang's death. (He is Hushang's killer.)

Figure 6
Sentence Types

4.2.2 Active Sentences

All our examples so far have been active sentences. Thus, their description here would be repetitive.

4.2.3 Passive Sentences

Below I will discuss this problem in the light of the traditional approach as well as the more recent theories: the generative transformational approach will be discussed in relation to the structuralist method of interpreting the Persian passive, while the generative transformational will examine the application of Chomsky's Aspects model to these constructions. There is no published application of case grammar to the Persian passive. Therefore, I will discuss Fillmore's solution to the problem of passive constructions of English. This will give the reader a better point of reference for comparing my solution to the problem and observe its advantages over any one of the above mentioned theoretical approaches.

4.2.3.1 The Structuralist Approach

The structuralist school made a distinction between the so-called 'transitive' and 'intransitive' verbs. It suggested that only the verbs which are subcategorized as 'transitive' verbs can have a passive form provided they use the participle and the 'auxiliary' šodæn 'to become' to reflect the inflected forms for all tenses and persons [see Jazayeri and Paper 1961: 191 ff., and Lazard 1957: 152 ff.].

Consider the following example:

- (138) hušəng-ra did-ænd.
They saw Hushang.

The sentence cited above is generally passivized by the omission of the Agent and periphrastic verbal form built of the past participle did-e and the auxiliary šodæn 'to become'.²

The structuralists, however, do not discuss the cases that I call factive and causative at all and thus ignore their relationship to active and passive sentences.

4.2.3.2 Generative Transformational Approach

The transformational generative approach was suggested by Moyne who applied Chomsky's model as it is explained in Aspects. He explains all so-called passives as containing a superordinated impersonal clause with the meaning 'it happened' or 'it became', or more abstractly, 'PASSIVE', and through a derivational (embedding) process attaches PASSIVE to the verbal form of the subordinate clause. Below I will reproduce his diagram [Moyne 1970: 221] that represents his derivational 'history' for the Persian sentence hušæng dida šod 'Hushang was seen' (his transcription).

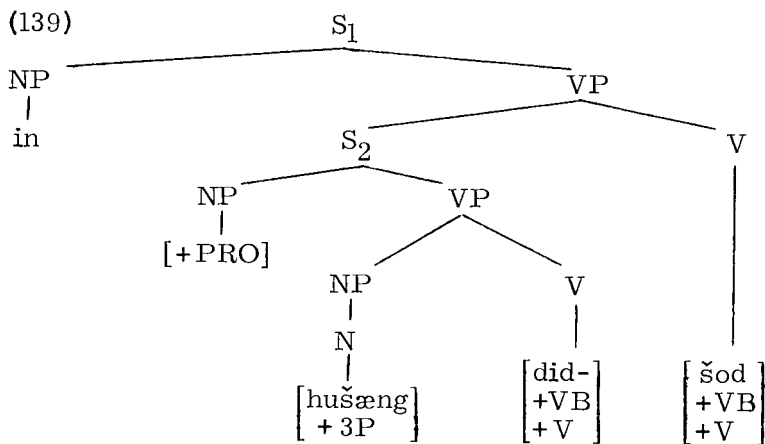

That is, in order to derive passive in Persian he has to create a superordinated fictitious in šod 'this happened' as well as a [+PRO]-noun-phrase which is to indicate the (obligatorily) unrealized agent of the passive clause. His assumption necessitates the application of rather elaborate rules all serving to eliminate the superordinate clause and the agent-dummy [+PRO]; (rules like 'object preposing, subject raising, participle formation, and copying rules'.)

Again, it is evident that Moyne did not note the correlation of the four sentence types under discussion.

4.2.3.3 The Case Theory Approach

In his grammar Fillmore handles passive through a particular subject-raising mechanism. Let us consider the passivization of the verb 'Give' in his framework. In that framework 'Give' has the following case feature frame:

(140) Give [— O D A]

For example, in the sentence:

(141) John gave the books to my brother.

'John' is the Agent (A), 'my brother' is the Dative (D) and 'books' is the Object (O). The relations are diagrammed after subject raising.

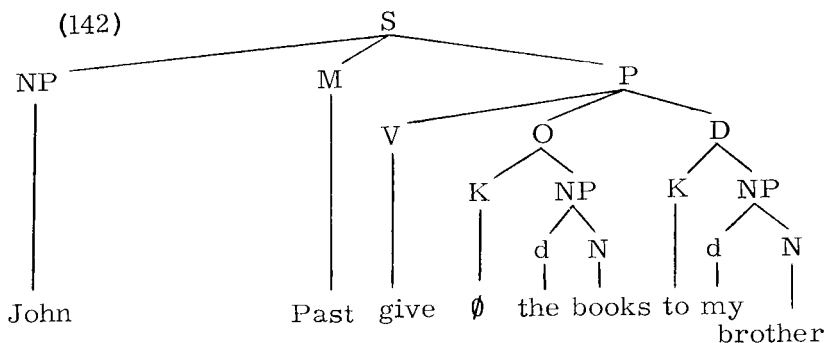

'Give' is one of the verbs that allow the raising of either the Dative or the Object to surface subject position. Below the Object is raised to Subject position.

ledge, a mechanism that would relate passive sentences to Factive and Causative sentences. It seems, therefore, like Moyne who explains passive by superordinated sentences, Fillmore, too, has to go 'outside' the deep structure nucleus of the sentence for deriving and explaining passive.

4.2.3.4 My Approach

In my system passive sentences are an automatic consequence of budæn sentences on the 'Mixed' level of the Hypersystem. Consider the following sentence:

- (145) æli hušæng-ra košt.
Ali killed Hushang.

This active sentence is diagrammed below:

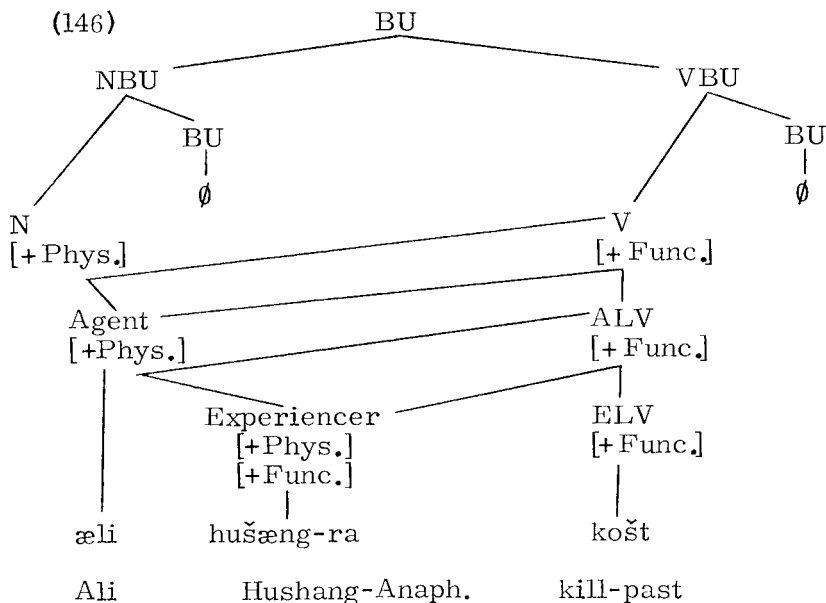

The passive form of this sentence is:

- (147) (bevæsiley-e æli) hušæng košt-e šod.
 Hushang was killed (by Ali).³

The deep structure of this passive sentence is given below:

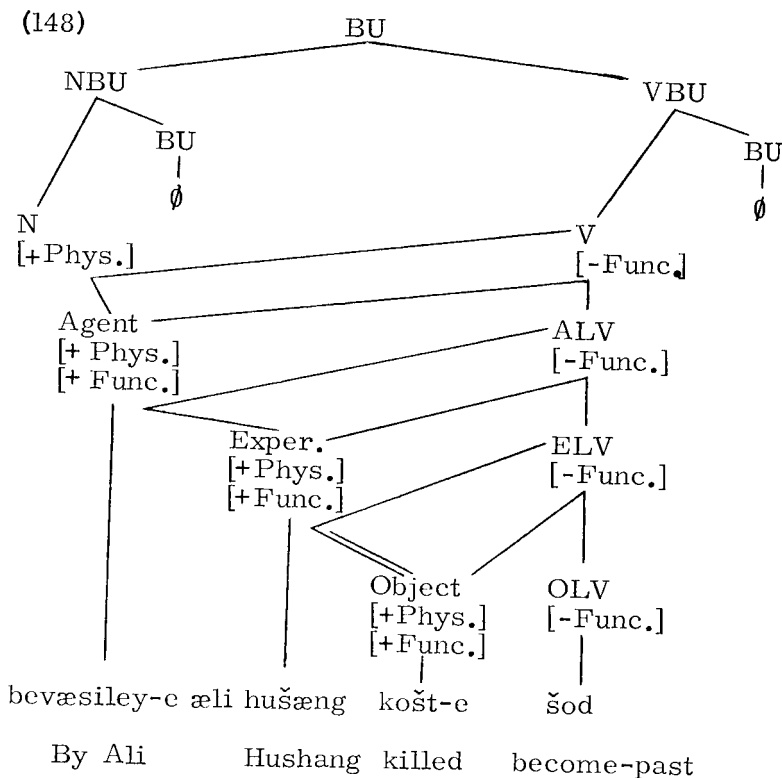

An important process takes place in my way of handling the passive. It is the switch of the verb to the position of a participial Object with the obligatory rule of Experencer-Object identity.⁴ On the other hand, the auxiliary budæn is automatically coupled with the verb šodæn--a direct consequence of budæn matrix outlined earlier (see page 113, more details will follow). This interpretation also makes the relation between the passive sentences and

so-called predicative sentences of the type presented in (151) clear.

(149) hušəng xis šod.
Hushang became wet.

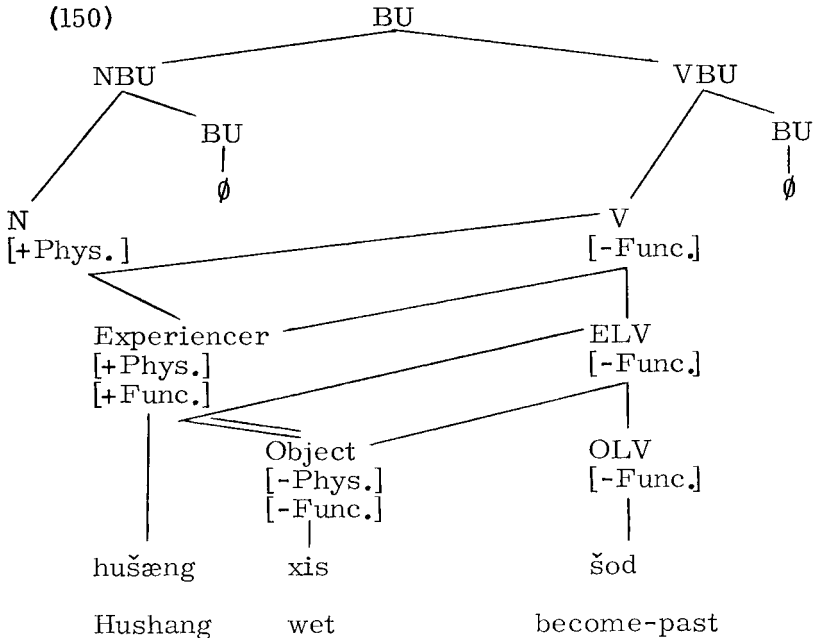

Evidently, my derivation of the passive has certain resemblances to both the generative transformational and the case grammar approaches. In generative transformational grammar passive is a superordinated clause with an impersonal Agent. In my system passive is derived from a deep structure VBU component in constant correlation with the Agent and the Experiencer. In case grammar Passive is separated from the 'frame' sentence and is attached to the modality part where it should not belong. In my system there is no necessity, whatsoever, to involve modality in the deep structure base component. Passive is

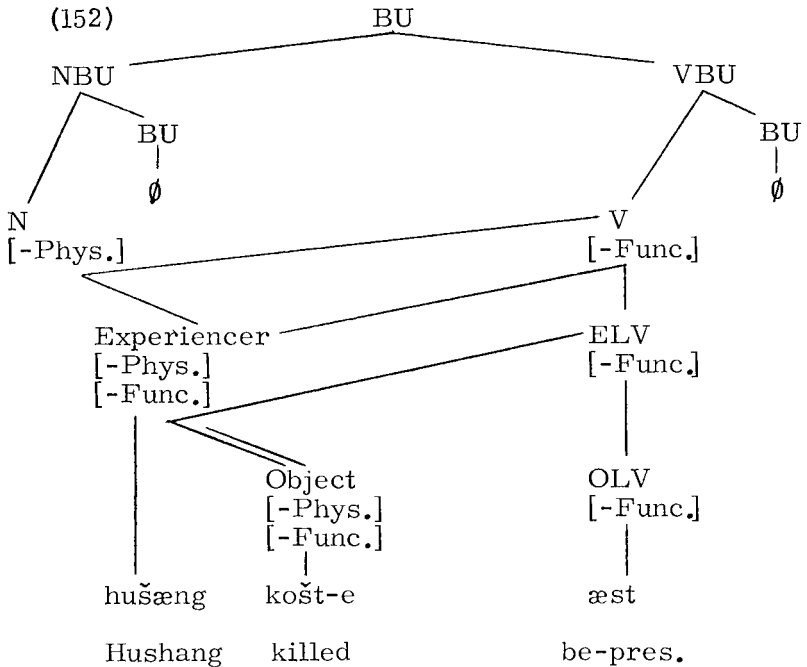

Any attempt at Agent creation at this level will require Source and consequently Causation (see below). The Experiencer and Object of factive sentences undergo an obligatory identity rule similar to the Experiencer and Object of the passive (see 3.2.3.4 above), this latter on the 'mixed' level, however.

4.2.5 Causative Sentences

Lakoff and, following him, Stilo treat causative and Inchoatives as main verbs which demand embedded sentences [see Lakoff 1970; and Stilo 1971: 50]. In their analysis, therefore, Causative and Inchoative figure as verb types. For example, the following is a sample entry for each type of verb given by Stilo for Vafsi-Tati:

(153)

<u>hor</u>	/+V	*MOM *ACT *PAST *PERF/	"to eat"
<u>sokk</u>	/+V	+ ADJ *MON *ACT *PAST *PERF/	"to be light"
<u>go</u>	/+V	+ MOD/	"to have to, must"
<u>na</u>	/+V	+ MOD + NEG/	"negative"
CAUS.	/+V	+ CAUS/	"causative"
INCHO.	/+V	+ INCHO/	"inchoative"

[Stilo 1971: 51].

I assert that Causation is an automatic consequence of Agent raising within the Abstract level of the Hypersystem. Compare the following sentences in Figure 7.

F	A V ⁶ u košt.	He killed.	Active
M	E O V u košt-e šod.	He was killed.	Passive
A	E O V u košt-e æst.	He is killed.	Factive
A	A S V u koš-æn-de æst.	He is killer.	Causative

Figure 7

Instances of Transformation Across Levels

when analyzed the following chart will emerge.

(—) indicates slot identity:

level	A	S	P	E	G	O	Sentence Type
F	+						Active
M				+		+	Passive
A				+		+	Factive
	+	+					Causative

Figure 8
Function Slot Identity
Across Levels

Thus, the Abstract Subsystem is responsible for two types of sentences: the Factive and the Causative. Of the two only the Causative is Agent-relevant. As an example of causative relations the deep structure of the sentence in (154) will be given below:

- (154) u koš-ænd-ey-e hušang æst.
He is Hushang's killer.

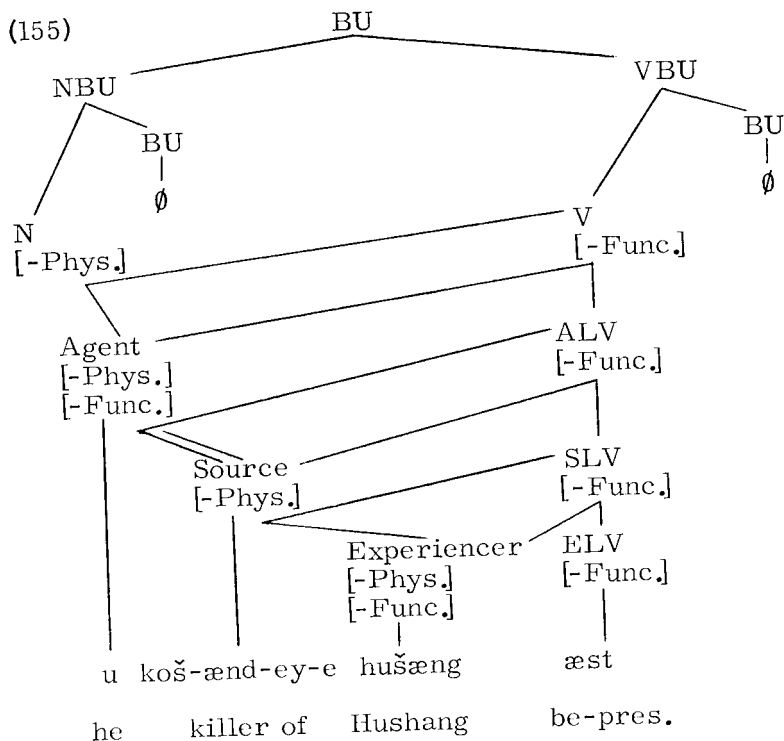

4.3 Clause Expansion

The most extensive study of the clause types of Persian can be found in Phillott's Higher Persian Grammar [Phillott 1919: 545-576]. The most systematic study, however, is presented in the structuralist literature by Lazard [Lazard 1957: 211-238]. Both approaches considered surface structure classification [see also Seiler 1960 for clause types and their classification].

With the advent of generative and case grammars the treatment of clause structures was identified with the recursive nature of rules and came to be handled through embedding sentences into matrix or main strings. One such application is found in the work of Moyne who applied

Chomsky's Aspects to Persian. Consider the following sentence:

- (156) *mixāham (ke) beravi*
 man *mixāham ke to beravi.*
 I want that you go.
 'I want you to go' [Moyne 1970: 222, his transcription].

Below I will reproduce the deep structure realization which Moyne assigns to this sentence:

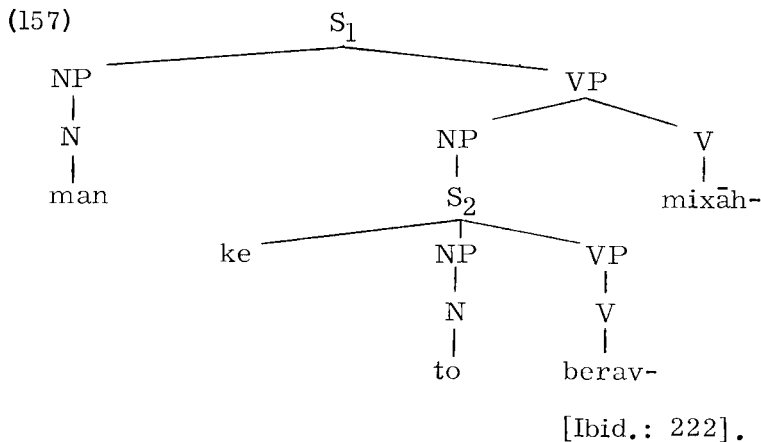

In order to derive the subordinate clause Moyne has to create an NP phrase first and allow for the possibility of subordinating that NP by a clause, i.e. S_2 . This is well in line with transformational generative distinction of such clauses as complement clauses, i.e. it-clauses.

My system has no need for such a complicated process. Following the very early rule of recursive BU-expansion, the subordinate clause is directly derived out of the BU component of the VBU as shown in the following diagram for the sentence in (158):

- (158) *mæn mi-xah-æm (ke) to be-ræv-i.*
 I want you to go.

(159)

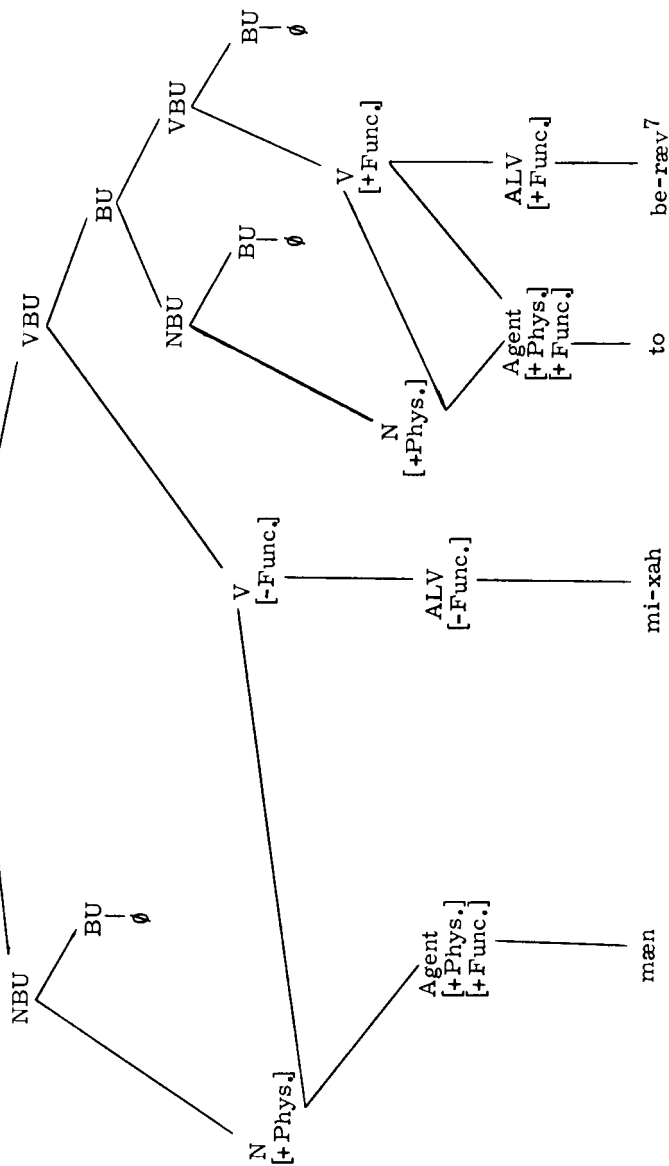

I

In this way the BU of VBU will be responsible for the creation of subordinate clauses without creating demand for extra nodes for embedding.

Similar to the BU expansion of the verb for the derivation of subordinate clauses, the BU of the NBU serves for the derivation of relative clauses. In transformational generative models relative clauses are derived from $N(S')$. In my system they are derived rather similarly. For the difference, however, compare the following derivational 'histories' of Chomsky and myself:

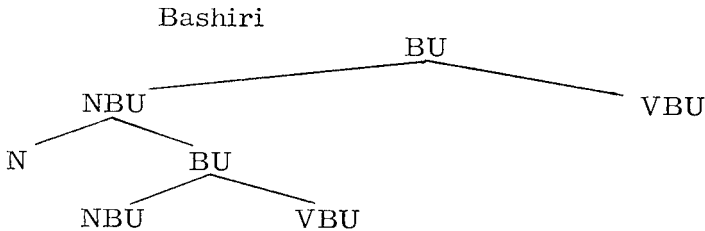
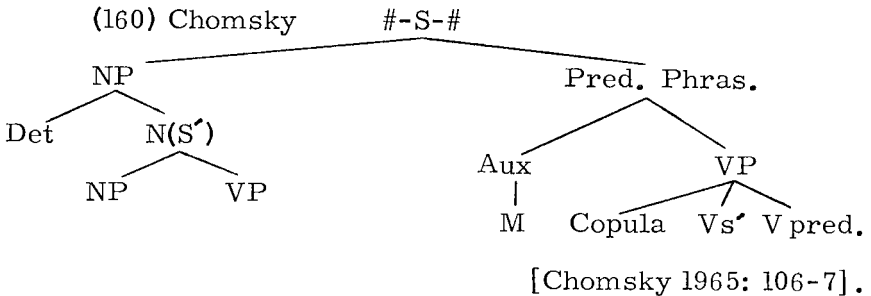

The difference lies in the fact that while Chomsky has to create an NP node as well as an $N(S')$ node for recursive occurrence of clauses, I can introduce both the nominal and verbal clauses as immediate subprojection consequences of my rules.

In terms of rule ordering and rule dependence my system accounts for the recursive nature of language by the second and third rules, while Chomsky accounts for non-deep structure relevant factors like Auxiliaries, modals

and prepositional phrases before his nominal recursive rule:

- (161) (vii) NP \rightarrow (Det) N(S').
 [Chomsky 1965: 107].

The advantage of my derivation of clauses, thus, lies in the fact that it shows that relative clause derivation follows similar processes as completive clause derivation. For further clarification of the procedure for nominal expansion consider the following sentence:

- (162) eskimu-ha ke dær iglu zendegi mi-kon-ænd
 xošhal hæst-ænd.
 Eskimos who live in igloos
 are happy.

The ultimate expansion of the BU component of the nominal primitive NBU gives us:

- (163) eskimu-ha dær iglu zendegi mi-kon-ænd.
 Eskimos live in igloos.

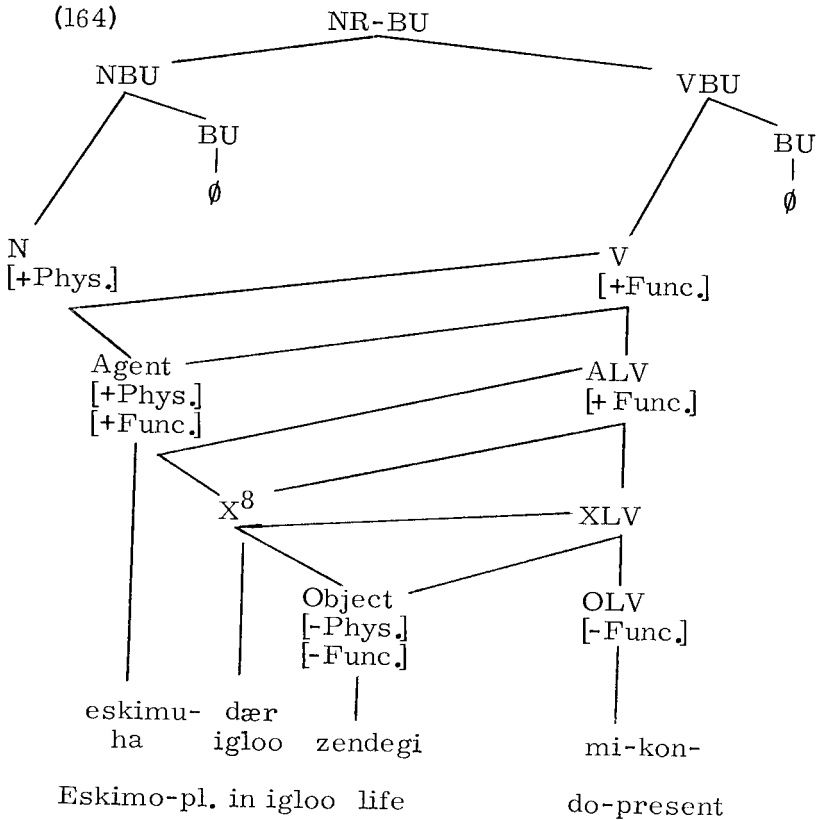

The expansion of the main BU will result in the sentence:

(165) eskimu-ha xošhal hæst-ænd.
Eskimos are happy.

The deep structure representation of this sentence is given below:

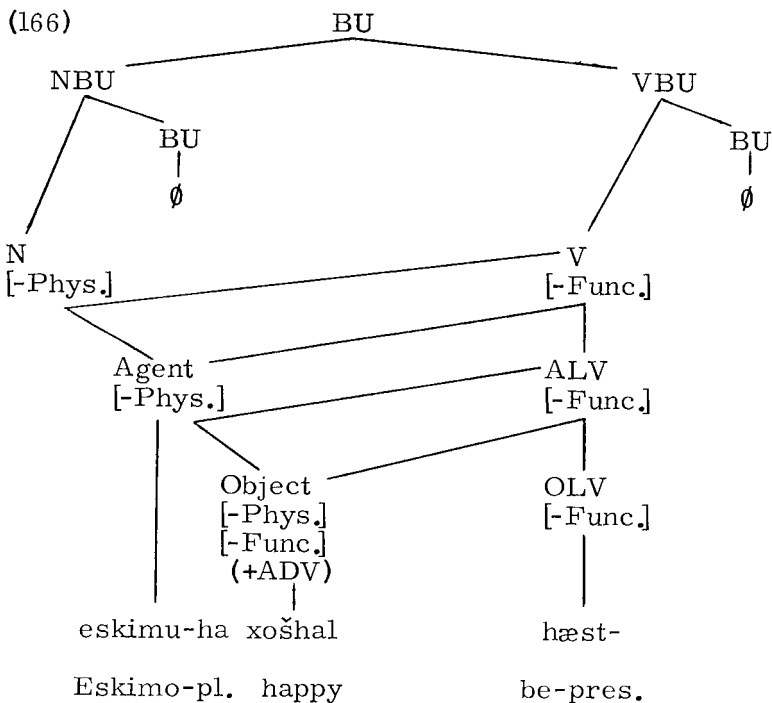

For the generation of :

(167) eskimu-ha ke dær iglu zendegi mi-kon-ænd
xošhal hæst-ænd.

Eskimos who live in igloos are
happy.

the Nonrestrictive clause (NR-BU) is expanded simultaneously with the N of the main clause.⁹ This process is presented on the next page in diagram form:

¹A distinction is made in this framework between the morphological -an-, causative marker, usually referred to as 'Causative' in Persian studies and my deep structure Agent-Source identity relations in which an Agent causes an action to happen.

²Incidentally, it is interesting to observe that textbooks of Persian call sentences of the form:

hušəng-ra did-ænd. They saw Hushang.

a better alternative for translating an English passive.

³The parenthesis indicates that the Agent of the verb is not always realized on the surface.

⁴On diagrams these deep structure processes are marked by double bars (==) instead of the single lines.

⁵For further clarification of the switching of levels compare the following diagrams:

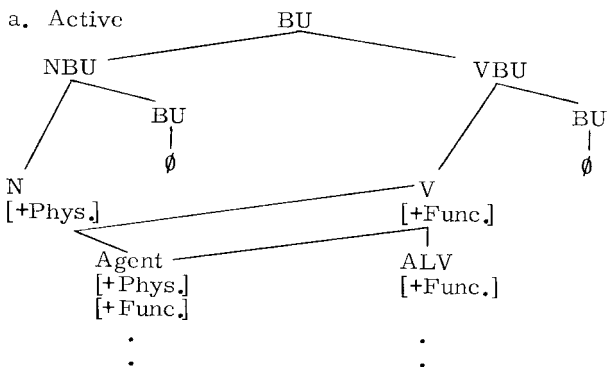

b. Passive

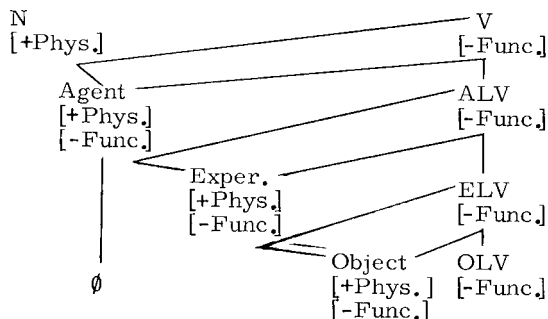

c. Factive

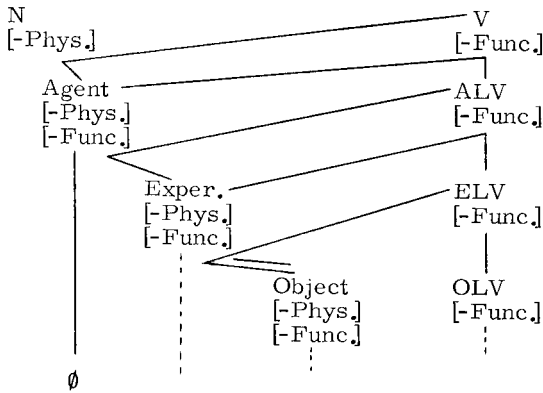

d. Causative: Causative sentences are derived from factive sentences. The Agent is not realized as \emptyset for causative sentences, however.

⁶Note that the deep structure realization of u 'he' is different in a and d from that in c and b.

⁷The deep structure generation of lower level forms like the subjunctive and the plural is omitted from this study.

⁸The Locative and the Temporal are derived through the expansion of the VBU. Since the study of these aspects entails research in specific areas of the syntax of Persian, I have derived the Locative from the nominal. X indicates that the process of derivation is chosen for convenience in presentation.

⁹For distinction between restrictive and non-restrictive clauses see Bach 1968.

Chapter Five

THEORETICAL CONCLUSIONS

5.1 Introduction

The 'history' of the development of modern linguistic theories indicates that most linguists' energies have been exerted on syntactic rather than either morphological or phonological analyses. In fact, both in the United States and in Europe, the focus of recent discussions seems to be heavily set on syntax.

A general overview of the field shows that most of the studies undertaken during the earlier period (1957-1965) of generative syntax were preparatory. They were fundamental, nevertheless, as they aimed at 'higher' and more general levels of analysis searching for an abstract 'universal base' to explicate all linguistic structures. It seems, however, that the sudden rise of generative transformational grammars and their revolutionary changes in linguistic studies reached only a premature culmination in Chomsky's earlier works which soon fell victim to stereotyped 'critical' debate.

The rise of various theorists with insightful notions regarding the structure of English and later application of these insights to languages other than English, only 'enriched' the literature on linguistics. Furthermore, each innovator based his assertions on the findings of his predecessors only to politely 'phase them out' simply by using systematic antithetic approaches. The result is a drastic lack of synthetic studies in a field most in need of synthesis [Cf. Chomsky 1968: 19].

Much of the literature has proved to be useful. Some of it has not. Furthermore, there are areas that linguists like Chomsky tried to close to linguistic research. Only recently, for example, logical and philosophical studies other than mathematical logic, have started to 'creep' back into linguistic analysis. There are, for example, a good number of relevant analytical studies in Arabic and Persian (I know a few like al-Ishārāt wa-al-Tanbīhāt of Ibn Sina) now totally ignored by modern linguistic theorists.

In conclusion, it seems to me that at the outset of his generative venture, Chomsky had two major points in mind. a) He wanted to formalize grammar and claim universality for its rules. b) He wanted to attract linguists' attention to the abstract nature of language and involve them in an abstraction-oriented analysis based on mathematical logic. More attention would have been paid to his assertions if a merger between 'abstract' in the linguistic sense and 'abstract' in the mathematical logical sense had not resulted in a mechanistic type of abstraction, the outcome of which was expectable. Linguistic studies were channelled into the mathematical and away from the linguistic.

In this study I have tried to prove that Chomsky's assertions regarding the existence of an abstract level of syntactic analysis are fully justified. I have also tried to show that Lakoff's assertions, in spite of their truth-functional validity, are justified only for sporadic cases where deep structure regularities achieve only partial surface realization and thus seem irregular. I should admit, however, that I have provided more insights into linguistic structures through the arguments of Lakoff, who, so to speak, fights against the 'current', than through the factual yet unsupported assertions of Chomsky.

5.2 Conclusions

In Chapter One, basically a survey of the literature on syntax and general theoretical approaches to it, I have shown that both pretransformational and posttransformational approaches to Persian have had special merits of their own and have paved the way for higher and more

'mature' approaches. I have also shown that the theory of syntax itself has undergone drastic changes with Western contributions deserving high degrees of credit. However, I have asserted that this degree would still be higher if there was more 'agreement' among Western linguists and if Chomsky's views regarding 'regularity' were honored rather than opposed.

Regarding medieval Iranian logical deduction to achieve linguistic relations I have shown that in spite of lack of formal linguistics, it should be admitted that those studies have captured much of the essence of deep structure relations. They should be formalized if necessary and amended with the achievements of modern linguistic theories; by no means should they be neglected or ignored. Only then the endeavors and achievements of scholars of Classical Greek, e.g. Aristotle, Medieval Islam, e.g. Al-Farabi, Ibn Sina, and Modern Linguists like Chomsky, Lakoff, and Fillmore will unanimously be focused on syntax as a unified, self-sufficient system of high level Abstract versus low level Function relations on the one hand, and atomic relations among specific nominals and verbals at each high or low level specific juncture on the other hand.

Furthermore, in order to give full explanatory power in terms of generation to my statement regarding ontological studies, I have introduced *a multi-valued neutral hierarchy from which the deep structure of all sentences is derived through the application of a neutral inventory of rules coupled later by rule-features using mapping and correlative mapping rules.*

Chapter Two is the most important chapter, because there I have set down my basic assumptions underlying my theory which views syntax as a Unified System. For example, I have asserted that in the same way that syntax is central to grammar, 'to be' (Persian budæn) is central to the study of syntax. Related to this problem I have refuted the traditional definition of the sentence and redefined the sentence in terms of projection, expansion and transformational mapping rules that create it. Thus, *for my framework, the sentence has come to be defined in terms of the constituents that generate it rather than a bound upper limit.*

Furthermore, I have shown that languages seem to have a logically as well as hierarchically ordered deep structure.

I have proved that syntax is a Unified System using hierarchical orderings among its constituents to arrive at Abstract/Abstract-Function/Function realizations of the sentences of the language. For these distinctions there are different feature types each of which is decisive for the generation of a particular sentence at a particular level of derivation. Rule dependency and rule government are shown to function best within multi-functional hierarchies, where each element can be easily traced for either dependency or government to a 'governing' or 'independent' head.

In Chapter Three, I have shown the relevancy of the type of abstract framework outlined in Chapter Two to the study of Persian structures. To show this I have given various types of sentences and assigned deep structure realizations to them.

Each sentence, according to my framework, falls within one of the Subsystems of the Hypersystem. *However, I have shown the possibility of postulating an Inchoative 'be' matrix through which verbs like 'become' and 'do' can be regularly derived as an automatic consequence of transformations across the levels of the Hypersystem.*

Furthermore, I have shown that unidirectional verbs like didæn 'to see' and danestæn 'to know' are regular verbs on the level of Abstraction/Function. Namely, while the Agent of these verbs is functional and concrete, their Experiencer is nonfunctional.

In order to show the generative power of the framework I have chosen the discussion of the 'passive' in relation to the 'causative', the 'factive' and the 'active' sentences. I have shown that within the budæn or Summary Matrix, there are possibilities for certain transformations from one sentence type to the other. Thus, I have shown that Causative is an automatic consequence of subject raising and function identity in the Abstract Subsystem, while passive is the automatic consequence of Experiencer-Object identity on the 'Mixed' level of the Hypersystem.

The recursive nature of language drew attention even at

the outset of generative transformational grammars. Chomsky, for example, first assigned an expandable symbol Z to express this notion and later changed this symbol for embedding subordinate sentences in matrix sentences. The mechanism, nevertheless, remained about the same. *I have defined main and subordinate clauses in terms of projection and subprojection rules. Furthermore, I have devised a system in which subordination becomes an automatic consequence of nominal and verbal expansion.* The interrelation of the subprojections of NBU and VBU and necessity for setting up mechanisms like global constraints will have to be explored later [cf. Lakoff 1970a].

Appendix A

VERB COMPOUNDING

A.1 Introduction

One of the noteworthy problems of Persian syntax for which current linguistic theories have not offered an adequate solution is the problem of verb classification and, related to it, compounding of verbs. Generally, verb classification, is viewed as one of the most researched aspects of the linguistic act and, consequently, the literature on it has direct theoretical support. Conversely, verb compounding for Persian is viewed merely as a language specific (hence Persian verb compounding) phenomenon, which view is not acceptable and is in fact misleading. English and German both make free use of the mechanism that is usually interpreted for certain superficial structures as compounding.

The term 'compounding of verbs' is usually explained as the 'fusion' of a meaning-bearing nominal with a required syntactic 'dummy' verb for surfacing [Cf. Stilo 1971: 52]. Although on the surface all affixes are attached to the dummy verb, the N/V combination acts as a so-called semantic unit. Verbs like kærdæn 'to do', xordæn 'to eat', ræftæn 'to go' are usually assigned a double function. They are regarded as both regular verbs acting as main verbs, and as dummy verbs creating compounds.

(Before proceeding with the discussion of the treatment of the compounds I should add that 'compounding', or the mechanism that can fully justify processes regarded as 'compounding' in my system, has deep as well as surface structure

justifications. My system, however, has not developed the detailed derivation of any one aspect of the grammar outlined above. My concentration in general deep structure analysis, therefore, still leaves ample opportunities for further research.)

A.2 Approaches to Compounding in Persian

A.2.1 The Structuralist Approach

The apparent reason for setting up the whole concept of verb compounding in Persian is due to the surfacing of certain deep structure relations in the form of observable N/V proximities at certain syntactic junctures. Within a uni-level analysis the apparent semantic fusion of the two elements, namely the nominal and the verbal at different N/V junctures and the semantic control of these structures, (usually represented as a whole unit distinct in meaning from the semantic value of the sum of their parts), could not be interpreted in any other way.

In fact, compounding was inherited by the pretransformationalists who devised the criteria for distinction between preverbs and compound verb constructions.

Three features were closely associated with preverbs: a) preverbs could not take the postposition -ra (in case of transitive verbs), b) the use of preverbs was limited to certain verbs, and c) the number of the elements that could occur between a preverb and its verb was limited to suffix pronouns. For instance, it was claimed that [Jazayery and Paper 1961: 200-1]:

(1) tæškil-æš dad.

He established it.

is the farthest surface expansion possible for the compound verb tæškil dadæn 'to establish'.

The claim would hold good if it were not for the fact that sentences like :

(2) tæškil-æš-ra dad-æm.

I established (did establish) it.

3. hušang xub piš-miravad.

'Hushang progresses well.'

These sentences have the following approximate (his wording) deep structures. Irrelevant details are omitted:

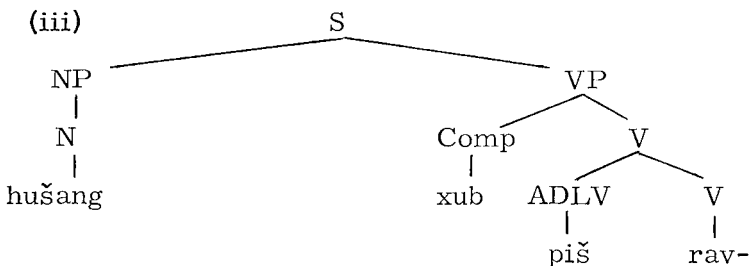
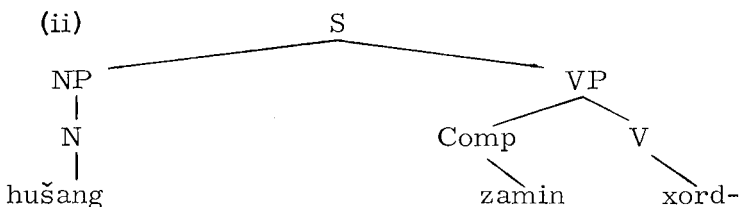
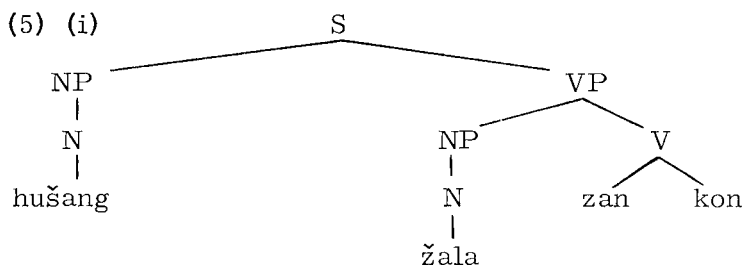

Although Moynes's presentation seems drastically different from the solution presented by the structuralists, one can argue that, basically, he makes the type of deep structure distinctions that the structuralists had already made on the surface. Thus, he 'creates' a deep structure which is hardly different from a 'surface-deep' node cor-

Unified System. However, I have proved that syntax is a Unified System. On that token *I assert that the process so far referred to as compounding has nothing to do with any particular union of a nominal and a dummy verb.*

The process, if analyzed correctly, a) proves to be more complicated than has been deemed so far and b) is related to the interpretation of certain deep structure realizations of superficial Univocals in terms of the Subsystems of the Hypersystem and the levels of the Subsystem involved.

Stilo, for example, asserts that in the deep structure of Vafsi¹ there is no distinction between the verbs 'to see' and 'to look at' [Stilo 1971: 53]. For examples he gives the sentences which are reproduced below in (7):

- (7) a. az ketaab at-vin-om I see (a book) books.
 b. az ketaab navaa at-kar-om I am looking at the book.
 [his transcription and my translation].

Below I will reproduce the deep structure of these two sentences as given by Stilo on page 53 of his dissertation. (7-b), by the way, has an instance of a compound verb:

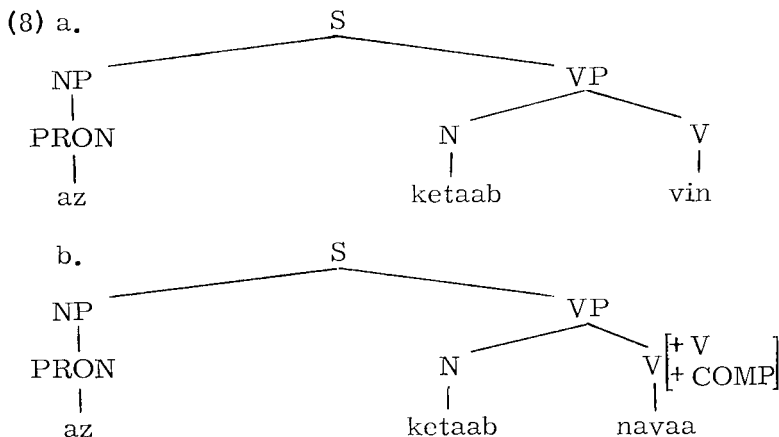

can pattern with nonfunctional nouns and be interpreted as a nonfunctional (or 'dummy' in current literature), verb patterning with the nonfunctional verbs šodæn, didæn and zædæn, in its nonfunctional form (e.g. seda zædæn 'to call a person'), etc.³ Below is a chart showing the deep structure relation of didæn and negah kærðæn to the nominals involved.

Figure A-1
Compounds Analyzed in Terms of Levels and Relations

Func. Level	A	O	V	
M	U [+Phys.] [+Func.]	<u>sædæme</u> [-Phys.] [-Func.]	<u>did</u> [-Func.]	He was hurt
M	U [+Phys.] [+Func.]	<u>zæn</u> [-Phys.] [-Func.]	<u>kærð</u> [-Func.]	He got married.
		<u>negah</u> [-Phys.] [-Func.]		He looked (at something).
F	U [+Phys.] [+Func.]	<u>zæn</u> [+Phys.] [+Func.]	<u>kærð</u> [+Func.]	He made a woman.

The analysis presented above shows that didæn and kærðæn pattern alike *only on the Object level* which have nominals with [-Phys.] feature specification. Otherwise kærðæn will be totally functional.

Stilo's observation regarding the postulation of the same deep structure would make sense only if didæn, a regular verb of the 'mixed' level, could always pattern exclusively

with the kærdæn of that same 'mixed' level. However, it is obvious from the analysis presented above that in the deep structure these two verbs are drastically different. Consequently, the proximities that they create in the deep structure turn out to be different.

For support of the argument against Stilo's common deep structure for didæn and negah kærdæn consider the following sentence:

hamey-e parce-ha-ra negah kærd-æm væli
hicyek-ra dust næ-dašt-æm.

I examined all the different
types of material but didn't
like any one of them.

In which case to examine something is different from to look at it, in that 'examine' takes a Physical-Functional Object (using fingers, for example) and a Functional verb. In that instance, negah is [+Phys.],
[+Func.]

I would like, however, to postpone my final judgement regarding the treatment of compound verbs according to this framework until later when more lower level details for supporting my arguments are worked out.

¹Vafsi-Tati as an Iranian dialect is related to the Iranian dialect usually referred to as modern standard Persian.

²Fillmore distinguishes these two verbs by presenting the following case frames for them:

see (+[— O + D])
look (+[— O + A]) [Fillmore 1968:31].

Dowty also, on independent grounds distinguishes these two verbs [Dowty 1971: 26].

³A similar, although less general observation is contributed by Paper in his review of Lazard. Regarding kærdæn 'to do' he says:

However, let us consider that kardán is a verb that means not only 'to do, make', but also is a widely used 'empty' verb that patterns like the more readily translatable âmadán 'to come', zadán 'to strike,' but fulfills the general function of verb-filler in periphrastic verb compounds; then âftâb mikonad may be taken to be a subject + verb sentence [Paper 1959: 37].

Appendix B

TERMINOLOGY

Abstract: Abstract as opposed to concrete is the characteristic of the level on which only nonfunctional hierarchies can produce sentences. It creates a medium susceptible to Animation.

Abstract-Function Subsystem (A-FS): If the Projection and Expansion rules result in either N_[-Phys.], V_[+Func.] or

N_[+Phys.], V_[-Func.] the hierarchy of Transformational

Mapping and Correlative Mapping rules will constitute a 'mixed realization' of the N and V involved. The direction towards Abstraction or Functionality for the sentence depends on the features involved and the Slot at which the change from one feature to the other occurs.

Abstractization: Abstractization, as opposed to Concretization, is the process through which an originally functional slot (except Agent) is shifted to a higher level: from Function to Abstraction. It loses its functional power but is still susceptible to animateness rather than animation. For further illustration compare the following sentences:

- | | |
|-----------------|---------|
| a. mæn hæst-æm. | I am. |
| b. mæn ræft-æm. | I went. |

Nonfunctional elements have typically imposed features as opposed to inherent features.

Abstract Realization: A linguistic entity is abstractly real-

ized if it is defined in terms of Verbs that have [-Function] and Nouns that have [-Physical] feature values.

Abstract Subsystem (AS): If the Projection and Expansion rules result in N and V the hierarchy of [-Phys.] [-Func.]

Transformational Mapping and Correlative Mapping rules will constitute an abstract realization of the [N] and [V] involved and the entire derivation will be the highest of the mutually exclusive Subsystems of the Hypersystem. Verbs that are related to this Subsystem are mostly transformed forms of the underlying matrix budæn. At this level and through Agent creation the causative sentences of the language are derived. Thus sentences like:

jængæl kudæk-ra tærsand.
The forest frightened the child.

will be derived from the underlying:

jængæl ba'es-e tærs-c kudæk æst.
The forest is the cause of the
child's fright.

Agent: For Agent see page 48 above.

Ambiguity: For Ambiguity see Univocals below.

Anaphoric: Any type of information which is mapped into the BU component of a Nominal or Verbal from the indices in the Universe of Discourse.

Animate: Animate is an automatic semantic feature that distinguishes the hierarchy of Functions within the Hypersystem. It is for lower level subcategories (cf. Rule Features below). The Agent and Experiencer are typically animate on the level of Functions while the Path and the Object are not. Furthermore, in the lexicon it will automatically distinguish the lexical features of the lexemes to be mapped into the Agent and the Experiencer from the ones to be mapped into the Path and the Object.

Animateness: Animateness as opposed to animation is attributed only to the Functions and not to Abstractions.

All slots which have the rule feature specifications, [+Phys.] for nouns and [+Func.] for verbs, will automatically have the feature [+AN] entered in their lexical specification.

Animation: 'Animation', as opposed to animateness, is devised in this framework to distinguish the abstract nature of 'existence' from its functional character. Thus, each function F can be realized (in concreto) for all persons except for the third which being neutral can be realized as animated, i. e. only in abstracto. Sentences of the type:

jængæl kudæk-ra tærsand.

The forest frightened the child.

have animated, 'created' Agents. All slots which have the rule-feature specification [-Phys.] for nouns and [-Func.] for verbs will automatically have the feature [+ANIM] entered in their lexical specification.

Causative: The term causative of this framework is different from the causative used by traditional linguists (namely the morphological surface marker -an- marking certain verbs as causative). For this framework causative is a deep structure mechanism describing action in terms of Agent-Source causation.

Centrality of budæn: This framework assumes that syntax is central to the study of grammar and that budæn, the realization of 'existence', manifested as a transitional stage from the real world to the linguistic media is central to any mechanism involved in the explication of linguistic structures. Using budæn as an Inchoative base for transformations, it also claims that language uses a series of systematic 'emanation' acts transforming the Abstract into the Functional and the concrete. (See also Inchoative Base below.)

Commitativity: Commitativity is the simultaneous occurrence of two or more events or togetherness of two or more persons and/or things in a way that they do not exert any affectum-effectum relation on each other. For instance:

- a. bad ba baran xane-ra xærab kærdænd.
Wind and rain ruined the house.
- b. hušæng ba æli ræft.
Hushang went with Ali.

are examples of commitativity. Note that commitativity is not always marked by ba 'with' on the surface.

Conceptualized Primitive: The linguistic primitives after the expansion rules are applied.

Concrete: Concrete as opposed to Abstract is the characteristic of the level in which only functional hierarchies can produce sentences. It creates a medium most susceptible to animateness and concreteness (in concreto).

Concreteness: Concreteness as opposed to Abstraction is the tangible medium with which the hierarchy of functions deals.

Derivation: Consecutive application of grammatical rules to a postulated deep structure in order to convert it to its surface structure realization.

Diagram: The relations that hold among the various elements of each sentence are diagrammed in terms of projection, expansion and Transformational Mapping and Correlative Mapping rules that partake in the creation of that particular sentence. The diagrams are designed for this framework and are viewed as logical as well as linguistic relationship indicators.

Existence: Existence is a matrix type network of 'relations' temporal/spatial as well as nominal/verbal, expressed in terms of deep structure propositions. Most of these deep structure 'relations' have so far been attributed to surface prepositions, traditional cases and recently actor-action relations.

Existent Composition: The term Existent Composition is introduced to replace the traditional Phrase Structure (PS) rules. The reason for the change of terminology lies in the fact that the Phrase Structure rules were not basically transformational rules and their internal structures did not have the hierarchical mechanism that Existent Compositions have for logical deductions.

Expansion: After the projection mechanism has established the 'linguistic picture' of the real world, namely conceptualized primitives (NBU, VBU) either one of the conceptualized primitives can be expanded. In this way each component can independently be modified as the derivation of sentences progresses.

Factive Sentences: Factive sentences are those sentences which are derived on the Abstract level of the Hypersystem. The sentences are characteristically Agentless. Factive sentences serve as the base for causative sentences which are derived from the factive sentences by a process called Agent creation.

Feature Specification System (FSS): The FSS is an inventory of Mapping and Correlative Mapping rules identifying the relationship that holds between the Neutral System and the Subsystems of the Hypersystem. The features widely used in this study are [+Physical] and [+Function]. These inherent features which always appear on V/N nodes, however, differ from but do not preempt the use of lexical features of the type [[+Human]], [[+Count]], etc.

Function: Function, as opposed to abstraction--a dichotomy I use advisedly--is the logical sum of the linguistic primitives N and V if they have the rule-features [+Physical] and [+Function] respectively. Functions are created by mapping rules stemming from the higher medium (functionality) of (V) and affecting the lower medium (physicality) of (N). Unless coupled with correlative rules, the potential functions will not become functional. At the level of functions, original primitives become susceptible to concretization, animateness, realization and eventually surface after passing through the lexicon.

Functionality: Functionality as opposed to Physicality is the characteristic of the medium in which only verbs can originate. All nominal and verbal function orientation stems from this medium.

Function Subsystem (FS): If the Projection and Expansion rules result in N and V the hierarchy of
 [+Phys.] [+Func.]
 Transformational Mapping and Correlative Mapping

rules will constitute a functional realization of the N and V involved and the entire derivation will be within the domain of active verbs (see Active verbs above).

Hierarchy: In the Unified System there are six types of hierarchies to be distinguished:

1. The Unified Hierarchy has three members. These members are cited below:
 - a. budæn
 - b. Neutral Hierarchy
 - c. The Hypersystem
2. The Neutral Hierarchy is the hierarchy in which the accumulation of Neutral Slots results in the realization of the following potential Neutral Slots. These Slots and the strings following them do not have surface realization:
 1. Neutral Agent
 2. Neutral Source
 3. Neutral Path
 4. Neutral Experiencer
 5. Neutral Goal
 6. Neutral Object
3. Hypersystem is the hierarchy which is created by the identification of rule-features with the rules of the NS. The Hypersystem has three Subsystems. The type of FSS rules involved in the derivation identifies the levels of the hierarchy. The members of the Hierarchy, according to priority, are:
 1. The Abstract Subsystem
 2. The Mixed Subsystem
 3. The Function Subsystem
4. The Abstract Hierarchy is modelled on the Neutral Hierarchy with the same type of structuring. The distinction between the two lies in the fact that the Abstract Hierarchy has negative specification rule features.
5. The Mixed Hierarchy is also modelled on the Neutral Hierarchy with the same type of internal structuring. The distinction between the two lies in the fact that the Mixed Hierarchy can select both positive and neg-

ative features.

6. The Function Hierarchy is the last hierarchy modeled on the Neutral Hierarchy. It has the same type of internal structuring. The distinguishing factor for the two is the positive features that are associated with the Function Hierarchy.

Within the Neutral, Abstract, Mixed, and the Function Hierarchies the following subgroupings are possible. My example below shows only the subgrouping of the Neutral Hierarchy:

- group a: Neutral Agent
 - Neutral Source
 - Neutral Path
- group b: Neutral Experiencer
 - Neutral Goal
 - Neutral Object

Hypersystem: Hypersystem is a fictitious 'cover term' which distinguishes the complex of three Subsystems drawn from the Neutral System, and the Neutral System itself. The arrangement of the Subsystems within the Hypersystem is done through the FSS. Within the Hypersystem there are three distinct hierarchies: the hierarchy of Functions, the hierarchy of Abstractions, and a 'mixed' hierarchy namely the hierarchy of Abstraction-Function.

Inchoative Base: The Inchoative Base is the base from which, through the application of transformational rules, different sentences belonging to different subsystems of the Hypersystem are derived. The procedure indicates that between slots, relations are constant, while the slots themselves act as variables. It is this type of modification of the base that creates the different sentences of the language at different levels of the Hypersystem. This framework asserts that sentences with budæn are 'primitive' Inchoative sentences.

Inherent Feature: The term inherent feature is used in contradistinction to lexical features. Inherent features are those semantic features which constitute syntactic relations among linguistic forms, and which appear on syntactic nodes (see Lexical Component below).

Instrumentality: The use of a means by an Actor in order to change the state of events in a static Actor-Action-Experiencer relationship, e.g. in:

Actor means Exper. Action
 hušəng ba qollab mahi gereft.

Hushang caught a fish using a hook.

It should be remembered, however, that Instrumentality is a matter of Universe of Discourse projection across sentences, thus:

hušəng mahi gereft.

Hushang caught a fish.

qollab mahi gereft.

The hook caught a fish.

Neither hušəng nor qollab 'hook' could have caught a fish alone. In this sense Instrumentality is a form of com-mitativity.

Internal Structuring: The term Internal Structuring refers to the order and number of the Transformational Mapping and Correlative Mapping rules that take part in the creation of a simple sentence.

Levels: Levels, within each of the hierarchies described (see Hierarchy), are created by the application of the Transformational Mapping rules and their Correlatives. If there are levels that are skipped due to certain special requirements, this requirement becomes a point of distinction for the verb and realizations that skip that level are classified accordingly.

Lexical Component: The Lexical Component or the Lexicon is an inventory of lexical feature complexes which specify the output of syntactic relations achieved through rule-features and the NS. This is done through the lexical feature complexes identified by [[]]. [See also Langendoen 1969: 152].

Linguistic Primitive: Before linguistic concepts (verb, noun) are realized in the deep structure, they are shapeless yet potential units each having its own 'essence'. Verb-ality and nominal qualities are much later qualifications of these two 'essences'.

Multifunctionality: A totally new concept claiming that a-side from Abstraction, Function and Abstract-Function

distinctions all verbs bear basically the same type of hierarchically ordered relations to the realization of the Nominals. Each verb is assumed to have distinct deep structure realizations, for example, ALV, SLV, PLV, etc. These realizations usually surface univocally (see Univocal below).

Neutral Nature: In the deep structure the linguistic phenomenon uses a series of Neutral rules and rule features, untranslatable into any type of immediate surface structure. Thus I claim that the linguistic act has a natural yet neutral nature, definable in linguistic terms through language universal rules. Language specificity, however, is a special case of language universality in which the FSS is further modified by mechanisms that distinguish specific languages.

Neutral Slot: Neutral Slots are the result of the projection and expansion of the linguistic primitives V and N. Their mapping and correlation creates a series of hierarchically ordered sets, receptive to feature specification by the FSS.

Neutral System (NS): The NS is the unmarked system on which all the subsystems of the Unified System draw. The output of the NS is an unmarked, undefined sum of accumulated neutral potential slots to be specified by the Feature Specification System. Without the help of the FSS the string that originates from the NS has no possible surface realization.

Noun: Noun is defined as the result of the gradual 'affectation' of action on function, in such a way that at each point in the process the type of 'affectation' can be distinguished.

Path: See page 51 above.

Physical Realization: A linguistic relation is physically realized if it is defined in terms of verbs that have the inherent feature [+Function] and nouns that have the inherent feature value [+Physical].

Potential Concept: The term potential concept signifies that at a certain stage in the derivation of a function or combination of functions (a sentence), all requirements for the generation are accomplished except the mapping

and correlative mapping which result in particular function or sentence at a particular level.

Projection: Projection for this framework is a mechanism that stimulates the potential qualities of the primitive essences and shapes them according to its own 'picture' [Wittgenstein 1922: 39-47] of the real world.

Quiddity: A 'quiddity' in the mental mode of 'existence' furnishes the basis for concept formation. Without this basis all concept forming process is doomed to failure [Izutsu 1969: 7].

Real World: Real World is the world of concrete objects as they are touched and handled by human perception. It is, in Wittgenstein's words: 'the totality of existent atomic facts' [Wittgenstein 1922: 37].

Rule Dependency: The rules of this grammar are applicable only in a hierarchical order. This grammar specifies that earlier rules (the V of earlier rules) govern possible structural changes with the result that the last rule has the accumulated information of all previous rules. Thus each lower rule is dependent on a higher rule for information while each higher rule is dependent on the lower rule for completion of the information.

Rule Features: Same as Inherent Features above.

Rule Government: The Transformational Mapping and Correlative Mapping rules of this framework all stem from the V linguistic primitive. V becomes the most dominant and thus, the governing element of any given sentence. This assumption is strengthened by the fact that only the Verb in each derivation accounts for the type and number of Nominals involved in each derivation.

Sentence: In general any string that is the outcome of the mapping procedures outlined above is a sentence or existent (BU) of Persian. It can be on the ALS level like ræft-æm 'I went' or on the ELS like mæn hæsæn-ra did-æm 'I saw Hassan'.

Source: See page 50 above.

Sub-BU and Recursiveness: Each conceptualized linguistic primitive (VBU, NBU), has as an inherent part of it a subcomponent BU. This BU component can be expanded as extension of the Nominal or Verbal, as the case

may be, to produce clauses that directly modify either of the V or N under consideration.

Subprojection: See Sub-BU above.

Subsystem (S): Subsystems are the constituent parts of the Hypersystem. They are the results of the application of the Feature Specification System to the Neutral System. The three Subsystems are: the Function Subsystem, the Abstract Subsystem, and the Abstract-Function Subsystem. The internal structuring of the Subsystems is similar to the internal structuring of the Neutral System.

Syntax: Syntax is a unified system of interrelationships of the real world and the linguistic media through a projectory mechanism that uses logic-oriented linguistic rules. The rules of syntax are transformational rules and relate atomic Nominals and Verbals in an affectum-effectum way.

System: The word system is used here in a relative way. It can apply to a hierarchy of rules that result in a particular sentence, namely the 'coupling' of the Neutral System and one of the Subsystems, or it can refer to the complex of budæn, the Neutral System and the Hypersystem namely the Unified System. In both cases it indicates the relationship that holds among the constituent parts in order to be realized as a unified whole.

Transformational Mapping and Correlative Mapping: I have introduced three types of rules involved in the Existence (BU) Composition presented for this framework: Projection Rules, Expansion Rules, and Mapping Rules. Mapping rules are further divided into Mapping and Correlative rules.

Within each sentence there is only one main Projection Rule and as many Subprojection Rules as needed. The Projection Rule, which involves 'existence' and the two linguistic primitives (V and N), acts within a highly abstract sphere and causes the linguistic primitives to be conceptualized.

The Expansion Rules, contrary to the Projection rules 'extract' the abstract existence out of individual concept-

ualized primitives and make them receptive to Animation, Concretization (in the abstract sense), and Realization. This procedure, when coupled with Subprojection Rules, can reflect relativity in the context of N and adverbiality in the context of the concepts Time and Place.

Subprojection Rules act exactly like the main projection rule, only at lower levels. The subprojection rules can expand and create nominal and adverbial clauses.

Mapping rules, which create Neutral, Abstract and Functional slots, work on the result of the expansion rules, and create logical sums of the linguistic primitives they map into each other. Thus, the logical sum of a predicate (V) and a nominal (N) will result in a slot, which is the logical sum of V and N. In the case of Functions, for example, the logical sum explained above can be formalized as follows:

$$(MR): V \cup N \longrightarrow F(VN)$$

This is read as the logical sum of V and N is the function of their combination. The procedure is reversible; a Correlative Mapping procedure is introduced. It is assumed that the logical sum mapped into the abstract primitive should be able to specify the type and eventually the level of functionality. Thus:

$$F(VN) \cap V \longrightarrow F(NV)L$$

To give a linguistic context, I assume that if the mapping of V onto N results in the function Agent, the correlative mapping of Agent onto the V should be able to specify the level of functionality of V in relation to the Agent Function.

Undefined String: The output of the Neutral System is an undefined, nevertheless potential string indicating potential information regarding the number and types of Mapping and Correlative Mapping rules involved in the

derivation of each sentence before the sentence is defined by FSS and categorized in the Hypersystem Hierarchy.

Unified System (US): The syntax of language is presented as a unified system in which a Neutral System serves as the unmarked base and from which the different subsystems draw their inventory of sentences by the help of Feature Specification System. The unifying factor within the Unified System of Persian syntax is assumed by this framework to be budān 'to be'.

Universe of Discourse: Whenever I refer to the UD, I am referring to a network of BUs, parts of which complex are or can be either implicitly or explicitly (anaphorically) reflected in the Sub-BUs of each individual BU under discussion. The UD handles the 'restrictive/nonrestrictive', 'points of reference' and ellipsis, as well as information on possibility, necessity, obligation, etc.

Univocal: The surface realization of all the different realizations of a Nominal or a Verbal (in the deep structure) can be represented by the same 'form'. This 'form' which has the same phonological realization for different syntactic relations is called, by this framework, Univocal.

Unrealized Concept: When the application of the mapping rules is accomplished they will result in a Neutral String derived at a certain level of derivation. In order for this unrealized concept of the sentence to be realized and surface as a linguistic phenomenon it has to pass a) through the FSS, b) the lexicon which immediately follows the transformational mapping rules and c) through the phonological component which transforms the lexical elements supplied for the sentence into acceptable surface realizations. The unrealized concept of the sentence is usually referred to, in this framework, as the Level Sentence where it can refer to one of the levels in the subsystems of the Hypersystem.

Verb: Verb is defined as the result of the gradual 'effect' of Agent, etc. on action in such a way that at each point in the process the degree of the 'effect' can be measured.

Verb Level: The governing element of the sentence, according to this analysis, is the Verb. The level of Abstrac-

tion or Functionality of the verb is decided by the FSS rules. The levels at which the verb is related to the set of Nominal realizations (Agent, Source, Path, etc.) is decided by the type and number of Mapping and Correlative Mapping rules involved.

REFERENCES

- Ackrill, J. L. 1963. Aristotle's categories and de Interpretatione. Oxford at the Clarendon Press.
- Avicenna, 1019. resale-i dær mænteg 'A Treatise in logic' in Muhammad Mo'in, 1952. daneš name-e 'ala'i 'The 'Ala'i Encyclopædia', University of Tehran Press.
- Bach, Emmon. 1964. An introduction to transformational grammars. New York: Holt, Rinehart and Winston.
- _____. 1968. "Nouns and noun phrases." Universals in linguistic theory. Ed. by Emmon Bach and Robert T. Harms. New York: Holt, Rinehart and Winston, pp. 90-122.
- Bashiri, Iraj. 1972a. 'To Be' as the origin of syntax. Unpublished doctoral dissertation, University of Michigan, Ann Arbor.
- _____. 1972b. Persian for beginners. Middle Eastern Languages and Linguistics #1, Bibliotheca Islamica. Minneapolis, Minn.
- Batani, Muhammad R. 1968. towsif-e saxteman-e dæsturi-e zæban-e farsi bær bonyad-e yek næzæriye-e 'omumi-e zæban. Unpublished doctoral dissertation, University of Tehran.
- _____. 1969. "nesbiyæt dær zæban." Revue de Faculté des Lettres et des Sciences Humaines. Vol. 17. No. 72. pp. 125-142. Tehran.
- Baumann, Hans-Heinrich. 1971. Die generative Grammatik und Wilhelm Humboldt. Poetica 4, Heft one.
- Becker, Alton. 1967. A generative description of the subject tag-meme. Unpublished doctoral dissertation, University of Michigan, Ann Arbor.
- Bleek, A.H. 1857. A concise grammar of the Persian language. London.
- Cannon, Gerald H. Jr. 1952. Sir William Jones Orientalist. University of Hawaii Press, Honolulu.
- Chafe, Wallace L. 1970. "A semantically based sketch of Onondaga." International journal of American linguistics. Vol. 36, No. 2.
- Chomsky, Noam. 1957. Syntactic structures. The Hague.
- _____. 1965. Aspects of the theory of syntax. Cambridge, Mass.: M.I.T. Press.

- Chomsky, Noam. 1968. *Language and mind*. M.I.T. Harcourt, Brace and World.
- Crystal, David. 1971. *Linguistics*. Hazell, Watson and Viney United Kingdom.
- Dowty, David R. 1971. *Some aspects of a theory of aspect (preliminary version)*. University of Texas.
- DeMauro, Tullio. 1967. *Ludwig Wittgenstein: His place in the development of semantics*. Foundations of language supplementary series. Vol. 3. Dordrecht, Holland.
- Fillmore, Charles J. 1968. "The case for case." *Universals in linguistic theory*. Ed. by Emmon Bach and Robert Harms. pp. 1-88. New York: Holt, Rinehart and Winston.
- _____. 1968a. *Lexical entries for verbs*. [mimeographed].
- _____. 1970. "Subjects, speakers and roles." *Working papers in linguistics* 4. Columbus, Ohio: The Ohio State University computer and information center.
- _____. 1971. "Some problems for case grammar." *Working papers in linguistics* 10. pp. 245-64. The Ohio State University, Columbus, Ohio.
- Gladwin, Francis. 1801. *The Persian moonshee*. Calcutta.
- Gruber, Jeffrey. 1965. *Studies in lexical relations*. Unpublished doctoral dissertation, Cambridge, M. I. T.
- Hall, Barbara. 1965. *Subject and object in English*. Unpublished doctoral dissertation, Cambridge, M.I.T.
- Halliday, M. A. K. 1967. "Notes on transitivity and theme in English." *Journal of linguistics*, III. pp. 37-81.
- Humbolt, W. von. 1876. *Über die Verschiedenheit des menschlichen Sprachbaues*. Berlin. S. Salvary and Company.
- Izutsu, Toshihiko. 1969. "The fundamental structure of Sabzawari's metaphysics." *The wisdom of Persia*. Vol. 1, Tehran. Offset Press.
- Jacobs, Roderick A. and Peter S. Rosenbaum. 1968. *English transformational grammar*. Blaisdell Publishing Company. Waltham, Mass.
- Jazayeri, M. A. and Herbert H. Paper. 1961. *A reference grammar of modern Persian*. U. of Michigan [Unpublished].
- Jespersen, Otto. 1965. *The philosophy of grammar*. W.W. Norton and Company. New York.
- Jones, Sir William. 1771. "A grammar of the Persian language." *English linguistics 1500-1800*. No. 139. The Scholar Press Limited, Menston, England. 1969.
- Kasravi, S. Ahmad. 1955. *zəban-e farsī vā rah-e rāsa vā tāvāna gərdānīdān-e ān*. Tehran, Sharq Press.
- Katz, Jerrold J. and Jerry A. Fodor. 1964. "The structure of a semantic theory." *The structure of language: readings in the philosophy of language*. Prentice-Hall, Inc. Englewood Cliffs, New Jersey.
- Khanlari, Parviz N. 1970. "fe'lha-e nagozær" *Soxan*. Vol. 20,

- No. 1. pp. 10-17. Tehran.
- Khoromof, A. 1970. "dær bare-e ævælin ketab-e særf væ næhv-e zæban-e farsi dær orupa." *Soxan*. Vol. 20, No. 1. pp. 85-86.
- Khunsari, Muhammad. 1959. gævanin-e mænteq-e suri. Tehran University Press.
- Lakoff, George. 1970. *Irregularity in syntax*. New York: Holt, Rinehart and Winston.
- _____. 1970a. *Global rules or the inherent limitations of transformational grammars*. University of Michigan. Version of January, 1970.
- Lambert, Dorothy M. 1969. *The semantic syntax of metaphor: a case grammar analysis*. Unpublished doctoral dissertation. The University of Michigan, Ann Arbor.
- Lambton, Ann K. 1957. *Persian grammar*. Cambridge, England: University Press.
- Langendoen, D. Terence. 1969. *The study of syntax*. New York: Holt, Rinehart and Winston.
- _____. 1970. *Essentials of English grammar*. New York: Holt, Rinehart and Winston.
- Lazard, Gilbert. 1957. *Grammaire du Persan contemporain*. Paris. C. Klincksieck.
- _____. 1970. "Persian and Tajik," *Current trends in linguistics*, Ed. Thomas A. Sebeok. Vol. 6, pp. 64-96. Mouton: The Hague.
- Lee, Gregory. 1971. "Subjects and agents: II." *Working papers in linguistics*, No. 7. Computer and information science research center. The Ohio State University, Columbus, Ohio.
- Lentz, Wolfgang. 1958. "Das Neupersische." *Handbuch der Orientalistik*. Hsg. v. Bertold Spuler. Abt. 1. Bd. 4 Abschn. 1. Leiden and Koln.
- Li, Ying-che. 1972. "Sentences with be, exist and have in Chinese." *Language*, Vol. 48, No. 3. pp. 573-584.
- Lyons, John. 1966. "Towards a 'notional' theory of the 'parts of speech'," *Journal of linguistics*, II, pp. 209-36.
- McCawley, James. 1968. "The role of semantics in a grammar." *Universals in linguistic theory*. Ed. by Emmon Bach and Robert T. Harms. pp. 124-169. New York: Holt, Rinehart and Winston.
- McCoy, Ana Maria Bartrina Campos. 1969. *A case grammar classification of Spanish verbs*. Unpublished doctoral dissertation, University of Michigan, Ann Arbor.
- Malcolm, N. 1958. *Ludwig Wittgenstein. A memoir*. 1st ed., London.
- Masscy, Gerald J. 1970. *Understanding symbolic logic*. New York: Harper and Row.
- Moyne, John Abel. 1970. *The structure of verbal constructions*. Unpublished doctoral dissertation, Harvard University. Cambridge, Mass.

- Nasr, S. H. 1964. An introduction to Islamic cosmological doctrines. Cambridge, Mass.
- Nilsen, Don Lee Fred. 1971. Toward a semantic specification of deep case. Unpublished doctoral dissertation, University of Michigan, Ann Arbor.
- Nye, Gertrude E. 1955. The phonemes and morphemes of modern Persian; a descriptive study. Unpublished doctoral dissertation, University of Michigan, Ann Arbor.
- Palmer, Adrian Shuford. 1970. The czafe construction in modern standard Persian. Unpublished doctoral dissertation, University of Michigan, Ann Arbor.
- Paper, Herbert H. 1959. Review of Lazard, Grammaire du Persan contemporain (1957). Journal of the American Oriental Society. 79. 31-39.
- Phillott, Douglas C. 1919. Higher Persian grammar. Calcutta University.
- Postal, Paul M. 1971. Cross-over phenomena. Holt, Rinehart and Winston, Inc. New York.
- Roberts, Paul. 1964. English syntax. Harcourt, Brace and World, Inc., New York.
- Robinson, Jane J. 1968. "Case, category and configuration." Section III of Specification and utilization of a transformational grammar. Scientific report No. 3, Air Force Contract AF 19(628)-5127.
- _____. 1970. Dependency structures and transformational rules. Language, Vol. 46, #2 (Part 1). The Waverly Press, Inc., Baltimore, Md.
- Sadeghi, A. A. 1969. "næzæriye-e zæbanšenasi-e andre martine væ zæban-e farsi. "mæjæle-e daneškæde-e ædæbiyat væ 'olome ensani. Vol. 17, No. 2. pp. 143-160. Tehran University.
- _____. 1971. Review of Bateni, towsif-e saxteman-e... (1968). Rahnema-e ketab. Vol. 14, No. 1-2-3, pp. 72-83.
- Seiler, Hansjakob. 1960. Relativsatz, Altribut und Apposition. Otto Harrassowitz. Wiesbaden.
- Stilo, Donald L. 1971. A grammar of Vafsi-Tati: an application of a transformational computer model. Unpublished doctoral dissertation, University of Michigan, Ann Arbor.
- Strawson, P. F. 1952. Introduction to logical theory. London: Methuen and co., Ltd.
- Tauer, Felix. 1968. "Persian learned literature from its beginning up to the end of the 18th century." Jan Rypka, History of Iranian literature, pp. 429 ff. D. Reidel Publishing Company, Dordrecht, Holland.
- Telegdi, Za. 1964. Über einen Fall von struktureller Homonymie im Persischen, Acta Linguistica 14.
- Weinreich, Uriel. 1966. "Explorations in semantic theory." T. A. Sebeok, ed. Current trends in linguistics. Vol. 3. Theoretical foundations. The Hague: Mouton and Company. pp. 395-477.

- Windfuhr, Gernot L. [Forthcoming]. Persian and west Iranian dialectology. Series Critica, Mouton & Co.
- Wittgenstein, Ludwig. 1922. *Tractatus Logico-Philosophicus*. Harcourt, Brace and Company, Inc. New York.
- Yar-Shater, Ehsan. 1969. *A grammar of southern Tati dialects*. The Hague/Paris: Mouton.

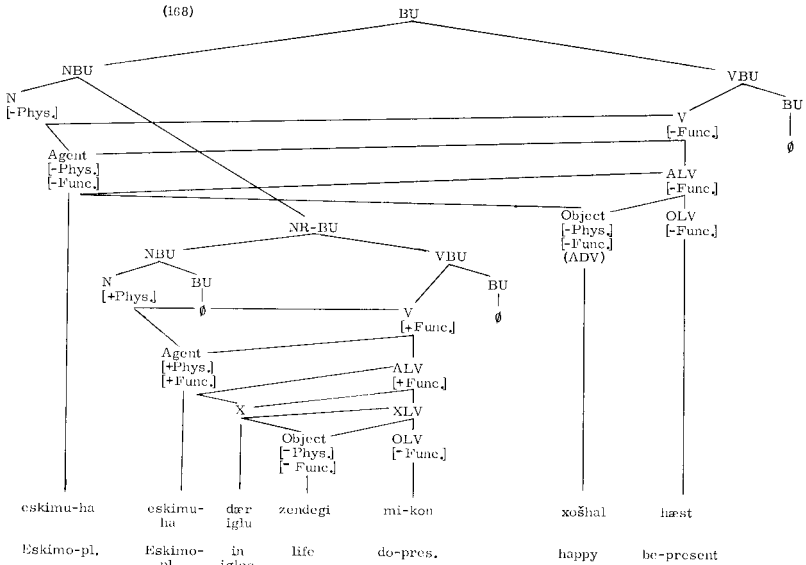

IRAJ BASHIRI

Iraj Bashiri received his undergraduate education at Pahlavi University from which he graduated in 1963, majoring in English language and literature. He received his M.A. in general linguistics and his Ph.D. in Iranian linguistics from the University of Michigan. He has lived and traveled extensively since 1962 in Iran, Great Britain, Canada, and the United States, teaching English and Persian. He is currently Assistant Professor of Iranian linguistics and Turkish at the University of Minnesota. He is the author of *Persian for Beginners*, of which a revised and expanded edition is forthcoming from Bibliotheca Islamica.