

A-WARD™



Distributor of Bramidan Vertical Balers

BRAMIDAN®

BRAND OVERVIEW

THE MARRIAGE OF A-WARD & BRAMIDAN

Bramidan is one of the leading suppliers of waste handling solutions. They develop and produce reliable and user-friendly balers and compactors for cardboard, plastic and other recyclable materials. Their broad product range easily answers the demands of many different businesses. By continuously listening to the market they have built a tradition of providing customers with what they really need.

With any Bramidan product you can expect reliability and efficiency. European designed and manufactured these machines are built to last. After supplying tens of thousands of balers to satisfied customers within many different industries, they have proven that efficient waste handling makes a profitable and visible difference.

At A-Ward, we understand that in business you regularly face new operational challenges. Our priority is to listen to our clients first before responding with innovative answers. We pride ourselves on offering not just products, but solutions for your evolving needs. These solutions are efficiency-creating, user-friendly, safe, robust and always tailored to you and your business.

Our combined know-how and customer focus is exactly why the marriage of A-Ward and Bramidan is the perfect partnership.



CASE STUDY

PPRO

Well-known for its thriftiness, the mission of PAK'n SAVE brand is to provide New Zealand's lowest food prices. This means they are always searching for ways to keep costs down. While they do their best to recycle some of the better cardboard boxes for their customers' use, the majority of their cardboard is left over floating around the back storeroom.

Until recently, PAK'n SAVE's solution to the excess cardboard was three very large council cardboard recycling bins. These bins lined the driveway leading up to the storeroom, taking up a lot of space and often a nuisance for trucks driving up to deliver groceries. Staff had to walk a distance outside, rain or shine, to load the bins. Cardboard was ending up on the ground, and flew down into the stream below - a far cry from the environmentally friendly initiative intended.

It was obvious that something needed to be done to address these issues. The answer was the X50 Bramidan vertical baler. New owner of PAK'n SAVE Henderson, John Smith, had previous experience with a baler machine. The efficiency he witnesses such a machine could create immediately provoked him to look into getting one for his new franchise store. "I believe this machine will pay for itself in less than eight months" says Smith.

Checkout Manager, Nirmala Agrawal, was responsible for getting the entire team, and even visiting sales reps, up skilled on using the baler machine which they like to call the 'Cardboard Crusher'. "Not only is everyone now using the cardboard crusher, they are actually enthusiastic about it. And there are no more pieces of cardboard flying around the storeroom" she says.

The results have been even better than expected. Trucks can now easily get close to the unloading bay. There is also huge time efficiency and happier staff due to the fact that they don't even need to leave the storeroom. "It is just a much easier process" says Agrawal.

"I believe this machine will pay for itself in less than eight months."

John Smith
Owner, PAK'nSAVE Henderson

The bales created by the Bramidan X50 are export-quality. Agrawal goes on to say, "Even beyond all of the other benefits, we can get a much better price for these bales than we ever could from the council bins - it doesn't really compare at all".

PAK'n SAVE Henderson is creating over 25 tonnes of cardboard bales per month selling for around \$130 per tonne. Now fetching \$3,250 per month with the bales is a substantial increase on the \$700 they could get in a good month from the loose cardboard in the council bins.

In such a fast-paced environment like PAK'n SAVE Henderson, hassle-free operations are essential. When owner John Smith was asked about his experience working with A-Ward he said, "A-Ward are just so easy to work with, we have had no issues with the product at all and it is doing exactly what I need it to do - no fuss".

BRAMIDAN X50

FIT

A-WARD
BRAMIDAN

PAKSAVE
SINHA SIVAKUMAR
SINHA SIVAKUMAR
PAKSAVE

24x500g
INTERNAL DIMS
EXTERNAL DIMS
CLEARANCE SURF
NET WEIGHT
GROSS WEIGHT

pears®
RICE
SNAPS

pears®
RICE
SNAPS

24x500g

A-WARD

PRODUCT OVERVIEW

BRAMIDAN VERTICAL BALERS

Bramidan offers two series of vertical balers, the B-Series and the X-Series, for efficient compaction of waste. Both series offer durable, reliable machines with low noise levels and suitability for various waste types.

The difference between the series' lies in the physical design. The B-Series models have a classic design whereby the cylinders sit on top of the machine. These value for money models are suitable if you have plenty of space and more specifically, no height restrictions. The X-Series balers have a compact design for a space saving solution and easy installation. These machines are particularly suitable if you have height restrictions. These models also have an optional fully automatic door.

Multi Chamber Balers are produced with two or more chambers for compacting more waste types at the same time.



Vertical Balers

B-series

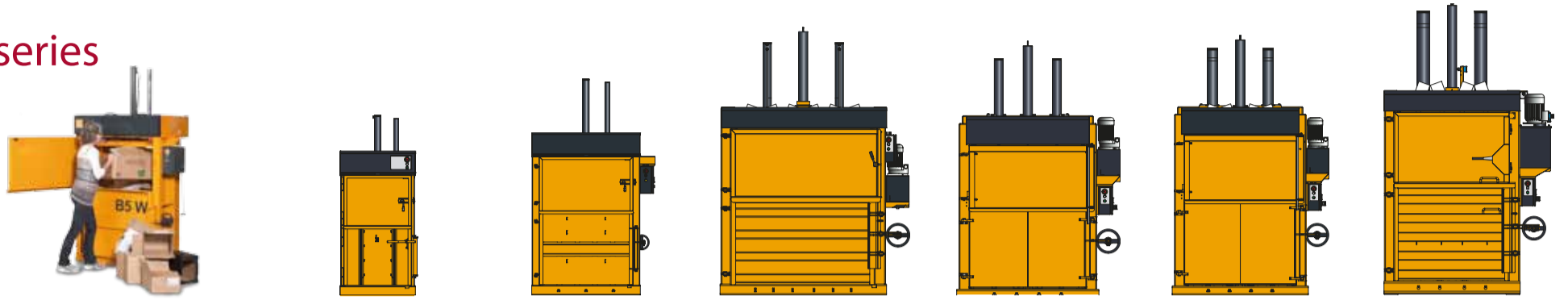

Technical specifications	B3	B5 W	B16 W	B20 ¹⁾	B30 ¹⁾	B50
Press force (t)	3	5	16	20	30	50
Power supply	1x230V 10A	1x230V 10A	3x230/400V 25/16A	3x230/400V 25/16A	3x230/400V 25/16A	3x400V 32A
Noise level (dB)	65-68	65-68	67	62-64	62-64	70-75
Cycle time (sec)	26	33	31	36	55	31
Dimensions WxDxH (mm)	845 x 745 x 1965	1355 x 890 x 2370	2085 x 1070 x 2940	1760 x 1025 x 2770	1765 x 1025 x 2905	1860 x 1075 x 3180
Weight (kg)	310	600	1660	1240	1560	2025
Filling opening WxH (mm)	700 x 460	1000 x 500	1525 x 610	1200 x 550	1200 x 610	1200 x 600
Bale size WxDxH (mm)	700 x 500 x 650	1000 x 700 x 800	1525 x 800 x 950	1200 x 800 x 850	1200 x 800 x 950	1200 x 800 x 1200
Bale weight cardboard (kg)	30-50	80-110	250-300	200-250	280-350	400-500
Bale weight plastic (kg)	40-60	90-130	275-350	250-300	350-450	450-550



Try the Vertical Door ¹⁾ - NEW
A model VD has a vertical door, which gives an ergonomical filling of waste.

- Value for money
- Simple and safe

X-series

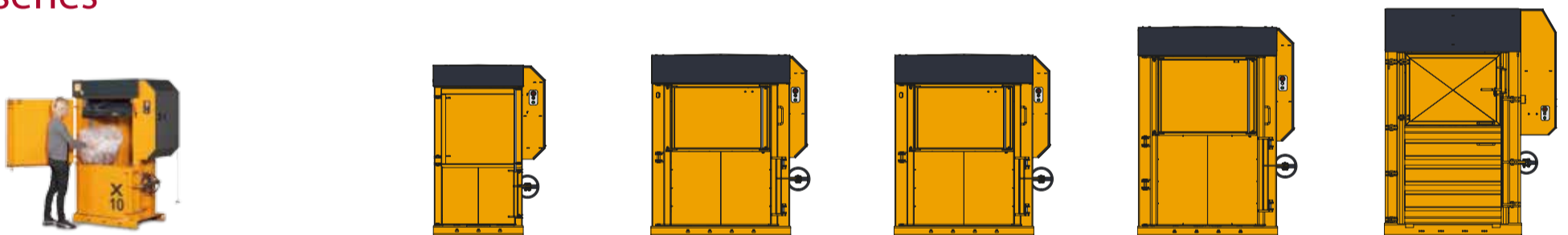

Technical specifications	X10	X16	X25 ²⁾	X30 ²⁾	X50
Press force (t)	10	16	25	30	50
Power supply	3x230/400V 25/16A	3x230/400V 25/16A	3x230/400V 25/16A	3x230/400V 25/16A	3x400V 32A
Noise level (dB)	59-60	59-60	59-60	59-60	71
Cycle time (sec)	12	15	23	25	23
Dimensions WxDxH (mm)	1250 x 1030 x 1900	1745 x 1260 x 1995	1745 x 1260 x 1995	1745 x 1260 x 2295	1950 x 1400 x 2580
Weight (kg)	665	1390	1410	1710	2590
Filling opening WxH (mm)	800 x 610	1090 x 530	1090 x 530	1090 x 655	1090 x 600
Bale size WxDxH (mm)	800 x 600 x 600	1200 x 800 x 800	1200 x 800 x 800	1200 x 800 x 1000	1200 x 800 x 1100
Bale weight cardboard (kg)	70-90	200-250	250-300	280-350	400-450
Bale weight plastic (kg)	80-110	250-300	300-400	350-450	450-550



Try the Automatic Door ²⁾ - NEW
A model AD has a sliding door that closes and opens automatically, giving a quick filling of waste.

- Durable construction
- Fast cycle time
- Low noise level

Bale press

B3

Where space is limited

The B3 is one of the smallest balers in our machine programme. With a base area of only 720 x 820 mm and a 230V connection, it is easy to locate.

To ensure the chamber is not overloaded, the B3 is equipped with a full-indicator which twinkles when the baler is full, and the press plate stays down.

Furthermore the baling process is simplified as the straps can be pulled directly through the main door.

- **Simple and safe operation**
Green light twinkles when chamber is full
- **Easy to replace strap rolls**
They are placed in front
- **Compact design**
With low overall height

BRAMIDAN®

Technical specifications

Press force (t)	3
Power supply	1x230V 50Hz 10A
Motor (kW)	1.1
Noise level (dB)	65-68
Cycle time (sec)	18
Dimensions WxDxH (mm)	850 x 725 x 1965
Weight (kg)	310
Filling opening WxH (mm)	700 x 460
Filling height (mm)	755
Chamber height (mm)	1100
Stroke (mm)	550
Bale size WxDxH (mm)	700 x 500 x 650
Bale weight cardboard (kg)	30-50
Bale weight plastic (kg)	40-60



The baler has a simple control panel and is equipped with easily understood pictograms.



The strap rolls are easy to replace in front of the machine.



Bale press

B4

Handling larger boxes

The B4 is a machine which has been constructed to service users with smaller amounts of waste, but who still need a machine to handle bulky materials.

The machine is characterized by a very wide filling opening of 1 metre, which is an advantage when handling larger cardboard boxes. The chamber is equipped with rows of efficient barbs, which keep the material back and ensure optimum filling.

- **Large filling opening**
 Advantage when handling larger boxes
- **Easy to replace strap rolls**
 They are placed in front
- **Automatic ejection**
 Two-hand operation ejects the bale



BRAMIDAN®

Technical specifications

Press force (t)	4
Power supply	1x230V 50Hz 10A
Motor (kW)	1.1
Noise level (dB)	65-68
Cycle time (sec)	26
Dimensions WxDxH (mm)	1195 x 885 x 2370
Weight (kg)	550
Filling opening WxH (mm)	1000 x 500
Filling height (mm)	915
Chamber height (mm)	1305
Stroke (mm)	750
Bale size WxDxH (mm)	1100 x 700 x 800
Bale weight cardboard (kg)	70-100
Bale weight plastic (kg)	90-120



4



An efficient and strong ejecting system ensures easy handling of the compressed bale.



The strap rolls are easy to replace in front of the machine.

Bale press

B16

Large scale compression

The B16 is a highly flexible machine and can be used in many different situations eg. larger retail shops, stores and different industries.

This baler has a wide filling opening for handling larger boxes, and the chamber is provided with rows of barbs, which keep the waste material down, even very expandable materials.

The B16 is easy to operate and the traditional construction ensures low maintenance costs.

- **Easy to replace strap rolls**
They are placed in front
- **Automatic ejection**
Two-hand operation ejects the bale
- **Large filling opening**
Advantage when handling larger boxes



BRAMIDAN®

Technical specifications

Press force (t)	16
Power supply	3x230/400V 50Hz 25/16A
Motor (kW)	4.0
Noise level (dB)	75-77
Cycle time (sec)	31
Dimensions WxDxH (mm)	1310 x 1000 x 2750
Weight (kg)	1040
Filling opening WxH (mm)	1020 x 530
Filling height (mm)	960
Chamber height (mm)	1375
Stroke (mm)	750
Bale size WxDxH (mm)	1100 x 700 x 850
Bale weight cardboard (kg)	160-200
Bale weight plastic (kg)	180-250



The strap rolls are easy to replace in front of the machine.



All balers are equipped with easily understood pictograms.

Bale press

B16 W

For huge boxes

The B16 Wide is characterized by a very wide filling opening of more than 1.5 metre, which makes it possible to fill in even huge cardboard boxes without folding.

The chamber is equipped with rows of efficient barbs, which keep the material down and ensure optimum filling.

The machine has a full-indicator, which tells you when the chamber is full and ready for baling.

- **Very wide filling opening**
For handling huge boxes
- **Easy to replace strap rolls**
They are placed in front
- **Automatic ejection**
Two-hand operation ejects the bale

BRAMIDAN®

Technical specifications

Press force (t)	16
Power supply	3x230/400V 50Hz 25/16A
Motor (kW)	4.0
Noise level (dB)	67
Cycle time (sec)	31
Dimensions WxDxH (mm)	2085 x 1070 x 2940
Weight (kg)	1660
Filling opening WxH (mm)	1525 x 610
Filling height (mm)	1070
Chamber height (mm)	1560
Stroke (mm)	750
Bale size WxDxH (mm)	1525 x 800 x 950
Bale weight cardboard (kg)	250-300
Bale weight plastic (kg)	275-350



1.



2.



3.



The baler has a simple control panel.



Strap rolls are easy to replace in front of the machine.

Bale press

B30

Handling bulky waste

The B30 is a flexible machine and can be used for waste handling in larger retail shops and different industrial companies.

The wide filling opening makes it easy to fill in larger boxes and other bulky waste. Rows of efficient barbs inside the chamber keep down the waste material, even very expandable materials like plastic.

The B30 is easy to operate and has a full-indicator, which tells you when the chamber is full and ready for baling.

- **Easy to replace strap rolls**
They are placed in front
- **Large filling opening**
For handling bulky waste
- **Automatic ejection**
Two-hand operation ejects the bale

BRAMIDAN®



Technical specifications

Press force (t)	30
Power supply	3x230/400V 50Hz 32/25A
Motor (kW)	4.0
Noise level (dB)	67
Cycle time (sec)	45
Dimensions WxDxH (mm)	1755 x 1070 x 2940
Weight (kg)	1500
Filling opening WxH (mm)	1200 x 610
Filling height (mm)	1070
Chamber height (mm)	1560
Stroke (mm)	750
Bale size WxDxH (mm)	1200 x 800 x 950
Bale weight cardboard (kg)	280-350
Bale weight plastic (kg)	350-450



1.



2.



3.



Strap rolls are easy to replace in front of the machine.



Rows of barbs inside the chamber keep the waste material down.

Bale press

B50

Heavy duty compression

The B50 can be used in larger retail shops and various industrial companies. It has a strong press force and is designed for efficient waste handling of cardboard and dry soft plastic.

The wide filling opening makes it easy to fill in larger boxes and other bulky waste. Rows of efficient barbs inside the chamber keep down the waste material, even very expandable materials like dry soft plastic.

- **Automatic ejection**
Two-handed operation ejects the bale
- **Large filling opening**
for handling bulky waste materials
- **Safe and steady opening of door**
Operated by a strong threaded spindle

BRAMIDAN®

Technical specifications

Press force (t)	50
Power supply	3x400V 50Hz 32A
Motor (kW)	5.5
Noise level (dB)	70-75
Cycle time (sec)	31
Dimensions WxDxH (mm)	1860 x 1075 x 3180
Weight (kg)	2100
Filling opening WxH (mm)	1200 x 600
Filling height (mm)	1210
Chamber height (mm)	1665
Stroke (mm)	900
Bale size WxDxH (mm)	1200 x 800 x 1100
Bale weight cardboard (kg)	400-500
Bale weight plastic (kg)	450-550



Strap rolls are easy to replace in front of the machine.



The machine has a simple control panel.

Bale press X12

Limited space for waste

The X12 is suitable for smaller retail shops, industrial companies or other companies, who need a compact baler with high capacity. The compact design makes it ideal where space is limited.

Equipped with cross cylinders, this machine offers superior press force but also a very low overall height. The X12 has a relatively large filling opening, making the daily operation as easy as possible.

- **Easy installation**
Very low overall height
- **Safe and steady opening of door**
Operated by a strong threaded spindle
- **Automatic ejection**
Two-hand operation ejects the bale

BRAMIDAN®



Technical specifications

Press force (t)	12
Power supply	3x230/400V 50Hz 25/16A
Motor (kW)	4.0
Noise level (dB)	68
Cycle time (sec)	18
Dimensions WxDxH (mm)	1250 x 775 x 1890
Weight (kg)	810
Filling opening WxH (mm)	715 x 600
Filling height (mm)	735
Chamber height (mm)	1225
Stroke (mm)	780
Bale size WxDxH (mm)	800 x 600 x 600
Bale weight cardboard (kg)	80-100
Bale weight plastic (kg)	100-120



1.



2.



3.



The bale is ejected by a safe two-hand operation.



The cross cylinders ensure stable compression and a low overall height.

Bale press

X16

Rational waste handling

The X16 is equipped with cross cylinders, thus the machine offers superior press force but also a very low overall height. Combined with a long stroke, a high bale weight can be achieved.

This baler is designed with easy servicing in mind, for example the positioning of the hydraulic unit mounted next to the control panel on the side of the machine.

- **Noiseless**
Due to an unique hydraulic system
- **Easy installation**
Very low overall height
- **Safe and steady opening of door**
Operated by a strong threaded spindle

BRAMIDAN®



Technical specifications

Press force (t)	16
Power supply	3x230/400V 50Hz 25/16A
Motor (kW)	4.0
Noise level (dB)	67
Cycle time (sec)	22
Dimensions WxDxH (mm)	1715 x 1290 x 1995
Weight (kg)	1260
Filling opening WxH (mm)	1090 x 530
Filling height (mm)	950
Chamber height (mm)	1375
Stroke (mm)	955
Bale size WxDxH (mm)	1200 x 800 x 800
Bale weight cardboard (kg)	200-250
Bale weight plastic (kg)	250-300



1.



2.



3.



The bale is ejected by a safe two-hand operation.



The cross cylinders ensure stable compression and a low overall height.

Bale press X25

For larger demands

The X25 is equipped with cross cylinders, giving you stable compression and superior press force, together with a low overall height. Combined with a long stroke, a high bale weight can be achieved.

This baler is designed with easy servicing in mind, for example the positioning of the hydraulic unit mounted next to the control panel on the side of the machine.

- **Noiseless**
Due to an unique hydraulic system
- **Safe and steady opening of door**
Operated by a strong threaded spindle
- **Easy installation**
Very low overall height

BRAMIDAN®



Technical specifications

Press force (t)	25
Power supply	3x230/400V 50Hz 25/16A
Motor (kW)	4.0
Noise level (dB)	67
Cycle time (sec)	32
Dimensions WxDxH (mm)	1715 x 1290 x 1995
Weight (kg)	1280
Filling opening WxH (mm)	1090 x 530
Filling height (mm)	950
Chamber height (mm)	1375
Stroke (mm)	955
Bale size WxDxH (mm)	1200 x 800 x 800
Bale weight cardboard (kg)	250-300
Bale weight plastic (kg)	300-400



1.



2.



3.



A threaded spindle ensures steady and safe opening of the main door.



The cross cylinders ensure stable compression and a low overall height.

Bale press X30

Handling bulky waste

The X30 is suitable for retail shops and industrial companies with large quantities of waste. It is a compact machine with high capacity and superior press force.

This baler has a very wide filling opening for handling larger boxes, making the daily operation as easy as possible. The finished bale can be tied with flat straps or steel wires.

- **Noiseless**
Due to an unique hydraulic system
- **Easy installation**
Very low overall height
- **Safe and steady opening of door**
Operated by a strong threaded spindle



BRAMIDAN®



Technical specifications

Press force (t)	30
Power supply	3x230/400V 50Hz 25/16A
Motor (kW)	4.0
Noise level (dB)	67
Cycle time (sec)	34
Dimensions WxDxH (mm)	1715 x 1330 x 2295
Weight (kg)	1710
Filling opening WxH (mm)	1090 x 600
Filling height (mm)	1145
Chamber height (mm)	1650
Stroke (mm)	925
Bale size WxDxH (mm)	1200 x 800 x 1000
Bale weight cardboard (kg)	280-350
Bale weight plastic (kg)	350-450



The bale is ejected by a safe two-hand operation.



The cross cylinders ensure stable compression and a low overall height.

Bale press X50

Heavy duty compression

The X50 is designed for users, who demand a high quality machine with focus on reliability, superior press force, and a safe, functional working environment for the operator.

It has a large filling opening and a fast cycle time, making the daily operation as rational as possible.

- **Effective operation**
Due to a fast cycle time
- **Easy installation**
With a low overall height
- **Safe and steady opening of door**
Operated by a strong threaded spindle

BRAMIDAN®

Technical specifications

Press force (t)	50
Power supply	3x400V 50Hz 32A
Motor (kW)	5.5
Noise level (dB)	71
Cycle time (sec)	23
Dimensions WxDxH (mm)	1950 x 1400 x 2580
Weight (kg)	2500
Filling opening WxH (mm)	1090 x 600
Filling height (mm)	1250
Chamber height (mm)	1700
Stroke (mm)	1210
Bale size WxDxH (mm)	1200 x 800 x 1100
Bale weight cardboard (kg)	400-450
Bale weight plastic (kg)	450-550



1.



2.



3.



The bale is ejected by a safe two-hand operation.



The cross cylinders ensure stable compression and a low overall height.

Bale press

MC16

Large multi chamber baler

The MC16 multi chamber baler has been designed to serve customers with larger quantities of waste and a demand for sorting waste.

The standard machine is supplied with two chambers, but additional chambers can be added, when sorting several waste types.

- **Effective operation**
With a fast cycle time
- **Easy move of press section**
Due to horizontal handle
- **Automatic ejection**
Two-hand operation ejects the bale



1.



2.



3.

BRAMIDAN®



Technical specifications

Press force (t)	16
Power supply	3x230/400V 50Hz 25/16A
Motor (kW)	4.0
Noise level (dB)	68-72
Cycle time (sec)	26
Dimensions WxDxH (mm)	2540 x 1210 x 2570
Weight (kg)	1655
Filling opening WxH (mm)	1100 x 700
Filling height (mm)	1420
Chamber height (mm)	-
Stroke (mm)	650
Bale size WxDxH (mm)	1100 x 700 x 800
Bale weight cardboard (kg)	160-200
Bale weight plastic (kg)	180-250



Rubber shock absorbers ensure a noiseless move of the press section.



The horizontal handle gives an ergonomic working posture.

Special machine BP2

Compress wet waste

The bag press BP2 compacts waste inside a steel chamber enclosed by a plastic bag, preventing the bag from busting. The press is especially suitable for cardboard, plastic and cans, and for wet waste.

You can easily move the press due to the wheels, which can be locked with a brake. The daily operation is simple and you can quickly change the plastic bag.

The surface treatment is hot galvanization, making the bag press resistant in aggressive environments.



1.

- **Compact design**
Low overall height, only 185 cm
- **Long-lasting**
Galvanized, resistant surface
- **Effective operation**
Due to a fast cycle time

BRAMIDAN®



Technical specifications

Press force (t)	1.5
Power supply	1x230V 50Hz 10A
Motor (kW)	0.75
Noise level (dB)	-
Cycle time (sec)	25
Dimensions WxDxH (mm)	1000 x 600 x 1800
Weight (kg)	220
Filling opening WxH (mm)	Ø 430
Filling height (mm)	1000
Chamber height (mm)	660
Stroke (mm)	600
Bale size WxDxH (mm)	-
Bale weight cardboard (kg)	-
Bale weight plastic (kg)	-



2.



3.



You can easily move the bag press due to its wheels, which can be locked with a brake.



Compression inside a galvanized steel chamber prevents the bags from busting.