

ROTAX 377 UL - 35 HP

(Please Note: The ROTAX 377 Engine is No Longer in Production)

35 hp @ 6500

2 Cylinder / 2 Stroke Piston Ported

35 hp @ 6500
2 Cylinder / 2 Stroke Piston Ported

Bore/Stroke: 62/61mm

Displacement: 368.3

Ignition System: Bosch Flywheel Magneto

Generator 12V 110 W + 30W

Carburetor: 36mm Bing Double Float Carburetor

with hand lever or alternatively cable choke

Starter: Rewind or Electric

Cooling: Free Air or Fan Cooled

Lubrication: 2 stroke oil in fuel; mixing ratio: 50:1

Fuel: Premium unleaded NOT BELOW MON 88

OR RON 90 (octane rating)

Description	Weight
Block F.C.	60.6 lbs.
Carburetor	2.5 lbs.
Exhaust	11.0 lbs.
Redrive	10.5 lbs.
Total	84.6 lbs.

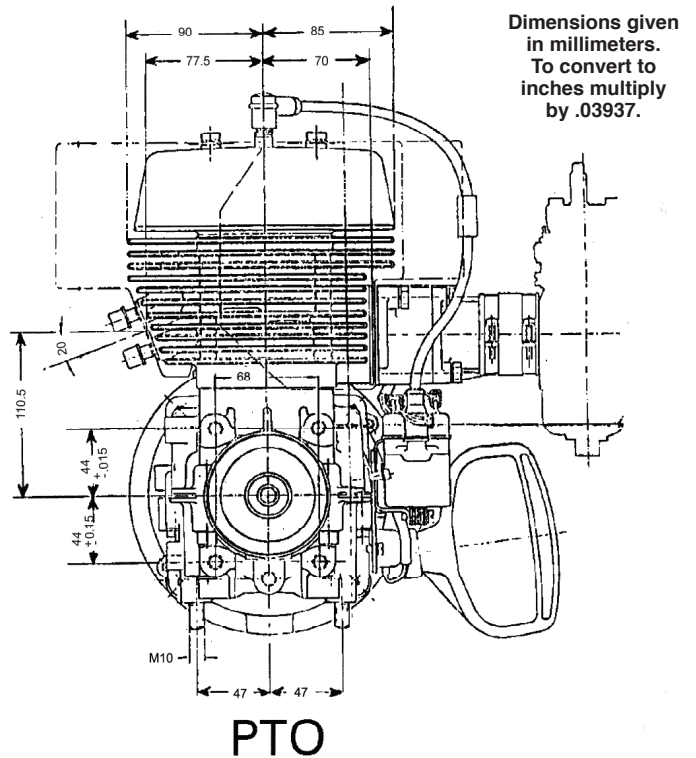
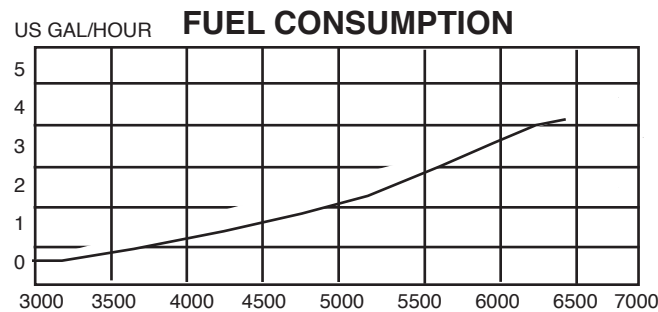
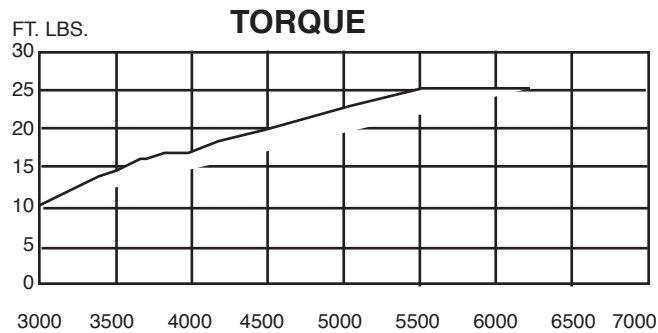
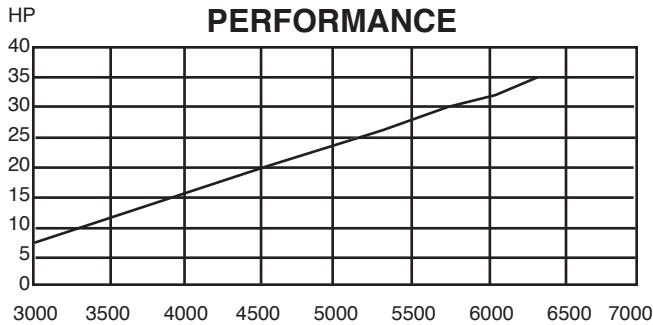
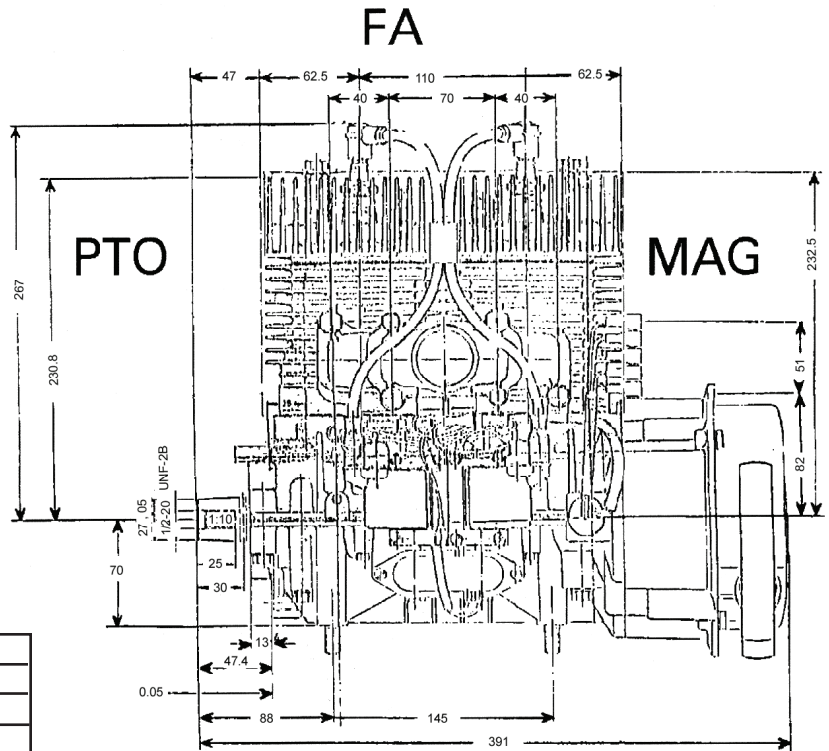

independent SERVICE CENTRE

ROTAX
AIRCRAFT ENGINES

LEADING EDGE AIR FOILS, LLC 1-800-532-3462 info@leadingedgeairfoils.com
www.leadingedgeairfoils.com store.leadingedgeairfoils.com