

QRS11

MEMS Quartz Angular Rate Sensor

Ideal for High-Precision Military Applications:

- Platform Stabilization & Pointing
- Guidance & Control
- Instrumentation
- Navigation
- Standby Attitude Indicator Systems
- **Over 250,000 QRS11's in the field!**



Key Performance Features:

- **DC Input/High Level DC Output**
- **Extremely Low Noise**
- **Outstanding Bias Stability**
- **High MTBF**
- **Fast Start-Up**
- **Long Life**



The QRS11 is built with MEMS technology to deliver highly stable long-life performance in a small, lightweight package. With no moving parts, the quartz sensing element has a virtually unlimited life while providing outstanding signal to noise performance. In production since 1991, the QRS11 provides reliable angular rate data in numerous aircraft, missile, space and commercial systems.

The QRS11 is exceptionally small and consumes very little power, plus it's self-contained and extremely lightweight. For rocket, missile and other munitions – plus space applications, the QRS11 has been ruggedized to typical boost environments, is radiation tested for total dose and single event upset (SEU) events, and qualified by more than 7 million failure-free “fleet-wide” operating hours in critical applications.

QRS11

MEMS Quartz Angular Rate Sensor

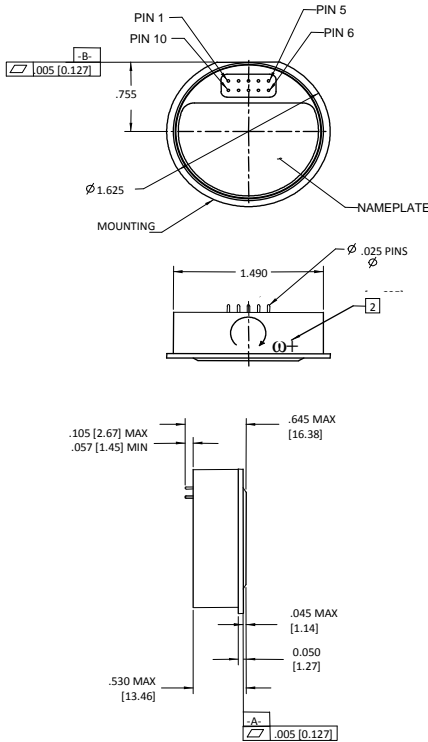

Notes:

1. QRS11 is supplied with two mounting rings, mounting screws & mating test connector.
2. Angular rate applied as shown will produce a more positive output (not marked on unit)
3. Unit of measure is inches [millimeters]
4. A DC voltage input of (± 1.0 Vdc Max) applied to the self-test will result in a proportional DC output voltage
5. TTL compatible BIT output signal of ≥ 2.4 Vdc (referenced to power ground) indicates a properly functioning unit.

QRS11 INPUTS/OUTPUTS

Self Test Input (see Note 4)
 +Vdc Input
 Power Ground
 BIT Output (see Note 5)
 Internal Temperature Sensor
 Rate Output
 Signal Ground
 -Vdc Input
 Case Ground

	QRS11-00100-100	QRS11-00100-101
Performance Level	Standard	High
Power Requirements		
Input Voltage	+ & - 5Vdc $\pm 3\%$ regulation	
Input Current	≤ 80 mA (each supply)	
Input Power Noise Limits	< 10 mV _{rms} wideband, except at 8.7 ± 0.5 kHz, < 1 mV _{rms}	
Performance		
Standard Range Full Scale	$\pm 100^\circ/\text{sec.}$	
Full Scale Output (Nominal)	± 2.5 Vdc	
Scale Factor Calibration (at 22°C Typical)	$\leq 1\%$ of value	
Scale Factor Over Temperature (Dev. from 22°C Typical)	$\leq 0.03\%/^\circ\text{C}$	
Bias Calibration (at 22°C Typical)	$\leq 2.0^\circ/\text{sec.}^*$	$\leq 0.5^\circ/\text{sec.}^*$
Bias Variation over Temperature (Dev. from 22°C)	$\leq 1.80^\circ/\text{sec.}^*$	$\leq 0.35^\circ/\text{sec.}^*$
Short Term Bias Stability (100 sec at const. temp)	$< 0.01^\circ/\text{sec.}$, typical*	
Long Term Bias Stability (1 year)	$\leq 0.2^\circ/\text{sec.}^*$	
G Sensitivity (Typical)	$\leq 0.02^\circ/\text{sec}/\text{g}$	
Start-Up Time (Typical)	< 1 sec.	
Bandwidth (-90° Phase Shift)	> 60 Hz	
Non-Linearity (Typical) % Full Range	$\leq 0.05\%$	
Threshold/Resolution	$\leq 0.004^\circ/\text{sec.}^*$	
Output Noise (DC to 100 Hz)	$\leq 0.01^\circ/\text{sec.}/\sqrt{\text{Hz}}^*$	
Environments		
Operating Temperature	-40°C to $+80^\circ\text{C}$	
Storage Temperature	-55°C to $+100^\circ\text{C}$	
Vibration Operating**	8 g _{rms} 20 Hz to 2 kHz Random (Consult factory for other vibration level requirements)	
Vibration Survival**	20 g _{rms} 20 Hz to 2 kHz random 5 minutes/axis	
Shock	200g, any axis	
Weight	≤ 60 grams	
Available Options		
<ul style="list-style-type: none"> • Special Non-Standard Ranges $< \pm 100^\circ/\text{sec.}$ & $> \pm 100^\circ/\text{sec.}$, Consult Factory • Extended Bandwidth • Flying Leads • Low Noise • Extended Temperature Range 		

* Values indicated are for $\pm 100^\circ/\text{sec.}$ range

** Please see user's guide for more information regarding vibration tolerance and sensitivity.

For more information, contact:

Systron Donner Inertial
 2700 Systron Drive
 Concord, CA 94518 USA
 +1.866.234.4976 | sales@systron.com

www.systron.com

A brand of
CST
 CUSTOM SENSORS & TECHNOLOGIES

964001 Rev. K