



**Digital Video Broadcasting (DVB);  
Frame structure channel coding and modulation  
for a second generation digital terrestrial  
television broadcasting system (DVB-T2)**

**DVB Document A122**

**July 2011**



---

# Contents

Intellectual Property Rights .....	7
Foreword.....	7
1 Scope .....	8
2 References .....	8
2.1 Normative references .....	8
2.2 Informative references .....	8
3 Definitions, symbols and abbreviations .....	9
3.1 Definitions .....	9
3.2 Symbols .....	12
3.3 Abbreviations.....	16
4 DVB-T2 System architecture .....	17
4.1 System overview.....	17
4.2 System architecture.....	19
4.3 Target performance.....	21
5 Input processing .....	22
5.1 Mode adaptation .....	22
5.1.1 Input Formats .....	22
5.1.2 Input Interface .....	23
5.1.3 Input Stream Synchronization (Optional) .....	23
5.1.4 Compensating Delay for Transport Streams .....	24
5.1.5 Null Packet Deletion (optional, for TS only, NM and HEM) .....	24
5.1.6 CRC-8 encoding (for GFPS and TS, NM only) .....	25
5.1.7 Baseband Header (BBHEADER) insertion.....	25
5.1.8 Mode adaptation sub-system output stream formats .....	26
5.2 Stream adaptation .....	29
5.2.1 Scheduler.....	30
5.2.2 Padding.....	30
5.2.3 Use of the padding field for in-band signalling .....	30
5.2.3.1 In-band type A.....	31
5.2.3.2 In-band type B.....	33
5.2.4 BB scrambling.....	34
6 Bit-interleaved coding and modulation .....	35
6.1 FEC encoding .....	35
6.1.1 Outer encoding (BCH) .....	36
6.1.2 Inner encoding (LDPC).....	38
6.1.2.1 Inner coding for normal FECFRAME .....	38
6.1.2.2 Inner coding for short FECFRAME .....	39
6.1.3 Bit Interleaver (for 16-QAM, 64-QAM and 256-QAM) .....	40
6.2 Mapping bits onto constellations .....	41
6.2.1 Bit to cell word de-multiplexer .....	42
6.2.2 Cell word mapping into I/Q constellations.....	45
6.3 Constellation Rotation and Cyclic Q Delay .....	50
6.4 Cell Interleaver .....	50
6.5 Time Interleaver.....	52
6.5.1 Mapping of Interleaving Frames onto one or more T2-frames .....	54
6.5.2 Division of Interleaving frames into Time Interleaving Blocks .....	54
6.5.3 Interleaving of each TI-block.....	55
6.5.4 Using the three Time Interleaving options with sub-slicing.....	57
6.5.5 PLPs for which Time Interleaving is not used .....	59
7 Generation, coding and modulation of Layer 1 signalling.....	59
7.1 Introduction.....	59
7.2 L1 signalling data .....	60

7.2.1	P1 Signalling data .....	60	
7.2.2	L1-Pre Signalling data .....	62	
7.2.3	L1-post signalling data .....	66	
7.2.3.1	Configurable L1-post signalling .....	66	
7.2.3.2	Dynamic L1-post signalling .....	72	
7.2.3.3	Repetition of L1-post dynamic data .....	73	
7.2.3.4	L1-post extension field .....	74	
7.2.3.4.1	Padding L1-post extension blocks .....	75	
7.2.3.5	CRC for the L1-post signalling .....	75	
7.2.3.6	L1 padding .....	75	
7.2.3.7	L1 bias balancing bits .....	75	
7.3	Modulation and error correction coding of the L1 data .....	76	
7.3.1	Overview .....	76	
7.3.1.1	Error correction coding and modulation of the L1-pre signalling .....	76	
7.3.1.2	Error correction coding and modulation of the L1-post signalling .....	76	
7.3.2	Scrambling and FEC Encoding .....	78	
7.3.2.1	Scrambling of L1-post information bits .....	78	
7.3.2.2	Zero padding of BCH information bits .....	78	
7.3.2.3	BCH encoding .....	80	
7.3.2.4	LDPC encoding .....	80	
7.3.2.5	Puncturing of LDPC parity bits .....	80	
7.3.2.6	Removal of zero padding bits .....	81	
7.3.2.7	Bit interleaving for L1-post signalling .....	82	
7.3.3	Mapping bits onto constellations .....	82	
7.3.3.1	Demultiplexing of L1-post signalling .....	82	
7.3.3.2	Mapping into I/Q constellations .....	83	
7.3.3.3	Modification of L1 signalling constellations by L1-ACE algorithm .....	83	
8	Frame Builder .....	85	
NOTE:	The frame structure and associated parameters are modified for T2-Lite – see annex I.8.1 .....	Frame structure	85
8.2	Super-frame .....	85	
8.3	T2-Frame .....	86	
8.3.1	Duration of the T2-Frame .....	86	
8.3.2	Capacity and structure of the T2-frame .....	87	
8.3.3	Signalling of the T2-frame structure and PLPs .....	90	
8.3.4	Overview of the T2-frame mapping .....	90	
8.3.5	Mapping of L1 signalling information to P2 symbol(s) .....	91	
8.3.6	Mapping the PLPs .....	93	
8.3.6.1	Allocating the cells of the Interleaving Frames to the T2-Frames .....	93	
8.3.6.2	Addressing of OFDM cells .....	94	
8.3.6.3	Mapping the PLPs to the data cell addresses .....	95	
8.3.6.3.1	Insertion of bias balancing cells .....	95	
8.3.6.3.2	Mapping the Common and Type 1 PLPs .....	97	
8.3.6.3.3	Mapping the Type 2 PLPs .....	97	
8.3.7	Auxiliary stream insertion .....	98	
8.3.8	Dummy cell insertion .....	99	
8.3.9	Insertion of unmodulated cells in the Frame Closing Symbol .....	99	
8.4	Future Extension Frames (FEF) .....	99	
8.5	Frequency interleaver .....	100	
9	OFDM Generation .....	105	
9.1	MISO Processing .....	105	
9.2	Pilot insertion .....	106	
9.2.1	Introduction .....	106	
9.2.2	Definition of the reference sequence .....	106	
9.2.2.1	Symbol level .....	107	
9.2.2.2	Frame level .....	107	
9.2.3	Scattered pilot insertion .....	108	
9.2.3.1	Locations of the scattered pilots .....	108	
9.2.3.2	Amplitudes of the scattered pilots .....	110	
9.2.3.3	Modulation of the scattered pilots .....	110	
9.2.4	Continual pilot insertion .....	110	

9.2.4.1	Locations of the continual pilots.....	110
9.2.4.2	Locations of additional continual pilots in extended carrier mode .....	111
9.2.4.3	Amplitudes of the Continual Pilots.....	111
9.2.4.4	Modulation of the Continual Pilots.....	111
9.2.5	Edge pilot insertion .....	111
9.2.6	P2 pilot insertion .....	111
9.2.6.1	Locations of the P2 pilots .....	111
9.2.6.2	Amplitudes of the P2 pilots .....	112
9.2.6.3	Modulation of the P2 pilots .....	112
9.2.7	Insertion of frame closing pilots.....	112
9.2.7.1	Locations of the frame closing pilots.....	113
9.2.7.2	Amplitudes of the frame closing pilots.....	113
9.2.7.3	Modulation of the frame closing pilots.....	113
9.2.8	Modification of the pilots for MISO .....	113
9.3	Dummy tone reservation.....	114
9.4	Mapping of data cells to OFDM carriers .....	115
9.5	IFFT - OFDM Modulation.....	115
9.6	PAPR Reduction .....	117
9.6.1	Active Constellation Extension .....	117
9.6.2	PAPR reduction using tone reservation.....	119
9.6.2.1	Algorithm of PAPR reduction using tone reservation .....	120
9.7	Guard interval insertion .....	122
9.8	P1 Symbol insertion.....	122
9.8.1	P1 Symbol overview .....	122
9.8.2	P1 Symbol description .....	122
9.8.2.1	Carrier Distribution in P1 symbol.....	123
9.8.2.2	Modulation of the Active Carriers in P1 .....	124
9.8.2.3	Boosting of the Active Carriers .....	126
9.8.2.4	Generation of the time domain P1 signal.....	127
9.8.2.4.1	Generation of the main part of the P1 signal.....	127
9.8.2.4.2	Frequency Shifted repetition in Guard Intervals .....	127
10	Spectrum characteristics.....	127
<b>Annex A (normative): Addresses of parity bit accumulators for <math>N_{Idpc} = 64\ 800</math> .....</b>		<b>130</b>
<b>Annex B (normative): Addresses of parity bit accumulators for <math>N_{Idpc} = 16\ 200</math>.....</b>		<b>137</b>
<b>Annex C (normative): Additional Mode Adaptation tools .....</b>		<b>140</b>
C.1	Input stream synchronizer .....	140
C.1.1	Receiver Buffer Model .....	142
C.1.2	Requirements of input signal .....	144
<b>Annex D (normative): Splitting of input MPEG-2 TSs into the data PLPs and common PLP of a group of PLPs.....</b>		<b>146</b>
D.1	Overview .....	146
D.2	Splitting of input TS into a TSPS stream and a TSPSC stream .....	147
D.2.1	General.....	147
D.2.2	TS packets that are co-timed and identical on all input TSs of the group before the split .....	148
D.2.3	TS packets carrying Service Description Table (SDT) and not having the characteristics of category (1) ...	148
D.2.4	TS packets carrying Event Information Table (EIT) and not having the characteristics of category (1).....	149
D.2.4.1	Required operations.....	149
D.2.4.2	Conditions .....	149
D.3	Receiver Implementation Considerations .....	151
<b>Annex E (informative): T2-frame structure for Time-Frequency Slicing.....</b>		<b>152</b>
E.1	General .....	152
E.2	T2-frame structure.....	153

E.2.1	Duration and capacity of the T2-frame .....	153
E.2.2	Overall structure of the T2-frame .....	153
E.2.3	Structure of the Type-2 part of the T2-frame.....	154
E.2.4	Restrictions on frame structure to allow tuner switching time.....	155
E.2.5	Signalling of the dynamic parameters in a TFS configuration.....	156
E.2.6	Indexing of RF channels .....	156
E.2.7	Mapping the PLPs.....	157
E.2.7.1	Mapping the Common and Type 1 PLPs .....	157
E.2.7.2	Mapping the Type 2 PLPs .....	157
E.2.7.2.1	Allocating the cells of the Interleaving Frame to the T2-Frames .....	157
E.2.7.2.2	Size of the sub-slices .....	158
E.2.7.2.3	Allocation of cell addresses to the sub-slices on RF <sub>start</sub> .....	159
E.2.7.2.4	Allocation of cell addresses to the sub-slices on the other RF channels.....	159
E.2.7.2.5	Mapping the PLP cells to the allocated cell addresses .....	161
E.2.8	Auxiliary streams and dummy cells.....	161
<b>Annex F (normative): Calculation of the CRC word .....</b>		<b>162</b>
<b>Annex G (normative): Locations of the continual pilots .....</b>		<b>163</b>
<b>Annex H (normative): Reserved carrier indices for PAPR reduction .....</b>		<b>167</b>
<b>Annex I (normative): T2-Lite .....</b>		<b>169</b>
I.1	Overview .....	169
I.2	In-band signalling.....	169
I.3	FEC encoding for T2-Lite .....	169
I.4	Bit to cell word de-multiplexer .....	170
I.5	Modulation limitations for T2-Lite .....	171
I.6	T2-Lite L1-signalling .....	171
I.7	T2-Lite mode limitations.....	172
I.7.1	FFT size limitations .....	172
I.7.2	Pilot pattern limitations.....	172
I.7.3	Limitations on mode combinations.....	172
I.8	T2-Lite time interleaver memory .....	172
I.9	T2-Lite signal structure .....	173
I.10	T2-Lite PLP data rate limitations .....	173
I.11	T2-Lite receiver buffer model limitations .....	174
<b>Annex J (informative): Transport Stream regeneration and clock recovery using ISCR.....</b>		<b>175</b>
<b>Annex K (informative): Pilot patterns.....</b>		<b>176</b>
<b>Annex L (informative): Allowable sub-slicing values.....</b>		<b>184</b>
<b>Annex M (informative): Bibliography .....</b>		<b>186</b>
History .....		187

---

## Intellectual Property Rights

IPRs essential or potentially essential to the present document may have been declared to ETSI. The information pertaining to these essential IPRs, if any, is publicly available for **ETSI members and non-members**, and can be found in ETSI SR 000 314: "*Intellectual Property Rights (IPRs); Essential, or potentially Essential, IPRs notified to ETSI in respect of ETSI standards*", which is available from the ETSI Secretariat. Latest updates are available on the ETSI Web server (<http://webapp.etsi.org/IPR/home.asp>).

Pursuant to the ETSI IPR Policy, no investigation, including IPR searches, has been carried out by ETSI. No guarantee can be given as to the existence of other IPRs not referenced in ETSI SR 000 314 (or the updates on the ETSI Web server) which are, or may be, or may become, essential to the present document.

---

## Foreword

This European Standard (EN) has been produced by Joint Technical Committee (JTC) Broadcast of the European Broadcasting Union (EBU), Comité Européen de Normalisation ELECTrotechnique (CENELEC) and the European Telecommunications Standards Institute (ETSI).

NOTE: The EBU/ETSI JTC Broadcast was established in 1990 to co-ordinate the drafting of standards in the specific field of broadcasting and related fields. Since 1995 the JTC Broadcast became a tripartite body by including in the Memorandum of Understanding also CENELEC, which is responsible for the standardization of radio and television receivers. The EBU is a professional association of broadcasting organizations whose work includes the co-ordination of its members' activities in the technical, legal, programme-making and programme-exchange domains. The EBU has active members in about 60 countries in the European broadcasting area; its headquarters is in Geneva.

European Broadcasting Union  
 CH-1218 GRAND SACONNEX (Geneva)  
 Switzerland  
 Tel: +41 22 717 21 11  
 Fax: +41 22 717 24 81

The Digital Video Broadcasting Project (DVB) is an industry-led consortium of broadcasters, manufacturers, network operators, software developers, regulatory bodies, content owners and others committed to designing global standards for the delivery of digital television and data services. DVB fosters market driven solutions that meet the needs and economic circumstances of broadcast industry stakeholders and consumers. DVB standards cover all aspects of digital television from transmission through interfacing, conditional access and interactivity for digital video, audio and data. The consortium came together in 1993 to provide global standardisation, interoperability and future proof specifications.

<b>National transposition dates</b>	
Date of adoption of this EN:	3 February 2011
Date of latest announcement of this EN (doa):	31 May 2011
Date of latest publication of new National Standard or endorsement of this EN (dop/e):	30 November 2011
Date of withdrawal of any conflicting National Standard (dow):	30 November 2011

---

# 1 Scope

The present document describes a second generation baseline transmission system for digital terrestrial television broadcasting. It specifies the channel coding/modulation system intended for digital television services and generic data streams.

The scope is as follows:

- it gives a general description of the Baseline System for digital terrestrial TV;
- it specifies the digitally modulated signal in order to allow compatibility between pieces of equipment developed by different manufacturers. This is achieved by describing in detail the signal processing at the modulator side, while the processing at the receiver side is left open to different implementation solutions. However, it is necessary in this text to refer to certain aspects of reception.

Versions 1.1.1 and 1.2.1 of this specification defined a single profile which incorporates time-slicing but not time-frequency-slicing (TFS). Features which would allow a possible future implementation of TFS (for receivers with two tuners/front-ends) can be found in annex E. It is not intended that a receiver with a single tuner should support TFS.

The present document (version 1.3.1 of this specification) adds a T2-Lite profile. This profile is intended to allow simpler receiver implementations for very low capacity applications such as mobile broadcasting, although it may also be received by conventional stationary receivers. The details of this T2-Lite profile are described in annex I. Version 1.3.1 also introduces a name, which is 'T2-base profile', for the previous single profile.

---

# 2 References

References are either specific (identified by date of publication and/or edition number or version number) or non-specific. For specific references, only the cited version applies. For non-specific references, the latest version of the reference document (including any amendments) applies.

Referenced documents which are not found to be publicly available in the expected location might be found at <http://docbox.etsi.org/Reference>.

NOTE: While any hyperlinks included in this clause were valid at the time of publication ETSI cannot guarantee their long term validity.

## 2.1 Normative references

The following referenced documents are necessary for the application of the present document.

- [1] ETSI TS 101 162: "Digital Video Broadcasting (DVB); Allocation of Service Information (SI) and Data Broadcasting Codes for Digital Video Broadcasting (DVB) systems".
- [2] ETSI TS 102 992: "Digital Video Broadcasting (DVB); Structure and modulation of optional transmitter signatures (T2-TX-SIG) for use with the DVB-T2 second generation digital terrestrial television broadcasting system".

## 2.2 Informative references

The following referenced documents are not necessary for the application of the present document but they assist the user with regard to a particular subject area.

- [i.1] ISO/IEC 13818-1: "Information technology - Generic coding of moving pictures and associated audio information: Systems".



- [i.2] ETSI TS 102 606: "Digital Video Broadcasting (DVB); Generic Stream Encapsulation (GSE) Protocol".
- [i.3] ETSI EN 302 307: "Digital Video Broadcasting (DVB); Second generation framing structure, channel coding and modulation systems for Broadcasting, Interactive Services, News Gathering and other broadband satellite applications (DVB-S2)".
- [i.4] ETSI EN 300 468: "Digital Video Broadcasting (DVB); Specification for Service Information (SI) in DVB systems".
- [i.5] ETSI EN 300 744: "Digital Video Broadcasting (DVB); Framing structure, channel coding and modulation for digital terrestrial television".

---

## 3 Definitions, symbols and abbreviations

### 3.1 Definitions

For the purposes of the present document, the following terms and definitions apply:

**0xkk:** digits 'kk' should be interpreted as a hexadecimal number

**active cell:** OFDM cell carrying a constellation point for L1 signalling or a PLP

**auxiliary stream:** sequence of cells carrying data of as yet undefined modulation and coding, which may be used for future extensions or as required by broadcasters or network operators

**BBFRAME:** set of  $K_{\text{bch}}$  bits which form the input to one FEC encoding process (BCH and LDPC encoding)

**bias balancing cells:** special cells inserted into the P2 symbols to reduce the effect of the bias in the L1 signalling

**common PLP:** PLP having one slice per T2-frame, transmitted after the L1 signalling and any bias balancing cells, which may contain data shared by multiple PLPs

**configurable L1-signalling:** L1 signalling consisting of parameters which remain the same for the duration of one super-frame

**data cell:** OFDM cell which is not a pilot or tone reservation cell (may be an unmodulated cell in the Frame Closing Symbol)

**data PLP:** PLP of Type 1 or Type 2

**data symbol:** OFDM symbol in a T2-frame which is not a P1 or P2 symbol

**div:** integer division operator, defined as:

$$x \text{ div } y = \left\lfloor \frac{x}{y} \right\rfloor$$

**dummy cell:** OFDM cell carrying a pseudo-random value used to fill the remaining capacity not used for L1 signalling, PLPs or Auxiliary Streams

**dynamic L1-signalling:** L1 signalling consisting of parameters which may change from one T2-frame to the next

**elementary period:** time period which depends on the system bandwidth and is used to define the other time periods in the T2 system

**FEC Block:** set of  $N_{\text{cells}}$  OFDM cells carrying all the bits of one LDPC FECFRAME

**FECFRAME:** set of  $N_{\text{ldpc}}$  (16 200 or 64 800) bits from one LDPC encoding operation

**FEF part:** part of the super-frame between two T2-frames which contains FEFs

NOTE: A FEF part always starts with a P1 symbol. The remaining contents of the FEF part should be ignored by a DVB-T2 receiver and may contain further P1 symbols.

**FFT size:** nominal FFT size used for a particular mode, equal to the active symbol period  $T_s$  expressed in cycles of the elementary period  $T$

**for  $i=0..xxx-1$ :** the corresponding signalling loop is repeated as many times as there are elements of the loop

NOTE: If there are no elements, the whole loop is omitted.

**frame closing symbol:** OFDM symbol with higher pilot density used at the end of a T2-frame in certain combinations of FFT size, guard interval and scattered pilot pattern

**Im(x):** imaginary part of x

**interleaving frame:** unit over which dynamic capacity allocation for a particular PLP is carried out, made up of an integer, dynamically varying number of FEC blocks and having a fixed relationship to the T2-frames

NOTE: The Interleaving Frame may be mapped directly to one T2-frame or may be mapped to multiple T2-frames. It may contain one or more TI-blocks.

**L1 bias balancing bits:** unused bits within the L1 signalling fields which are nominated to be set so as to reduce the overall bias in the L1 signalling

**L1-post signalling:** signalling carried in the P2 symbol carrying more detailed L1 information about the T2 system and the PLPs

**L1-pre signalling:** signalling carried in the P2 symbols having a fixed size, coding and modulation, including basic information about the T2 system as well as information needed to decode the L1-post signalling

NOTE: L1-pre signalling remains the same for the duration of a super-frame.

**MISO group:** group (1 or 2) to which a particular transmitter in a MISO network belongs, determining the type of processing which is performed to the data cells and the pilots

NOTE: Signals from transmitters in different groups will combine in an optimal manner at the receiver.

**mod:** modulo operator, defined as:

$$x \bmod y = x - y \left\lfloor \frac{x}{y} \right\rfloor$$

**nn<sub>D</sub>:** digits 'nn' should be interpreted as a decimal number

**normal symbol:** OFDM symbol in a T2-frame which is not a P1, P2 or Frame Closing symbol

**OFDM cell:** modulation value for one OFDM carrier during one OFDM symbol, e.g. a single constellation point

**OFDM symbol:** waveform  $T_s$  in duration comprising all the active carriers modulated with their corresponding modulation values and including the guard interval

**P1 signalling:** signalling carried by the P1 symbol and used to identify the basic mode of the DVB-T2 symbol

**P1 symbol:** fixed pilot symbol that carries S1 and S2 signalling fields and is located in the beginning of the frame within each RF-channel

NOTE: The P1 symbol is mainly used for fast initial band scan to detect the T2 signal, its timing, frequency offset, and FFT-size.

**P2 symbol:** pilot symbol located right after P1 with the same FFT-size and guard interval as the data symbols

NOTE: The number of P2 symbols depends on the FFT-size. The P2 symbols are used for fine frequency and timing synchronization as well as for initial channel estimate. P2 symbols carry L1 and L2 signalling information and may also carry data.

**PLP\_ID:** this 8-bit field identifies uniquely a PLP within the T2 system, identified with the T2\_system\_id

NOTE: The same PLP\_ID may occur in one or more frames of the super-frame.

**physical layer pipe:** physical layer TDM channel that is carried by the specified sub-slices

NOTE: A PLP may carry one or multiple services.

**Re(x):** real part of x

**reserved for future use:** not defined by the present document but may be defined in future revisions of the present document

NOTE: Further requirements concerning the use of fields indicated as "reserved for future use" are given in clause 7.1.

**slice:** set of all cells of a PLP which are mapped to a particular T2-frame

NOTE: A slice may be divided into sub-slices.

**sub-slice:** group of cells from a single PLP, which before frequency interleaving, are transmitted on active OFDM cells with consecutive addresses over a single RF channel

**T2-base signal:** a T2 signal using the T2-base profile

**T2 system:** second generation terrestrial broadcast system whose input is one or more TS or GSE streams and whose output is an RF signal

NOTE: The T2 system:

- means an entity where one or more PLPs are carried, in a particular way, within a DVB-T2 signal on one or more frequencies;
- is unique within the T2 network and it is identified with T2\_system\_id. Two T2 systems with the same T2\_system\_id and network\_id have identical physical layer structure and configuration, except for the cell\_id which may differ;
- is transparent to the data that it carries (including transport streams and services).

**T2\_SYSTEM\_ID:** this 16-bit field identifies uniquely the T2 system within the DVB network (identified by NETWORK\_ID)

**T2 Super-frame:** set of T2-frames consisting of a particular number of consecutive T2-frames

NOTE: A super-frame may in addition include FEF parts.

**T2-frame:** fixed physical layer TDM frame that is further divided into variable size sub-slices. T2-frame starts with one P1 and one or multiple P2 symbols

**T2-Lite signal:** a T2 signal using the T2-Lite profile

**T2 profile:** a defined subset of all configurations allowed by the present document.

NOTE: The present document defines a T2-base profile and a T2-Lite profile.

**T2 signal:** a signal consisting of the waveform using a particular profile of the present document (T2-base profile or T2-Lite profile), including any FEF parts.

NOTE: A composite RF signal may be formed comprising two or more T2 signals, where each T2 signal has the others in its FEF parts

**time interleaving block (TI-block):** set of cells within which time interleaving is carried out, corresponding to one use of the time interleaver memory

**type 1 PLP:** PLP having one slice per T2-frame, transmitted before any Type 2 PLPs

**type 2 PLP:** PLP having two or more sub-slices per T2-frame, transmitted after any Type 1 PLPs

## 3.2 Symbols

For the purposes of the present document, the following symbols apply:

$\oplus$	Exclusive OR / modulo-2 addition operation
$\Delta$	Guard interval duration
$\lambda_i$	LDPC codeword bits
$\eta_{\text{MOD}}, \eta_{\text{MOD}}(i)$	number of transmitted bits per constellation symbol (for PLP $i$ )
$I_{\text{TR}}$	Vector containing ones at positions corresponding to reserved carriers and zeros elsewhere
$a_{m,l,p}$	Frequency-Interleaved cell value, cell index $p$ of symbol $l$ of T2-frame $m$
$A_{\text{CP}}$	Amplitude of the continual pilot cells
$A_{\text{P2}}$	Amplitude of the P2 pilot cells
$A_{\text{SP}}$	Amplitude of the scattered pilot cells
$b_{\text{BS},j}$	Bit $j$ of the BB scrambling sequence
$b_{e,do}$	Output bit of index $do$ from substream $e$ from the bit-to-sub-stream demultiplexer
$c(x)$	BCH codeword polynomial
$C/N$	Carrier-to-noise power ratio
$C/N+I$	Carrier-to-(Noise+Interference) ratio
$C_{\text{bal}}(m)$	Value to which bias balancing cells are set for T2-frame $m$
$C'_{\text{bal}}(m)$	Desired value for the bias balancing cells in T2-frame $m$ to approximately balance the bias
$C_{\text{bias}}(m)$	Bias in coded and modulated L1 signalling for T2-frame $m$ before applying the L1-ACE algorithm
$C_{\text{bias\_L1\_ACE}}(m)$	Value of $C_{\text{bias}}(m)$ after being reduced by the correction to be applied by the bias balancing cells
$C'_{\text{bias}}(m)$	Residual bias in the modulated cells of the L1 signalling for T2-frame $m$ after correction by the L1-ACE algorithm
$C_{\text{data}}$	Number of active cells in one normal symbol
$C_{\text{FC}}$	Number of active cells in one frame closing symbol
$C_{\text{im}}(m)$	Imaginary part of $C_{\text{bias}}(m)$
$C_{\text{L1\_ACE\_MAX}}$	Maximum correction applied by L1-ACE algorithm
$c_{m,l,k}$	Cell value for carrier $k$ of symbol $l$ of T2-frame $m$
$C_{\text{P2}}$	Number of active cells in one P2 symbol
$c_{\text{post},m,i}$	Correction applied to cell $i$ of coded and modulated L1-post signalling in T2-frame $m$ by L1-ACE algorithm
$c_{\text{pre},m,i}$	Correction applied to cell $i$ of coded and modulated L1-pre signalling in T2-frame $m$ by L1-ACE algorithm
$C_{\text{re}}(m)$	Real part of $C_{\text{bias}}(m)$
$\text{CSS}_{\text{S1},i}$	Bit $i$ of the S1 modulation sequence
$\text{CSS}_{\text{S2},i}$	Bit $i$ of the S2 modulation sequence
$C_{\text{tot}}$	Number of active cells in one T2-frame
$D_{\text{BC}}$	Number of cells occupied by the bias balancing cells and the associated dummy cells
$D_i$	Number of cells mapped to each T2-frame of the Interleaving Frame for PLP $i$
$D_{i,\text{aux}}$	Number of cells carrying auxiliary stream $i$ in the T2-frame
$D_{i,\text{common}}$	Number of cells mapped to each T2-frame for common PLP $i$
$D_{i,j}$	Number of cells mapped to each T2-frame for PLP $i$ of type $j$
$D_{\text{L1}}$	Number of OFDM cells in each T2-frame carrying L1 signalling
$D_{\text{L1post}}$	Number of OFDM cells in each T2-frame carrying L1-post signalling
$D_{\text{L1pre}}$	Number of OFDM cells in each T2-frame carrying L1-pre signalling

$d_{n,s,r,q}$	Time Interleaver input / Cell interleaver output for cell $q$ of FEC block $r$ of TI-block $s$ of Interleaving Frame $n$
$D_{PLP}$	Number of OFDM cells in each T2-frame available to carry PLPs
$d_{r,q}$	Cell interleaver output for cell $q$ of FEC block $r$
$D_x$	Difference in carrier index between adjacent scattered-pilot-bearing carriers
$D_y$	Difference in symbol number between successive scattered pilots on a given carrier
$e_{m,l,p}$	Cell value for cell index $p$ of symbol $l$ of T2-frame $m$ following MISO processing
$f_c$	Centre frequency of the RF signal
$f_{post_{m,i}}$	Cell $i$ of coded and modulated L1-post signalling for T2-frame $m$
$f'_{post_{m,i}}$	Cell $i$ of L1-post signalling for T2-frame $m$ after modification by the L1-ACE algorithm
$f_{pre_{m,i}}$	Cell $i$ of coded and modulated L1-pre signalling for T2-frame $m$
$f'_{pre_{m,i}}$	Cell $i$ of L1-post signalling for T2-frame $m$ after modification by the L1-ACE algorithm
$f_q$	Constellation point normalized to mean energy of 1
$f_{SH}$	Frequency shift for parts 'B' and 'C' of the P1 signal
$g(x)$	BCH generator polynomial
$g_1(x), g_2(x), \dots, g_{12}(x)$	polynomials to obtain BCH code generator polynomial
$g_q$	OFDM cell value after constellation rotation and cyclic Q delay
$H(p)$	Frequency interleaver permutation function, element $p$
$H_0(p)$	Frequency interleaver permutation function, element $p$ , for even symbols
$H_1(p)$	Frequency interleaver permutation function, element $p$ , for odd symbols
$I_{FEF}$	The value signalled by FEF_INTERVAL
$I_{JUMP}, I_{JUMP}(i)$	Frame interval: difference in frame index between successive T2-frames to which a particular PLP is mapped (for PLP $i$ )
$i_j$	BCH codeword bits which form the LDPC information bits
$j$	$\sqrt{-1}$
$k'$	Carrier index relative to the centre frequency
$k$	OFDM carrier index
$K_{bch}$	number of bits of BCH uncoded Block
$K_{bit}$	1 024 bits
$K_{ext}$	Number of carriers added on each side of the spectrum in extended carrier mode
$K_{L1\_PADDING}$	Length of L1_PADDING field
$K_{ldpc}$	number of bits of LDPC uncoded Block
$K_{max}$	Carrier index of last (highest frequency) active carrier
$K_{min}$	Carrier index of first (lowest frequency) active carrier
$K_{mod}$	Modulo value used to calculate continual pilot locations
$k_{p1}(i)$	Carrier index $k$ for active carrier $i$ of the P1 symbol
$K_{post}$	Length of L1-post signalling field including the padding field
$K_{post\_ex\_pad}$	Number of information bits in L1-post signalling excluding the padding field
$K_{pre}$	Information length of the L1-pre signalling
$K_{sig}$	Number of signalling bits per FEC block for L1-pre- or L1-post signalling
$K_{total}$	Number of OFDM carriers
$l$	Index of OFDM symbol within the T2-frame
$L$	Maximum value of real or imaginary part of the L1-post constellation
$L_{data}$	Number of data symbols per T2-frame including any frame closing symbol but excluding P1 and P2
$L_F$	Number of OFDM symbols per T2-frame excluding P1
$L_{im}(m)$	Correction level for the imaginary part of the L1-post used in the L1-ACE algorithm

$L_{\text{normal}}$	Number of normal symbols in a T2-frame, i.e. not including P1, P2 or any frame closing symbol
$L_{\text{pre}}(m)$	Correction level for the L1-pre used in the L1-ACE algorithm
$L_r(q)$	Cell interleaver permutation function for FEC block $r$ of the TI-block
$L_{\text{re\_post}}(m)$	Correction level for the real part of the L1-post used in the L1-ACE algorithm
$m$	T2-frame number
$M_{\text{aux}}$	Number of auxiliary streams in the T2 system
Mbit	$2^{20}$ bits
Mbit/s	Data rate corresponding to $10^6$ bits per second
$M_{\text{common}}$	Number of common PLPs in the T2 system
$m_i$	BCH message bits
$M_j$	Number of PLPs of type $j$ in the T2 system
$M_{\text{max}}$	Sequence length for the frequency interleaver
$MSS\_DIFF_i$	Bit $i$ of the differentially modulated P1 sequence
$MSS\_SCR_i$	Bit $i$ of the scrambled P1 modulation sequence
$MSS\_SEQ_i$	Bit $i$ of the overall P1 modulation sequence
$M_{TI}$	Maximum number of cells required in the TI memory
$n$	Interleaving Frame index within the super-frame
$N_{\text{bch}}$	number of bits of BCH coded Block
$N_{\text{bch\_parity}}$	Number of BCH parity bits
$N_{\text{bias}}$	Number of bits of bias in the L1-signalling
$N_{\text{biasCellsActive}}$	Number of active bias balancing cells per P2 symbol
$N_{\text{BLOCKS\_IF}}(n), N_{\text{BLOCKS\_IF}}(i,n)$	Number of FEC blocks in Interleaving Frame $n$ (for PLP $i$ )
$N_{\text{BLOCKS\_IF\_MAX}}$	Maximum value of $N_{\text{BLOCKS\_IF}}(n)$
$N_{\text{cells}}, N_{\text{cells}}(i)$	Number of OFDM cells per FEC Block (for PLP $i$ )
$N_{\text{data}}$	Number of data cells in an OFDM symbol (including any unmodulated data cells in the frame closing symbol)
$N_{\text{dummy}}$	Number of dummy cells in the T2-frame
$N_{\text{FEC\_TI}}(n,s)$	Number of FEC blocks in TI-block $s$ of Interleaving Frame $n$
$N_{\text{FEF}}$	Number of FEF parts in one super-frame
$N_{\text{FFT}}$	FFT size
$N_{\text{group}}$	Number of bit-groups for BCH shortening
$N_{\text{im}}(m)$	Number of L1-post cells available for correction by the imaginary part of the L1-ACE algorithm
$N_{L1}$	Total number of bits of L1 signalling
$N_{L1\_mult}$	Number of bits that $N_{\text{post}}$ must be a multiple of
$N_{\text{ldpc}}$	number of bits of LDPC coded Block
$N_{\text{MOD\_per\_Block}}$	Number of modulated cells per FEC block for the L1-post signalling
$N_{\text{MOD\_Total}}$	Total number of modulated cells for the L1-post signalling
$N_{\text{P2}}$	Number of P2 symbols per T2-frame
$N_{\text{pad}}$	Number of BCH bit-groups in which all bits will be padded for L1 signalling
$N_{\text{PN}}$	Length of the frame-level PN sequence
$N_{\text{post}}$	Length of punctured and shortened LDPC codeword for L1-post signalling
$N_{\text{post\_FEC\_Block}}$	Number of FEC blocks for the L1-post signalling
$N_{\text{post\_temp}}$	Intermediate value used in L1 puncturing calculation
$N_{\text{pre}}(m)$	Number of L1-pre cells available for correction by the L1-ACE algorithm
$N_{\text{punc}}$	Number of LDPC parity bits to be punctured
$N_{\text{punc\_groups}}$	Number of parity groups in which all parity bits are punctured for L1 signalling
$N_{\text{punc\_temp}}$	Intermediate value used in L1 puncturing calculation
$N_r$	Number of bits in Frequency Interleaver sequence

$N_{re}(m)$	Total number of L1 cells available for correction by the real part of the L1-ACE algorithm
$N_{re\_post}(m)$	Number of L1-post cells available for correction by the real part of the L1-ACE algorithm
$N_{res}$	Total number of reserved bits of L1 signalling to be used for bias balancing
$N_{RF}$	Number of RF channels used in a TFS system
$N_{subslices}$	Number of sub-slices per T2-frame on each RF channel
$N_{subslices\_total}$	Number of subslices per T2-frame across all RF channels
$N_{substreams}$	Number of substreams produced by the bit-to-sub-stream demultiplexer
$N_{T2}$	Number of T2-frames in a super-frame
$N_{TI}$	Number of TI-blocks in an Interleaving Frame
$p$	Data cell index within the OFDM symbol in the stages prior to insertion of pilots and dummy tone reservation cells
$P(r)$	Cyclic shift value for cell interleaver in FEC block $r$ of the TI-block
$p_1(t)$	Time-domain complex baseband waveform for the P1 signal
$p_{1A}(t)$	Time-domain complex baseband waveform for part 'A' of the P1 signal
$P_I, P_i(i)$	Number of T2-frames to which each Interleaving Frame is mapped (for PLP $i$ )
$p_i$	LDPC parity bits
$pn_l$	Frame level PN sequence value for symbol $l$
$q$	Index of cell within coded and modulated LDPC codeword
$Q_{ldpc}$	Code-rate dependent LDPC constant
$r$	FEC block index within the TI-block
$R_{eff\_16K\_LDPC\_1\_2}$	Effective code rate of 16K LDPC with nominal rate 1/2
$R_{eff\_post}$	Effective code rate of L1-post signalling
$r_i$	BCH remainder bits
$R_i$	Value of element $i$ of the frequency interleaver sequence following bit permutations
$R'_i$	Value of element $i$ of the frequency interleaver sequence prior to bit permutations
$r_{l,k}$	Pilot reference sequence value for carrier $k$ in symbol $l$
$R_{RQD}$	Complex phasor representing constellation rotation angle
$s$	Index of TI-block within the Interleaving Frame
$S_i$	Element $i$ of cell interleaver PRBS sequence
$T$	Elementary time period for the bandwidth in use
$t_c$	Column-twist value for column $c$
$T_F$	Duration of one T2-frame
$T_{FEF}$	Duration of one FEF part
$T_P$	Time interleaving period
$T_{P1}$	Duration of the P1 symbol
$T_{P1A}$	Duration of part 'A' of the P1 signal
$T_{P1B}$	Duration of part 'B' of the P1 signal
$T_{P1C}$	Duration of part 'C' of the P1 signal
$T_S$	Total OFDM symbol duration
$T_{SF}$	Duration of one super-frame
$T_U$	Active OFDM symbol duration
$u_i$	Parity-interleaver output bits
$v_i$	column-twist-interleaver output bits
$w_i$	Bit $i$ of the symbol-level reference PRBS
$\lfloor x \rfloor$	Round towards minus infinity: the most positive integer less than or equal to $x$
$\lceil x \rceil$	Round towards plus infinity: the most negative integer greater than or equal to $x$
$x^*$	Complex conjugate of $x$

$X_j$	The set of bits in group $j$ of BCH information bits for L1 shortening
$x_{m,l,p}$	Complex cell modulation value for cell index $p$ of OFDM symbol $l$ of T2-frame $m$
$y_{i,q}$	Bit $i$ of cell word $q$ from the bit-to-cell-word demultiplexer
$z_q$	Constellation point prior to normalization
$\pi_p$	Permutation operator defining parity bit groups to be punctured for L1 signalling
$\pi_s$	Permutation operator defining bit-groups to be padded for L1 signalling

The symbols  $s, t, i, j, k$  are also used as dummy variables and indices within the context of some clauses or equations.

In general, parameters which have a fixed value for a particular PLP for one processing block (e.g. T2-frame, Interleaving Frame, TI-block as appropriate) are denoted by an upper case letter. Simple lower-case letters are used for indices and dummy variables. The individual bits, cells or words processed by the various stages of the system are denoted by lower case letters with one or more subscripts indicating the relevant indices.

### 3.3 Abbreviations

For the purposes of the present document, the following abbreviations apply:

16-QAM	16-ary Quadrature Amplitude Modulation
256-QAM	256-ary Quadrature Amplitude Modulation
64-QAM	64-ary Quadrature Amplitude Modulation
ACM	Adaptive Coding and Modulation
BB	BaseBand
BCH	Bose-Chaudhuri-Hocquenghem multiple error correction binary block code
BICM	Bit Interleaved Coding and Modulation
CBR	Constant Bit Rate
CCM	Constant Coding and Modulation
CI	Cell Interleaver
CRC	Cyclic Redundancy Check
D	Decimal notation
DAC	Digital to Analogue Conversion
DBPSK	Differential Binary Phase Shift Keying
DFL	Data Field Length
DNP	Deleted Null Packets
DVB	Digital Video Broadcasting project
DVB-T	DVB system for Terrestrial broadcasting

NOTE: Specified in EN 300 744 [i.5].

DVB-T2	DVB-T2 System as specified in the present document
EBU	European Broadcasting Union
EIT	Event Information Table
FEC	Forward Error Correction
FEF	Future Extension Frame
FFT	Fast Fourier Transform
FIFO	First In First Out
GCS	Generic Continuous Stream
GF	Galois Field
GFPS	Generic Fixed-length Packetized Stream
GS	Generic Stream
GSE	Generic Stream Encapsulation
HEM	High Efficiency Mode
HEX	Hexadecimal notation
IF	Intermediate Frequency
IFFT	Inverse Fast Fourier Transform
IS	Interactive Services
ISCR	Input Stream Clock Reference
ISI	Input Stream Identifier



ISSY	Input Stream SYnchronizer
ISSYI	Input Stream SYnchronizer Indicator
LDPC	Low Density Parity Check (codes)
LSB	Least Significant Bit
MIS	Multiple Input Stream
MISO	Multiple Input, Single Output

NOTE: Meaning multiple transmitting antennas but one receiving antenna.

MODCOD	MODulation and CODing
MPEG	Moving Pictures Experts Group
MSB	Most Significant Bit

NOTE: In DVB-T2 the MSB is always transmitted first.

MSS	Modulation Signalling Sequences
NA	Not Applicable
NM	Normal Mode
NPD	Null-Packet Deletion
OFDM	Orthogonal Frequency Division Multiplex
O-UPL	Original User Packet Length
PAPR	Peak to Average Power Ratio
PCR	Programme Clock Reference
PER	(MPEG TS) Packet Error Rate
PID	Packet IDentifier
PLL	Phase Locked Loop
PLP	Physical Layer Pipe
PRBS	Pseudo Random Binary Sequence
QEF	Quasi Error Free
QPSK	Quaternary Phase Shift Keying
RF	Radio Frequency
SDT	Service Description Table
SIS	Single Input Stream
SISO	Single Input Single Output (meaning one transmitting and one receiving antenna)
SoAC	Sum of AutoCorrelation
TDM	Time Division Multiplex
TF	Time/Frequency
TFS	Time-Frequency Slicing
TS	Transport Stream
TSPS	Transport Stream Partial Stream
TSPSC	Transport Stream Partial Stream Common
TTO	Time To Output
TV	TeleVision
UP	User Packet
UPL	User Packet Length
VCM	Variable Coding and Modulation

---

## 4 DVB-T2 System architecture

### 4.1 System overview

The generic T2 system model is represented in figure 1. The system input(s) may be one or more MPEG-2 Transport Stream(s) [i.1] and/or one or more Generic Stream(s) [i.2]. The Input Pre-Processor, which is not part of the T2 system, may include a Service splitter or de-multiplexer for Transport Streams (TS) for separating the services into the T2 system inputs, which are one or more logical data streams. These are then carried in individual Physical Layer Pipes (PLPs).

The system output is typically a single signal to be transmitted on a single RF channel. Optionally, the system can generate a second set of output signals, to be conveyed to a second set of antennas in what is called MISO transmission mode.

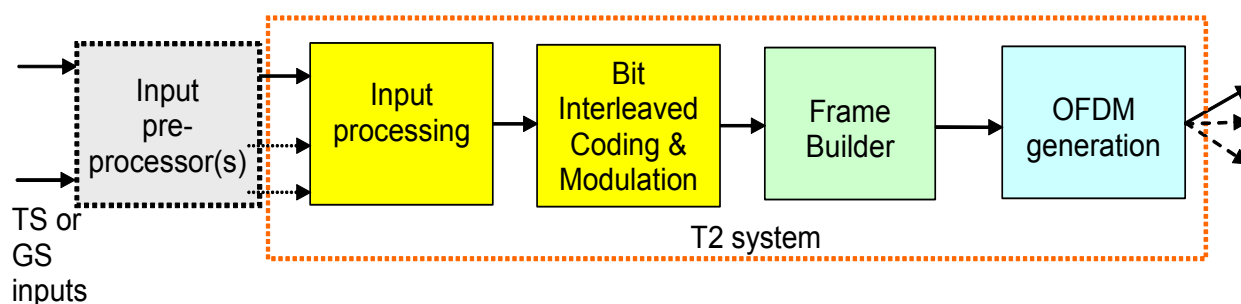
Versions 1.1.1 and 1.2.1 of this specification defined a single profile which incorporates time-slicing but not time-frequency-slicing (TFS). Features which would allow a possible future implementation of TFS (for receivers with two tuners/front-ends) can be found in annex E. It is not intended that a receiver with a single tuner should support TFS.

The present document (version 1.3.1 of this specification) adds a T2-Lite profile. This profile is intended to allow simpler receiver implementations for very low capacity applications such as mobile broadcasting, although it may also be received by conventional stationary receivers. The details of this T2-Lite profile are described in annex I. Version 1.3.1 also introduces a name, which is 'T2-base profile' for the previous single profile. The T2-base profile consists of all allowed configurations according to the present document except for a small subset of configurations that are specific to the T2-Lite profile as defined in annex I. A configuration meeting all of the requirements of annex I is a T2-Lite profile configuration.

A T2 signal consists of the waveform carrying a particular profile (e.g. T2-base profile or T2-Lite profile), including any FEF parts. Different profiles may be combined in the same RF signal by transmitting a T2 signal using one profile within FEF parts of another T2 signal using another profile.

When a T2 signal is transmitted using a particular profile, the FEF parts of this signal shall not carry T2 signals using this same profile.

NOTE: Other profiles may be added in the future.



**Figure 1: High level T2 block diagram**

The input data streams shall be subject to the constraint that, over the duration of one physical-layer frame (T2-frame), the total input data capacity (in terms of cell throughput, following null-packet deletion, if applicable, and after coding and modulation), shall not exceed the T2 available capacity (in terms of data cells, constant in time) of the T2-frame for the current frame parameters. Typically, this will be achieved by arranging that PLPs within a group of PLPs will always use same modulation and coding (MODCOD), and interleaving depth, and that one or more groups of PLPs with the same MODCOD and interleaving depth originate from a single, constant bit-rate, statistically-multiplexed source. Each group of PLPs may contain one common PLP, but a group of PLPs need not contain a common PLP. When the DVB-T2 signal carries a single PLP there is no common PLP. It is assumed that the receiver will always be able to receive one data PLP and its associated common PLP, if any.

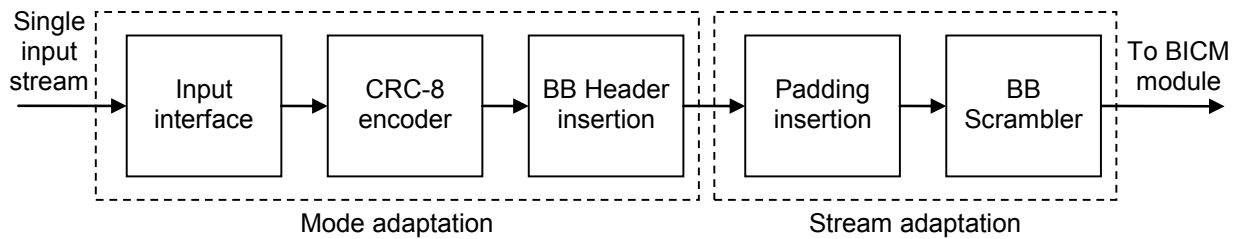
More generally, the group of statistically multiplexed services can use variable coding and modulation (VCM) for different services, provided they generate a constant total output capacity (i.e. in terms of cell rate including FEC and modulation).

When multiple input MPEG-2 TSs are transmitted via a group of PLPs, splitting of input TSs into TSPS streams (carried via the data PLPs) and a TSPSC stream (carried via the associated common PLP), as described in annex D, shall be performed immediately before the Input processing block shown in figure 1. This processing shall be considered an integral part of an extended DVB-T2 system.

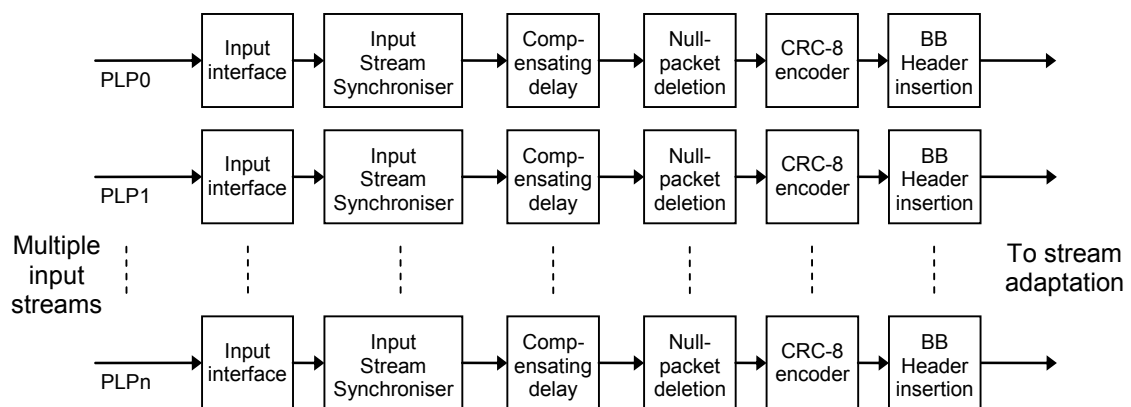
The maximum input rate for any TS, including null packets, shall be 72 Mbit/s. The maximum achievable throughput rate, after deletion of null packets when applicable, is more than 50 Mbit/s (in an 8 MHz channel). These rates are modified for the T2-Lite profile (see annex I).

## 4.2 System architecture

The T2 system block diagram is shown in figure 2, which is split into several parts. Figure 2(a) shows the input processing for input mode 'A' (single PLP), and figure 2(b) and figure 2(c) show the case of input mode 'B' (multiple PLPs). Figure 2(d) shows the BICM module and figure 2(e) shows the frame builder module. Figure 2(f) shows the OFDM generation module.



**Figure 2: System block diagram:**  
**(a) Input processing module for input mode 'A' (single PLP)**



**Figure 2(b): Mode adaptation for input mode 'B' (multiple PLP)**

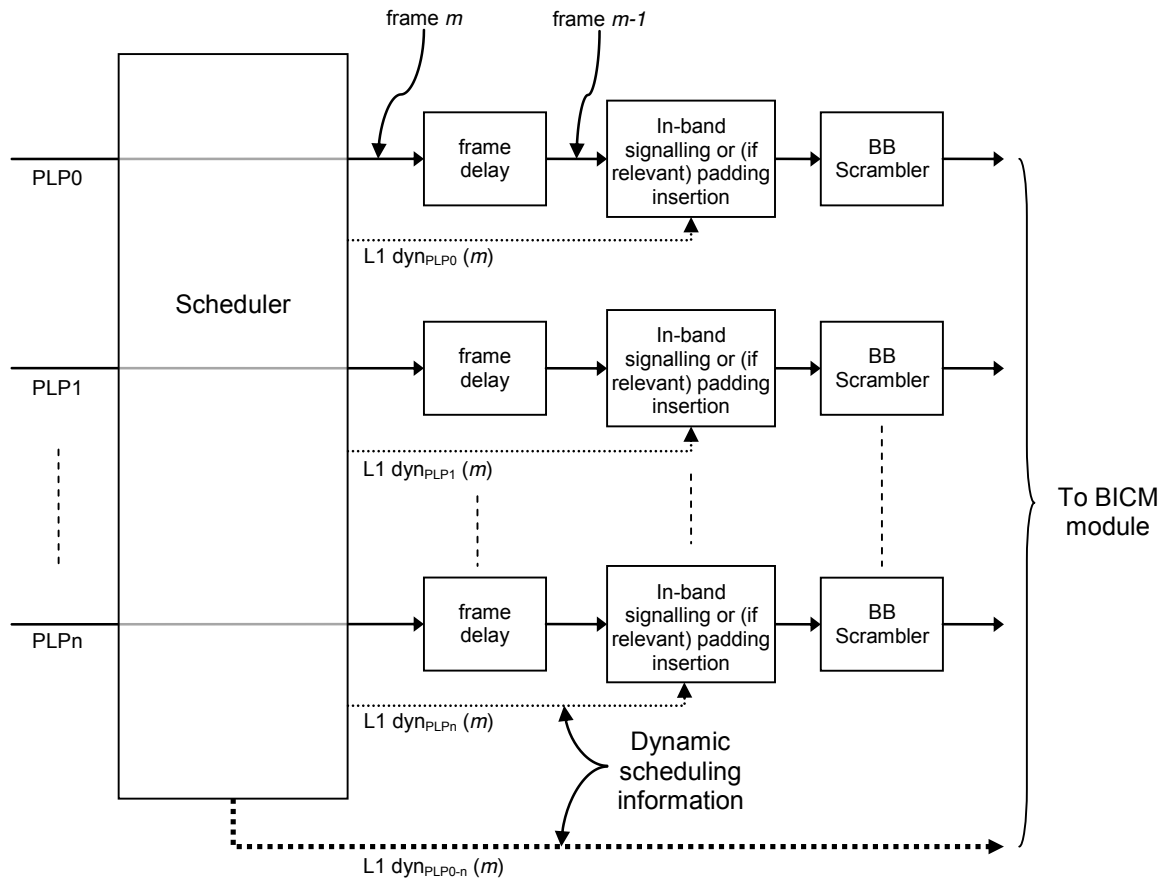


Figure 2(c): Stream adaptation for input mode 'B' (multiple PLP)

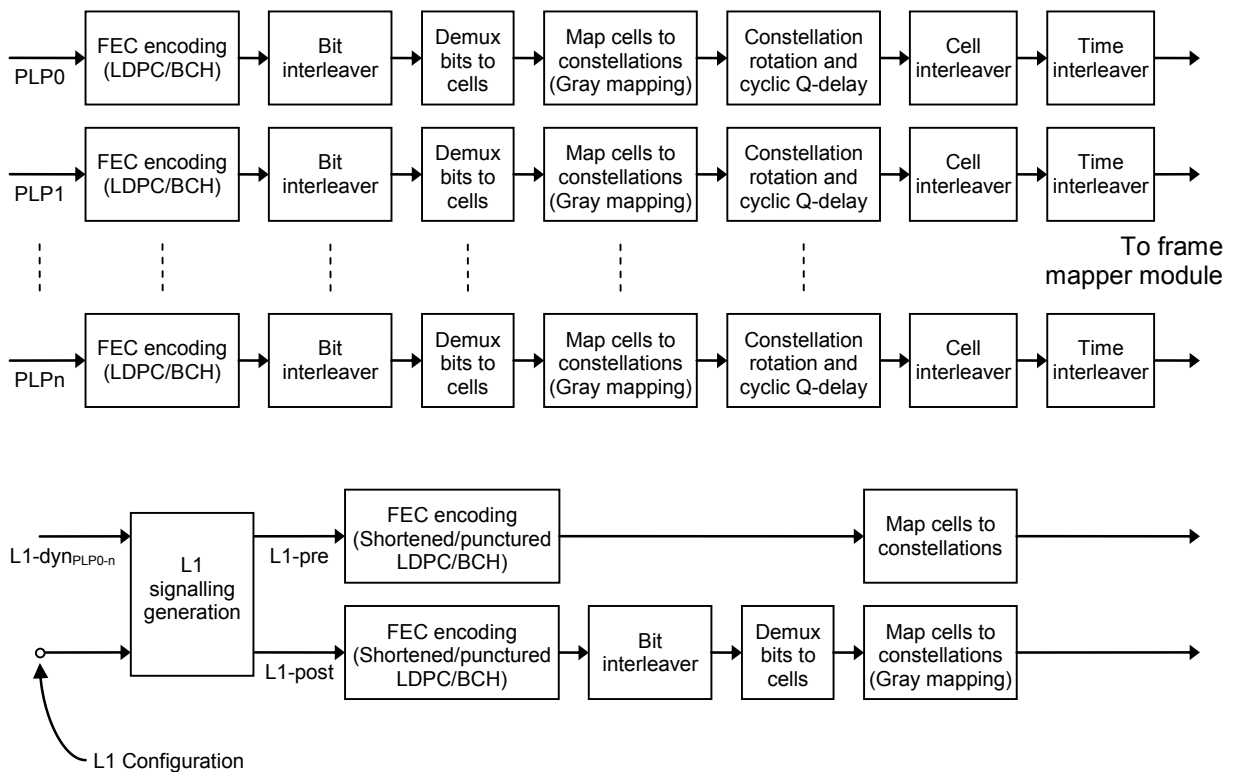
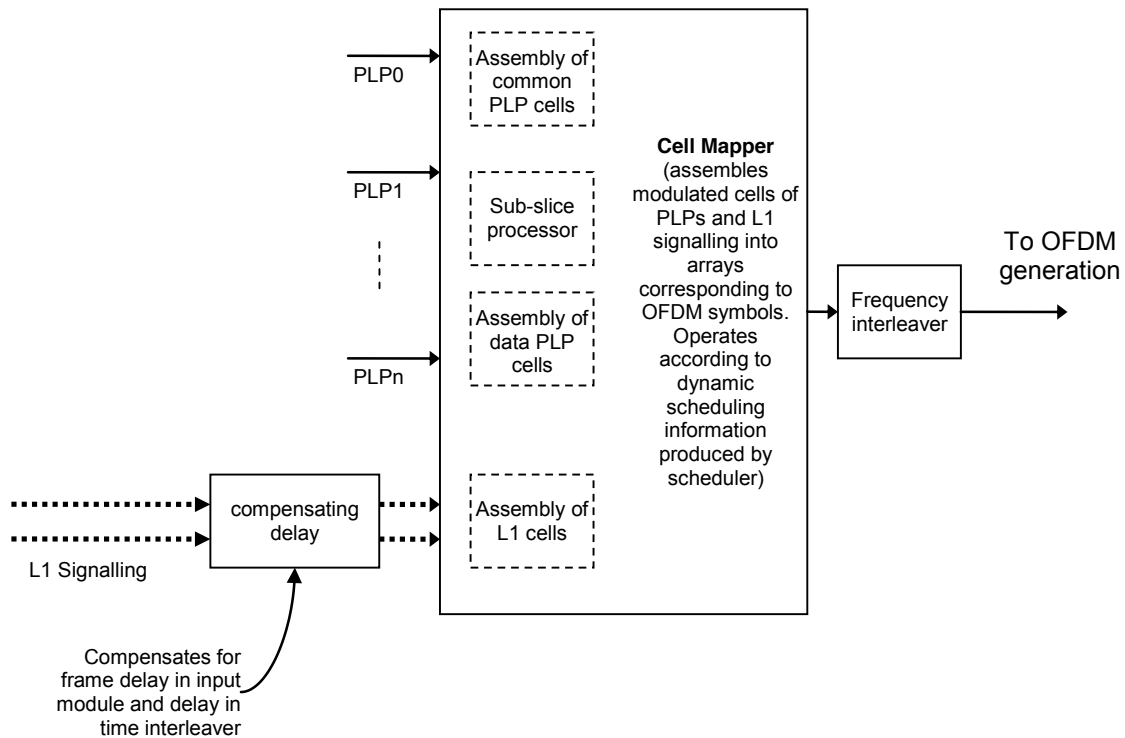
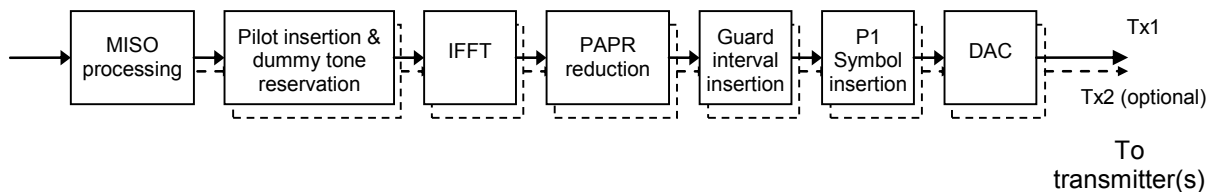


Figure 2(d): Bit Interleaved Coding and Modulation (BICM)



**Figure 2(e): Frame builder**



**Figure 2(f): OFDM generation**

NOTE: The term "modulator" is used throughout the present document to refer to equipment carrying out the complete modulation process starting from input streams and finishing with the signal ready to be upconverted and transmitted, and including the input interface, formation of BBFRAMES, etc. (i.e. mode adaptation). However other documents may sometimes refer to the mode adaptation being carried out within a T2-gateway, and in this context the term "modulator" refers to equipment accepting BBFRAMES at its input, and applying processing from the stream adaptation module onwards.

Care should be taken to ensure these two usages are not confused.

### 4.3 Target performance

If the received signal is above the  $C/N+I$  threshold, the Forward Error Correction (FEC) technique adopted in the System is designed to provide a "Quasi Error Free" (QEF) quality target. The definition of QEF adopted for DVB-T2 is "less than one uncorrected error-event per transmission hour at the level of a 5 Mbit/s single TV service decoder", approximately corresponding to a Transport Stream Packet Error Ratio  $PER < 10^{-7}$  before the de-multiplexer.

## 5 Input processing

### 5.1 Mode adaptation

The input to the T2 system shall consist of one or more logical data streams. One logical data stream is carried by one Physical Layer Pipe (PLP). The mode adaptation modules, which operate separately on the contents of each PLP, slice the input data stream into data fields which, after stream adaptation, will form baseband frames (BBFRAMEs). The mode adaptation module comprises the input interface, followed by three optional sub-systems (the input stream synchronizer, null packet deletion and the CRC-8 encoder) and then finishes by slicing the incoming data stream into data fields and inserting the baseband header (BBHEADER) at the start of each data field. Each of these sub-systems is described in the following clauses.

Each input PLP may have one of the formats specified in clause 5.1.1. The mode adaptation module can process input data in one of two modes, normal mode (NM) or high efficiency mode (HEM), which are described in clauses 5.1.7 and 5.1.8 respectively. NM is in line with the Mode Adaptation in [i.3], whereas in HEM, further stream specific optimizations may be performed to reduce signalling overhead. The BBHEADER (see clause 5.1.7) signals the input stream type and the processing mode.

#### 5.1.1 Input Formats

The Input Pre-processor/Service Splitter (see figure 1) shall supply to the Mode Adaptation Module(s) a single or multiple streams (one for each Mode Adaptation Module). In the case of a TS, the packet rate will be a constant value, although only a proportion of the packets may correspond to service data and the remainder may be null-packets.

Each input stream (PLP) of the T2 system shall be associated with a modulation and FEC protection mode which is statically configurable.

Each input PLP may take one of the following formats:

- Transport Stream (TS) [i.1].
- Generic Encapsulated Stream (GSE) [i.2].
- Generic Continuous Stream (GCS) (a variable length packet stream where the modulator is not aware of the packet boundaries).
- Generic Fixed-length Packetized Stream (GFPS); this form is retained for compatibility with DVB-S2 [i.3], but it is expected that GSE would now be used instead.

A Transport Stream shall be characterized by User Packets (UP) of fixed length  $O\text{-UPL} = 188 \times 8$  bits (one MPEG packet), the first byte being a Sync-byte ( $47_{\text{HEX}}$ ). It shall be signalled in the BBHEADER TS/GS field, see clause 5.1.7.

NOTE: The maximum achievable throughput rate, after deletion of null packets when applicable, is approximately 50,3 Mbit/s (in an 8 MHz channel).

A GSE stream shall be characterized by variable length packets or constant length packets, as signalled within GSE packet headers, and shall be signalled in the BBHEADER by TS/GS field, see clause 5.1.7.

A GCS shall be characterized by a continuous bit-stream and shall be signalled in the BBHEADER by TS/GS field and  $UPL = 0_D$ , see clause 5.1.7. A variable length packet stream where the modulator is not aware of the packet boundaries, or a constant length packet stream exceeding 64 kbit, shall be treated as a GCS, and shall be signalled in the BBHEADER by TS/GS field as a GCS and  $UPL = 0_D$ , see clause 5.1.7.

A GFPS shall be a stream of constant-length User Packets (UP), with length  $O\text{-UPL}$  bits (maximum  $O\text{-UPL}$  value 64 K), and shall be signalled in the base-band header TS/GS field, see clause 5.1.7.  $O\text{-UPL}$  is the Original User Packet Length.  $UPL$  is the transmitted User Packet Length, as signalled in the BBHEADER.

## 5.1.2 Input Interface

The input interface subsystem shall map the input into internal logical-bit format. The first received bit will be indicated as the Most Significant Bit (MSB). Input interfacing is applied separately for each single physical layer pipe (PLP), see figure 2.

The Input Interface shall read a data field, composed of DFL bits (Data Field Length), where:

$$0 \leq \text{DFL} \leq (K_{\text{bch}} - 80)$$

where  $K_{\text{bch}}$  is the number of bits protected by the BCH and LDPC codes (see clause 6.1).

The maximum value of DFL depends on the chosen LDPC code, carrying a protected payload of  $K_{\text{bch}}$  bits. The 10-byte (80 bits) BBHEADER is appended to the front of the data field, and is also protected by the BCH and LDPC codes.

The Input Interface shall either allocate a number of input bits equal to the available data field capacity, thus breaking UPs in subsequent data fields (this operation being called "fragmentation"), or shall allocate an integer number of UPs within the data field (no fragmentation). The available data field capacity is equal to  $K_{\text{bch}} - 80$  when in-band signalling is not used (see clause 5.2.3), but less when in-band signalling is used. When the value of  $\text{DFL} < K_{\text{bch}} - 80$ , a padding field shall be inserted by the stream adapter (see clause 5.2) to complete the LDPC / BCH code block capacity. A padding field, if applicable, shall also be allocated in the first BBFRAME of a T2-Frame, to transmit in-band signalling (whether fragmentation is used or not).

## 5.1.3 Input Stream Synchronization (Optional)

Data processing in the DVB-T2 modulator may produce variable transmission delay on the user information. The Input Stream Synchronizer subsystem shall provide suitable means to guarantee Constant Bit Rate (CBR) and constant end-to-end transmission delay for any input data format. The use of the Input Stream Synchronizer subsystem is optional for PLPs carrying GSE, GCS or GFPS streams. In the case of PLPs carrying transport streams (TS), it shall always be used, except that its use is optional when the following five conditions all apply (see clauses 5.1.7, 7.2.1, 7.2.3.1 and 7.2.3.2 for further details of the relevant signalling fields):

- 1) NUM\_PLP=1; and
- 2)  $\text{DFL} = K_{\text{BCH}} - 80$  in every BBFRAME; and
- 3)  $\text{PLP\_NUM\_BLOCKS} = \text{PLP\_NUM\_BLOCKS\_MAX}$  in every interleaving frame; and
- 4) Null Packet Deletion is not used (i.e.  $\text{NPD} = 0$ ); and
- 5) FEFs are not used (i.e.  $\text{S2} = \text{'XXX0'}$ ).

Input stream synchronization shall follow the specification given in annex C, which is similar to [i.3]. Examples of receiver implementation are given in annex J. This process will also allow synchronization of multiple input streams travelling in independent PLPs, since the reference clock and the counter of the input stream synchronizers shall be the same.

The ISSY field (Input Stream Synchronization, 2 bytes or 3 bytes) carries the value of a counter clocked at the modulator clock rate ( $1/T$  where  $T$  is defined in clause 9.5) and can be used by the receiver to regenerate the correct timing of the regenerated output stream. The ISSY field carriage shall depend on the input stream format and on the Mode, as defined in clauses 5.1.7 and 5.1.8 and figures 4 to 8. In Normal Mode the ISSY Field is appended to UPs for packetized streams. In High Efficiency Mode a single ISSY field is transmitted per BBFRAME in the BBHEADER, taking advantage that UPs of a BBFRAME travel together, and therefore experience the same delay/jitter.

When the ISSY mechanism is not being used, the corresponding fields of the BBHEADER, if any, shall be set to '0'.

A full description of the format of the ISSY field is given in annex C.

### 5.1.4 Compensating Delay for Transport Streams

The interleaving parameters  $P_1$  and  $N_{TI}$  (see clause 6.5), and the frame interval  $I_{JUMP}$  (see clause 8.2) may be different for the data PLPs in a group and the corresponding common PLP. In order to allow the Transport Stream recombining mechanism described in annex D without requiring additional memory in the receiver, the input Transport Streams shall be delayed in the modulator following the insertion of Input Stream Synchronization information. The delay (and the indicated value of TTO - see annex C) shall be such that, for a receiver implementing the buffer strategy defined in clause C.1.1, the partial transport streams at the output of the de-jitter buffers for the data and common PLPs would be essentially co-timed, i.e. packets with corresponding ISCR values on the two streams would be output within 1ms of one another.

### 5.1.5 Null Packet Deletion (optional, for TS only, NM and HEM)

Transport Stream rules require that bit rates at the output of the transmitter's multiplexer and at the input of the receiver's demultiplexer are constant in time and the end-to-end delay is also constant. For some Transport-Stream input signals, a large percentage of null-packets may be present in order to accommodate variable bit-rate services in a constant bit-rate TS. In this case, in order to avoid unnecessary transmission overhead, TS null-packets shall be identified (PID = 8191<sub>D</sub>) and removed. The process is carried-out in a way that the removed null-packets can be re-inserted in the receiver in the exact place where they were originally, thus guaranteeing constant bit-rate and avoiding the need for time-stamp (PCR) updating.

When Null Packet Deletion is used, Useful Packets (i.e. TS packets with PID  $\neq$  8191<sub>D</sub>), including the optional ISSY appended field, shall be transmitted while null-packets (i.e. TS packets with PID = 8191<sub>D</sub>), including the optional ISSY appended field, may be removed. See figure 3.

After transmission of a UP, a counter called DNP (Deleted Null-Packets, 1 byte) shall be first reset and then incremented at each deleted null-packet. When DNP reaches the maximum allowed value  $DNP = 255_{D}$ , then if the following packet is again a null-packet this null-packet is kept as a useful packet and transmitted.

Insertion of the DNP field (1 byte) shall be after each transmitted UP according to clause 5.1.8 and figures 5 and 6.

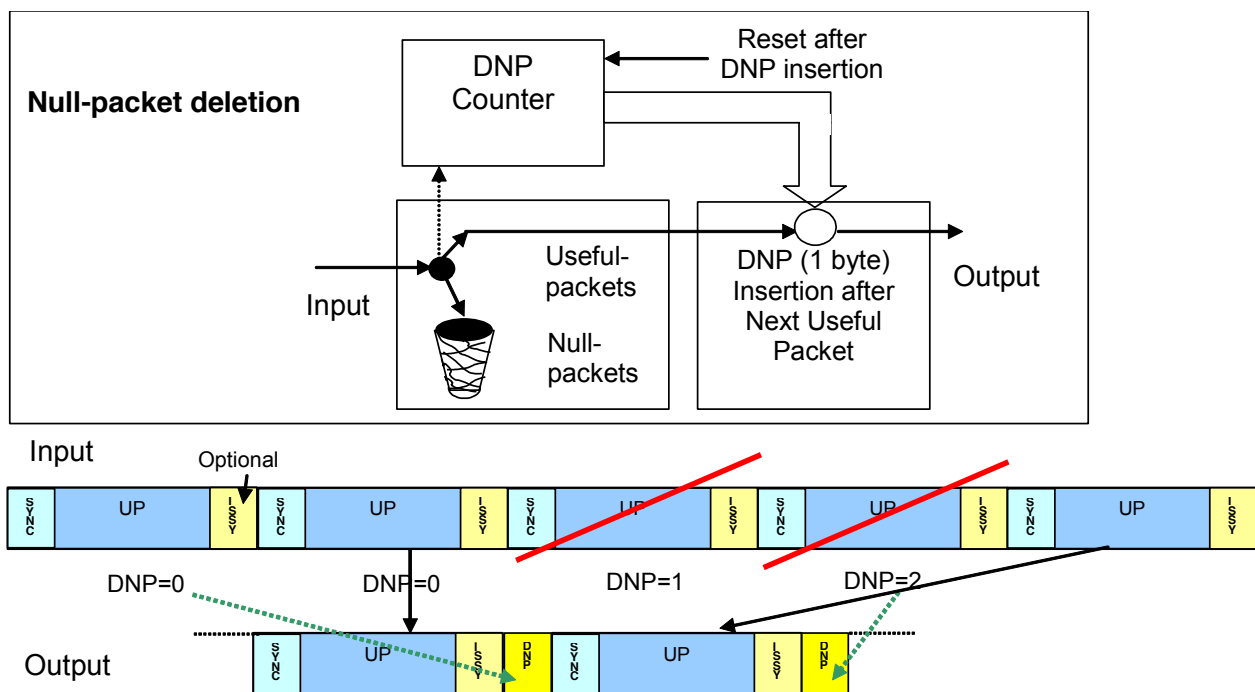


Figure 3: Null packet deletion scheme

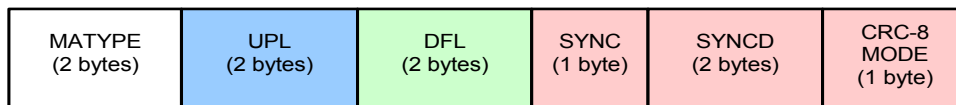


### 5.1.6 CRC-8 encoding (for GFPS and TS, NM only)

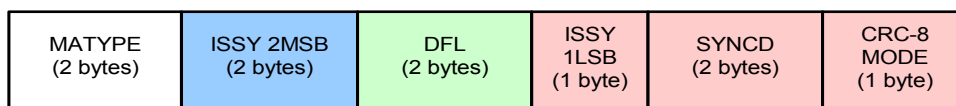
CRC-8 is applied for error detection at UP level (Normal Mode and packetized streams only). When applicable (see clause 5.1.8), the UPL-8 bits of the UP (after sync-byte removal, when applicable) shall be processed by the systematic 8-bit CRC-8 encoder defined in annex F. The computed CRC-8 shall be appended after the UP according to clause 5.1.8 and figure 5.

### 5.1.7 Baseband Header (BBHEADER) insertion

A fixed length BBHEADER of 10 bytes shall be inserted in front of the baseband data field in order to describe the format of the data field. The BBHEADER shall take one of two forms as shown in figure 4(a) for normal mode (NM) and in figure 4(b) for high efficiency mode (HEM). The current mode (NM or HEM) may be detected by the MODE field (EXORed with the CRC-8 field).



**Figure 4(a): BBHEADER format (NM)**



**Figure 4(b): BBHEADER format (HEM)**

The use of the bits of the MATYPE field is described below. The use of the remaining fields of the BBHEADER is described in table 2.

**MATYPE (2 bytes):** describes the input stream format and the type of Mode Adaptation as explained in table 1.

**First byte (MATYPE-1):**

- TS/GS field (2 bits), Input Stream Format: Generic Packetized Stream (GFPS); Transport Stream; Generic Continuous Stream (GCS); Generic Encapsulated Stream (GSE).
- SIS/MIS field (1 bit): Single or Multiple Input Streams (referred to the global signal, not to each PLP).
- CCM/ACM field (1 bit): Constant Coding and Modulation or Variable Coding and Modulation.

NOTE 1: The term ACM is retained for compatibility with DVB-S2 [i.3]. CCM means that all PLPs use the same coding and modulation, whereas ACM means that not all PLPs use the same coding and modulation. In each PLP, the modulation and coding will be constant in time (although it may be statically reconfigured).

- ISSYI (1 bit), (Input Stream Synchronization Indicator): If ISSYI = 1 = active, the ISSY field shall be computed (see annex C) and inserted according to clause 5.1.8.
- NPD (1 bit): Null-packet deletion active/not active. If NPD active, then DNP shall be computed and appended after UPs.
- EXT (2 bits), media specific (for T2, EXT=0: reserved for future use).

**Table 1: MATYPE-1 field mapping**

TS/GS (2 bits)	SIS/MIS (1 bit)	CCM/ACM (1 bit)	ISSYI (1 bit)	NPD (1 bit)	EXT (2 bits)
00 = GFPS 11 = TS 01 = GCS 10 = GSE	1 = single 0 = multiple	1 = CCM 0 = ACM	1 = active 0 = not-active	1 = active 0 = not-active	Reserved for future use (see note 1)
NOTE 1: For T2, EXT=reserved for future use and for S2, EXT=RO =transmission roll-off.					
NOTE 2: For compatibility with DVB-S2 [i.3], when GSE is used with normal mode, it shall be treated as a Continuous Stream and indicated by TS/GS = 01.					

**Second byte (MATYPE-2):**

- If SIS/MIS = Multiple Input Stream, then second byte = Input Stream Identifier (ISI); else second byte = '0' (reserved for future use).

NOTE 2: The term ISI is retained here for compatibility with DVB-S2 [i.3], but has the same meaning as the term PLP\_ID which is used throughout the present document.

**Table 2: Description of the fields of the BBHEADER**

Field	Size (Bytes)	Description
MATYPE	2	As described above
UPL	2	User Packet Length in bits, in the range [0,65535]
DFL	2	Data Field Length in bits, in the range [0,53760]
SYNC	1	A copy of the User Packet Sync-byte. In the case of GCS, SYNC=0x00-0xB8 is reserved for transport layer protocol signalling and shall be set according to [1], SYNC=0xB9-0xFF user private
SYNCD	2	The distance in bits from the beginning of the DATA FIELD to the beginning of the first transmitted UP which starts in the data field. SYNCD=0 <sub>D</sub> means that the first UP is aligned to the beginning of the Data Field. SYNCD = 65535 <sub>D</sub> means that no UP starts in the DATA FIELD; for GCS, SYNCD is reserved for future use and shall be set to 0 <sub>D</sub> unless otherwise defined.
CRC-8 MODE	1	The XOR of the <b>CRC-8</b> (1-byte) field with the <b>MODE</b> field (1-byte). <b>CRC-8</b> is the error detection code applied to the first 9 bytes of the BBHEADER (see annex F). <b>MODE</b> (8 bits) shall be: <ul style="list-style-type: none"> <li>• 0<sub>D</sub> Normal Mode.</li> <li>• 1<sub>D</sub> High Efficiency Mode.</li> <li>• Other values: reserved for future use.</li> </ul>

## 5.1.8 Mode adaptation sub-system output stream formats

This clause describes the Mode Adaptation processing and fragmentation for the various Modes and Input Stream formats, as well as illustrating the output stream format.

**Normal Mode, GFPS and TS**

See clause 5.1.7 for BBHEADER signalling.

For Transport Stream, O-UPL=188x8 bits, and the first byte shall be a Sync-byte (47<sub>HEX</sub>). UPL (the transmitted user packet length) shall initially be set equal to O-UPL.

The Mode Adaptation unit shall perform the following sequence of operations (see figure 5):

- Optional input stream synchronization (see clause 5.1.3); UPL increased by 16<sub>D</sub> or 24<sub>D</sub> bits according to ISSY field length; ISSY field appended after each UP. For TS, either the short or long format of ISSY may be used; for GFPS, only the short format may be used.
- If a sync-byte is the first byte of the UP, it shall be removed, and stored in the SYNC field of the BBHEADER, and UPL shall be decreased by 8<sub>D</sub>. Otherwise SYNC in the BBHEADER shall be set to 0 and UPL shall remain unmodified.

- For TS only, optional null-packet deletion (see clause 5.1.5); DNP computation and storage after the next transmitted UP; UPL increased by  $8_D$ .
- CRC-8 computation at UP level (see clause 5.1.6); CRC-8 storage after the UP; UPL increased by  $8_D$ .
- SYNC D computation (pointing at the first bit of the first transmitted UP which starts in the Data Field) and storage in BBHEADER. The bits of the transmitted UP start with the CRC-8 of the previous UP, if used, followed by the original UP itself, and finish with the ISSY and DNP fields, if used. Hence SYNC D points to the first bit of the CRC-8 of the previous UP.
- For GFPS: UPL storage in BBHEADER.

NOTE 1: O-UPL in the modulator may be derived by static setting (GFPS only) or un-specified automatic signalling.

NOTE 2: Normal Mode is compatible with DVB-S2 BBFRAME Mode Adaptation [i.3]. SYNC D=0 means that the UP is aligned to the start of the Data Field and when present, the CRC-8 (belonging to the last UP of the previous BBFRAME) will be replaced in the receiver by the SYNC byte or discarded.

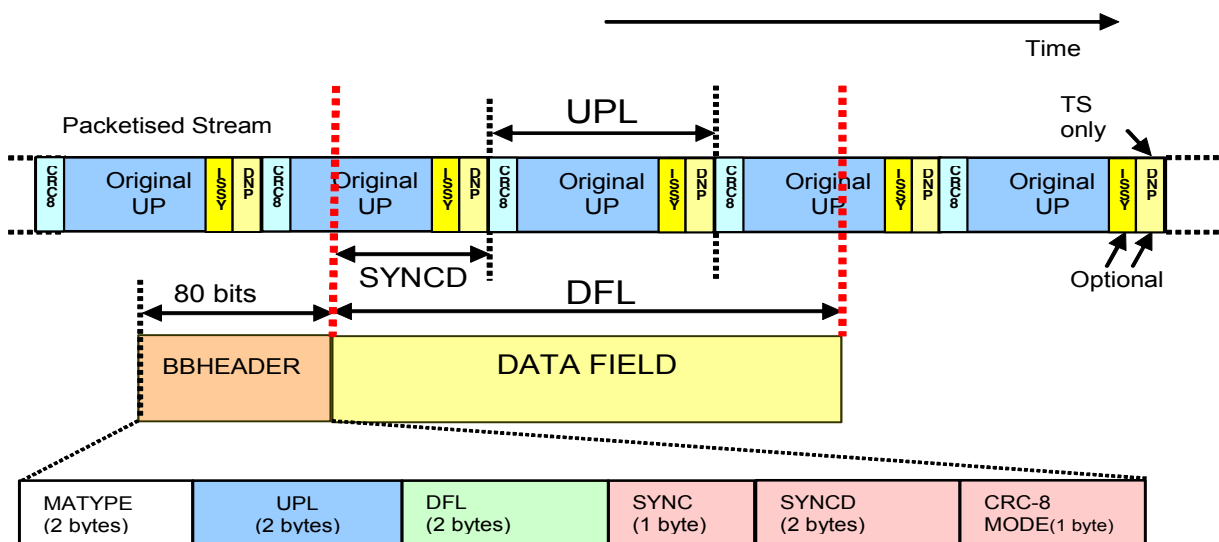
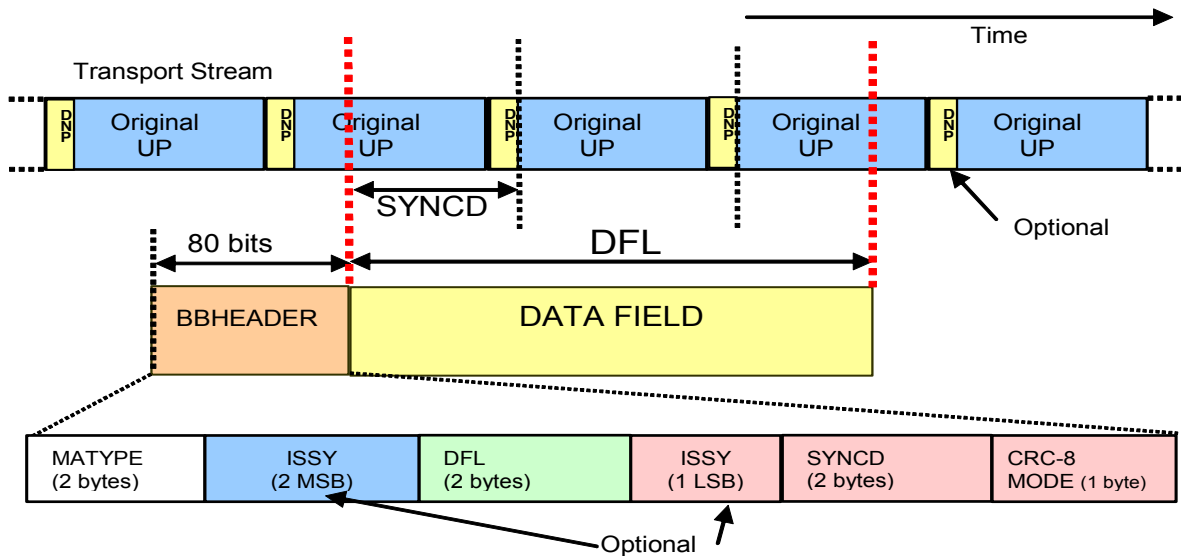


Figure 5: Stream format at the output of the MODE ADAPTER, Normal Mode, GFPS and TS

### High Efficiency Mode, Transport Streams

For **Transport Streams**, the receiver knows a-priori the sync-byte configuration and O-UPL=188x8 bits, therefore UPL and SYNC fields in the BBHEADER shall be re-used to transmit the ISSY field. The Mode Adaptation unit shall perform the following sequence of operations (see figure 6):

- Optional input stream synchronization (see clause 5.1.3) relevant to the first complete transmitted UP of the data field; ISSY field inserted in the UPL and SYNC fields of the BBHEADER.
- Sync-byte removed, but not stored in the SYNC field of the BBHEADER.
- Optional null-packet deletion (see clause 5.1.5); DNP computation and storage after the next transmitted UP.
- CRC-8 at UP level shall not be computed nor inserted.
- SYNC D computation (pointing at the first bit of the first transmitted UP which starts in the Data Field) and storage in BBHEADER. The bits of the transmitted UP start with the original UP itself after removal of the sync-byte, and finish with the DNP field, if used. Hence SYNC D points to the first bit of the original UP following the sync-byte.
- UPL not computed nor transmitted in the BBHEADER.



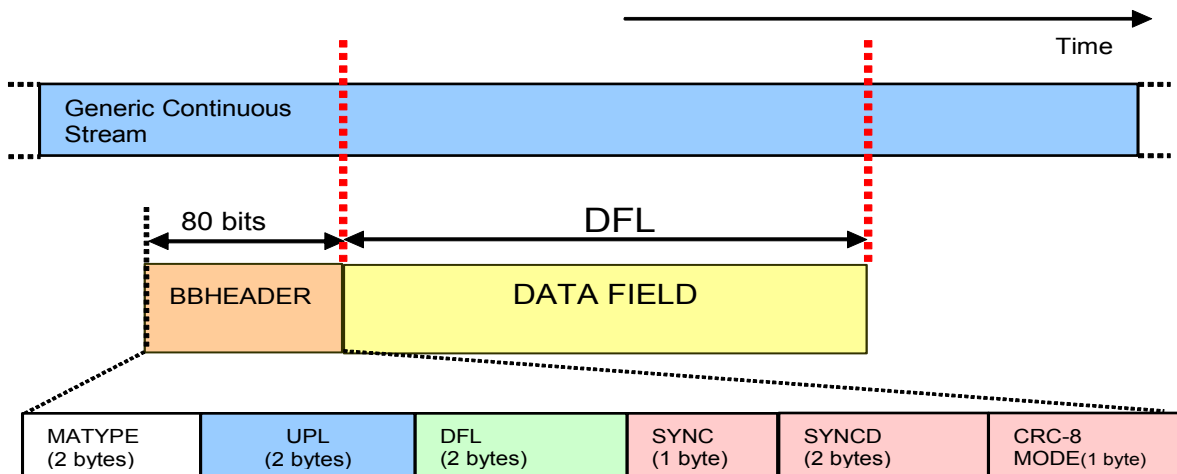
**Figure 6: Stream format at the output of the MODE ADAPTER, High Efficiency Mode for TS, (no CRC-8 computed for UPs, optional single ISSY inserted in the BBHEADER, UPL not transmitted)**

#### Normal Mode, GCS and GSE

See clause 5.1.7 for BBHEADER signalling. For GCS the input stream shall have no structure, or the structure shall not be known by the modulator. For GSE the first GSE packet shall always be aligned to the data field (no GSE fragmentation allowed).

For both GCS and GSE the Mode Adaptation unit shall perform the following sequence of operations (see figure 7):

- Set  $UPL=0_D$ ; set  $SYNC=0x00-0xB8$  is reserved for transport layer protocol signalling and should be set according to [1],  $SYNC=0xB9-0xFF$  user private;  $SYNCD$  is reserved for future use and shall be set to  $0_D$  when not otherwise defined.
- Null packed deletion (see clause 5.1.5) and CRC-8 computation for Data Field (see clause 5.1.6) shall not be performed.



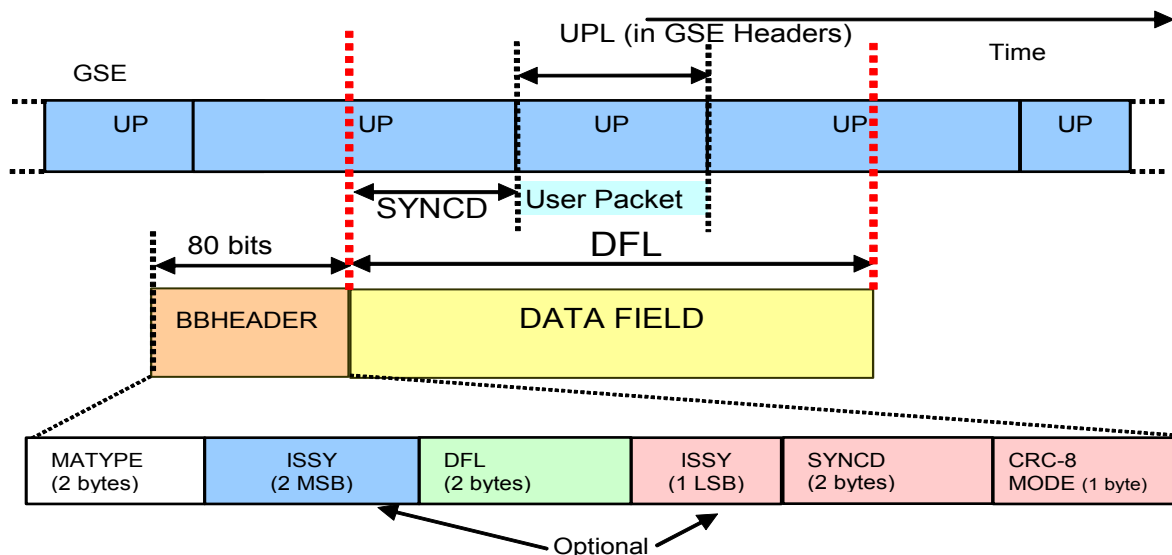
**Figure 7: Stream format at the output of the MODE ADAPTER, Normal Mode (GSE & GCS)**

### High Efficiency Mode, GSE

GSE variable-length or constant length UPs may be transmitted in HEM. If GSE packet fragmentation is used, SYNCND shall be computed. If the GSE packets are not fragmented, the first packet shall be aligned to the Data Field and thus SYNCND shall always be set to 0<sub>D</sub>. The receiver may derive the length of the UPs from the packet header [i.2], therefore UPL transmission in BBHEADER is not performed. As per TS, the optional ISSY field is transmitted in the BBHEADER.

The Mode Adaptation unit shall perform the following sequence of operations (see figure 8):

- Optional input stream synchronization (see clause 5.1.3) relevant to the first transmitted UP which starts in the data field; ISSY field inserted in the UPL and SYNC fields of the BBHEADER.
- Null-packet Deletion and CRC-8 at UP level shall not be computed nor inserted.
- SYNCND computation (pointing at the first bit of the first transmitted UP which starts in the Data Field) and storage in BBHEADER. The transmitted UP corresponds exactly to the original UP itself. Hence SYNCND points to the first bit of the original UP.
- UPL not computed nor transmitted.



**Figure 8: Stream format at the output of the MODE ADAPTER, High Efficiency Mode for GSE, (no CRC-8 computed for UPs, optional single ISSY inserted in the BBHEADER, UPL not transmitted)**

### High Efficiency Mode, GFPS and GCS

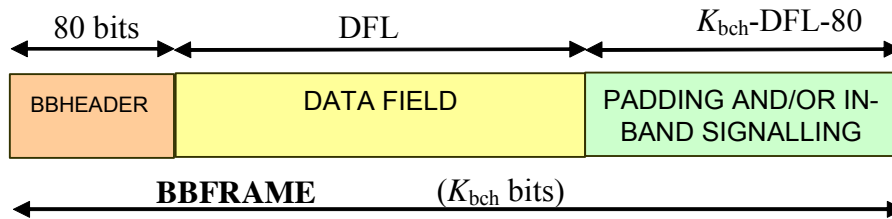
These modes are not defined (except for the case of TS, as described above).

## 5.2 Stream adaptation

Stream adaptation (see figures 2 and 9) provides:

- scheduling (for input mode 'B'), see clause 5.2.1;
- padding (see clause 5.2.2) to complete a constant length ( $K_{bch}$  bits) BBFRAME and/or to carry in-band signalling according to clause 5.2.3;
- scrambling (see clause 5.2.4) for energy dispersal.

The input stream to the stream adaptation module shall be a BBHEADER followed by a DATA FIELD. The output stream shall be a BBFRAME, as shown in figure 9.



**Figure 9: BBFRAME format at the output of the STREAM ADAPTER**

## 5.2.1 Scheduler

In order to generate the required L1 dynamic signalling information, the scheduler must decide exactly which cells of the final T2 signal will carry data belonging to which PLPs, as shown in figure 2(c). Although this operation has no effect on the data stream itself at this stage, the scheduler shall define the exact composition of the frame structure, as described in clause 8.

The scheduler works by counting the FEC blocks from each of the PLPs. Starting from the beginning of the Interleaving Frame (which corresponds to either one or more T2-frames - see clause 6.5), the scheduler counts separately the start of each FEC block received from each PLP. The scheduler then calculates the values of the dynamic parameters for each PLP for each T2-frame. This is described in more detail in clause 8 (or in the case of TFS, in annex E). The scheduler then forwards the calculated values for insertion as in-band signalling data, and to the L1 signalling generator.

The scheduler does not change the data in the PLPs whilst it is operating. Instead, the data will be buffered in preparation for frame building, typically in the time interleaver memories as described in clause 6.5.

## 5.2.2 Padding

$K_{bch}$  depends on the FEC rate, as reported in table 6. Padding may be applied in circumstances when the user data available for transmission is not sufficient to completely fill a BBFRAME, or when an integer number of UPs has to be allocated in a BBFRAME.

( $K_{bch} - DFL - 80$ ) zero bits shall be appended after the DATA FIELD. The resulting BBFRAME shall have a constant length of  $K_{bch}$  bits.

## 5.2.3 Use of the padding field for in-band signalling

In input mode 'B', the PADDING field may also be used to carry in-band signalling.

Two types of in-band signalling are defined: type A and type B. Future versions of the present document may define other types of in-band signalling. The PADDING field may contain an in-band signalling block of type A only, or of type B only, or a block of type A followed by a block of type B.

Type A signalling shall only be carried in the first BBFRAME of an Interleaving Frame and its presence shall be indicated by setting IN-BAND\_A\_FLAG field in L1-post signalling, defined in clause 7.2.3, to '1'. If IN-BAND\_A\_FLAG is set to '1', the in-band signalling block of type A shall immediately follow the data field of the relevant BBFRAME.

Type B signalling shall only be carried in the first BBFRAME of an Interleaving Frame and its presence shall be indicated by setting IN-BAND\_B\_FLAG field in L1-post signalling, defined in clause 7.2.3, to '1'.

If a BBFRAME carries type B signalling but not type A, the in-band type B signalling shall immediately follow the data field of the relevant BBFRAME.

If a BBFRAME carries both type A and type B signalling, the type A block be followed immediately by the type B block.

NOTE: For T2-Lite, in-band type B is always used (see annex I).

Any remaining bits of the BBFRAME following the last in-band signalling block are reserved.

Figure 10 illustrates the signalling format of the PADDING field when in-band signalling is delivered.

The first two bits of each in-band signalling block shall indicate the PADDING\_TYPE as given in table 3.

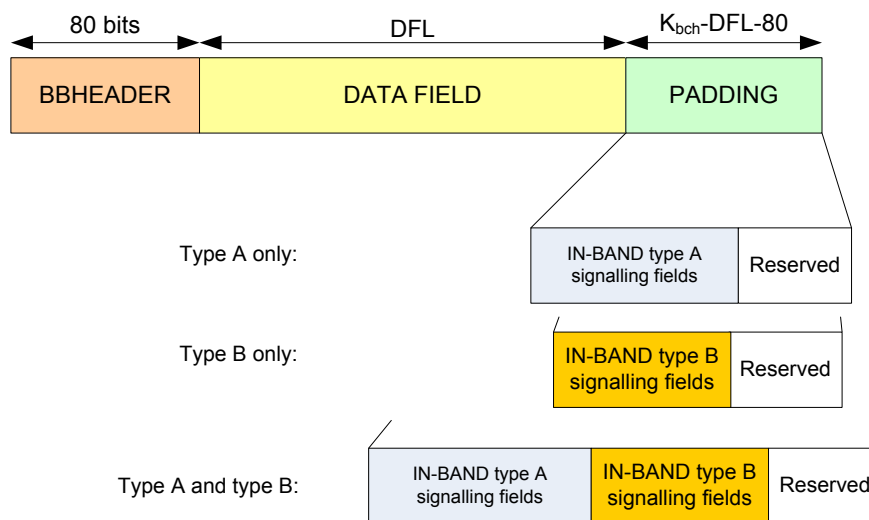
**Table 3: The mapping of PADDING types**

Value	Input stream format	Type
00	Any	In-band type A
01	TS or GFPS	In-band type B
01	GSE or GCS	Reserved for future use
10	Any	Reserved for future use
11	Any	Reserved for future use

NOTE: In-band type B has been added in such a way that receivers designed according to version 1.1.1 of the present document will find in-band type A signalling where expected and will not be affected by the presence of in-band type B signalling.

In-band type B shall not be used when the T2\_VERSION field is set to '0000'.

The format of an in-band type A block is given in clause 5.2.3.1. The format of an in-band type B block is given in clause 5.2.3.2.



**Figure 10: PADDING format at the output of the STREAM ADAPTER for in-band type A, B, or both**

### 5.2.3.1 In-band type A

An in-band signalling block carrying L1/L2 update information and co-scheduled information is defined as in-band type A. When IN-BAND\_A\_FLAG field in L1-post signalling, defined in clause 7.2.3, is set to '0', the in-band type A is not carried in the PADDING field. The use of in-band type A is mandatory for PLPs that appear in every T2-frame and for which one Interleaving Frame is mapped to one T2-frame (i.e. the values for  $P_1$  and  $I_{JUMP}$  for the current PLP are both equal to 1; see clauses 8.3.6.1 and 8.2).

The in-band type A block carrying L1 dynamic signalling for Interleaving Frame  $n+1$  (Interleaving Frame  $n+2$  in the case of TFS, see annex E) of a PLP or multiple PLPs is inserted in the PADDING field of the first BBFRAME of Interleaving Frame  $n$  of each PLP. If NUM\_OTHER\_PLP\_IN\_BAND=0 (see below), the relevant PLP carries only its own in-band L1 dynamic information. If NUM\_OTHER\_PLP\_IN\_BAND>0, it carries L1 dynamic information of other PLPs as well as its own information, for shorter channel switching time.

Table 4 indicates the detailed use of fields for in-band type A signalling.

**Table 4: Padding field mapping for in-band type A**

Field	Size
PADDING_TYPE ('00')	2 bits
PLP_L1_CHANGE_COUNTER	8 bits
RESERVED_1	8 bits
For $j=0..P_1-1$ {	
SUB_SLICE_INTERVAL	22 bits
START_RF_IDX	3 bits
CURRENT_PLP_START	22 bits
RESERVED_2	8 bits
}	
CURRENT_PLP_NUM_BLOCKS	10 bits
NUM_OTHER_PLP_IN_BAND	8 bits
For $i=0..NUM\_OTHER\_PLP\_IN\_BAND-1$ {	
PLP_ID	8 bits
PLP_START	22 bits
PLP_NUM_BLOCKS	10 bits
RESERVED_3	8 bits
}	
For $j=0..P_1-1$ {	
TYPE_2_START	22 bits
}	

**PADDING\_TYPE:** This 2-bit field indicates the type of the in-band signalling block and shall be set to '00' for type A. The mapping of different types is given in table 3.

**PLP\_L1\_CHANGE\_COUNTER:** This 8-bit field indicates the number of super-frames ahead where the configuration (i.e. the contents of the fields in the L1-pre signalling or the configurable part of the L1-post signalling) will change in a way that affects the PLPs referred to by this in-band signalling field. The next super-frame with changes in the configuration is indicated by the value signalled within this field. If this field is set to the value '0', it means that no scheduled change is foreseen.

E.g. value '1' indicates that there is change in the next super-frame. This counter shall always start counting down from a minimum value of 2.

**RESERVED\_1:** This 8-bit field is reserved for future use.

For the current PLP, the in-band signalling shall be given, in order of T2-frame index, for each of the  $P_1$  T2-frames to which the next Interleaving Frame is mapped (see clauses 6.5.1 and 8.3.6.1). In the case of TFS, the next-but-one Interleaving Frame shall be signalled. The following fields appear in the  $P_1$  loop:

**SUB\_SLICE\_INTERVAL:** This 22-bit field indicates the number of OFDM cells from the start of one sub-slice of one PLP to the start of the next sub-slice of the same PLP on the same RF channel for the relevant T2-frame. If the number of sub-slices per frame equals the number of RF channels, then the value of this field indicates the number of OFDM cells on one RF channel for the type 2 data PLPs in the relevant T2-frame. If there are no type 2 PLPs, this field shall be set to '0'. The use of this parameter is defined with greater detail in clause 8.3.6.3.3.

**START\_RF\_IDX:** This 3-bit field indicates the ID of the starting frequency of the TFS scheduled frame, for the relevant T2-frame, as described in annex E. The starting frequency within the TFS scheduled frame may change dynamically. When TFS is not used, the value of this field shall be set to '0'.

**CURRENT\_PLP\_START:** This 22-bit field signals the start position of the current PLP in the relevant T2-frame. The start position is specified using the addressing scheme described in clause 8.3.6.2.

**RESERVED\_2:** This 8-bit field is reserved for future use.

**CURRENT\_PLP\_NUM\_BLOCKS:** This 10-bit field indicates the number of FEC blocks used for the current PLP within the next Interleaving Frame (or the next-but-one Interleaving Frame in the case of TFS).



**NUM\_OTHER\_PLP\_IN\_BAND:** This 8-bit field indicates the number of other PLPs excluding the current PLP for which L1 dynamic information is delivered via the current in-band signalling. This mechanism shall only be used when the values for  $P_1$  and  $I_{JUMP}$  for the current PLP are both equal to 1 (otherwise NUM\_OTHER\_PLP\_IN\_BAND shall be set to zero and the loop will be empty).

The following fields appear in the NUM\_OTHER\_PLP\_IN\_BAND loop:

**PLP\_ID:** This 8-bit field identifies uniquely a PLP.

If the PLP\_ID corresponds to a PLP whose PLP\_TYPE (see clause 7.2.3.1) is one of the values reserved for future use, the remaining bits of this other PLP loop shall still be carried, and they too shall be reserved for future use and shall be ignored.

**PLP\_START:** This 22-bit field signals the start position of PLP\_ID in the next T2-frame (or the next-but-one T2-frame in the case of TFS). When PLP\_ID is not mapped to the relevant T2-frame, this field shall be set to '0'. The start position is specified using the addressing scheme described in clause 8.3.6.2.

**PLP\_NUM\_BLOCKS:** This 10-bit field indicates the number of FEC blocks for PLP\_ID contained in the Interleaving Frame which is mapped to the next T2-frame (or the Interleaving Frame which is mapped to the next-but-one T2-frame in the case of TFS). It shall have the same value for every T2-frame to which the Interleaving Frame is mapped. When PLP\_ID is not mapped to the next T2-frame (or the next-but-one T2-frame in the case of TFS), this field shall be set to '0'.

**RESERVED\_3:** This 8-bit field is reserved for future use.

**TYPE\_2\_START:** This 22-bit field indicates the start position of the first of the type 2 PLPs using the cell addressing scheme defined in clause 8.3.6.2. If there are no type 2 PLPs, this field shall be set to '0'. It has the same value on every RF channel, and with TFS can be used to calculate when the sub-slices of a PLP are 'folded' (see clause E.2.7.2.4). The value of TYPE\_2\_START shall be signalled for each of the  $P_1$  T2-frames to which the next Interleaving Frame is mapped (see clauses 6.5.1 and 8.3.6.1). In the case of TFS, the next-but-one Interleaving Frame shall be signalled.

If there is no user data for a PLP in a given Interleaving Frame, the scheduler shall either:

- allocate no blocks (previously indicated by PLP\_NUM\_BLOCKS equal to 0); or
- allocate one block (previously indicated by PLP\_NUM\_BLOCKS equal to 1), with DFL=0, to carry the in-band type A signalling (and the remainder of the BBFRAME will be filled with padding by the input processor).

NOTE 1: In the case when the value of PLP\_NUM\_BLOCKS referring to the current Interleaving Frame equals 0 (as signalled in a previous Interleaving Frame), the dynamic signalling normally carried in the in-band signalling for the relevant PLP will still be present in the L1 signalling in P2 (see clause 7.2.3.2), and may also be carried in the in-band signalling of another PLP.

NOTE 2: In order to allow in-band signalling to be used together with GSE [i.2] it is assumed that, for Baseband frames containing in-band signalling, the data field, containing the GSE packets, does not fill the entire Baseband frame capacity, but leaves space for a padding field including in-band signalling at the end of the Baseband frame.

### 5.2.3.2 In-band type B

For a PLP carrying TS or GFPS, an in-band type B block shall carry additional information related to the Input Processing for the PLP containing the type B block. In particular it shall contain extra ISSY information, to enable faster initial acquisition, related to the BBFRAME carrying the type B block. The use of In-band type B signalling is optional.

Table 5 shows the detailed use of fields for in-band type B signalling for TS or GFPS.

**Table 5: Padding field mapping for in-band type B**

Field	Size
PADDING_TYPE ('01')	2 bits
TTO	31 bits
FIRST_ISCR	22 bits
BUFS_UNIT	2 bits
BUFS	10 bits
TS_RATE	27 bits
RESERVED_B	8 bits

**PADDING\_TYPE:** This 2-bit field indicates the type of the in-band signalling block and shall be set to '01' for type B. The mapping of different types is given in table 3.

**TTO:** This 31-bit field shall signal directly the value of TTO (as defined in annex C) for the first UP that begins in the data field of the BBFRAME containing the type B block. If ISSY is not used for the PLP containing this block, this field shall be set to '0'.

**FIRST\_ISCR:** This 22-bit field shall give the  $ISCR_{long}$  value (see annex C) for the first UP that begins in the data field. If ISSY is not used for the PLP containing this block, this field shall be set to '0'.

**BUFS\_UNIT:** This 2-bit field shall indicate the unit used for the following BUFS field, as defined for the BUFS\_UNIT field in annex C. If ISSY is not used for the PLP containing this block, this field shall be set to '0'.

**BUFS:** This 10-bit field shall indicate the size of the receiver buffer assumed by the modulator for the relevant PLP, as defined for the BUFS field in annex C. If ISSY is not used for the PLP containing this block, this field shall be set to '0'.

**TS\_RATE:** This 27-bit field shall indicate the clock rate of the transport stream or GFPS being carried by the relevant PLP, in bits per second. If the actual clock rate is not an integer number of bits/s the value of TS\_RATE shall be rounded to the nearest integer.

NOTE: This value is not necessarily exact and receivers should make use of ISCR (as described in annex C) or buffer occupancy (as described in annex J) to maintain the correct output clock rate.

**RESERVED\_B:** This 8-bit field is reserved for future use.

For PLPs carrying GCS or GSE, the PADDING\_TYPE '01' is reserved for future use.

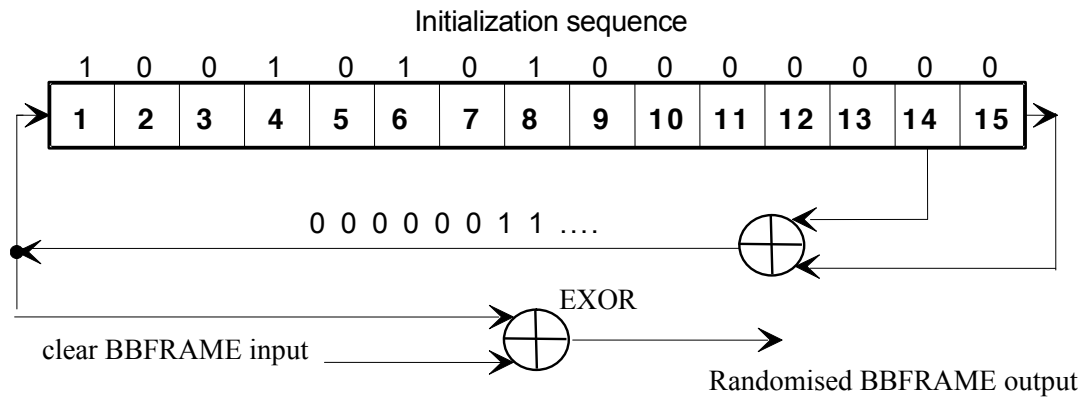
## 5.2.4 BB scrambling

The complete BBFRAME shall be randomized. The randomization sequence shall be synchronous with the BBFRAME, starting from the MSB and ending after  $K_{bch}$  bits.

The scrambling sequence shall be generated by the feed-back shift register of figure 11. The polynomial for the Pseudo Random Binary Sequence (PRBS) generator shall be:

$$1 + X^{14} + X^{15}$$

Loading of the sequence (10010101000000) into the PRBS register, as indicated in figure 11, shall be initiated at the start of every BBFRAME.



**Figure 11: Possible implementation of the PRBS encoder**

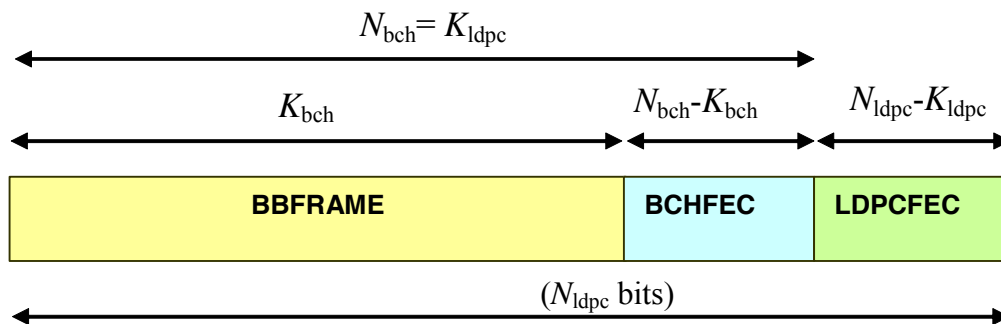
The L1-post signalling blocks may also be scrambled using the same scrambling sequence. The details of this are given in clause 7.3.2.1.

## 6 Bit-interleaved coding and modulation

### 6.1 FEC encoding

This sub-system shall perform outer coding (BCH), Inner Coding (LDPC) and Bit interleaving. The input stream shall be composed of BBFRAMEs and the output stream of FECFRAMEs.

Each BBFRAME ( $K_{\text{bch}}$  bits) shall be processed by the FEC coding subsystem, to generate a FECFRAME ( $N_{\text{ldpc}}$  bits). The parity check bits (BCHFEC) of the systematic BCH outer code shall be appended after the BBFRAME, and the parity check bits (LDPCFEC) of the inner LDPC encoder shall be appended after the BCHFEC field, as shown in figure 12.



**Figure 12: Format of data before bit interleaving**  
( $N_{\text{ldpc}} = 64\,800$  bits for normal FECFRAME,  $N_{\text{ldpc}} = 16\,200$  bits for short FECFRAME)

Table 6(a) gives the FEC coding parameters for the normal FECFRAME ( $N_{ldpc} = 64\,800$  bits) and table 6(b) for the short FECFRAME ( $N_{ldpc} = 16\,200$  bits).

**Table 6(a): Coding parameters (for normal FECFRAME  $N_{ldpc} = 64\,800$ )**

LDPC Code	BCH Uncoded Block $K_{bch}$	BCH coded block $N_{bch}$ LDPC Uncoded Block $K_{ldpc}$	BCH t-error correction	$N_{bch} - K_{bch}$	LDPC Coded Block $N_{ldpc}$
1/2	32 208	32 400	12	192	64 800
3/5	38 688	38 880	12	192	64 800
2/3	43 040	43 200	10	160	64 800
3/4	48 408	48 600	12	192	64 800
4/5	51 648	51 840	12	192	64 800
5/6	53 840	54 000	10	160	64 800

**Table 6(b): Coding parameters (for short FECFRAME  $N_{ldpc} = 16\,200$ )**

LDPC Code identifier	BCH Uncoded Block $K_{bch}$	BCH coded block $N_{bch}$ LDPC Uncoded Block $K_{ldpc}$	BCH t-error correction	$N_{bch} - K_{bch}$	Effective LDPC Rate $K_{ldpc}/16\,200$	LDPC Coded Block $N_{ldpc}$
1/4 (see note)	3 072	3 240	12	168	1/5	16 200
1/2	7 032	7 200	12	168	4/9	16 200
3/5	9 552	9 720	12	168	3/5	16 200
2/3	10 632	10 800	12	168	2/3	16 200
3/4	11 712	11 880	12	168	11/15	16 200
4/5	12 432	12 600	12	168	7/9	16 200
5/6	13 152	13 320	12	168	37/45	16 200

NOTE: This code rate is only used for protection of L1-pre signalling and not for data.

NOTE 1: For  $N_{ldpc} = 64\,800$  as well as for  $N_{ldpc} = 16\,200$  the LDPC code rate is given by  $K_{ldpc} / N_{ldpc}$ . In table 6(a) the LDPC code rates for  $N_{ldpc} = 64\,800$  are given by the values in the 'LDPC Code' column. In table 6(b) the LDPC code rates for  $N_{ldpc} = 16\,200$  are given by the values in the 'Effective LDPC rate' column, i.e. for  $N_{ldpc} = 16\,200$  the 'LDPC Code identifier' is *not* equivalent to the LDPC code rate.

NOTE 2: A slightly different set of codes are specified for use with T2-Lite – see annex I.

### 6.1.1 Outer encoding (BCH)

A t-error correcting BCH ( $N_{bch}, K_{bch}$ ) code shall be applied to each BBFRAME to generate an error protected packet. The BCH code parameters for  $N_{ldpc} = 64\,800$  are given in table 6(a) and for  $N_{ldpc} = 16\,200$  in table 6(b).

The generator polynomial of the t error correcting BCH encoder is obtained by multiplying the first t polynomials in table 7(a) for  $N_{ldpc} = 64\,800$  and in table 7(b) for  $N_{ldpc} = 16\,200$ .

**Table 7(a): BCH polynomials (for normal FECFRAME  $N_{ldpc} = 64\ 800$ )**

$g_1(x)$	$1+x^2+x^3+x^5+x^{16}$
$g_2(x)$	$1+x+x^4+x^5+x^6+x^8+x^{16}$
$g_3(x)$	$1+x^2+x^3+x^4+x^5+x^7+x^8+x^9+x^{10}+x^{11}+x^{16}$
$g_4(x)$	$1+x^2+x^4+x^6+x^9+x^{11}+x^{12}+x^{14}+x^{16}$
$g_5(x)$	$1+x+x^2+x^3+x^5+x^8+x^9+x^{10}+x^{11}+x^{12}+x^{16}$
$g_6(x)$	$1+x^2+x^4+x^5+x^7+x^8+x^9+x^{10}+x^{12}+x^{13}+x^{14}+x^{15}+x^{16}$
$g_7(x)$	$1+x^2+x^5+x^6+x^8+x^9+x^{10}+x^{11}+x^{13}+x^{15}+x^{16}$
$g_8(x)$	$1+x+x^2+x^5+x^6+x^8+x^9+x^{12}+x^{13}+x^{14}+x^{16}$
$g_9(x)$	$1+x^5+x^7+x^9+x^{10}+x^{11}+x^{16}$
$g_{10}(x)$	$1+x+x^2+x^5+x^7+x^8+x^{10}+x^{12}+x^{13}+x^{14}+x^{16}$
$g_{11}(x)$	$1+x^2+x^3+x^5+x^9+x^{11}+x^{12}+x^{13}+x^{16}$
$g_{12}(x)$	$1+x+x^5+x^6+x^7+x^9+x^{11}+x^{12}+x^{16}$

**Table 7(b): BCH polynomials (for short FECFRAME  $N_{ldpc} = 16\ 200$ )**

$g_1(x)$	$1+x+x^3+x^5+x^{14}$
$g_2(x)$	$1+x^6+x^8+x^{11}+x^{14}$
$g_3(x)$	$1+x+x^2+x^6+x^9+x^{10}+x^{14}$
$g_4(x)$	$1+x^4+x^7+x^8+x^{10}+x^{12}+x^{14}$
$g_5(x)$	$1+x^2+x^4+x^6+x^8+x^9+x^{11}+x^{13}+x^{14}$
$g_6(x)$	$1+x^3+x^7+x^8+x^9+x^{13}+x^{14}$
$g_7(x)$	$1+x^2+x^5+x^6+x^7+x^{10}+x^{11}+x^{13}+x^{14}$
$g_8(x)$	$1+x^5+x^8+x^9+x^{10}+x^{11}+x^{14}$
$g_9(x)$	$1+x+x^2+x^3+x^9+x^{10}+x^{14}$
$g_{10}(x)$	$1+x^3+x^6+x^9+x^{11}+x^{12}+x^{14}$
$g_{11}(x)$	$1+x^4+x^{11}+x^{12}+x^{14}$
$g_{12}(x)$	$1+x+x^2+x^3+x^5+x^6+x^7+x^8+x^{10}+x^{13}+x^{14}$

The bits of the baseband frame form the message bits  $M = (m_{K_{bch}-1}, m_{K_{bch}-2}, \dots, m_1, m_0)$  for BCH encoding, where  $m_{K_{bch}-1}$  is the first bit of the BBHEADER and  $m_0$  is the last bit of the BBFRAME (or padding field if present). BCH encoding of information bits  $M = (m_{K_{bch}-1}, m_{K_{bch}-2}, \dots, m_1, m_0)$  onto a codeword is achieved as follows:

- Multiply the message polynomial  $m(x) = m_{K_{bch}-1}x^{k_{bch}-1} + m_{K_{bch}-2}x^{k_{bch}-2} + \dots + m_1x + m_0$  by  $x^{N_{bch}-K_{bch}}$ .
- Divide  $x^{N_{bch}-K_{bch}}m(x)$  by  $g(x)$ , the generator polynomial. Let  $d(x) = d_{N_{bch}-K_{bch}-1}x^{N_{bch}-K_{bch}-1} + \dots + d_1x + d_0$  be the remainder.
- Construct the output codeword  $I$ , which forms the information word  $I$  for the LDPC coding, as follows:

$$I = (i_0, i_1, \dots, i_{N_{bch}-1}) = (m_{K_{bch}-1}, m_{K_{bch}-2}, \dots, m_1, m_0, d_{N_{bch}-K_{bch}-1}, d_{N_{bch}-K_{bch}-2}, \dots, d_1, d_0)$$

NOTE: The equivalent codeword polynomial is  $c(x) = x^{N_{bch}-K_{bch}}m(x) + d(x)$ .

## 6.1.2 Inner encoding (LDPC)

The LDPC encoder treats the output of the outer encoding,  $I = (i_0, i_1, \dots, i_{K_{ldpc}-1})$ , as an information block of size  $K_{ldpc} = N_{BCH}$ , and systematically encodes it onto a codeword  $\mathcal{A}$  of size  $N_{ldpc}$ , where:

$$\Lambda = \left( \lambda_0, \lambda_1, \lambda_2, \dots, \lambda_{N_{LDPC}-1} \right) \mathcal{T}^{-1}(i_0, i_1, \dots, i_{K_{ldpc}-1}, p_0, p_1, \dots, p_{N_{ldpc}-K_{ldpc}-1}).$$

The LDPC code parameters  $(N_{ldpc}, K_{ldpc})$  are given in table 6.

### 6.1.2.1 Inner coding for normal FECFRAME

The task of the encoder is to determine  $N_{ldpc} - K_{ldpc}$  parity bits  $(p_0, p_1, \dots, p_{N_{ldpc}-K_{ldpc}-1})$  for every block of  $k_{ldpc}$  information bits,  $(i_0, i_1, \dots, i_{K_{ldpc}-1})$ . The procedure is as follows:

- Initialize  $p_0 = p_1 = p_2 = \dots = p_{N_{ldpc}-K_{ldpc}-1} = 0$
- Accumulate the first information bit,  $i_0$ , at parity bit addresses specified in the first row of tables A.1 through A.6. For example, for rate 2/3 (see table A.3), (all additions are in GF(2)):

$$\begin{aligned} p_{317} &= p_{317} \oplus i_0 & p_{6700} &= p_{6700} \oplus i_0 \\ p_{2255} &= p_{2255} \oplus i_0 & p_{9101} &= p_{9101} \oplus i_0 \\ p_{2324} &= p_{2324} \oplus i_0 & p_{10057} &= p_{10057} \oplus i_0 \\ p_{2723} &= p_{2723} \oplus i_0 & p_{12739} &= p_{12739} \oplus i_0 \\ p_{3538} &= p_{3538} \oplus i_0 & p_{17407} &= p_{17407} \oplus i_0 \\ p_{3576} &= p_{3576} \oplus i_0 & p_{21039} &= p_{21039} \oplus i_0 \\ p_{6194} &= p_{6194} \oplus i_0 \end{aligned}$$

- For the next 359 information bits,  $i_m, m = 1, 2, \dots, 359$  accumulate  $i_m$  at parity bit addresses  $\{x + m \bmod 360 \times Q_{ldpc}\} \bmod (N_{ldpc} - K_{ldpc})$  where  $x$  denotes the address of the parity bit accumulator corresponding to the first bit  $i_0$ , and  $Q_{ldpc}$  is a code rate dependent constant specified in table 8(a). Continuing with the example,  $Q_{ldpc} = 60$  for rate 2/3. So for example for information bit  $i_1$ , the following operations are performed:

$$\begin{aligned} p_{377} &= p_{377} \oplus i_1 & p_{6760} &= p_{6760} \oplus i_1 \\ p_{2315} &= p_{2315} \oplus i_1 & p_{9161} &= p_{9161} \oplus i_1 \\ p_{2384} &= p_{2384} \oplus i_1 & p_{10117} &= p_{10117} \oplus i_1 \\ p_{2783} &= p_{2783} \oplus i_1 & p_{12799} &= p_{12799} \oplus i_1 \\ p_{3598} &= p_{3598} \oplus i_1 & p_{17467} &= p_{17467} \oplus i_1 \\ p_{3636} &= p_{3636} \oplus i_1 & p_{21099} &= p_{21099} \oplus i_1 \\ p_{6254} &= p_{6254} \oplus i_1 \end{aligned}$$

- For the 361<sup>st</sup> information bit  $i_{360}$ , the addresses of the parity bit accumulators are given in the second row of the tables A.1 through A.6. In a similar manner the addresses of the parity bit accumulators for the following 359 information bits  $i_m, m = 361, 362, \dots, 719$  are obtained using the formula  $\{x + (m \bmod 360) \times Q_{ldpc}\} \bmod (N_{ldpc} - K_{ldpc})$  where  $x$  denotes the address of the parity bit accumulator corresponding to the information bit  $i_{360}$ , i.e. the entries in the second row of the tables A.1 through A.6.
- In a similar manner, for every group of 360 new information bits, a new row from tables A.1 through A.6 are used to find the addresses of the parity bit accumulators.

After all of the information bits are exhausted, the final parity bits are obtained as follows:

- Sequentially perform the following operations starting with  $i = 1$ .

$$p_i = p_i \oplus p_{i-1}, \quad i = 1, 2, \dots, N_{ldpc} - K_{ldpc} - 1$$

- Final content of  $p_i, i = 0, 1, \dots, N_{ldpc} - K_{ldpc} - 1$  is equal to the parity bit  $p_i$ .

**Table 8(a):  $Q_{ldpc}$  values for normal frames**

Code Rate	$Q_{ldpc}$
1/2	90
3/5	72
2/3	60
3/4	45
4/5	36
5/6	30

### 6.1.2.2 Inner coding for short FECFRAME

$K_{ldpc}$  BCH encoded bits shall be systematically encoded to generate  $N_{ldpc}$  bits as described in clause 6.1.2.1, replacing table 8(a) with table 8(b), the tables of annex A with the tables of annex B.

**Table 8(b):  $Q_{ldpc}$  values for short frames**

Code Rate	$Q_{ldpc}$
1/4	36
1/3	30
2/5	27
1/2	25
3/5	18
2/3	15
3/4	12
4/5	10
5/6	8

### 6.1.3 Bit Interleaver (for 16-QAM, 64-QAM and 256-QAM)

The output  $A$  of the LDPC encoder shall be bit interleaved, which consists of parity interleaving followed by column twist interleaving. The parity interleaver output is denoted by  $U$  and the column twist interleaver output by  $V$ .

In the parity interleaving part, parity bits are interleaved by:

$$\begin{aligned} u_i &= \lambda_i \text{ for } 0 \leq i < K_{ldpc} \text{ (information bits are not interleaved.)} \\ u_{K_{ldpc}+360t+s} &= \lambda_{K_{ldpc}+Q_{ldpc} \cdot s+t} \text{ for } 0 \leq s < 360, 0 \leq t < Q_{ldpc} \end{aligned} ;$$

where  $Q_{ldpc}$  is defined in table 8(a)/(b).

NOTE: For T2-Lite, parity interleaving only is also applied to QPSK modulation for the code rates 1/3 and 2/5 only (see annex I).

The configuration of the column twist interleaving for each modulation format is specified in table 9.

**Table 9: Bit Interleaver structure**

Modulation	Rows $N_r$		Columns $N_c$
	$N_{ldpc} = 64\ 800$	$N_{ldpc} = 16\ 200$	
16-QAM	8 100	2 025	8
64-QAM	5 400	1 350	12
256-QAM	4 050	-	16
	-	2 025	8

In the column twist interleaving part, the data bits  $u_i$  from the parity interleaver are serially written into the column-twist interleaver column-wise, and serially read out row-wise (the MSB of BBHEADER is read out first) as shown in figure 13, where the write start position of each column is twisted by  $t_c$  according to table 10. This interleaver is described by the following:

The input bit  $u_i$  with index  $i$ , for  $0 \leq i < N_{ldpc}$ , is written to column  $c_i$ , row  $r_i$  of the interleaver, where:

$$\begin{aligned} c_i &= i \operatorname{div} N_r \\ r_i &= (i + t_{c_i}) \operatorname{mod} N_r \end{aligned}$$

The output bit  $v_j$  with index  $j$ , for  $0 \leq j < N_{ldpc}$ , is read from row  $r_j$ , column  $c_j$ , where:

$$\begin{aligned} r_j &= j \operatorname{div} N_c \\ c_j &= j \operatorname{mod} N_c \end{aligned}$$

So for 64-QAM and  $N_{ldpc} = 64\ 800$ , the output bit order of column twist interleaving would be:

$$\langle \langle 0, v_1, v_2, \dots, v_{64799} \rangle \rangle \Rightarrow \langle \langle 0, u_{5400}, u_{16198}, \dots, u_{53992}, u_{59231}, u_{64790} \rangle \rangle$$

A longer list of the indices on the right hand side, illustrating all 12 columns, is: 0, 5 400, 16 198, 21 598, 26 997, 32 396, 37 796, 43 195, 48 595, 53 993, 59 392, 64 791, ..... 5 399, 10 799, 16 197, 21 597, 26 996, 32 395, 37 795, 43 194, 48 594, 53 992, 59 391, 64 790.



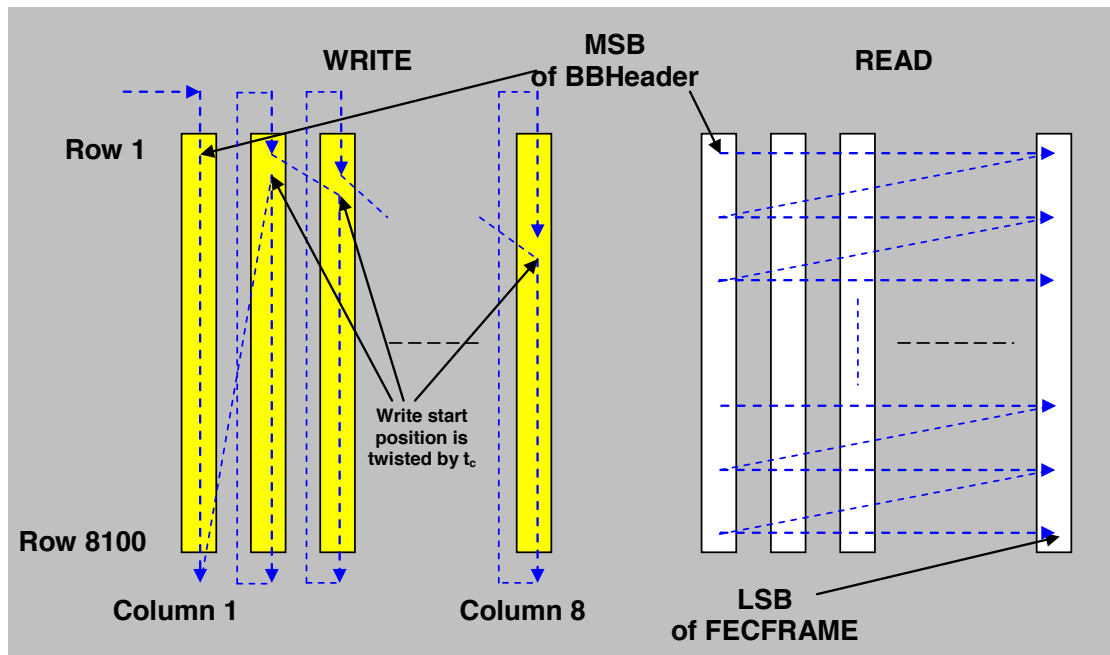


Figure 13: Bit Interleaving scheme for normal FECFRAME length and 16-QAM

Table 10: Column twisting parameter  $t_c$

Modulation	Columns $N_c$	$N_{ldpc}$	Twisting parameter $t_c$															
			Col. 0	1	2	3	4	5	6	7	8	9	10	11	12	13	14	15
16-QAM	8	64 800	0	0	2	4	4	5	7	7	-	-	-	-	-	-	-	-
		16 200	0	0	0	1	7	20	20	21	-	-	-	-	-	-	-	-
64-QAM	12	64 800	0	0	2	2	3	4	4	5	5	7	8	9	-	-	-	-
		16 200	0	0	0	2	2	2	3	3	3	6	7	7	-	-	-	-
256-QAM	16	64 800	0	2	2	2	2	3	7	15	16	20	22	22	27	27	28	32
	8	16 200	0	0	0	1	7	20	20	21	-	-	-	-	-	-	-	-

## 6.2 Mapping bits onto constellations

Each FECFRAME (which is a sequence of 64 800 bits for normal FECFRAME, or 16 200 bits for short FECFRAME), shall be mapped to a coded and modulated FEC block by first de-multiplexing the input bits into parallel cell words and then mapping these cell words into constellation values. The number of output data cells and the effective number of bits per cell  $\eta_{MOD}$  is defined by table 11. De-multiplexing is performed according to clause 6.2.1 and constellation mapping is performed according to clause 6.2.2.

Table 11: Parameters for bit-mapping into constellations

LDPC block length ( $N_{ldpc}$ )	Modulation mode	$\eta_{MOD}$	Number of output data cells
64 800	256-QAM	8	8 100
	64-QAM	6	10 800
	16-QAM	4	16 200
	QPSK	2	32 400
16 200	256-QAM	8	2 025
	64-QAM	6	2 700
	16-QAM	4	4 050
	QPSK	2	8 100

## 6.2.1 Bit to cell word de-multiplexer

The bit-stream  $v_{di}$  from the bit interleaver is de-multiplexed into  $N_{substreams}$  sub-streams, as shown in figure 14. The value of  $N_{substreams}$  is defined in table 12.

**Table 12: Number of sub-streams in de-multiplexer**

Modulation	$N_{ldpc}$	Number of sub-streams, $N_{substreams}$
QPSK	Any	2
16-QAM	Any	8
64-QAM	Any	12
256-QAM	64 800	16
	16 200	8

The de-multiplexing is defined as a mapping of the bit-interleaved input bits,  $v_{di}$  onto the output bits  $b_{e,do}$ , where:

$do = di \text{ div } N_{substreams}$ ;

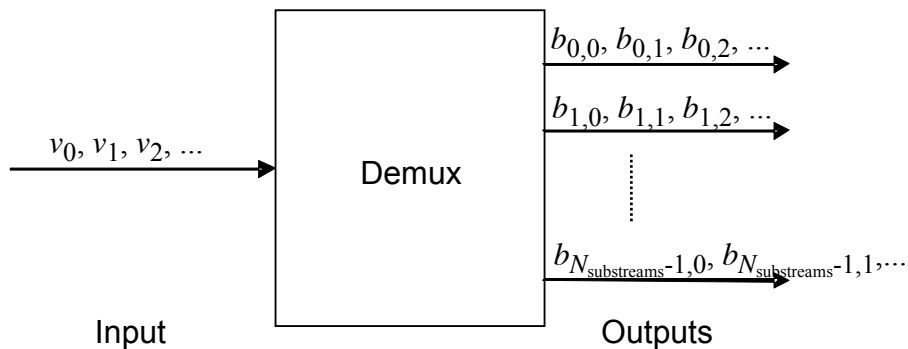
$e$  is the de-multiplexed bit substream number ( $0 \leq e < N_{substreams}$ ), which depends on  $di$  as defined in table 13;

$v_{di}$  is the input to the de-multiplexer;

$di$  is the input bit number;

$b_{e,do}$  is the output from the de-multiplexer;

$do$  is the bit number of a given stream at the output of the de-multiplexer.



**Figure 14: De-multiplexing of bits into sub-streams**

Table 13(a): Parameters for de-multiplexing of bits to sub-streams for code rates 1/2, 3/4, 4/5 and 5/6

<b>Modulation format</b>	<b>QPSK</b>															
Input bit-number, $di \bmod N_{substreams}$	0	1														
Output bit-number, $e$	0	1														
<b>Modulation format</b>	<b>16-QAM</b>															
Input bit-number, $di \bmod N_{substreams}$	0	1	2	3	4	5	6	7								
Output bit-number, $e$	7	1	4	2	5	3	6	0								
<b>Modulation format</b>	<b>64-QAM</b>															
Input bit-number, $di \bmod N_{substreams}$	0	1	2	3	4	5	6	7	8	9	10	11				
Output bit-number, $e$	11	7	3	10	6	2	9	5	1	8	4	0				
<b>Modulation format</b>	<b>256-QAM (<math>N_{dpc} = 64\ 800</math>)</b>															
Input bit-number, $di \bmod N_{substreams}$	0	1	2	3	4	5	6	7	8	9	10	11	12	13	14	15
Output bit-number, $e$	15	1	13	3	8	11	9	5	10	6	4	7	12	2	14	0
<b>Modulation format</b>	<b>256-QAM (<math>N_{dpc} = 16\ 200</math>)</b>															
Input bit-number, $di \bmod N_{substreams}$	0	1	2	3	4	5	6	7								
Output bit-number, $e$	7	3	1	5	2	6	4	0								

Table 13(b): Parameters for de-multiplexing of bits to sub-streams for code rate 3/5 only

<b>Modulation format</b>	<b>QPSK</b>															
Input bit-number, $di \bmod N_{substreams}$	0	1														
Output bit-number, $e$	0	1														
<b>Modulation format</b>	<b>16-QAM (<math>N_{ldpc} = 64\ 800</math>)</b>															
Input bit-number, $di \bmod N_{substreams}$	0	1	2	3	4	5	6	7								
Output bit-number, $e$	0	5	1	2	4	7	3	6								
<b>Modulation format</b>	<b>16-QAM (<math>N_{ldpc} = 16\ 200</math>)</b>															
Input bit-number, $di \bmod N_{substreams}$	0	1	2	3	4	5	6	7								
Output bit-number, $e$	7	1	4	2	5	3	6	0								
<b>Modulation format</b>	<b>64-QAM (<math>N_{ldpc} = 64\ 800</math>)</b>															
Input bit-number, $di \bmod N_{substreams}$	0	1	2	3	4	5	6	7	8	9	10	11				
Output bit-number, $e$	2	7	6	9	0	3	1	8	4	11	5	10				
<b>Modulation format</b>	<b>64-QAM (<math>N_{ldpc} = 16\ 200</math>)</b>															
Input bit-number, $di \bmod N_{substreams}$	0	1	2	3	4	5	6	7	8	9	10	11				
Output bit-number, $e$	11	7	3	10	6	2	9	5	1	8	4	0				
<b>Modulation format</b>	<b>256-QAM (<math>N_{ldpc} = 64\ 800</math>)</b>															
Input bit-number, $di \bmod N_{substreams}$	0	1	2	3	4	5	6	7	8	9	10	11	12	13	14	15
Output bit-number, $e$	2	11	3	4	0	9	1	8	10	13	7	14	6	15	5	12
<b>Modulation format</b>	<b>256-QAM (<math>N_{ldpc} = 16\ 200</math>)</b>															
Input bit-number, $di \bmod N_{substreams}$	0	1	2	3	4	5	6	7								
Output bit-number, $e$	7	3	1	5	2	6	4	0								

Table 13(c): Parameters for de-multiplexing of bits to sub-streams for code rate 2/3 only

Modulation format	QPSK															
Input bit-number, $di \bmod N_{substreams}$	0	1														
Output bit-number, $e$	0	1														
Modulation format	16-QAM															
Input bit-number, $di \bmod N_{substreams}$	0	1	2	3	4	5	6	7								
Output bit-number, $e$	7	1	4	2	5	3	6	0								
Modulation format	64-QAM															
Input bit-number, $di \bmod N_{substreams}$	0	1	2	3	4	5	6	7	8	9	10	11				
Output bit-number, $e$	11	7	3	10	6	2	9	5	1	8	4	0				
Modulation format	256-QAM ( $N_{ldpc} = 64\ 800$ )															
Input bit-number, $di \bmod N_{substreams}$	0	1	2	3	4	5	6	7	8	9	10	11	12	13	14	15
Output bit-number, $e$	7	2	9	0	4	6	13	3	14	10	15	5	8	12	11	1
Modulation format	256-QAM ( $N_{ldpc} = 16\ 200$ )															
Input bit-number, $di \bmod N_{substreams}$	0	1	2	3	4	5	6	7								
Output bit-number, $e$	7	3	1	5	2	6	4	0								

NOTE 1: Table 13(c) is the same as table 13(a) except for the modulation format 256-QAM with  $N_{ldpc} = 64\ 800$ .

NOTE 2: Additional demultiplexers for code rates 1/3 and 2/5 are defined for T2-Lite – see annex I.

Except for QPSK ( $N_{ldpc} = 64\ 800$  or  $16\ 200$ ) and 256-QAM ( $N_{ldpc} = 16\ 200$  only), the words of width  $N_{substreams}$  are split into two cell words of width  $\eta_{MOD} = N_{substreams} / 2$  at the output of the demultiplexer. The first  $\eta_{mod} = N_{substreams} / 2$  bits  $[b_{0,do} \cdot b_{N_{substreams}/2-1,do}]$  form the first of a pair of output cell words  $[y_{0,2do} \cdot y_{\eta_{mod}-1,2do}]$  and the remaining output bits  $[b_{N_{substreams}/2,do} \cdot b_{N_{substreams}-1,do}]$  form the second output cell word  $[y_{0,2do+1} \cdot y_{\eta_{mod}-1,2do+1}]$  fed to the constellation mapper.

In the case of QPSK ( $N_{ldpc} = 64\ 800$  or  $16\ 200$ ) and 256-QAM ( $N_{ldpc} = 16\ 200$  only), the words of width  $N_{substreams}$  from the demultiplexer form the output cell words and are fed directly to the constellation mapper, so:

$$[y_{0,do} \cdot y_{\eta_{mod}-1,do}] = [b_{0,do} \cdot b_{N_{substreams}-1,do}]$$

## 6.2.2 Cell word mapping into I/Q constellations

Each cell word  $(y_{0,q} \cdot y_{\eta_{mod}-1,q})$  from the demultiplexer in clause 6.2.1 shall be modulated using either QPSK, 16-QAM, 64-QAM or 256-QAM constellations to give a constellation point  $z_q$  prior to normalization.

BPSK is only used for the L1 signalling (see clause 7.3.3.2) but the constellation mapping is specified here.

The exact values of the real and imaginary components  $\text{Re}(z_q)$  and  $\text{Im}(z_q)$  for each combination of the relevant input bits  $y_{e,q}$  are given in tables 14(a) to 14(i) for the various constellations.

**Table 14(a): Constellation mapping for BPSK**

$y_{0,q}$	1	0
$\text{Re}(z_q)$	-1	1
$\text{Im}(z_q)$	0	0

**Table 14(b): Constellation mapping for real part of QPSK**

$y_{0,q}$	1	0
$\text{Re}(z_q)$	-1	1

**Table 14(c): Constellation mapping for imaginary part of QPSK**

$y_{1,q}$	1	0
$\text{Im}(z_q)$	-1	1

**Table 14(d): Constellation mapping for real part of 16-QAM**

$y_{0,q}$	1	1	0	0
$y_{2,q}$	0	1	1	0
$\text{Re}(z_q)$	-3	-1	1	3

**Table 14(e): Constellation mapping for imaginary part of 16-QAM**

$y_{1,q}$	1	1	0	0
$y_{3,q}$	0	1	1	0
$\text{Im}(z_q)$	-3	-1	1	3

**Table 14(f): Constellation mapping for real part of 64-QAM**

$y_{0,q}$	1	1	1	1	0	0	0	0
$y_{2,q}$	0	0	1	1	1	1	0	0
$y_{4,q}$	0	1	1	0	0	1	1	0
$\text{Re}(z_q)$	-7	-5	-3	-1	1	3	5	7

**Table 14(g): Constellation mapping for imaginary part of 64-QAM**

$y_{1,q}$	1	1	1	1	0	0	0	0
$y_{3,q}$	0	0	1	1	1	1	0	0
$y_{5,q}$	0	1	1	0	0	1	1	0
$\text{Im}(z_q)$	-7	-5	-3	-1	1	3	5	7

**Table 14(h): Constellation mapping for real part of 256-QAM**

$y_{0,q}$	1	1	1	1	1	1	1	1	0	0	0	0	0	0	0	0
$y_{2,q}$	0	0	0	0	1	1	1	1	1	1	1	1	0	0	0	0
$y_{4,q}$	0	0	1	1	1	1	0	0	0	0	1	1	1	1	0	0
$y_{6,q}$	0	1	1	0	0	1	1	0	0	1	1	0	0	1	1	0
$\text{Re}(z_q)$	-15	-13	-11	-9	-7	-5	-3	-1	1	3	5	7	9	11	13	15

**Table 14(i): Constellation mapping for imaginary part of 256-QAM**

$y_{1,q}$	1	1	1	1	1	1	1	1	0	0	0	0	0	0	0	0
$y_{3,q}$	0	0	0	0	1	1	1	1	1	1	1	1	0	0	0	0
$y_{5,q}$	0	0	1	1	1	1	0	0	0	0	1	1	1	1	0	0
$y_{7,q}$	0	1	1	0	0	1	1	0	0	1	1	0	0	1	1	0
$\text{Im}(z_q)$	-15	-13	-11	-9	-7	-5	-3	-1	1	3	5	7	9	11	13	15

The constellations, and the details of the Gray mapping applied to them, are illustrated in figures 15 and 16.

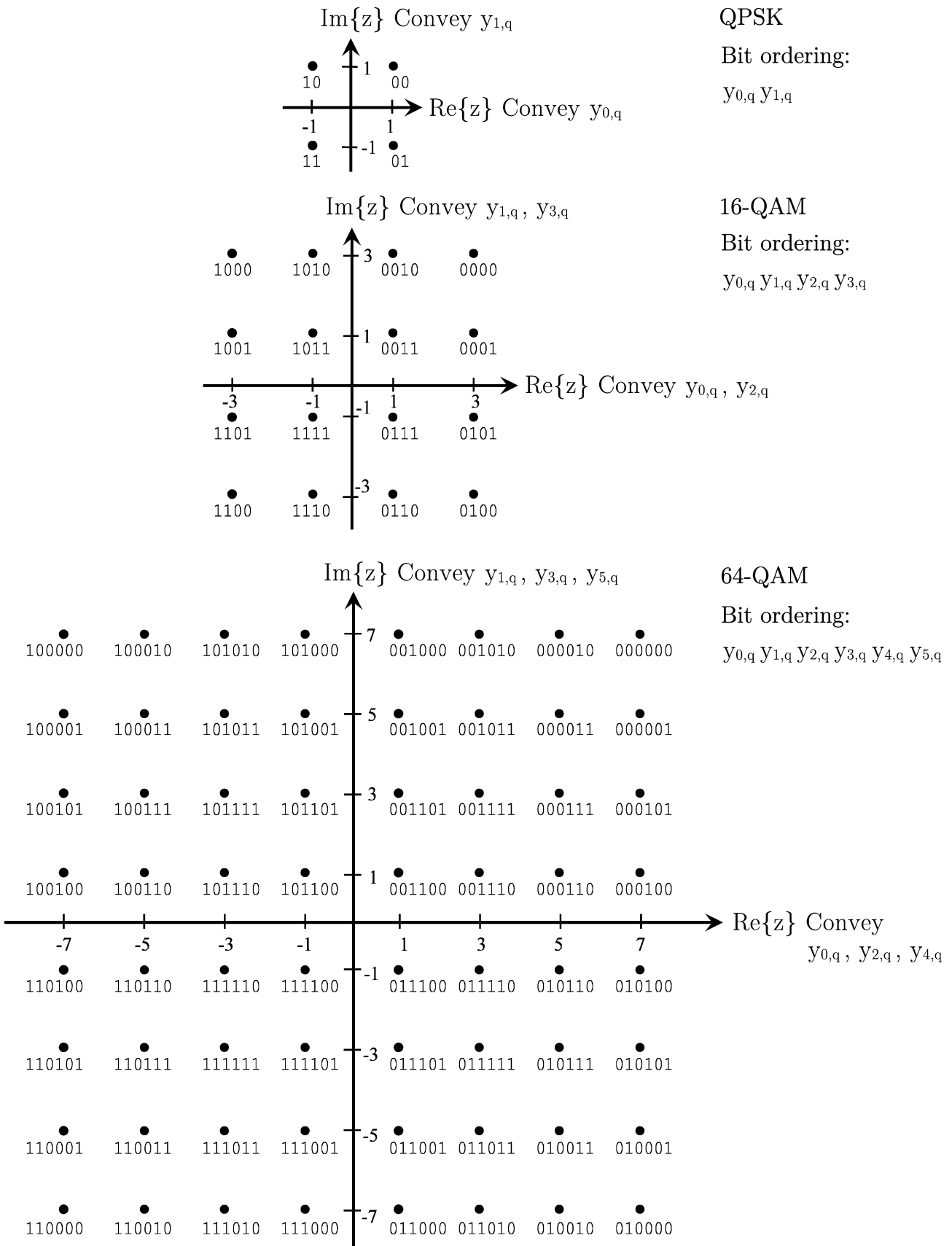


Figure 15: The QPSK, 16-QAM and 64-QAM mappings and the corresponding bit patterns





## 6.3 Constellation Rotation and Cyclic Q Delay

When constellation rotation is used, the normalized cell values of each FEC block  $F=(f_0, f_1, \dots, f_{N_{cells}-1})$ , coming from the constellation mapper (see clause 6.2.2) are rotated in the complex plane and the imaginary part cyclically delayed by one cell within a FEC block.  $N_{cells}$  is the number of cells per FEC block and is given in table 17. The output cells  $G=(g_0, g_1, \dots, g_{N_{cells}-1})$  are given by:

$$g_0 = \text{Re}(R_{RQD}f_0) + j \text{Im}(R_{RQD}f_{N_{cells}-1}),$$

$$g_q = \text{Re}(R_{RQD}f_q) + j \text{Im}(R_{RQD}f_{q-1}), \quad q=1, 2, \dots, N_{cells}-1,$$

where the rotation phasor  $R_{RQD} = e^{j\frac{2\pi\Phi}{360}}$ . The rotation angle  $\Phi$  depends on the modulation and is given in table 16.

**Table 16: Rotation angle for each modulation type**

Modulation	QPSK	16-QAM	64-QAM	256-QAM
$\Phi$ (degrees)	29,0	16,8	8,6	atan (1/16)

where atan(1/16) denotes the arctangent of 1/16 expressed in degrees.

Constellation rotation shall only be used for the common PLPs and the data PLPs and never for the cells of the L1 signalling. When constellation rotation is not used (i.e. PLP\_ROTATION=0, see clause 7.2.3.1), the cells are passed onto the cell interleaver unmodified, i.e.  $g_q=f_q$ .

NOTE: Constellation rotation is not used with 256-QAM for the T2-Lite profile – see annex I.

## 6.4 Cell Interleaver

The Pseudo Random Cell Interleaver (CI), which is illustrated in figure 17, shall uniformly spread the cells in the FEC codeword, to ensure in the receiver an uncorrelated distribution of channel distortions and interference along the FEC codewords, and shall differently "rotate" the interleaving sequence in each of the FEC blocks of one Time Interleaver Block (see clause 6.5).

The input of the CI,  $G(r)=(g_{r,0}, g_{r,1}, g_{r,2}, \dots, g_{r,N_{cells}-1})$  shall be the data cells ( $g_0, g_1, g_2, \dots, g_{N_{cells}-1}$ ) of the FEC block of index 'r', generated by the constellation rotation and cyclic Q delay (see clause 6.3), 'r' represents the incremental index of the FEC block within the TI-block and is reset to zero at the beginning of each TI-block. When time interleaving is not used, the value of 'r' shall be 0 for every FEC block. The output of the CI shall be a vector  $D(r) = (d_{r,0}, d_{r,1}, d_{r,2}, \dots, d_{r,N_{cells}-1})$  defined by:

$$d_{r,L_r(q)} = g_{r,q} \text{ for each } q = 0, 1, \dots, N_{cells}-1,$$

where  $N_{cells}$  is the number of output data cells per FEC block as defined by table 17 and  $L_r(q)$  is a permutation function applied to FEC block  $r$  of the TI-block.

$L_r(q)$  is based on a maximum length sequence, of degree  $(N_d-1)$ , where  $N_d = \lceil \log_2(N_{cells}) \rceil$ , plus MSB toggling at each new address generation. When an address is generated larger than or equal to  $N_{cells}$ , it is discarded and a new address is generated. To have different permutations for different FEC blocks, a constant shift (modulo  $N_{cells}$ ) is added to the permutation, generated as a bit-reversed  $N_d$ -bit sequence, with values greater than or equal to  $N_{cells}$  discarded.

The permutation function  $L_r(q)$  is given by:

$$L_r(q) = [L_0(q) + P(r)] \text{ mod } N_{cells},$$

where  $L_0(q)$  is the basic permutation function (used for the first FEC block of a TI-block) and  $P(r)$  is the shift value to be used in FEC block  $r$  of the TI-block.

The basic permutation function  $L_0(q)$  is defined by the following algorithm.

An  $N_d$  bit binary word  $S_i$  is defined as follows:

For all  $i$ ,

$$S_i[N_d-1] = (i \bmod 2) \text{ // (toggling of top bit)}$$

$i = 0, 1$ :

$$S_i[N_d-2, N_d-3, \dots, 1, 0] = 0, 0, \dots, 0, 0$$

$i = 2$ :

$$S_2[N_d-2, N_d-3, \dots, 1, 0] = 0, 0, \dots, 0, 1$$

$2 < i < 2^{N_d}$  :

$$S_i[N_d-3, N_d-4, \dots, 1, 0] = S_{i-1}[N_d-2, N_d-3, \dots, 2, 1];$$

$$\text{for } N_d = 11: S_i[9] = S_{i-1}[0] \oplus S_{i-1}[3]$$

$$\text{for } N_d = 12: S_i[10] = S_{i-1}[0] \oplus S_{i-1}[2]$$

$$\text{for } N_d = 13: S_i[11] = S_{i-1}[0] \oplus S_{i-1}[1] \oplus S_{i-1}[4] \oplus S_{i-1}[6]$$

$$\text{for } N_d = 14: S_i[12] = S_{i-1}[0] \oplus S_{i-1}[1] \oplus S_{i-1}[4] \oplus S_{i-1}[5] \oplus S_{i-1}[9] \oplus S_{i-1}[11]$$

$$\text{for } N_d = 15: S_i[13] = S_{i-1}[0] \oplus S_{i-1}[1] \oplus S_{i-1}[2] \oplus S_{i-1}[12].$$

The sequence  $L_0(q)$  is then generated by discarding values of  $S_i$  greater than or equal to  $N_{\text{cells}}$  as defined in the following algorithm:

$$q = 0;$$

$$\text{for } (i = 0; i < 2^{N_d}; i = i + 1)$$

{

$$L_0(q) = \sum_{j=0}^{N_d-1} S_i(j) \cdot 2^j ;$$

$$\text{if } (L_0(q) < N_{\text{cells}})$$

$$q = q + 1;$$

}

The shift  $P(r)$  to be applied in FEC block index  $r$  is calculated by the following algorithm. The FEC block index  $r$  is the index of the FEC block within the TI-block and counts up to  $N_{FEC\_TI}(n, s) - 1$ , where  $N_{FEC\_TI}(n, s)$  is the number of FEC blocks in TI-block index 's' of Interleaving Frame 'n' (see clause 6.5.2).  $P(r)$  is the conversion to decimal of the bit-reversed value of a counter  $k$  in binary notation over  $N_d$  bits. The counter is incremented if the bit-reversed value is too great.

$$k = 0;$$

$$\text{for } (r = 0; r < N_{FEC\_TI}(n, s); r++)$$

{

$$P(r) = N_{\text{cells}};$$

while ( $P(r) \geq N_{cells}$ )

{

$$P(r) = \sum_{j=0}^{N_d-1} \left[ \frac{k - \left\lfloor \frac{k}{2^{j+1}} \right\rfloor 2^{j+1}}{2^j} \right] \cdot 2^{N_d-1-j};$$

$k = k+1;$

}

}

So for  $N_{cells} = 10\,800$ ,  $N_d = 14$ , and the shift  $P(r)$  to be added to the permutation for  $r = 0, 1, 2, 3$ , etc. would be 0, 8 192, 4 096, 2 048, 10 240, 6 144, 1 024, 9 216, etc.

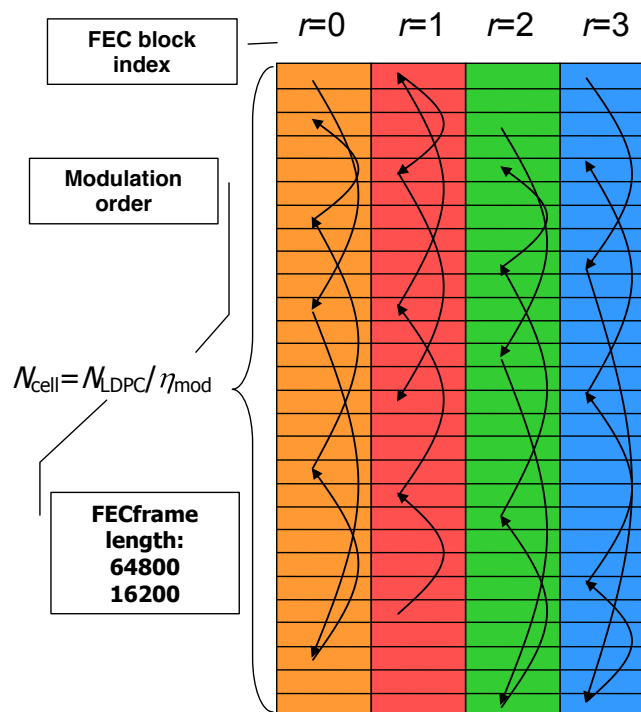


Figure 17: Cell Interleaving scheme

## 6.5 Time Interleaver

The time interleaver (TI) shall operate at PLP level. The parameters of the time interleaving may be different for different PLPs within a T2 system. When time interleaving is not used for a PLP (i.e. when the L1-post signalling parameter TIME\_IL\_LENGTH is set to 0, see clause 7.2.3), the remainder of clause 6.5, and clauses 6.5.1 to 6.5.4 do not apply, but clause 6.5.5 applies instead.

The FEC blocks from the cell interleaver for each PLP shall be grouped into Interleaving Frames (which are mapped onto one or more T2-frames). Each Interleaving Frame shall contain a dynamically variable whole number of FEC blocks. The number of FEC blocks in the Interleaving Frame of index  $n$  is denoted by  $N_{BLOCKS\_IF}(n)$  and is signalled as PLP\_NUM\_BLOCKS in the L1 dynamic signalling.

$N_{BLOCKS}$  may vary from a minimum value of 0 to a maximum value  $N_{BLOCKS\_IF\_MAX}$ .  $N_{BLOCKS\_IF\_MAX}$  is signalled in the configurable L1 signalling as PLP\_NUM\_BLOCKS\_MAX. The largest value this may take is 1 023.

Each Interleaving Frame is either mapped directly onto one T2-frame or spread out over several T2-frames as described in clause 6.5.1. Each Interleaving Frame is also divided into one or more ( $N_{TI}$ ) TI-blocks, where a TI-block corresponds to one usage of the time interleaver memory, as described in clause 6.5.2. The TI-blocks within an Interleaving Frame can contain a slightly different number of FEC blocks. If an Interleaving Frame is divided into multiple TI-blocks, it shall be mapped to only one T2-frame.

There are therefore three options for time interleaving for each PLP:

- 1) Each Interleaving Frame contains one TI-block and is mapped directly to one T2-frame as shown in figure 18(a). This option is signalled in the L1-signalling by  $TIME\_IL\_TYPE='0'$  and  $TIME\_IL\_LENGTH='1'$ .
- 2) Each Interleaving Frame contains one TI-block and is mapped to more than one T2-frame. Figure 18(b) shows an example in which one Interleaving Frame is mapped to two T2-frames, and  $FRAME\_INTERVAL(I_{JUMP})=2$ . This gives greater time diversity for low data-rate services. This option is signalled in the L1-signalling by  $TIME\_IL\_TYPE='1'$ .
- 3) Each Interleaving Frame is mapped directly to one T2-frame and the Interleaving Frame is divided into several TI-blocks as shown in figure 18(c). Each of the TI-blocks may use up to the full TI memory, thus increasing the maximum bit-rate for a PLP. This option is signalled in the L1-signalling by  $TIME\_IL\_TYPE='0'$ .

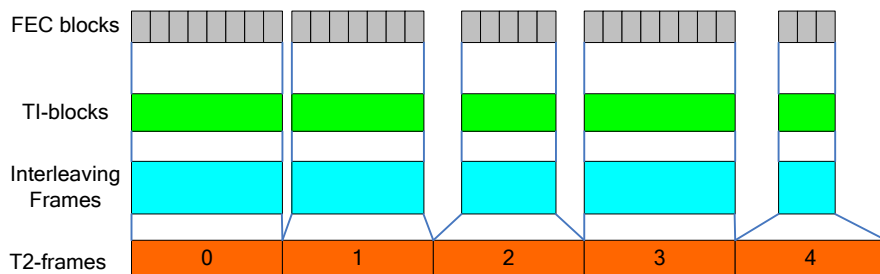


Figure 18(a): Time interleaving for  $P_1=1$ ,  $I_{JUMP}=1$ ,  $N_{TI}=1$

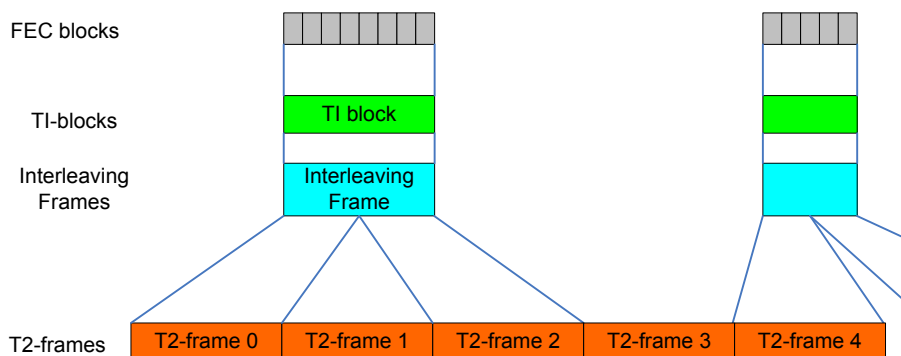


Figure 18(b): Time interleaving for  $P_1=2$ ,  $I_{JUMP}=2$ ,  $N_{TI}=1$

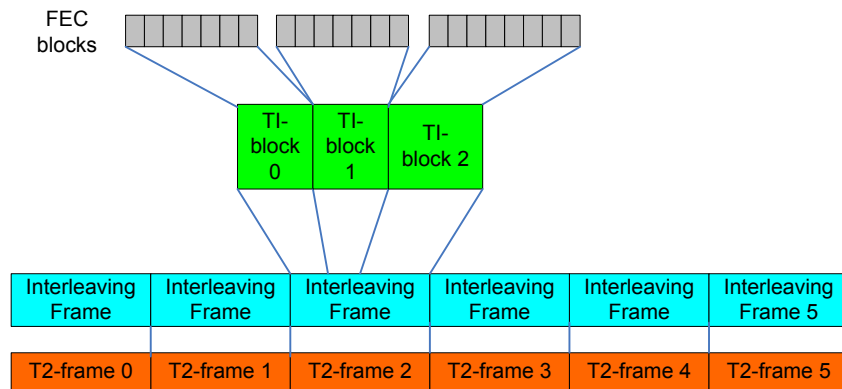


Figure 18(c): Time interleaving for  $P_1=1$ ,  $I_{\text{JUMP}}=1$ ,  $N_{\text{TI}}=3$

### 6.5.1 Mapping of Interleaving Frames onto one or more T2-frames

Each Interleaving Frame is either mapped directly onto one T2-frame or spread out over several T2-frames. The number of T2-frames in one Interleaving Frame,  $P_I$ , is signalled in the L1 configurable signalling by TIME\_IL\_LENGTH in conjunction with TIME\_IL\_TYPE.

The length of the time interleaving period  $T_P$  shall not exceed one super-frame. The time interleaving period is calculated as:

$$T_P = T_F \times P_I(i) \times I_{\text{JUMP}}(i),$$

where  $T_F$  is the T2-frame length in time (see clause 8.3.1) and  $I_{\text{JUMP}}(i)$  is the interval of T2-frames for PLP  $i$ , e.g. if the PLP occurs in every third T2-frame  $I_{\text{JUMP}}(i)=3$  (see clause 8.2).  $P_I(i)$  is the value of  $P_I$  for PLP  $i$ .

NOTE: There will be an integer number of FEC blocks in an Interleaving Frame, but the number of FEC blocks per T2-frame need not be an integer if the Interleaving Frame extends over several T2-frames.

There shall be an integer number of Interleaving Frames in a super-frame so that:

$$N_{T2} / (P_I \times I_{\text{JUMP}}) = \text{integer number of Interleaving Frames per super-frame},$$

where  $N_{T2}$  is the number of T2-frames in a super-frame.

EXAMPLE: The super-frame length of a T2 system is  $N_{T2}=20$ . The system carries among others the following PLPs: PLP1 with interleaving length  $P_I(1)=1$  frame occurring in every T2-frame:  $I_{\text{JUMP}}(1)=1$ ; PLP2 with interleaving length  $P_I(2)=2$  frames occurring in every second T2-frame:  $I_{\text{JUMP}}(2)=2$ ; and PLP3 with interleaving length  $P_I(3)=4$  frames occurring in every fifth T2-frame:  $I_{\text{JUMP}}(3)=5$ . The number of Interleaving Frames per super-frame is  $20 / (1 \times 1) = 20$  Interleaving Frames for PLP1,  $20 / (2 \times 2) = 5$  Interleaving Frames for PLP2 and  $20 / (4 \times 5) = 1$  Interleaving Frames for PLP3.

### 6.5.2 Division of Interleaving frames into Time Interleaving Blocks

The time interleaver interleaves cells over one TI-block, which contains a dynamically variable integer number of FEC blocks.

In one Interleaving Frame there may be one or more TI-blocks. The number of TI-blocks in an Interleaving Frame, denoted by  $N_{\text{TI}}$ , shall be an integer and is signalled in the L1 configurable signalling by TIME\_IL\_LENGTH in conjunction with TIME\_IL\_TYPE.

NOTE: If an Interleaving Frame extends over multiple T2-frames, then  $N_{\text{TI}}$  will be 1, i.e. one Interleaving Frame will contain exactly one TI-block.

The number of FEC blocks in TI-block index 's' of Interleaving Frame 'n' is denoted by  $N_{FEC\_TI}(n,s)$ , where  $0 \leq s < N_{TI}$ .

If  $N_{TI} = 1$ , then there will be only one TI-block, with index  $s=0$ , per Interleaving Frame and  $N_{FEC\_TI}(n,s)$  shall be equal to the number of FEC blocks in the Interleaving Frame,  $N_{BLOCKS\_IF}(n)$ .

If  $N_{TI} > 1$ , then the value of  $N_{FEC\_TI}(n,s)$  for each TI-block (index  $s$ ) within the Interleaving Frame (index  $n$ ) shall be calculated as follows:

$$N_{FEC\_TI}(n,s) = \begin{cases} \left\lfloor \frac{N_{BLOCKS\_IF}(n)}{N_{TI}} \right\rfloor & s < N_{TI} - [N_{BLOCKS\_IF}(n) \bmod N_{TI}] \\ \left\lfloor \frac{N_{BLOCKS\_IF}(n)}{N_{TI}} \right\rfloor + 1 & s \geq N_{TI} - [N_{BLOCKS\_IF}(n) \bmod N_{TI}] \end{cases}$$

This ensures that the values of  $N_{FEC\_TI}(n,s)$  for the TI-blocks within an Interleaving Frame differ by at most one FEC block and that the smaller TI-blocks come first.

$N_{FEC\_TI}(n,s)$  may vary in time from a minimum value of 0 to a maximum value  $N_{FEC\_TI\_MAX}$ .  $N_{FEC\_TI\_MAX}$  may be determined from  $N_{BLOCKS\_IF\_MAX}$  (see clause 6.5) by the following formula:

$$N_{FEC\_TI\_MAX} = \left\lceil \frac{N_{BLOCKS\_IF\_MAX}}{N_{TI}} \right\rceil$$

The maximum number of TI memory cells per PLP shall be  $M_{TI} = 2^{19} + 2^{15}$ , but note that this memory shall be shared between the data PLP and its associated common PLP (if any). Therefore, for PLPs without an associated common PLP,  $N_{BLOCKS\_IF\_MAX}$  and  $N_{TI}$  shall be chosen such that:

$$N_{FEC\_TI\_MAX} \times N_{CELLS} \leq M_{TI}$$

where  $N_{CELLS}$  is the number of cells per FEC block and is given in table 17 for the various constellations and FEC lengths.

NOTE: The value of  $M_{TI}$  is reduced to  $2^{18}$  for T2-Lite – see annex I.

For PLPs having an associated common PLP, the  $M_{TI}$  TI cells shall be divided statically between the data PLP and the common PLP, such that for any one data PLP from a group with an associated common PLP:

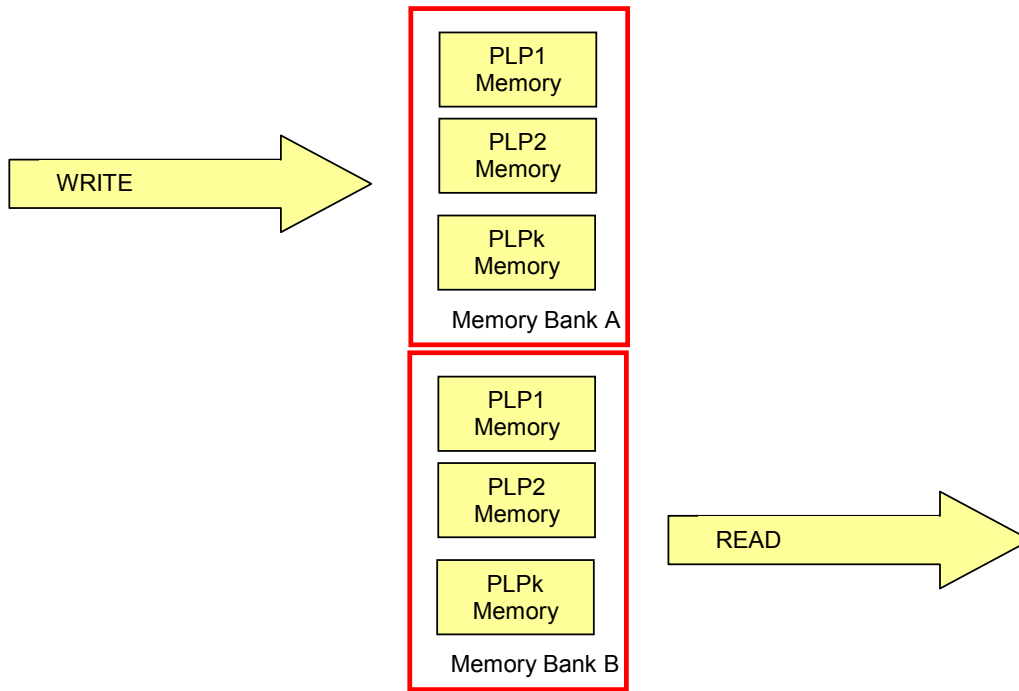
$$N_{FEC\_TI\_MAX}(\text{data PLP}) \times N_{CELLS}(\text{data PLP}) + N_{FEC\_TI\_MAX}(\text{common PLP}) \times N_{CELLS}(\text{common PLP}) \leq M_{TI}$$

The FEC blocks at the input shall be assigned to TI-blocks in increasing order of  $s$ . Each TI-block shall be interleaved as described in clause 6.5.3 and then the cells of each interleaved TI-block shall be concatenated together to form the output Interleaving Frame.

### 6.5.3 Interleaving of each TI-block

The TI shall store in the TI memories (one per PLP) the cells ( $d_{n,s,0,0}, d_{n,s,0,1}, \dots, d_{n,s,0,N_{cells}-1}, d_{n,s,1,0}, d_{n,s,1,1}, \dots, d_{n,s,1,N_{cells}-1}, \dots, d_{n,s,N_{FEC\_TI}(n,s)-1,0}, d_{n,s,N_{FEC\_TI}(n,s)-1,1}, \dots, d_{n,s,N_{FEC\_TI}(n,s)-1,N_{cells}-1}$ ) of the  $N_{FEC\_TI}(n,s)$  FEC blocks from the output of the cell interleaver, where  $d_{n,s,r,q}$  is the output cell  $d_{r,q}$  from the cell interleaver belonging to the current TI-block  $s$  of the current Interleaving Frame  $n$ .

Typically, the time interleaver will also act as a buffer for PLP data prior to the process of frame building (see clause 8). This can be achieved by means of two memory banks for each PLP. The first TI-block is written to the first bank. The second TI-block is written to the second bank whilst the first bank is being read from and so on, see figure 19.



**Figure 19: Example of operation of time interleaver memory banks**

The TI shall be a row-column block interleaver: the number of rows  $N_r$  in the interleaver is equal to the number of cells in the FEC block ( $N_{cells}$ ) divided by 5, and the number of columns  $N_c = 5 \times N_{FEC}(n,s)$ . Hence the number of columns filled will vary TI-block by TI-block depending on its cell-rate. The parameters of the interleaver are defined in table 17.

**Table 17: Parameters for time interleaver**

LDPC block length ( $N_{ldpc}$ )	Modulation mode	Number of cells per LDPC block ( $N_{CELLS}$ )	Number of rows $N_r$
64 800	256-QAM	8 100	1 620
	64-QAM	10 800	2 160
	16-QAM	16 200	3 240
	QPSK	32 400	6 480
16 200	256-QAM	2 025	405
	64-QAM	2 700	540
	16-QAM	4 050	810
	QPSK	8 100	1 620

A graphical representation of the time interleaver is shown in figure 20. The first FEC block is written column-wise into the first 5 columns of the time interleaver, the second FEC block is written column-wise into the next 5 columns and so on. The cells are read out row-wise.



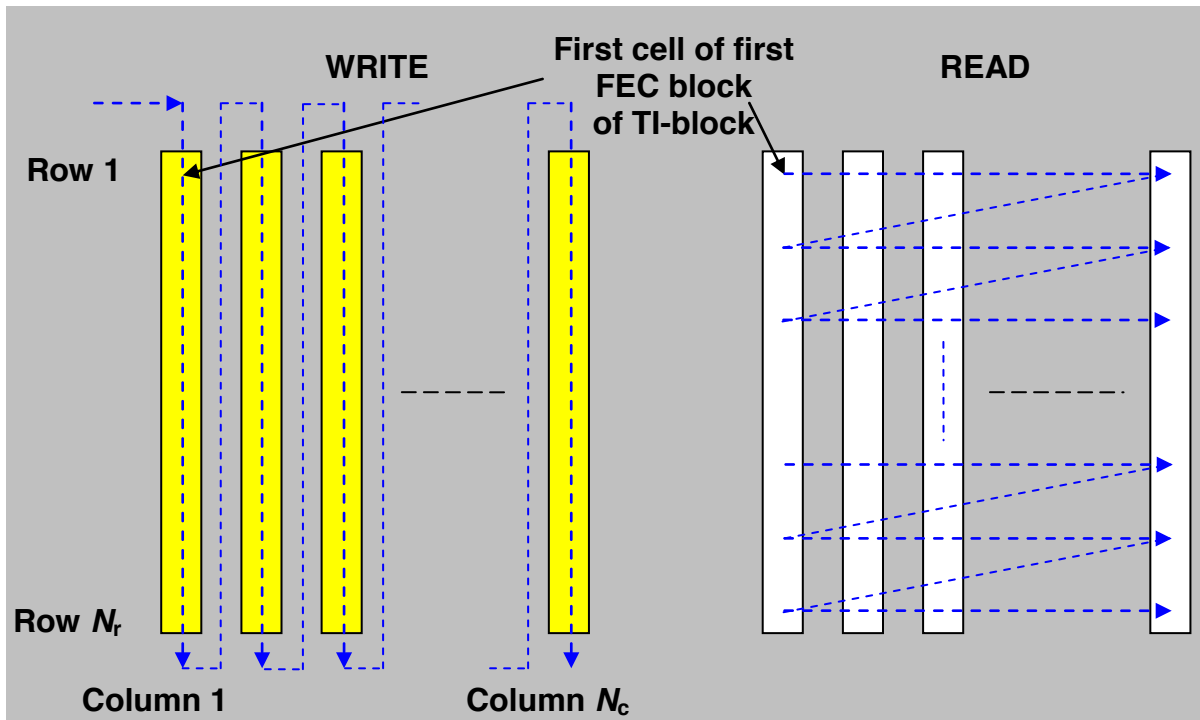


Figure 20: Time interleaver

#### 6.5.4 Using the three Time Interleaving options with sub-slicing

In order to allow the maximum flexibility to select TI characteristics, the Interleaving Frames at the output of the time interleaver may be split into multiple sub-slices, as described in clause 8.3.6.3.3.

The case where sub-slicing is used together with time-interleaving option (1) (where  $P_I=1$  and  $N_{TI}=1$  as defined above) is shown in figure 21, where the output from the TI-block is split into  $N_{\text{subslices}}$  sub-slices.

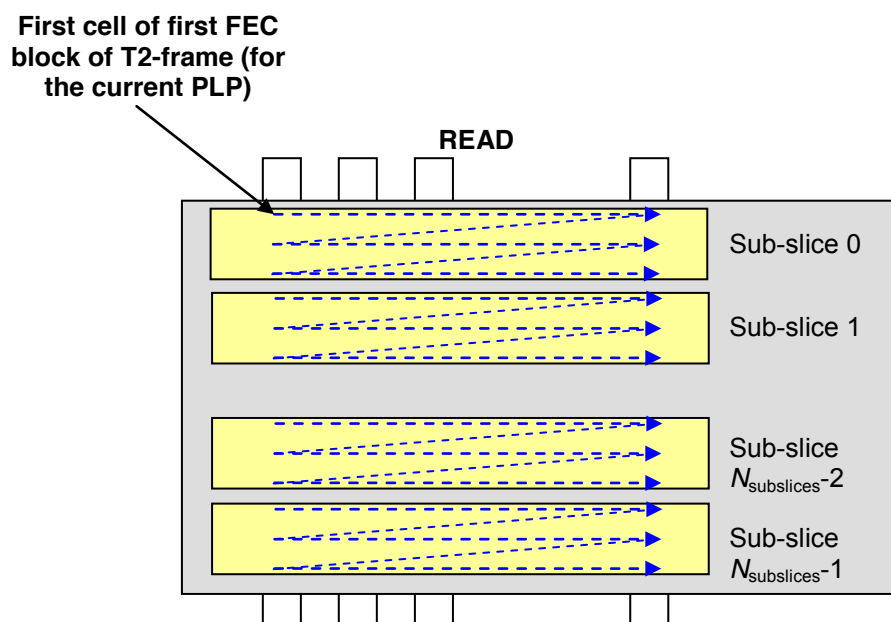
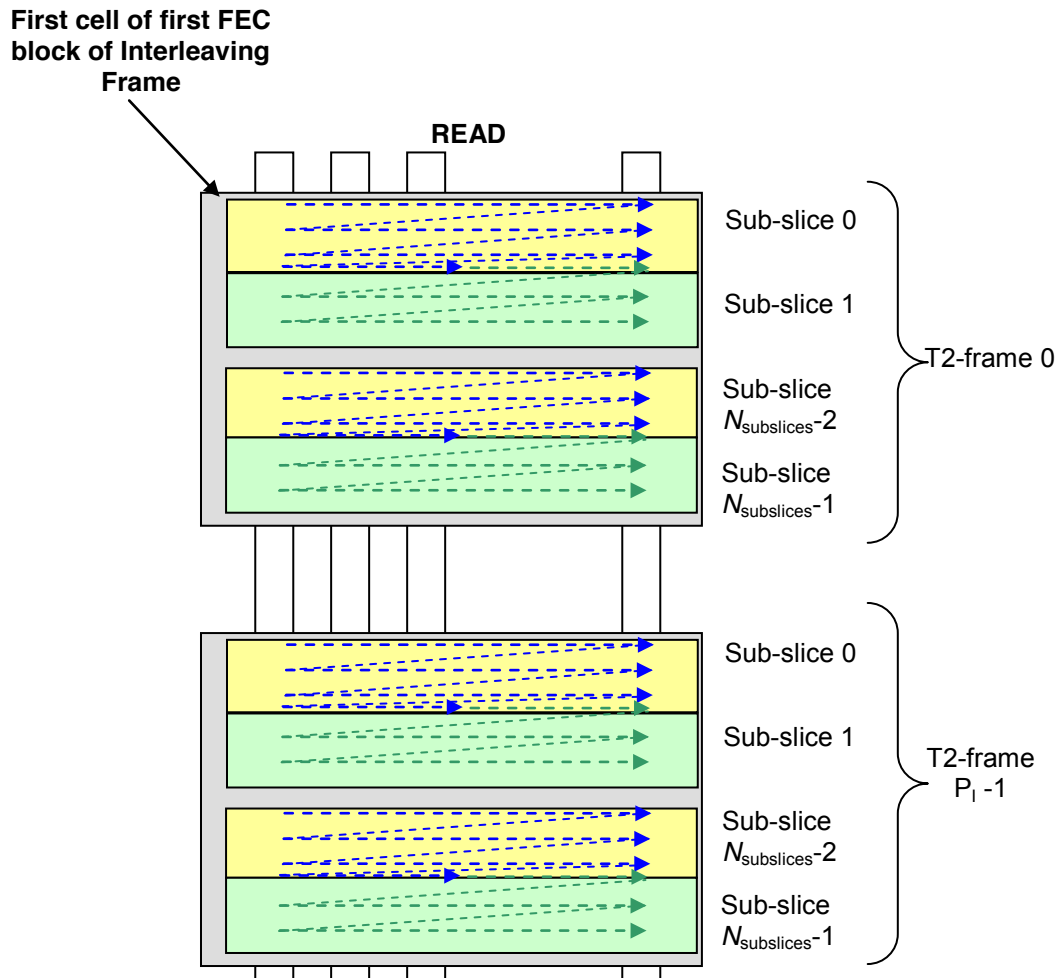


Figure 21: An example showing the output from a single TI-block, when interleaving over an integer number of T2-frames for a single RF channel

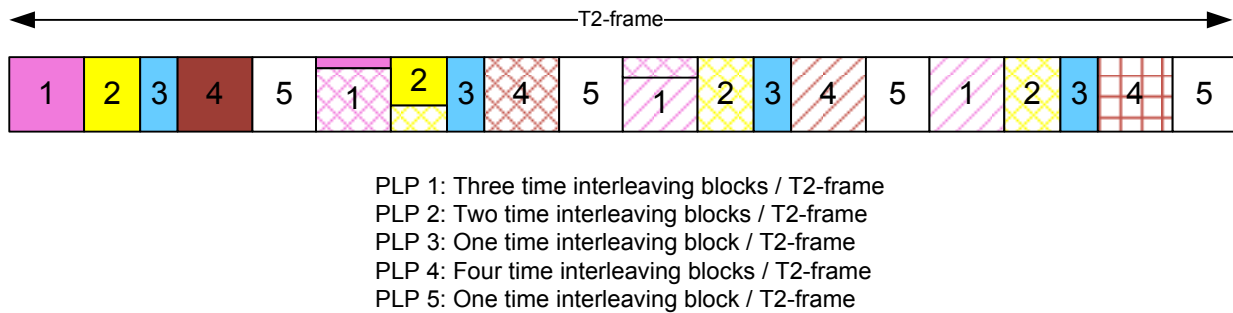
Sub-slicing may also be used together with time-interleaving option (2), where the output Interleaving Frame is mapped to more than one T2-frame as described in clause 6.5.1. This is similar to case (1), except that the Interleaving Frame is split into a total of  $N_{\text{subslices}} \times P_1$  sub-slices, as shown in figure 22.



**Figure 22: The output from a single TI-block, split into  $N_{\text{subslices}}$  sub-slices in each of  $P_1$  T2-frames**

Finally, sub-slicing may be used in combination with time interleaving option (3), where the Interleaving Frame is divided into multiple TI-blocks. The TI-blocks within the Interleaving Frame may be of different sizes, as described in clause 6.5.2, and the number of sub-slices need not have any particular relationship to the number  $N_{\text{TI}}$  of TI-blocks in the Interleaving Frame. Therefore, the sub-slices will not necessarily contain a whole number of rows from the time interleaver, and furthermore a sub-slice can contain cells from more than one TI-block.

**EXAMPLE 1:** In figure 23 the data PLPs of type 2 are transmitted in four sub-slices and one Interleaving Frame is mapped to one T2-frame for all PLPs. PLP1 has three TI-blocks, PLP2 has two TI-blocks and PLP4 has four TI-blocks in the Interleaving Frame; the others have one TI-block. PLP1 and PLP2 contain different numbers of FEC blocks in each TI-block of the Interleaving Frame. Some subslices for PLP1 and PLP2 contain cells from different TI-blocks.



**Figure 23: PLPs with different interleaving periods**

**EXAMPLE 2:** A PLP is interleaved using multiple TI-blocks per Interleaving Frame, so that one T2-frame contains two TI-blocks. The scheduler counts 23 received FEC blocks during a frame (PLP\_NUM\_BLOCKS = 23 in L1-post signalling). These are divided into two TI-blocks so that the first TI-block is interleaving over 11 FEC blocks and the second TI-block is interleaving over 12 FEC blocks, following the rule of interleaving over the smaller TI-block first. The number of sub-slices per T2-frame for type 2 data PLPs is 240. The first TI-block is then carried in sub-slices 1 to 115, the latter in sub-slices 115 to 240, with sub-slice 115 containing cells from both TI-blocks.

Whichever time interleaving option is used, all sub-slices of a PLP in a T2-frame shall contain an equal number of cells. This condition will automatically be satisfied because  $P_1$  and  $N_{\text{sub-slices}}$  shall be chosen in order to satisfy a more restrictive condition as described in clause 8.3.6.3.3. For Time-Frequency Slicing using multiple RF channels a different condition applies: see annex E.

### 6.5.5 PLPs for which Time Interleaving is not used

If time interleaving is not used (i.e. TIME\_IL\_LENGTH=0), the output of the time interleaver shall consist of the cells presented at the input in the same order and without modification. In this case, when the term Interleaving Frame is used elsewhere in the present document, it shall be taken to mean T2-frame.

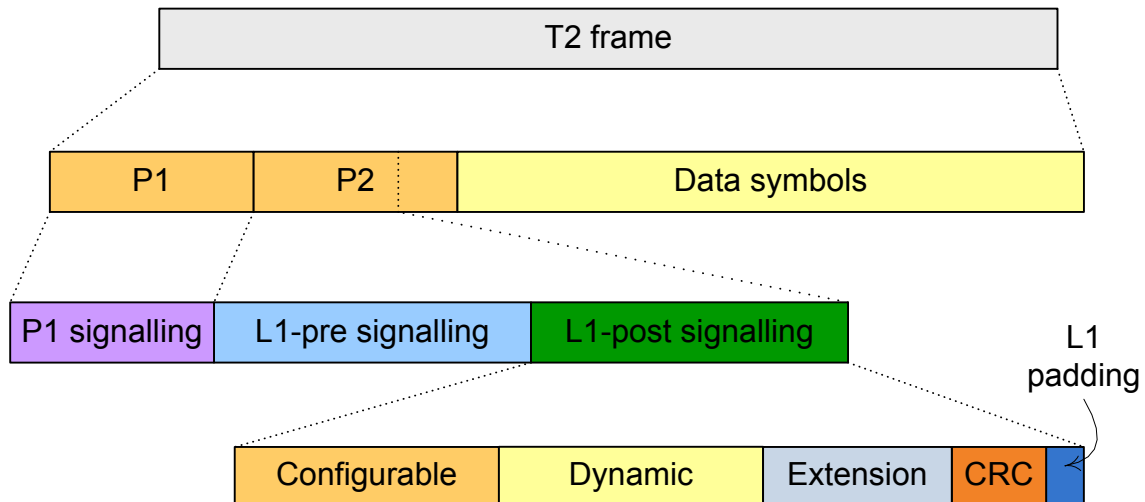
**NOTE:** TIME\_IL\_LENGTH may only be set to '0' when NUM\_PLP is set to '1' (see clause 7.2.3.1).

As explained above, the time interleaver will typically act as a buffer for PLP data and therefore the output may be delayed by a varying amount with respect to the input even when time interleaving is not used. In this case, a compensating delay for the dynamic configuration information from the scheduler will still be required, as shown in figure 2(e).

## 7 Generation, coding and modulation of Layer 1 signalling

### 7.1 Introduction

This clause describes the layer 1 (L1) signalling. The L1 signalling provides the receiver with a means to access physical layer pipes within the T2-frames. Figure 24 illustrates the L1 signalling structure, which is split into three main sections: the P1 signalling, the L1-pre signalling and L1-post signalling. The purpose of the P1 signalling, which is carried by the P1 symbol, is to indicate the transmission type and basic transmission parameters. The remaining signalling is carried by the P2 symbol(s), which may also carry data. The L1-pre signalling enables the reception and decoding of the L1-post signalling, which in turn conveys the parameters needed by the receiver to access the physical layer pipes. The L1-post signalling is further split into two main parts: configurable and dynamic, and these may be followed by an optional extension field. The L1-post finishes with a CRC and padding (if necessary). For more details of the frame structure, see clause 8.



**Figure 24: The L1 signalling structure**

Throughout the present document, some of the signalling fields or parts of fields are indicated as "reserved for future use" - the meaning of such fields are not defined by the present document and shall be ignored by receivers. Where the value of such a field, or part of the field, is not otherwise defined, it shall be set to '0'. Fields, or parts of fields, whose value is not explicitly defined by the present document shall be treated as though they were defined to be reserved for future use.

In clause 7.2 only, some reserved fields and part of the L1 extension field, if any, are designated as "sometimes used for bias balancing". In version 1.1.1 of this document, these fields were reserved for future use and were set to '0'. If the T2\_VERSION field is set to a value greater than '0000', the bits of the bias balancing fields and the relevant part of the L1 extension field may be set according to clause 7.2.3.7.

## 7.2 L1 signalling data

All L1 signalling data, except for the dynamic L1-post signalling, shall remain unchanged for the entire duration of one super-frame. Hence any changes implemented to the current configuration (i.e. the contents of the L1-pre signalling or the configurable part of the L1-post signalling) shall be always done within the border of two super-frames.

**NOTE:** For completeness, all of the signalling for both T2-base and T2-Lite profiles is included in clause 7. Unless otherwise stated, all signalling applies to both T2-base and T2-Lite profiles.

### 7.2.1 P1 Signalling data

The P1 symbol has the capability to convey 7 bits for signalling. Since the preamble (both P1 and P2 symbols) may have different formats, the main use of the P1 signalling is to identify the preamble itself. The information it carries is of two types: the first type (associated to the S1 bits of the P1) is needed to distinguish the preamble format (and, hence, the frame type); the second type helps the receiver to rapidly characterize the basic TX parameters.

- The S1 field: Preamble Format:
  - The preamble format is carried in the S1 field of the P1 symbol. It identifies the format of the P2 symbol(s) that take part of the preamble.

**Table 18: S1 Field**

S1	Preamble Format / P2 Type	Description
000	T2_SISO	The preamble is a T2-base preamble and the P2 part is transmitted in its SISO format
001	T2_MISO	The preamble is a T2-base preamble and the P2 part is transmitted in its MISO format
010	Non-T2	See table 19(b)
011	T2_LITE_SISO	The preamble is a preamble of a T2-Lite signal (see annex I). The P2 part is transmitted in its SISO format
100	T2_LITE_MISO	The preamble is a preamble of a T2-Lite signal (see annex I). The P2 part is transmitted in its MISO format
101 110 111	Reserved for future use	These combinations may be used for future systems, including a system containing both T2-frames and FEF parts, as well as future systems not defined in the present document

- The S2 field 1: Complementary information:
  - The first 3 bits of the S2 field are referred to as S2 field 1. When the preamble format is of the type T2\_SISO, T2\_MISO, T2-LITE\_SISO or T2-LITE\_MISO, S2 field 1 indicates the FFT size and gives partial information about the guard interval for the remaining symbols in the T2-frame, as described in table 19(a). When the preamble is of the type "Non-T2", S2 field 1 is described by table 19(b). When the S1 field is equal to one of the values reserved for future use, the value of the S2 field 1 shall also be reserved for future use.

**Table 19(a): S2 Field 1 (for T2 preamble types, S1=00X, 011 and 100)**

S1	S2	FFT/GI size (T2-base profile)	FFT/GI size (T2-Lite profile)	Description
00X	000X	FFT Size: 2K - any allowed guard interval	FFT Size: 2K – any allowed guard interval	Indicates the FFT size and guard interval of the symbols in the T2-frame
00X	001X	FFT Size: 8K - guard intervals 1/32; 1/16; 1/8 or 1/4	FFT Size: 8K – guard intervals 1/32; 1/16; 1/8 or 1/4	
00X	010X	FFT Size: 4K - any allowed guard interval	FFT Size: 4K – any allowed guard interval	
00X	011X	FFT Size: 1K - any allowed guard interval	FFT Size: 16K – guard intervals 1/128; 19/256 or 19/128	
00X	100X	FFT Size: 16K - any allowed guard interval	FFT Size: 16K – guard intervals 1/32; 1/16; 1/8 or 1/4	
00X	101X	FFT Size: 32K - guard intervals 1/32; 1/16; or 1/8	Reserved for future use	
00X	110X	FFT Size: 8K - guard intervals 1/128; 19/256 or 19/128	FFT Size: 8K – guard intervals 1/128; 19/256 or 19/128	
00X	111X	FFT Size: 32K - guard intervals 1/128; 19/256 or 19/128	Reserved for future use	

**Table 19(b): S2 Field 1 (for Non-T2 preambles, S1=010)**

S1	S2 field 1	S2 field 2	Meaning	Description
010	000	X	Undefined FEF part	The preamble is the preamble of a FEF part, but the contents of the remainder of the FEF part are not specified by the present document - it may be used in any way for professional applications and is not intended for consumer receivers
010	001 - 111	X	Reserved for future use	-

- The S2 field 2: 'Mixed' bit:
  - This bit indicates whether the preambles are all of the same type or not. The bit is valid for all values of S1 and S2 field 1. The meaning of this bit is given in table 20.

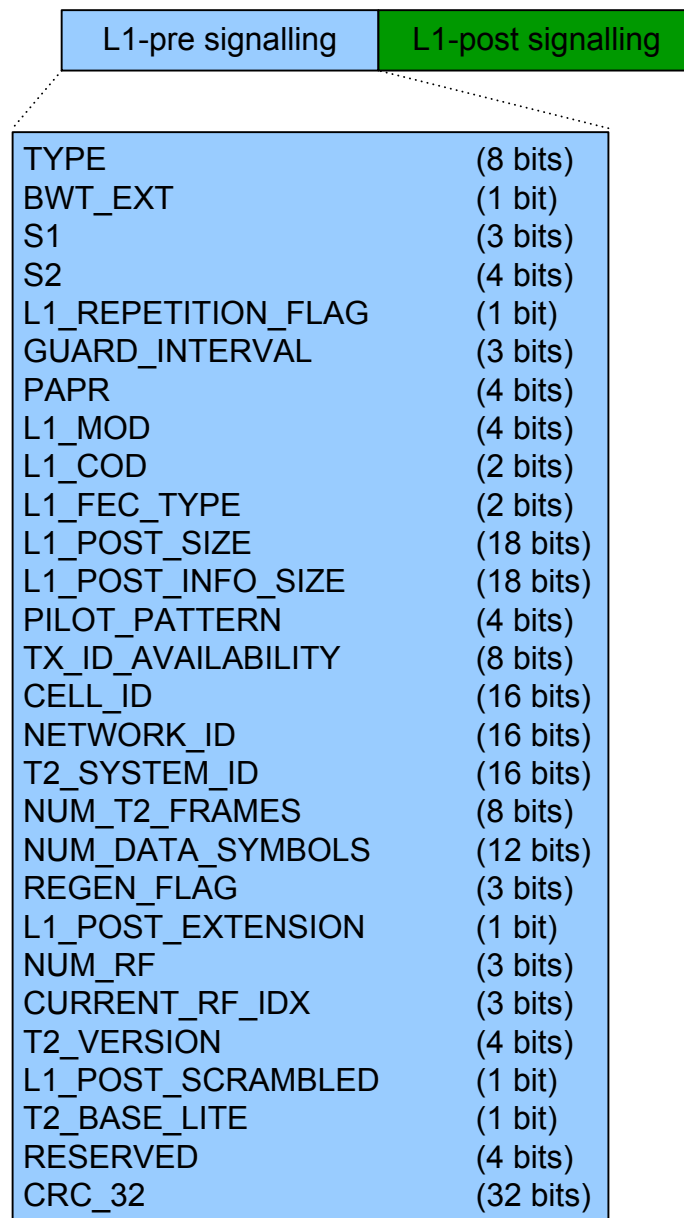
**Table 20: S2 field 2**

S1	S2 field 1	S2 field 2	Meaning	Description
xxx	xxx	0	Not mixed	All preambles in the current transmission are of the same type as this preamble.
xxx	xxx	1	Mixed	Preambles of different types are transmitted

The modulation and construction of the P1 symbol is described in clause 9.8.

## 7.2.2 L1-Pre Signalling data

Figure 25 illustrates the signalling fields of the L1-pre signalling, followed by the detailed definition of each field.



**Figure 25: The signalling fields of L1-pre signalling**

**TYPE:** This 8-bit field indicates the types of the Tx input streams carried within the current T2 super-frame. The mapping of different types is given in table 21.

**Table 21: The mapping of Tx input stream types**

Value	Type
0x00	Transport Stream (TS) [i.1] only
0x01	Generic Stream (GSE [i.2] and/or GFPS and/or GCS) but not TS
0x02	Both TS and Generic Stream (i.e. TS and at least one of GSE, GFPS, GCS)
0x03 to 0xFF	Reserved for future use

**BWT\_EXT:** This 1-bit field indicates whether the extended carrier mode is used in the case of 8K, 16K and 32K FFT sizes. When this field is set to '1', the extended carrier mode is used. If this field is set to '0', the normal carrier mode is used. See clause 9.5.

**S1:** This 3-bit field has the same value as in the P1 signalling.

**S2:** This 4-bit field has the same value as in the P1 signalling.

**L1\_REPETITION\_FLAG:** This 1-bit flag indicates whether the dynamic L1-post signalling is provided also for the next frame. If this field is set to value '1', the dynamic signalling shall be also provided for the next frame within this frame. When this field is set to value '0', dynamic signalling shall not be provided for the next frame within this frame. If dynamic signalling is provided for the next frame within this frame, it shall follow immediately after the dynamic signalling of the current frame, see clause 7.2.3.3.

**GUARD\_INTERVAL:** This 3-bit field indicates the guard interval of the current super-frame, according to table 22.

**Table 22: Signalling format for the guard interval**

Value	Guard interval fraction
000	1/32
001	1/16
010	1/8
011	1/4
100	1/128
101	19/128
110	19/256
111	Reserved for future use

**PAPR:** This 4-bit field describes what kind of PAPR reduction is used, if any. The values shall be signalled according to table 23.

**Table 23a: Signalling format for PAPR reduction (when T2\_VERSION = '0000')**

Value	PAPR reduction
0000	No PAPR reduction is used
0001	ACE-PAPR only is used
0010	TR-PAPR only is used
0011	Both ACE and TR are used
0100 to 1111	Reserved for future use

**Table 23b: Signalling format for PAPR reduction (when T2\_VERSION > '0000')**

Value	PAPR reduction
0000	L1-ACE is used and TR is used on P2 symbols only
0001	L1-ACE and ACE only are used
0010	L1-ACE and TR only are used
0011	L1-ACE, ACE and TR are used
0100 to 1111	Reserved for future use
NOTE: The term ACE refers to the algorithm as defined in clause 9.6.1 and the term L1-ACE refers to the algorithm defined in clause 7.3.3.3. The effect of L1-ACE may be turned off by setting the parameter $C_{L1\_ACE\_MAX}$ to a value of 0.	

**L1\_MOD:** This 4-bit field indicates the constellation of the L1-post signalling data block. The constellation values shall be signalled according to table 24.

**Table 24: Signalling format for the L1-post constellations**

Value	constellation
0000	BPSK
0001	QPSK
0010	16-QAM
0011	64-QAM
0100 to 1111	Reserved for future use

**L1\_COD:** This 2-bit field describes the coding of the L1-post signalling data block. The coding values shall be signalled according to table 25.

**Table 25: Signalling format for the L1-post code rates**

Value	Code rate
00	1/2
01 to 11	Reserved for future use

**L1\_FEC\_TYPE:** This 2-bit field indicates the type of the L1 FEC used for the L1-post signalling data block. The L1\_FEC\_TYPE shall be signalled according to table 26.

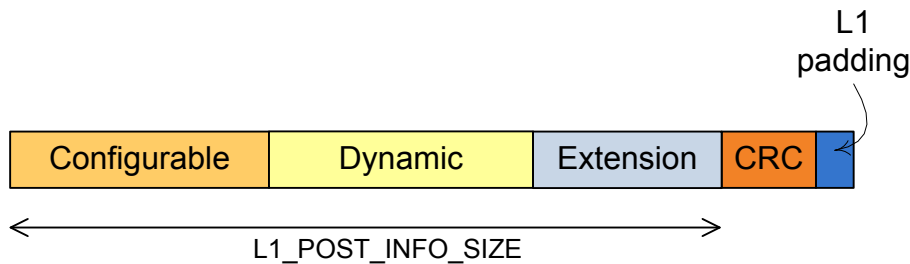
**Table 26: Signalling format for the L1-post FEC type**

Value	L1 FEC type
00	LDPC 16K
01 to 11	Reserved for future use

**L1\_POST\_SIZE:** This 18-bit field indicates the size of the coded and modulated L1-post signalling data block, in OFDM cells.

**L1\_POST\_INFO\_SIZE:** This 18-bit field indicates the size of the information part of the L1-post signalling data block, in bits, including the extension field, if present, but excluding the CRC. The value of  $K_{\text{post\_ex\_pad}}$  (see clause 7.3.1.2) may be calculated by adding 32 (the length of the CRC) to L1\_POST\_INFO\_SIZE. This is shown in figure 26.





**Figure 26: The size indicated by the L1\_POST\_INFO\_SIZE field**

**PILOT\_PATTERN:** This 4-bit field indicates the scattered pilot pattern used for the data OFDM symbols. Each pilot pattern is defined by the  $D_x$  and  $D_y$  spacing parameters (see clause 9.2.3). The used pilot pattern is signalled according to table 27.

**Table 27: Signalling format for the pilot pattern**

Value	Pilot pattern type
0000	PP1
0001	PP2
0010	PP3
0011	PP4
0100	PP5
0101	PP6
0110	PP7
0111	PP8
1000 to 1111	Reserved for future use

**TX\_ID\_AVAILABILITY:** This 8-bit field is used to signal the availability of transmitter identification signals within the current geographic cell. When no transmitter identification signals are used this field is set to 0x000. All other bit combinations are reserved for future use.

**CELL\_ID:** This is a 16-bit field which uniquely identifies a geographic cell in a DVB-T2 network. A DVB-T2 cell coverage area may consist of one or more frequencies, depending on the number of frequencies used per T2 system. If the provision of the CELL\_ID is not foreseen, this field shall be set to '0'.

**NETWORK\_ID:** This is a 16-bit field which uniquely identifies the current DVB network.

**T2\_SYSTEM\_ID:** This 16-bit field uniquely identifies a T2 system within the DVB network (identified by NETWORK\_ID).

**NUM\_T2\_FRAMES:** This 8-bit field indicates  $N_{T2}$ , the number of T2-frames per super-frame. The minimum value of NUM\_T2\_FRAMES shall be 2.

**NUM\_DATA\_SYMBOLS:** This 12-bit field indicates  $L_{data} = L_F - N_{P2}$ , the number of data OFDM symbols per T2-frame, excluding P1 and P2. The minimum value of NUM\_DATA\_SYMBOLS is defined in clause 8.3.1.

**REGEN\_FLAG:** This 3-bit field indicates how many times the DVB-T2 signal has been re-generated. Value '000' indicates that no regeneration has been done. Each time the DVB-T2 signal is regenerated this field is increased by one.

**L1\_POST\_EXTENSION:** This 1-bit field indicates the presence of the L1-post extension field (see clause 7.2.3.4). When the extension field is present in the L1-post, this bit shall be set to a 1, otherwise it shall be set to a 0.

**NUM\_RF:** This 3-bit field indicates  $N_{RF}$ , the number of frequencies in the current T2 system. The frequencies are listed within the configurable parameters of the L1-post signalling.

**CURRENT\_RF\_IDX:** If the TFS mode is supported, this 3-bit field indicates the index of the current RF channel within its TFS structure, between 0 and NUM\_RF-1. In case the TFS mode is not supported, this field is set to '0'.

**T2\_VERSION:** This 4-bit field indicates the latest version of the present document on which the transmitted signal is based. T2\_VERSION shall be signalled according to table 28:

**Table 28: Signalling format for the T2 version field**

Value	Specification version
0000	1.1.1
0001	1.2.1
0010	1.3.1
0011-1111	Reserved for future use

If T2\_VERSION is set to '0000', then all of the fields L1\_POST\_SCRAMBLED, T2\_BASE\_LITE, IN\_BAND\_B\_FLAG, PLP\_MODE, STATIC\_FLAG, STATIC\_PADDING\_FLAG and FEF\_LENGTH\_MSB shall also be set to 0.

If T2\_VERSION is set '0001', then the fields L1\_POST\_SCRAMBLED, T2\_BASE\_LITE, and FEF\_LENGTH\_MSB are reserved for future use and are sometimes used for bias balancing.

NOTE 1: A receiver can assume that higher versions of the L1-signalling can always be interpreted as though encoded according to lower versions.

**L1\_POST\_SCRAMBLED:** This 1-bit field indicates that the L1\_POST signalling is scrambled according to clause 7.3.2.1.

NOTE 2: This feature was not included in versions prior to 1.3.1 of the present document – therefore it should not be enabled in areas where the signal is expected to be demodulated by receivers built according to the earlier versions of the present document.

**T2\_BASE\_LITE:** This 1-bit T2-base field is used to indicate that the current T2-base profile signal is compatible with the T2-LITE profile i.e. it uses parameters consistent with all of the restrictions of annex I, except that it uses one of the S1 signalling types T2\_SISO or T2\_MISO (see table 18). For a T2-Lite profile signal, this bit is reserved for future use (but shall not be used for bias balancing).

NOTE 3: In version 1.2.1 of the present document the fields L1\_POST\_SCRAMBLED and T2\_BASE\_LITE were part of the following 'RESERVED' field, and may have been set by the bias balancing algorithm (see clause 7.2.3.7). Therefore, these bits can only be assumed to have the correct meaning if the T2\_VERSION field is set to '0010' or greater.

**RESERVED:** This 4-bit field is reserved for future use. It is sometimes used for bias balancing.

**CRC-32:** This 32-bit error detection code is applied to the entire L1-pre signalling. The CRC-32 code is defined in annex F.

## 7.2.3 L1-post signalling data

The L1-post signalling contains parameters which provide sufficient information for the receiver to decode the desired physical layer pipes. The L1-post signalling further consists of two types of parameters, configurable and dynamic, plus an optional extension field. The configurable parameters shall always remain the same for the duration of one super-frame, whilst the dynamic parameters provide information which is specific for the current T2-frame. The values of the dynamic parameters may change during the duration of one super-frame, while the size of each field shall remain the same.

### 7.2.3.1 Configurable L1-post signalling

Figure 27 illustrates the signalling fields of the configurable L1-post signalling, followed by the detailed definition of each field.

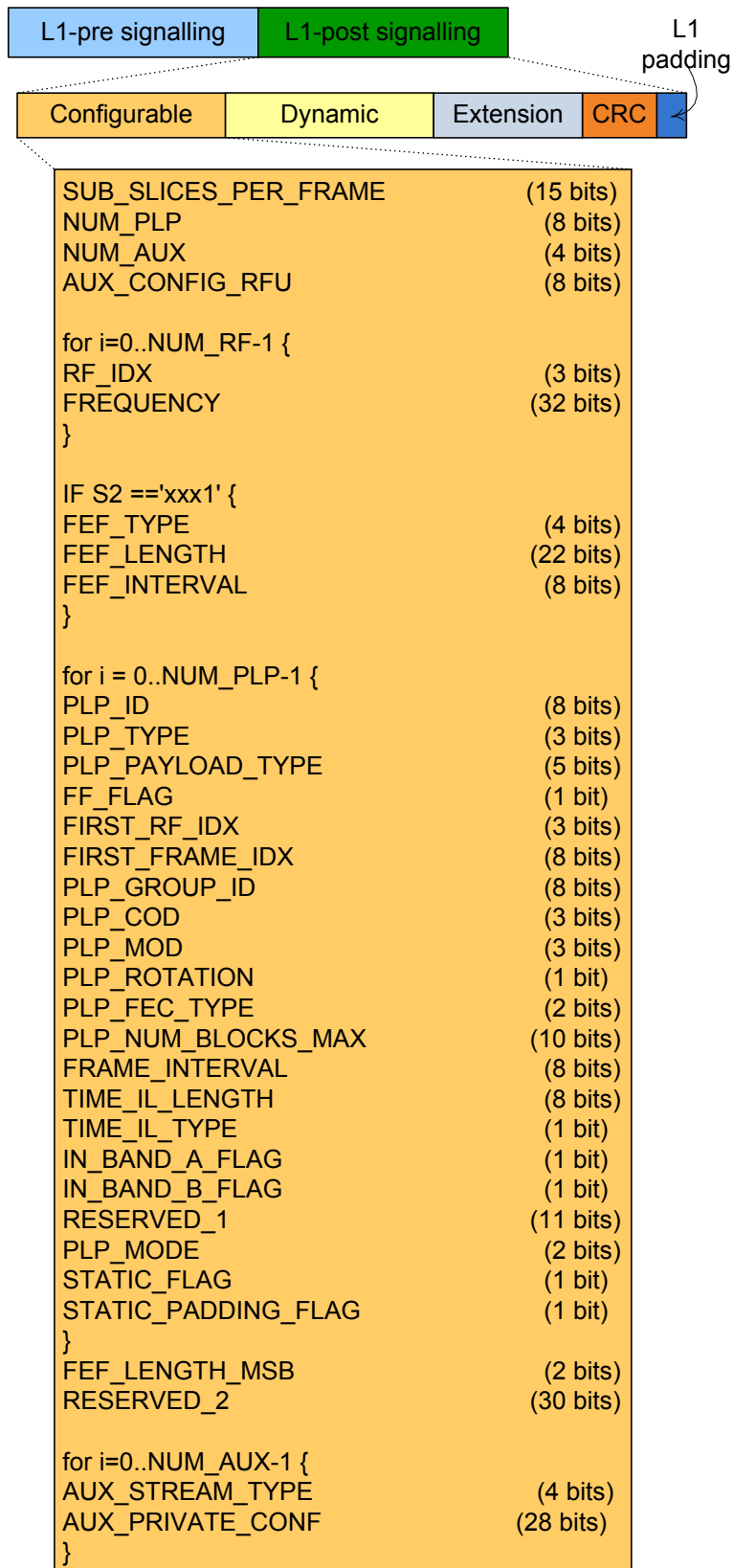


Figure 27: The signalling fields of configurable L1-post signalling

**SUB\_SLICES\_PER\_FRAME:** This 15-bit field indicates  $N_{\text{subslices\_total}}$ , the total number of sub-slices for the type 2 data PLPs across all RF channels in one T2-frame. When TFS is used, this is equal to,  $N_{\text{subslices}} \times N_{\text{RF}}$ , i.e. the number of sub-slices in each RF channel multiplied by the number of RF channels. When TFS is not used,  $N_{\text{subslices\_total}} = N_{\text{subslices}}$ . If there are no type 2 PLPs, this field shall be set to '1<sub>D</sub>'. Allowable values of this field are listed in annex L.

**NUM\_PLP:** This 8-bit field indicates the number of PLPs carried within the current super-frame. The minimum value of this field shall be '1'.

**NUM\_AUX:** This 4-bit field indicates the number of auxiliary streams. Zero means no auxiliary streams are used, and clause 8.3.7 shall be ignored.

**AUX\_CONFIG\_RFU:** This 8-bit field is reserved for future use.

The following fields appear in the frequency loop:

**RF\_IDX:** This 3-bit field indicates the index of each FREQUENCY listed within this loop. The RF\_IDX value is allocated a unique value between 0 and NUM\_RF-1. In case the TFS mode is supported, this field indicates the order of each frequency within the TFS configuration.

**FREQUENCY:** This 32-bit field indicates the centre frequency in Hz of the RF channel whose index is RF\_IDX. The order of the frequencies within the TFS configuration is indicated by the RF\_IDX. The value of FREQUENCY may be set to '0', meaning that the frequency is not known at the time of constructing the signal. If this field is set to 0, it shall not be interpreted as a frequency by a receiver.

The FREQUENCY fields can be used by a receiver to assist in finding the signals which form a part of the TFS system. Since the value will usually be set at a main transmitter but not modified at a transposer, the accuracy of this field shall not be relied upon.

The following fields appear only if the LSB of the S2 field is '1' (i.e. S2='xxx1'):

**FEF\_TYPE:** This 4-bit field shall indicate the type of the associated FEF part. The FEF types are signalled according to table 29.

**Table 29: Signalling format for the FEF type**

Value	FEF type
0000 to 1111	Reserved for future use

**FEF\_LENGTH:** This 22-bit field indicates the length of the associated FEF part as the number of elementary periods T (see clause 9.5), from the start of the P1 symbol of the FEF part to the start of the P1 symbol of the next T2-frame.

NOTE: The FEF\_LENGTH signalling is extended for T2-Lite by adding 2 MSBs using the FEF\_LENGTH\_MSB field – see annex I.

**FEF\_INTERVAL:** This 8-bit field indicates the number of T2-frames between two FEF parts (see figure 36). The T2-frame shall always be the first frame in a T2 super-frame which contains both FEF parts and T2-frames.

The following fields appear in the PLP loop:

**PLP\_ID:** This 8-bit field identifies uniquely a PLP within the T2 system.

**PLP\_TYPE:** This 3-bit field indicates the type of the associated PLP. PLP\_TYPE shall be signalled according to table 30.

**Table 30: Signalling format for the PLP\_TYPE field**

Value	Type
000	Common PLP
001	Data PLP Type 1
010	Data PLP Type 2
011 to 111	Reserved for future use

If value of the PLP\_TYPE field is one of the values reserved for future use, the total number of bits in the PLP loop shall be the same as for the other types, but the meanings of the fields other than PLP\_ID and PLP\_TYPE shall be reserved for future use and shall be ignored.

**PLP\_PAYLOAD\_TYPE:** This 5-bit field indicates the type of the payload data carried by the associated PLP. PLP\_PAYLOAD\_TYPE shall be signalled according to table 31. See clause 5.1.1 for more information.

**Table 31: Signalling format for the PLP\_PAYLOAD\_TYPE field**

Value	Payload type
00000	GFPS
00001	GCS
00010	GSE
00011	TS
00100 to 11111	Reserved for future use

**FF\_FLAG:** This flag is set to '1' if a PLP of type 1 in a TFS system occurs on the same RF channel in each T2-frame. This flag is set to '0' if inter-frame TFS is applied as described in annex E. When TFS is not used, or when TFS is used but PLP\_TYPE is not equal to '001', this field shall be set to 0 and has no meaning.

**FIRST\_RF\_IDX:** This 3-bit field indicates on which RF channel a type 1 data PLP occurs in the first frame of a super-frame in a TFS system. If FF\_FLAG = '1', the field indicates the RF channel the PLP occurs on in every T2-frame. When TFS is not used, or when TFS is used but PLP\_TYPE is not equal to '001', this field shall be set to 0 and has no meaning.

**FIRST\_FRAME\_IDX:** This 8-bit field indicates the IDX of the first frame of the super-frame in which the current PLP occurs. The value of FIRST\_FRAME\_IDX shall be less than the value of FRAME\_INTERVAL.

**PLP\_GROUP\_ID:** This 8-bit field identifies with which PLP group within the T2 system the current PLP is associated. This can be used by a receiver to link the data PLP to its associated common PLP, which will have the same PLP\_GROUP\_ID.

**PLP\_COD:** This 3-bit field indicates the code rate used by the associated PLP. The code rate shall be signalled according to table 32 for PLP\_FEC\_TYPE=00 and 01.

**Table 32: Signalling format for the code rates for PLP\_FEC\_TYPE=00 and 01**

Value	Code rate for T2-base profile	Code rate for T2-Lite profile (PLP_FEC_TYPE=00 only)
000	1/2	1/2
001	3/5	3/5
010	2/3	2/3
011	3/4	3/4
100	4/5	Reserved for future use
101	5/6	Reserved for future use
110	Reserved for future use	1/3
111	Reserved for future use	2/5

**PLP\_MOD:** This 3-bit field indicates the modulation used by the associated PLP. The modulation shall be signalled according to table 33.

**Table 33: Signalling format for the modulation**

Value	Modulation
000	QPSK
001	16-QAM
010	64-QAM
011	256-QAM
100 to 111	Reserved for future use

**PLP\_ROTATION:** This 1-bit flag indicates whether constellation rotation is in use or not by the associated PLP. When this field is set to the value '1', rotation is used. The value '0' indicates that the rotation is not used.

**PLP\_FEC\_TYPE:** This 2-bit field indicates the FEC type used by the associated PLP. The FEC types are signalled according to table 34.

**Table 34: Signalling format for the PLP FEC type**

Value	PLP FEC type for T2-base profile	PLP FEC type for T2-Lite profile
00	16K LDPC	16K LDPC
01	64K LDPC	Reserved for future use
10, 11	Reserved for future use	Reserved for future use

**PLP\_NUM\_BLOCKS\_MAX:** This 10-bit field indicates the maximum value of PLP\_NUM\_BLOCKS (see below) for this PLP.

**FRAME\_INTERVAL:** This 8-bit field indicates the T2-frame interval ( $I_{JUMP}$ ) within the super-frame for the associated PLP. For PLPs which do not appear in every frame of the super-frame, the value of this field shall equal the interval between successive frames. For example, if a PLP appears on frames 1, 4, 7 etc, this field would be set to '3'. For PLPs which appear in every frame, this field shall be set to '1'. For further details, see clause 8.2.

**TIME\_IL\_LENGTH:** The use of this 8-bit field is determined by the values set within the TIME\_IL\_TYPE -field as follows:

- If the TIME\_IL\_TYPE is set to the value '1', this field shall indicate  $P_I$ , the number of T2-frames to which each Interleaving Frame is mapped, and there shall be one TI-block per Interleaving Frame ( $N_{TI}=1$ ).
- If the TIME\_IL\_TYPE is set to the value '0', this field shall indicate  $N_{TI}$ , the number of TI-blocks per Interleaving Frame, and there shall be one Interleaving Frame per T2-frame ( $P_I=1$ ).

If there is one TI-block per Interleaving Frame and one T2-frame per Interleaving Frame, TIME\_IL\_LENGTH shall be set to the value '1' and TIME\_IL\_TYPE shall be set to '0'. If time interleaving is not used for the associated PLP, the TIME\_IL\_LENGTH-field shall be set to the value '0' and TIME\_IL\_TYPE shall be set to '0'. TIME\_IL\_LENGTH and TIME\_IL\_TYPE shall only both be set to '0' when NUM\_PLP is set to '1'.

**TIME\_IL\_TYPE:** This 1-bit field indicates the type of time-interleaving. A value of '0' indicates that one Interleaving Frame corresponds to one T2-frame and contains one or more TI-blocks. A value of '1' indicates that one Interleaving Frame is carried in more than one T2-frame and contains only one TI-block.

**IN-BAND\_A\_FLAG:** This 1-bit field indicates whether the current PLP carries in-band type A signalling information. When this field is set to the value '1' the associated PLP carries in-band type A signalling information. When set to the value '0', in-band type A signalling information is not carried.

**IN-BAND\_B\_FLAG:** This 1-bit field indicates whether the current PLP carries in-band type B signalling information. When this field is set to the value '1' the associated PLP carries in-band type B signalling information. When set to the value '0', in-band type B signalling information is not carried.

**RESERVED\_1:** This 11-bit field is reserved for future use. It is sometimes used for bias balancing.

**PLP\_MODE:** This 2-bit field indicates whether Normal Mode or High Efficiency Mode is used for the current PLP (see clause 5.1). The mode is signalled according to table 35.

**Table 35: Signalling format for the PLP\_MODE**

Value	PLP mode
00	Not specified
01	Normal Mode
10	High Efficiency Mode
11	Reserved for future use
NOTE: The value '00' shall only be used if T2_VERSION in the L1-pre signalling is set to '0000' (see clause 7.2.2). The value '00' is retained for backward compatibility with previous versions of the present document and indicates that the mode is signalled only in the CRC-8/MODE field of the BBHEADER.	

**STATIC\_FLAG:** This 1-bit field indicates whether the scheduling for the current PLP varies from T2-frame to T2-frame or remains static. When this field is set to '1', the following dynamic L1-post signalling fields shall change only at a super-frame boundary and only when a configuration change is indicated by the L1\_CHANGE\_COUNTER mechanism (see clause 7.2.3.2):

- SUBSLICE\_INTERVAL;
- TYPE\_A\_START;
- PLP\_START for the current PLP; and
- PLP\_NUM\_BLOCKS for the current PLP.

When the STATIC\_FLAG field is set to '0', the fields of the dynamic L1-post signalling may change at any time. For backwards compatibility with previous versions of the present document, this field may be set to '0' even when the scheduling is static, provided T2\_VERSION in the L1-pre signalling is set to '0000' (see clause 7.2.2).

NOTE 1: If the scheduling for the current PLP is known to be static, this field should be set to '1' in order to enable receivers to extract the PLP even if there is a bit error in the L1 post- or in-band type A signalling.

**STATIC\_PADDING\_FLAG:** This 1-bit field indicates whether BBFRAME padding (clause 5.2.2) is used other than for in-band signalling (clause 5.2.3) for the current PLP. If this field is set to '1', the following shall apply for the current PLP:

- the first BBFRAME of each Interleaving Frame may have  $DFL < K_{bch} - 80$ ; but
- DFL for the first BBFRAME of the Interleaving Frame shall be the same in each Interleaving Frame of a super-frame;
- DFL for the first BBFRAME of the Interleaving Frame shall change only at a super-frame boundary and only if a configuration change is signalled using the L1\_CHANGE\_COUNTER mechanism (see clause 7.2.3.2);
- all other BBFRAMEs shall have  $DFL = K_{bch} - 80$ .

If the STATIC\_PADDING\_FLAG field is set to '0', the value of DFL for the current PLP may vary from BBFRAME to BBFRAME. For backwards compatibility with previous versions of the present document, this field may be set to '0' even when BBFRAME padding is not used, provided T2\_VERSION in the L1-pre signalling is set to '0000' (see clause 7.2.2).

NOTE 2: If BBFRAME padding is known not to be used, this field should be set to '1' in order to enable receivers to extract a PLP even if there is a bit error in the BBHEADER.

**FEF\_LENGTH\_MSB:** This 2-bit field carries the two MSBs of the value of FEF\_LENGTH for a T2-Lite signal to allow longer FEFs to be signalled. For the T2-base profile, these bits are reserved for future use (but shall not be used for bias balancing).

NOTE 3: In version 1.2.1 of the present document the field FEF\_LENGTH\_MSB was part of the following 'RESERVED\_2' field, and may have been set by the bias balancing algorithm (see clause 7.2.3.7). Therefore, these bits can only be assumed to have the correct meaning if the T2\_VERSION field is set to '0010' or greater.

**RESERVED\_2:** This 30-bit field is reserved for future use. It is sometimes used for bias balancing.

The following fields appear in the auxiliary stream loop:

**AUX\_STREAM\_TYPE:** This 4-bit field indicates the type of the current auxiliary stream. The auxiliary stream type is signalled according to table 36.

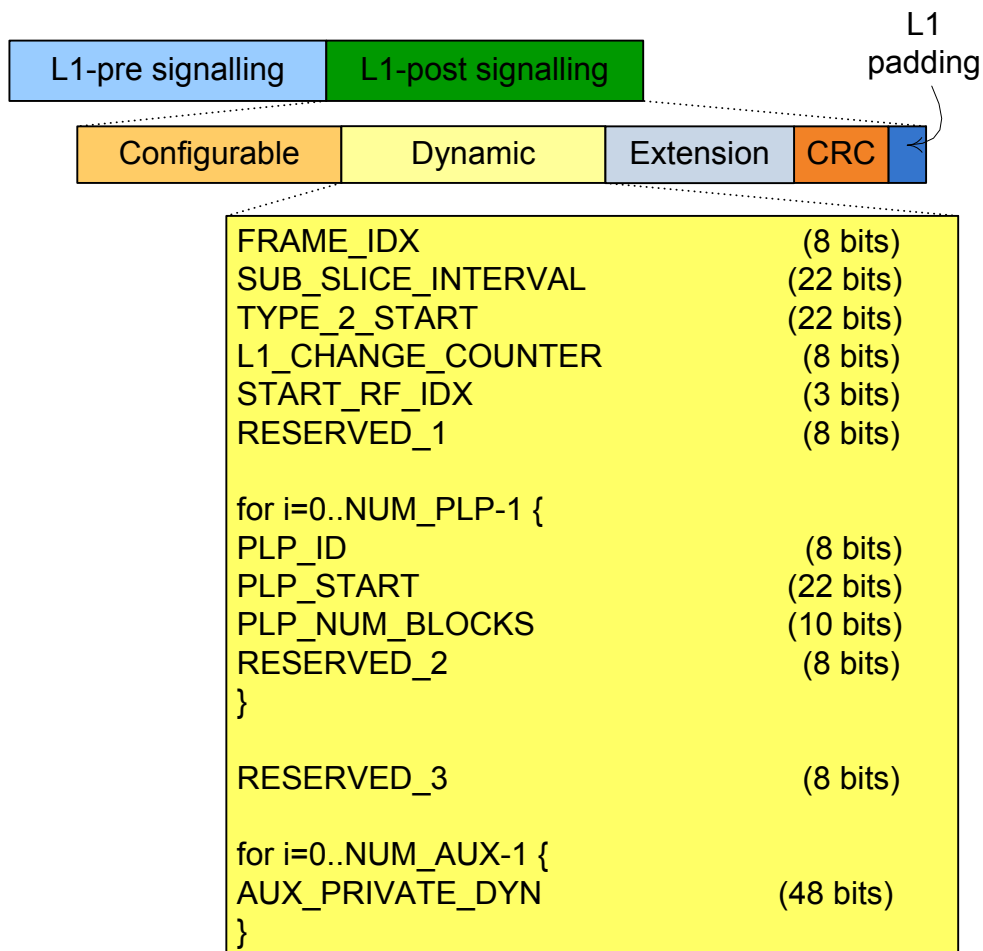
**Table 36: Signalling format for the auxiliary stream type**

Value	Auxiliary stream type
0000	TX-SIG (see TS 102 992 [2])
All other values	Reserved for future use

**AUX\_PRIVATE\_CONF:** This 28-bit field is for future use for signalling auxiliary streams. Its meaning depends on the auxiliary stream type and shall be as defined by the relevant specification document as listed in table 36.

### 7.2.3.2 Dynamic L1-post signalling

The dynamic L1-post signalling is illustrated in figure 28, followed by the detailed definition of each field.



**Figure 28: The signalling fields of the dynamic L1-post signalling**

**FRAME\_IDX:** This 8-bit field is the index of the current T2-frame within a super-frame. The index of the first frame of the super-frame shall be set to '0'.

**SUB\_SLICE\_INTERVAL:** This 22-bit field indicates the number of OFDM cells from the start of one sub-slice of one PLP to the start of the next sub-slice of the same PLP on the same RF channel for the current T2-frame (or the next T2-frame in the case of TFS). If the number of sub-slices per frame equals the number of RF channels, then the value of



this field indicates the number of OFDM cells on one RF channel for the type 2 data PLPs. If there are no type 2 PLPs in the relevant T2-frame, this field shall be set to '0'. The use of this parameter is defined with greater detail in clause 8.3.6.3.3.

**TYPE\_2\_START:** This 22-bit field indicates the start position of the first of the type 2 PLPs using the cell addressing scheme defined in clause 8.3.6.2. If there are no type 2 PLPs, this field shall be set to '0'. It has the same value on every RF channel, and with TFS can be used to calculate when the sub-slices of a PLP are 'folded' (see clause E.2.7.2.4).

**L1\_CHANGE\_COUNTER:** This 8-bit field indicates the number of super-frames ahead where the configuration (i.e. the contents of the fields in the L1-pre signalling or the configurable part of the L1-post signalling) will change. The next super-frame with changes in the configuration is indicated by the value signalled within this field. If this field is set to the value '0', it means that no scheduled change is foreseen. E.g. value '1' indicates that there is change in the next super-frame. This counter shall always start counting down from a minimum value of 2.

**START\_RF\_IDX:** This 3-bit field indicates the ID of the starting frequency of the TFS scheduled frame, for the next T2-frame, as described in annex E. The starting frequency within the TFS scheduled frame may change dynamically. When TFS is not used, the value of this field shall be set to '0'.

**RESERVED\_1:** This 8-bit field is reserved for future use. It is sometimes used for bias balancing.

The following fields appear in the PLP loop:

**PLP\_ID:** This 8-bit field identifies uniquely a PLP within the T2 system. The order of the PLPs within this loop shall be the same as the order within the PLP loop in the L1-post configurable signalling (see clause 7.2.3.1).

NOTE: The PLP\_ID is provided again within this loop to provide an additional check that the correct PLP has been located.

If the PLP\_ID corresponds to a PLP whose PLP\_TYPE is one of the values reserved for future use, the total number of bits in the PLP loop shall be the same as for the other types, but the meanings of the fields other than PLP\_ID shall be reserved for future use and shall be ignored.

**PLP\_START:** This 22-bit field indicates the start position of the associated PLP within the current T2-frame (the next T2-frame in the case of TFS) using the cell addressing scheme defined in clause 8.3.6.2. For type 2 PLPs, this refers to the start position of the first sub-slice of the associated PLP. The first PLP starts after the L1-post signalling and any bias balancing cells. The PLP\_START of the first PLP which is mapped to the current T2-frame shall be higher than the cell address of the highest numbered bias balancing cell. When the current PLP is not mapped to the current T2-frame, or when there are no FEC blocks in the current Interleaving Frame for the current PLP, this field shall be set to '0'.

**PLP\_NUM\_BLOCKS:** This 10-bit field indicates the number of FEC blocks contained in the current Interleaving Frame for the current PLP (in the case of TFS, this refers to the Interleaving Frame which is mapped to the next T2-frame). It shall have the same value for every T2-frame to which the Interleaving Frame is mapped. When the current PLP is not mapped to the current T2-frame (or the next T2-frame in the case of TFS), this field shall be set to '0'.

**RESERVED\_2:** This 8-bit field is reserved for future use. It is sometimes used for bias balancing.

**RESERVED\_3:** This 8-bit field is reserved for future use. It is sometimes used for bias balancing.

The following field appears in the auxiliary stream loop:

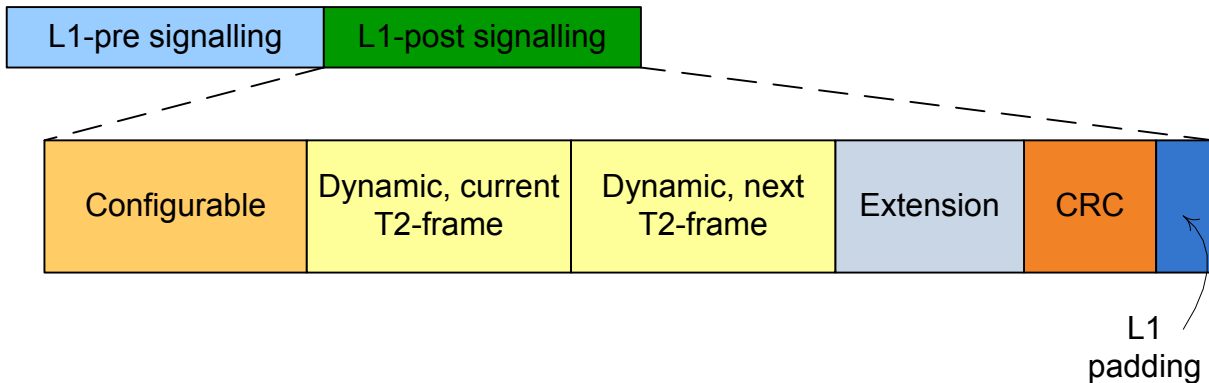
**AUX\_PRIVATE\_DYN:** This 48-bit field is reserved for future use for signalling auxiliary streams. The meaning of this field depends on the value of AUX\_STREAM\_TYPE in the configurable L1 post-signalling (see clause 7.2.3.1) and shall be as defined by the relevant specification document as listed in table 36.

The protection of L1 dynamic signalling is further enhanced by transmitting the L1 signalling also in a form of in-band signalling, see clause 5.2.3.

### 7.2.3.3 Repetition of L1-post dynamic data

To obtain increased robustness for the dynamic part of L1-post signalling, the information may be repeated in the preambles of two successive T2-frames. The use of this repetition is signalled in L1-pre parameter L1\_REPETITION\_FLAG. If the flag is set to '1', dynamic L1-post signalling for the current and next T2-frames are

present in the P2 symbol(s) as illustrated in figure 29. Thus, if repetition of L1-post dynamic data is used, the L1-post signalling consists of one configurable and two dynamic parts as depicted. When TFS is used, these two parts shall signal the information for the next T2-frame and the next-but-one T2-frame respectively.



**Figure 29: Repetition of L1-post dynamic information**

The L1-post signalling shall not change size between the frames of one super-frame. If there is to be a configuration change at the start of super-frame  $j$ , the loops of both parts of the dynamic information of the last T2-frame of super-frame  $j-1$  shall contain only the PLPs and AUXILIARY\_STREAMs present in super-frame  $j-1$ . If a PLP or AUXILIARY\_STREAM is not present in super-frame  $j$ , the fields of the relevant loop shall be set to '0' in super-frame  $j-1$ .

**EXAMPLE:** Super-frame 7 contains 4 PLPs, with PLP\_IDs 0, 1, 2 and 3. A configuration change means that super-frame 8 will contain PLP\_IDs 0, 1, 3 and 4 (i.e. PLP\_ID 2 is to be dropped and replaced by PLP\_ID 4). The last T2-frame of super-frame 7 contains 'current frame' and 'next frame' dynamic information where the PLP loop signals PLP\_IDs 0, 1, 2 and 3 in both cases, even though this is not the correct set of PLP\_IDs for the next frame. In this case the receiver will need to read all of the new configuration information at the start of the new super-frame.

#### 7.2.3.4 L1-post extension field

The L1-post extension field allows for the possibility for future expansion of the L1 signalling. Its presence is indicated by the L1-pre field L1\_POST\_EXTENSION.

If it is present, the L1-post extension shall contain one or more L1-post extension blocks. The syntax of each block shall be as shown in table 37:

**Table 37: Syntax of an L1-post extension block**

Field	Length (bits)	Description
L1_EXT_BLOCK_TYPE	8	Indicates the type of L1-post extension block. See table 38.
L1_EXT_DATA_LEN	16	Indicates the length of the L1_EXT_BLOCK_DATA field in bits.
L1_EXT_BLOCK_DATA	Variable	Contains data specific to the type of L1-post extension block.

Where more than one block is present, each block shall follow contiguously after the previous block. The block or blocks shall exactly fill the L1-post extension field.

The values of L1\_EXT\_BLOCK\_TYPE are defined in table 38.

**Table 38: Values of L1\_EXT\_BLOCK\_TYPE**

L1_EXT_BLOCK_TYPE value	Description
00000000 - 11111110	Reserved for future use
11111111	Padding L1-post extension block

Receivers not aware of the meaning of a particular L1-post extension block shall ignore its contents but shall use the L1\_EXT\_BLOCK\_LEN field to locate the next L1-post extension block, if any.

### 7.2.3.4.1 Padding L1-post extension blocks

L1-post extension blocks of type '11111111' shall contain padding. They may be of any desired length, subject to the capacity of the P2 symbols. The contents of the L1\_EXT\_BLOCK\_DATA field are sometimes used for bias balancing (see clause 7.2.3.7).

### 7.2.3.5 CRC for the L1-post signalling

A 32-bit error detection code is applied to the entire L1-post signalling including the configurable, the dynamic for the current T2-frame, the dynamic for the next T2-frame, if present, and the L1-post extension field, if present. The location of the CRC field can be found from the length of the L1-post, which is signalled by L1\_POST\_INFO\_SIZE. The CRC-32 is defined in annex F.

### 7.2.3.6 L1 padding

This variable-length field is inserted following the L1-post CRC field to ensure that multiple LDPC blocks of the L1-post signalling have the same information size when the L1-post signalling is segmented into multiple blocks and these blocks are separately encoded. Details of how to determine the length of this field are described in clause 7.3.1.2. The values of the L1 padding bits, if any, are set to 0.

### 7.2.3.7 L1 bias balancing bits

As described in clause 7.1, some reserved fields and part of the L1 extension field, if any, are sometimes used for bias balancing and may be set according to the algorithm described in this clause. Other algorithms may also be used for setting these bits. L1 bias balancing bits are used to reduce the imbalance in the number of 1's and 0's in the L1-signalling.

The bias is measured for each T2-frame (before setting the bias balancing bits) by calculating a value  $N_{\text{bias}}$  ( $N_{\text{bias}} = N_{b0} - N_{b1}$ ) for the current T2-frame, where  $N_{b0}$  is the number of 0's and  $N_{b1}$  is the number of 1's in those parts of the L1-signalling to be checked. The parts of the L1 signalling to be checked include all of the bits of the L1-pre and the L1-post except for:

- the CRC;
- the L1 padding field;
- the reserved fields of the L1-pre and L1-post to be used for bias balancing;
- the contents of the L1\_EXT\_BLOCK\_DATA field for any L1-post extension block for which the L1\_EXT\_BLOCK\_TYPE is '11111111'.

Let  $N_{\text{res}}$  be the number of bits used for bias balancing (i.e. the total number of bits in the reserved fields and the relevant part of the L1 extension field, if any). The first  $N_1$  of these  $N_{\text{res}}$  bits, in the order in which they appear, should be set to '1', and the remainder, if any, should be set to '0', where:

$$N_1 = \begin{cases} 0 & \text{if } N_{\text{bias}} < -N_{\text{res}} \\ \left\lfloor \frac{N_{\text{bias}} + N_{\text{res}}}{2} \right\rfloor & \text{if } |N_{\text{bias}}| \leq N_{\text{res}} \\ N_{\text{res}} & \text{if } N_{\text{bias}} > N_{\text{res}} \end{cases}$$

NOTE: If it is required that several modulators produce identical output given the same input, for example when operating in a single frequency network, it will be necessary for the bias balancing bits, along with other parts of the signal to be set in a single central place, such as a T2-gateway (see the note in clause 4.2).

## 7.3 Modulation and error correction coding of the L1 data

### 7.3.1 Overview

#### 7.3.1.1 Error correction coding and modulation of the L1-pre signalling

The L1-pre signalling is protected by a concatenation of BCH outer code and LDPC inner code. The L1-pre signalling bits have a fixed length and they shall be first BCH-encoded, where the BCH parity check bits of the L1-pre signalling shall be appended to the L1-pre signalling. The concatenated L1-pre-signalling and BCH parity check bits are further protected by a shortened and punctured 16K LDPC code with code rate 1/4 ( $N_{ldpc}=16\ 200$ ). Note that effective code rate of the 16K LDPC code with code rate 1/4 is 1/5, where the effective code rate is defined as the information length over the encoder output length. Details of how to shorten and puncture the 16K LDPC code are described in clauses 7.3.2.2, 7.3.2.5 and 7.3.2.6. Note that an input parameter used for defining the shortening operation,  $K_{sig}$  shall be 200, equivalent to the information length of the L1-pre signalling,  $K_{pre}$ . An input parameter used for defining the puncturing operation,  $N_{punc}$  shall be as follows:

$$N_{punc} = \left( K_{bch} - K_{sig} \right) \left( \frac{1}{R_{eff}} - 1 \right) = 11\ 488$$

where  $K_{bch}$  denotes the number of BCH information bits, 3 072, and  $R_{eff}$  denotes the effective LDPC code rate 1/5 for L1-pre signalling. Note that  $N_{punc}$  indicates the number of LDPC parity bits to be punctured.

After the shortening and puncturing, the encoded bits of the L1-pre signalling shall be mapped to:

$\left( K_{sig} + N_{bch\_parity} \right) \frac{1}{R_{eff}} = 1\ 840$  BPSK symbols where  $N_{bch\_parity}$  denotes the number of BCH parity bits, 168 for 16K LDPC codes. Finally, the BPSK symbols are mapped to OFDM cells as described in clause 7.3.3.

#### 7.3.1.2 Error correction coding and modulation of the L1-post signalling

The number of L1-post signalling bits is variable, and the bits shall be transmitted over one or multiple 16K LDPC blocks depending on the length of the L1-post signalling. The number of LDPC blocks for the L1-post signalling,  $N_{post\_FEC\_Block}$  shall be determined as follows:

$$N_{post\_FEC\_Block} = \left\lceil \frac{K_{post\_ex\_pad}}{K_{bch}} \right\rceil,$$

where  $\lceil x \rceil$  means the smallest integer larger than or equal to  $x$ ,  $K_{bch}$  is 7 032 for the 16K LDPC code with code rate 1/2 (effective code rate is 4/9), and  $K_{post\_ex\_pad}$ , which can be found by adding 32 to the parameter L1\_POST\_INFO\_SIZE, denotes the number of information bits of the L1-post signalling excluding the padding field, L1\_PADDING (see clause 7.2.3.6). Then, the length of L1\_PADDING field,  $K_{L1\_PADDING}$  shall be calculated as:

$$K_{L1\_PADDING} = \left\lceil \frac{K_{post\_ex\_pad}}{N_{post\_FEC\_Block}} \right\rceil \times N_{post\_FEC\_Block} - K_{post\_ex\_pad}.$$

The final length of the whole L1-post signalling including the padding field,  $K_{post}$  shall be set as follows:

$$K_{post} = K_{post\_ex\_pad} + K_{L1\_PADDING}.$$

The number of information bits in each of  $N_{post\_FEC\_Block}$  blocks,  $K_{sig}$  is then defined by:

$$K_{sig} = \frac{K_{post}}{N_{post\_FEC\_Block}}.$$

When the L1\_POST\_SCRAMBLED bit is set to a '1', all of the bits of each L1-post block with information size of  $K_{sig}$  are scrambled according to clause 7.3.2.1. Each L1-post block (scrambled or unscrambled) is then protected by a concatenation of BCH outer codes and LDPC inner codes. Each block shall be first BCH-encoded, where its  $N_{bch\_parity}$  (= 168) BCH parity check bits shall be appended to information bits of each block. The concatenated information bits of each block and BCH parity check bits are further protected by a shortened and punctured 16K LDPC code with code rate 1/2 (effective code rate of the 16K LDPC with code rate 1/2,  $R_{eff\_16K\_LDPC\_1\_2}$  is 4/9). Details of how to shorten and puncture the 16K LDPC code are described in clauses 7.3.2.2, 7.3.2.5 and 7.3.2.6.

For a given  $K_{sig}$  and modulation order (BPSK, QPSK, 16-QAM, or 64-QAM are used for the L1-post signalling),  $N_{punc}$  shall be determined by the following steps:

- Step 1)  $N_{punc\_temp} = \max\left(N_{L1\_mult} - 1, \left\lfloor \frac{6}{5} \times (K_{bch} - K_{sig}) \right\rfloor\right)$  where:

$$N_{L1\_mult} = \begin{cases} \text{If } N_{P2} = 1, & 2 \times \eta_{mod} \\ \text{Otherwise,} & N_{P2} \times \eta_{mod} \end{cases}$$

and the operation  $\lfloor x \rfloor$  means the largest integer less than or equal to  $x$ ; and

$$\max(x, y) = \begin{cases} x, & \text{if } x \geq y \\ y, & \text{if } y > x \end{cases}$$

This makes sure that the effective LDPC code rate of the L1-post signalling,  $R_{eff\_post}$  is always lower than or equal to  $R_{eff\_16K\_LDPC\_1\_2}$  (= 4/9). Furthermore,  $R_{eff\_post}$  tends to decrease as the information length  $K_{sig}$  decreases.

- Step 2)  $N_{post\_temp} = K_{sig} + N_{bch\_parity} + N_{ldpc} \times (1 - R_{eff\_16K\_LDPC\_1\_2}) - N_{punc\_temp}$

For the 16K LDPC code with effective code rate 4/9,  $N_{ldpc} \times (1 - R_{eff\_16K\_LDPC\_1\_2}) = 9\,000$ .

$$N_{post} = \begin{cases} \text{If } N_{P2} = 1, & \left\lceil \frac{N_{post\_temp}}{2\eta_{MOD}} \right\rceil \times 2\eta_{MOD}, \\ \text{Otherwise,} & \left\lceil \frac{N_{post\_temp}}{\eta_{MOD} \times N_{P2}} \right\rceil \times \eta_{MOD} \times N_{P2}, \end{cases}$$

- Step 3)

where  $\eta_{MOD}$  denotes the modulation order and it is 1, 2, 4, and 6 for BPSK, QPSK, 16-QAM, and 64-QAM, respectively, and  $N_{P2}$  is the number of P2 symbols of a given FFT size as shown in table 51 in clause 8.3.2.

This step guarantees that  $N_{post}$  is a multiple of the number of columns of the bit interleaver (described in clause 7.3.2.7) and that  $N_{post}/\eta_{MOD}$  is a multiple  $N_{P2}$ .

$$\text{Step 4) } N_{punc} = N_{punc\_temp} - (N_{post} - N_{post\_temp}).$$

$N_{post}$  means the number of the encoded bits for each information block. After the shortening and puncturing, the

encoded bits of each block shall be mapped to  $N_{MOD\_per\_Block} = \frac{N_{post}}{\eta_{MOD}}$  modulated symbols. The total number of the

modulation symbols of  $N_{post\_FEC\_Block}$  blocks,  $N_{MOD\_Total}$  is  $N_{MOD\_Total} = N_{MOD\_per\_Block} \times N_{post\_FEC\_Block}$ .

Note that L1\_POST\_SIZE (an L1-pre signalling field) shall be set to  $N_{MOD\_Total}$ .

When 16-QAM or 64-QAM is used, a bit interleaving shall be applied across each LDPC block. Details of how to interleave the encoded bits are described in clause 7.3.2.7. When BPSK or QPSK is used, bit interleaving shall not be applied. Demultiplexing is then performed as described in clause 7.3.3.1. The demultiplexer output is then mapped to either BPSK, QPSK, 16-QAM, or 64-QAM constellation, as described in clause 6.2.2.

Finally, the modulation symbols are then mapped to carriers as described in clause 8.3.5.

## 7.3.2 Scrambling and FEC Encoding

### 7.3.2.1 Scrambling of L1-post information bits

When the L1\_POST\_SCRAMBLED bit is set to a '1', all of the bits of each L1-post block with information size of  $K_{sig}$  shall be scrambled using the same scrambling sequence as for BBFRAMES (see clause 5.2.4).

NOTE: This feature was not included in versions prior to 1.3.1 of the present document – therefore it should not be enabled in areas where the signal is expected to be demodulated by receivers built according to the earlier versions of the present document.

Each of the  $N_{post\_FEC\_Block}$  L1-post blocks shall be scrambled. The scrambling sequence shall be synchronous with the L1-post block, starting from the MSB and ending after  $K_{sig}$  bits.

The scrambling sequence shall be generated by the feed-back shift register of figure 30. The polynomial for the Pseudo Random Binary Sequence (PRBS) generator shall be:

$$1 + X^{14} + X^{15}$$

Loading of the sequence (10010101000000) into the PRBS register, as indicated in figure 30, shall be initiated at the start of every L1-post block.

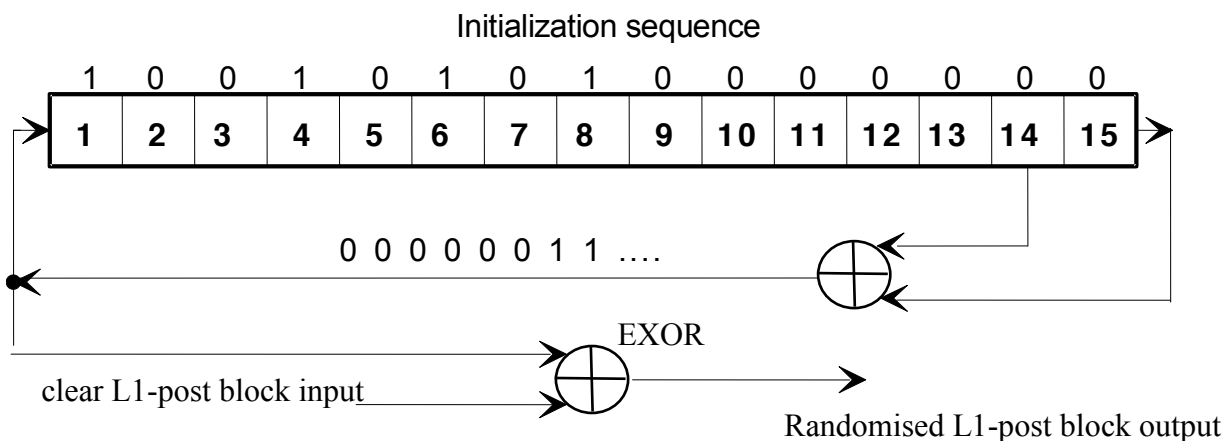


Figure 30: Possible implementation of the PRBS encoder

### 7.3.2.2 Zero padding of BCH information bits

$K_{sig}$  bits defined in clauses 7.3.1.1 and 7.3.1.2, and when required, scrambled according to clause 7.3.2.1, shall be encoded into a 16K ( $N_{ldpc}=16\ 200$ ) LDPC codeword after BCH encoding.

If the  $K_{sig}$  is less than the number of BCH information bits ( $= K_{bch}$ ) for a given code rate, the BCH code will be shortened. A part of the information bits of the 16K LDPC code shall be padded with zeros in order to fill  $K_{bch}$  information bits. The padding bits shall not be transmitted.

All  $K_{bch}$  BCH information bits, denoted by  $\{m_0, m_1, \dots, m_{K_{bch}-1}\}$ , are divided into  $N_{group}$  ( $= K_{ldpc}/360$ ) groups as follows:

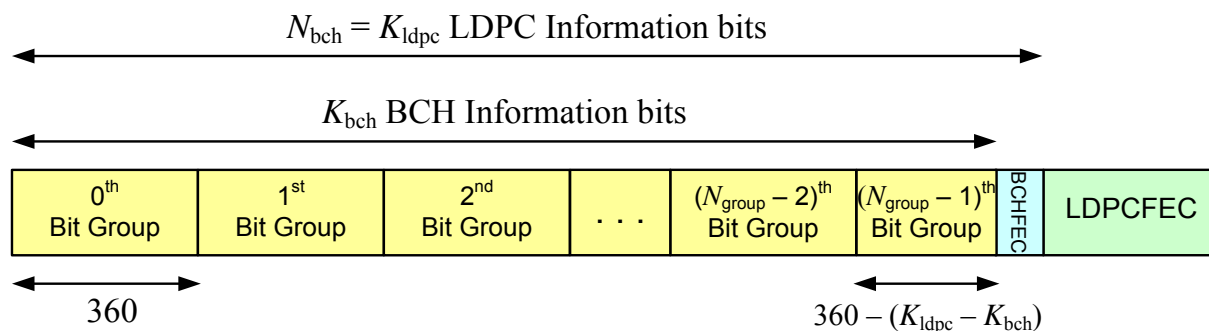
$$X_j = \left\{ m_k \left| j = \left\lfloor \frac{k}{360} \right\rfloor, 0 \leq k < K_{bch} \right. \right\} \text{ for } 0 \leq j < N_{group},$$

where  $X_j$  represents the  $j$ th bit group. The code parameters ( $K_{bch}$ ,  $K_{ldpc}$ ) are given in table 39 for L1-pre and L1-post.

**Table 39: Code parameters ( $K_{bch}$ ,  $K_{ldpc}$ ) for L1-pre and L1-post**

	$K_{bch}$	$K_{ldpc}$
L1-pre signalling	3 072	3 240
L1-post signalling	7 032	7 200

For  $0 \leq j \leq N_{group} - 2$ , each bit group  $X_j$  has 360 bits and the last bit group  $X_{N_{group}-1}$  has  $360 - (K_{ldpc} - K_{bch}) = 192$  bits, as illustrated in figure 31.

**Figure 31: Format of data after LDPC encoding of L1 signalling**

For the given  $K_{sig}$ , the number of zero-padding bits is calculated as  $(K_{bch} - K_{sig})$ . Then, the shortening procedure is as follows:

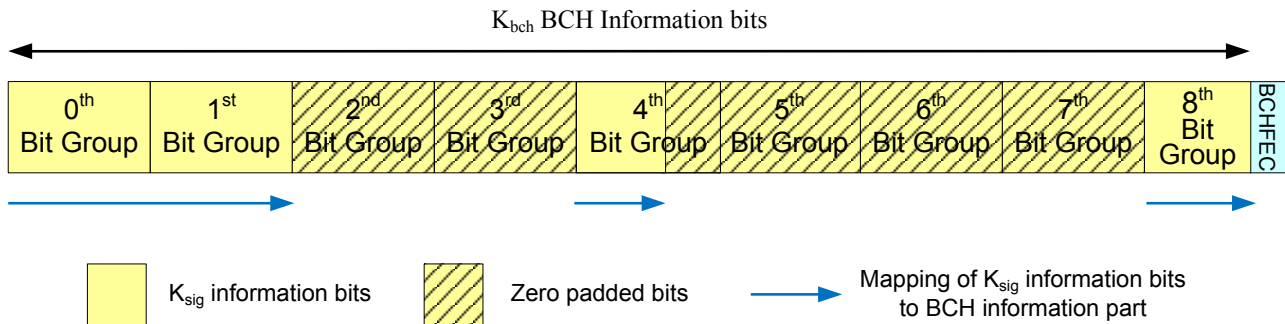
- Step 1) Compute the number of groups in which all the bits shall be padded,  $N_{pad}$  such that:

$$\text{If } 0 < K_{sig} \leq 360, N_{pad} = N_{group} - 1$$

$$\text{Otherwise, } N_{pad} = \left\lfloor \frac{K_{bch} - K_{sig}}{360} \right\rfloor$$

- Step 2) For  $N_{pad}$  groups  $X_{\pi_S(0)}, X_{\pi_S(1)}, \dots, X_{\pi_S(m-1)}, X_{\pi_S(N_{pad}-1)}$ , all information bits of the groups shall be padded with zeros. Here,  $\pi_S$  is a permutation operator depending on the code rate and modulation order, described in tables 40 and 41.
- Step 3) If  $N_{pad} = N_{group} - 1$ ,  $(360 - K_{sig})$  information bits in the last part of the bit group  $X_{\pi_S(N_{group}-1)}$  shall be additionally padded. Otherwise, for the group  $X_{\pi_S(N_{pad})}$ ,  $(K_{bch} - K_{sig} - 360 \times N_{pad})$  information bits in the last part of  $X_{\pi_S(N_{pad})}$  shall be additionally padded.
- Step 4) Finally,  $K_{sig}$  information bits are sequentially mapped to bit positions which are not padded in  $K_{bch}$  BCH information bits,  $\{m_0, m_1, \dots, m_{K_{bch}-1}\}$  by the above procedure.

**EXAMPLE:** Suppose for example the value of  $K_{sig}$  is 1 172 and  $K_{bch}$  is 3 072. In this case, from step (1), 5 groups would have all zero padded bits, and from step (2) these groups would be those with numbers 7, 3, 6, 5, 2. From step (3), an additional 100 bits would be zero padded in group 4. Finally from step (4) the 1 172 bits would be mapped sequentially to groups 0, 1 (360 bits each), the first part of group 4 (260 bits) and group 8 (192 bits). Figure 32 illustrates the shortening of the BCH information part in this case, i.e. filling BCH information bit positions not zero padded with  $K_{sig}$  information bits.



**Figure 32: Example of Shortening of BCH information part**

**Table 40: Permutation sequence of information bit group to be padded for L1-pre signalling**

Modulation and Code rate		$N_{group}$	$\pi_s(j) \quad (0 \leq j < N_{group})$								
			$\pi_s(0)$	$\pi_s(1)$	$\pi_s(2)$	$\pi_s(3)$	$\pi_s(4)$	$\pi_s(5)$	$\pi_s(6)$	$\pi_s(7)$	$\pi_s(8)$
BPSK	1/4	9	7	3	6	5	2	4	1	8	0

**Table 41: Permutation sequence of information bit group to be padded for L1-post signalling**

Modulation and Code rate		$N_{group}$	$\pi_s(j) \quad (0 \leq j < N_{group})$										
			$\pi_s(0)$	$\pi_s(1)$	$\pi_s(2)$	$\pi_s(3)$	$\pi_s(4)$	$\pi_s(5)$	$\pi_s(6)$	$\pi_s(7)$	$\pi_s(8)$	$\pi_s(9)$	
			$\pi_s(10)$	$\pi_s(11)$	$\pi_s(12)$	$\pi_s(13)$	$\pi_s(14)$	$\pi_s(15)$	$\pi_s(16)$	$\pi_s(17)$	$\pi_s(18)$	$\pi_s(19)$	
BPSK/QPSK	1/2	20	18	17	16	15	14	13	12	11	4	10	
			9	8	3	2	7	6	5	1	19	0	
16-QAM	1/2	20	18	17	16	15	14	13	12	11	4	10	
			9	8	7	3	2	1	6	5	19	0	
64-QAM	1/2	20	18	17	16	4	15	14	13	12	3	11	
			10	9	2	8	7	1	6	5	19	0	

### 7.3.2.3 BCH encoding

The  $K_{bch}$  information bits (including the  $K_{bch} - K_{sig}$  zero padding bits) shall first be BCH encoded according to clause 6.1.1 to generate  $N_{bch} = K_{ldpc}$  output bits ( $i_0 \dots i_{N_{bch}-1}$ ).

### 7.3.2.4 LDPC encoding

The  $N_{bch} = K_{ldpc}$  output bits ( $i_0 \dots i_{N_{bch}-1}$ ) from the BCH encoder, including the  $(K_{bch} - K_{sig})$  zero padding bits and the  $(K_{ldpc} - K_{bch})$  BCH parity bits form the  $K_{ldpc}$  information bits  $\mathbf{I} = (i_0, i_1, \dots, i_{K_{ldpc}-1})$  for the LDPC encoder. The LDPC encoder shall systematically encode the  $K_{ldpc}$  information bits onto a codeword  $\mathbf{A}$  of size  $N_{ldpc}$ :

$$\mathbf{A} = (i_0, i_1, \dots, i_{K_{ldpc}-1}, p_0, p_1, \dots, p_{N_{ldpc}-K_{ldpc}-1}) \text{ according to clause 6.1.2.}$$

### 7.3.2.5 Puncturing of LDPC parity bits

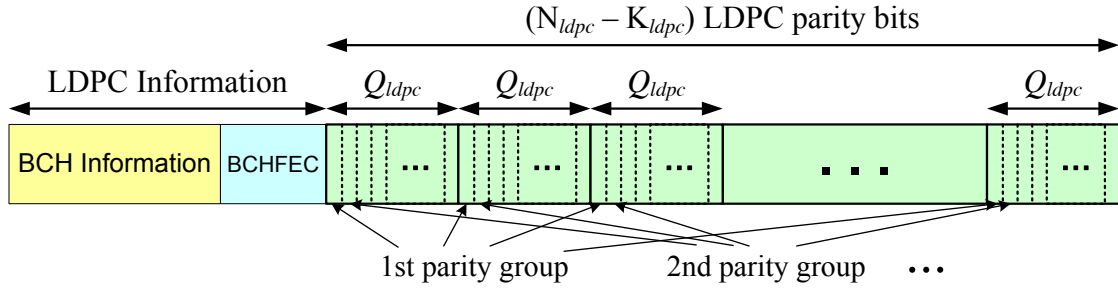
When the shortening is applied to encoding of the signalling bits, some LDPC parity bits shall be punctured after the LDPC encoding. These punctured bits shall not be transmitted.

All  $N_{ldpc} - K_{ldpc}$  LDPC parity bits, denoted by  $\{p_0, p_1, \dots, p_{N_{ldpc}-K_{ldpc}-1}\}$ , are divided into  $Q_{ldpc}$  parity groups where each parity group is formed from a sub-set of the  $N_{ldpc} - K_{ldpc}$  LDPC parity bits as follows:

$$P_j = \left\{ p_k \mid k \bmod Q_{ldpc} = j, 0 \leq k < N_{ldpc} - K_{ldpc} \right\} \text{ for } 0 \leq j < Q_{ldpc},$$



where  $P_j$  represents the  $j$ th parity group and  $Q_{ldpc}$  is given in table 8(b). Each group has  $(N_{ldpc} - K_{ldpc})/Q_{ldpc} = 360$  bits, as illustrated in figure 33.



**Figure 33: Parity bit groups in an FEC block**

For the number of parity bits to be punctured,  $N_{punc}$  given in clauses 7.3.1.1 and 7.3.1.2.

- Step 1) Compute the number of groups in which all parity bits shall be punctured,  $N_{punc\_groups}$  such that:

$$N_{punc\_groups} = \left\lfloor \frac{N_{punc}}{360} \right\rfloor \text{ for } 0 \leq N_{punc} < N_{ldpc} - K_{ldpc}.$$

- Step 2) For  $N_{punc\_groups}$  parity bit groups  $P_{\pi_p(0)}, P_{\pi_p(1)}, \dots, P_{\pi_p(N_{punc\_groups}-1)}$ , all parity bits of the groups shall be punctured. Here,  $\pi_p$  is a permutation operator depending on the code rate and modulation order, described in tables 42 and 43.
- Step 3) For the group  $P_{\pi_p(N_{punc\_groups})}$ ,  $\lfloor \frac{N_{punc}}{360} \rfloor \times 360$  parity bits in the first part of the group shall be additionally punctured.

**Table 42: Permutation sequence of parity group to be punctured for L1-pre signalling**

Modulation and Code rate		Order of parity group to be punctured, $\{\pi_p(j), 0 \leq j < Q_{ldpc} = 36\}$																	
		$\pi_p(0)$	$\pi_p(1)$	$\pi_p(2)$	$\pi_p(3)$	$\pi_p(4)$	$\pi_p(5)$	$\pi_p(6)$	$\pi_p(7)$	$\pi_p(8)$	$\pi_p(9)$	$\pi_p(10)$	$\pi_p(11)$	$\pi_p(12)$	$\pi_p(13)$	$\pi_p(14)$	$\pi_p(15)$	$\pi_p(16)$	$\pi_p(17)$
		$\pi_p(18)$	$\pi_p(19)$	$\pi_p(20)$	$\pi_p(21)$	$\pi_p(22)$	$\pi_p(23)$	$\pi_p(24)$	$\pi_p(25)$	$\pi_p(26)$	$\pi_p(27)$	$\pi_p(28)$	$\pi_p(29)$	$\pi_p(30)$	$\pi_p(31)$	$\pi_p(32)$	$\pi_p(33)$	$\pi_p(34)$	$\pi_p(35)$
BPSK	1/4	27	13	29	32	5	0	11	21	33	20	25	28	18	35	8	3	9	31
		22	24	7	14	17	4	2	26	16	34	19	10	12	23	1	6	30	15

**Table 43: Permutation sequence of parity group to be punctured for L1-post signalling**

Modulation and Code rate		Order of parity group to be punctured, $\{\pi_p(j), 0 \leq j < Q_{ldpc} = 25\}$												
		$\pi_p(0)$	$\pi_p(1)$	$\pi_p(2)$	$\pi_p(3)$	$\pi_p(4)$	$\pi_p(5)$	$\pi_p(6)$	$\pi_p(7)$	$\pi_p(8)$	$\pi_p(9)$	$\pi_p(10)$	$\pi_p(11)$	$\pi_p(12)$
		$\pi_p(13)$	$\pi_p(14)$	$\pi_p(15)$	$\pi_p(16)$	$\pi_p(17)$	$\pi_p(18)$	$\pi_p(19)$	$\pi_p(20)$	$\pi_p(21)$	$\pi_p(22)$	$\pi_p(23)$	$\pi_p(24)$	-
BPSK / QPSK	1/2	6	4	18	9	13	8	15	20	5	17	2	24	10
		22	12	3	16	23	1	14	0	21	19	7	11	-
16-QAM	1/2	6	4	13	9	18	8	15	20	5	17	2	22	24
		7	12	1	16	23	14	0	21	10	19	11	3	-
64-QAM	1/2	6	15	13	10	3	17	21	8	5	19	2	23	16
		24	7	18	1	12	20	0	4	14	9	11	22	-

### 7.3.2.6 Removal of zero padding bits

The  $(K_{bch} - K_{sig})$  zero padding bits are removed and shall not be transmitted. This leaves a word consisting of the  $K_{sig}$  information bits, followed by the 168 BCH parity bits and  $(N_{ldpc} - K_{ldpc} - N_{punc})$  LDPC parity bits.

### 7.3.2.7 Bit interleaving for L1-post signalling

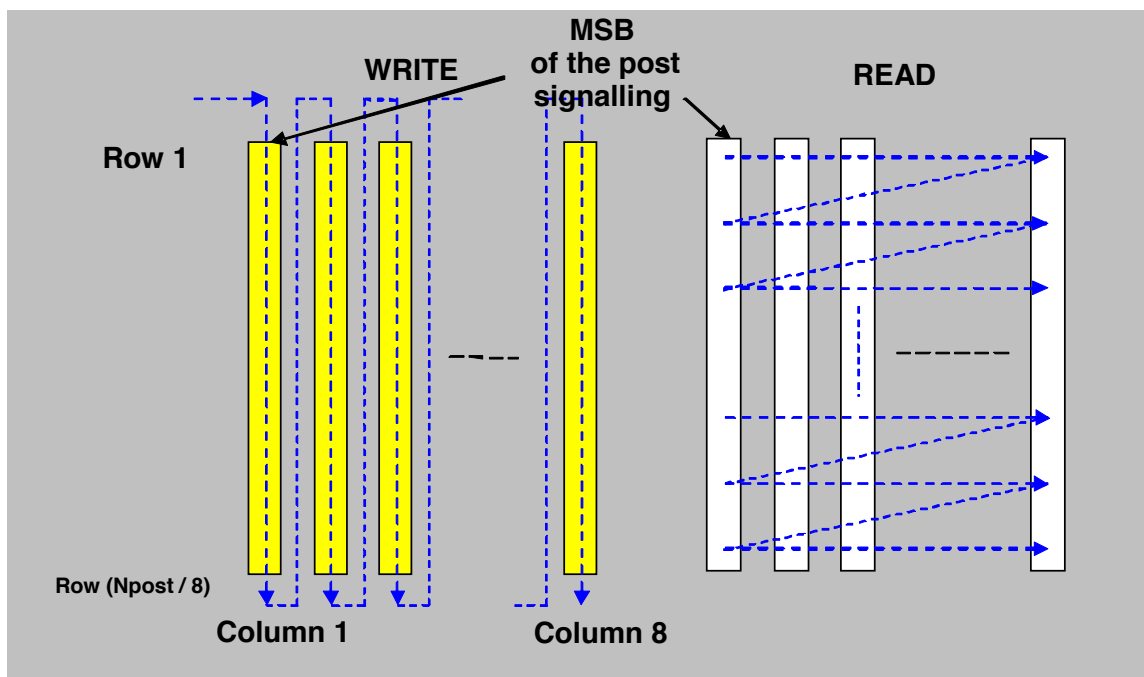
When 16-QAM or 64-QAM modulation is used for the L1-post signalling, the LDPC codeword of length  $N_{post}$ , consisting of  $K_{sig}$  information bits, 168 BCH parity bits, and  $(9\,000 - N_{punc})$  LDPC parity bits, shall be bit-interleaved using a block interleaver. The configuration of the bit interleaver for each modulation is specified in table 44.

**Table 44: Bit Interleaver structure**

Modulation and Code rate	Rows Nr	Columns Nc
16-QAM	$N_{post} / 8$	8
64-QAM	$N_{post} / 12$	12

The LDPC codeword is serially written into the interleaver column-wise, and serially read out row-wise (the MSB of the L1-post signalling is read out first) as shown in figure 34.

When BPSK or QPSK is used, bit interleaving shall not be applied.



**Figure 34: Bit Interleaving scheme for L1-post (16-QAM)**

## 7.3.3 Mapping bits onto constellations

Each bit-interleaved LDPC codeword shall be mapped onto constellations. Each bit of the L1-pre signalling is mapped directly into a BPSK constellation according to clause 7.3.3.2, whereas the L1-post signalling is first demultiplexed into cell words according to clause 7.3.3.1 and then the cell words are mapped into constellations according to clause 7.3.3.2. The constellations of both L1-pre signalling and L1-post signalling are then modified according to the L1-ACE algorithm defined in clause 7.3.3.3.

### 7.3.3.1 Demultiplexing of L1-post signalling

Each bit-interleaved punctured and shortened LDPC codeword, a sequence of  $N_{post}$  bits,  $V = (v_0 \dots v_{N_{post}-1})$ , where  $N_{post} = K_{sig} + 168 + 9\,000 - N_{punc}$ , shall be mapped onto constellations by first de-multiplexing the input bits into parallel cell words and then mapping these cell words into constellation values. The number of output data cells and the effective number of bits per cell,  $\eta_{MOD}$  are defined by table 45.

The input bit-stream  $v_{di}$  is demultiplexed into  $N_{\text{substreams}}$  sub-streams  $b_{e,do}$ , as shown in figure 14 in clause 6.2.1. The value of  $N_{\text{substreams}}$  is defined in table 45. Details of demultiplexing are described in clause 6.2.1. For QPSK, 16-QAM, and 64-QAM, the parameters for de-multiplexing of bits to cells are the same as those of table 13(a) in clause 6.2.1. For BPSK, the input number and the output bit-number are 0, and in this case the demultiplexing has no effect.

**Table 45: Parameters for bit-mapping into constellations**

Modulation mode	$\eta_{\text{MOD}}$	Number of output data cells per codeword	Number of sub-streams, $N_{\text{substreams}}$
BPSK	1	$N_{\text{post}}$	1
QPSK	2	$N_{\text{post}} / 2$	2
16-QAM	4	$N_{\text{post}} / 4$	8
64-QAM	6	$N_{\text{post}} / 6$	12

For 16-QAM and 64-QAM, the output words from the demultiplexing of width  $N_{\text{substreams}}$   $[b_{0,do} \cdot b_{N_{\text{substreams}}-1,do}]$  are split into two words of width  $\eta_{\text{MOD}} = N_{\text{substreams}} / 2$   $[y_{0,2do} \cdot y_{\eta_{\text{mod}}-1,2do}]$  and  $[y_{0,2do+1} \cdot y_{\eta_{\text{mod}}-1,2do+1}]$  as described in clause 6.2.1. For BPSK and QPSK, the output words are fed directly to the constellation mapper, so  $[y_{0,do} \cdot y_{\eta_{\text{mod}}-1,do}] = [b_{0,do} \cdot b_{N_{\text{substreams}}-1,do}]$ .

### 7.3.3.2 Mapping into I/Q constellations

The bits of the L1-pre signalling  $y_{0,q}$  and the cell words of the L1-post signalling  $[y_{0,q} \cdot y_{\eta_{\text{mod}}-1,q}]$  are mapped into constellations  $f_{\text{pre}_q}$  and  $f_{\text{post}_q}$  respectively according to clause 6.2.2, where  $q$  is the index of the cells within each bit-interleaved LDPC codeword. For the L1-pre signalling,  $0 \leq q < 1\ 840$ , and for the L1-post signalling  $0 \leq q < N_{\text{MOD}_per\_Block}$ . The coded and modulated cells of the L1-post signalling corresponding to each codeword of T2-frame number  $m$  are then concatenated to form a single block of cells  $f_{\text{post}_{m,i}}$ , where  $i$  is the index of the cells within the single block  $0 \leq i < N_{\text{MOD}_Total}$ . The coded and modulated cells of the L1-pre signalling for T2-frame number  $m$  form a single block of cells  $f_{\text{pre}_{m,i}}$ , where  $i$  is the index of the cells within the single block  $0 \leq i < 1\ 840$ .

### 7.3.3.3 Modification of L1 signalling constellations by L1-ACE algorithm

To further reduce the bias in the L1 signalling, if the T2\_VERSION field (see clause 7.2.2) is set to a value greater than '0000', a small modification of the modulated L1 cells shall be applied. This clause describes the algorithm to be applied to all of the BPSK cells of the L1-pre signalling, and to all of the cells of the L1-post signalling, whichever constellation is used for the L1-post cells.

The cells of the L1 signalling are modified by adding a small correction  $c_{\text{pre}_{m,i}}$  and  $c_{\text{post}_{m,i}}$  so that the values of the cells after the L1-ACE algorithm are  $f'_{\text{pre}_{m,i}} = (f_{\text{pre}_{m,i}} + c_{\text{pre}_{m,i}})$  and  $f'_{\text{post}_{m,i}} = (f_{\text{post}_{m,i}} + c_{\text{post}_{m,i}})$ .

If the T2\_VERSION field is set to '0000', the L1-ACE algorithm shall not be applied, and  $f'_{\text{pre}_{m,i}} = f_{\text{pre}_{m,i}}$  and  $f'_{\text{post}_{m,i}} = f_{\text{post}_{m,i}}$ .

Let  $L$  be the maximum value of the real or imaginary part of the L1-post constellation. Hence  $L = \frac{1}{\sqrt{2}}$  for QPSK,

$L = \frac{3}{\sqrt{10}}$  for 16-QAM and  $L = \frac{7}{\sqrt{42}}$  for 64-QAM. The maximum correction to be applied is a parameter of the system denoted by  $C_{\text{L1\_ACE\_MAX}}$ .

The algorithm consists of the following steps:

1. Calculate the total L1 bias:

$$C_{\text{bias}}(m) = \sum_{i=0}^{1839} f_{\text{pre}_{m,i}} + \sum_{i=0}^{N_{\text{MOD\_Total}}-1} f_{\text{post}_{m,i}}.$$

2. If the L1 bias will be fully corrected by the bias balancing cells, no L1-ACE correction is necessary. Hence if:

$$|C_{\text{bias}}(m)| \leq N_{\text{P2}} N_{\text{biasCellsActive}}$$

set  $c_{\text{pre}_{m,i}} = 0$ ;  $c_{\text{post}_{m,i}} = 0$  and go to step 12.

3. If there are insufficient bias balancing cells to fully correct the L1 bias, the bias is reduced by the amount of correction to be applied by the bias balancing cells:

$$C_{\text{bias\_L1\_ACE}}(m) = C_{\text{bias}}(m) - N_{\text{P2}} N_{\text{biasCellsActive}} \frac{C_{\text{bias}}(m)}{|C_{\text{bias}}(m)|}.$$

4. Resolve the bias to be corrected by the L1-ACE algorithm into real and imaginary components:

$$C_{\text{re}}(m) = \text{Re}[C_{\text{bias\_L1\_ACE}}(m)]; C_{\text{im}} = \text{Im}[C_{\text{bias\_L1\_ACE}}(m)].$$

5. Define correction levels  $L_{\text{pre}}(m)$ ,  $L_{\text{re\_post}}(m)$  and  $L_{\text{im}}(m)$ :

If  $C_{\text{re}}(m) < 0$ ,  $L_{\text{pre}}(m) = 1$  and  $L_{\text{re\_post}}(m) = L$  otherwise  $L_{\text{pre}}(m) = -1$  and  $L_{\text{re\_post}}(m) = -L$ .

If  $C_{\text{im}}(m) < 0$ ,  $L_{\text{im}}(m) = L$  otherwise  $L_{\text{im}}(m) = -L$ .

6. Let  $N_{\text{pre}}(m)$  be the number of L1-pre cells in frame  $m$  for which  $f_{\text{pre}_{m,i}} = L_{\text{pre}}(m)$ .
7. Let  $N_{\text{re\_post}}(m)$  be the number of L1-post cells in frame  $m$  for which  $\text{Re}(f_{\text{post}_{m,i}}) = L_{\text{re\_post}}(m)$ .
8. Let  $N_{\text{im}}(m)$  be the number of L1-post cells in frame  $m$  for which  $\text{Im}(f_{\text{post}_{m,i}}) = L_{\text{im}}(m)$ .
9. Calculate  $N_{\text{re}}(m) = N_{\text{pre}}(m) + N_{\text{re\_post}}(m)$ .
10. Calculate the correction to be applied to the relevant cells in frame  $m$ ,  $c_{\text{cell\_pre}}(m)$ ,  $c_{\text{cell\_re\_post}}(m)$  and  $c_{\text{cell\_im}}(m)$ :

$$c_{\text{cell\_pre}}(m) = \min\left(\frac{|C_{\text{re}}(m)|}{N_{\text{re}}(m)}, C_{\text{L1\_ACE\_MAX}}\right) \times \text{sign}[L_{\text{pre}}(m)]$$

$$c_{\text{cell\_re\_post}}(m) = \min\left(\frac{|C_{\text{re}}(m)|}{N_{\text{re}}(m)}, C_{\text{L1\_ACE\_MAX}}\right) \times \text{sign}[L_{\text{re\_post}}(m)]$$

$$c_{\text{cell\_im}}(m) = \min\left(\frac{|C_{\text{im}}(m)|}{N_{\text{im}}(m)}, C_{\text{L1\_ACE\_MAX}}\right) \times \text{sign}[L_{\text{im}}(m)]$$

11. Apply the correction to the relevant cells of frame  $m$  according to:

If  $f_{\text{pre}_{m,i}} = L_{\text{pre}}(m)$ ,  $c_{\text{pre}_{m,i}} = c_{\text{cell\_pre}}(m)$ , else  $c_{\text{pre}_{m,i}} = 0$ ;

If  $\text{Re}(f_{\text{post}_{m,i}}) = L_{\text{re\_post}}(m)$ ,  $\text{Re}(c_{\text{post}_{m,i}}) = c_{\text{cell\_re\_post}}(m)$ , else  $\text{Re}(c_{\text{post}_{m,i}}) = 0$ ;

If  $\text{Im}(f_{\text{post}_{m,i}}) = L_{\text{im}}(m)$ ,  $\text{Im}(c_{\text{post}_{m,i}}) = c_{\text{cell\_im}}(m)$ , else  $\text{Im}(c_{\text{post}_{m,i}}) = 0$ ;

12. The modified cells of the L1-pre and L1-post signalling,  $f'_{\text{pre}_{m,i}} = (f_{\text{pre}_{m,i}} + c_{\text{pre}_{m,i}})$  and  $f'_{\text{post}_{m,i}} = (f_{\text{post}_{m,i}} + c_{\text{post}_{m,i}})$ , are then mapped onto the P2 symbol(s) as described in clause 8.3.5.

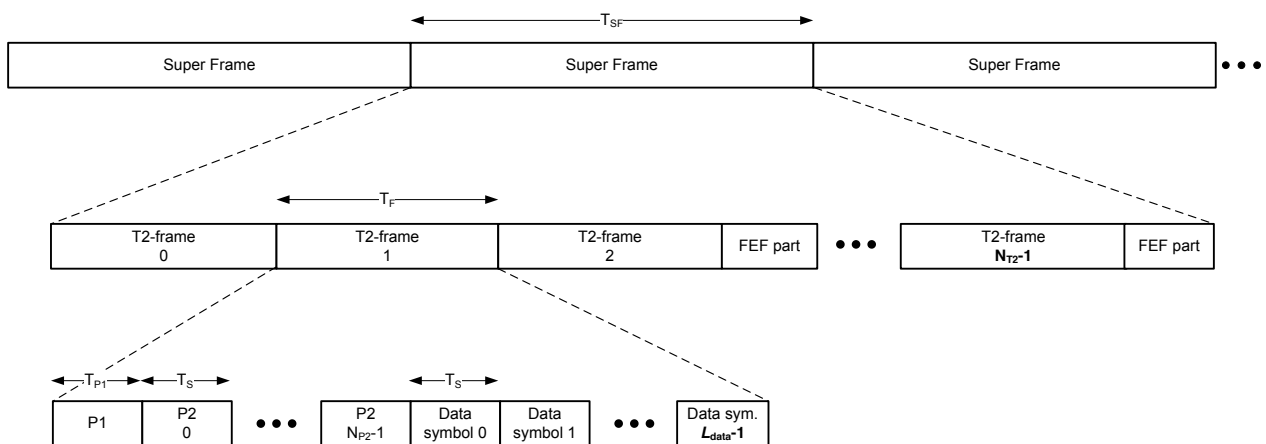
## 8 Frame Builder

This clause defines the frame builder functions that always apply for a T2 system with a single RF channel. Some of the frame builder functions for a TFS system with multiple RF channels differ from those defined in this clause. The TFS specific frame builder functions are defined in annex E. Other frame builder functions for a TFS system than those specified in annex E apply as they are described in this clause.

The function of the frame builder is to assemble the cells produced by the time interleavers for each of the PLPs and the cells of the modulated L1 signalling data into arrays of active OFDM cells corresponding to each of the OFDM symbols which make up the overall frame structure. The frame builder operates according to the dynamic information produced by the scheduler (see clause 5.2.1) and the configuration of the frame structure.

**NOTE:** The frame structure and associated parameters are modified for T2-Lite – see annex I.8.1 Frame structure

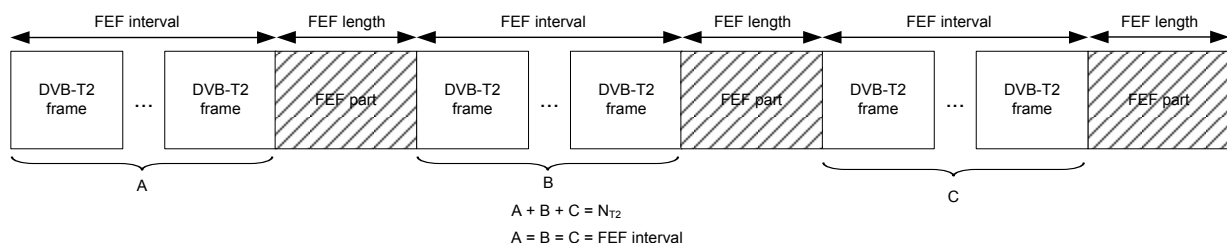
The DVB-T2 frame structure is shown in figure 35. At the top level, the frame structure consists of super-frames, which are divided into T2-frames and these are further divided into OFDM symbols. The super-frame may in addition have FEF parts (see clause 8.4).



**Figure 35: The DVB-T2 frame structure, showing the division into super-frames, T2-frames and OFDM symbols**

### 8.2 Super-frame

A super-frame can carry T2-frames and may also have FEF parts, see figure 36.



**Figure 36: The super-frame, including T2-frames and FEF parts**

The number of T2-frames in a super-frame is a configurable parameter  $N_{T2}$  that is signalled in L1-pre signalling, i.e.  $N_{T2} = \text{NUM\_T2\_FRAMES}$  (see clause 7.2.2). The T2-frames are numbered from 0 to  $N_{T2}-1$ . The current frame is signalled by `FRAME_IDX` in the dynamic L1-post signalling.

A FEF part may be inserted between T2-frames. There may be several FEF parts in the super-frame, but a FEF part shall not be adjacent to another FEF part. The location in time of the FEF parts is signalled based on the super-frame structure. The super-frame duration  $T_{SF}$  is determined by:

$$T_{SF} = N_{T2} \times T_F + N_{FEF} \times T_{FEF},$$

where  $N_{FEF}$  is the number of FEF parts in a super-frame and  $T_{FEF}$  is the duration of the FEF part and is signalled by FEF\_LENGTH.  $N_{FEF}$  can be derived as:

$$N_{FEF} = N_{T2} / \text{FEF\_interval}.$$

If FEFs are used, the super-frame ends with a FEF part.

The maximum value for the super-frame length  $T_{SF}$  is 63.75s if FEFs are not used (equivalent to 255 frames of 250 ms) and 127.5s if FEFs are used. Note also that the indexing of T2-frames (see FRAME\_IDX in clause 7.2.3.2) and  $N_{T2}$  are independent of Future Extension Frames.

The L1-pre signalling and the configurable part of the L1-post signalling can be changed only on the border of two super-frames. If the receiver receives only the in-band type A, there is a counter that indicates the next super-frame with changes in L1 parameters. Then the receiver can check the new L1 parameters from the P2 symbol(s) in the first frame of the announced super-frame, where the change applies.

A data PLP does not have to be mapped into every T2-frame. It can jump over multiple frames. This frame interval ( $I_{JUMP}$ ) is determined by the FRAME\_INTERVAL parameter. The first frame where the data PLP appears is determined by FIRST\_FRAME\_IDX. FRAME\_INTERVAL and FIRST\_FRAME\_IDX shall be signalled in the L1-post signalling (see clause 7.2.3.1). In order to have unique mapping of the data PLPs between super-frames,  $N_{T2}$  shall be divisible by FRAME\_INTERVAL for every data PLP. The PLP shall be mapped to the T2-frames for which:

$$(\text{FRAME\_IDX} - \text{FIRST\_FRAME\_IDX}) \bmod \text{FRAME\_INTERVAL} = 0.$$

Note that when the in-band signalling is determined and inserted inside the data PLP, this requires buffering of FRAME\_INTERVAL+1 T2-frames in a T2 system with one RF channel. If using TFS, the buffering is over FRAME\_INTERVAL+2 T2-frames. In order to avoid buffering, in-band type A is optional for PLPs that do not appear in every frame and for PLPs that are time interleaved over more than one frame.

$N_{T2}$  must be chosen so that for every data PLP there is an integer number of Interleaving Frames per super-frame.

## 8.3 T2-Frame

The T2-frame comprises one P1 preamble symbol, followed by one or more P2 preamble symbols, followed by a configurable number of data symbols. In certain combinations of FFT size, guard interval and pilot pattern (see clause 9.2.7), the last data symbol shall be a frame closing symbol. The details of the T2-frame structure are described in clause 8.3.2.

The P1 symbols are unlike ordinary OFDM symbols and are inserted later (see clause 9.8).

The P2 symbol(s) follow immediately after the P1 symbol. The main purpose of the P2 symbol(s) is to carry L1 signalling data. The L1 signalling data to be carried is described in clause 7.2, its modulation and error correction coding are described in clause 7.3 and the mapping of this data onto the P2 symbol(s) is described in clause 8.3.5.

### 8.3.1 Duration of the T2-Frame

The beginning of the first preamble symbol (P1) marks the beginning of the T2-frame.

The number of P2 symbols  $N_{p2}$  is determined by the FFT size as given in table 51, whereas the number of data symbols  $L_{data}$  in the T2-frame is a configurable parameter signalled in the L1-pre signalling, i.e.  $L_{data} = \text{NUM\_DATA\_SYMBOLS}$ . The total number of symbols in a frame (excluding P1) is given by  $L_F = N_{p2} + L_{data}$ . The T2-frame duration is therefore given by:

$$T_F = L_F \times T_s + T_{p1},$$

where  $T_s$  is the total OFDM symbol duration and  $T_{P1}$  is the duration of the P1 symbol (see clause 9.5).

The maximum value for the frame duration  $T_F$  shall be 250 ms. Thus, the maximum number for  $L_F$  is as defined in table 46 (for 8 MHz bandwidth).

**Table 46: Maximum frame length  $L_F$  in OFDM symbols for different FFT sizes and guard intervals (for 8 MHz bandwidth)**

FFT size	$T_u$ [ms]	Guard interval						
		1/128	1/32	1/16	19/256	1/8	19/128	1/4
32K	3,584	68	66	64	64	60	60	NA
16K	1,792	138	135	131	129	123	121	111
8K	0,896	276	270	262	259	247	242	223
4K	0,448	NA	540	524	NA	495	NA	446
2K	0,224	NA	1081	1 049	NA	991	NA	892
1K	0,112	NA	NA	2 098	NA	1 982	NA	1 784

The minimum number of OFDM symbols  $L_F$  shall be  $N_{P2}+3$  when the FFT size is 32K and  $N_{P2}+7$  in other modes. When the FFT size is 32K, the number of OFDM symbols  $L_F$  shall be even.

The P1 symbol carries only P1 specific signalling information (see clause 7.2.1). P2 symbol(s) carry all the remaining L1 signalling information (see clauses 7.2.2 and 7.2.3), any bias balancing cells (see clause 8.3.6.3.1) and, if there is free capacity, they also carry data from the common PLPs and/or data PLPs. Data symbols carry only common PLPs or data PLPs as defined in clauses 8.3.6.3.2 and 8.3.6.3.3. The mapping of PLPs into the symbols is done at the OFDM cell level, and thus, P2 or data symbols can be shared between multiple PLPs. If there is free capacity left in the T2-frame, it is filled with auxiliary streams (if any) and dummy cells as defined in clauses 8.3.7 and 8.3.8. In the T2-frame, the common PLPs are always located before the data PLPs. The mapping of PLPs into the T2-frame is defined in clause 8.3.6.1.

### 8.3.2 Capacity and structure of the T2-frame

The frame builder shall map the cells from both the time interleaver (for the PLPs) and the constellation mapper (for the L1-pre and L1-post signalling) onto the data cells  $x_{m,l,p}$  of each OFDM symbol in each frame, where:

- $m$  is the T2- frame number;
- $l$  is the index of the symbol within the frame, starting at 0 for the first P2 symbol,  $0 \leq l < L_F$ ;
- $p$  is the index of the data cell within the symbol prior to frequency interleaving and pilot insertion.

Data cells are the cells of the OFDM symbols which are not used for pilots or tone reservation.

The P1 symbol is not an ordinary OFDM symbol and does not contain any active OFDM cells (see clause 9.8).

The number of active carriers, i.e. carriers not used for pilots or tone reservation, in one P2 symbol is denoted by  $C_{P2}$  and is defined in table 47. Thus, the number of active carriers in all P2 symbol(s) is  $N_{P2} \times C_{P2}$ .

The number of active carriers, i.e. carriers not used for pilots, in one normal symbol is denoted by  $C_{data}$  table 48 gives values of  $C_{data}$  for each FFT mode and scattered pilot pattern for the case where tone reservation is not used. The values of  $C_{data}$  when tone reservation is used (see clause 9.6.2) are calculated by subtracting the value in the "TR cells" column from the  $C_{data}$  value without tone reservation. For 8K, 16K and 32K two values are given corresponding to normal carrier mode and extended carrier mode (see clause 9.5).

In some combinations of FFT size, guard interval and pilot pattern, as described in clause 9.2.7, the last symbol of the T2-frame is a special frame closing symbol. It has a denser pilot pattern than the other data symbols and some of the cells are not modulated in order to maintain the same total symbol energy (see clause 8.3.9). When there is a frame closing symbol, the number of data cells it contains is denoted by  $N_{FC}$  and is defined in table 49. The lesser number of active cells, i.e. data cells that are modulated, is denoted by  $C_{FC}$ , and is defined in table 50. Both  $N_{FC}$  and  $C_{FC}$  are tabulated for the case where tone reservation is not used and the corresponding values when tone reservation is used

(see clause 9.6.2) are calculated by subtracting the value in the "TR cells" column from the value without tone reservation.

Hence the cell index  $p$  takes the following range of values:

- $0 \leq p < C_{P2}$  for  $0 \leq l < N_{P2}$ ;
- $0 \leq p < C_{data}$  for  $N_{P2} \leq l < L_F - 1$ ;
- $0 \leq p < N_{FC}$  for  $l = L_F - 1$  when there is a frame closing symbol;
- $0 \leq p < C_{data}$  for  $l = L_F - 1$  when there is no frame closing symbol.

**Table 47: Number of available data cells  $C_{P2}$  in one P2 symbol**

FFT Size	$C_{P2}$	
	SISO	MISO
1K	558	546
2K	1 118	1 098
4K	2 236	2 198
8K	4 472	4 398
16K	8 944	8 814
32K	22 432	17 612

**Table 48: Number of available data cells  $C_{data}$  in one normal symbol**

FFT Size	Cdata (no tone reservation)								TR cells	
	PP1	PP2	PP3	PP4	PP5	PP6	PP7	PP8		
1K	764	768	798	804	818				10	
2K	1 522	1 532	1 596	1 602	1 632		1 646		18	
4K	3 084	3 092	3 228	3 234	3 298		3 328		36	
8K	Normal	6 208	6 214	6 494	6 498	6 634		6 698	6 698	72
	Extended	6 296	6 298	6 584	6 588	6 728		6 788	6 788	72
16K	Normal	12 418	12 436	12 988	13 002	13 272	13 288	13 416	13 406	144
	Extended	12 678	12 698	13 262	13 276	13 552	13 568	13 698	13 688	144
32K	Normal		24 886		26 022		26 592	26 836	26 812	288
	Extended		25 412		26 572		27 152	27 404	27 376	288

NOTE: An empty entry indicates that the corresponding combination of FFT size and pilot pattern is never used.

**Table 49: Number of data cells  $N_{FC}$  in the frame closing symbol**

FFT Size	$N_{FC}$ for frame closing symbol (no tone reservation)								TR cells
	PP1	PP2	PP3	PP4	PP5	PP6	PP7	PP8	
1K	568	710	710	780	780				10
2K	1 136	1 420	1 420	1 562	1 562		1 632		18
4K	2 272	2 840	2 840	3 124	3 124		3 266		36
8K	Normal	4 544	5 680	5 680	6 248	6 248		6 532	72
	Extended	4 608	5 760	5 760	6 336	6 336		6 624	72
16K	Normal	9 088	11 360	11 360	12 496	12 496	13 064	13 064	144
	Extended	9 280	11 600	11 600	12 760	12 760	13 340	13 340	144
32K	Normal		22 720		24 992		26 128		288
	Extended		23 200		25 520		26 680		288

NOTE: An empty entry indicates that frame closing symbols are never used for the corresponding combination of FFT size and pilot pattern.



**Table 50: Number of available active cells  $C_{FC}$  in the frame closing symbol**

FFT Size	$C_{FC}$ (no tone reservation)								TR cells
	PP1	PP2	PP3	PP4	PP5	PP6	PP7	PP8	
1K	402	654	490	707	544				10
2K	804	1 309	980	1 415	1 088		1 396		18
4K	1 609	2 619	1 961	2 831	2 177		2 792		36
8K	Normal	3 218	5 238	3 922	5 662	4 354		5 585	72
	Extended	3 264	5 312	3 978	5 742	4 416		5 664	72
16K	Normal	6 437	10 476	7 845	11324	8 709	11 801	11 170	144
	Extended	6 573	10 697	8 011	11563	8 893	12 051	11 406	144
32K	Normal		20 952		22649		23 603		288
	Extended		21 395		23127		24 102		288

NOTE: An empty entry indicates that frame closing symbols are never used for the corresponding combination of FFT size and pilot pattern.

Thus, the number of active OFDM cells in one T2-frame ( $C_{tot}$ ) depends on the frame structure parameters including whether or not there is a frame closing symbol (see clause 9.2.7) and is given by:

$$C_{tot} = \begin{cases} N_{P2} * C_{P2} + (L_{data} - 1) * C_{data} + C_{FC} & \text{when there is a frame closing symbol} \\ N_{P2} * C_{P2} + L_{data} * C_{data} & \text{when there is no frame closing symbol} \end{cases}$$

The number of P2 symbols  $N_{P2}$  is dependent on the used FFT size and is defined in table 51.

**Table 51: Number of P2 symbols denoted by  $N_{P2}$  for different FFT modes**

FFT size	$N_{P2}$
1k	16
2k	8
4k	4
8k	2
16k	1
32k	1

The number of OFDM cells needed to carry all L1 signalling is denoted by  $D_{L1}$ . The number of OFDM cells available for transmission of PLPs in one T2-frame is given by:

$$D_{PLP} = C_{tot} - D_{L1} - D_{BC} \quad \text{where}$$

$$D_{BC} = \begin{cases} 0 & \text{if } N_{biasCellsActive} = 0 \\ C_{P2} N_{P2} - D_{L1} - \left( C_{P2} - \frac{D_{L1}}{N_{P2}} - N_{biasCellsActive} \right) & \text{otherwise} \end{cases}$$

$D_{BC}$  is the number of cells occupied by bias balancing cells and the associated dummy cells (see clause 8.3.6.3.1).

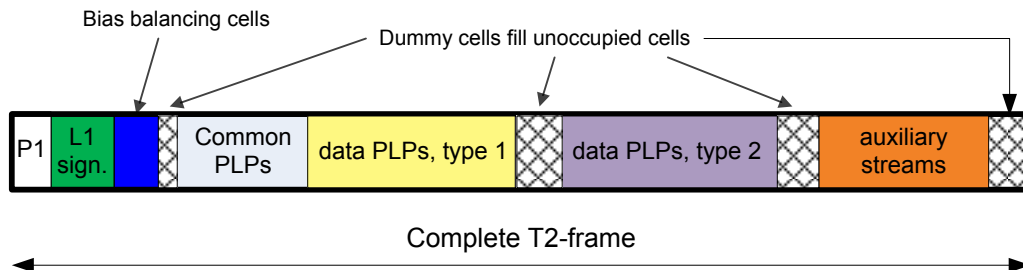
The values of  $D_{BC}$ ,  $D_{L1}$  and  $D_{PLP}$  do not change between T2-frames but may change between super-frames.

All cells  $D_{L1}$  are mapped into P2 symbol(s) as described in clause 8.3.5. The bias balancing cells (if any), the common PLPs and data PLPs are mapped onto the remaining active OFDM cells of the P2 symbol(s) (if any) and the data symbols. The mapping of L1 data is described in clause 8.3.5 and the mapping of the bias balancing cells, common PLPs and data PLPs is described in clause 8.3.6.

A data PLP is carried in sub-slices, where the number of sub-slices is between 1 and 6 480. The data PLPs of type 1 are carried in one sub-slice per T2-frame and the data PLPs of type 2 are carried in between 2 and 6 480 sub-slices. The number of sub-slices is the same for all PLPs of type 2. The number of OFDM cells allocated to data PLPs of type 2 in one T2-frame must be a multiple of  $N_{sublices}$ . The structure of the T2-frame is depicted in figure 37.

Following the data PLPs of type 2 there may be one or more auxiliary streams (see clause 8.3.7) which can be followed by dummy cells. Together, the auxiliary streams and dummy cells exactly fill the remaining capacity of the T2-frame.

The total number of cells used for auxiliary streams and dummy cells shall not exceed 50 % of  $C_{tot}$ .

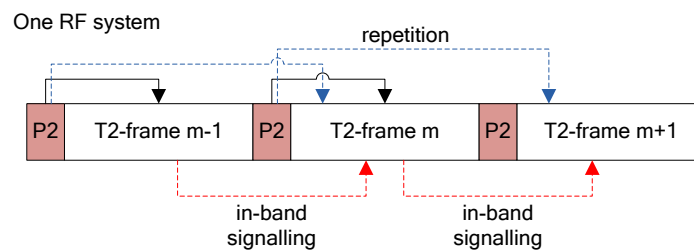


**Figure 37: Structure of the T2-frame**

### 8.3.3 Signalling of the T2-frame structure and PLPs

The configuration of the T2-frame structure is signalled by the L1-pre and L1-post signalling (see clause 7.2). The locations of the PLPs themselves within the T2-frame can change dynamically from T2-frame to T2-frame, and this is signalled both in the dynamic part of the L1-post signalling in P2 (see clause 7.2.3.2), and in the in-band signalling (see clause 5.2.3). Repetition of the dynamic part of the L1-post signalling may be used to improve robustness, as described in clause 7.2.3.3.

In a system with one RF channel, the L1-post dynamic signalling transmitted in P2 refers to the current T2-frame (and the next T2-frame when repetition is used, see clause 7.2.3.3) and the in-band signalling refers to the next Interleaving Frame. This is depicted in figure 38. In a TFS system the L1-post dynamic signalling transmitted in P2 refers to the next T2-frame and the in-band signalling refers to the next-but-one Interleaving Frame, as described in annex E. When the Interleaving Frame is spread over more than one T2-frame, the in-band signalling carries the dynamic signalling for each T2-frame of the next Interleaving Frame, as described in clause 5.2.3.



**Figure 38: L1 signalling for a single RF system**

### 8.3.4 Overview of the T2-frame mapping

The slices and sub-slices of the PLPs, the auxiliary streams and dummy cells are mapped into the symbols of the T2-frame as illustrated in figure 39. The T2-frame starts with a P1 symbol followed by  $N_{p2}$  P2 symbols. The L1-pre and L1-post signalling are first mapped into P2 symbol(s) (see clause 8.3.5). After that, the common PLPs are mapped right after the L1 signalling. The data PLPs follow the common PLPs starting with type 1 PLP1. The type 2 PLPs follow the type 1 PLPs. The auxiliary stream or streams, if any, follow the type 2 PLPs, and this can be followed by dummy cells. Together, the PLPs, auxiliary streams and dummy data cells shall exactly fill the remaining cells in the frame.

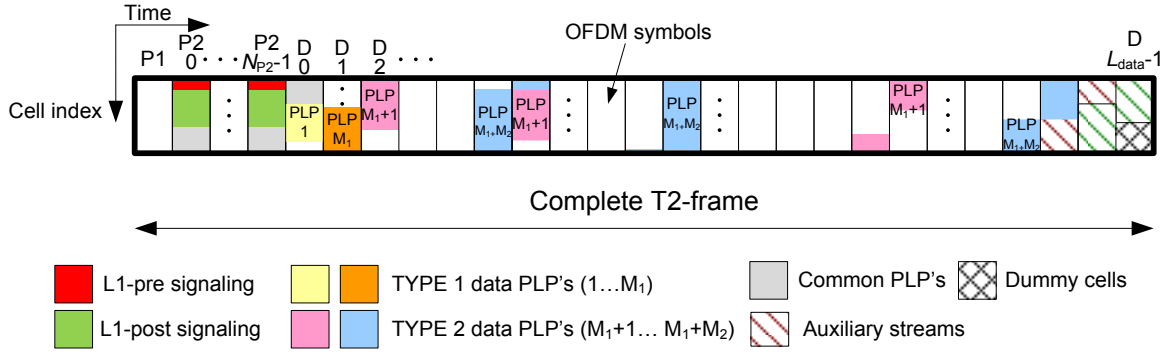


Figure 39: Mapping of data PLPs into the data symbols

### 8.3.5 Mapping of L1 signalling information to P2 symbol(s)

Coded and modulated L1-pre and L1-post cells for T2-frame  $m$  are mapped to the P2 symbol(s) as follows:

- 1) L1-pre cells are mapped to the active cells of P2 symbol(s) in row-wise zig-zag manner as illustrated in figure 40 by the blue blocks and described in the following equation:

$$x_{m,l,p} = f'_{pre}{}_{m,p \times N_{P2} + l}, \text{ for } 0 \leq l < N_{P2} \text{ and } 0 \leq p < \frac{D_{L1pre}}{N_{P2}},$$

where:  $f'_{pre}{}_{m,i}$  are the modulated L1-pre cells after modification by the L1-ACE algorithm (see clause 7.3.3.3)

$D_{L1pre}$  is the number of L1-pre cells per T2-frame,  $D_{L1pre} = 1840$ ;

$N_{P2}$  is the number of P2 symbols as shown in table 51; and

$x_{m,l,p}$  are the active cells of each OFDM symbol as defined in clause 8.3.2.

- 2) L1-post cells are mapped to the active cells of the P2 symbol(s) after the L1-pre cells in row-wise zig-zag manner as shown by the green blocks in figure 40 and described in the following equation:

$$x_{m,l,p + \frac{D_{L1pre}}{N_{P2}}} = f'_{post}{}_{m,p \times N_{P2} + l}, \text{ for } 0 \leq l < N_{P2} \text{ and } 0 \leq p < \frac{D_{L1post}}{N_{P2}}$$

where:  $f'_{post}{}_{m,i}$  are the modulated L1-post cells after modification by the L1-ACE algorithm (see clause 7.3.3.3)

$D_{L1post}$  is the number of L1-post cells per T2-frame,  $D_{L1post} = N_{MOD\_Total}$

NOTE: The zig-zag writing may be implemented by the time interleavers presented in figure 41. The data is written to the interleaver column-wise, while the read operation performs row-wise. The number of rows in the interleaver is equal to  $N_{P2}$ . The number of columns depends on the amount of data to be interleaved and is equal to  $D_{L1pre}/N_{P2}$  and  $D_{L1post}/N_{P2}$  respectively.

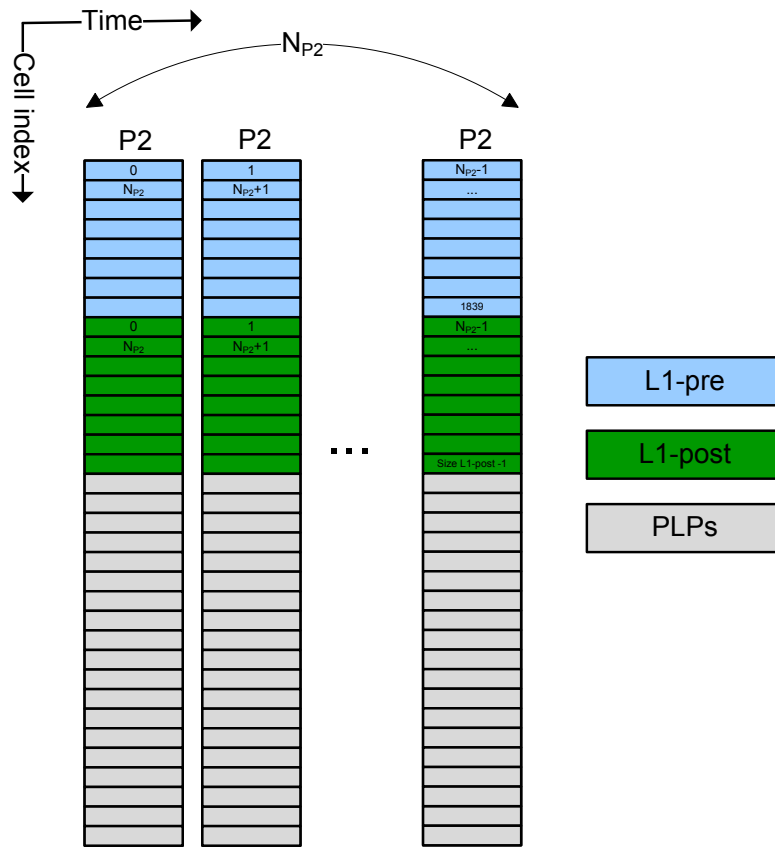
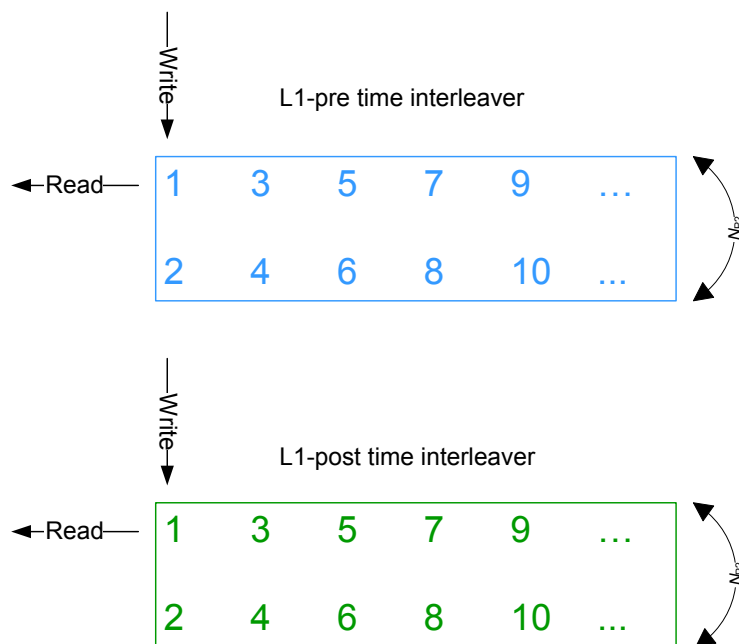


Figure 40: Mapping of L1 data into P2 symbol(s), showing the index of the cells within the L1-pre and L1-post data fields



NOTE: The number of rows is equal to  $N_{P2}$ .

Figure 41: P2 time interleaver

### 8.3.6 Mapping the PLPs

After the L1 data has been mapped to the P2 symbol(s), bias balancing cells may be added, and the remaining active data cells  $x_{m,l,p}$  in the P2 symbol(s) and data symbols are available for PLPs.

PLPs are classified into 3 types, signalled in L1-post signalling field PLP\_TYPE; common PLP, data PLP Type 1 and data PLP type 2. Common and Type 1 PLPs have exactly one sub-slice per T2-frame, whereas type 2 PLPs have between 2 and 6 480 sub-slices per T2-frame.

The common PLPs are transmitted at the beginning of the T2-frame, after the L1 signalling and bias balancing cells (if any). Data PLPs of type 1 are transmitted after the common PLPs. Data PLPs of type 2 are transmitted after the data PLPs of type 1.

#### 8.3.6.1 Allocating the cells of the Interleaving Frames to the T2-Frames

If the Interleaving Frame for a given PLP is mapped directly to one T2-Frame (see clause 6.5), then the cells to be allocated to the T2-frame shall be all of the cells of the corresponding Interleaving Frame from the output of the Time Interleaver.

In general the Interleaving Frame for PLP  $i$  will be mapped to  $P_1(i)$  T2-frames (see clause 6.5.1), and the Interleaving Frame shall be divided into  $P_1(i)$  slices, each containing an equal number of cells  $D_i$  given by:

$$D_i = \frac{N_{BLOCKS\_IF}(i, n) \times N_{LDPC}(i)}{P_1(i) \times \eta_{MOD}(i)}$$

where  $N_{BLOCKS\_IF}(i, n)$  is the number of LDPC blocks  $N_{BLOCKS\_IF}(n)$  in the current Interleaving Frame (index  $n$ ) for PLP  $i$ ;  $N_{ldpc}(i)$  is the LDPC block length and  $\eta_{MOD}(i)$  is the number of bits per cell for PLP  $i$ .  $N_{BLOCKS\_IF}(n)$  was defined in clause 6.5 for the Time Interleaver.

The values of  $P_1(i)$  shall be chosen such that  $\frac{N_{LDPC}(i)}{P_1(i) \times \eta_{MOD}(i)}$  is an integer for all PLPs. Further restrictions apply for Type 2 PLPs, see clause 8.3.6.3.3.

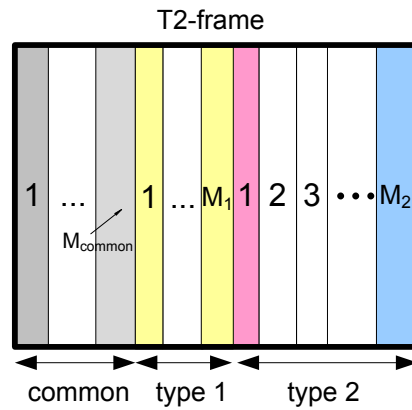
The first  $D_i$  cells shall be allocated to the first T2-frame to which the Interleaving Frame is mapped, the next  $D_i$  cells to the next T2-frame to which the Interleaving Frame is mapped, and so on for each T2-frame to which the Interleaving Frame is mapped. Clause 8.2 describes how to determine the T2-frames to which a given PLP is mapped, which will not be successive T2-frames if a frame interval ( $I_{JUMP}$ ) value greater than 1 is used.

Figure 42 depicts the OFDM cells for data PLPs of a T2-frame.  $M_{common}$  common PLPs,  $M_1$  PLPs of type 1 and  $M_2$  PLPs of type 2 are carried in the frame.

The scheduler shall allocate values for  $N_{BLOCKS\_IF}(i, n)$  for each Interleaving Frame for each PLP such that the total number of cells of all PLPs plus any auxiliary streams (see clause 8.3.7) shall not exceed the number of cells reserved for data. Hence the  $N_{BLOCKS\_IF}(i, n)$  shall be allocated such that the resulting values  $D_i$  satisfy the following:

$$\sum_{i=1}^{M_{common}} D_{i,common} + \sum_{i=1}^{M_1} D_{i,1} + \sum_{i=1}^{M_2} D_{i,2} + \sum_{i=1}^{M_{AUX}} D_{i,aux} \leq D_{PLP}$$

where  $D_{i,common}$  is the number of OFDM cells  $D_i$  needed for carrying the common PLP index  $i$ ,  $D_{i,j}$  is the number of OFDM cells  $D_i$  needed for carrying the data PLP  $i$  of type  $j$ ,  $M_{aux}$  is the number of auxiliary streams, and  $D_{i,aux}$  is the number of cells occupied by auxiliary stream  $i$ .



**Figure 42: Allocation of  $M_{\text{common}}$  common PLPs,  $M_1$  data PLPs of type1 and  $M_2$  data PLPs of type 2 transmitted in one T2-frame**

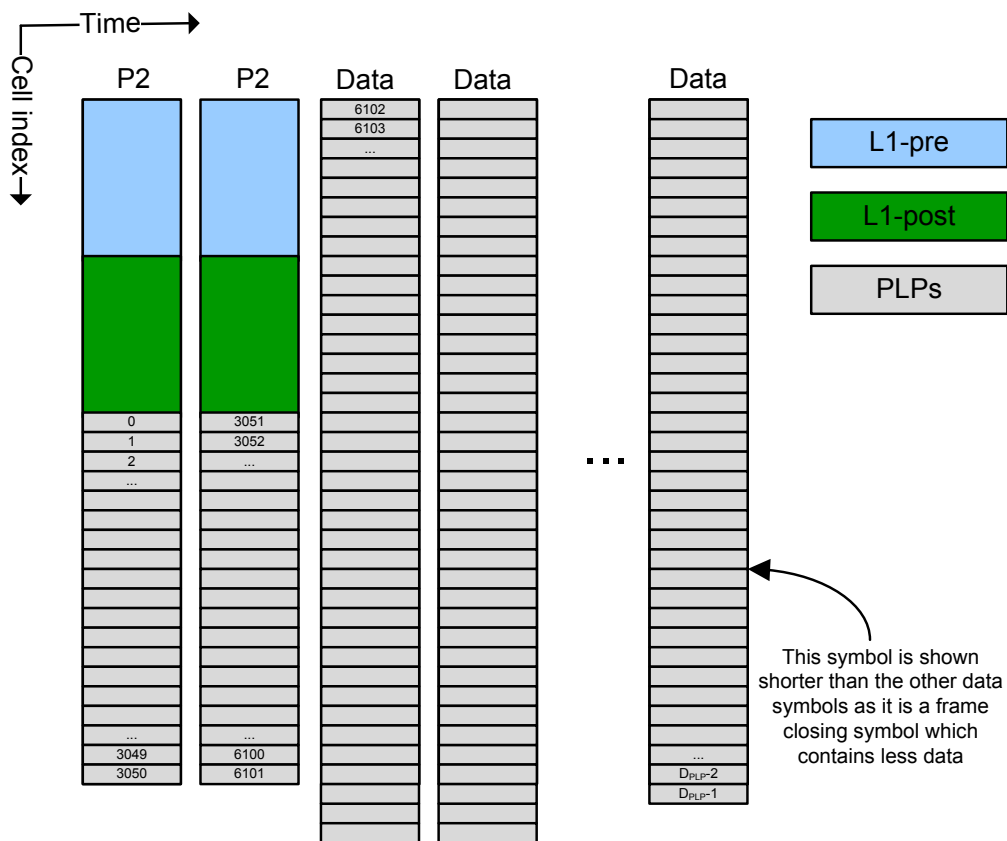
### 8.3.6.2 Addressing of OFDM cells

A one-dimensional addressing scheme ( $0..D_{\text{PLP}}-1$ ) is defined for the active data cells that are not used for L1 signalling. The addressing scheme defines the order in which the cells from the sub-slices of the PLPs are allocated to the active data cells, and is also used to signal the locations of the sub-slices of all PLPs in the dynamic part of the L1-post signalling. The addressing scheme also defines the order of all of the other cells (i.e. bias balancing cells, the cells of the auxiliary streams and the dummy cells).

Address 0 shall refer to the cell  $x_{m,0,\frac{D_{L1}}{N_{P2}}}$ , the cell immediately following the last cell carrying L1-post signalling in the first P2 symbol. The addresses 0,1,2, ... shall refer to the cells in the following sequence:

- $x_{m,l,\frac{D_{L1}}{N_{P2}}} \dots x_{m,l,C_{P2}-1}$  for each  $l=0 \dots N_{P2}-1$ , followed by
- $x_{m,l,0} \dots x_{m,l,C_{\text{data}}-1}$  for each  $l=N_{P2} \dots L_F-2$ , followed by
- $x_{m,L_F-1,0} \dots x_{m,L_F-1,C_{FC}-1}$  if there is a frame closing symbol; or
- $x_{m,L_F-1,0} \dots x_{m,L_F-1,C_{\text{data}}-1}$  if there is no frame closing symbol.

The location addresses are depicted in figure 43.



**Figure 43: Addressing of the OFDM cells for common PLPs and data PLPs**  
The numbers (cell addresses) are exemplary

### 8.3.6.3 Mapping the PLPs to the data cell addresses

The allocation of slices and subslices to the T2-frames is done by the scheduler. The scheduler may use any method to perform the allocation and may map the PLPs to the T2-frame in any order, provided the requirements in the following clauses are met and also that the locations of the cells of the PLPs are as described by the L1 signalling, interpreted as described in the following clauses.

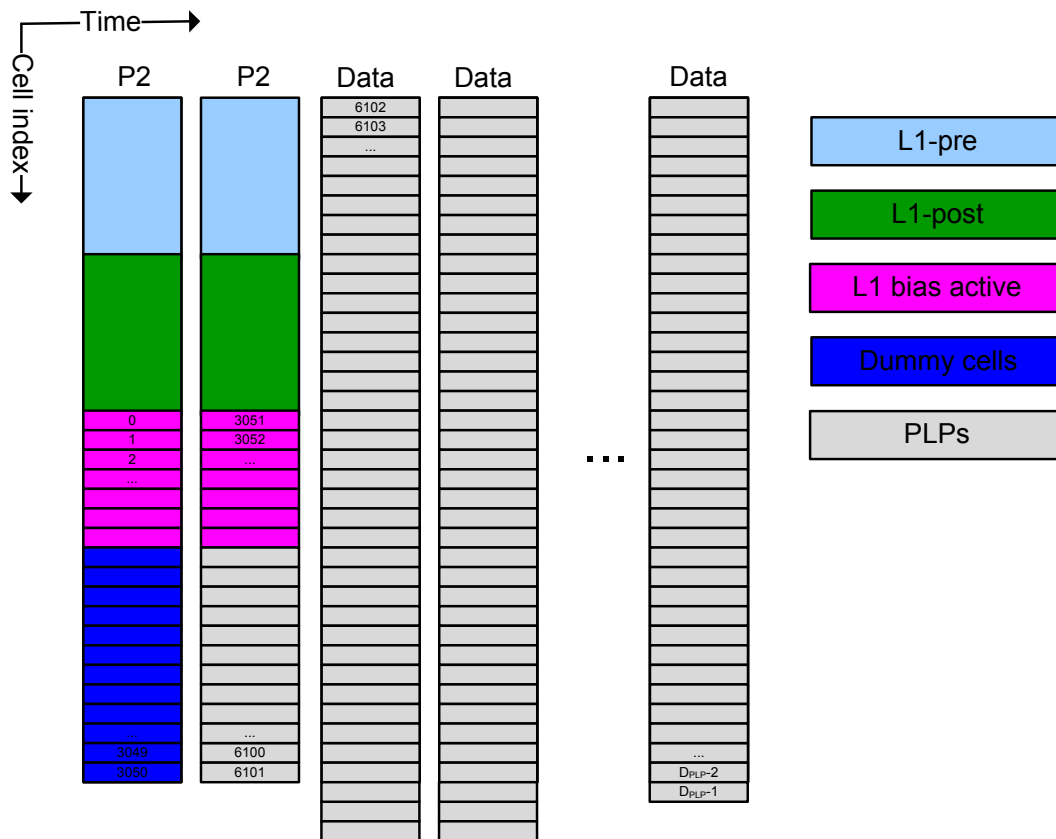
**NOTE:** If it is required that several modulators produce identical output given the same input, for example when operating in a single frequency network, it will be necessary to define the mapping in a single scheduler located in a centralised place, such as a T2-gateway (see the note in clause 4.2). The individual modulators can then all produce an identical mapping.

Since the number of cells needed to carry all of the data may be less than the number of available cells ( $D_{PLP}$ ), some cells may remain unallocated for data. These unallocated cells are dummy cells, and shall be set as described by clause 8.3.8.

#### 8.3.6.3.1 Insertion of bias balancing cells

If the bias balancing bits (see clause 7.2.3.7) were insufficient to completely balance the bias in the L1 signalling, a peak may result in the time domain signal of the P2 symbols. If the limits on the tone reservation PAPR reduction algorithm (see clause 9.6.2) mean that it will be unable to reduce this peak to an acceptable level, bias balancing cells may also be inserted into the P2 symbols, according to this clause, to further reduce the peak.

The bias balancing cells, if any, are inserted evenly into the P2 symbols, so that the same number of active bias balancing cells,  $N_{\text{biasCellsActive}}$ , is inserted into each P2 symbol. For compatibility with previous versions of the present document, the cells of the PLPs shall not start until after the bias balancing cell with the highest numbered cell address, as shown in figure 44. If bias balancing cells are being inserted, but they do not completely fill the P2 symbols, the unoccupied cells of the first  $N_{P2}-1$  P2 symbols shall be filled with dummy cells. Hence the use of this technique is most efficient when the L1-signalling fills a significant proportion of the P2 symbols.



**Figure 44: Illustration of the use of bias balancing cells**

The modulation that shall be applied to the bias balancing cells in a given T2-frame depends on the residual bias of the modulated L1 signalling cells of the same T2-frame after modification by the L1-ACE algorithm (see clause 7.3.3.3).

The residual bias of the L1 for T2-frame  $m$  is given by  $C'_{\text{bias}}(m)$ , where:

$$C'_{\text{bias}}(m) = \sum_{l=0}^{N_{P2}-1} \sum_{p=0}^{D_{L1}-1} x_{m,l,p}$$

The bias balancing cells shall be set to a value  $C_{\text{bal}}(m)$ :

$$x_{m,l,p} = C_{\text{bal}}(m), \quad 0 \leq l < N_{P2} \text{ and } \frac{D_{L1}}{N_{P2}} \leq p < \frac{D_{L1}}{N_{P2}} + N_{\text{biasCellsActive}},$$

where the desired value to approximately balance the bias is  $C'_{\text{bal}}(m)$ , and:

$$C'_{\text{bal}}(m) = \frac{-C'_{\text{bias}}(m)}{N_{P2}N_{\text{biasCellsActive}}} \quad \text{and}$$

$$C_{\text{bal}}(m) = \begin{cases} C'_{\text{bal}}(m) & \text{if } |C'_{\text{bal}}| \leq 1 \\ \frac{C'_{\text{bal}}(m)}{|C'_{\text{bal}}(m)|} & \text{otherwise} \end{cases}$$



### 8.3.6.3.2 Mapping the Common and Type 1 PLPs

The cells of the Common PLPs, if any, shall be mapped into the first part of the frame (i.e. they shall have lower cell addresses than for the other types of PLP), but shall always be after the bias balancing cells, if any. The cells of any one Common PLP for a particular T2-frame shall be mapped sequentially into a single contiguous range of cell addresses of the frame, in order of increasing address.

Although the present document specifies that the mapping shall be done in the way described above, this method shall not be assumed by the receiver, but instead the signalled addressing scheme shall be followed. This will allow future versions of the present document to use different methods, without requiring changes to receivers.

In the case of TFS each Common PLP shall be sent on all RF frequencies with identical scheduling in a T2-frame (see annex E).

The cells of a Type 1 PLP for a particular T2-frame shall also be mapped sequentially into a single contiguous range of cell addresses of the frame, in order of increasing address. The cells of all the Type 1 PLPs shall follow after the common PLPs, if any, and before any Type 2 PLPs or auxiliary streams, if any.

The addressing of the Common and Type 1 PLPs is given by L1-post signalling, see clause 7.2.3.

The address of the first cell of a common or Type 1 PLP, *slice\_start*, shall be signalled directly by the *PLP\_START* field of the dynamic L1 signalling.

The address of the last cell, '*slice\_end*', occupied by a common or Type 1 PLP, shall be calculated as follows:

$$\text{slice\_end} = \text{PLP\_START} + \frac{\text{PLP\_NUM\_BLOCKS} \times N_{\text{cells}}}{P_I} - 1$$

where  $N_{\text{cells}}$  is the number of OFDM cells in an LDPC block as given in table 17 and  $P_I$  is the number of T2-frames to which an Interleaving Frame is mapped. *PLP\_START* and *PLP\_NUM\_BLOCKS* are defined in clause 7.2.3.2.

### 8.3.6.3.3 Mapping the Type 2 PLPs

The cells of each Type 2 PLP that are allocated to a particular T2-frame shall be divided into  $N_{\text{sub-slices}}$  sub-slices, where  $N_{\text{sub-slices}}$  (in the non-TFS case) is equal to  $N_{\text{sub-slices\_total}}$ , signalled by *SUB\_SLICES\_PER\_FRAME* in the L1 configurable signalling.

The number of sub-slices per T2-frame,  $N_{\text{sub-slices}}$ , the number of T2-frames  $P_I(i)$  to which each Interleaving Frame for PLP  $i$  is mapped, (and also the number  $N_{RF}$  of channels when TFS is applied, see annex E) shall comply with the following limitation:

$$N_{\text{CELLS}}(i) \bmod \{5 \cdot N_{\text{sub-slices\_total}} \cdot P_I(i)\} = 0, \text{ for all } i \in \{1..M_2\}$$

where  $N_{\text{sub-slices\_total}} = N_{RF} \times N_{\text{sub-slices}}$ ,  $M_2$  is the number of type 2 PLPs and  $N_{\text{CELLS}}(i)$  is the number of cells in one FEC block for PLP  $i$ . This shall be achieved by a suitable choice of  $N_{\text{sub-slices}}$  and  $P_I$  given the FEC block sizes and modulation types in use. Suitable values for  $N_{\text{sub-slices\_total}}$  for the case where the Interleaving Frame is mapped to one T2-frame for all the PLPs ( $P_I=1$ ), are listed in annex L.

Each of the sub-slices of any one PLP shall contain an equal number of cells  $D_{i,2}/N_{\text{sub-slices}}$ , where  $D_{i,2}$  is the number of cells in the T2-frame for PLP  $i$  of Type 2 and is defined in clause 8.3.6.1. The first sub-slice shall contain the first  $D_{i,2}/N_{\text{sub-slices}}$  cells, the second sub-slice shall contain the next  $D_{i,2}/N_{\text{sub-slices}}$  cells, and so on for each sub-slice.

NOTE 1: The number of OFDM cells for each PLP,  $D_{i,2}$ , may be different, but every  $D_{i,2}$  will be a multiple of  $N_{\text{sub-slices}}$ , so that all sub-slices carrying the same PLP have equal size. This is guaranteed if the above (more restrictive) limitation is met.

Each sub-slice of a PLP shall be mapped to a contiguous range of cell addresses of the frame, in order of increasing address. The cells of the first sub-slice of the first Type 2 PLP shall start after the last cell of the last Type 1 PLP. These shall be followed by the cells of the first sub-slice of the other Type 2 PLPs, followed by the cells of the second sub-slice for each PLP in turn, with the PLPs taken in the same order, and so on until the last sub-slice of the last PLP has been mapped.

Although the present document specifies that the mapping shall be done in the way described above, this method shall not be assumed by the receiver, but instead the signalled addressing scheme shall be followed. This will allow future versions of the present document to use different methods, without requiring changes to receivers.

The address of the first cell of the first sub-slice of a PLP is indicated by the PLP\_START field of the dynamic L1 signalling. The length of the sub-slice in OFDM cells can be calculated directly from the fields PLP\_NUM\_BLOCKS and SUB\_SLICES\_PER\_FRAME, together with  $P_1$ , which is signalled by TIME\_IL\_LENGTH in conjunction with TIME\_IL\_TYPE. The start address of the subsequent sub-slices can be calculated from the PLP\_START and SUB\_SLICE\_INTERVAL fields. The signalling fields are described in detail in clause 7.2.

The address of the first and last cell for the sub-slice  $j$  of a type 2 data PLP are given by:

$$\text{Sub\_slice\_start}(j) = \text{PLP\_START} + j \times \text{SUB\_SLICE\_INTERVAL}$$

$$\text{Sub\_slice\_end}(j) = \text{Sub\_slice\_start}(j) + \frac{\text{PLP\_NUM\_BLOCKS} \times N_{\text{cells}}}{N_{\text{subslices}} \times P_1} - 1.$$

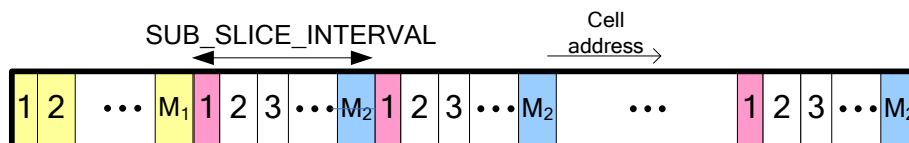
for  $j=0, 1, \dots, N_{\text{subslices}}-1$ . Here  $N_{\text{subslices}} = \text{SUB\_SLICES\_PER\_FRAME}$  and  $N_{\text{cells}}$  is the number of OFDM cells in an LDPC block as given in table 17 and  $P_1$  is the number of T2-frames to which an Interleaving Frame is mapped. PLP\_START, SUB\_SLICE\_INTERVAL, and PLP\_NUM\_BLOCKS are defined in clause 7.2.3.2.

NOTE 2: SUB\_SLICE\_INTERVAL is the difference in cell address between the first cell of one sub-slice and the first cell of the next sub-slice for a given PLP, and is given by:

$$\text{SUB\_SLICE\_INTERVAL} = \frac{\sum_{i=1}^{M_2} D_{i,2}}{N_{\text{subslices}}}$$

A receiver shall not assume that SUB\_SLICE\_INTERVAL can be calculated as described in the note above, but instead shall use the signalled value (see clause 7.2.3.2).

The allocation of the  $M_1$  Type 1 and  $M_2$  Type 2 PLPs to the cell addresses of the T2-frame is illustrated in figure 45.



**Figure 45: Scheduled data PLPs for T2-frame**

EXAMPLE: The first four symbols in a T2-frame have the structure presented in figure 43. The frame carries one common PLP, followed by data PLPs. The common PLP is carried in one 16 200 bit LDPC block in the current frame. The modulation used for the common PLP is 64-QAM, thus 2 700 cells are needed to carry 16 200 bits. The PLP loop in the dynamic L1-post signalling is as follows:

- PLP\_ID=0; PLP\_START = 0; PLP\_NUM\_BLOCKS = 1;
- PLP\_ID=1; PLP\_START = 2700; etc.

The first row describes the signalling for the common PLP and the second row the signalling for the first data PLP.

### 8.3.7 Auxiliary stream insertion

Following the Type 2 PLPs, one or more auxiliary streams may be added. Each auxiliary stream consists of a sequence of  $D_{i,\text{aux}}$  cell values  $x_{m,l,p}$  in each T2-frame, where  $i$  is the auxiliary stream index. The cell values shall have the same mean power as the data cells of the data PLPs, i.e.  $E(x_{m,l,p} \cdot x_{m,l,p}^*) = 1$ , but apart from this restriction they may be used as required by the broadcaster or network operator. The auxiliary streams are mapped one after another onto the cells in order of increasing cell address, starting after the last cell of the last sub-slice of the last Type 2 PLP.

The start position and number of cells  $D_{i,\text{aux}}$  for each auxiliary stream may vary from T2-frame to T2-frame, and bits are reserved to signal these parameters in the L1 dynamic signalling.

The cell values for auxiliary streams need not be the same for all transmitters in a single frequency network. However, if MISO is used as described in clause 9.1, care shall be taken to ensure that the auxiliary streams do not interfere with the correct decoding of the data PLPs. If auxiliary streams are used that are different between the transmitters of a single frequency network, it is recommended that Active Constellation Extension (see clause 9.6.1) should not be used, unless steps are taken to ensure that the same modifications are applied to each data cell from each transmitter.

The cells of an auxiliary stream with AUX\_STREAM\_TYPE '0000' (see clause 7.2.3.1), when MISO mode is also being used, shall be mapped such that none of the relevant auxiliary stream cells occupy the same symbol as any cells of data PLPs. In this case, the MISO processing (see clause 9.1) shall not be applied to the symbols occupied by the relevant auxiliary stream cells. However, the modifications of the pilots for MISO (see clause 9.2.8) shall still be applied to these symbols.

Specific uses of auxiliary streams, including coding and modulation, will be defined either in future editions of the present document or elsewhere. The auxiliary streams may be ignored by the receiver. If the number of auxiliary streams is signalled as zero, this clause is ignored.

### 8.3.8 Dummy cell insertion

If the L1 signalling, bias balancing cells, PLPs and auxiliary streams do not exactly fill the  $C_{\text{tot}}$  active cells in one T2-frame, dummy cells shall be inserted in the remaining  $N_{\text{dummy}}$  cells (see clause 8.3.6.3), where:

$$N_{\text{dummy}} = D_{\text{plp}} - \left( N_{\text{biasCellsActive}} N_{\text{P2}} + \sum_{i=1}^{M_{\text{common}}} D_{i,\text{common}} + \sum_{i=1}^{M_1} D_{i,1} + \sum_{i=1}^{M_2} D_{i,2} + \sum_{i=1}^{M_{\text{AUX}}} D_{i,\text{aux}} \right)$$

The dummy cell values are generated by taking the first  $N_{\text{dummy}}$  values of the BB scrambling sequence defined in clause 5.2.4. The sequence is reset at the beginning of the dummy cells of each T2-frame. The resulting bits  $b_{\text{BS},j}$ ,  $0 \leq j < N_{\text{dummy}}$ , are then mapped to cell values  $x_{m,l,p}$  according to the following rule:

$$\text{Re}\{x_{m,l,p}\} = 2 (1/2 - b_{\text{BS},j})$$

$$\text{Im}\{x_{m,l,p}\} = 0,$$

where the bits  $b_{\text{BS},j}$  are mapped to cells  $x_{m,l,p}$  in order of increasing cell address starting from the first unallocated address.

### 8.3.9 Insertion of unmodulated cells in the Frame Closing Symbol

When a frame closing symbol is used (see clauses 8.3.2 and 9.2.7), some of its data cells carry no modulation in order to maintain constant symbol power in the presence of a higher pilot density.

The last  $N_{\text{FC}} - C_{\text{FC}}$  cells of the Frame Closing Symbol,  $(x_{m, \text{LF}-1, \text{CFC}} \dots x_{m, \text{LF}-1, \text{NFC}-1})$ , shall all be set to  $0+j0$ .

## 8.4 Future Extension Frames (FEF)

Future Extension Frame (FEF) insertion enables carriage of frames defined in a future extension of the DVB-T2 standard in the same multiplex as regular T2-frames. The use of future extension frames is optional.

A future extension frame may carry data in way unknown to a DVB-T2 receiver addressing the current standard version. A receiver addressing the current standard version is not expected to decode future extension frames. All receivers are expected to detect FEF parts.

A FEF part shall begin with a P1 symbol that can be detected by all DVB-T2 receivers. The maximum length of a FEF part is 250 ms for the T2-base profile and 1s for the T2-Lite profile (see annex I). All other parts of the future extension frames will be defined in future extensions of the present document or elsewhere.

The FEF parts of one profile may contain frames of other profiles and/or non-T2 signals. Since each FEF part may contain multiple frames of other profiles, each FEF part may also have several P1 symbols, at varying intervals throughout its length. The minimum interval between two P1 symbols shall be  $10\,000T$ , where  $T$  is the elementary period (see clause 9.5). NOTE: This minimum interval between P1 symbols (which is approximately 1.1ms for 8MHz bandwidth) allows a receiver to determine the frame start positions correctly in the presence of long echoes. In this case, the receiver synchronisation circuitry may 'see' P1 symbols separated by the echo delay, but this delay could never be expected to exceed about  $4\,900T$ . So P1 symbols apparently separated by less than  $5\,000T$  can be assumed to be due to the effect of echoes, whereas a separation of more than  $5\,000T$  can be assumed to be due to independent P1 symbols. The constraints on T2-frame lengths mean that their duration will always exceed  $10\,000T$ .

The detection of FEF parts is enabled by the L1 signalling carried in the P2 symbol(s) (see clause 7.2.3.1). The configurable L1 fields signal the size and structure of the super-frame. The NUM\_T2\_FRAMES describes the number of T2-frames carried during one super-frame. The location of the FEF parts is described by the L1 signalling field FEF\_INTERVAL, which is the number of T2-frames at the beginning of a super-frame, before the beginning of the first FEF part. The same field also describes the number of T2-frames between two FEF parts. The length of the FEF part is given by the FEF\_LENGTH field of the L1 signalling. This field describes the time between two DVB-T2 frames preceding and following a FEF part as the number of elementary time periods  $T$ , i.e. samples in the receiver (see clause 9.5).

The parameters affecting the configuration of FEFs shall be chosen to ensure that, if a receiver obeys the TTO signalling (see annex C) and implements the model of buffer management defined in clause C.1.1, the receiver's de-jitter buffer and time de-interleaver memory shall neither overflow nor underflow.

NOTE: In order not to affect the reception of the T2 data signal, it is assumed that the receiver's automatic gain control will be held constant for the duration of FEF part, so that it is not affected by any power variations during the FEF part.

## 8.5 Frequency interleaver

The purpose of the frequency interleaver, operating on the data cells of one OFDM symbol, is to map the data cells from the frame builder onto the  $N_{\text{data}}$  available data carriers in each symbol.  $N_{\text{data}} = C_{\text{P2}}$  for the P2 symbol(s),  $N_{\text{data}} = C_{\text{data}}$  for the normal symbols (see clause 8.3.2), and  $N_{\text{data}} = N_{\text{FC}}$  for the Frame Closing symbol, if present.

For the P2 symbol(s) and all other symbols, the frequency interleaver shall process the data cells  $X_{m,l} = (x_{m,l,0}, x_{m,l,1}, \dots, x_{m,l, N_{\text{data}}-1})$  of the OFDM symbol  $l$  of T2-frame  $m$ , from the frame builder.

Thus for example in the 8k mode with scattered pilot pattern PP7 and no tone reservation, blocks of 6 698 data cells from the frame builder during normal symbols form the input vector  $X_{m,l} = (x_{m,l,0}, x_{m,l,1}, x_{m,l,2}, \dots, x_{m,l,6697})$ .

A parameter  $M_{\text{max}}$  is then defined according to table 52.

**Table 52: Values of  $M_{\text{max}}$  for the frequency interleaver**

FFT Size	$M_{\text{max}}$
1K	1 024
2K	2 048
4K	4 096
8K	8 192
16K	16 384
32K	32 768

The interleaved vector  $A_{m,l} = (a_{m,l,0}, a_{m,l,1}, a_{m,l,2}, \dots, a_{m,l, N_{\text{data}}-1})$  is defined by:

$$a_{m,l,H(p)} = x_{m,l,p} \text{ for even symbols of the frame } (l \bmod 2 = 0) \text{ in mode 32K for } p = 0, \dots, N_{\text{data}}-1.$$

$$a_{m,l,p} = x_{m,l,H(p)} \text{ for odd symbols of the frame } (l \bmod 2 = 1) \text{ in mode 32K for } p = 0, \dots, N_{\text{data}}-1.$$

For other modes: 1K, 2K, 4K, 8K, 16K:

$a_{m,l,p} = x_{m,l,H_0(p)}$  for even symbols of the frame ( $l \bmod 2 = 0$ ) for  $p = 0, \dots, N_{\text{data}} - 1$ ; and

$a_{m,l,p} = x_{m,l,H_1(p)}$  for odd symbols of the frame ( $l \bmod 2 = 1$ ) for  $p = 0, \dots, N_{\text{data}} - 1$ .

$H(p)$ ,  $H_0(p)$  and  $H_1(p)$  are permutation functions based on sequences  $R'_i$  defined by the following.

An  $(N_r - 1)$  bit binary word  $R'_i$  is defined, with  $N_r = \log_2 M_{\text{max}}$ , where  $R'_i$  takes the following values:

$$i = 0, 1: \quad R'_i [N_r - 2, N_r - 3, \dots, 1, 0] = 0, 0, \dots, 0, 0$$

$$i = 2: \quad R'_i [N_r - 2, N_r - 3, \dots, 1, 0] = 0, 0, \dots, 0, 1$$

$$2 < i < M_{\text{max}}: \quad \{ R'_i [N_r - 3, N_r - 4, \dots, 1, 0] = R'_{i-1} [N_r - 2, N_r - 3, \dots, 2, 1];$$

$$\text{in the 1k mode: } R'_i [8] = R'_{i-1} [0] \oplus R'_{i-1} [4]$$

$$\text{in the 2k mode: } R'_i [9] = R'_{i-1} [0] \oplus R'_{i-1} [3]$$

$$\text{in the 4k mode: } R'_i [10] = R'_{i-1} [0] \oplus R'_{i-1} [2]$$

$$\text{in the 8k mode: } R'_i [11] = R'_{i-1} [0] \oplus R'_{i-1} [1] \oplus R'_{i-1} [4] \oplus R'_{i-1} [6]$$

$$\text{in the 16k mode: } R'_i [12] = R'_{i-1} [0] \oplus R'_{i-1} [1] \oplus R'_{i-1} [4] \oplus R'_{i-1} [5] \oplus R'_{i-1} [9] \oplus R'_{i-1} [11]$$

$$\text{in the 32k mode: } R'_i [13] = R'_{i-1} [0] \oplus R'_{i-1} [1] \oplus R'_{i-1} [2] \oplus R'_{i-1} [12] \}$$

A vector  $R_i$  is derived from the vector  $R'_i$  by the bit permutations given in tables 53(a) to 53(f).

**Table 53(a): Bit permutations for the 1k mode**

$R'_i$ bit positions	8	7	6	5	4	3	2	1	0
$R_i$ bit positions ( $H_0$ )	4	3	2	1	0	5	6	7	8
$R_i$ bit positions ( $H_1$ )	3	2	5	0	1	4	7	8	6

**Table 53(b): Bit permutations for the 2k mode**

$R'_i$ bit positions	9	8	7	6	5	4	3	2	1	0
$R_i$ bit positions ( $H_0$ )	0	7	5	1	8	2	6	9	3	4
$R_i$ bit positions ( $H_1$ )	3	2	7	0	1	5	8	4	9	6

**Table 53(c): Bit permutations for the 4k mode**

$R'_i$ bit positions	10	9	8	7	6	5	4	3	2	1	0
$R_i$ bit positions ( $H_0$ )	7	10	5	8	1	2	4	9	0	3	6
$R_i$ bit positions ( $H_1$ )	6	2	7	10	8	0	3	4	1	9	5

**Table 53(d): Bit permutations for the 8k mode**

$R'_i$ bit positions	11	10	9	8	7	6	5	4	3	2	1	0
$R_i$ bit positions ( $H_0$ )	5	11	3	0	10	8	6	9	2	4	1	7
$R_i$ bit positions ( $H_1$ )	8	10	7	6	0	5	2	1	3	9	4	11

**Table 53(e): Bit permutations for the 16k mode**

$R'_i$ bit positions	12	11	10	9	8	7	6	5	4	3	2	1	0
$R_i$ bit positions ( $H_0$ )	8	4	3	2	0	11	1	5	12	10	6	7	9
$R_i$ bit positions ( $H_1$ )	7	9	5	3	11	1	4	0	2	12	10	8	6

**Table 53(f): Bit permutations for the 32k mode**

$R'_i$ bit positions	13	12	11	10	9	8	7	6	5	4	3	2	1	0
$R_i$ bit positions	6	5	0	10	8	1	11	12	2	9	4	3	13	7

The permutation function  $H(p)$  is defined by the following algorithm:

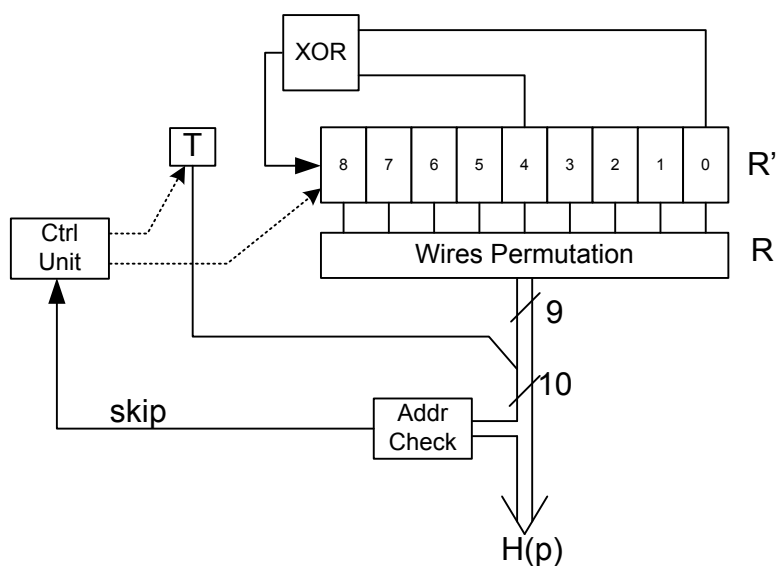
$p = 0$ ;

for ( $i = 0$ ;  $i < M_{\max}$ ;  $i = i + 1$ )

$$\{ H(p) = (i \bmod 2) \cdot 2^{N_r - 1} + \sum_{j=0}^{N_r - 2} R_i(j) \cdot 2^j;$$

if ( $H(p) < N_{\text{data}}$ )  $p = p + 1$ ; }

A schematic block diagram of the algorithm used to generate the permutation function is represented in figures 46(a) to 46(f).

**Figure 46(a): Frequency interleaver address generation scheme for the 1k mode**

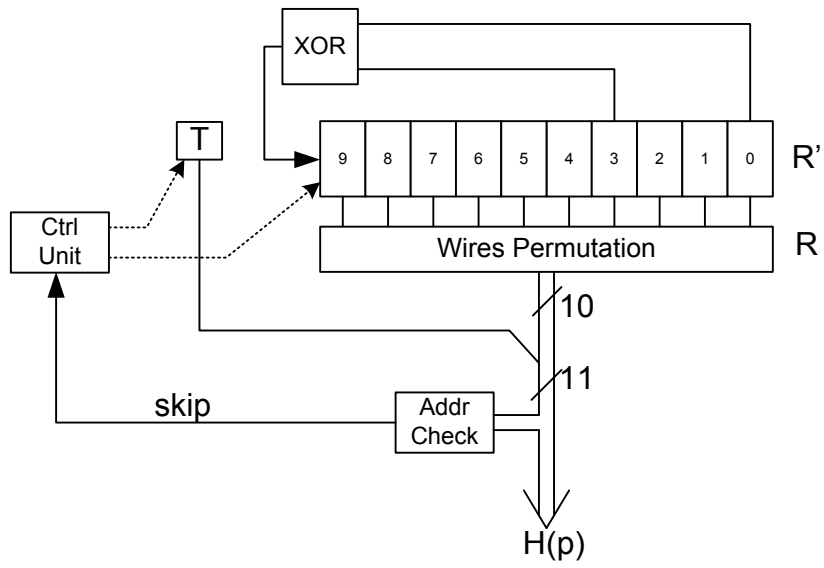


Figure 46(b): Frequency interleaver address generation scheme for the 2k mode

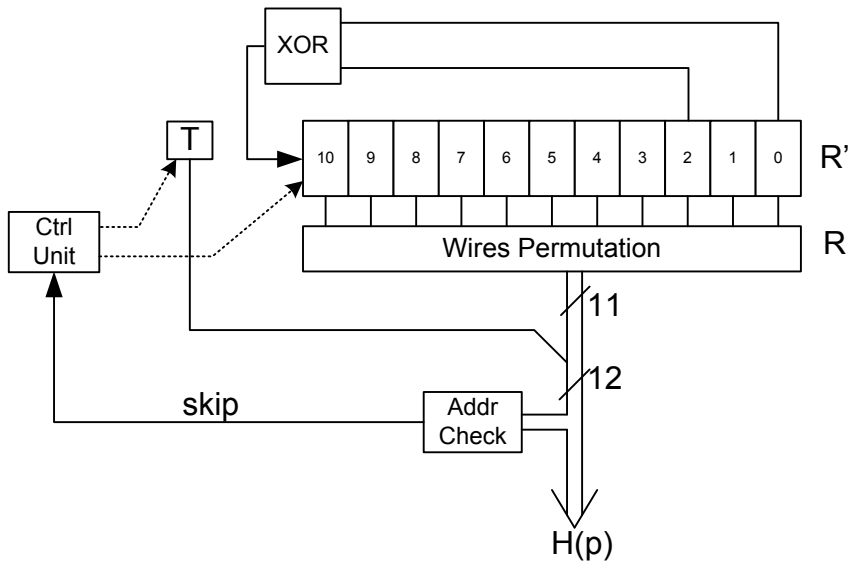


Figure 46(c): Frequency interleaver address generation scheme for the 4k mode

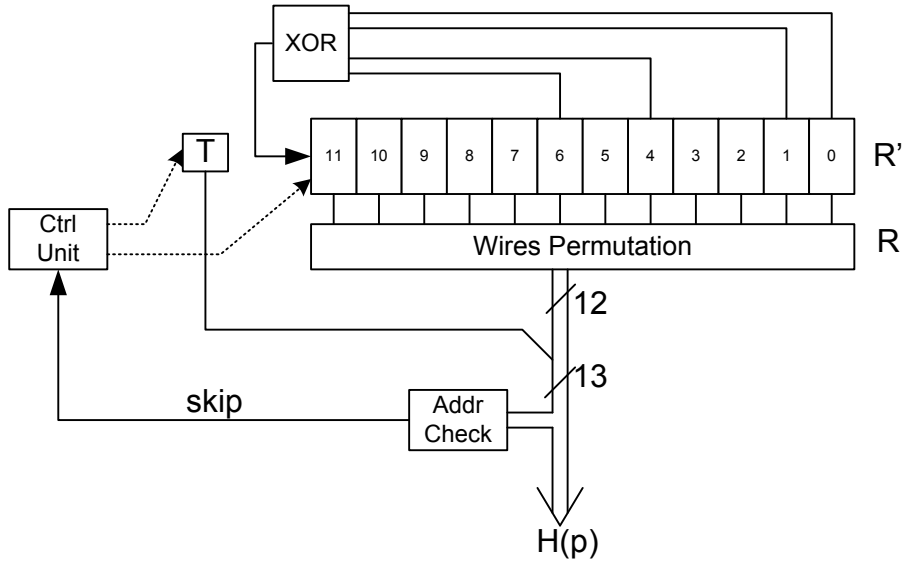


Figure 46(d): Frequency interleaver address generation scheme for the 8k mode

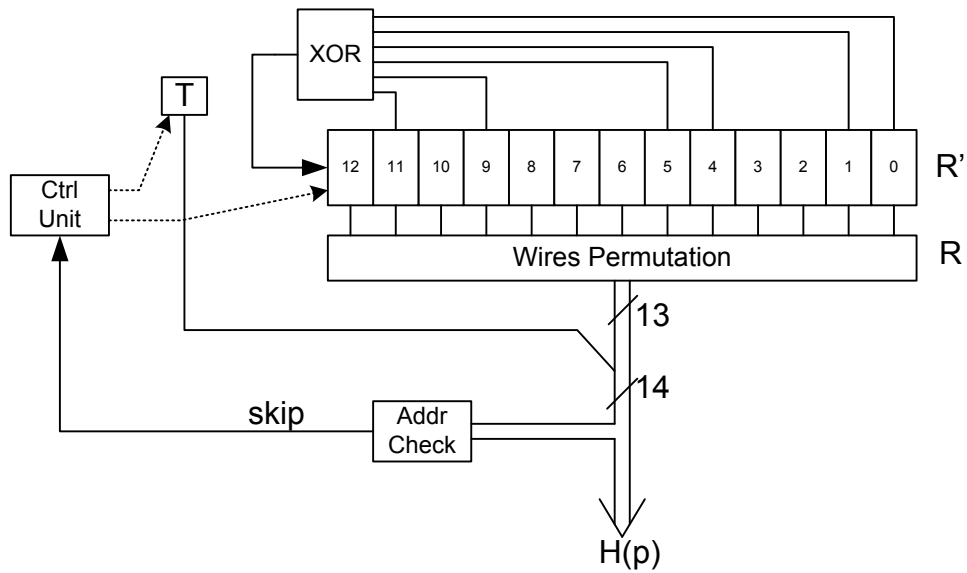
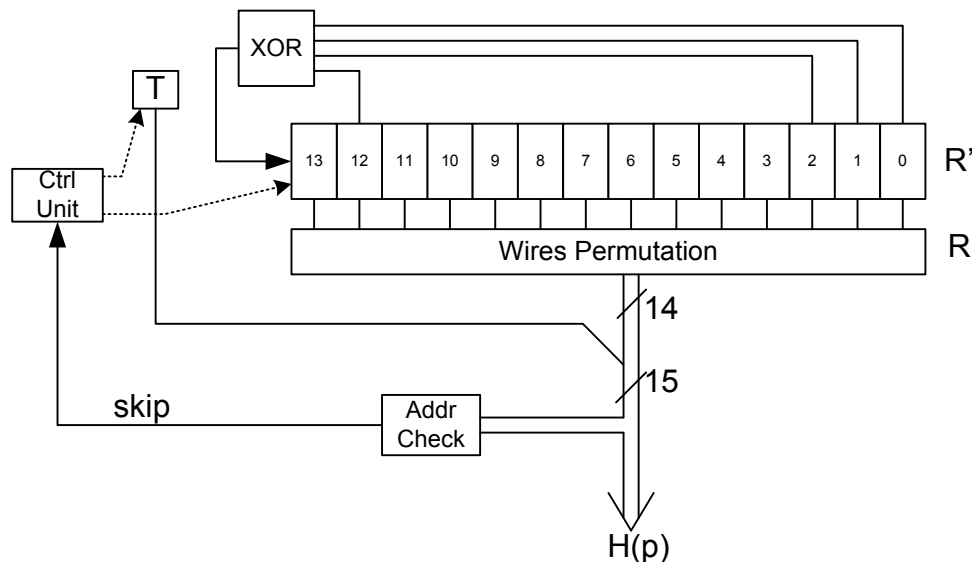


Figure 46(e): Frequency interleaver address generation scheme for the 16k mode





**Figure 46(f): Frequency interleaver address generation scheme for the 3k mode**

The output of the frequency interleaver is the interleaved vector of data cells  $A_{m,l} = (a_{m,l,0}, a_{m,l,1}, a_{m,l,2}, \dots, a_{m,l,N_{data}-1})$  for symbol  $l$  of T2-frame  $m$ .

## 9 OFDM Generation

The function of the OFDM generation module is to take the cells produced by the frame builder, as frequency domain coefficients, to insert the relevant reference information, known as pilots, which allow the receiver to compensate for the distortions introduced by the transmission channel, and to produce from this the basis for the time domain signal for transmission. It then inserts guard intervals and, if relevant, applies PAPR reduction processing to produce the completed T2 signal.

An optional initial stage, known as MISO processing, allows the initial frequency domain coefficients to be processed by a modified Alamouti encoding, which allows the T2 signal to be split between two groups of transmitters on the same frequency in such a way that the two groups will not interfere with each other.

### 9.1 MISO Processing

All symbols of the DVB-T2 signal, except as described in clause 8.3.7, may have MISO processing applied on cell level. It is assumed that all DVB-T2 receivers shall be able to receive signals with MISO processing applied. MISO processing consists of taking the input data cells and producing two similar sets of data cells at the output, each of which will be directed to the two groups of transmitters. A modified Alamouti encoding is used to produce the two sets of data cells, except that the encoding is never applied to the preamble symbol P1 and the pilots are processed as described in clause 9.2.8.

The encoding process is done on pairs of OFDM payload cells  $(a_{m,l,p}, a_{m,l,p+1})$  from the output of the frequency interleaver. The encoded OFDM payload cells  $e_{m,l,p}(Tx1)$  for MISO transmitter group 1 and  $e_{m,l,p}(Tx2)$  for MISO transmitter group 2 shall be generated from the input cells according to:

$$\begin{aligned} e_{m,l,p}(Tx1) &= a_{m,l,p} & e_{m,l,p+1}(Tx1) &= a_{m,l,p+1} & p \in \{0,2,4,6,\dots,N_{data}-2\} \\ e_{m,l,p}(Tx2) &= -a_{m,l,p+1}^* & e_{m,l,p+1}(Tx2) &= a_{m,l,p}^* & p \in \{0,2,4,6,\dots,N_{data}-2\} \end{aligned}$$

where  $*$  denotes the complex conjugation operation and  $N_{data}$  is the number of cells at the frequency interleaver output for the current symbol  $l$ , as defined in clause 8.5. The scheme is illustrated in figure 47.

NOTE 1: The MISO processing for transmitters in MISO group 1 copies the input cells unmodified to the output.

NOTE 2:  $N_{\text{data}}$  will always be an even number, even in the frame closing symbol, even though the values  $C_{\text{FC}}$  might not be even.

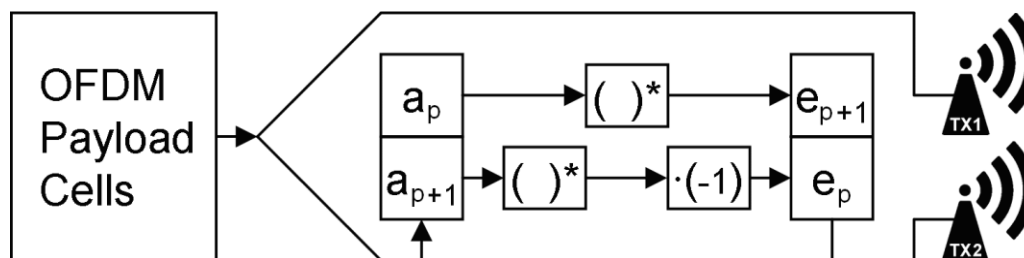


Figure 47: Multiple Input, Single Output, Encoder processing of OFDM payload cells

The encoding process is repeated for each pair of payload cells in turn. MISO processing shall not be applied to the P1 symbol. The contents of the P1 symbol will be identical between the two groups of transmitters.

If MISO is not used, the input cells shall be copied directly to the output, i.e.  $e_{m,l,p} = a_{m,l,p}$  for  $p=0,1,2,\dots,N_{\text{data}}-1$ .

## 9.2 Pilot insertion

### 9.2.1 Introduction

Various cells within the OFDM frame are modulated with reference information whose transmitted value is known to the receiver. Cells containing reference information are transmitted at "boosted" power level. The information transmitted in these cells are scattered, continual, edge, P2 or frame-closing pilot cells. The locations and amplitudes of these pilots are defined in clauses 9.2.3 to 9.2.7 for SISO transmissions, and are modified according to clause 9.2.8 for MISO transmissions. The value of the pilot information is derived from a reference sequence, which is a series of values, one for each transmitted carrier on any given symbol (see clause 9.2.2).

The pilots can be used for frame synchronization, frequency synchronization, time synchronization, channel estimation, transmission mode identification and can also be used to follow the phase noise.

Table 54 gives an overview of the different types of pilot and the symbols in which they appear.

Table 54: Presence of the various types of pilots in each type of symbol (X=present)

Symbol	PILOT TYPE				
	Scattered	Continual	Edge	P2	FRAME-CLOSING
P1					
P2				X	
Normal	X	X	X		
Frame closing			X		X

The following clauses specify values for  $c_{m,l,k}$  for certain values of  $m$ ,  $l$  and  $k$ , where  $m$  and  $l$  are the T2-frame and symbol number as previously defined, and  $k$  is the OFDM carrier index (see clause 9.5).

### 9.2.2 Definition of the reference sequence

The pilots are modulated according to a reference sequence,  $r_{l,k}$ , where  $l$  and  $k$  are the symbol and carrier indices as previously defined. The reference sequence is derived from a symbol level PRBS,  $w_k$  (see clause 9.2.2.1) and a frame level PN-sequence,  $pn_l$  (see clause 9.2.2.2). This reference sequence is applied to all the pilots (i.e. Scattered, Continual Edge, P2 and Frame Closing pilots) of each symbol of a T2-frame, including both P2 and Frame Closing symbols (see clause 8.3).

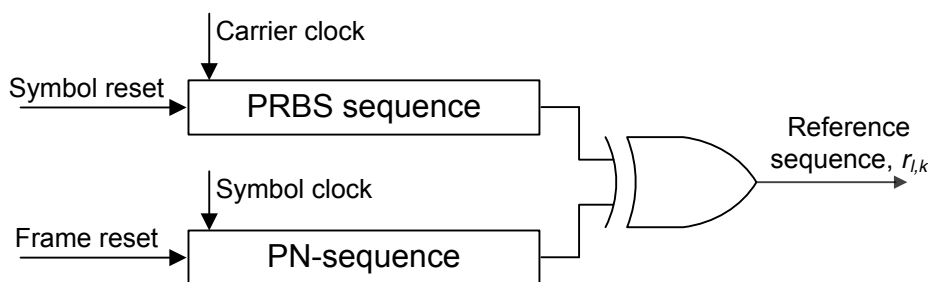
The output of the symbol level sequence,  $w_k$ , is inverted or not inverted according to the frame level sequence,  $pn_l$ , as shown in figure 48.

The symbol-level PRBS is mapped to the carriers such that the first output bit ( $w_0$ ) from the PRBS coincides with the first active carrier ( $k=K_{\min}$ ) in 1K, 2K and 4K. In 8K, 16K and 32K bit  $w_0$  coincides with the first active carrier ( $k=K_{\min}$ ) in the extended carrier mode. In the normal carrier mode, carrier  $k=K_{\min}$  is modulated by the output bit of the sequence whose index is  $K_{\text{ext}}$  (see table 66 for values of  $K_{\text{ext}}$ ). This ensures that the same modulation is applied to the same physical carrier in both normal and extended carrier modes.

A new value is generated by the PRBS on every used carrier (whether or not it is a pilot).

Hence:

$$r_{l,k} = \begin{cases} w_{k+K_{\text{ext}}} \oplus pn_l & \text{normal carrier mode} \\ w_k \oplus pn_l & \text{extended carrier mode} \end{cases}$$

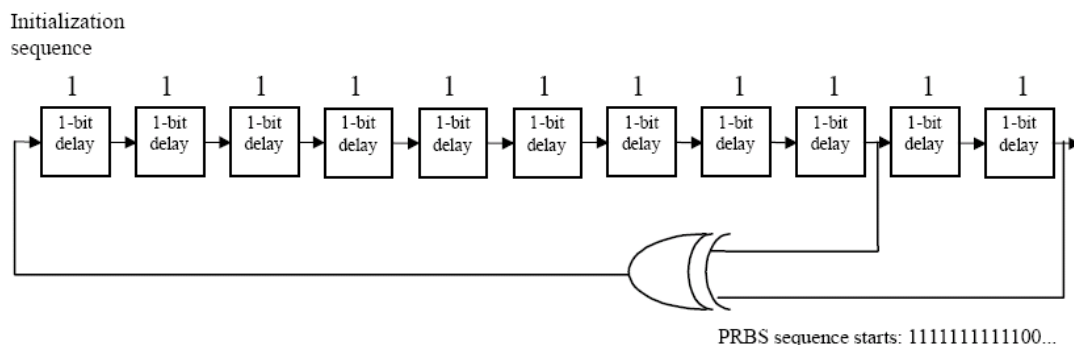


**Figure 48: Formation of the reference sequence from the PN and PRBS sequences**

### 9.2.2.1 Symbol level

The symbol level PRBS sequence,  $w_i$  is generated according to figure 49.

The shift register is initialized with all '1's so that the sequence begins  $w_0, w_1, w_2 \dots = 1, 1, 1, 1, 1, 1, 1, 1, 1, 1, 0, 0 \dots$



**Figure 49: Generation of PRBS sequence**

The polynomial for the PRBS generator shall be:

$$X^{11} + X^2 + 1 \text{ (see figure 49)}$$

NOTE: This sequence is used regardless of the FFT size and provides a unique signature in the time domain for each FFT size and also for each pilot pattern configuration.

### 9.2.2.2 Frame level

Each value of the frame level PN-sequence is applied to one OFDM symbol of the T2-frame. The length of the frame level PN-sequence  $N_{\text{PN}}$  is therefore equal to the T2-frame length  $L_{\text{F}}$  (see clause 8.3.1) i.e. the number of symbols in the T2-frame excluding P1. Table 55 shows the maximum length of PN-sequence for different FFT modes in 8 MHz

channels. The maximum number of symbols per frame will be different for channel bandwidths other than 8 MHz (see table 65). The greatest possible value of  $N_{PN}$  is 2 624 (for 10 MHz bandwidth).

**Table 55: Maximum lengths of PN-sequences for different FFT modes (8 MHz channel)**

FFT mode	Maximum sequence length, $N_{PN}$ (chips)
1K	2 098
2K	1 081
4K	540
8K	276
16K	138
32K	69

The sequence  $(pn_0, pn_1, \dots, pn_{N_{PN}-1})$  of length  $N_{PN} = L_F$ , shall be formed by taking the first  $N_{PN}$  bits from an overall PN-sequence. The overall PN-sequence is defined by table 56, and each four binary digits of the overall sequence are formed from the hexadecimal digits in table 56 taking the MSB first.

NOTE: The overall PN-sequence has been optimized by fragment by using as starting point the fully optimized short PN-sequence of length 15. Each relevant length of a given PN-sequence derives from this latter sequence. This unique sequence can be used to achieve frame synchronization efficiently.

**Table 56: PN-sequence Frame level (up to 2 624 chips) Hexadecimal description**

```
4DC2AF7BD8C3C9A1E76C9A090AF1C3114F07FCA2808E9462E9AD7B712D6F4AC8A59BB069CC50BF1149927E6B
B1C9FC8C18BB949B30CD09DDD749E704F57B41DEC7E7B176E12C5657432B51B0B812DF0E14887E24D80C97F09
374AD76270E58FE1774B2781D8D3821E393F2EA0FFD4D24DE20C05D0BA1703D10E52D61E013D837AA62D007CC
2FD76D23A3E125BDE8A9A7C02A98B70251C556F6341EBDECB801AAD5D9FB8CBEA80BB619096527A8C475B3D8
DB28AF8543A00EC3480DFF1E2CDA9F985B523B879007AA5D0CE58D21B18631006617F6F769EB947F924EA5161E
C2C0488B63ED7993BA8EF4E552FA32FC3F1BDB19923902BCBBE5DDABB824126E08459CA6CFA0267E5294A98C6
32569791E60EF659AEE9518CDF08D87833690C1B79183ED127E53360CD86514859A28B5494F51AA4882419A25A2
D01A5F47AA27301E79A5370CCB3E197F
```

## 9.2.3 Scattered pilot insertion

Reference information, taken from the reference sequence, is transmitted in scattered pilot cells in every symbol except P1, P2 and the frame-closing symbol (if applicable) of the T2-frame. The locations of the scattered pilots are defined in clause 9.2.3.1, their amplitudes are defined in clause 9.2.3.2 and their modulation is defined in clause 9.2.3.3.

### 9.2.3.1 Locations of the scattered pilots

A given carrier  $k$  of the OFDM signal on a given symbol  $l$  will be a scattered pilot if the appropriate equation below is satisfied:

$$\begin{aligned} k \bmod (D_X \cdot D_Y) &= D_X (l \bmod D_Y) && \text{normal carrier mode} \\ (k - K_{ext}) \bmod (D_X \cdot D_Y) &= D_X (l \bmod D_Y) && \text{extended carrier mode} \end{aligned}$$

where:  $D_X, D_Y$  are defined in table 57:

$k \in [K_{min}; K_{max}]$ ; and

$l \in [N_{p2}; L_F - 2]$  when there is a frame closing symbol; and

$l \in [N_{p2}; L_F - 1]$  when there is no frame closing symbol.

$N_{p2}$  and  $L_F$  are as defined in clause 8.3.1 and  $K_{ext}$  is defined in table 66.

**Table 57: Parameters defining the scattered pilot patterns**

Pilot pattern	Separation of pilot bearing carriers ( $D_x$ )	Number of symbols forming one scattered pilot sequence ( $D_y$ )
PP1	3	4
PP2	6	2
PP3	6	4
PP4	12	2
PP5	12	4
PP6	24	2
PP7	24	4
PP8	6	16

NOTE 1: Pilot pattern PP8 is not used for T2-Lite – see annex I.

The combinations of scattered pilot patterns, FFT size and guard interval which are allowed to be used are defined in table 58 for SISO mode and in table 59 for MISO mode.

NOTE 2: The modifications of the pilots for MISO mode are described in clause 9.2.8.

**Table 58: Scattered pilot pattern to be used for each allowed combination of FFT size and guard interval in SISO mode**

FFT size	Guard interval						
	1/128	1/32	1/16	19/256	1/8	19/128	1/4
32K	PP7	PP4 PP6	PP2 PP8 PP4	PP2 PP8 PP4	PP2 PP8	PP2 PP8	NA
16K	PP7	PP7 PP4 PP6	PP2 PP8 PP4 PP5	PP2 PP8 PP4 PP5	PP2 PP3 PP8	PP2 PP3 PP8	PP1 PP8
8K	PP7	PP7 PP4	PP8 PP4 PP5	PP8 PP4 PP5	PP2 PP3 PP8	PP2 PP3 PP8	PP1 PP8
4K, 2K	NA	PP7 PP4	PP4 PP5	NA	PP2 PP3	NA	PP1
1K	NA	NA	PP4 PP5	NA	PP2 PP3	NA	PP1

**Table 59: Scattered pilot pattern to be used for each allowed combination of FFT size and guard interval in MISO mode**

FFT size	Guard interval						
	1/128	1/32	1/16	19/256	1/8	19/128	1/4
32K	PP8 PP4 PP6	PP8 PP4	PP2 PP8	PP2 PP8	NA	NA	NA
16K	PP8 PP4 PP5	PP8 PP4 PP5	PP3 PP8	PP3 PP8	PP1 PP8	PP1 PP8	NA
8K	PP8 PP4 PP5	PP8 PP4 PP5	PP3 PP8	PP3 PP8	PP1 PP8	PP1 PP8	NA
4K, 2K	NA	PP4 PP5	PP3	NA	PP1	NA	NA
1K	NA	NA	PP3	NA	PP1	NA	NA

NOTE 2: For the 32K case (SISO or MISO), it is not expected that a receiver will need to implement linear temporal interpolation of the pilots over more than 2 OFDM symbols. For all other cases, a maximum of four symbols of linear temporal interpolation are assumed. For the pilot pattern PP8, it is assumed that a receiver will use a "zero-order-hold" technique, although other more advanced techniques may be used if desired.

NOTE 3: When the value  $D_X D_Y$  (with  $D_X$  and  $D_Y$  taken from table 57) is less than the reciprocal of the guard interval fraction, it is assumed that frequency only interpolation will be used in SISO mode, and hence the frame closing symbol is also not required.

NOTE 4: The allowed combinations of scattered pilot pattern, FFT size and guard interval are modified for T2-Lite – see annex I.

The scattered pilot patterns are illustrated in annex K.

### 9.2.3.2 Amplitudes of the scattered pilots

The amplitudes of the scattered pilots,  $A_{SP}$ , depend on the scattered pilot pattern as shown in table 60.

**Table 60: Amplitudes of the scattered pilots**

Scattered pilot pattern	Amplitude ( $A_{SP}$ )	Equivalent Boost (dB)
PP1, PP2	4/3	2,5
PP3, PP4	7/4	4,9
PP5, PP6, PP7, PP8	7/3	7,4

### 9.2.3.3 Modulation of the scattered pilots

The phases of the scattered pilots are derived from the reference sequence given in clause 9.2.2.

The modulation value of the scattered pilots is given by:

$$\text{Re}\{c_{m,l,k}\} = 2 A_{SP} (1/2 - r_{l,k})$$

$$\text{Im}\{c_{m,l,k}\} = 0$$

where  $A_{SP}$  is as defined in clause 9.2.3.2,  $r_{l,k}$  is defined in clause 9.2.2,  $m$  is the T2-frame index,  $k$  is the frequency index of the carriers and  $l$  is the time index of the symbols.

## 9.2.4 Continual pilot insertion

In addition to the scattered pilots described above, a number of continual pilots are inserted in every symbol of the frame except for P1 and P2 and the frame closing symbol (if any). The number and location of continual pilots depends on both the FFT size and scattered pilot pattern PP1-PP8 in use (see clause 9.2.3).

### 9.2.4.1 Locations of the continual pilots

The continual pilot locations are taken from one or more "CP groups" depending on the FFT mode. Table 61 indicates which CP groups are used in each FFT mode. The pilot locations belonging to each CP group depend on the scattered pilot pattern in use; table G.1 gives the carrier indices  $k_{i,32K}$  for each pilot pattern in the 32K mode. In other FFT modes, the carrier index for each CP is given by  $k = k_{i,32K} \bmod K_{\text{mod}}$ , where  $K_{\text{mod}}$  for each FFT size is given in table 61.

**Table 61: Continual Pilot groups used with each FFT size**

FFT size	CP Groups used	$K_{\text{mod}}$
1K	CP <sub>1</sub>	1 632
2K	CP <sub>1</sub> , CP <sub>2</sub>	1 632
4K	CP <sub>1</sub> , CP <sub>2</sub> , CP <sub>3</sub>	3 264
8K	CP <sub>1</sub> , CP <sub>2</sub> , CP <sub>3</sub> , CP <sub>4</sub>	6 528
16K	CP <sub>1</sub> , CP <sub>2</sub> , CP <sub>3</sub> , CP <sub>4</sub> , CP <sub>5</sub>	13 056
32K	CP <sub>1</sub> , CP <sub>2</sub> , CP <sub>3</sub> , CP <sub>4</sub> , CP <sub>5</sub> , CP <sub>6</sub>	NA

### 9.2.4.2 Locations of additional continual pilots in extended carrier mode

In extended carrier mode, extra continual pilots are added to those defined in the previous clause. The carrier indices  $k$  for the additional continual pilots are given in table G.2 (see annex G) for each FFT size and scattered pilot pattern.

### 9.2.4.3 Amplitudes of the Continual Pilots

The continual pilots are transmitted at boosted power levels, where the boosting depends on the FFT size. Table 62 gives the modulation amplitude  $A_{CP}$  for each FFT size.

**Table 62: Boosting for the continual pilots**

FFT size	1K	2K	4K	8K	16K	32K
$A_{CP}$	4/3	4/3	$(4\sqrt{2})/3$	8/3	8/3	8/3

When a carrier's location is such that it would be both a continual and scattered pilot, the boosting value for the scattered pilot pattern shall be used ( $A_{SP}$ ).

### 9.2.4.4 Modulation of the Continual Pilots

The phases of the continual pilots are derived from the reference sequence given in clause 9.2.2.

The modulation value for the continual pilots is given by:

$$\text{Re}\{c_{m,l,k}\} = 2 A_{CP} (1/2 - r_{l,k})$$

$$\text{Im}\{c_{m,l,k}\} = 0.$$

where  $A_{CP}$  is as defined in clause 9.2.4.3.

## 9.2.5 Edge pilot insertion

The edge carriers, carriers  $k=K_{\text{min}}$  and  $k=K_{\text{max}}$ , are edge pilots in every symbol except for the P1 and P2 symbol(s).

They are inserted in order to allow frequency interpolation up to the edge of the spectrum. The modulation of these cells is exactly the same as for the scattered pilots, as defined in clause 9.2.3.3:

$$\text{Re}\{c_{m,l,k}\} = 2 A_{SP} (1/2 - r_{l,k})$$

$$\text{Im}\{c_{m,l,k}\} = 0.$$

## 9.2.6 P2 pilot insertion

### 9.2.6.1 Locations of the P2 pilots

In 32K SISO mode, cells in the P2 symbol(s) for which  $k \bmod 6 = 0$  are P2 pilots.

In all other modes (including 32K MISO), cells in the P2 symbol(s) for which  $k \bmod 3 = 0$  are P2 pilots.

In extended carrier mode, all cells for which  $K_{\min} \leq k < K_{\min} + K_{\text{ext}}$  and for which  $K_{\max} - K_{\text{ext}} < k \leq K_{\max}$  are also P2 pilots.

### 9.2.6.2 Amplitudes of the P2 pilots

The pilot cells in the P2 symbol(s) are transmitted at boosted power levels. Table 63 gives the modulation amplitude  $A_{P2}$  for the P2 pilots.

**Table 63: Amplitude of P2 pilots**

Mode	$A_{P2}$
32K SISO	$\frac{\sqrt{37}}{5}$
All other modes (including 32K MISO)	$\frac{\sqrt{31}}{5}$

### 9.2.6.3 Modulation of the P2 pilots

The phases of the P2 pilots are derived from the reference sequence given in clause 9.2.2.

The corresponding modulation is given by:

$$\text{Re}\{c_{m,l,k}\} = 2 A_{P2} (1/2 - r_{l,k})$$

$$\text{Im}\{c_{m,l,k}\} = 0$$

where  $m$  is the T2-frame index,  $k$  is the frequency index of the carriers and  $l$  is the symbol index.

## 9.2.7 Insertion of frame closing pilots

When any of the combinations of FFT size, guard interval and scattered pilot pattern listed in table 64 (for SISO mode) is used, the last symbol of the frame is a special frame closing symbol (see also clause 8.3.2). Frame closing symbols are always used in MISO mode, except with pilot pattern PP8, when frame closing symbols are never used.

**Table 64: Combinations of FFT size, guard interval and pilot pattern for which frame closing symbols are used in SISO mode**

FFT size	Guard interval						
	1/128	1/32	1/16	19/256	1/8	19/128	1/4
32K		PP6	PP4	PP4	PP2	PP2	NA
16K		PP7 PP6	PP4 PP5	PP4 PP5	PP2 PP3	PP2 PP3	PP1
8K		PP7	PP4 PP5	PP4 PP5	PP2 PP3	PP2 PP3	PP1
4K, 2K	NA	PP7	PP4 PP5	NA	PP2 PP3	NA	PP1
1K	NA	NA	PP4 PP5	NA	PP2 PP3	NA	PP1

NOTE: The entry 'NA' indicates that the corresponding combination of FFT size and guard interval is not allowed. An empty entry indicates that the combination of FFT size and guard interval is allowed, but frame closing symbols are never used.



### 9.2.7.1 Locations of the frame closing pilots

The cells in the frame closing symbol for which  $k \bmod D_X = 0$ , except when  $k = K_{\min}$  and  $k = K_{\max}$ , are frame closing pilots, where  $D_X$  is the value from table 57 for the scattered pilot pattern in use. With an FFT size of 1K with pilot patterns PP4 and PP5, and with an FFT size of 2K with pilot pattern PP7, carrier  $K_{\max}-1$  shall be an additional frame closing pilot.

NOTE: Cells in the frame closing symbol for which  $k = K_{\min}$  or  $k = K_{\max}$  are edge pilots, see clause 9.2.5.

### 9.2.7.2 Amplitudes of the frame closing pilots

The frame closing pilots are boosted by the same factor as the scattered pilots,  $A_{SP}$ .

### 9.2.7.3 Modulation of the frame closing pilots

The phases of the frame closing pilots are derived from the reference sequence given in clause 9.2.2.

The corresponding modulation is given by:

$$\operatorname{Re}\{c_{m,l,k}\} = 2 A_{SP} (1/2 - r_{l,k})$$

$$\operatorname{Im}\{c_{m,l,k}\} = 0$$

Where  $m$  is the T2-frame index,  $k$  is the frequency index of the carriers and  $l$  is the time index of the symbols.

## 9.2.8 Modification of the pilots for MISO

In MISO mode, the phases of the scattered, continual, edge and frame-closing pilots are modified in the signal transmitted from any transmitter from transmitters in MISO group 2.

The scattered pilots from transmitters in MISO group 2 are inverted compared to MISO group 1 on alternate scattered-pilot-bearing carriers:

$$\operatorname{Re}\{c_{m,l,k}\} = 2(-1)^{k/D_X} A_{SP} (1/2 - r_{l,k})$$

$$\operatorname{Im}\{c_{m,l,k}\} = 0.$$

The continual pilots from transmitters in MISO group 2 falling on scattered-pilot-bearing carriers are inverted compared to MISO group 1 on carriers for which the scattered pilots are inverted; continual pilots on non-scattered-pilot-bearing carriers are not inverted:

$$\operatorname{Re}\{c_{m,l,k}\} = \begin{cases} 2(-1)^{k/D_X} A_{CP} (1/2 - r_{l,k}) & k \bmod D_X = 0 \\ 2A_{CP} (1/2 - r_{l,k}) & \text{otherwise} \end{cases}$$

$$\operatorname{Im}\{c_{m,l,k}\} = 0.$$

NOTE: Those cells which would be both a continual and a scattered pilot are treated as scattered pilots as described above and therefore have the amplitude  $A_{SP}$ .

The edge pilots from transmitters in MISO group 2 are inverted compared to MISO group 1 on odd-numbered OFDM symbols:

$$\operatorname{Re}\{c_{m,l,k}\} = 2 (-1)^l A_{SP} (1/2 - r_{l,k})$$

$$\operatorname{Im}\{c_{m,l,k}\} = 0.$$

The P2 pilots from transmitters in MISO group 2 are inverted compared to MISO group 1 on carriers whose indices are odd multiples of three:

$$\operatorname{Re} \{ c_{m,l,k} \} = \begin{cases} 2(-1)^{k/3} A_{P2}(1/2 - r_{l,k}) & k \bmod 3 = 0 \\ 2A_{P2}(1/2 - r_{l,k}) & \text{otherwise} \end{cases}$$

$$\operatorname{Im} \{ c_{m,l,k} \} = 0.$$

The frame closing pilots from transmitters in group 2 are inverted compared to group 1 on alternate scattered-pilot-bearing carriers:

$$\operatorname{Re} \{ c_{m,l,k} \} = 2(-1)^{k/D_X} A_{SP}(1/2 - r_{l,k})$$

$$\operatorname{Im} \{ c_{m,l,k} \} = 0.$$

The locations and amplitudes of the pilots in MISO are the same as in SISO mode for transmitters from both MISO group 1 and MISO group 2, but additional P2 pilots are also added.

In normal carrier MISO mode, carriers in the P2 symbol(s) for which  $k = K_{\min} + 1$ ,  $k = K_{\min} + 2$ ,  $k = K_{\max} - 2$  and  $k = K_{\max} - 1$  are additional P2 pilots, but are the same for transmitters from both MISO group 1 and MISO group 2.

In extended carrier MISO mode, carriers in the P2 symbol(s) for which  $k = K_{\min} + K_{\text{ext}} + 1$ ,  $k = K_{\min} + K_{\text{ext}} + 2$ ,  $k = K_{\max} - K_{\text{ext}} - 2$  and  $k = K_{\max} - K_{\text{ext}} - 1$  are additional P2 pilots, but are the same for transmitters from both MISO group 1 and MISO group 2.

Hence for these additional P2 pilots in MISO mode:

$$\operatorname{Re} \{ c_{m,l,k} \} = 2 A_{P2} (1/2 - r_{l,k})$$

$$\operatorname{Im} \{ c_{m,l,k} \} = 0.$$

Further additional P2 pilots are also added in MISO mode in the cells adjacent to the Tone Reservation cells which are not already defined to be P2 pilots except when these adjacent cells are also defined as Tone Reservation cells.

The carrier indices  $k$  are therefore given:

$$k = \begin{cases} k_i + 1 & k_i \bmod 3 = 1, k_i \in S_{P2}, k_i + 1 \notin S_{P2} \\ k_i - 1 & k_i \bmod 3 = 2, k_i \in S_{P2}, k_i - 1 \notin S_{P2} \end{cases}$$

and  $S_{P2}$  is the set of reserved tones in the P2 symbol given in table H.1.

## 9.3 Dummy tone reservation

Some OFDM cells can be reserved for the purpose of PAPR reduction and they shall be initially set to  $c_{m,l,k} = 0 + 0j$ .

In P2 symbol(s), the set of carriers corresponding to carrier indices defined in table H.1 shall be always reserved in normal carrier mode. In extended carrier mode, the reserved carrier indices shall be equal to the values from the table plus  $K_{\text{ext}}$ . The reserved carrier indices shall not change across the P2 symbol(s), i.e. keep the same positions across the P2 symbol(s).

In the data symbols excluding any frame closing symbol, the set of carriers corresponding to carrier indices defined in table H.2 (see annex H) or their circularly shifted set of carriers shall be reserved depending on OFDM symbol index of the data symbol, when TR is activated by a relevant L1-pre signalling field, 'PAPR'. The amount of shift between two consecutive OFDM symbols shall be determined by the separation of pilot bearing carriers,  $D_X$  and the number of symbols forming one scattered pilot sequence,  $D_Y$  (see table 57 in clause 9.2.3.1). In the data symbol corresponding to data symbol index  $l$  of a T2-frame, the reserved carrier set,  $S_l$  shall be determined as:

$$S_l = \begin{cases} i_k + D_X * (l \bmod D_Y) & \text{normal carrier mode} \\ i_k + D_X * \left( \left( l + \frac{K_{\text{ext}}}{D_X} \right) \bmod D_Y \right) & \text{extended carrier mode} \end{cases} \left| \begin{array}{l} i_n \in S_0, 0 \leq n < N_{RT}, N_{P2} \leq l < N_{P2} + L_{\text{normal}} \end{array} \right.$$

where  $S_0$  represents the set of reserved carriers corresponding to carrier indices defined in table H.2 and  $L_{\text{normal}}$  denotes the number of normal symbols in a T2-frame, i.e. not including P1, P2 or any frame closing symbol.

When the frame closing symbol is used (see clause 9.2.7), the set of carriers in the frame closing symbol corresponding to the same carrier indices as for the P2 symbol(s), defined in table H.1, shall be reserved when TR is activated.

## 9.4 Mapping of data cells to OFDM carriers

Any cell  $c_{m,l,k}$  in the P2 or data symbols which has not been designated as a pilot (see clause 9.2) or as a reserved tone (see clause 9.3) shall carry one of the data cells from the MISO processor, i.e.  $c_{m,l,k} = e_{m,l,p}$ . The cells  $e_{m,l,p}$  for symbol  $l$  in T2-frame  $m$  shall be taken in increasing order of the index  $p$ , and assigned to  $c_{m,l,k}$  of the symbol in increasing order of the carrier index  $k$  for the values of  $k$  in the range  $K_{\min} \leq k \leq K_{\max}$  designated as data cells by the definition above.

## 9.5 IFFT - OFDM Modulation

This clause specifies the OFDM structure to use for each transmission mode. The transmitted signal is organized in frames. Each frame has a duration of  $T_F$ , and consists of  $L_F$  OFDM symbols.  $N_{T2}$  frames constitute one super-frame. Each symbol is constituted by a set of  $K_{\text{total}}$  carriers transmitted with a duration  $T_S$ . It is composed of two parts: a useful part with duration  $T_U$  and a guard interval with a duration  $\Delta$ . The guard interval consists of a cyclic continuation of the useful part,  $T_U$ , and is inserted before it. The allowed combinations of FFT size and guard interval are defined in table 67.

The symbols in an OFDM frame (excluding P1) are numbered from 0 to  $L_F-1$ . All symbols contain data and reference information.

Since the OFDM signal comprises many separately-modulated carriers, each symbol can in turn be considered to be divided into cells, each corresponding to the modulation carried on one carrier during one symbol.

The carriers are indexed by  $k \in [K_{\min}; K_{\max}]$  and determined by  $K_{\min}$  and  $K_{\max}$ . The spacing between adjacent carriers is  $1/T_U$  while the spacing between carriers  $K_{\min}$  and  $K_{\max}$  are determined by  $(K_{\text{total}}-1)/T_U$ .

The emitted signal, when neither FEFs nor PAPR reduction are used, is described by the following expression:

$$s(t) = \text{Re} \left\{ e^{j2\pi f_c t} \sum_{m=0}^{\infty} \left[ p_1 \left( -mT_F \right) \frac{5}{\sqrt{27 \times K_{\text{total}}}} \sum_{l=0}^{L_F-1} \sum_{k=K_{\min}}^{K_{\max}} c_{m,l,k} \times \psi_{m,l,k}(t) \right] \right\}$$

where:

$$\psi_{m,l,k}(t) = \begin{cases} e^{j2\pi \frac{k}{T_U} (t - \Delta - T_{P1} - lT_S - mT_F)} & mT_F + T_{P1} + lT_S \leq t \leq mT_F + T_{P1} + (l+1)T_S \\ 0 & \text{otherwise} \end{cases}$$

and:

$k$  denotes the carrier number;

$l$  denotes the OFDM symbol number starting from 0 for the first P2 symbol of the frame;

$m$  denotes the T2-frame number;

$K_{\text{total}}$  is the number of transmitted carriers defined in table 66;

$L_F$  number of OFDM symbols per frame;

$T_S$  is the total symbol duration for all symbols except P1, and  $T_S = T_U + \Delta$ ;

- $T_U$  is the active symbol duration defined in table 66;
- $\Delta$  is the duration of the guard interval, see clause 9.7;
- $f_c$  is the central frequency of the RF signal;
- $k'$  is the carrier index relative to the centre frequency,  $k' = k - (K_{\max} + K_{\min}) / 2$ ;
- $c_{m,l,k}$  is the complex modulation value for carrier  $k$  of the OFDM symbol number  $l$  in T2-frame number  $m$ ;
- $T_{P1}$  is the duration of the P1 symbol, given by  $T_{P1}=2048T$ , and  $T$  is defined below;
- $T_F$  is the duration of a frame,  $T_F = L_F T_s + T_{P1}$ ;
- $p_1(t)$  is the P1 waveform as defined in clause 9.8.2.4.

NOTE 1: The power of the P1 symbol is defined to be essentially the same as the rest of the frame, but since the rest of the frame is normalized based on the number of transmitted carriers, the relative amplitudes of carriers in the P1 compared to the carriers of the normal symbols will vary depending whether or not extended carrier mode is used.

NOTE 2: The normalization factor  $5/\sqrt{27}$  in the above equation approximately corrects for the average increase in power caused by the boosting of the pilots, and so ensures the power of the P1 symbol is virtually the same as the power of the remaining symbols.

The OFDM parameters are summarized in table 66. The values for the various time-related parameters are given in multiples of the elementary period  $T$  and in microseconds. The elementary period  $T$  is specified for each bandwidth in table 65. For 8K, 16K and 32K FFT, an extended carrier mode is also defined.

**Table 65: Elementary period as a function of bandwidth**

Bandwidth	1,7 MHz	5 MHz	6 MHz	7 MHz	8 MHz	10 MHz (see note)
Elementary period $T$	71/131 $\mu$ s	7/40 $\mu$ s	7/48 $\mu$ s	1/8 $\mu$ s	7/64 $\mu$ s	7/80 $\mu$ s
NOTE:	This configuration is only intended for professional applications and is not expected to be supported by domestic receivers.					

Table 66: OFDM parameters

Parameter		1K mode	2K mode	4K mode	8K mode	16K mode	32K mode
Number of carriers $K_{\text{total}}$	normal carrier mode	853	1 705	3 409	6 817	13 633	27 265
	extended carrier mode	NA	NA	NA	6 913	13 921	27 841
Value of carrier number $K_{\text{min}}$	normal carrier mode	0	0	0	0	0	0
	extended carrier mode	NA	NA	NA	0	0	0
Value of carrier number $K_{\text{max}}$	normal carrier mode	852	1 704	3 408	6 816	13 632	27 264
	extended carrier mode	NA	NA	NA	6 912	13 920	27 840
Number of carriers added on each side in extended carrier mode $K_{\text{ext}}$ (see note 2)		0	0	0	48	144	288
Duration $T_U$		1 024 <i>T</i>	2 048 <i>T</i>	4 096 <i>T</i>	8 192 <i>T</i>	16 384 <i>T</i>	32 768 <i>T</i>
Duration $T_U$ $\mu\text{s}$ (see note 3)		112	224	448	896	1 792	3 584
Carrier spacing $1/T_U$ (Hz) (see notes 1 and 2)		8 929	4 464	2 232	1 116	558	279
Spacing between carriers $K_{\text{min}}$ and $K_{\text{max}}$ $(K_{\text{total}}-1)/T_U$ (see note 3)	normal carrier mode	7,61 MHz	7,61 MHz	7,61 MHz	7,61 MHz	7,61 MHz	7,61 MHz
	extended carrier mode	NA	NA	NA	7,71 MHz	7,77 MHz	7,77 MHz

NOTE 1: Numerical values in italics are approximate values.  
NOTE 2: This value is used in the definition of the pilot sequence in both normal and extended carrier mode.  
NOTE 3: Values for 8 MHz channels.

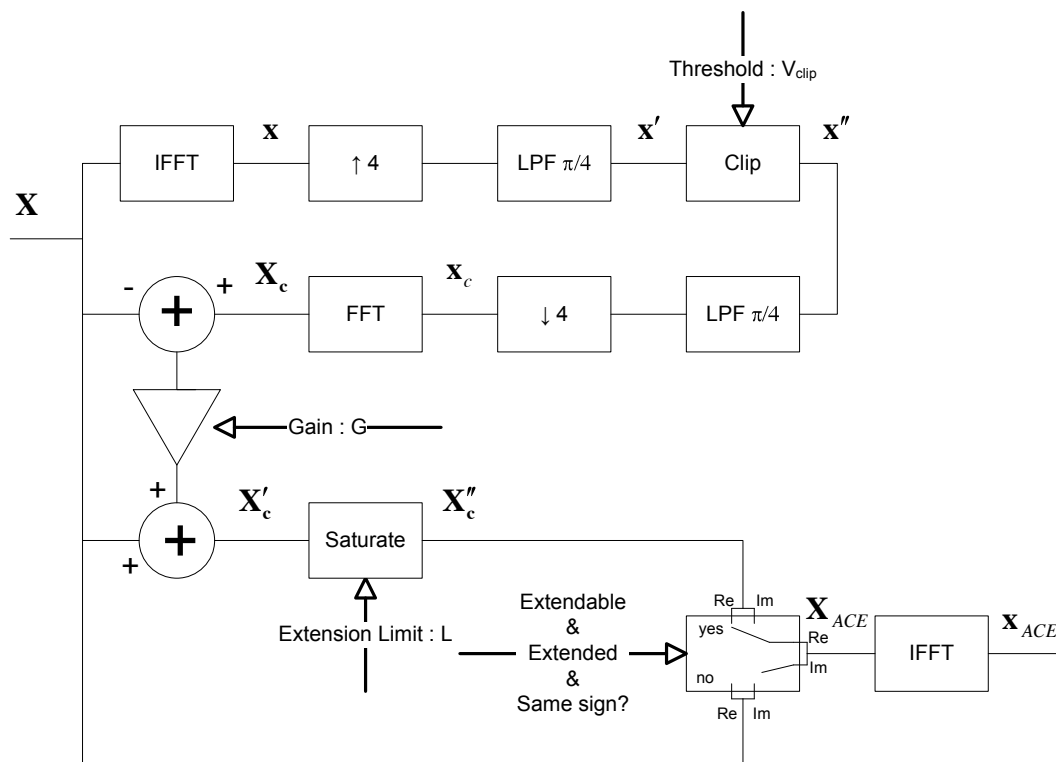
## 9.6 PAPR Reduction

Two modifications of the transmitted OFDM signal are allowed in order to decrease PAPR. One or both techniques may be used simultaneously. The use (or lack thereof) of the techniques shall be indicated in L1 signalling (see clause 7.2). The Active Constellation Extension technique is described in clause 9.6.1 and the Tone Reservation Technique is described in clause 9.6.2. Both techniques, when used, are applied to the active portion of each OFDM symbol (except P1), and following this, guard intervals shall be inserted (see clause 9.7). The active constellation extension technique shall not be applied to pilot carriers or reserved tones, nor when rotated constellations are used (see clause 6.3), nor when MISO is used (see clause 9.1). When both techniques are used, the Active Constellation Extension technique shall be applied to the signal first.

### 9.6.1 Active Constellation Extension

The Active Constellation Extension algorithm produces a time domain signal  $\mathbf{x}_{ACE}$  that replaces the original time domain signal  $\mathbf{x} = [x_0, x_1, \dots, x_{N_{FFT}-1}]$  produced by the IFFT from a set of frequency domain values

$$\mathbf{X} = [X_0, X_1, \dots, X_{N_{FFT}-1}]$$



**Figure 50: Implementation of the Active Constellation Extension algorithm**

$\mathbf{x}' = [x'_0, x'_1, \dots, x'_{4 \cdot N_{FFT} - 1}]$  is obtained from  $\mathbf{x}$  through interpolation by a factor of 4.

The combination of IFFT, oversampling and lowpass filtering is implemented using zero padding and a four times oversized IFFT operator.

$\mathbf{x}'' = [x''_0, x''_1, \dots, x''_{4 \cdot N_{FFT} - 1}]$  is obtained by applying a clipping operator to  $\mathbf{x}'$ .

The clipping operator is defined as follows:

$$x''_k = \begin{cases} x'_k & \text{if } \|x'_k\| \leq V_{clip} \\ V_{clip} \cdot \frac{x'_k}{\|x'_k\|} & \text{if } \|x'_k\| \geq V_{clip} \end{cases}$$

The clipping threshold  $V_{clip}$  is a parameter of the ACE algorithm.

$\mathbf{x}_c = [x_{c0}, x_{c1}, \dots, x_{cN_{FFT} - 1}]$  is obtained from  $\mathbf{x}''$  through decimation by a factor of 4.

The combination of lowpass filtering, downsampling and FFT is implemented using a four times oversized FFT operator.

$\mathbf{X}_c$  is obtained from  $\mathbf{x}_c$  through FFT.

A new signal  $\mathbf{X}'_c$  is obtained by combining  $\mathbf{X}_c$  and  $\mathbf{X}$  as follows:

$$\mathbf{X}'_c = \mathbf{X} + G \cdot (\mathbf{X}_c - \mathbf{X})$$

The extension gain  $G$  is a parameter of the ACE algorithm.

$\mathbf{X}_c''$  is obtained from  $\mathbf{X}_c'$  using a saturation operator which operates separately with real and imaginary components, ensuring that individual component magnitude cannot exceed a given value  $L$ .

$$\operatorname{Re} \mathbf{X}_{c,k}'' \begin{cases} \operatorname{Re} \mathbf{X}_{c,k}' & \text{if } |\operatorname{Re} \mathbf{X}_{c,k}'| \leq L \\ L & \text{if } \operatorname{Re} \mathbf{X}_{c,k}' > L \\ -L & \text{if } \operatorname{Re} \mathbf{X}_{c,k}' < -L \end{cases}$$

$$\operatorname{Im} \mathbf{X}_{c,k}'' \begin{cases} \operatorname{Im} \mathbf{X}_{c,k}' & \text{if } |\operatorname{Im} \mathbf{X}_{c,k}'| \leq L \\ L & \text{if } \operatorname{Im} \mathbf{X}_{c,k}' > L \\ -L & \text{if } \operatorname{Im} \mathbf{X}_{c,k}' < -L \end{cases}$$

The extension limit  $L$  is a parameter of the ACE algorithm.

$\mathbf{X}_{ACE}$  is then constructed by simple selection real and imaginary components from those of  $\mathbf{X}$ ,  $\mathbf{X}_c'$ .

$$\operatorname{Re} \mathbf{X}_{ACE,k} \begin{cases} \operatorname{Re} \mathbf{X}_{c,k}'' & \text{if } \operatorname{Re} \mathbf{X}_k \text{ is extendable} \\ & \text{AND } |\operatorname{Re} \mathbf{X}_{c,k}''| \geq |\operatorname{Re} \mathbf{X}_k| \\ & \text{AND } \operatorname{Re} \mathbf{X}_{c,k}'' \cdot \operatorname{Re} \mathbf{X}_k \geq 0 \\ \operatorname{Re} \mathbf{X}_k & \text{else} \end{cases}$$

$$\operatorname{Im} \mathbf{X}_{ACE,k} \begin{cases} \operatorname{Im} \mathbf{X}_{c,k}'' & \text{if } \operatorname{Im} \mathbf{X}_k \text{ is extendable} \\ & \text{AND } |\operatorname{Im} \mathbf{X}_{c,k}''| \geq |\operatorname{Im} \mathbf{X}_k| \\ & \text{AND } \operatorname{Im} \mathbf{X}_{c,k}'' \cdot \operatorname{Im} \mathbf{X}_k \geq 0 \\ \operatorname{Im} \mathbf{X}_k & \text{else} \end{cases}$$

$\mathbf{x}_{ACE}$  is obtained from  $\mathbf{X}_{ACE}$  through IFFT.

A component is defined as extendable if it is an active cell (i.e. an OFDM cell carrying a constellation point for L1 signalling or a PLP), and if its absolute amplitude is greater than or equal to the maximal component value associated to the modulation constellation used for that cell; a component is also defined as extendable if it is a dummy cell, a bias balancing cell or an unmodulated cell in the Frame Closing Symbol. As an example, a component belonging to a 256 QAM modulated cell is extendable if its absolute amplitude is greater than or equal to  $\frac{15}{\sqrt{170}}$ .

The value for the gain  $G$  shall be selectable in the range between 0 and 31 in steps of 1.

The clipping threshold  $V_{clip}$  shall be selectable in the range between +0 dB and +12,7 dB in 0,1 dB steps above the standard deviation of the original time-domain signal.

The maximal extension value  $L$  shall be selectable in the range between 0,7 and 1,4 in 0,1 steps.

NOTE: If  $L$  is set to 0,7 there will be no modification of the original signal. When  $L$  is set to its maximum value, the maximal power increase per carrier after extension is obtained for QPSK and bounded to +6 dB.

## 9.6.2 PAPR reduction using tone reservation

The reserved carriers described in clause 9.3 shall not carry data nor L1/L2 signalling, but arbitrary complex values to be used for PAPR reduction.

If the T2\_VERSION field (see clause 7.2.2) is set to a value greater than '0000', and the PAPR field is set to a value of '0000', then 1 iteration only of the tone reservation algorithm specified in clause 9.6.2.1 shall be applied to the P2 symbols, but not to the data symbols.

### 9.6.2.1 Algorithm of PAPR reduction using tone reservation

Signal peaks in the time domain are iteratively cancelled out by a set of impulse-like kernels made using the reserved carriers.

The following definitions will be used in the description of the PAPR reduction algorithm:

- $n$  The sample index,  $0 \leq n < N_{FFT}$ . The sample for which  $n=0$  shall correspond to the beginning of the active symbol period, i.e. to time  $t = mT_F + lT_S + T_{P1} + \Delta$  in the equation of clause 9.5.
- $i$  The iteration index.
- $x_n$  The  $n$ -th sample of the complex baseband time-domain input data signal.
- $x'_n$  The  $n$ -th sample of the complex baseband time-domain output data signal.
- $c_n^{(i)}$  The  $n$ -th sample of the time-domain reduction signal in the  $i$ -th iteration
- $r_k^{(i)}$  The modulation value in the  $i$ -th iteration for the reserved tone whose carrier index is  $k$
- $p_n$  The  $n$ -th sample of the reference kernel signal, defined by:

$$p_n = \frac{1}{N_{TR}} \sum_{k \in S_l} e^{j \frac{2\pi n (k - K_C)}{N_{FFT}}},$$

where  $l$  is the OFDM symbol index and  $S_l$  is the set of reserved carrier indices for symbol  $l$  (see clause 9.3), and  $K_C = \lfloor \frac{K_{\max} + K_{\min}}{2} \rfloor$  is the index  $k$  of the centre ("DC") carrier.

NOTE: The reference kernel corresponds to the inverse Fourier Transform of a  $(N_{FFT}, 1)$  vector  $\mathbf{I}_{TR}$  having  $N_{TR}$  elements of ones at the positions corresponding to the reserved carrier indices  $k \in S_l$

The procedures of the PAPR reduction algorithm are as follows:

#### Initialization:

The initial values for peak reduction signal are set to zeros:

$$c_n^{(0)} = 0, \quad 0 \leq n < N_{FFT}$$

$$r_k^{(0)} = 0, \quad k \in S_l$$

#### Iteration:

- 1)  $i$  starts from 1.
- 2) Find the maximum magnitude of  $x_n + c_n^{(i-1)}$ , denoted by  $y^{(i)}$ , and the corresponding sample index,  $m^{(i)}$  in the  $i$ th iteration.

$$\begin{cases} y^{(i)} = \max_n |x_n + c_n^{(i-1)}| \\ m^{(i)} = \arg \max_n |x_n + c_n^{(i-1)}| \end{cases} \quad \text{for } n = 0, 1, \dots, N_{FFT} - 1,$$



If  $y^{(i)}$  is less than or equal to a desired clipping magnitude level,  $V_{clip}$  then decrease  $i$  by 1 and go to the step 9.

- 3) Calculate a unit-magnitude phasor  $u^{(i)}$  in the direction of the peak to be cancelled:

$$u^{(i)} = \frac{x_{m^{(i)}} + c_{m^{(i)}}^{(i-1)}}{y^{(i)}}$$

- 4) For each reserved tone, calculate the maximum magnitude of correction  $\alpha_k^{(i)}$  that can be applied without causing the reserved carrier amplitude to exceed the maximum allowed value  $A_{\max} = \frac{5\sqrt{10} \times N_{TR}}{\sqrt{27K_{\text{total}}}}$  as follows:

$$\alpha_k^{(i)} = \sqrt{A_{\max}^2 - \text{Im} \left\{ \left( \left( \begin{matrix} (i) \\ k \end{matrix} \right) \right)^* J_k^{(i-1)} \right\}^2 + \text{Re} \left\{ \left( \begin{matrix} (i) \\ k \end{matrix} \right) \right)^* J_k^{(i-1)} \right\}}$$

$$\text{where } v_k^{(i)} = u^{(i)} \exp \left( -\frac{j2\pi \left( \begin{matrix} (i) \\ k \end{matrix} \right) - K_C \right) m^{(i)}}{N_{FFT}} \right)$$

- 5) Find  $\alpha^{(i)}$ , the largest magnitude of correction allowed without causing any reserved carrier amplitudes to exceed  $A_{\max}$ :

$$\alpha^{(i)} = \min \left( y^{(i)} - V_{clip}, \min_{k \in S_I} \alpha_k^{(i)} \right)$$

If  $\alpha^{(i)} = 0$ , then decrease  $i$  by 1 and go to step 9.

- 6) Update the peak reduction signal  $c_n^{(i)}$  by subtracting the reference kernel signal, scaled and cyclically shifted by  $m^{(i)}$ :

$$c_n^{(i)} = c_n^{(i-1)} - \alpha^{(i)} u^{(i)} p_{(n-m^{(i)}) \bmod N_{FFT}}$$

- 7) Update the frequency domain coefficient for each reserved tone  $k \in S_I$ :

$$r_k^{(i)} = r_k^{(i-1)} - \alpha^{(i)} v_k^{(i)},$$

NOTE: If only 1 iteration is required, step 7 can be omitted, and steps 4 and 5 reduce to the following:

$$\alpha^{(1)} = \min(y^{(1)} - V_{clip}, A_{\max}).$$

- 8) If  $i$  is less than a maximum allowed number of iterations, increase  $i$  by 1 and return to step 2. Otherwise, go to step 9.
- 9) Terminate the iterations. The transmitted signal,  $x'_n$  is obtained by adding the peak reduction signal to the data signal:

$$x'_n = x_n + c_n^{(i)}$$

## 9.7 Guard interval insertion

Seven different guard interval fractions ( $\Delta/T_u$ ) are defined. Table 67 gives the absolute guard interval duration  $\Delta$ , expressed in multiples of the elementary period  $T$  (see clause 9.5) for each combination of FFT size and guard interval fraction. Some combinations of guard interval fraction and FFT size shall not be used and are marked 'NA' in table 67.

**Table 67: Duration of the guard interval in terms of the elementary period  $T$**

FFT size	Guard interval fraction ( $\Delta/T_u$ )						
	1/128	1/32	1/16	19/256	1/8	19/128	1/4
32K	256T	1 024T	2 048T	2 432T	4 096T	4 864T	NA
16K	128T	512T	1 024T	1 216T	2 048T	2 432T	4 096T
8K	64T	256T	512T	608T	1 024T	1 216T	2 048T
4K	NA	128T	256T	NA	512T	NA	1 024T
2K	NA	64T	128T	NA	256T	NA	512T
1K	NA	NA	64T	NA	128T	NA	256T

NOTE: There are further restrictions on the combinations of FFT size and guard interval allowed for T2-Lite – see annex I.

The emitted signal, as described in clause 9.5, includes the insertion of guard intervals when PAPR reduction is not used. If PAPR reduction is used, the guard intervals shall be inserted following PAPR reduction.

## 9.8 P1 Symbol insertion

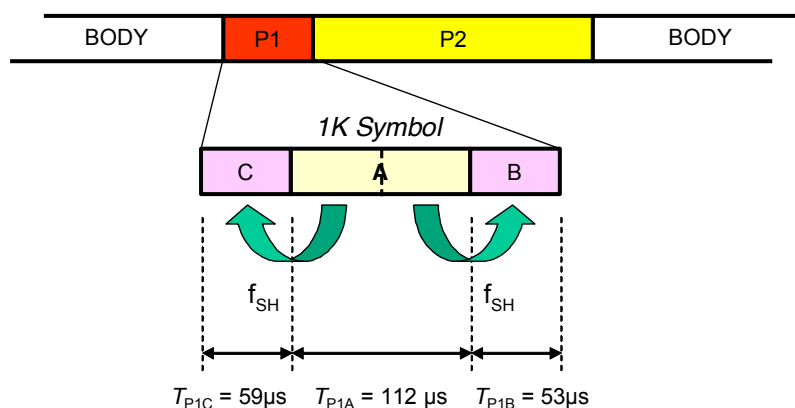
### 9.8.1 P1 Symbol overview

Preamble symbol P1 has four main purposes. First it is used during the initial signal scan for fast recognition of the T2 signal, for which just the detection of the P1 is enough. Construction of the symbol is such that any frequency offsets can be detected directly even if the receiver is tuned to the nominal centre frequency. This saves scanning time as the receiver does not have to test all the possible offsets separately.

The second purpose for P1 is to identify the preamble itself as a T2 preamble. The P1 symbol is such that it can be used to distinguish itself from other formats used in the FEF parts coexisting in the same super-frame. The third task is to signal basic TX parameters that are needed to decode the rest of the preamble which can help during the initialization process. The fourth purpose of P1 is to enable the receiver to detect and correct frequency and timing synchronization.

### 9.8.2 P1 Symbol description

P1 is a 1K OFDM symbol with two 1/2 "guard interval-like" portions added. The total symbol lasts 224  $\mu$ s in 8 MHz system, comprising 112  $\mu$ s, the duration of the useful part 'A' of the symbol plus two modified 'guard-interval' sections 'C' and 'B' of roughly 59  $\mu$ s (542 samples) and 53  $\mu$ s (482 samples), see figure 51.



**Figure 51: P1 symbol structure**

Out of the 853 useful carriers of a 1K symbol, only 384 are used, leaving others set to zero. The used carriers occupy roughly 6,83 MHz band from the middle of the nominal 7,61 MHz signal bandwidth. Design of the symbol is such that even if a maximum offset of 500 kHz is used, most of the used carriers in P1 symbol are still within the 7,61 MHz nominal bandwidth and the symbol can be recovered with the receiver tuned to nominal centre frequency. The first active carrier corresponds to 44, while the last one is 809 (see figure 52).

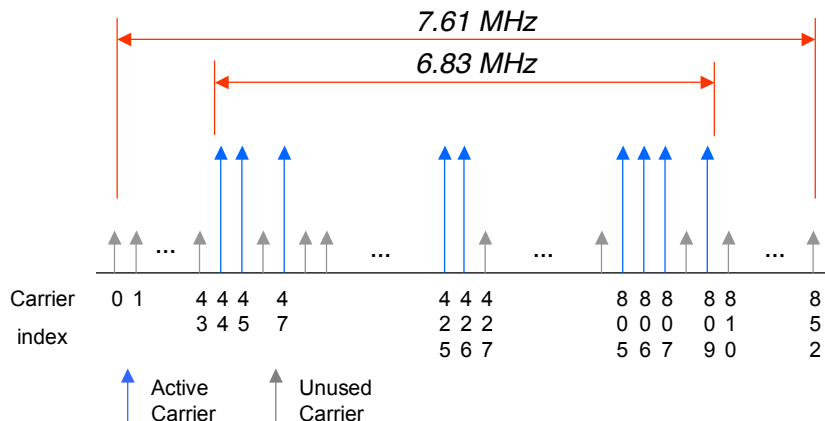


Figure 52: Active carriers of the P1 symbol

The scheme in figure 53 shows how the P1 symbol is generated. Later clauses describe each functional step in detail.

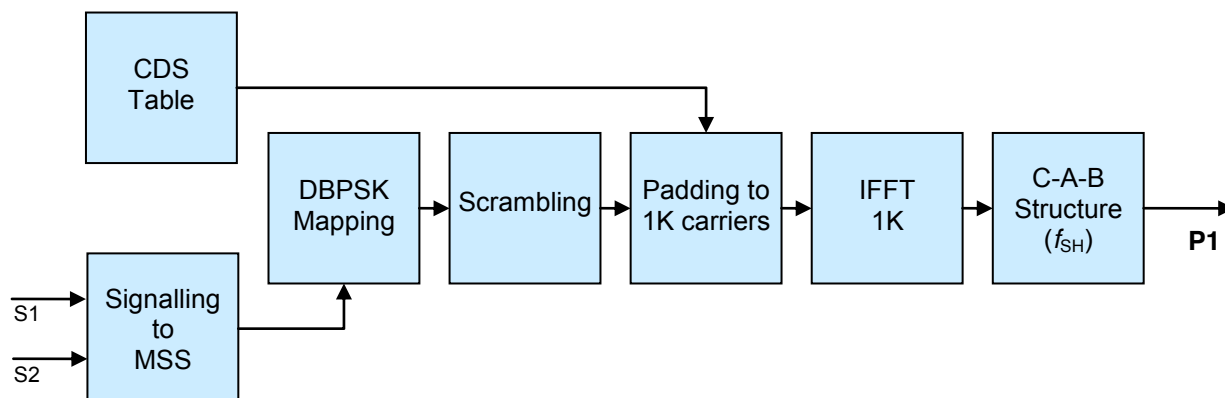


Figure 53: Block diagram of the P1 symbol generation

### 9.8.2.1 Carrier Distribution in P1 symbol

The active carriers are distributed using the following algorithm: out of the 853 carriers of the 1K symbol, the 766 carriers from the middle are considered. From these 766 carriers, only 384 carry pilots; the others are set to zero. In order to identify which of the 766 carriers are active, three complementary sequences are concatenated: the length of the two sequences at the ends is 128, while the sequence in the middle is 512 chips long. The last two bits of the third concatenated sequence are zero, resulting in 766 carriers where 384 of them are active carriers.

The resulting carrier distribution is shown in table 68.

Table 68: Distribution of active carriers in the P1 symbol

Modulation Sequence (see clause 9.8.2.2)	Active Carriers in P1 $k_{P1}(0)..k_{P1}(383)$																						
$k_{P1}(0)..k_{P1}(63)$ CSS <sub>S1</sub>	44	45	47	51	54	59	62	64	65	66	70	75	78	80	81	82	84	85	87	88	89	90	
	94	96	97	98	102	107	110	112	113	114	116	117	119	120	121	122	124						
	125	127	131	132	133	135	136	137	138	142	144	145	146	148	149	151							
	152	153	154	158	160	161	162	166	171														
$k_{P1}(64)..k_{P1}(319)$ CSS <sub>S2</sub>	172	173	175	179	182	187	190	192	193	194	198	203	206	208	209	210							
	212	213	215	216	217	218	222	224	225	226	230	235	238	240	241	242							
	244	245	247	248	249	250	252	253	255	259	260	261	263	264	265	266							
	270	272	273	274	276	277	279	280	281	282	286	288	289	290	294	299							
	300	301	303	307	310	315	318	320	321	322	326	331	334	336	337	338							
	340	341	343	344	345	346	350	352	353	354	358	363	364	365	367	371							
	374	379	382	384	385	386	390	395	396	397	399	403	406	411	412	413							
	415	419	420	421	423	424	425	426	428	429	431	435	438	443	446	448							
	449	450	454	459	462	464	465	466	468	469	471	472	473	474	478	480							
	481	482	486	491	494	496	497	498	500	501	503	504	505	506	508	509							
	511	515	516	517	519	520	521	522	526	528	529	530	532	533	535	536							
	537	538	542	544	545	546	550	555	558	560	561	562	564	565	567	568							
	569	570	572	573	575	579	580	581	583	584	585	586	588	589	591	595							
	598	603	604	605	607	611	612	613	615	616	617	618	622	624	625	626							
	628	629	631	632	633	634	636	637	639	643	644	645	647	648	649	650							
	654	656	657	658	660	661	663	664	665	666	670	672	673	674	678	683							
$k_{P1}(320)..k_{P1}(383)$ CSS <sub>S1</sub>	684	689	692	696	698	699	701	702	703	704	706	707	708										
	712	714	715	717	718	719	720	722	723	725	726	727	729										
	733	734	735	736	738	739	740	744	746	747	748	753	756										
	760	762	763	765	766	767	768	770	771	772	776	778	779										
	780	785	788	792	794	795	796	801	805	806	807	809											

### 9.8.2.2 Modulation of the Active Carriers in P1

Active carriers are DBPSK modulated with a modulation pattern. The patterns, described later, encode two signalling fields S1 and S2. Up to 8 values (can encode 3 bits) and 16 values (can encode 4 bits) can be signalled in each field, respectively. Patterns to encode S1 are based on 8 orthogonal sets of 8 complementary sequences of length 8 (total length of each S1 pattern is 64), while patterns to encode S2 are based of 16 orthogonal sets of 16 complementary sequences of length 16 (total length of each S2 pattern is 256).

The two main properties of these patterns are:

- The sum of the auto-correlations (SoAC) of all the sequences of the set is equal to a Kronecker delta, multiplied by  $KN$  factor, being  $K$  the number of the sequences of each set and  $N$  the length of each sequence. In the case of S1  $K=N=8$ ; in the case of S2,  $K=N=16$ .
- Each set of sequences are mutually uncorrelated (also called "mates").

The S1 and S2 modulation patterns are shown in table 69.

**Table 69: S1 and S2 Modulation patterns**

Field	Val	Sequence (Hexadecimal notation)
<b>S1</b>	000	124721741D482E7B
	001	47127421481D7B2E
	010	217412472E7B1D48
	011	742147127B2E481D
	100	1D482E7B12472174
	101	481D7B2E47127421
	110	2E7B1D4821741247
	111	7B2E481D74214712
	<b>S2</b>	0000
0001		4748121D747B212E48471D127B742E2147B712E2748421D148B81DED7B8B2EDE
0010		212E747B121D47482E217B741D12484721D1748412E247B72EDE7B8B1DED48B8
0011		747B212E4748121D7B742E2148471D12748421D147B712E27B8B2EDE48B81DED
0100		1D1248472E217B74121D4748212E747B1DED48B82EDE7B8B12E247B721D17484
0101		48471D127B742E214748121D747B212E48B81DED7B8B2EDE47B712E2748421D1
0110		2E217B741D124847212E747B121D47482EDE7B8B1DED48B821D1748412E247B7
0111		7B742E2148471D12747B212E4748121D7B8B2EDE48B81DED748421D147B712E2
1000		12E247B721D174841DED48B82EDE7B8B121D4748212E747B1D1248472E217B74
1001		47B712E2748421D148B81DED7B8B2EDE4748121D747B212E48471D127B742E21
1010		21D1748412E247B72EDE7B8B1DED48B8212E747B121D47482E217B741D124847
1011		748421D147B712E27B8B2EDE48B81DED747B212E4748121D7B742E2148471D12
1100		1DED48B82EDE7B8B12E247B721D174841D1248472E217B74121D4748212E747B
1101		48B81DED7B8B2EDE47B712E2748421D148471D127B742E214748121D747B212E
1110		2EDE7B8B1DED48B821D1748412E247B72E217B741D124847212E747B121D4748
1111		7B8B2EDE48B81DED748421D147B712E27B742E2148471D12747B212E4748121D

The bit sequences  $CSS_{S1}=(CSS_{S1,0} \dots CSS_{S1,63})$  and  $CSS_{S2}=(CSS_{S2,0} \dots CSS_{S2,255})$  for given values of S1 and S2 respectively is obtained by taking the corresponding hexadecimal sequence from left to right and from MSB to LSB, i.e.  $CSS_{S1,0}$  is the MSB of the first hexadecimal digit and  $CSS_{S1,63}$  is the LSB of the last digit of the S1 sequence.

The final modulation signal is obtained as follows:

- 1) The Modulation sequence is obtained by concatenating the two  $CSS_{S1}$  and  $CSS_{S2}$  sequences; the  $CSS_{S1}$  sequence is attached at both sides of the  $CSS_{S2}$ :

$$\begin{aligned} \{MSS\_SEQ_0 \dots MSS\_SEQ_{383}\} &= \{CSS_{S1}, CSS_{S2}, CSS_{S1}\} \\ &= \{CSS_{S1,0}, \dots, CSS_{S1,63}, CSS_{S2,0}, \dots, CSS_{S2,255}, CSS_{S1,0}, \dots, CSS_{S1,63}\} \end{aligned}$$

- 2) Then, the sequence is modulated using DBPSK:

$$MSS\_DIFF = DBPSK(MSS\_SEQ)$$

The following rule applies for the differential modulation of element  $i$  of the  $MSS\_SEQ$ :

$$MSS\_DIFF_i = \begin{cases} MSS\_DIFF_{i-1} & MSS\_SEQ_i = 0 \\ -MSS\_DIFF_{i-1} & MSS\_SEQ_i = 1 \end{cases}$$

The differential encoding is started from "dummy" value of +1, i.e.  $MSS\_DIFF_{-1} = +1$  by definition. This bit is not applied to any carrier.

- 3) A scrambling is applied on the  $MSS\_DIFF$  by bit-by-bit multiplying by a 384-bit scrambler sequence:

$$MSS\_SCR = SCRAMBLING \{MSS\_DIFF\}$$

The scrambler sequence shall be equal to the 384-length sequence of '+1' or '-1' converted from the first 384 bits ( $PRBS_0 \dots PRBS_{383}$ ) of the PRBS generator described in clause 5.2.4 with initial state '100111001000110', where a PRBS generator output bit with a value of '0' is converted into '+1' and a PRBS generator output bit with a value of '1' is converted into '-1'.

$$MSS\_SCR_i = MSS\_DIFF_i \times 2 \left( \frac{1}{2} - PRBS_i \right)$$

4) The scrambled modulation pattern is applied to the active carriers.

EXAMPLE: If  $S1=000$  and  $S2=0000$ , then:

The sequence is:

$$\begin{aligned} MSS\_SEQ &= \underbrace{1247\dots2E7B}_{CSS_{S1}}, \underbrace{121D\dots7B8B}_{CSS_{S2}}, \underbrace{1247\dots2E7B}_{CSS_{S1}} \\ &= \underbrace{0,0,1,\dots,1,0,1,1}_{CSS_{S1}}, \underbrace{0,0,0,1,\dots,1,0,1,1}_{CSS_{S2}}, \underbrace{0,0,0,1,\dots,1,0,1,1}_{CSS_{S1}} \end{aligned}$$

Then, DBPSK is applied:

$$MSS\_DIFF = \underbrace{1,1,-1,\dots,1,1,-1,1}_{CSS_{S1}}, \underbrace{1,1,1,-1,\dots,1,1,-1,1}_{CSS_{S2}}, \underbrace{1,1,1,-1,\dots,1,1,-1,1}_{CSS_{S1}}$$

The DBPSK output is scrambled by the scrambling sequence,  $SCR\_SEQ$ .

$$\begin{aligned} SCR\_SEQ &= 2 \left( \frac{1}{2} - PRBS_i \right) \\ &= \underbrace{-1,1,-1,1,\dots,-1,-1,1,1}_{64}, \underbrace{-1,-1,-1,-1,\dots,1,-1,-1,1}_{256}, \underbrace{1,1,-1,-1,\dots,1,1,-1,1}_{64} \end{aligned}$$

after scrambling:

$$MSS\_SCR = \underbrace{-1,1,-1,-1,\dots,-1,-1,-1,1}_{CSS_{S1}}, \underbrace{-1,-1,-1,1,\dots,1,-1,1,1}_{CSS_{S2}}, \underbrace{1,1,-1,1,\dots,1,1,1,1}_{CSS_{S1}}$$

The scrambled modulation MSS is mapped to the active carriers, MSB first:

$$\begin{aligned} c_{44} &= -1, c_{45} = 1, c_{47} = -1, c_{51} = -1, \dots, c_{171} = 1 \\ c_{172} &= -1, c_{173} = -1, c_{175} = -1, \dots, c_{683} = 1 \\ c_{684} &= 1, \dots, c_{805} = 1, c_{806} = 1, c_{807} = 1, c_{809} = 1 \end{aligned}$$

where  $c_k$  is the modulation applied to carrier  $k$ .

The equation for the modulation of the P1 carriers is given in clause 9.8.2.4.

### 9.8.2.3 Boosting of the Active Carriers

Taking into account that in a 1K OFDM symbol only 853 carriers are used, and in P1 there are only 384 active carriers, the boosting applied to the P1 active carriers is a voltage ratio of  $\sqrt{(853/384)}$  or 3,47 dB, relative to the mean value of all  $K_{total}$  of the used carriers of a 1K normal symbol.

## 9.8.2.4 Generation of the time domain P1 signal

### 9.8.2.4.1 Generation of the main part of the P1 signal

The useful part 'A' of the P1 signal is generated from the carrier modulation values, according to the following equation:

$$p_{1A}(t) = \frac{1}{\sqrt{384}} \sum_{i=0}^{383} MSS\_SCR_i \times e^{j2\pi \frac{k_{p1}(i)-426}{1024T} t}$$

where  $k_{p1}(i)$  for  $i=0,1,\dots,383$  are the indices of the 384 active carriers, in increasing order, as defined in clause 9.8.2.1.  $MSS\_SCR_i$  for  $i=0,1,\dots,383$  are the modulation values for the active carriers as defined in clause 9.8.2.2, and  $T$  is the elementary time period and is defined in table 65.

NOTE: This equation, taken together with the equation in clause 9.5, includes the effect of the boosting described in clause 9.8.2.3, which ensures the power of the P1 symbol is virtually the same as the power of the remaining symbols.

### 9.8.2.4.2 Frequency Shifted repetition in Guard Intervals

In order to improve the robustness of the P1, two guard intervals are defined at both sides of the useful part of the symbol. Instead of cyclic continuation like normal OFDM symbols, a frequency shift version of the symbol is used. Thus, denoting P1[C], the first guard interval, P1[A] the main part of the symbol and P1[B] the last guard interval of the symbol, P1[C] carries the frequency shifted version of the first 542T of P1[A], while P1[B] conveys the frequency shifted version of the last 482T of P1[A] (see figure 51).

The frequency shift  $f_{SH}$  applied to P1[C] and P1[B] is:

$$f_{SH} = 1/(1024T)$$

The time-domain baseband waveform  $p_1(t)$  of the P1 symbol is therefore defined as follows:

$$p_1(t) = \begin{cases} p_{1A}(t) e^{j\frac{2\pi}{1024T}t} & 0 \leq t < 542T \\ p_{1A}(t-542T) & 542T \leq t < 1566T \\ p_{1A}(t-1024T) e^{j\frac{2\pi}{1024T}t} & 1566 \leq t < 2048T \\ 0 & \text{otherwise} \end{cases}$$

## 10 Spectrum characteristics

The OFDM symbols constitute a juxtaposition of equally-spaced orthogonal carriers. The amplitudes and phases of the data cell carriers are varying symbol by symbol according to the mapping process previously described.

The power spectral density  $P_{k'}(f)$  of each carrier at frequency:

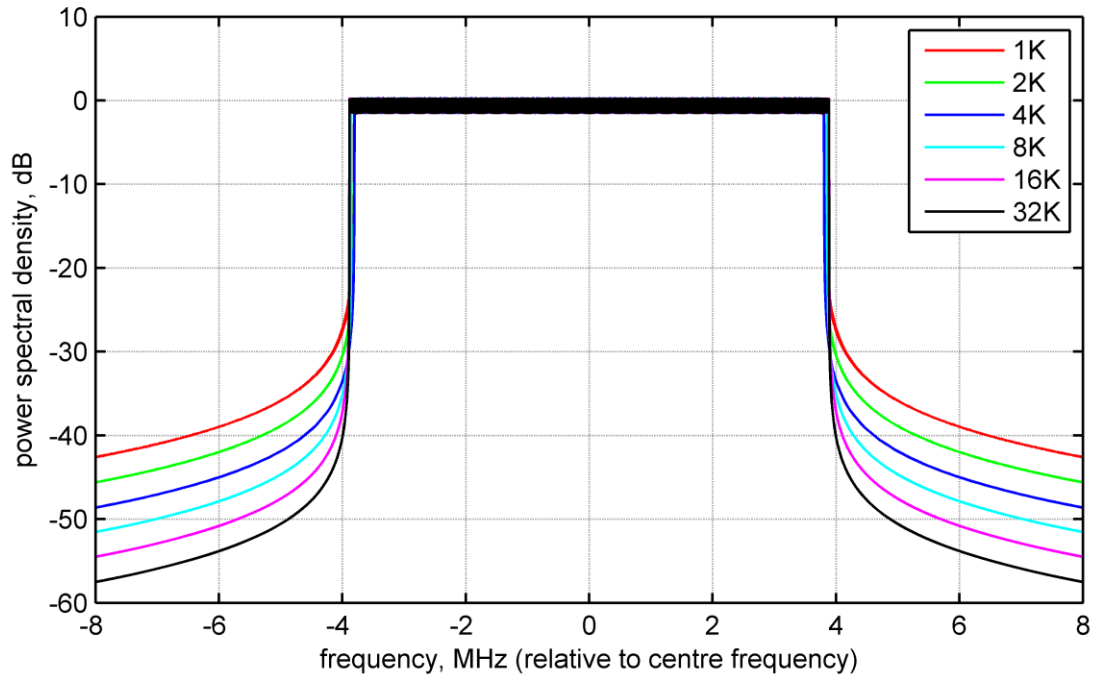
$$f_{k'} = f_c + \frac{k'}{T_u} \text{ for } \left( -\frac{K_{total}-1}{2} \right) \leq k' \leq \frac{K_{total}-1}{2}$$

is defined by the following expression:

$$P_{k'}(f) = \left[ \frac{\sin \pi(f - f_{k'})T_s}{\pi(f - f_{k'})T_s} \right]^2$$

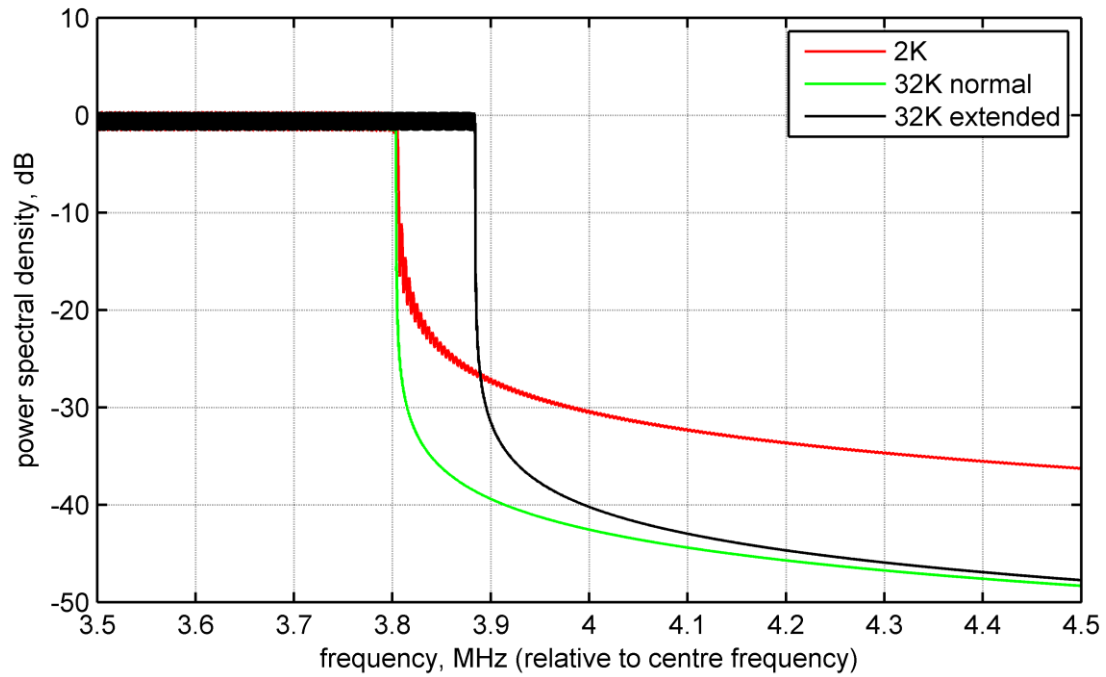
The overall power spectral density of the modulated data cell carriers is the sum of the power spectral densities of all these carriers. A theoretical DVB transmission signal spectrum is illustrated in figure 54 (for 8 MHz channels). Because the OFDM symbol duration is larger than the inverse of the carrier spacing, the main lobe of the power spectral density of each carrier is narrower than twice the carrier spacing. Therefore the spectral density is not constant within the nominal bandwidth.

NOTE 1: This theoretical spectrum takes no account of the variations in power from carrier to carrier caused by the boosting of the pilot carriers.



**Figure 54(a): Theoretical DVB-T2 signal spectrum for guard interval fraction 1/8 (for 8 MHz channels and with extended carrier mode for 8K, 16K and 32K)**





**Figure 54(b): Detail of theoretical DVB-T2 spectrum for guard interval fraction 1/8 (for 8 MHz channels)**

No specific requirements are set in terms of the spectrum characteristics after amplification and filtering, since it is considered to be more appropriately defined by the relevant national or international authority, depending on both the region and the frequency band in which the T2 system is to be deployed.

NOTE 2: The use of PAPR reduction techniques described here can significantly help to reduce the level of out-of-band emissions following high power amplification. It is assumed that these techniques are likely to be needed when the extended carrier modes are being used.

## Annex A (normative): Addresses of parity bit accumulators for $N_{\text{dpc}} = 64\ 800$

Example of interpretation of the table A.1.

$$P_{54} = P_{54} \oplus i_0 \quad P_{9318} = P_{9318} \oplus i_0 \quad P_{14392} = P_{14392} \oplus i_0 \quad P_{27567} = P_{27567} \oplus i_0 \quad P_{26907} = P_{26907} \oplus i_0$$

$$P_{10217} = P_{10217} \oplus i_0 \quad P_{25347} = P_{25347} \oplus i_0 \quad P_{8597} = P_{8597} \oplus i_0$$

$$P_{144} = P_{144} \oplus i_1 \quad P_{9408} = P_{9408} \oplus i_1 \quad P_{14482} = P_{14482} \oplus i_1 \quad P_{27657} = P_{27657} \oplus i_1 \quad P_{26997} = P_{26997} \oplus i_1$$

$$P_{10307} = P_{10307} \oplus i_1 \quad P_{2624} = P_{2624} \oplus i_1 \quad P_{8687} = P_{8687} \oplus i_1$$

: : : : : : : :

: : : : : : : :

$$P_{32364} = P_{32364} \oplus i_{359} \quad P_{9228} = P_{9228} \oplus i_{359} \quad P_{14302} = P_{14302} \oplus i_{359} \quad P_{27477} = P_{27477} \oplus i_{359} \quad P_{26817} = P_{26817} \oplus i_{359}$$

$$P_{10129} = P_{10129} \oplus i_{359} \quad P_{24447} = P_{24447} \oplus i_{359} \quad P_{8507} = P_{8507} \oplus i_{359}$$

$$P_{55} = P_{55} \oplus i_{360} \quad P_{7263} = P_{7263} \oplus i_{360} \quad P_{4635} = P_{4635} \oplus i_{360} \quad P_{2530} = P_{2530} \oplus i_{360} \quad P_{28137} = P_{28137} \oplus i_{360}$$

$$P_{3033} = P_{3033} \oplus i_{360} \quad P_{23837} = P_{23837} \oplus i_{360} \quad P_{3651} = P_{3651} \oplus i_{360}$$

: : : : : : : :

: : : : : : : :

Table A.1: Rate 1/2 ( $N_{ldpc} = 64\ 800$ )

54 9318 14392 27561 26909 10219 2534 8597	20 19978 27197
55 7263 4635 2530 28130 3033 23830 3651	21 27060 15071
56 24731 23583 26036 17299 5750 792 9169	22 6071 26649
57 5811 26154 18653 11551 15447 13685 16264	23 10393 11176
58 12610 11347 28768 2792 3174 29371 12997	24 9597 13370
59 16789 16018 21449 6165 21202 15850 3186	25 7081 17677
60 31016 21449 17618 6213 12166 8334 18212	26 1433 19513
61 22836 14213 11327 5896 718 11727 9308	27 26925 9014
62 2091 24941 29966 23634 9013 15587 5444	28 19202 8900
63 22207 3983 16904 28534 21415 27524 25912	29 18152 30647
64 25687 4501 22193 14665 14798 16158 5491	30 20803 1737
65 4520 17094 23397 4264 22370 16941 21526	31 11804 25221
66 10490 6182 32370 9597 30841 25954 2762	32 31683 17783
67 22120 22865 29870 15147 13668 14955 19235	33 29694 9345
68 6689 18408 18346 9918 25746 5443 20645	34 12280 26611
69 29982 12529 13858 4746 30370 10023 24828	35 6526 26122
70 1262 28032 29888 13063 24033 21951 7863	36 26165 11241
71 6594 29642 31451 14831 9509 9335 31552	37 7666 26962
72 1358 6454 16633 20354 24598 624 5265	38 16290 8480
73 19529 295 18011 3080 13364 8032 15323	39 11774 10120
74 11981 1510 7960 21462 9129 11370 25741	40 30051 30426
75 9276 29656 4543 30699 20646 21921 28050	41 1335 15424
76 15975 25634 5520 31119 13715 21949 19605	42 6865 17742
77 18688 4608 31755 30165 13103 10706 29224	43 31779 12489
78 21514 23117 12245 26035 31656 25631 30699	44 32120 21001
79 9674 24966 31285 29908 17042 24588 31857	45 14508 6996
80 21856 27777 29919 27000 14897 11409 7122	46 979 25024
81 29773 23310 263 4877 28622 20545 22092	47 4554 21896
82 15605 5651 21864 3967 14419 22757 15896	48 7989 21777
83 30145 1759 10139 29223 26086 10556 5098	49 4972 20661
84 18815 16575 2936 24457 26738 6030 505	50 6612 2730
85 30326 22298 27562 20131 26390 6247 24791	51 12742 4418
86 928 29246 21246 12400 15311 32309 18608	52 29194 595
87 20314 6025 26689 16302 2296 3244 19613	53 19267 20113
88 6237 11943 22851 15642 23857 15112 20947	
89 26403 25168 19038 18384 8882 12719 7093	
0 14567 24965	
1 3908 100	
2 10279 240	
3 24102 764	
4 12383 4173	
5 13861 15918	
6 21327 1046	
7 5288 14579	
8 28158 8069	
9 16583 11098	
10 16681 28363	
11 13980 24725	
12 32169 17989	
13 10907 2767	
14 21557 3818	
15 26676 12422	
16 7676 8754	
17 14905 20232	
18 15719 24646	
19 31942 8589	

Table A.2: Rate 3/5 ( $N_{ldpc} = 64\ 800$ )

22422 10282 11626 19997 11161 2922 3122 99 5625 17064 8270 179	16 6079 21122
25087 16218 17015 828 20041 25656 4186 11629 22599 17305 22515 6463	17 22782 5828
11049 22853 25706 14388 5500 19245 8732 2177 13555 11346 17265 3069	18 19775 4247
16581 22225 12563 19717 23577 11555 25496 6853 25403 5218 15925 21766	19 1660 19413
16529 14487 7643 10715 17442 11119 5679 14155 24213 21000 1116 15620	20 4403 3649
5340 8636 16693 1434 5635 6516 9482 20189 1066 15013 25361 14243	21 13371 25851
18506 22236 20912 8952 5421 15691 6126 21595 500 6904 13059 6802	22 22770 21784
8433 4694 5524 14216 3685 19721 25420 9937 23813 9047 25651 16826	23 10757 14131
21500 24814 6344 17382 7064 13929 4004 16552 12818 8720 5286 2206	24 16071 21617
22517 2429 19065 2921 21611 1873 7507 5661 23006 23128 20543 19777	25 6393 3725
1770 4636 20900 14931 9247 12340 11008 12966 4471 2731 16445 791	26 597 19968
6635 14556 18865 22421 22124 12697 9803 25485 7744 18254 11313 9004	27 5743 8084
19982 23963 18912 7206 12500 4382 20067 6177 21007 1195 23547 24837	28 6770 9548
756 11158 14646 20534 3647 17728 11676 11843 12937 4402 8261 22944	29 4285 17542
9306 24009 10012 11081 3746 24325 8060 19826 842 8836 2898 5019	30 13568 22599
7575 7455 25244 4736 14400 22981 5543 8006 24203 13053 1120 5128	31 1786 4617
3482 9270 13059 15825 7453 23747 3656 24585 16542 17507 22462 14670	32 23238 11648
15627 15290 4198 22748 5842 13395 23918 16985 14929 3726 25350 24157	33 19627 2030
24896 16365 16423 13461 16615 8107 24741 3604 25904 8716 9604 20365	34 13601 13458
3729 17245 18448 9862 20831 25326 20517 24618 13282 5099 14183 8804	35 13740 17328
16455 17646 15376 18194 25528 1777 6066 21855 14372 12517 4488 17490	36 25012 13944
1400 8135 23375 20879 8476 4084 12936 25536 22309 16582 6402 24360	37 22513 6687
25119 23586 128 4761 10443 22536 8607 9752 25446 15053 1856 4040	38 4934 12587
377 21160 13474 5451 17170 5938 10256 11972 24210 17833 22047 16108	39 21197 5133
13075 9648 24546 13150 23867 7309 19798 2988 16858 4825 23950 15125	40 22705 6938
20526 3553 11525 23366 2452 17626 19265 20172 18060 24593 13255 1552	41 7534 24633
18839 21132 20119 15214 14705 7096 10174 5663 18651 19700 12524 14033	42 24400 12797
4127 2971 17499 16287 22368 21463 7943 18880 5567 8047 23363 6797	43 21911 25712
10651 24471 14325 4081 7258 4949 7044 1078 797 22910 20474 4318	44 12039 1140
21374 13231 22985 5056 3821 23718 14178 9978 19030 23594 8895 25358	45 24306 1021
6199 22056 7749 13310 3999 23697 16445 22636 5225 22437 24153 9442	46 14012 20747
7978 12177 2893 20778 3175 8645 11863 24623 10311 25767 17057 3691	47 11265 15219
20473 11294 9914 22815 2574 8439 3699 5431 24840 21908 16088 18244	48 4670 15531
8208 5755 19059 8541 24924 6454 11234 10492 16406 10831 11436 9649	49 9417 14359
16264 11275 24953 2347 12667 19190 7257 7174 24819 2938 2522 11749	50 2415 6504
3627 5969 13862 1538 23176 6353 2855 17720 2472 7428 573 15036	51 24964 24690
0 18539 18661	52 14443 8816
1 10502 3002	53 6926 1291
2 9368 10761	54 6209 20806
3 12299 7828	55 13915 4079
4 15048 13362	56 24410 13196
5 18444 24640	57 13505 6117
6 20775 19175	58 9869 8220
7 18970 10971	59 1570 6044
8 5329 19982	60 25780 17387
9 11296 18655	61 20671 24913
10 15046 20659	62 24558 20591
11 7300 22140	63 12402 3702
12 22029 14477	64 8314 1357
13 11129 742	65 20071 14616
14 13254 13813	66 17014 3688
15 19234 13273	67 19837 946
	68 15195 12136
	69 7758 22808
	70 3564 2925
	71 3434 7769

Table A.3: Rate 2/3 ( $N_{\text{ldpc}} = 64\ 800$ )

317 2255 2324 2723 3538 3576 6194 6700 9101 10057 12739 17407 21039	10574 11268 17932
1958 2007 3294 4394 12762 14505 14593 14692 16522 17737 19245 21272 21379	15442 17266 20482
127 860 5001 5633 8644 9282 12690 14644 17553 19511 19681 20954 21002	390 3371 8781
2514 2822 5781 6297 8063 9469 9551 11407 11837 12985 15710 20236 20393	10512 12216 17180
1565 3106 4659 4926 6495 6872 7343 8720 15785 16434 16727 19884 21325	4309 14068 15783
706 3220 8568 10896 12486 13663 16398 16599 19475 19781 20625 20961 21335	3971 11673 20009
4257 10449 12406 14561 16049 16522 17214 18029 18033 18802 19062 19526 20748	9259 14270 17199
412 433 558 2614 2978 4157 6584 9320 11683 11819 13024 14486 16860	2947 5852 20101
777 5906 7403 8550 8717 8770 11436 12846 13629 14755 15688 16392 16419	3965 9722 15363
4093 5045 6037 7248 8633 9771 10260 10809 11326 12072 17516 19344 19938	1429 5689 16771
2120 2648 3155 3852 6888 12258 14821 15359 16378 16437 17791 20614 21025	6101 6849 12781
1085 2434 5816 7151 8050 9422 10884 12728 15353 17733 18140 18729 20920	3676 9347 18761
856 1690 12787	350 11659 18342
6532 7357 9151	5961 14803 16123
4210 16615 18152	2113 9163 13443
11494 14036 17470	2155 9808 12885
2474 10291 10323	2861 7988 11031
1778 6973 10739	7309 9220 20745
4347 9570 18748	6834 8742 11977
2189 11942 20666	2133 12908 14704
3868 7526 17706	10170 13809 18153
8780 14796 18268	13464 14787 14975
160 16232 17399	799 1107 3789
1285 2003 18922	3571 8176 10165
4658 17331 20361	5433 13446 15481
2765 4862 5875	3351 6767 12840
4565 5521 8759	8950 8974 11650
3484 7305 15829	1430 4250 21332
5024 17730 17879	6283 10628 15050
7031 12346 15024	8632 14404 16916
179 6365 11352	6509 10702 16278
2490 3143 5098	15900 16395 17995
2643 3101 21259	8031 18420 19733
4315 4724 13130	3747 4634 17087
594 17365 18322	4453 6297 16262
5983 8597 9627	2792 3513 17031
10837 15102 20876	14846 20893 21563
10448 20418 21478	17220 20436 21337
3848 12029 15228	275 4107 10497
708 5652 13146	3536 7520 10027
5998 7534 16117	14089 14943 19455
2098 13201 18317	1965 3931 21104
9186 14548 17776	2439 11565 17932
5246 10398 18597	154 15279 21414
3083 4944 21021	10017 11269 16546
13726 18495 19921	7169 10161 16928
6736 10811 17545	10284 16791 20655
10084 12411 14432	36 3175 8475
1064 13555 17033	2605 16269 19290
679 9878 13547	8947 9178 15420
3422 9910 20194	5687 9156 12408
3640 3701 10046	8096 9738 14711
5862 10134 11498	4935 8093 19266
5923 9580 15060	2667 10062 15972
1073 3012 16427	6389 11318 14417
5527 20113 20883	8800 18137 18434
7058 12924 15151	5824 5927 15314
9764 12230 17375	6056 13168 15179
772 7711 12723	3284 13138 18919
555 13816 15376	13115 17259 17332

Table A.4: Rate 3/4 ( $N_{\text{ldpc}} = 64\ 800$ )

0 6385 7901 14611 13389 11200 3252 5243 2504 2722 821 7374	23 5865 1768
1 11359 2698 357 13824 12772 7244 6752 15310 852 2001 11417	24 2655 14957
2 7862 7977 6321 13612 12197 14449 15137 13860 1708 6399 13444	25 5565 6332
3 1560 11804 6975 13292 3646 3812 8772 7306 5795 14327 7866	26 4303 12631
4 7626 11407 14599 9689 1628 2113 10809 9283 1230 15241 4870	27 11653 12236
5 1610 5699 15876 9446 12515 1400 6303 5411 14181 13925 7358	28 16025 7632
6 4059 8836 3405 7853 7992 15336 5970 10368 10278 9675 4651	29 4655 14128
7 4441 3963 9153 2109 12683 7459 12030 12221 629 15212 406	30 9584 13123
8 6007 8411 5771 3497 543 14202 875 9186 6235 13908 3563	31 13987 9597
9 3232 6625 4795 546 9781 2071 7312 3399 7250 4932 12652	32 15409 12110
10 8820 10088 11090 7069 6585 13134 10158 7183 488 7455 9238	33 8754 15490
11 1903 10818 119 215 7558 11046 10615 11545 14784 7961 15619	34 7416 15325
12 3655 8736 4917 15874 5129 2134 15944 14768 7150 2692 1469	35 2909 15549
13 8316 3820 505 8923 6757 806 7957 4216 15589 13244 2622	36 2995 8257
14 14463 4852 15733 3041 11193 12860 13673 8152 6551 15108 8758	37 9406 4791
15 3149 11981	38 11111 4854
16 13416 6906	39 2812 8521
17 13098 13352	40 8476 14717
18 2009 14460	41 7820 15360
19 7207 4314	42 1179 7939
20 3312 3945	43 2357 8678
21 4418 6248	44 7703 6216
22 2669 13975	0 3477 7067
23 7571 9023	1 3931 13845
24 14172 2967	2 7675 12899
25 7271 7138	3 1754 8187
26 6135 13670	4 7785 1400
27 7490 14559	5 9213 5891
28 8657 2466	6 2494 7703
29 8599 12834	7 2576 7902
30 3470 3152	8 4821 15682
31 13917 4365	9 10426 11935
32 6024 13730	10 1810 904
33 10973 14182	11 11332 9264
34 2464 13167	12 11312 3570
35 5281 15049	13 14916 2650
36 1103 1849	14 7679 7842
37 2058 1069	15 6089 13084
38 9654 6095	16 3938 2751
39 14311 7667	17 8509 4648
40 15617 8146	18 12204 8917
41 4588 11218	19 5749 12443
42 13660 6243	20 12613 4431
43 8578 7874	21 1344 4014
44 11741 2686	22 8488 13850
0 1022 1264	23 1730 14896
1 12604 9965	24 14942 7126
2 8217 2707	25 14983 8863
3 3156 11793	26 6578 8564
4 354 1514	27 4947 396
5 6978 14058	28 297 12805
6 7922 16079	29 13878 6692
7 15087 12138	30 11857 11186
8 5053 6470	31 14395 11493
9 12687 14932	32 16145 12251
10 15458 1763	33 13462 7428
11 8121 1721	34 14526 13119
12 12431 549	35 2535 11243
13 4129 7091	36 6465 12690
14 1426 8415	37 6872 9334
15 9783 7604	38 15371 14023
16 6295 11329	39 8101 10187
17 1409 12061	40 11963 4848
18 8065 9087	41 15125 6119
19 2918 8438	42 8051 14465
20 1293 14115	43 11139 5167
21 3922 13851	44 2883 14521
22 3851 4000	

Table A.5: Rate 4/5 ( $N_{\text{ldpc}} = 64\ 800$ )

0 149 11212 5575 6360 12559 8108 8505 408 10026 12828	0 5647 4935
1 5237 490 10677 4998 3869 3734 3092 3509 7703 10305	1 4219 1870
2 8742 5553 2820 7085 12116 10485 564 7795 2972 2157	2 10968 8054
3 2699 4304 8350 712 2841 3250 4731 10105 517 7516	3 6970 5447
4 12067 1351 11992 12191 11267 5161 537 6166 4246 2363	4 3217 5638
5 6828 7107 2127 3724 5743 11040 10756 4073 1011 3422	5 8972 669
6 11259 1216 9526 1466 10816 940 3744 2815 11506 11573	6 5618 12472
7 4549 11507 1118 1274 11751 5207 7854 12803 4047 6484	7 1457 1280
8 8430 4115 9440 413 4455 2262 7915 12402 8579 7052	8 8868 3883
9 3885 9126 5665 4505 2343 253 4707 3742 4166 1556	9 8866 1224
10 1704 8936 6775 8639 8179 7954 8234 7850 8883 8713	10 8371 5972
11 11716 4344 9087 11264 2274 8832 9147 11930 6054 5455	11 266 4405
12 7323 3970 10329 2170 8262 3854 2087 12899 9497 11700	12 3706 3244
13 4418 1467 2490 5841 817 11453 533 11217 11962 5251	13 6039 5844
14 1541 4525 7976 3457 9536 7725 3788 2982 6307 5997	14 7200 3283
15 11484 2739 4023 12107 6516 551 2572 6628 8150 9852	15 1502 11282
16 6070 1761 4627 6534 7913 3730 11866 1813 12306 8249	16 12318 2202
17 12441 5489 8748 7837 7660 2102 11341 2936 6712 11977	17 4523 965
18 10155 4210	18 9587 7011
19 1010 10483	19 2552 2051
20 8900 10250	20 12045 10306
21 10243 12278	21 11070 5104
22 7070 4397	22 6627 6906
23 12271 3887	23 9889 2121
24 11980 6836	24 829 9701
25 9514 4356	25 2201 1819
26 7137 10281	26 6689 12925
27 11881 2526	27 2139 8757
28 1969 11477	28 12004 5948
29 3044 10921	29 8704 3191
30 2236 8724	30 8171 10933
31 9104 6340	31 6297 7116
32 7342 8582	32 616 7146
33 11675 10405	33 5142 9761
34 6467 12775	34 10377 8138
35 3186 12198	35 7616 5811
0 9621 11445	0 7285 9863
1 7486 5611	1 7764 10867
2 4319 4879	2 12343 9019
3 2196 344	3 4414 8331
4 7527 6650	4 3464 642
5 10693 2440	5 6960 2039
6 6755 2706	6 786 3021
7 5144 5998	7 710 2086
8 11043 8033	8 7423 5601
9 4846 4435	9 8120 4885
10 4157 9228	10 12385 11990
11 12270 6562	11 9739 10034
12 11954 7592	12 424 10162
13 7420 2592	13 1347 7597
14 8810 9636	14 1450 112
15 689 5430	15 7965 8478
16 920 1304	16 8945 7397
17 1253 11934	17 6590 8316
18 9559 6016	18 6838 9011
19 312 7589	19 6174 9410
20 4439 4197	20 255 113
21 4002 9555	21 6197 5835
22 12232 7779	22 12902 3844
23 1494 8782	23 4377 3505
24 10749 3969	24 5478 8672
25 4368 3479	25 4453 2132
26 6316 5342	26 9724 1380
27 2455 3493	27 12131 11526
28 12157 7405	28 12323 9511
29 6598 11495	29 8231 1752
30 11805 4455	30 497 9022
31 9625 2090	31 9288 3080
32 4731 2321	32 2481 7515
33 3578 2608	33 2696 268
34 8504 1849	34 4023 12341
35 4027 1151	35 7108 5553

Table A.6: Rate 5/6 ( $N_{ldpc} = 64\ 800$ )

0 4362 416 8909 4156 3216 3112 2560 2912 6405 8593 4969 6723	20 4766 2697	10 7868 5731
1 2479 1786 8978 3011 4339 9313 6397 2957 7288 5484 6031 10217	21 4069 6675	11 6121 10732
2 10175 9009 9889 3091 4985 7267 4092 8874 5671 2777 2189 8716	22 1117 1016	12 4843 9132
3 9052 4795 3924 3370 10058 1128 9996 10165 9360 4297 434 5138	23 5619 3085	13 580 9591
4 2379 7834 4835 2327 9843 804 329 8353 7167 3070 1528 7311	24 8483 8400	14 6267 9290
5 3435 7871 348 3693 1876 6585 10340 7144 5870 2084 4052 2780	25 8255 394	15 3009 2268
6 3917 3111 3476 1304 10331 5939 5199 1611 1991 699 8316 9960	26 6338 5042	16 195 2419
7 6883 3237 1717 10752 7891 9764 4745 3888 10009 4176 4614 1567	27 6174 5119	17 8016 1557
8 10587 2195 1689 2968 5420 2580 2883 6496 111 6023 1024 4449	28 7203 1989	18 1516 9195
9 3786 8593 2074 3321 5057 1450 3840 5444 6572 3094 9892 1512	29 1781 5174	19 8062 9064
10 8548 1848 10372 4585 7313 6536 6379 1766 9462 2456 5606 9975	0 1464 3559	20 2095 8968
11 8204 10593 7935 3636 3882 394 5968 8561 2395 7289 9267 9978	1 3376 4214	21 753 7326
12 7795 74 1633 9542 6867 7352 6417 7568 10623 725 2531 9115	2 7238 67	22 6291 3833
13 7151 2482 4260 5003 10105 7419 9203 6691 8798 2092 8263 3755	3 10595 8831	23 2614 7844
14 3600 570 4527 200 9718 6771 1995 8902 5446 768 1103 6520	4 1221 6513	24 2303 646
15 6304 7621	5 5300 4652	25 2075 611
16 6498 9209	6 1429 9749	26 4687 362
17 7293 6786	7 7878 5131	27 8684 9940
18 5950 1708	8 4435 10284	28 4830 2065
19 8521 1793	9 6331 5507	29 7038 1363
20 6174 7854	10 6662 4941	0 1769 7837
21 9773 1190	11 9614 10238	1 3801 1689
22 9517 10268	12 8400 8025	2 10070 2359
23 2181 9349	13 9156 5630	3 3667 9918
24 1949 5560	14 7067 8878	4 1914 6920
25 1556 555	15 9027 3415	5 4244 5669
26 8600 3827	16 1690 3866	6 10245 7821
27 5072 1057	17 2854 8469	7 7648 3944
28 7928 3542	18 6206 630	8 3310 5488
29 3226 3762	19 363 5453	9 6346 9666
0 7045 2420	20 4125 7008	10 7088 6122
1 9645 2641	21 1612 6702	11 1291 7827
2 2774 2452	22 9069 9226	12 10592 8945
3 5331 2031	23 5767 4060	13 3609 7120
4 9400 7503	24 3743 9237	14 9168 9112
5 1850 2338	25 7018 5572	15 6203 8052
6 10456 9774	26 8892 4536	16 3330 2895
7 1692 9276	27 853 6064	17 4264 10563
8 10037 4038	28 8069 5893	18 10556 6496
9 3964 338	29 2051 2885	19 8807 7645
10 2640 5087	0 10691 3153	20 1999 4530
11 858 3473	1 3602 4055	21 9202 6818
12 5582 5683	2 328 1717	22 3403 1734
13 9523 916	3 2219 9299	23 2106 9023
14 4107 1559	4 1939 7898	24 6881 3883
15 4506 3491	5 617 206	25 3895 2171
16 8191 4182	6 8544 1374	26 4062 6424
17 10192 6157	7 10676 3240	27 3755 9536
18 5668 3305	8 6672 9489	28 4683 2131
19 3449 1540	9 3170 7457	29 7347 8027



## Annex B (normative): Addresses of parity bit accumulators for $N_{\text{ldpc}} = 16\ 200$

**Table B.1: Rate 1/4 ( $N_{\text{ldpc}} = 16\ 200$ )**

6295 9626 304 7695 4839 4936 1660 144 11203 5567 6347 12557
10691 4988 3859 3734 3071 3494 7687 10313 5964 8069 8296 11090
10774 3613 5208 11177 7676 3549 8746 6583 7239 12265 2674 4292
11869 3708 5981 8718 4908 10650 6805 3334 2627 10461 9285 11120
7844 3079 10773
3385 10854 5747
1360 12010 12202
6189 4241 2343
9840 12726 4977

**Table B.2: Rate 1/2 ( $N_{\text{ldpc}} = 16\ 200$ )**

20 712 2386 6354 4061 1062 5045 5158	5 5924 290
21 2543 5748 4822 2348 3089 6328 5876	6 1467 4049
22 926 5701 269 3693 2438 3190 3507	7 7820 2242
23 2802 4520 3577 5324 1091 4667 4449	8 4606 3080
24 5140 2003 1263 4742 6497 1185 6202	9 4633 7877
0 4046 6934	10 3884 6868
1 2855 66	11 8935 4996
2 6694 212	12 3028 764
3 3439 1158	13 5988 1057
4 3850 4422	14 7411 3450

**Table B.3: Rate 3/5 ( $N_{\text{ldpc}} = 16\ 200$ )**

71 1478 1901 2240 2649 2725 3592 3708 3965 4080 5733 6198	2820 4109 5307
393 1384 1435 1878 2773 3182 3586 5465 6091 6110 6114 6327	2088 5834 5988
160 1149 1281 1526 1566 2129 2929 3095 3223 4250 4276 4612	3725 3945 4010
289 1446 1602 2421 3559 3796 5590 5750 5763 6168 6271 6340	1081 2780 3389
947 1227 2008 2020 2266 3365 3588 3867 4172 4250 4865 6290	659 2221 4822
3324 3704 4447	3033 6060 6160
1206 2565 3089	756 1489 2350
529 4027 5891	3350 3624 5470
141 1187 3206	357 1825 5242
1990 2972 5120	585 3372 6062
752 796 5976	561 1417 2348
1129 2377 4030	971 3719 5567
6077 6108 6231	1005 1675 2062
61 1053 1781	

**Table B.4: Rate 2/3 ( $N_{\text{ldpc}} = 16\ 200$ )**

0 2084 1613 1548 1286 1460 3196 4297 2481 3369 3451 4620 2622	1 2583 1180
1 122 1516 3448 2880 1407 1847 3799 3529 373 971 4358 3108	2 1542 509
2 259 3399 929 2650 864 3996 3833 107 5287 164 3125 2350	3 4418 1005
3 342 3529	4 5212 5117
4 4198 2147	5 2155 2922
5 1880 4836	6 347 2696
6 3864 4910	7 226 4296
7 243 1542	8 1560 487
8 3011 1436	9 3926 1640
9 2167 2512	10 149 2928
10 4606 1003	11 2364 563
11 2835 705	12 635 688
12 3426 2365	13 231 1684
13 3848 2474	14 1129 3894
14 1360 1743	
0 163 2536	

**Table B.5: Rate 3/4 ( $N_{\text{ldpc}} = 16\ 200$ )**

3 3198 478 4207 1481 1009 2616 1924 3437 554 683 1801	8 1015 1945
4 2681 2135	9 1948 412
5 3107 4027	10 995 2238
6 2637 3373	11 4141 1907
7 3830 3449	0 2480 3079
8 4129 2060	1 3021 1088
9 4184 2742	2 713 1379
10 3946 1070	3 997 3903
11 2239 984	4 2323 3361
0 1458 3031	5 1110 986
1 3003 1328	6 2532 142
2 1137 1716	7 1690 2405
3 132 3725	8 1298 1881
4 1817 638	9 615 174
5 1774 3447	10 1648 3112
6 3632 1257	11 1415 2808
7 542 3694	

**Table B.6: Rate 4/5 ( $N_{\text{ldpc}} = 16\ 200$ )**

5 896 1565	3 465 2552
6 2493 184	4 1038 2479
7 212 3210	5 1383 343
8 727 1339	6 94 236
9 3428 612	7 2619 121
0 2663 1947	8 1497 2774
1 230 2695	9 2116 1855
2 2025 2794	0 722 1584
3 3039 283	1 2767 1881
4 862 2889	2 2701 1610
5 376 2110	3 3283 1732
6 2034 2286	4 168 1099
7 951 2068	5 3074 243
8 3108 3542	6 3460 945
9 307 1421	7 2049 1746
0 2272 1197	8 566 1427
1 1800 3280	9 3545 1168
2 331 2308	

**Table B.7: Rate 5/6 ( $N_{\text{ldpc}} = 16\ 200$ )**

3 2409 499 1481 908 559 716 1270 333 2508 2264 1702 2805	6 497 2228
4 2447 1926	7 2326 1579
5 414 1224	0 2482 256
6 2114 842	1 1117 1261
7 212 573	2 1257 1658
0 2383 2112	3 1478 1225
1 2286 2348	4 2511 980
2 545 819	5 2320 2675
3 1264 143	6 435 1278
4 1701 2258	7 228 503
5 964 166	0 1885 2369
6 114 2413	1 57 483
7 2243 81	2 838 1050
0 1245 1581	3 1231 1990
1 775 169	4 1738 68
2 1696 1104	5 2392 951
3 1914 2831	6 163 645
4 532 1450	7 2644 1704
5 91 974	

**Table B.8: Rate 1/3 ( $N_{\text{idpc}} = 16\ 200$ ) – T2-Lite only**

416 8909 4156 3216 3112 2560 2912 6405 8593 4969 6723 6912
8978 3011 4339 9312 6396 2957 7288 5485 6031 10218 2226 3575
3383 10059 1114 10008 10147 9384 4290 434 5139 3536 1965 2291
2797 3693 7615 7077 743 1941 8716 6215 3840 5140 4582 5420
6110 8551 1515 7404 4879 4946 5383 1831 3441 9569 10472 4306
1505 5682 7778
7172 6830 6623
7281 3941 3505
10270 8669 914
3622 7563 9388
9930 5058 4554
4844 9609 2707
6883 3237 1714
4768 3878 10017
10127 3334 8267

**Table B.9: Rate 2/5 ( $N_{\text{idpc}} = 16\ 200$ ) – T2-Lite only**

5650 4143 8750 583 6720 8071 635 1767 1344 6922 738 6658
5696 1685 3207 415 7019 5023 5608 2605 857 6915 1770 8016
3992 771 2190 7258 8970 7792 1802 1866 6137 8841 886 1931
4108 3781 7577 6810 9322 8226 5396 5867 4428 8827 7766 2254
4247 888 4367 8821 9660 324 5864 4774 227 7889 6405 8963
9693 500 2520 2227 1811 9330 1928 5140 4030 4824 806 3134
1652 8171 1435
3366 6543 3745
9286 8509 4645
7397 5790 8972
6597 4422 1799
9276 4041 3847
8683 7378 4946
5348 1993 9186
6724 9015 5646
4502 4439 8474
5107 7342 9442
1387 8910 2660

## Annex C (normative): Additional Mode Adaptation tools

### C.1 Input stream synchronizer

Delays and packet jitter introduced by DVB-T2 modems may depend on the transmitted bit-rate and may change in time during bit and/or code rate switching. The "Input Stream Synchronizer" (see figure C.1) shall provide a mechanism to regenerate, in the receiver, the clock of the Transport Stream (or packetized Generic Stream) at the modulator Mode Adapter input, in order to guarantee end-to-end constant bit rates and delays (see also figure J.1, example receiver implementation). Table C.1 gives the details of the coding of the ISSY field generated by the input stream synchronizer.

When  $ISSYI = 1$  in  $MATYPE$  field (see clause 5.1.7) a counter shall be activated (22 bits), clocked by the modulator sampling rate (frequency  $R_s = 1/T$ , where  $T$  is defined in clause 9.5). The Input Stream SYNchronization field (ISSY, 2 or 3 bytes) shall be transmitted according to clause 5.1.8.

An example receiver scheme to regenerate the output packet stream and the relevant clock  $R'_{IN}$  is given in figure J.1.

ISSY shall be coded according to table C.1, sending the following variables:

- ISCR (short: 15 bits; long: 22 bits) (ISCR = Input Stream Clock Reference), loaded with the LSBs of the counter content at the instant the relevant input packet is processed (at constant rate  $R_{IN}$ ), and specifically the instant the MSB of the relevant packet arrives at the modulator input stream interface. In case of continuous streams the content of the counter is loaded when the MSB of the Data Field is processed.

ISCR shall be transmitted in the third ISSY field of each Interleaving Frame for each PLP. Where applicable, ISCR shall be transmitted in all subsequent ISSY fields of each Interleaving Frame for each PLP. In HEM, for BBFrames for which no UP begins in the Data Field, ISCR is not applicable and BUFS shall be sent instead (see below).

Two successive ISCR values shall not correspond to time instants separated by more than  $2^{15}T$  for  $ISCR_{short}$  or  $2^{22}T$  for  $ISCR_{long}$ . This may be achieved by using Normal Mode and/or transmitting null packets which would normally be deleted, as necessary.

In a given PLP, either  $ISCR_{short}$  or  $ISCR_{long}$  shall be used, together with the short or long versions respectively of BUFS and TTO. A PLP shall not change from short to long ISSY except at a reconfiguration.

In HEM,  $ISCR_{long}$  shall always be used.

- BUFS (2+10 bits) (BUFS = maximum size of the requested receiver buffer to compensate delay variations). This variable indicates the size of the receiver buffer assumed by the modulator for the relevant PLP. It shall have a maximum value of 2 Mbits. When a group of data PLPs share a common PLP, the sum of the buffer size for any data PLP in the group plus the buffer size for the common PLP shall not exceed 2 Mbits. BUFS shall be transmitted in the second ISSY field of each Interleaving Frame for each PLP. In HEM, BUFS shall also be transmitted for BBFrames for which no UP begins in the Data Field.
- TTO (7/15 bits mantissa + 5 bits exponent). This provides a mechanism to manage the de-jitter buffer in DVB-T2. The value of TTO is transmitted in a mantissa+exponent form and is calculated from the transmitted fields  $TTO\_M$ ,  $TTO\_L$  and  $TTO\_E$  by the formula:  $TTO = (TTO\_M + TTO\_L/256) \times 2^{TTO\_E}$ . If  $ISCR_{short}$  is used,  $TTO\_L$  is not sent and shall equal zero in the above calculation. TTO defines the time, in units of  $T$  (see clause 9.5), between the beginning of the P1 symbol of the first T2-frame to which the Interleaving Frame carrying the relevant User Packet is mapped, and the time at which the MSB of the User Packet should be output, for a receiver implementing the model defined in clause C.1.1. This value may be used to set the receiver buffer status during reception start-up procedure, and to verify normal functioning in steady state. TTO shall be transmitted in the first ISSY field of each Interleaving Frame for each PLP in High Efficiency Mode, and in the first complete packet of the Interleaving Frame in Normal Mode.

- The ISSY code 0xEXXXXX shall not be transmitted in DVB-T2. This range of codes transmitted BUFSTAT in DVB-S2 [i.3], but this parameter is replaced by TTO in DVB-T2.

Each Interleaving Frame for each PLP shall carry a TTO, a BUFS and at least one ISCR field.

NOTE 1: This requires that there are always at least three ISSY fields in every Interleaving Frame. It might be necessary to use short FEC blocks and/or Normal Mode in order to ensure that this is the case. Furthermore, both TTO and ISCR apply to a transmitted User Packet and so it might be necessary to transmit a null packet which would otherwise be deleted to provide a packet for the ISSY field to refer to.

The choice of the parameters of a DVB-T2 system and the use of TTO shall be such that, if a receiver obeys the TTO signalling and implements the model of buffer management defined in clause C.1.1, the receiver's de-jitter buffer and time de-interleaver memory and frequency de-interleaver shall neither overflow nor underflow as defined in clause C.1.2.

NOTE 2: Particular attention should be paid to the frame length, the PLP type, the number of sub-slices per frame, the number of TI-blocks per Interleaving Frame and number of T2-frames to which an Interleaving Frame is mapped, the scheduling of subslices within the frame, the peak bit-rate, and the frequency and duration of FEFs.

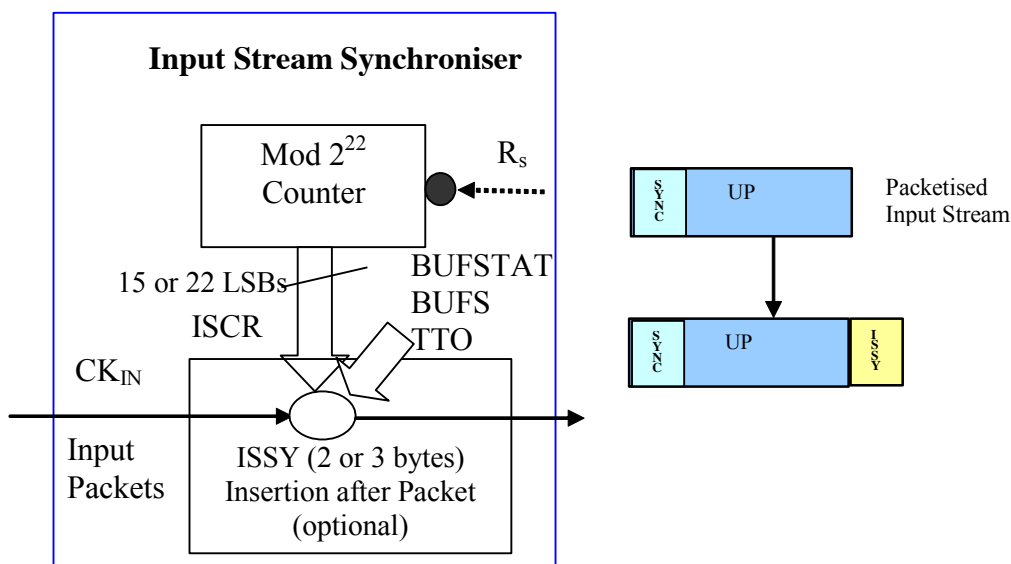


Figure C.1: Input stream synchronizer block diagram

Table C.1: ISSY field coding (2 bytes or 3 bytes)

First Byte					Second Byte	Third Byte
bit-7 (MSB)	bit-6	bit-5 and bit-4	bit-3 and bit-2	bit-1 and bit-0	bit-7 to bit-0	bit-7 bit-0
0 = ISCR <sub>short</sub>	MSB of ISCR <sub>short</sub>	next 6 bits of ISCR <sub>short</sub>			next 8 bits of ISCR <sub>short</sub>	not present
1	0 = ISCR <sub>long</sub>	6 MSBs of ISCR <sub>long</sub>			next 8 bits of ISCR <sub>long</sub>	next 8 bits of ISCR <sub>long</sub>
1	1	00 = BUFS	BUFS unit 00 = bits 01 = Kbits 10 = Mbits 11 = 8Kbits	2 MSBs of BUFS	next 8 bits of BUFS	not present when ISCR <sub>short</sub> is used; else reserved for future use
1	1	01 = TTO	4 MSBs of TTO_E		Bit 7:LSB of TTO_E Bit 6-Bit0: TTO_M	not present when ISCR <sub>short</sub> is used; else TTO_L
1	1	others = reserved for future use	reserved for future use	Reserved for future use	Reserved for future use	not present when ISCR <sub>short</sub> is used; else reserved for future use

## C.1.1 Receiver Buffer Model

When ISSY is used (i.e. ISSYI=1), the following receiver buffer model, illustrated in figure C.2, shall be assumed. This model shall not apply to PLPs that do not use ISSY.

The receiver consists of an RF input, followed by a number of stages of demodulation including the FFT, channel equalization, producing output cells  $\hat{a}_{m,l,p}$  representing estimates of the cells  $a_{m,l,p}$  produced by the frequency interleaver (see clause 8.5). These are fed to the frequency/L1 de-interleaver, which performs both frequency de-interleaving and inversion of the L1-mapping process described in clause 8.3.5, such that its output  $\hat{x}_{m,l,p}$  consists of estimates of the L1 pre-signalling cells, followed by L1 post-signalling cells, followed by the other cells in order of cell address as defined in clause 8.3.6.2.

It shall be assumed that there is a single FEC chain, shared between the data and common PLPs and the L1 decoding, as shown in figure C.2. The FEC chain performs the appropriate subset of the operations of cell de-interleaving, soft demapping, de-puncturing and de-shortening, bit-deinterleaving, LDPC decoding, BCH decoding and BBFrame descrambling.

The equalized cells from the frequency/L1 de-interleaver belonging to the selected data PLP (or its common PLP) are extracted and written into the time de-interleaver (TDI) memory. Cells are later read out of the time de-interleaver and fed to the FEC chain. Equalised cells belonging to the L1 signalling are fed directly to the FEC chain.

The data field bits of decoded BBFrames belonging to a PLP are then converted to a canonical form, independent of the mode adaptation options in use. The canonical form is equivalent to Normal Mode with 3-byte ISSY and NPD enabled (see clause 5.1). The resulting bits are written into a de-jitter buffer (DJB). Bits are read out from the buffer according to a read clock; removed sync bytes and deleted null packets are re-inserted at the output of the de-jitter buffer.

When the receiver is decoding a data PLP together with its associated common PLP, it shall be assumed that the Time De-interleaver and de-jitter buffer are duplicated as shown in figure C.2.

NOTE 1: In this case, although separate time de-interleaving and de-jitter operations are applied to the data PLP and the common PLP, the total memory for the time de-interleaver and the total memory for the de-jitter buffer are shared between the data PLP and the common PLP.

The following assumptions shall be made about the receiver:

- The FEC chain can process cells of a PLP continuously at a rate of  $R_{\text{cell}}$ .  $R_{\text{cell}}$  shall be  $9,5 \times 10^6$  cells/s in the 10 MHz bandwidth and  $7,6 \times 10^6$  cells/s in all other bandwidths.

NOTE 2: The value of  $R_{\text{cell}}$  is reduced for T2-Lite – see annex I.

- The demodulation stages have no delay, and the cells  $\hat{a}_{m,l,p}$  carried in a particular symbol  $l$  are written to the frequency/L1 de-interleaver at a rate of  $R_s$  cells per second starting from the moment symbol  $l$  starts being received. As above,  $R_s = 1/T$ , where  $T$  is defined in clause 9.5.
- The cells  $\hat{x}_{m,l,p}$  carried in a particular data symbol  $l$  are output from the frequency/L1 de-interleaver at a uniform rate and in order of the cell index  $p$  during the time ( $T_s$ ) that the data symbol is being received.
- The cells  $\hat{x}_{m,l,p}$  carried in the P2 symbols are output from the frequency/L1 de-interleaver during the time that the P2 symbols are being received, in the order defined above, and with the following timing:
  - The L1 pre-signalling cells will be fed to the FEC chain at a rate of  $8R_s$  cells per second starting from the moment the first P2 symbol starts to be received.
  - The L1 post-signalling cells will be fed to the FEC chain at a rate of  $R_s$  cells per second starting from the moment the last bit of the L1 pre-signalling has been output from the FEC chain, subject to the following rule:

- The cells of a given L1 post-signalling FEC block will not be fed to the FEC chain but will instead remain in the frequency/L1 de-interleaver until the FEC chain has started to decode the previous FEC block.
- The remaining (i.e. non-L1) data cells of the P2 symbols will be output from the Frequency/L1 de-interleaver at a rate of  $R_S$  cells per second starting from the moment the last bit of the L1 post-signalling has been output from the FEC chain.

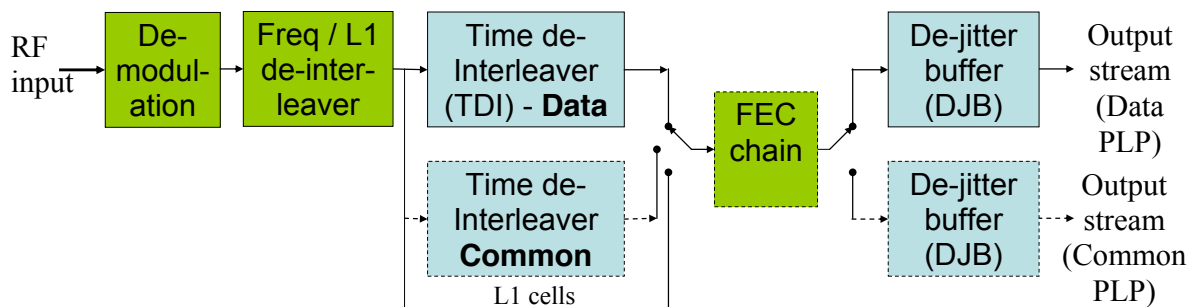
NOTE 3: The overall processing time for the L1 signalling will be limited in some cases by the decoding time for the FEC chain (see below) and in other cases by the rate at which cells can be fed to the FEC chain.

- The FEC chain can decode one FEC block of L1 pre- or post-signalling in a time equal to  $2025/R_{\text{cell}}$  starting from the moment the last cell of the FEC block is fed to the FEC chain.
- The L1-pre and post signalling bits are output from the FEC chain at a rate of  $8R_S$  bits per second starting from the moment the FEC block has been decoded.
- The cells at the output of the frequency/L1 de-interleaver belonging to a particular PLP are written immediately into the TDI memory.
- When time interleaving is used, the TDI will read out the de-interleaved cells of that TI-block, starting as soon as all the cells of a TI-block have been written to the TDI memory, subject to the following:
  - The TDI will read out the cells of a complete FEC block at a rate of  $R_{\text{cell}}$  and feed them to the FEC chain, provided:
    - cells remain from the TI-block being read; and
    - there is at least enough space in the de-jitter buffer to contain the whole of the FEC block being read; and
    - the TDI for the other (i.e. data or common) PLP is not currently feeding cells to the FEC chain; and
    - the FEC chain is not currently decoding the L1 signalling; and
    - reading at the rate of  $R_{\text{cell}}$ , the entire FEC block can be read before the FEC chain will need to begin decoding the L1 signalling.
- When time interleaving is not used, the TDI behaves like a FIFO, and will read out the cells, whenever the occupancy is greater than zero, provided that:
  - there is at least enough space in the de-jitter buffer to contain the whole of the FEC block being read, after conversion to canonical form, assuming that DFL has the maximum possible value ( $K_{\text{bch}}-80$ ); and
  - the FEC chain is not currently decoding the L1 signalling.
- If there is not sufficient space in the de-jitter buffer to contain the whole of the FEC block about to be read, the TDI will wait until there is sufficient space.
- If the common and data PLPs both meet the criteria for reading from the TDI, FEC blocks will be read alternately from the TDIs of the data and common PLP.
- The  $N_{\text{ldpc}}$  error corrected bits of each FEC block are output smoothly from the FEC chain at a rate of  $R_{\text{cell}} * \eta_{\text{MOD}}$ , where  $\eta_{\text{MOD}}$  is the number of bits per cell according to table 11, starting from the instant the first cell of the FEC block is written into the FEC chain.
- The de-jitter buffer will initially discard all input bits until it receives a bit for which a value of TTO is indicated.
- Subsequent input bits will be written to the de-jitter buffer, except that the de-jitter buffer will discard the initial 80 bits of each FEC block (corresponding to the BBHEADER), and all of the bits following the DFL payload bits. In order to allow for the canonical form described above, for every remaining bit that is output from the FEC chain,  $(O\text{-UPL}+24)/\text{UPL}$  bits are stored in the de-jitter buffer (where O-UPL is the original user packet length defined in clause 5.1.1 and UPL is the transmitted user packet length as defined in clause 5.1.8).

- No bits will be output until the time indicated by the value of TTO for the first bit written.
- The bits will then be read and output from the de-jitter buffer at a constant rate calculated from the received ISCR values, using a read clock generated from a recovered clock perfectly synchronized to the modulator's sampling rate clock.
- The size of the de-jitter buffer is 2 Mbits. When a group of data PLPs share a common PLP, the sum of the buffer size for any one data PLP in the group plus the buffer size for the common PLP shall not exceed 2 Mbits.
- The size of the TDI memory is  $2^{19}+2^{15}$  OFDM cells. When a group of data PLPs share a common PLP, the sum of the memory size for time de-interleaving any one data PLP and the memory size for time de-interleaving the common PLP shall not exceed  $2^{19}+2^{15}$  OFDM cells (see clause 6.5.2).

NOTE 4: The size of the TDI memory is  $2^{18}$  OFDM cells for T2-Lite – see annex I.

- Sync bytes will not be stored in the DJB; they will be reinserted at the DJB output.



**Figure C.2: Receiver buffer model**

The following features of a real receiver need not be taken into account by the modulator and should be considered by receiver implementers when interpreting the TTO values and choosing the exact size of the memory to allocate to the de-jitter buffer:

- Additional delays incurred in the various processing stages for practical reasons.
- Error in the regenerated output read-clock frequency and phase.
- Adjustments made to the read-clock frequency and phase in order to track successive ISCR and TTO values. A possible mechanism for doing this is outlined in annex J.
- The limited precision of the TTO signalling.
- The delay of  $N_{p2}$  symbols implicit in the frequency/L1 de-interleaver behaviour described above.

## C.1.2 Requirements of input signal

The signal shall be such that the receiver buffer model of clause C.1.1 behaves as follows:

- Once bits have started to be read and output from the DJB, the occupancy of the receiver's DJB does not fall below one packet.
- The time de-interleaver does not overflow (as defined below).
- The time de-interleaver would not overflow (as defined below) even if the value of BUFS were reduced by three whole FEC blocks. This is to allow margin for receiver implementation and in particular the pipeline delay through the FEC chain.
- The frequency/L1 de-interleaver does not overflow (as defined below).

When time interleaving is used, the time-de-interleaver is considered to overflow if:



- it would need to contain more than  $N_{cells} \times \left\lceil \frac{PLP\_NUM\_BLOCKS\_MAX}{N_{TI}} \right\rceil$  cells; or
- it would need to contain cells from more than two different TI-blocks. (It may contain cells from two consecutive TI-blocks where the cells from one TI-block are being written into the memory and the cells from the previous TI-block are being read out); or
- the  $i$ th cell of a given TI-block would be written to the memory before the  $j$ th cell of the previous TI-block has been read out, where:

$$j = \max \left\{ i, 5N_{\max} \left\lfloor \frac{i}{5N_{wr}} \right\rfloor + i \bmod N_{wr} \right\} - 5(N_{\max} - N_{wr}) - N_{cells}(N_{\max} - N_{rd}) - N_{FIFO}, \text{ where } N_{wr} \text{ and}$$

$N_{rd}$  are the number of FEC blocks in the TI block being written and read respectively, and  $N_{\max}$  is the maximum number of FEC blocks in a TI block, i.e.  $N_{\max} = \left\lceil \frac{PLP\_NUM\_BLOCKS\_MAX}{N_{TI}} \right\rceil$ .

$N_{FIFO}$  represents a small FIFO and shall have the value  $N_{FIFO}=4000$  for modes in which  $NUM\_PLP='1'$ , and shall have the value  $N_{FIFO}=0$  otherwise.

NOTE 1: This formula allows a straightforward implementation of the TDI using a single block of memory and a small FIFO.

NOTE 2: In single PLP modes where ISSY is required, the requirements on the input signal combined with the receiver buffer model mean that the parameters need to be chosen carefully. For example it may be necessary to make  $PLP\_NUM\_BLOCKS$  a multiple of  $N_{TI}$ .

When time interleaving is not used (i.e.  $TIME\_IL\_LENGTH=0$ , see clause 6.5.5), the receiver buffer model shall assume that the time de-interleaver memory is represented by a FIFO and is considered to overflow if the occupancy exceeds one FEC block.

NOTE 3: The use of the receiver buffer model when time interleaving is not used has not been tested at the time of writing. Hence this use may need to be updated in future versions of the present document.

For the purpose of the buffer model described above, the frequency/L1 de-interleaver is assumed to have zero delay, i.e. the first L1 cell is output the moment the first P2 symbols starts to be received.

However, for the purpose of determining overflow in this de-interleaver, it shall be assumed to have a delay of just less than  $N_{p2}$  symbols, such that it starts to output the first L1 cell carried in the P2 symbols the moment the last cell of the last P2 symbol has been written to it.

The frequency/L1 de-interleaver is considered to overflow if:

- In 32K mode, the number of cells that have been written for a given symbol exceeds the number of cells that have been read for the preceding symbol.
- In other modes, cells are written for a given symbol  $l$  before all the cells for symbol  $l-2 \times N_{p2}$  have been read.

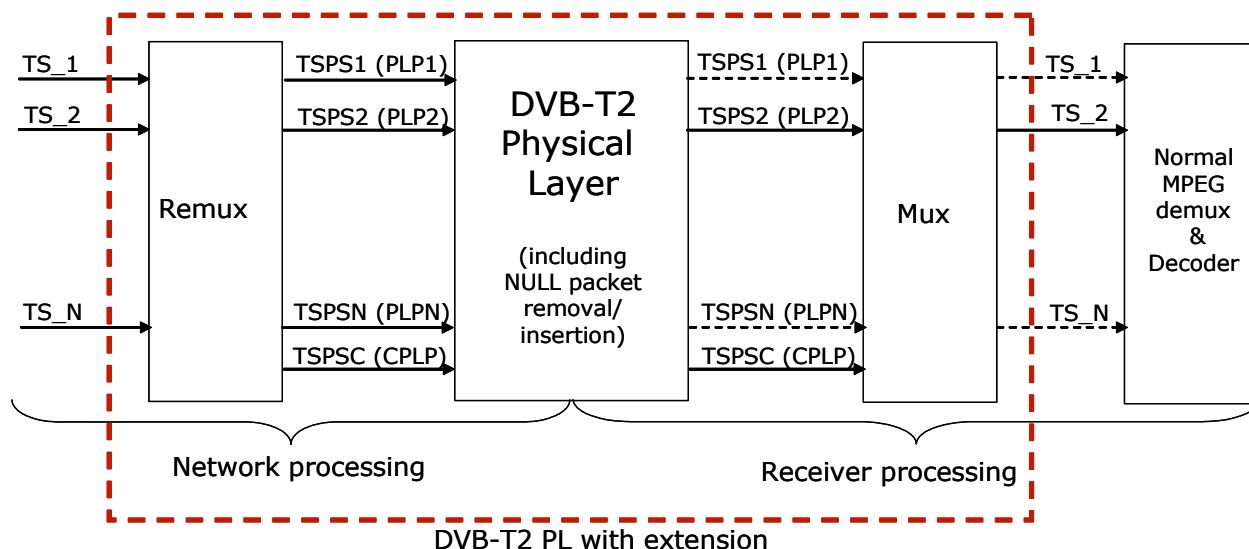
## Annex D (normative): Splitting of input MPEG-2 TSs into the data PLPs and common PLP of a group of PLPs

### D.1 Overview

This annex defines an extension of the DVB-T2 system in the case of MPEG-2 Transport Streams [i.1], which allows the separation of data to be carried in the common PLP for a group of TSs. It includes the processing (remultiplexing) that shall be applied for transporting  $N$  ( $N \geq 2$ ) MPEG-2 TSs (TS\_1 to TS\_N) over  $N$  data PLPs (PLP1 to PLPN) and the common PLP (CPLP) of a group of PLPs, see figure D.1.

If this processing is not applied to a group of Transport Streams, there shall be no common PLP for this group, and each PLP of the group shall carry the input TS without modification. When several groups of PLPs are used to carry TSs, each such group has its own independent extension functionality.

This annex also describes the processing that can be carried out by the receiver to reconstruct a single input TS from the received data PLP and its corresponding common PLP.



**Figure D.1: Multiple TS input/output to/from the extended DVB-T2 PL**

The extension consists on the network side conceptually of a remultiplexer and on the receiver side of a multiplexer. In-between the remultiplexer and the multiplexer we have the DVB-T2 system, as described in other parts of the present document. The inputs/outputs to the DVB-T2 system are syntactically correct TSs, each with unique `transport_stream_ids`, containing all relevant layer 2 (L2) signalling information (i.e. PSI/SI - see [i.1] and [i.4]). The various input TSs may have PSI/SI tables, or other L2 data, in common with other input TSs. When the extension is used the generated TSPS (Transport Stream Partial Stream) and TSPSC (Transport Stream Partial Stream Common) streams are however typically not syntactically correct MPEG-2 TSs.

**NOTE:** The parallel TSs may only exist internally in equipment generating the DVB-T2 signal. The parallel TSs may e.g. be generated from a single high bit rate TS source, or may alternatively be generated by centrally-controlled parallel encoders, each producing a constant bit rate TS, with variable proportion of null packets. The bit rates of the input TSs may be significantly higher than the capacity of the respective PLPs, because of the existence of a certain proportion of null packets, which are removed by the DNP procedure.

An input MPEG-2 TS shall be transported either:

- in its entirety within a single PLP, in which case the TS does not belong to any group of PLPs (and there is no common PLP); or
- split into a TSPS stream, carried in a data PLP, and a TSPSC stream, carried in the common PLP. This annex specifies the splitting and describes how the recombination of the output streams from a data PLP and the common PLP can conceptually be achieved by the receiver to form the output TS.

## D.2 Splitting of input TS into a TSPS stream and a TSPSC stream

### D.2.1 General

When a set of  $N$  TSs ( $TS_1, \dots, TS_N, N \geq 2$ ) are sent through a group of  $N+1$  PLPs, one being the common PLP of a group, all TSs shall have the same input bit rate, including null packets. All input TS streams shall also be packet-wise time synchronized. All TSPSs and the TSPSC shall have the same bit rate as the input TSs and maintain the same time synchronization. For the purpose of describing the split operation this is assumed to be instantaneous so that TSPSs and the TSPSC are still co-timed with input TSs after the split.

NOTE: The input TSs may contain a certain proportion of null packets. The split operation will introduce further null packets into the TSPSs and the TSPSC. Null packets will however be removed in the modulator and reinserted in the demodulator in a transparent way, so that the DVB-T2 system will be transparent for the TSPSs and the TSPSC, despite null packets not being transmitted. Furthermore, the DNP and ISSY mechanism of the DVB-T2 system will ensure that time synchronization of the TSPSs and the TSPSC at the output of the demodulator is maintained.

When reference is made to TS packets carrying SDT or EIT in the current annex the intended meaning is *TS packets carrying sections carrying SDT or EIT*, i.e. the data being carried within the TS packet is not limited to the SDT or EIT itself but includes the full section (i.e. with CRC).

For the purpose of specifying the split operation the TS packets that shall be transmitted in the common PLP fall into the following three categories:

- 1) TS packets that are co-timed and identical on all input TSs of the group before the split.
- 2) TS packets carrying Service Description Table (SDT) and not having the characteristics of category (1).
- 3) TS packets carrying Event Information Table (EIT) and not having the characteristics of category (1).

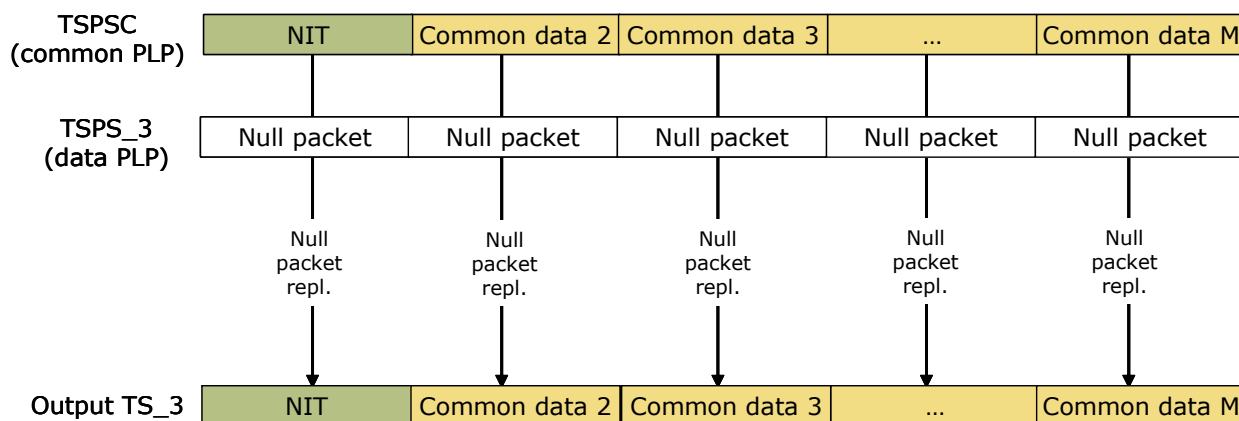
For reference to SDT and EIT, see [i.4].

Figures D.2 to D.6 are simplified insofar as they do not show any data packets or null packets in the input TSs. In real input TSs these are of course to be expected. Similarly, a section is not necessarily wholly contained in a TS packet, but may be segmented over several TS packets and may also share capacity of a TS packet with other sections of the same or other types using the same PID value. These simplifications do not in any way affect the general applicability of the splitting/re-combining process, as described in this annex.

## D.2.2 TS packets that are co-timed and identical on all input TSs of the group before the split

TS packets that are co-timed and identical on all input TSs of the group before the split shall, after the split, appear at the same time positions in the TSPSC and, if so, shall be replaced by null packets in the respective TSPSs at the same time positions.

The receiver can recreate the input TS when any packets other than null packets appear in the TSPSC, by replacing null packets in the currently received TSPS with the corresponding TS packets in the TSPSC at the same time positions, see figure D.2.



**Figure D.2: Example of recombination of input TS from TSPS and TSPSC for category 1**

## D.2.3 TS packets carrying Service Description Table (SDT) and not having the characteristics of category (1)

Sections with table\_id=0x42 (HEX) are referred to as SDT actual TS.

Sections with table\_id=0x46 (HEX) are referred to as SDT other TS.

TS packets with PID=0x0011 and table\_id of all carried sections equal to 0x46 (HEX), shall be carried in the TSPSC provided the following conditions are fulfilled:

- 1) At a given time position there is in one input TS a TS packet which is not a null packet.
- 2) In all the other input TSs of the group there are, at this time position, mutually identical TS packets, not equal to that in condition (1), with PID=0x0011, with the section header table\_id field of all carried section headers equal to 0x46 and with the value of the transport\_stream\_id field in all carried sections equal to the transport\_stream\_id of the TS in condition (1).
- 3) Sections with table\_id 0x42 and 0x46 are never partly or fully carried in the same TS packet with PID=0x0011.

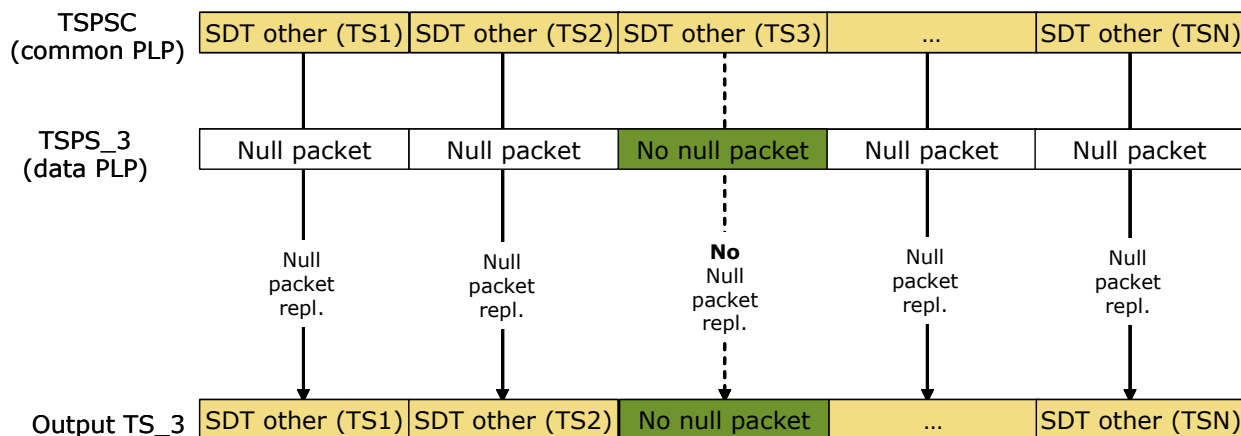
If these conditions are met, the input TS packets carrying the SDT actual shall not be modified, but copied directly to the corresponding TSPS at the same time position. The input TS packets carrying SDT other shall be replaced by null packets in the corresponding TSPS, and the TS packets carrying SDT other shall be carried in the TSPSC, as shown in figure D.3.

NOTE: TS packets carrying SDT sections (partly or fully) may also carry other section types using the same PID, such as BAT and ST, see [i.4].

**Figure D.3: Arrangement of SDT other in input TSs and relationship with TSPSC**

As a result of the split all TS packets carrying SDT actual are therefore left unmodified in the respective TSPS at the same time position as in the input TS, whereas all TS packets carrying SDT other are found in the TSPSC at the same time position as in the input TS.

The receiver can recreate the input TS when SDT other packets appear in the TSPSC, by replacing null packets in the currently received TSPS with the corresponding SDT other packets from the TSPSC at the same time positions. When there is not a co-timed null packet in the TSPS, the receiver shall not modify the TSPS to achieve full transparency. This is shown in figure D.4.



**Figure D.4: Receiver operation to re-combine of TSPS and TSPSC into output TS for SDT**

## D.2.4 TS packets carrying Event Information Table (EIT) and not having the characteristics of category (1)

- Sections with table\_id=0x4E (HEX) are referred to as EIT actual TS, present/following.
- Sections with table\_id=0x4F (HEX) are referred to as EIT other TS, present/following.
- Sections with table\_id=0x50 to 0x5F (HEX) are referred to as EIT actual TS, schedule.
- Sections with table\_id=0x60 to 0x6F (HEX) are referred to as EIT other TS, schedule.

The operations described in clause D.2.4.1 shall be performed when the conditions described in clause D.2.4.2 are fulfilled.

### D.2.4.1 Required operations

At a particular time position a TS packet carrying EIT other (PID=0x0012) shall be copied into the same time position in the TSPSC and the input TS packets of all TSPSs of the group at the same time position shall be replaced by null packets.

### D.2.4.2 Conditions

In all input TSs of the group except one there shall, at this time position, be identical TS packets carrying EIT other, with value of the section header transport\_stream\_id field equal to the transport\_stream\_id of the remaining input TS. At the same time position there shall be, in the remaining input TS, a TS packet carrying EIT actual, with the value of the section header transport\_stream\_id field equal to the transport\_stream\_id of the same input TS. At this time position, the TS packet carrying EIT actual shall be identical to those carrying EIT other, except for the table\_id, last\_table\_id and CRC of the carried section. The table\_ids and last\_table\_ids of co-timed TS packets carrying EIT actual and EIT other shall have the 1-to-1 mapping given in table D.1. The required operations at a particular time position, given in clause D.2.4.1, shall only be performed if the TS packets carrying other parts, if any, of the same section(s) are also subject to the same required operation, i.e. an EIT section shall either be completely transported in the common PLP or in a data PLP.

Table D.1: Correspondence between table\_ids of co-timed EIT actual and EIT other in input TSs

table_id or last_table_id of EIT actual in input TS	table_id or last_table_id of co-timed EIT other in input TS
0x4E	0x4F
0x50	0x60
0x51	0x61
0x52	0x62
0x53	0x63
0x54	0x64
0x55	0x65
0x56	0x66
0x57	0x67
0x58	0x68
0x59	0x69
0x5A	0x6A
0x5B	0x6B
0x5C	0x6C
0x5D	0x6D
0x5E	0x6E
0x5F	0x6F

This means that at a particular time position with TS packets carrying EIT all these TSs carry identical TS packets with the exception of section table\_id in one TS being set to "actual" rather than "other" and the CRC of the corresponding sections being different for EIT actual and other, see table D.1 and figure D.5.

NOTE 1: TS packets carrying EIT sections (partly or fully) may also carry other section types using the same PID, such as ST and CIT, see [i.4].

Figure D.5: Example of arrangement of EIT actual/other in input TSs and relationship with TSPSC

As a result of the split all TS packets carrying EIT actual and EIT other are replaced by null packets in the respective TSPS at the same time position. All TS packets carrying a section or sections with EIT other in the input TSs are copied to the TSPSC at the same time position as in the input TS.

The receiver can recreate the input TS when EIT other packets appear in the TSPSC, by replacing null packets in the currently received TSPS with the corresponding EIT other packets from the TSPSC at the same time positions. For TS packets carrying EIT other, with the value of the section header transport\_stream\_id field equal to the transport\_stream\_id of the currently decoded TS, the receiver should also modify the table\_id and last\_table\_id from "other" to "actual" and modify the CRC, so that it is calculated from the "actual" table\_id and last\_table\_id rather than the "other" table\_id and "other" last\_table\_id, to achieve full TS transparency, see table D.1 and figure D.6.

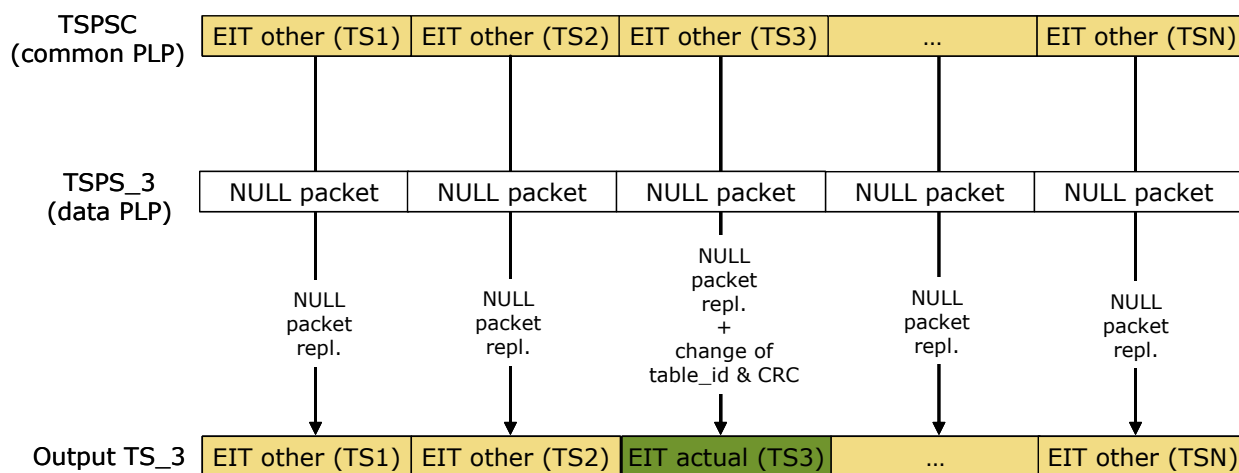


Figure D.6: Receiver operation to re-combine of TSPS and TSPSC into output TS for EIT

NOTE 2: For TS packets carrying *scrambled EIT schedule* it may be difficult to perform the above-mentioned modification of `table_id` and `last_table_id` from "other" to "actual" and change of CRC. Therefore, in such cases the output TS may contain only EIT other. The information of the EIT actual of the input TS, referring to the currently decoded TS, is however available in the EIT other, referring to the same TS.

---

## D.3 Receiver Implementation Considerations

In view of the key role played by the transport stream as a physical interface in many existing and future receivers it is strongly recommended that at least the core of the merging function as described in this annex is implemented in a channel decoder silicon. In particular this applies to the generic merging function between TSPSC and TSPS to form a transport stream:

- for category-1 (generic data) as defined in clause D.2.2 illustrated in figure D.2;
- for category-2 (SDT) as defined in clause D.2.3 and illustrated in figure D.4; and
- for category-3 (EIT) as defined in clause D.2.4 and illustrated in figure D.6.

It may be possible that the change of `table_id` and CRC, as defined for category-3 data (to reconstruct `EIT_actual` from `EIT_other`) could be handled by software on an MPEG system processor (which avoids that channel decoders would have to implement section level processing).

The channel decoder implementations as defined above should ensure correct integration of many existing DVB system hardware and software solutions for DVB with such channel decoders.

## Annex E (informative): T2-frame structure for Time-Frequency Slicing

### E.1 General

Time-Frequency-Slicing (TFS) is a method where the sub-slices of a PLP are sent over multiple RF frequencies during the T2-frame. Interleaving is thus applied both over time and frequency.

Although the present document describes a single profile which does not include TFS, this annex describes those features which would allow a future implementation of TFS, assuming that a receiver has two tuners/front-ends. Receivers with one tuner are not expected to be TFS compatible. It is not required that receivers implement the contents of this annex.

The present document includes all elements needed to support the use of TFS. In addition to what is required for single RF-frequency emission, this includes mainly signalling and associated frame structure for Time-Frequency slicing. Thus a full TFS system can be built based on the normative parts of the present document. To fully support TFS, it is expected that a receiver will have to have two tuners to receive a single service. This annex gives the formal rules for building the T2-frame when TFS is used.

The basic block diagrams given in figure 2 broadly apply when TFS is used, but the frame builder and OFDM generation modules are modified to include additional chains so that there is one branch for each of the  $N_{RF}$  RF channels of the TFS system, as shown in figure E.1.

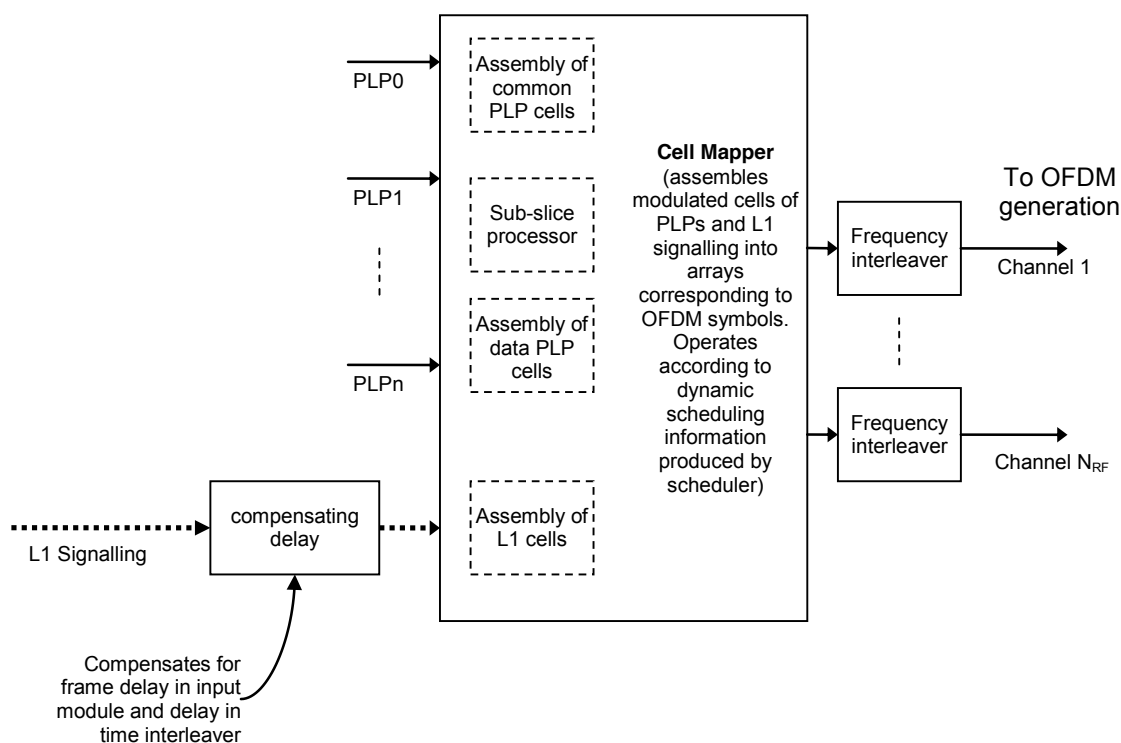
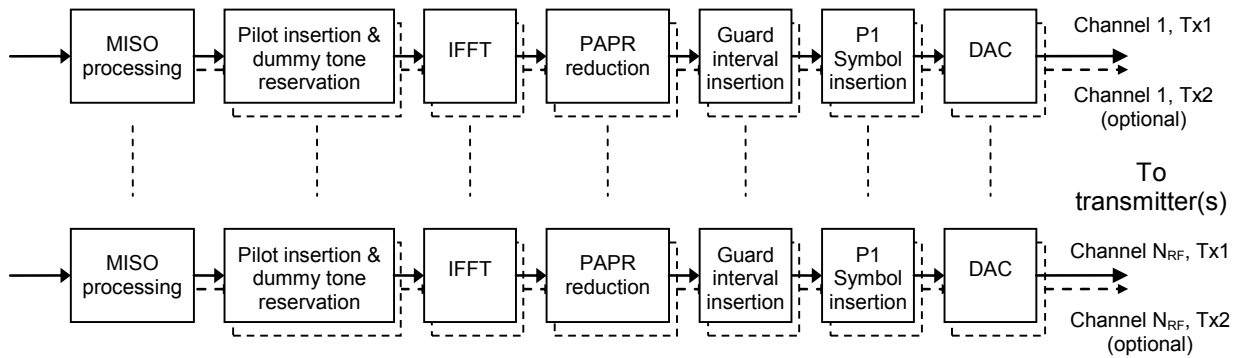


Figure E.1(a): Frame builder for TFS





**Figure E.1(b): OFDM generation for TFS**

NOTE: The maximum bit rates mentioned in clause 4.1 also apply in the case of TFS.

## E.2 T2-frame structure

### E.2.1 Duration and capacity of the T2-frame

The duration of the T2-frame using Time-Frequency slicing (TFS) is calculated with the same formula as with one RF channel:

$$T_F = (N_{P2} + L_{data}) \times T_s + T_{P1},$$

where  $N_{P2}$  is the number of P2 symbols on one RF channel and  $L_{data}$  is the number of data symbols on one RF channel. The rules for the frame length defined in clause 8.3.1 apply. Also, the number of P2 symbols  $N_{P2}$  is calculated as defined in table 51.

The number of active OFDM carriers in one T2-frame for all RF channels is given by:

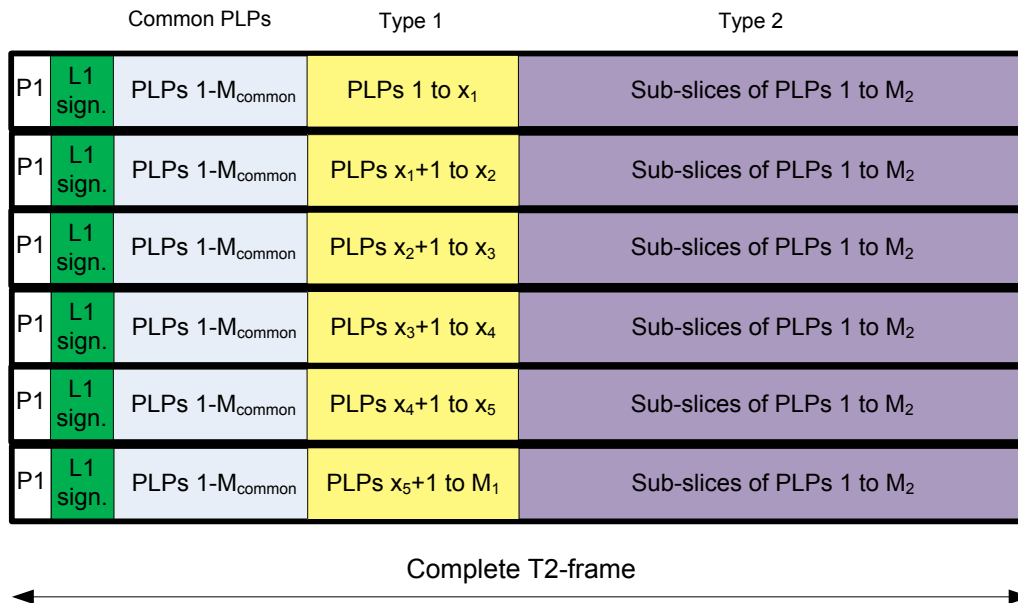
$$C_{tot} = \begin{cases} (N_{P2} \times C_{P2} + (L_{data} - 1) \times C_{data} + C_{LS}) \times N_{RF} & \text{when there is a frame closing symbol} \\ (N_{P2} \times C_{P2} + L_{data} \times C_{data}) \times N_{RF} & \text{otherwise} \end{cases}$$

### E.2.2 Overall structure of the T2-frame

When using TFS the T2-frame has a similar structure as with one RF channel, except that the sub-slices of type 2 data PLPs are distributed over all RF channels during one T2-frame. P1 symbols, L1 signalling and common PLPs are repeated simultaneously on each RF channel, as these should always be available while receiving any type 2 data PLP. Each type 1 data PLP only occurs on one RF channel in one T2-frame but different type 1 data PLPs are transmitted on different RF channels. The RF channel for a type 1 PLP may change from frame to frame (inter-frame TFS) or may be the same in every frame (Fixed Frequency) according to the L1 configurable signalling parameter FF\_FLAG. The structure of the T2-frame with TFS is depicted in figure E.2.

The number of OFDM cells needed to carry all common PLPs in one T2-frame on one RF channel is denoted by  $D_{common}$ . The number of OFDM cells needed to carry all L1 signalling in one T2-frame on one RF channel is denoted by  $D_{L1}$ . The number of OFDM cells available for transmission of data PLPs in one T2-frame for all RF channels is given by:

$$D_{data} = C_{tot} - D_{common} \times N_{RF} - D_{L1} \times N_{RF}.$$



**Figure E.2: Structure of the T2-frame in a TFS system**

In a TFS system a T2-frame will start at the same point in time on all RF channels, i.e. in all transmitters. This means that the P1 symbols occur at the same point in time on all RF channels, followed by the P2 symbol(s) and data symbols.

The L1-pre and L1-post signalling will be generated, coded and mapped to each channel individually as for the single RF case. The L1-pre signalling will be different on each channel because the CURRENT\_RF\_IDX and consequently the CRC-32 will both be different. The L1-post signalling will be identical on each RF channel.

The addressing scheme for the data cells will be applied to each RF channel individually exactly as for the single RF case.

### E.2.3 Structure of the Type-2 part of the T2-frame

The type 2 data PLPs will be carried in a total of  $N_{\text{sublices\_total}}$  sub-slices across all RF channels;  $N_{\text{sublices\_total}}$  is signalled by the configurable L1 signalling parameter NUM\_SUB\_SLICES. The structure of the TF-sliced part (type 2 data PLPs) of a T2-frame is depicted in figure E.3.

The sub-slices of type 2 data PLPs are shifted in relation to each other on the different RF channels to enable jumping between the RF channels during a T2-frame.

If a sub-slice is divided on one RF channel, as in the case of PLP2 on RF3 and PLP4 on RF2, this is still considered to be the same sub-slice for the definition of  $N_{\text{sublices\_total}}$ . For example,  $N_{\text{sublices\_total}} = 6$  in figure E.3.

The beginning of the area for type 2 PLPs will be the same OFDM cell address, denoted by  $A_2$ , on each RF channel.

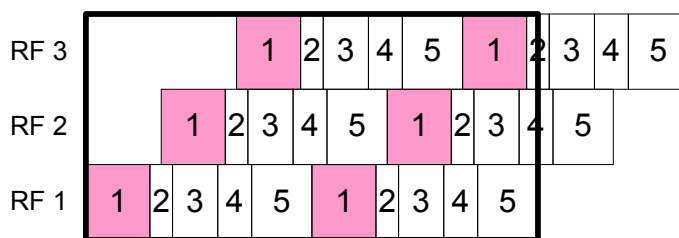


Figure E.3(a): The structure of the type 2 part of a T2-frame with  $N_{RF} = 3$  and  $N_{subsllices\_total} = 6$  before folding, showing the sub-slices exceeding the frame

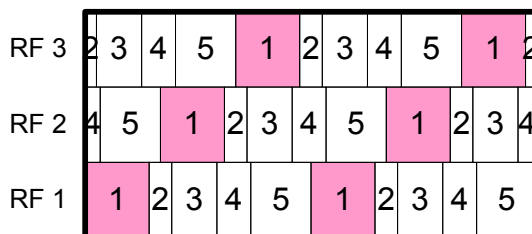


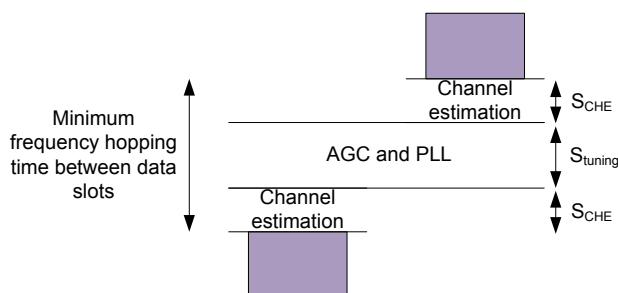
Figure E.3(b): The structure of the type 2 part after folding of the sub-slices

## E.2.4 Restrictions on frame structure to allow tuner switching time

When using Time-Frequency Slicing (TFS) there are more restrictions to frame length to enable enough time for switching between the RF channels. The restrictions apply when the number of RF channels ( $N_{RF}$ ) is greater than the number of tuners in the receiver. In practical applications the number of tuners is two. When using two tuners in the receiver, TFS with two RF channels does not require additional limitations to the one RF configuration, as it is not necessary to perform frequency hopping.

When  $N_{RF} > 2$  the following restrictions for the T2-frame structure apply:

- The time between two sub-slices to be received with the same tuner should be guaranteed, both between sub-slices and at the frame edge.
- The minimum frequency hopping time between sub-slices on different RF channels for a tuner is  $2 * S_{CHE} + \lceil S_{tuning} \rceil$ , where  $S_{CHE}$  is the number of symbols needed for channel estimation and  $\lceil S_{tuning} \rceil$  is the number of symbols needed for tuning rounded up to the nearest integer (figure E.4).
- The minimum tuning time is 5 ms, so that  $S_{tuning} * T_S \geq 5ms$ . The values for  $\lceil S_{tuning} \rceil$  are presented in table E.1.
- The value for  $S_{CHE}$  is dependent on the used pilot pattern.  $S_{CHE} = D_Y - 1$ , where  $D_Y$  is the number of symbols forming one scattered pilot sequence defined in table 57.



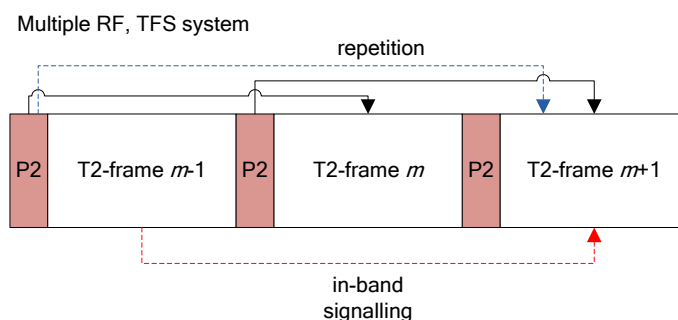
**Figure E.4: Minimum required frequency hopping time between two sub-slices to be received with the same tuner**

**Table E.1: Values for  $\lceil S_{tuning} \rceil$  (number of symbols needed for tuning, rounded up, for 8 MHz bandwidth), when minimum tuning time = 5 ms**

FFT size	$T_u$ [ms]	Guard interval						
		1/128	1/32	1/16	19/256	1/8	19/128	1/4
32K	3,584	2	2	2	2	2	2	NA
16K	1,792	3	3	3	3	3	3	3
8K	0,896	6	6	6	6	5	5	5
4K	0,448	NA	11	11	NA	10	NA	9
2K	0,224	NA	22	22	NA	20	NA	18
1K	0,112	NA	NA	10	NA	9	NA	8

## E.2.5 Signalling of the dynamic parameters in a TFS configuration

In a TFS system the L1-post dynamic signalling transmitted in P2 will refer to the next T2-frame and the in-band signalling for the current PLP will refer to the next-but-one Interleaving Frame, as depicted in figure E.5 and described in detail in clauses 7.2.3 and 5.2.3 respectively.



**Figure E.5: L1 signalling for a TFS system**

## E.2.6 Indexing of RF channels

Each RF channel in a T2 system is allocated an index between 0 and  $NUM\_RF-1$ .

The indexing of the RF channels is signalled in the `CURRENT_RF_IDX` parameter in the L1-pre signalling (for the current frequency) and the `RF_IDX` parameter in the configurable part of the L1-post signalling (in the loop for all  $N_{RF}$  channels) as described in clauses 7.2.2 and 7.2.3.1 respectively. In TFS mode, the index indicates the order of each frequency within the TFS configuration. The 'next' RF channel will be the one whose index is one greater than the current channel; the 'next' channel after the RF channel whose index is  $NUM\_RF - 1$  will be the RF channel with  $RF\_IDX = 0$ .

The RF indexing scheme is used for the configurable and PLP-specific parameter `FIRST_RF_IDX` for the type 1 data PLPs. This parameter indicates on which RF channel the PLP occurs in the first T2-frame of the super-frame to which that PLP is mapped; see clause E.2.7.1.

The indexing of the RF channels is also used in the signalling for the type 2 PLPs. The RF channel whose index is equal to the dynamic L1 parameter `START_RF_IDX` is designated as  $RF_{start}$ , and is the RF channel on which the first subslice for each PLP starts at the address given by the `PLP_START` parameter. The subslices on the RF channel with the next index are shifted by  $1 \times RF\_SHIFT$ , the next by  $2 \times RF\_SHIFT$ , etc. as described in clause E.2.7.2.3.

## E.2.7 Mapping the PLPs

The allocation of sub-slices to the T2-frame is done by the scheduler as in the single-RF case. The scheduler may use any method to perform the allocation and may map the PLPs to the T2-frame in any order, provided:

- that the locations of the cells of the PLPs are as described by the L1 signalling, interpreted as described in the following clauses; and also
- that the requirements for tuner switching time described in clause E.2.4 are met.

### E.2.7.1 Mapping the Common and Type 1 PLPs

For the common and type 1 PLPs, the address range of the cells for each PLP in a given T2-frame will be signalled exactly as for the single RF case.

Each of the cells of a common PLP will be carried on all of the RF channels and will be mapped to the same cell address in each channel.

Each of the Type 1 PLPs will be mapped to only one RF channel in a given T2-frame.

For Type 1 PLPs which are Fixed Frequency (`FF_FLAG='1'`), the RF channel to which the PLP is mapped will be signalled directly by the L1 signalling parameter `FIRST_RF_IDX`.

For Type 1 PLPs which are not Fixed-Frequency (`FF_FLAG='0'`), the index of the RF channel on which each Type 1 PLP appears in a given frame is denoted by `PLP_channel` and can be determined by:

$$PLP\_channel = \left( \frac{FRAME\_IDX - FIRST\_FRAME\_IDX}{FRAME\_INTERVAL} + FIRST\_RF\_IDX \right) \bmod N_{RF},$$

where `FRAME_IDX`, `FIRST_FRAME_IDX`, `FRAME_INTERVAL` and `FIRST_RF_IDX` are the corresponding L1-signalling parameters.

### E.2.7.2 Mapping the Type 2 PLPs

Type 2 data PLPs will be mapped starting from the cell address immediately following the last address allocated to Type 1 PLPs. The Type 2 PLPs start from the same active cell address in every RF. The Type 1 PLPs should therefore be allocated such that they all end at the same address in every RF.

#### E.2.7.2.1 Allocating the cells of the Interleaving Frame to the T2-Frames

The scheduler allocates an integer number of LDPC blocks  $N_{BLOCKS\_IF}(i,n)$  to each Interleaving Frame  $n$ , for each PLP  $i$ . The number of LDPC blocks allocated is used to inform the frame builder of the size of the sub-slices required within each T2-frame.

The slice size  $D_{i,2}$ , i.e. the number of OFDM cells required for Type-2 PLP  $i$  in each T2-frame to which the Interleaving Frame is mapped, is calculated as:

$$D_{i,2} = \frac{N_{BLOCKS\_IF}(i,n) \times N_{LDPC}(i)}{P_I(i) \times \eta_{MOD}(i)},$$

where  $N_{\text{BLOCKS\_IF}}(i,n)$  is the number of LDPC blocks  $N_{\text{BLOCKS\_IF}}(n)$  in the current Interleaving Frame (index  $n$ ) for PLP  $i$ ;  $N_{\text{ldpc}}(i)$  is the LDPC block length and  $\eta_{\text{MOD}}(i)$  is the number of bits per cell for PLP  $i$ .  $P_1(i)$  is the number of T2-frames to which the Interleaving Frame is mapped, and  $N_{\text{BLOCKS\_IF}}(n)$  was defined in clause 6.5 for the Time Interleaver.

As for the single RF case, the value of  $P_1$  will be chosen such that  $D_i$  is an integer for all PLPs, and also that  $P_1$  and  $N_{\text{subslices\_total}}$  meet the additional constraints given in clause E.2.7.2.2.

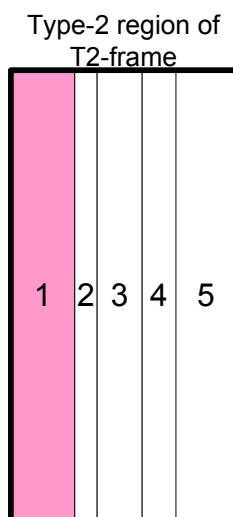
**EXAMPLE:** Figure E.6 depicts the OFDM cells for data PLPs of a T2-frame. In this example, there are five type 2 data PLPs carried in the frame.

The restrictions for capacity allocation for type 2 data PLPs are dependent on  $D_{\text{data}}$  (the total number of data cells available in the T2-frame), the number of data cells used by type 1 data PLPs, the number of data PLPs carried in the T2-frame, and the number of sub-slices  $N_{\text{subslices\_total}}$ .

The sum of all cells of all type 1 and type 2 data PLPs cannot exceed the number of cells reserved for data PLPs:

$$\sum_{i=1}^{M_1} D_{i,1} + \sum_{i=1}^{M_2} D_{i,2} \leq D_{\text{data}}$$

where  $D_{i,1}$  is the size of type 1 data PLP  $i$  in OFDM cells.



**Figure E.6: Capacity allocation of five type 2 data PLPs to one T2-frame**

### E.2.7.2.2 Size of the sub-slices

The size of each sub-slice is given by  $D_{i,2} / N_{\text{subslices\_total}}$ , where  $D_{i,2}$  is the total number of data cells mapped to the current T2-frame for type 2 data PLP  $i$ .  $N_{\text{subslices\_total}}$  is the same for all type 2 data PLPs and it is given by:

$$N_{\text{subslices\_total}} = N_{\text{RF}} N_{\text{subslices}}$$

where  $N_{\text{RF}}$  is the number of RF channels and  $N_{\text{subslices}}$  is the number of sub-slices per RF channel. Figure E.3 shows an example of sub-slicing for  $N_{\text{RF}} = 3$  and  $N_{\text{subslices}} = 2$ .

**NOTE 1:** Because sub-slices can be divided between the beginning and end of the frame as a result of the cyclic rotation, the allocation of data cells to the sub-slices is not as straightforward as in the single-RF case and occurs as a result of the mapping described in clause E.2.7.2.5.

The value of  $N_{\text{subslices\_total}}$  should be chosen such that:

$$(N_{\text{cells}}) \bmod (5 P_1(i) \times N_{\text{subslices\_total}}) = 0, \text{ for all } i.$$

Suitable values for  $N_{\text{subslices\_total}}$  are listed in annex L for the case where  $P_1=1$ . The value of  $N_{\text{subslices\_total}}$  is signalled in L1-post signalling field SUB\_SLICES\_PER\_FRAME.

NOTE 2: The number of OFDM cells for each PLP,  $D_{i,2}$ , may be different but every  $D_{i,2}$  will be a multiple of  $N_{\text{subslices\_total}}$ , so that all sub-slices carrying the same PLP have equal size. This is guaranteed provided the above requirement, which is more restrictive, is met.

The cell addresses to which each Type 2 PLP is mapped should be determined as follows.

### E.2.7.2.3 Allocation of cell addresses to the sub-slices on $\text{RF}_{\text{start}}$

The dynamic L1 signalling parameter PLP\_START indicates the address of the first cell of the first sub-slice in  $\text{RF}_{\text{start}}$ .  $\text{RF}_{\text{start}}$  is the RF channel whose index CURRENT\_RF\_IDX is equal to the dynamic L1 signalling parameter START\_RF\_IDX, and is the channel on which the sub-slices are not shifted or folded. The RF channel that is referred to as  $\text{RF}_{\text{start}}$  may change between T2-frames. The locations of the other sub-slices of each PLP are calculated in the receiver based on the first sub-slice of  $\text{RF}_{\text{start}}$ . If there is more than one sub-slice per RF channel per T2-frame, then the addresses of the first cells of the successive sub-slices on  $\text{RF}_{\text{start}}$  should be spaced by SUB\_SLICE\_INTERVAL as for the single RF case. The cells of each sub-slice of each PLP will be mapped one after the other into the T2-frame on  $\text{RF}_{\text{start}}$  as described in clause 8.3.6.3.3 for the single RF case.

NOTE: With the mapping described, SUB\_SLICE\_INTERVAL will be equal to  $\frac{D_{\text{Type2}}}{N_{\text{subslices\_total}}}$ , where:

$$D_{\text{Type2}} = \sum_{i=1}^{M_2} D_{i,2} \text{ is the number of OFDM cells on all RF channels carrying type 2 PLPs; and}$$

$$N_{\text{subslices\_total}} \text{ is the number of sub-slices per T2-frame across all RF channels.}$$

A receiver cannot assume that SUB\_SLICE\_INTERVAL can be calculated as described in the note above, but instead should use the signalled value (see clause 7.2.3.2).

The address of the first and last cell for the sub-slice  $j$  on  $\text{RF}_{\text{start}}$  of a type 2 data PLP are therefore given by:

$$\text{Sub\_slice\_start}(j) = \text{PLP\_START} + j \times \text{SUB\_SLICE\_INTERVAL}$$

$$\text{Sub\_slice\_end}(j) = \text{Sub\_slice\_start}(j) + \frac{\text{PLP\_NUM\_BLOCKS} \times N_{\text{cells}}}{N_{\text{subslices\_total}} \times P_1} - 1.$$

for  $j=0, 1, \dots, N_{\text{subslices\_total}}-1$ . Here  $N_{\text{subslices\_total}} = \text{SUB\_SLICES\_PER\_FRAME}$  and  $N_{\text{cells}}$  is the number of OFDM cells in an LDPC block as given in table 17 and  $P_1$  is the number of T2-frames to which an Interleaving Frame is mapped. PLP\_START, SUB\_SLICE\_INTERVAL, and PLP\_NUM\_BLOCKS are the L1 signalling parameters defined in clause 7.2.3.2. The sub-slice allocation consists of all of the cells in this range.

### E.2.7.2.4 Allocation of cell addresses to the sub-slices on the other RF channels

The sub-slice allocations on each of the other RF channels are shifted by  $\text{RF\_shift}$  cells with respect to the corresponding allocations on the previous RF channel. The shift is performed cyclically, i.e. addresses exceeding the range of  $(D_{\text{type2}}/N_{\text{RF}})$  addresses allocated to the Type 2 PLPs will be "folded back" to the beginning of the Type 2 region.

$\text{RF\_shift}$  is not signalled directly but can be determined by:

$$\text{RF\_shift} = \frac{\text{SUB\_SLICE\_INTERVAL}}{N_{\text{RF}}},$$

where SUB\_SLICE\_INTERVAL is the L1-signalling parameter.

Therefore, for each address  $A_0$  allocated to a particular PLP on RF<sub>start</sub>, the corresponding address  $A_n$  should be allocated to the same PLP on the RF channel whose index is  $[(\text{START\_RF\_IDX}+n) \bmod N_{\text{RF}}]$ , for each  $n, 0 < n < N_{\text{RF}}$ , where:

$$A_n = A_{\text{START2}} + [(A_0 - A_{\text{START2}} + n \times \text{RF\_shift}) \bmod D_{\text{type2}} / N_{\text{RF}}],$$

and  $A_{\text{START2}}$  is the address of the start of the Type 2 region.

The value of  $D_{\text{type2}}$  itself is equal to  $\text{NUM\_RF} \times \text{SUB\_SLICE\_INTERVAL}$ . The value of  $A_{\text{START2}}$  is signalled by the dynamic L1 signalling parameter TYPE\_2\_START.

Figure E.7 illustrates the sub-slice locations before the folding has been applied and figure E.8 illustrates the allocations after the folding. For simplicity, START\_RF\_IDX=0 in the figure so that RF 0 is RF<sub>start</sub>.

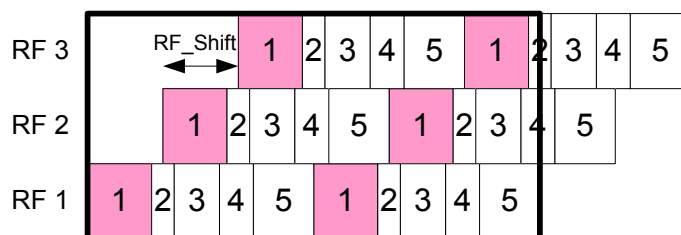


Figure E.7: Cell allocations for the sub-slices prior to "folding"

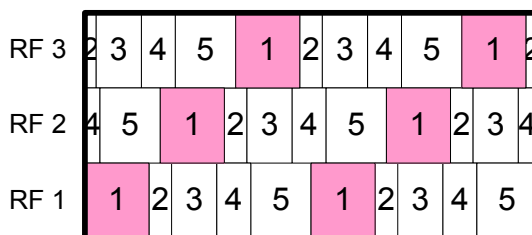


Figure E.8: Cell allocations for the sub-slices after folding

NOTE 1: For the mapping described, RF\_shift will be given by:

$$\text{RF\_shift} = \frac{D_{\text{Type2}}}{N_{\text{RF}}^2 N_{\text{subslices}}} = \frac{D_{\text{Type2}}}{N_{\text{RF}} N_{\text{subslices\_total}}},$$

where  $N_{\text{RF}}$  is the number of RF channels,  $N_{\text{subslices}}$  is the number of sub-slices in one RF channel, and  $D_{\text{Type2}}$  is the number of cells allocated to Type 2 data PLPs in one T2-frame across all RF channels as defined above.

A receiver should not assume that RF\_shift can be calculated as described in note 1 but instead should calculate RF\_shift from the signalling fields SUB\_SLICE\_INTERVAL and NUM\_RF.

NOTE 2: Both SUB\_SLICE\_INTERVAL and RF\_SHIFT will be integer numbers as a result of the constraint specified in clause E.2.7.2.2.



### E.2.7.2.5 Mapping the PLP cells to the allocated cell addresses

The data cells from the time interleaver will be mapped to the cells allocated to the sub-slices in order of increasing cell address irrespective of the RF index on which the cells are mapped. The data will be written first to the sub-slice or part of a sub-slice that occurs first in the T2-frame. This means that the receiver will start filling the time deinterleaver starting from the first row. The writing order is illustrated in figure E.9 for data PLP 4, which has a divided sub-slice on RF2.

The maximum number of FEC blocks  $PLP\_NUM\_BLOCKS\_MAX$  which can be allocated by the scheduler to one PLP in one Interleaving Frame will be such that the number of cells  $D_{i,2}$  for one Type-2 PLP in one T2-frame does not exceed  $D_{type2}/N_{RF}$ . Consequently the same cell address will not be mapped to the same PLP on more than one RF channel in the same T2-frame.

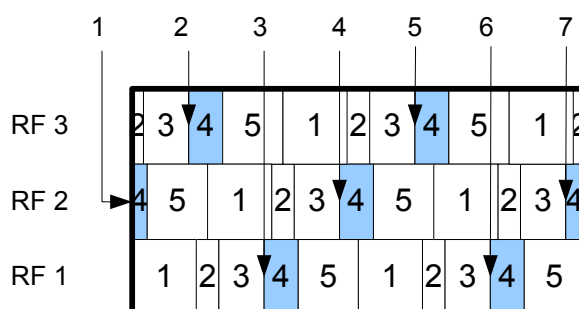


Figure E.9: Writing order of mapping of data PLP 4 to OFDM symbols

### E.2.8 Auxiliary streams and dummy cells

Following the type 2 PLPs, the auxiliary streams (if any) and dummy cells will be added on each RF channel as described in clauses 8.3.7 and 8.3.8. Taken together, the data PLPs of both types, auxiliary streams and dummy cells will exactly fill the available capacity of the T2-frame on each RF channel.

## Annex F (normative): Calculation of the CRC word

The implementation of Cyclic Redundancy Check codes (CRC-codes) allows the detection of transmission errors at the receiver side. For this purpose CRC words shall be included in the transmitted data. These CRC words shall be defined by the result of the procedure described in this annex.

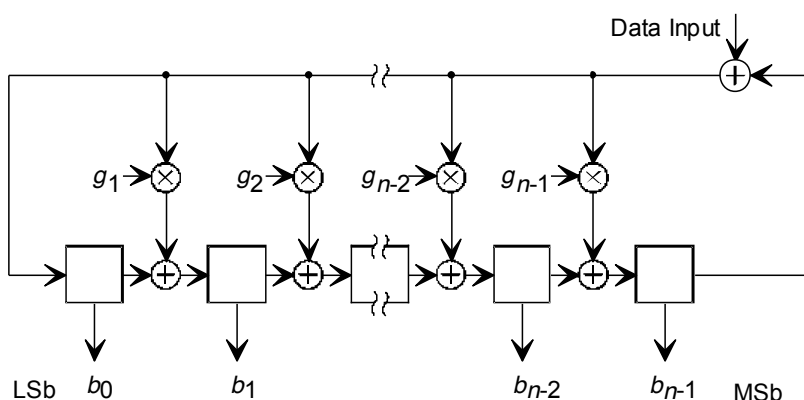
A CRC code is defined by a polynomial of degree  $n$ :

$$G_n(x) = x^n + g_{n-1}x^{n-1} + \dots + g_2x^2 + g_1x + 1$$

with  $n \geq 1$ :

and:  $g_i \in \{0, 1\} \quad i = 1, \dots, n-1$

The CRC calculation may be performed by means of a shift register containing  $n$  register stages, equivalent to the degree of the polynomial (see figure F.1). The stages are denoted by  $b_0 \dots b_{n-1}$ , where  $b_0$  corresponds to 1,  $b_1$  to  $x$ ,  $b_2$  to  $x^2, \dots, b_{n-1}$  to  $x^{n-1}$ . The shift register is tapped by inserting XORs at the input of those stages, where the corresponding coefficients  $g_i$  of the polynomial are '1'.



**Figure F.1: General CRC block diagram**

At the beginning of the CRC-8 calculation (used for GFPS and TS, NM only and BBHEADER), all register stage contents are initialized to zeros.

At the beginning of the CRC-32 calculation (used for the L1-pre and L1-post signalling), all register stage contents are initialized to ones.

After applying the first bit of the data block (MSB first) to the input, the shift clock causes the register to shift its content by one stage towards the MSB stage ( $b_{n-1}$ ), while loading the tapped stages with the result of the appropriate XOR operations. The procedure is then repeated for each data bit. Following the shift after applying the last bit (LSB) of the data block to the input, the shift register contains the CRC word which is then read out. Data and CRC word are transmitted with MSB first.

The CRC codes used in the DVB-T2 system are based on the following polynomials:

- $G_{32}(x) = x^{32} + x^{26} + x^{23} + x^{22} + x^{16} + x^{12} + x^{11} + x^{10} + x^8 + x^7 + x^5 + x^4 + x^2 + x + 1$
- $G_8(x) = x^8 + x^7 + x^6 + x^4 + x^2 + 1$

The assignment of the polynomials to the respective applications is given in each clause.

NOTE: The CRC-32 coder defined in this annex is identical to the implicit encoder defined in [i.4].

## Annex G (normative): Locations of the continual pilots

Table G.1 gives the carrier indices for the continual pilots for each of the pilot patterns in 32K. Table G.2 gives the carrier indices for the additional continual pilots in extended carrier mode. For further details of the use of these, see clause 9.2.4.1.

**Table G.1: Continual pilot groups for each pilot pattern**

Group	PP1	PP2	PP3	PP4	PP5	PP6	PP7	PP8
CP <sub>1</sub> [All modes]	116 255 285 430 518 546 601 646 744 1662 1893 1995 2322 3309 3351 3567 3813 4032 5568 5706	116 318 390 430 474 518 601 646 708 726 1752 1758 1944 2100 2208 2466 3792 5322 5454 5640	116 318 342 426 430 518 582 601 646 816 1758 1764 2400 3450 3504 3888 4020 4932 5154 5250 5292 5334	108 116 144 264 288 430 518 564 636 646 828 2184 3360 3396 3912 4032 4932 5220 5676 5688	108 116 228 430 518 601 646 804 1644 1680 1752 1800 1836 3288 3660 4080 4932 4968 5472		264 360 1848 2088 2112 2160 2256 2280 3936 3960 3984 5016 5136 5208 5664	
CP <sub>2</sub> [2K-32K]	1022 1224 1302 1371 1495 2261 2551 2583 2649 2833 2925 3192 4266 5395 5710 5881 8164 10568 11069 11560 12631 12946 13954 16745 21494	1022 1092 1369 1416 1446 1495 2598 2833 2928 3144 4410 4800 5710 5881 6018 6126 10568 11069 11560 12946 13954 16681	1022 1495 2261 2551 2802 2820 2833 2922 4422 4752 4884 5710 8164 10568 11069 11560 12631 12946 16745 21494	601 1022 1092 1164 1369 1392 1452 1495 2261 2580 2833 3072 4320 4452 5710 5881 6048 10568 11515 12946 13954 16681	852 1022 1495 2508 2551 2604 2664 2736 2833 3120 4248 4512 4836 5710 5940 6108 8164 10568 11069 11560 12946 13954 21494		116 430 518 601 646 1022 1296 1368 1369 1495 2833 3024 4416 4608 4776 5710 5881 6168 7013 8164 10568 10709 11515 12946 15559 23239 24934 25879 26308 26674	
CP <sub>3</sub> [4K-32K]		2261 8164	13954	8164	648 4644 16745		456 480 2261 6072 17500	
CP <sub>4</sub> [8K-32K]		10709 19930		10709 19930	12631		1008 6120 13954	116 132 180 430 518 601 646 1022 1266 1369 1495 2261 2490 2551 2712 2833 3372 3438 4086 4098 4368 4572 4614 4746 4830 4968 5395 5710 5881 7649 8164 10568 11069 11560 12631 12946

Group	PP1	PP2	PP3	PP4	PP5	PP6	PP7	PP8
								13954 15760 16612 16745 17500 19078 19930 21494 22867 25879 26308
CP <sub>5</sub> [16K-32K]	1369 7013 7215 7284 7649 7818 8025 8382 8733 8880 9249 9432 9771 10107 10110 10398 10659 10709 10785 10872 11115 11373 11515 11649 11652 12594 12627 12822 12984 15760 16612 17500 18358 19078 19078 19078 19930 20261 20261 20422 20422 22124 22867 23239 24934 25879 26308 26674	6744 7013 7020 7122 7308 7649 7674 7752 7764 8154 8190 8856 8922 9504 9702 9882 9924 10032 10092 10266 10302 10494 10530 10716 11016 11076 11160 11286 11436 11586 12582 13002 17500 18358 19078 19930 20261 23239 24073 24934 25879 26308	1369 5395 5881 6564 6684 7013 7649 8376 8544 8718 8856 9024 9132 9498 9774 9840 10302 10512 10566 10770 10914 11340 11418 11730 11742 12180 12276 12474 12486 15760 16612 17500 18358 19078 19930 20261 20422 22124 22867 23239 24934 25879 26308 26674	6612 6708 7013 7068 7164 7224 7308 7464 7649 7656 7716 7752 7812 7860 8568 8808 8880 9072 9228 9516 9696 9996 10560 10608 10728 11148 11232 11244 11496 11520 11664 11676 11724 11916 17500 18358 19078 21284 22124 23239 24073 24934 25879 26308	1369 2261 5395 5881 6552 6636 6744 6900 7032 7296 7344 7464 7644 7649 7668 7956 8124 8244 8904 8940 8976 9216 9672 9780 10224 10332 10709 10776 10944 11100 11292 11364 11496 11532 11904 12228 12372 12816 15760 16612 17500 19078 22867 25879	116 384 408 518 601 646 672 960 1022 1272 1344 1369 1495 1800 2040 2261 2833 3192 3240 3768 3864 3984 4104 4632 4728 4752 4944 5184 5232 5256 5376 5592 5616 5710 5808 5881 6360 6792 6960 7013 7272 7344 7392 7536 7649 7680 7800 8064 8160 8164 8184 8400 8808 8832 9144 9648 9696 9912 10008 10200 10488 10568 10656 10709 11088 11160 11515 11592 12048 12264 12288 12312 12552 12672 12946 13954 15559 16681 17500 19078 20422 21284 22124 23239 24934	6984 7032 7056 7080 7152 7320 7392 7536 7649 7704 7728 7752 8088 8952 9240 9288 9312 9480 9504 9840 9960 10320 10368 10728 10752 11448 11640 11688 11808 12192 12240 12480 12816 16681 22124	6720 6954 7013 7026 7092 7512 7536 7596 7746 7758 7818 7986 8160 8628 9054 9096 9852 9924 10146 10254 10428 10704 11418 11436 11496 11550 11766 11862 12006 12132 12216 12486 12762 18358 20261 20422 22124 23239 24934

Group	PP1	PP2	PP3	PP4	PP5	PP6	PP7	PP8	
						25879 26308 26674			
CP <sub>6</sub> [32K only]		13164 13206 13476 13530 13536 13764 13848 13938 13968 14028 14190 14316 14526 14556 14562 14658 14910 14946 15048 15186 15252 15468 15540 15576 15630 15738 15840 16350 16572 16806 17028 17064 17250 17472 17784 17838 18180 18246 18480 18900 18960 19254 19482 19638 19680 20082 20310 20422 20454 20682 20874 21240 21284 21444 21450 21522 21594 21648 21696 21738 22416 22824 23016 23124		13080 13152 13260 13380 13428 13572 13884 13956 14004 14016 14088 14232 14304 14532 14568 14760 14940 15168 15288 15612 15684 15888 16236 16320 16428 16680 16812 16908 17184 17472 17508 17580 17892 17988 18000 18336 18480 18516 19020 19176 19188 19320 19776 19848 20112 20124 20184 20388 20532 20556 20676 20772 21156 21240 21276 21336 21384 21816 21888 22068 22092 22512 22680 22740			13080 13368 13464 13536 13656 13728 13824 14112 14232 14448 14472 14712 14808 14952 15000 15336 15360 15408 15600 15624 15648 16128 16296 16320 16416 16536 16632 16824 16848 17184 17208 17280 17352 17520 17664 17736 17784 18048 18048 18768 18816 18840 19296 19392 19584 19728 19752 19776 20136 20184 20208 20256 21096 21216 21360 21408 21744 21768 22200 22224 22320 22344 22416 22848 22968	13416 13440 13536 13608 13704 13752 14016 14040 14112 14208 14304 14376 14448 14616 14712 14760 14832 14976 15096 15312 15336 15552 15816 15984 16224 16464 16560 17088 17136 17256 17352 17400 17448 17544 17928 18048 18336 18456 18576 18864 19032 19078 19104 19320 19344 19416 19488 19920 19930 20424 20664 20808 21168 21284 21360 21456 21816 22128 22200 22584 22608 22824 22848	10709 11515 13254 13440 13614 13818 14166 14274 14304 14364 14586 14664 15030 15300 15468 15474 15559 15732 15774 16272 16302 16428 16500 16662 16681 16872 17112 17208 17862 18036 18282 18342 18396 18420 18426 18732 19050 19296 19434 19602 19668 19686 19728 19938 20034 21042 21120 21168 21258 21284 21528 21594 21678 21930 21936 21990 22290 22632 22788 23052 23358 23448 23454 23706

Group	PP1	PP2	PP3	PP4	PP5	PP6	PP7	PP8
		23196		22800		23016	22944	23772
		23238		22836		23040	22992	24048
		23316		22884		23496	23016	24072
		23418		23304		23688	23064	24073
		23922		23496		23904	23424	24222
		23940		23568		24048	23448	24384
		24090		23640		24168	23472	24402
		24168		24120		24360	23592	24444
		24222		24168		24408	24192	24462
		24324		24420		24984	24312	24600
		24342		24444		25152	24360	24738
		24378		24456		25176	24504	24804
		24384		24492		25224	24552	24840
		24540		24708		25272	24624	24918
		24744		24864		25344	24648	24996
		24894		25332		25416	24672	25038
		24990		25536		25488	24768	25164
		25002		25764		25512	24792	25314
		25194		25992		25536	25080	25380
		25218		26004		25656	25176	25470
		25260		26674		25680	25224	25974
		25566		26944		25752	25320	26076
		26674				25992	25344	26674
		26944				26016	25584	26753
							25680	26944
							25824	
							26064	
							26944	

**Table G.2: Locations of additional continual pilots in extended carrier mode**

FFT size	PP1	PP2	PP3	PP4	PP5	PP6	PP7	PP8
8K	None	6820 6847 6869 6898	6820 6869	6820 6869	None	NA	6820 6833 6869 6887 6898	6820 6833 6869 6887 6898
16K	13636 13724 13790 13879	13636 13790	13636 13790	13636 13790	13636 13790	13636 13790	13636 13724 13879	13636 13724 13879
32K	NA	27268 27688		27268 27688	NA	27268 27448 27688 27758	27268 27688	27268 27368 27448 27580 27688 27758

## Annex H (normative): Reserved carrier indices for PAPR reduction

Table H.1 gives the indices of the reserved carriers for the P2 symbol. Table H.2 gives the starting indices for the reserved carriers for pilot patterns PP1-8. For further details of the use of these, see clauses 9.3 and 9.6.2.

**Table H.1: Reserved carrier indices for P2 symbol**

FFT size (Number of reserved carriers)	Reserved Carrier Indices
1K (10)	116, 130, 134, 157, 182, 256, 346, 478, 479, 532
2K (18)	113, 124, 262, 467, 479, 727, 803, 862, 910, 946, 980, 1201, 1322, 1342, 1396, 1397, 1562, 1565
4K (36)	104, 116, 119, 163, 170, 173, 664, 886, 1064, 1151, 1196, 1264, 1531, 1736, 1951, 1960, 2069, 2098, 2311, 2366, 2473, 2552, 2584, 2585, 2645, 2774, 2846, 2882, 3004, 3034, 3107, 3127, 3148, 3191, 3283, 3289
8K (72)	106, 109, 110, 112, 115, 118, 133, 142, 163, 184, 206, 247, 445, 461, 503, 565, 602, 656, 766, 800, 922, 1094, 1108, 1199, 1258, 1726, 1793, 1939, 2128, 2714, 3185, 3365, 3541, 3655, 3770, 3863, 4066, 4190, 4282, 4565, 4628, 4727, 4882, 4885, 5143, 5192, 5210, 5257, 5261, 5459, 5651, 5809, 5830, 5986, 6020, 6076, 6253, 6269, 6410, 6436, 6467, 6475, 6509, 6556, 6611, 6674, 6685, 6689, 6691, 6695, 6698, 6701
16K (144)	104, 106, 107, 109, 110, 112, 113, 115, 116, 118, 119, 121, 122, 125, 128, 131, 134, 137, 140, 143, 161, 223, 230, 398, 482, 497, 733, 809, 850, 922, 962, 1196, 1256, 1262, 1559, 1691, 1801, 1819, 1937, 2005, 2095, 2308, 2383, 2408, 2425, 2428, 2479, 2579, 2893, 2902, 3086, 3554, 4085, 4127, 4139, 4151, 4163, 4373, 4400, 4576, 4609, 4952, 4961, 5444, 5756, 5800, 6094, 6208, 6658, 6673, 6799, 7208, 7682, 8101, 8135, 8230, 8692, 8788, 8933, 9323, 9449, 9478, 9868, 10192, 10261, 10430, 10630, 10685, 10828, 10915, 10930, 10942, 11053, 11185, 11324, 11369, 11468, 11507, 11542, 11561, 11794, 11912, 11974, 11978, 12085, 12179, 12193, 12269, 12311, 12758, 12767, 12866, 12938, 12962, 12971, 13099, 13102, 13105, 13120, 13150, 13280, 13282, 13309, 13312, 13321, 13381, 13402, 13448, 13456, 13462, 13463, 13466, 13478, 13492, 13495, 13498, 13501, 13502, 13504, 13507, 13510, 13513, 13514, 13516
32K (288)	104, 106, 107, 109, 110, 112, 113, 115, 118, 121, 124, 127, 130, 133, 136, 139, 142, 145, 148, 151, 154, 157, 160, 163, 166, 169, 172, 175, 178, 181, 184, 187, 190, 193, 196, 199, 202, 205, 208, 211, 404, 452, 455, 467, 509, 539, 568, 650, 749, 1001, 1087, 1286, 1637, 1823, 1835, 1841, 1889, 1898, 1901, 2111, 2225, 2252, 2279, 2309, 2315, 2428, 2452, 2497, 2519, 3109, 3154, 3160, 3170, 3193, 3214, 3298, 3331, 3346, 3388, 3397, 3404, 3416, 3466, 3491, 3500, 3572, 4181, 4411, 4594, 4970, 5042, 5069, 5081, 5086, 5095, 5104, 5320, 5465, 5491, 6193, 6541, 6778, 6853, 6928, 6934, 7030, 7198, 7351, 7712, 7826, 7922, 8194, 8347, 8350, 8435, 8518, 8671, 8861, 8887, 9199, 9980, 10031, 10240, 10519, 10537, 10573, 10589, 11078, 11278, 11324, 11489, 11642, 12034, 12107, 12184, 12295, 12635, 12643, 12941, 12995, 13001, 13133, 13172, 13246, 13514, 13522, 13939, 14362, 14720, 14926, 15338, 15524, 15565, 15662, 15775, 16358, 16613, 16688, 16760, 17003, 17267, 17596, 17705, 18157, 18272, 18715, 18994, 19249, 19348, 20221, 20855, 21400, 21412, 21418, 21430, 21478, 21559, 21983, 21986, 22331, 22367, 22370, 22402, 22447, 22535, 22567, 22571, 22660, 22780, 22802, 22844, 22888, 22907, 23021, 23057, 23086, 23213, 23240, 23263, 23333, 23369, 23453, 23594, 24143, 24176, 24319, 24325, 24565, 24587, 24641, 24965, 25067, 25094, 25142, 25331, 25379, 25465, 25553, 25589, 25594, 25655, 25664, 25807, 25823, 25873, 25925, 25948, 26002, 26008, 26102, 26138, 26141, 26377, 26468, 26498, 26510, 26512, 26578, 26579, 26588, 26594, 26597, 26608, 26627, 26642, 26767, 26776, 26800, 26876, 26882, 26900, 26917, 26927, 26951, 26957, 26960, 26974, 26986, 27010, 27013, 27038, 27044, 27053, 27059, 27061, 27074, 27076, 27083, 27086, 27092, 27094, 27098, 27103, 27110, 27115, 27118, 27119, 27125, 27128, 27130, 27133, 27134, 27140, 27143, 27145, 27146, 27148, 27149

Table H.2: Reserved carrier indices for PP 1, 2, 3, 4, 5, 6, 7 and 8

FFT size (Number of reserved carriers)	Reserved Carrier Indices
1K (10)	109, 117, 122, 129, 139, 321, 350, 403, 459, 465
2K (18)	250, 404, 638, 677, 700, 712, 755, 952, 1125, 1145, 1190, 1276, 1325, 1335, 1406, 1431, 1472, 1481
4K (36)	170, 219, 405, 501, 597, 654, 661, 745, 995, 1025, 1319, 1361, 1394, 1623, 1658, 1913, 1961, 1971, 2106, 2117, 2222, 2228, 2246, 2254, 2361, 2468, 2469, 2482, 2637, 2679, 2708, 2825, 2915, 2996, 3033, 3119
8K (72)	111, 115, 123, 215, 229, 392, 613, 658, 831, 842, 997, 1503, 1626, 1916, 1924, 1961, 2233, 2246, 2302, 2331, 2778, 2822, 2913, 2927, 2963, 2994, 3087, 3162, 3226, 3270, 3503, 3585, 3711, 3738, 3874, 3902, 4013, 4017, 4186, 4253, 4292, 4339, 4412, 4453, 4669, 4910, 5015, 5030, 5061, 5170, 5263, 5313, 5360, 5384, 5394, 5493, 5550, 5847, 5901, 5999, 6020, 6165, 6174, 6227, 6245, 6314, 6316, 6327, 6503, 6507, 6545, 6565
16K (144)	109, 122, 139, 171, 213, 214, 251, 585, 763, 1012, 1021, 1077, 1148, 1472, 1792, 1883, 1889, 1895, 1900, 2013, 2311, 2582, 2860, 2980, 3011, 3099, 3143, 3171, 3197, 3243, 3257, 3270, 3315, 3436, 3470, 3582, 3681, 3712, 3767, 3802, 3979, 4045, 4112, 4197, 4409, 4462, 4756, 5003, 5007, 5036, 5246, 5483, 5535, 5584, 5787, 5789, 6047, 6349, 6392, 6498, 6526, 6542, 6591, 6680, 6688, 6785, 6860, 7134, 7286, 7387, 7415, 7417, 7505, 7526, 7541, 7551, 7556, 7747, 7814, 7861, 7880, 8045, 8179, 8374, 8451, 8514, 8684, 8698, 8804, 8924, 9027, 9113, 9211, 9330, 9479, 9482, 9487, 9619, 9829, 10326, 10394, 10407, 10450, 10528, 10671, 10746, 10774, 10799, 10801, 10912, 11113, 11128, 11205, 11379, 11459, 11468, 11658, 11776, 11791, 11953, 11959, 12021, 12028, 12135, 12233, 12407, 12441, 12448, 12470, 12501, 12548, 12642, 12679, 12770, 12788, 12899, 12923, 12939, 13050, 13103, 13147, 13256, 13339, 13409
32K (288)	164, 320, 350, 521, 527, 578, 590, 619, 635, 651, 662, 664, 676, 691, 723, 940, 1280, 1326, 1509, 1520, 1638, 1682, 1805, 1833, 1861, 1891, 1900, 1902, 1949, 1967, 1978, 1998, 2006, 2087, 2134, 2165, 2212, 2427, 2475, 2555, 2874, 3067, 3091, 3101, 3146, 3188, 3322, 3353, 3383, 3503, 3523, 3654, 3856, 4150, 4158, 4159, 4174, 4206, 4318, 4417, 4629, 4631, 4875, 5104, 5106, 5111, 5131, 5145, 5146, 5177, 5181, 5246, 5269, 5458, 5474, 5500, 5509, 5579, 5810, 5823, 6058, 6066, 6098, 6411, 6741, 6775, 6932, 7103, 7258, 7303, 7413, 7586, 7591, 7634, 7636, 7655, 7671, 7675, 7756, 7760, 7826, 7931, 7937, 7951, 8017, 8061, 8071, 8117, 8317, 8321, 8353, 8806, 9010, 9237, 9427, 9453, 9469, 9525, 9558, 9574, 9584, 9820, 9973, 10011, 10043, 10064, 10066, 10081, 10136, 10193, 10249, 10511, 10537, 11083, 11350, 11369, 11428, 11622, 11720, 11924, 11974, 11979, 12944, 12945, 13009, 13070, 13110, 13257, 13364, 13370, 13449, 13503, 13514, 13520, 13583, 13593, 13708, 13925, 14192, 14228, 14235, 14279, 14284, 14370, 14393, 14407, 14422, 14471, 14494, 14536, 14617, 14829, 14915, 15094, 15138, 15155, 15170, 15260, 15283, 15435, 15594, 15634, 15810, 16178, 16192, 16196, 16297, 16366, 16498, 16501, 16861, 16966, 17039, 17057, 17240, 17523, 17767, 18094, 18130, 18218, 18344, 18374, 18657, 18679, 18746, 18772, 18779, 18786, 18874, 18884, 18955, 19143, 19497, 19534, 19679, 19729, 19738, 19751, 19910, 19913, 20144, 20188, 20194, 20359, 20490, 20500, 20555, 20594, 20633, 20656, 21099, 21115, 21597, 22139, 22208, 22244, 22530, 22547, 22562, 22567, 22696, 22757, 22798, 22854, 22877, 23068, 23102, 23141, 23154, 23170, 23202, 23368, 23864, 24057, 24215, 24219, 24257, 24271, 24325, 24447, 25137, 25590, 25702, 25706, 25744, 25763, 25811, 25842, 25853, 25954, 26079, 26158, 26285, 26346, 26488, 26598, 26812, 26845, 26852, 26869, 26898, 26909, 26927, 26931, 26946, 26975, 26991, 27039



---

## Annex I (normative): T2-Lite

### I.1 Overview

Version 1.3.1 of the present document introduced a T2-Lite profile. This profile is intended to allow simpler receiver implementations for very low capacity applications such as mobile broadcasting, although it may also be received by conventional stationary receivers. T2-Lite is based on a limited sub-set of the modes of the T2-base profile, and by avoiding modes which require the most complexity and memory, allows much more efficient receiver designs to be used. The limitations imposed for T2-Lite are described in this annex. Except where indicated otherwise in this annex, all other features in the remainder of the present document shall also apply.

A T2-Lite signal is identified by using one of the T2-Lite S1 codes in the P1 signalling (see clause 7.2.1 and table 18). However a T2-base signal which is compatible with the restrictions of this annex (except that it uses the T2-base profile P1 signalling bits) is also suitable for being received with a T2-Lite receiver, and is signalled by setting the T2\_BASE\_LITE bit (see clause 7.2.2).

**NOTE:** One possible scenario for the use of T2-Lite involves simulcasting two different versions of the same service, with different bit-rates and levels of protection (a higher bit-rate less well protected version and a lower rate, more highly protected version), to provide a fall-back signal towards the edges of a service-area or in critical locations such as indoor rooms or shadowed areas. This specification does not require a receiver to support a seam-less handover between two such streams, since this would require the simultaneous decoding of two data PLPs: a T2-Lite receiver is only required to decode one data PLP and its associated common PLP. Such a scenario would be facilitated by the appropriate PSI/SI signalling.

As described in clause 4.1, and explained further in clause I.9, the T2-Lite signal may be multiplexed together with a T2-base signal (and/or with other signals), with each signal being transmitted in the other's FEF parts. So, for example, a complete RF signal may be formed by combining a 32K FFT T2-base profile signal carrying HDTV services for fixed receivers using 256-QAM modulation, together with a T2-Lite profile signal using an 8K FFT and QPSK modulation to serve mobile receivers from the same network.

---

### I.2 In-band signalling

For T2-Lite, the same rules apply to in-band signalling as described in clause 5.2.3, except that in-band type B shall always be used (see clause 5.2.3.2).

---

### I.3 FEC encoding for T2-Lite

The FEC encoding for the T2-Lite profile shall be as described in clause 6.1, except for the modification described in this clause.

The set of LDPC codes that shall be used for T2-Lite is given in table I.1, and only the short FECFRAME ( $M_{ldpc} = 16$  200 bits) may be used. No other coding parameters may be used.

Table I.1: T2-Lite coding parameters (for short FECFRAME  $N_{ldpc} = 16\ 200$ )

LDPC Code identifier	BCH Uncoded Block $K_{bch}$	BCH coded block $N_{bch}$ LDPC Uncoded Block $K_{ldpc}$	BCH t-error correction	$N_{bch} - K_{bch}$	Effective LDPC Rate $K_{ldpc}/16\ 200$	LDPC Coded Block $N_{ldpc}$
1/4 (see note)	3 072	3 240	12	168	1/5	16 200
1/3	5 232	5 400	12	168	1/3	16 200
2/5	6 312	6 480	12	168	2/5	16 200
1/2	7 032	7 200	12	168	4/9	16 200
3/5	9 552	9 720	12	168	3/5	16 200
2/3	10 632	10 800	12	168	2/3	16 200
3/4	11 712	11 880	12	168	11/15	16 200

NOTE: This code rate is only used for protection of L1-pre signalling and not for data.

When QPSK modulation is used together with code rates 1/3 or 2/5, the parity interleaver described in clause 6.1.3 shall be used. The complete set of combinations of bit interleavers that shall be used for T2-Lite is therefore given by table I.2.

Table I.2: Use of bit interleavers for T2-Lite profile

LDPC Code identifier	Effective LDPC Rate $K_{ldpc}/16\ 200$	Modulation	
		QPSK	16-QAM, 64-QAM or 256-QAM
1/3	1/3	Parity only	Parity & column twist
2/5	2/5	Parity only	Parity & column twist
1/2	4/9	None	Parity & column twist
3/5	3/5	None	Parity & column twist
2/3	2/3	None	Parity & column twist
3/4	11/15	None	Parity & column twist

## 1.4 Bit to cell word de-multiplexer

For T2-Lite, the bit to cell word de-multiplexer given in clause 6.2.1 shall be used except that, for code-rates 1/3 and 2/5, the parameters from table I.3 shall be used instead of the values from table 13.

Table I.3(a): Parameters for de-multiplexing of bits to sub-streams for code rates 1/3

Modulation format	QPSK											
Input bit-number, $di \bmod N_{substreams}$	0	1										
Output bit-number, $e$	0	1										
Modulation format	16-QAM											
Input bit-number, $di \bmod N_{substreams}$	0	1	2	3	4	5	6	7				
Output bit-number, $e$	6	0	3	4	5	2	1	7				
Modulation format	64-QAM											
Input bit-number, $di \bmod N_{substreams}$	0	1	2	3	4	5	6	7	8	9	10	11
Output bit-number, $e$	4	2	0	5	6	1	3	7	8	9	10	11
Modulation format	256-QAM											
Input bit-number, $di \bmod N_{substreams}$	0	1	2	3	4	5	6	7				
Output bit-number, $e$	4	0	1	2	5	3	6	7				

Table I.3(b): Parameters for de-multiplexing of bits to sub-streams for code rates 2/5

Modulation format	QPSK											
Input bit-number, $di \bmod N_{substreams}$	0	1										
Output bit-number, $e$	0	1										
Modulation format	16-QAM											
Input bit-number, $di \bmod N_{substreams}$	0	1	2	3	4	5	6	7				
Output bit-number, $e$	7	5	4	0	3	1	2	6				
Modulation format	64-QAM											
Input bit-number, $di \bmod N_{substreams}$	0	1	2	3	4	5	6	7	8	9	10	11
Output bit-number, $e$	4	0	1	6	2	3	5	8	7	10	9	11
Modulation format	256-QAM											
Input bit-number, $di \bmod N_{substreams}$	0	1	2	3	4	5	6	7				
Output bit-number, $e$	4	0	5	1	2	3	6	7				

## I.5 Modulation limitations for T2-Lite

256-QAM modulation shall not be used with code rates 2/3 or 3/4 for T2-Lite. Rotated constellations shall never be used with 256-QAM modulation for T2-Lite. Therefore the complete set of allowed combinations of modulation, code rate and rotated constellations to be used for data is given by table I.4.

**Table I.4: Combinations of modulation, code rate for which rotated constellations may be used for data with T2-Lite profile**

LDPC Code identifier	Effective LDPC Rate $K_{ldpc}/16\ 200$	Modulation			
		QPSK	16-QAM	64-QAM	256-QAM
1/3	1/3	✓	✓	✓	✗
2/5	2/5	✓	✓	✓	✗
1/2	4/9	✓	✓	✓	✗
3/5	3/5	✓	✓	✓	✗
2/3	2/3	✓	✓	✓	NA
3/4	11/15	✓	✓	✓	NA

NOTE: ✓ means that this combination may be used with or without constellation rotation  
✗ means that constellation rotation shall not be used for this combination  
NA means that this combination shall not be used

## I.6 T2-Lite L1-signalling

A T2-Lite profile signal shall be signalled with one of the S1 codes T2\_LITE\_SISO or T2\_LITE\_MISO (see table 18)

A longer FEF\_LENGTH may be used with T2-Lite. The full length of the FEF is signalled by the combination of the FEF\_LENGTH\_MSB and FEF\_LENGTH fields. See clause 7.2.3.1.

The L1-post signalling field PLP\_COD is modified to include the different code rates for T2-Lite. The code rate of the relevant PLP shall be signalled according to table 32.

## I.7 T2-Lite mode limitations

A limited sub-set of modes shall be used for T2-Lite. The mode limitations apply to FFT size, pilot patterns and to the allowed combinations of these parameters and guard interval. There are further limitations applying to other parameters which are described in other clauses of this annex.

### I.7.1 FFT size limitations

The FFT sizes 1K and 32K shall not be used for T2-Lite. Therefore the allowed set of FFT sizes is restricted to 2K, 4K, 8K and 16K.

### I.7.2 Pilot pattern limitations

Scattered pilot pattern PP8 shall not be used for T2-Lite.

### I.7.3 Limitations on mode combinations

A reduced set of combinations of FFT size, guard interval and pilot pattern is used for T2-Lite. The complete set of allowed combinations of these parameters for T2-Lite is given in tables I.5 and I.6.

**Table I.5: Scattered pilot pattern to be used for T2-Lite for each allowed combination of FFT size and guard interval in SISO mode**

FFT size	Guard interval						
	1/128	1/32	1/16	19/256	1/8	19/128	1/4
16K	PP7	PP7 PP6	PP4 PP5	PP2 PP4 PP5	PP2 PP3	PP2 PP3	PP1
8K	PP7	PP7 PP4	PP4 PP5	PP4 PP5	PP2 PP3	PP2 PP3	PP1
4K, 2K	NA	PP7 PP4	PP4 PP5	NA	PP2 PP3	NA	PP1

**Table I.6: Scattered pilot pattern to be used for T2-Lite for each allowed combination of FFT size and guard interval in MISO mode**

FFT size	Guard interval						
	1/128	1/32	1/16	19/256	1/8	19/128	1/4
16K	PP4 PP5	PP4	PP3	PP3	PP1	PP1	NA
8K	PP4 PP5	PP4 PP5	PP3	PP3	PP1	PP1	NA
4K, 2K	NA	PP4 PP5	PP3	NA	PP1	NA	NA

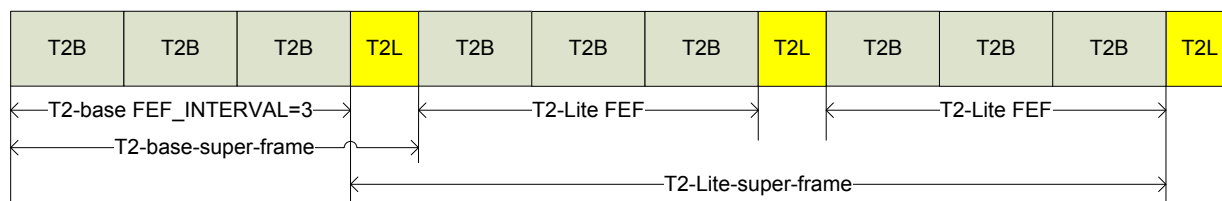
## I.8 T2-Lite time interleaver memory

The time interleaving memory is roughly halved for T2-Lite. The parameter  $M_{TI}$ , as defined in clause 6.5.2, shall have a value of  $2^{18}$  for T2-Lite.

## I.9 T2-Lite signal structure

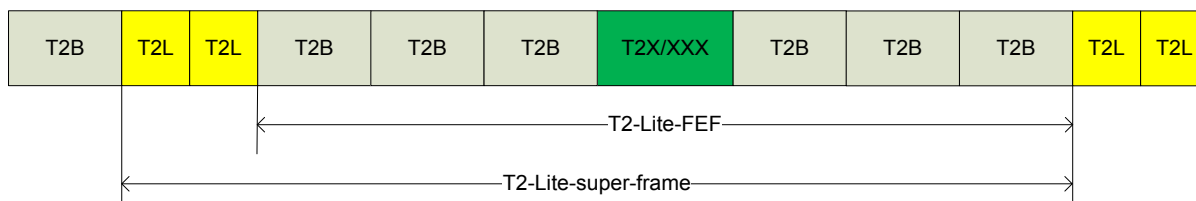
The T2-Lite signal may either be transmitted as a stand-alone signal (i.e. without FEF parts), or as a T2-Lite signal with FEF parts. When a T2 signal using another profile is transmitted within the FEF part of the T2-Lite signal each signal (T2-Lite and the other T2 signal) will appear as though it is being transmitted in the FEF part of the other, and shall be signalled accordingly. For example, if a T2-base signal is being transmitted with T2-Lite in its FEF parts, and there are 3 T2-base frames followed by 1 T2-Lite frame, the T2-base signal will have a FEF\_INTERVAL of 3, whereas the T2-Lite signal will have a FEF\_INTERVAL of 1, as shown in figure 55(a). The T2-frames of the T2-base signal are labelled as 'T2B' and the T2-frames of the T2-Lite signal are labelled 'T2L'. Note that in this case the FEFs of the T2-Lite signal will have 3 P1 symbols. The maximum duration of a FEF part of a T2-Lite signal is 1 second. Note also that a super-frame must contain at least 2 T2-frames, and so the minimum lengths of the super-frames are shown in each case. Super-frames may contain more than one FEF, and, if FEFs are being used, must finish with a FEF.

The length of a T2-Lite super-frame shall have the same restrictions as a T2-base signal.



**Figure 55(a) Example of a composite T2-base and T2-Lite signal**

Another example of a composite frame structure is shown in figure 55(b), showing the use of either a third (as yet undefined) profile, or another signal altogether. In this case, the green frame represents either the T2-frame of the undefined profile ('T2X') or the other signal ('XXX'). The T2X/XXX FEF part would be twice the length of the T2L frames, giving equal length FEF parts from the point of view of the T2B frames.



**Figure 55(b) Example of a composite T2-base and T2-Lite signal**

## I.10 T2-Lite PLP data rate limitations

The maximum data rate for a PLP is defined in terms of the parameters for that PLP and the frame structure:

$$\text{Maximum data rate} = \frac{(K_{\text{bch}} - 80) \times N_{\text{BLOCKS\_IF\_MAX}}}{P_I \times I_{\text{JUMP}} \left( T_F + \frac{T_{\text{FEF}}}{I_{\text{FEF}}} \right)}$$

For T2-Lite, the sum of the maximum data rates for any data PLP and if present, its common PLP, shall not exceed 4 Mbit/s. Additionally, for the TS case, the maximum input TS bit rate shall be 4 Mbit/s.

---

## I.11 T2-Lite receiver buffer model limitations

In the receiver buffer model for T2-Lite, the rate at which the FEC chain can process cells is reduced to allow simplifications in the FEC decoder implementation. The value of  $R_{\text{cell}}$ , as defined in clause C.1.1, shall be reduced to the value given in table I.7.

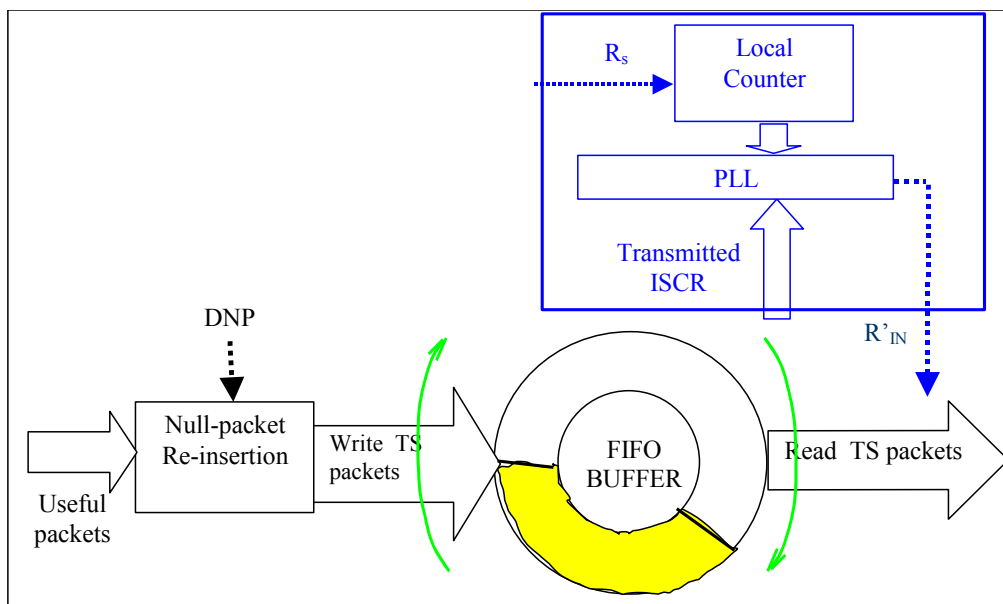
**Table I.7: Value of  $R_{\text{cell}}$  for different constellations**

<b>Constellation</b>	<b><math>R_{\text{cell}}</math> (cells/s)</b>
QPSK	$7.6 \times 10^6$
16-QAM	$4.0 \times 10^6$
64-QAM	$2.7 \times 10^6$
256-QAM	$2.0 \times 10^6$

## Annex J (informative): Transport Stream regeneration and clock recovery using ISCR

When the modulator operates in a mode that employs null-packet deletion, the receiver may regenerate the Transport Stream by inserting, before each useful packet, DNP in the reception FIFO buffer. As shown in figure J.1, the Transport Stream clock  $R'_{IN}$  may be recovered by means of a Phase Locked Loop (PLL). The recovered modulator sampling rate  $R_s$  may be used to clock a local counter (which by definition runs synchronously with the input stream synchronization counter of figure C.1). The PLL compares the local counter content with the transmitted ISCR of each TS packet, and the phase difference may be used to adjust the  $R'_{IN}$  clock. In this way  $R'_{IN}$  remains constant, and the reception FIFO buffer automatically compensates the chain delay variations. Since the reception FIFO buffer is not self-balancing, the TTO and the BUFS information may be used to set its initial state.

As an alternative, when dynamic variations of the end-to-end delay and bit-rate may be acceptable by the source decoders, the receiver buffer filling condition may be used to drive the PLL. In this case the reception buffer is self-balancing (in steady state half of cells are filled), and the ISSY field may be omitted at the transmitting side.

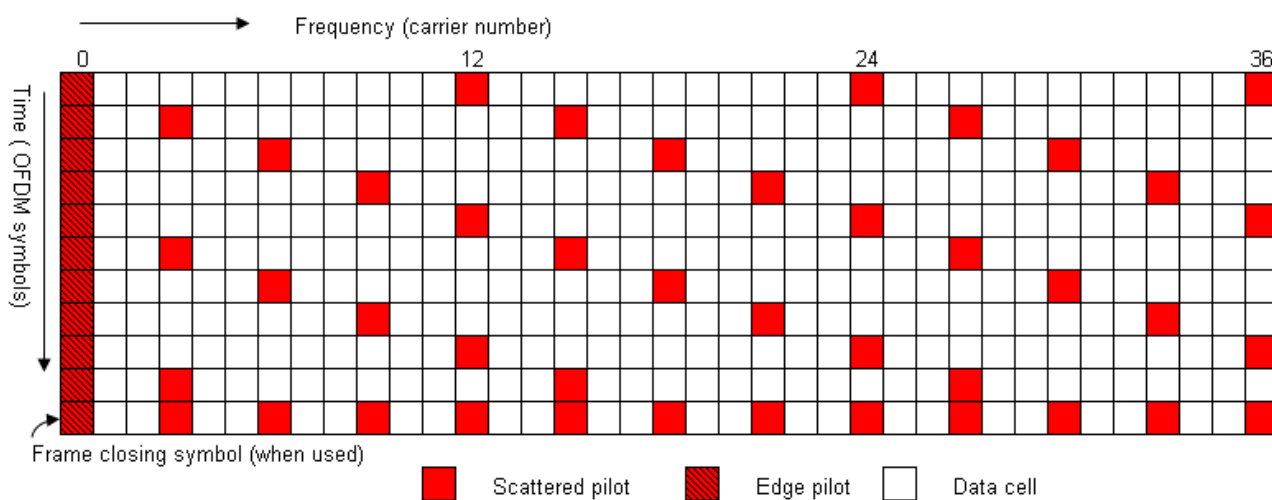


**Figure J.1: Example receiver block diagram for Null-packet re-insertion and  $R_{TS}$  clock recovery**

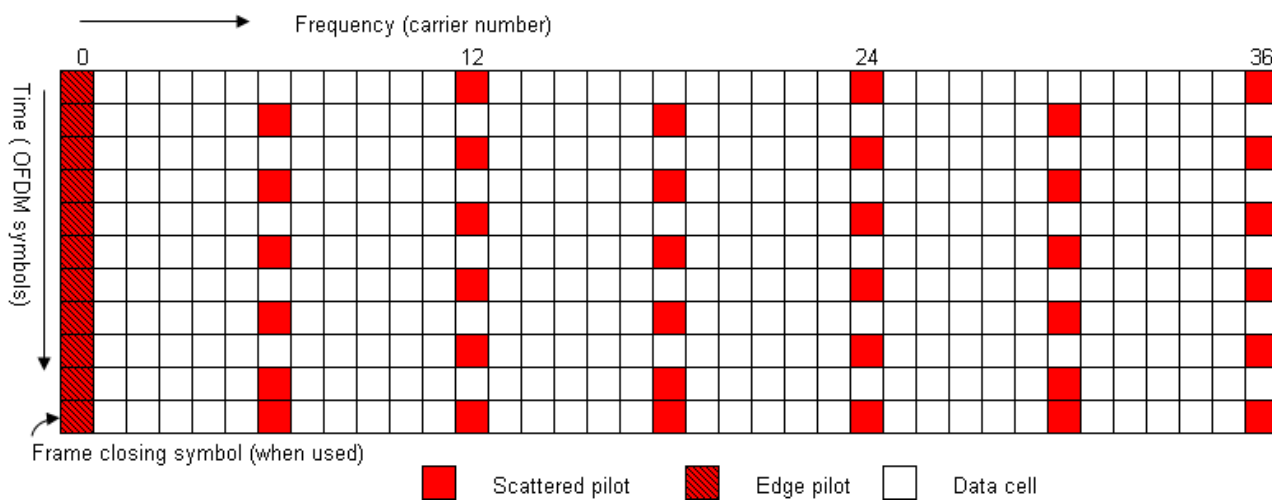
## Annex K (informative): Pilot patterns

This annex illustrates each of the scattered pilot patterns, showing the pattern of pilots at the low frequency edge of the ensemble and for the last few symbols of a frame. It shows first the patterns in SISO mode (figures K.1 to K.8) and then the patterns in MISO mode (figures K.9 to K.16). Continual pilots and reserved carriers are not shown.

The patterns of pilots around the P2 symbol(s) are shown in figures K.17 and K.18.

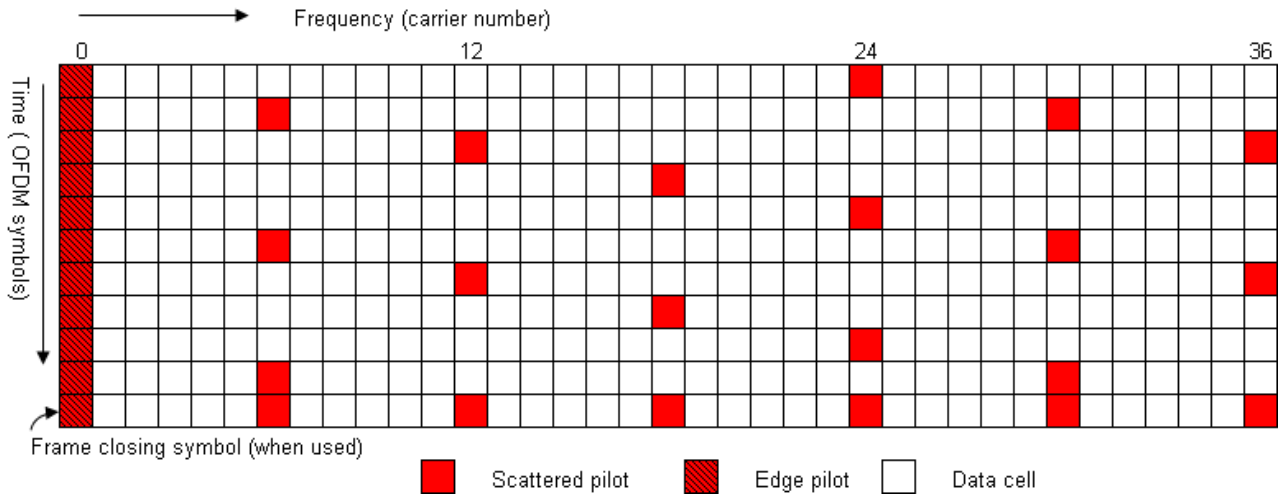


**Figure K.1: Scattered pilot pattern PP1 (SISO)**

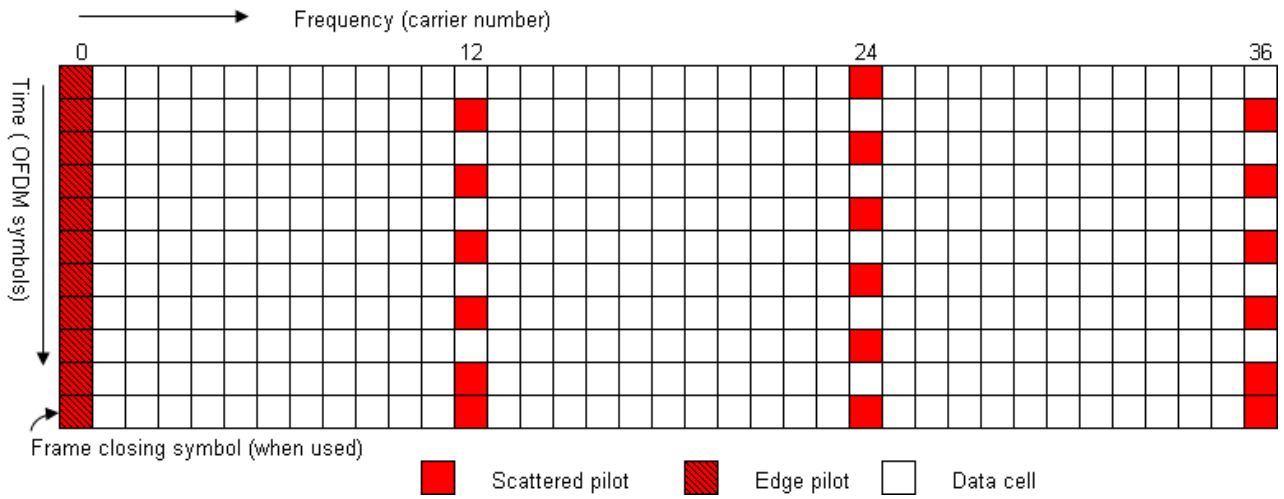


**Figure K.2: Scattered pilot pattern PP2 (SISO)**

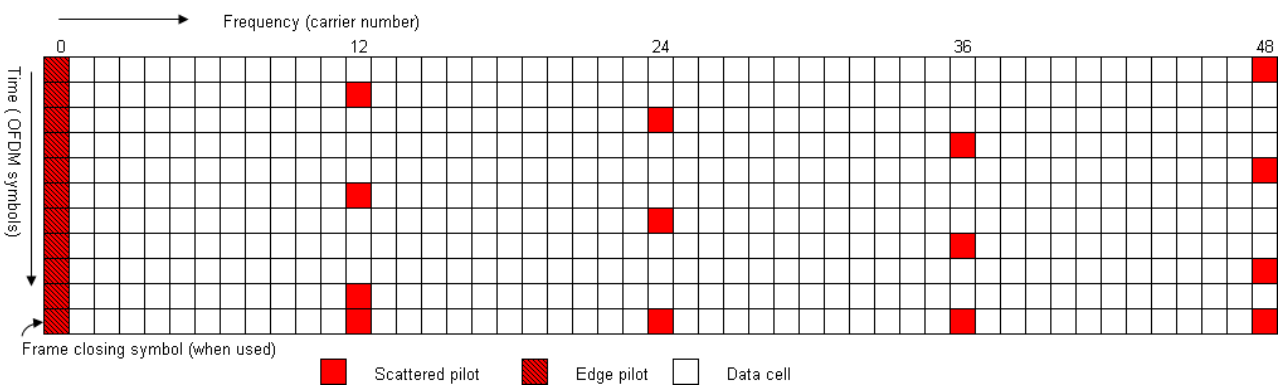




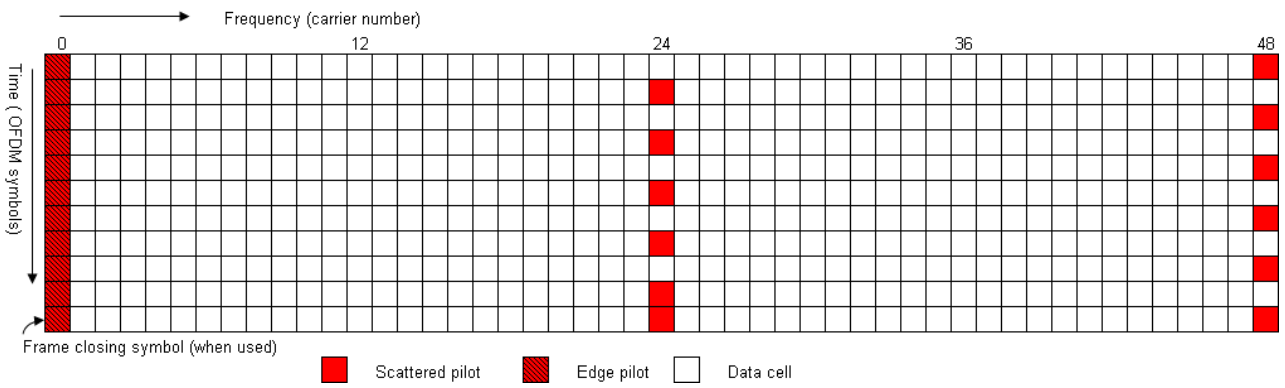
**Figure K.3: Scattered pilot pattern PP3 (SISO)**



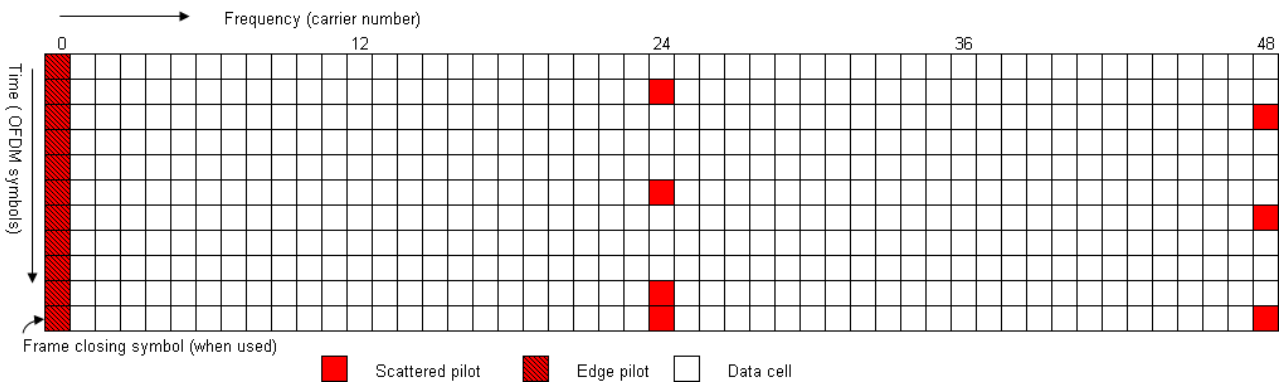
**Figure K.4: Scattered pilot pattern PP4 (SISO)**



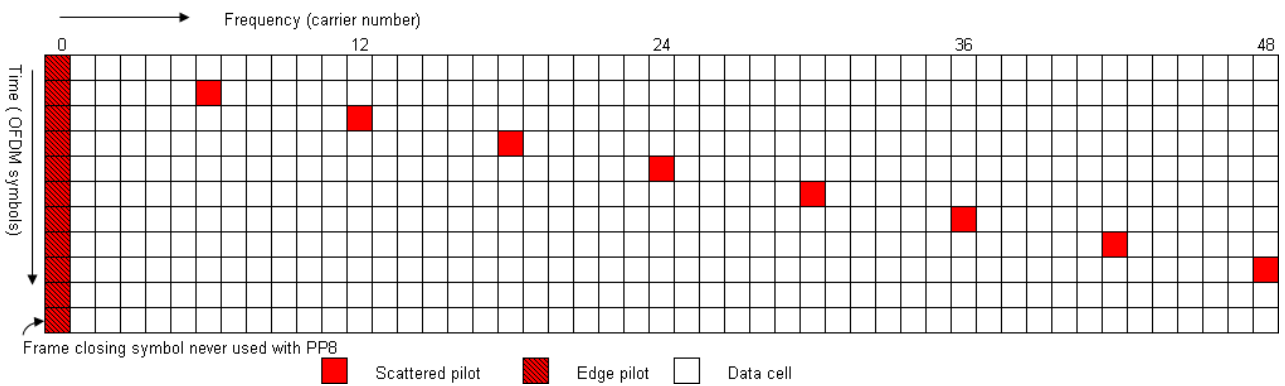
**Figure K.5: Scattered pilot pattern PP5 (SISO)**



**Figure K.6: Scattered pilot pattern PP6 (SISO)**



**Figure K.7: Scattered pilot pattern PP7 (SISO)**



**Figure K.8: Scattered pilot pattern PP8 (SISO)**

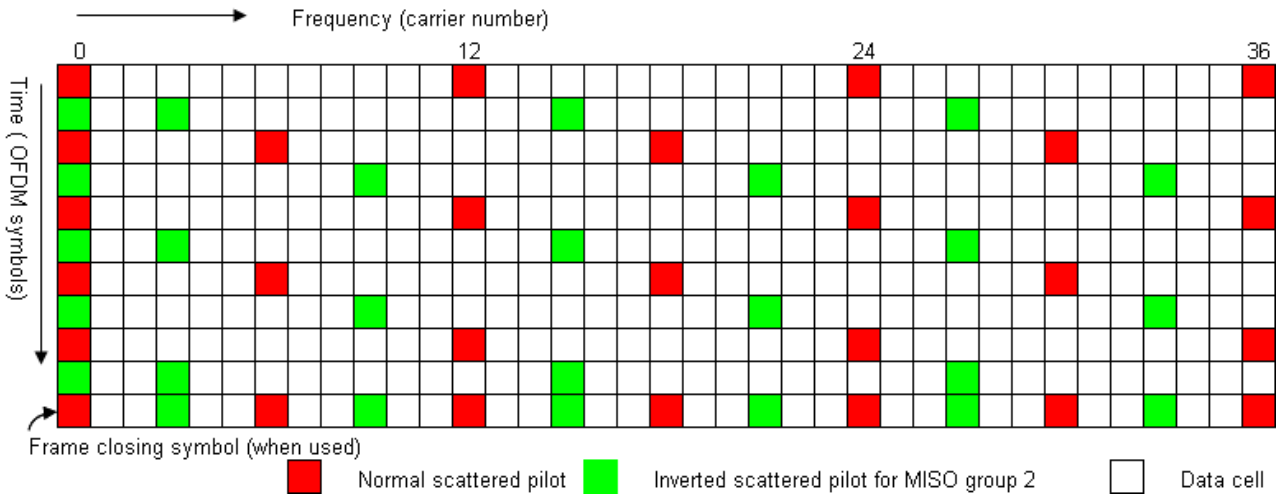


Figure K.9: Scattered pilot pattern PP1 (MISO)

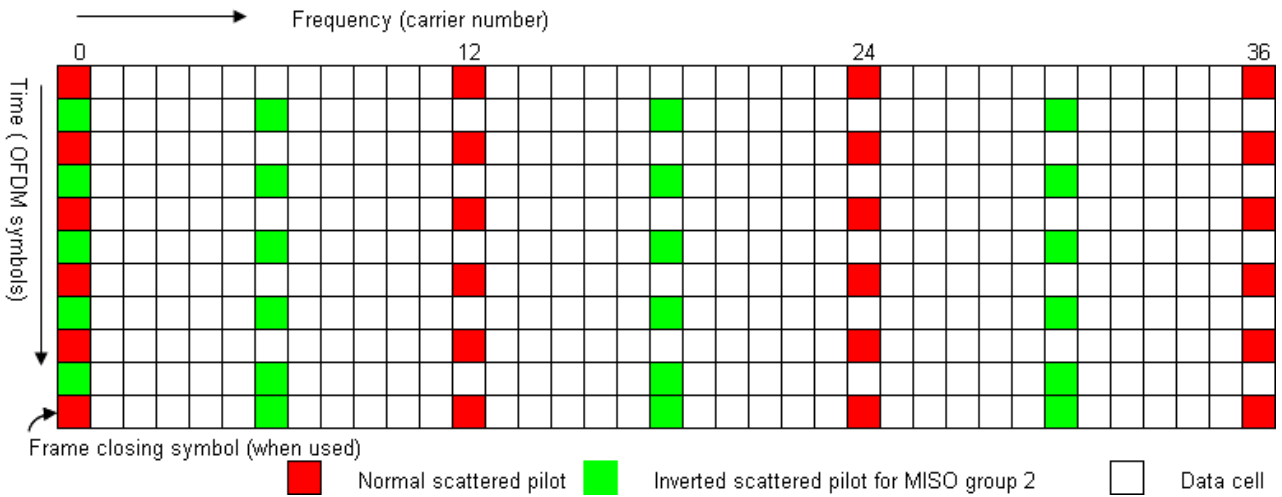


Figure K.10: Scattered pilot pattern PP2 (MISO)

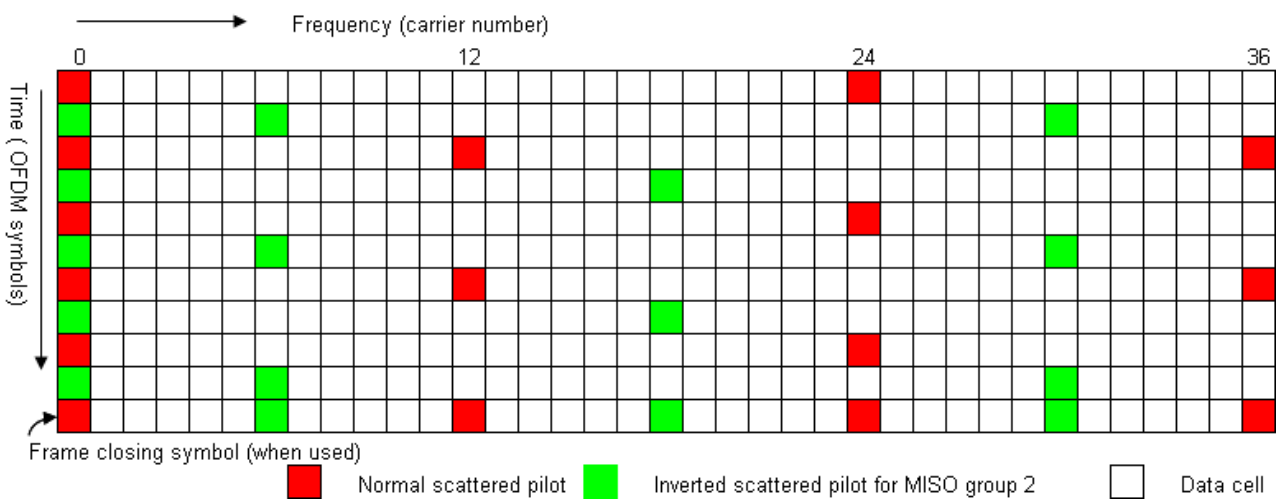
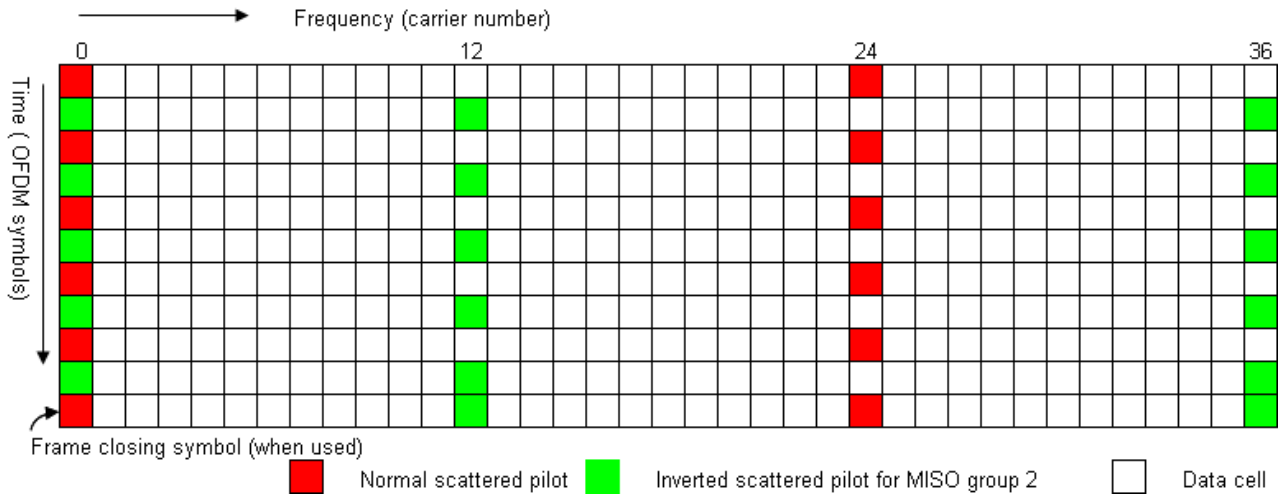
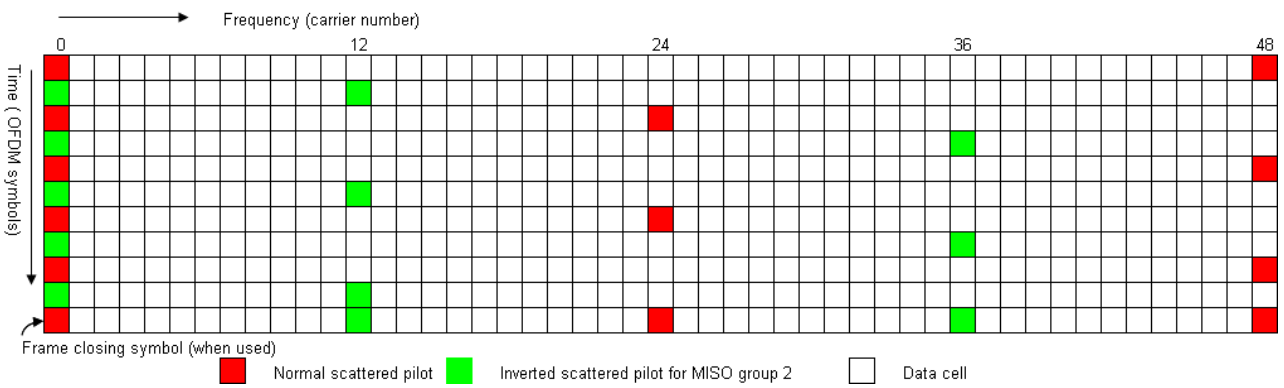


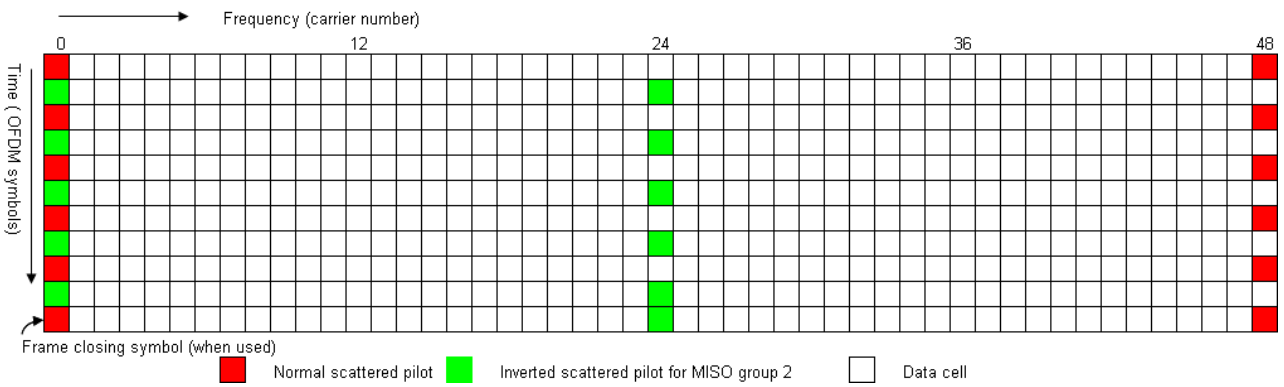
Figure K.11: Scattered pilot pattern PP3 (MISO)



**Figure K.12: Scattered pilot pattern PP4 (MISO)**



**Figure K.13: Scattered pilot pattern PP5 (MISO)**



**Figure K.14: Scattered pilot pattern PP6 (MISO)**

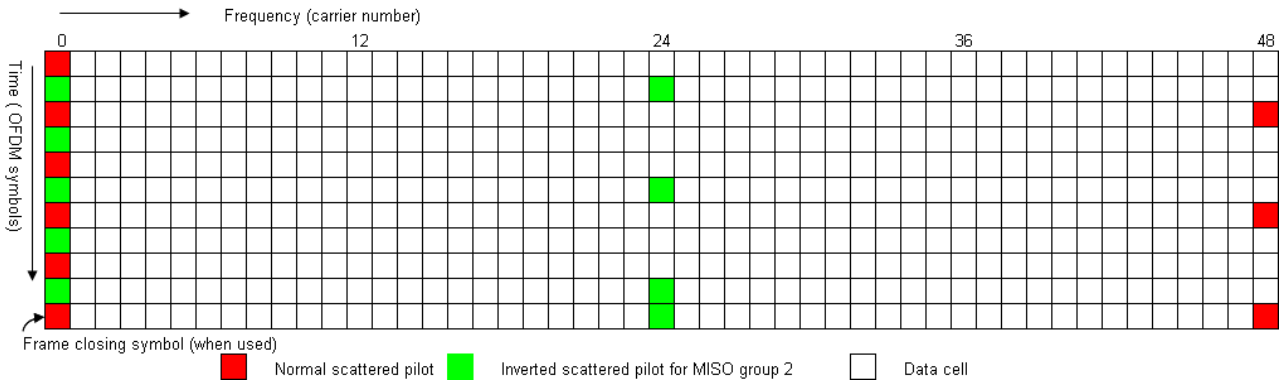


Figure K.15: Scattered pilot pattern PP7 (MISO)

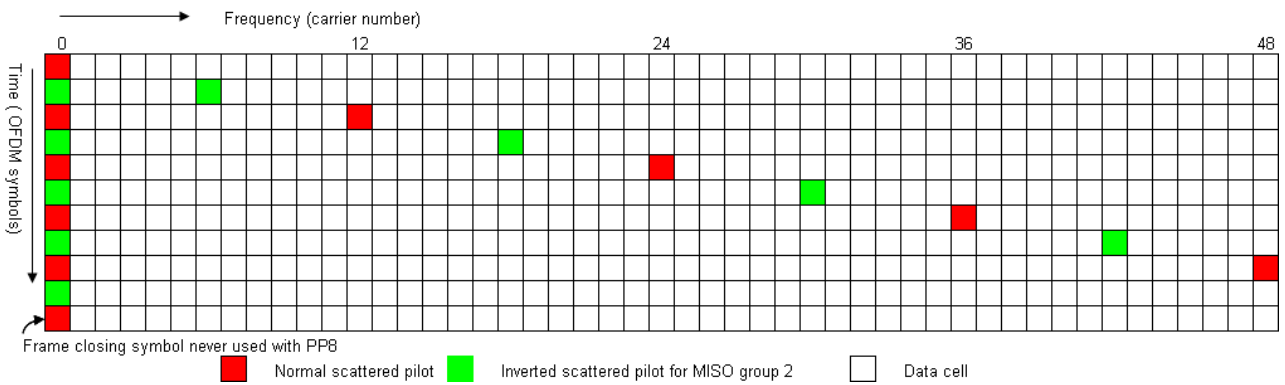


Figure K.16: Scattered pilot pattern PP8 (MISO)

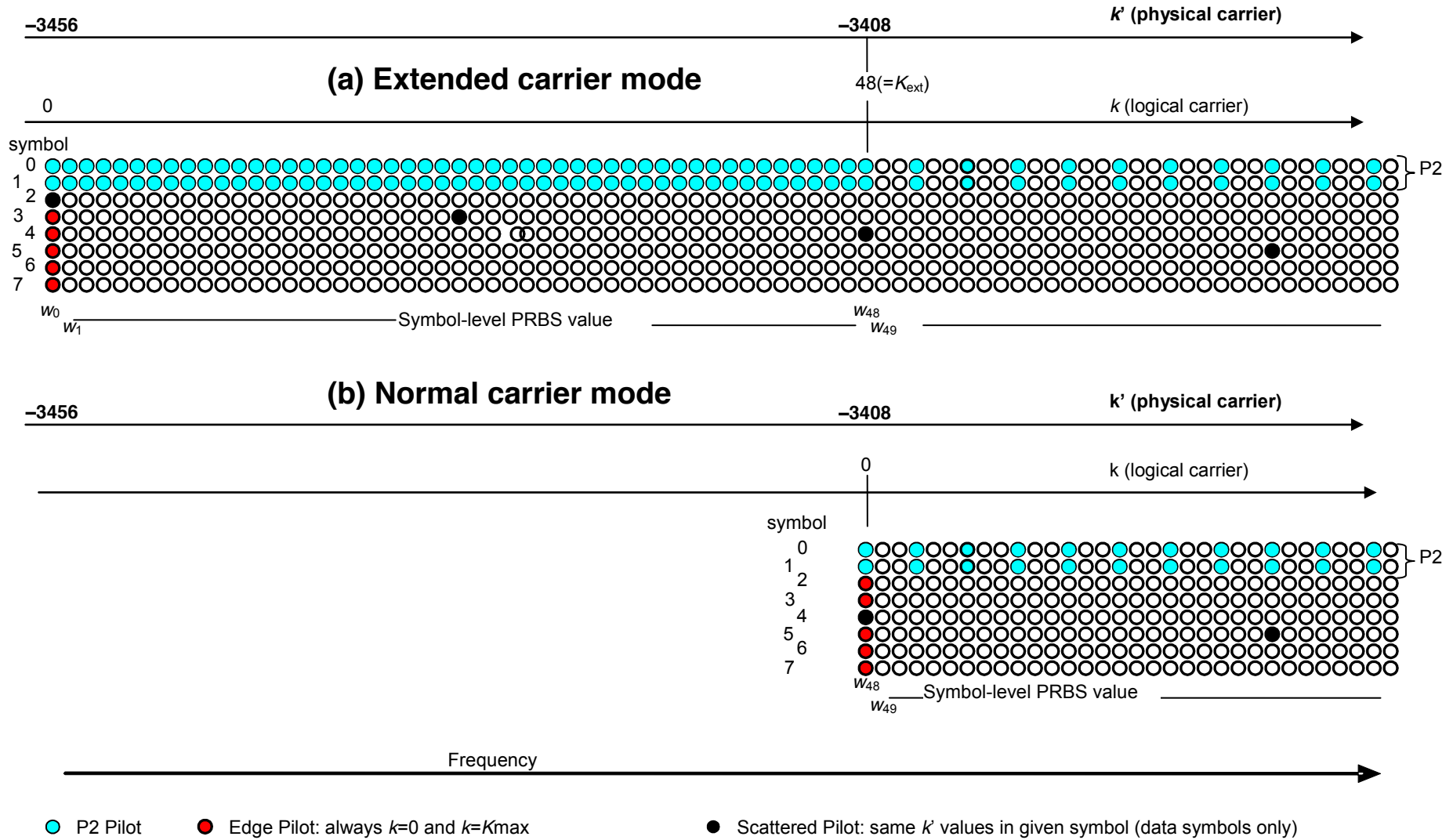


Figure K.17: Example of pilot and TR cells at the edge of the spectrum in extended and normal carrier mode (8K PP7)

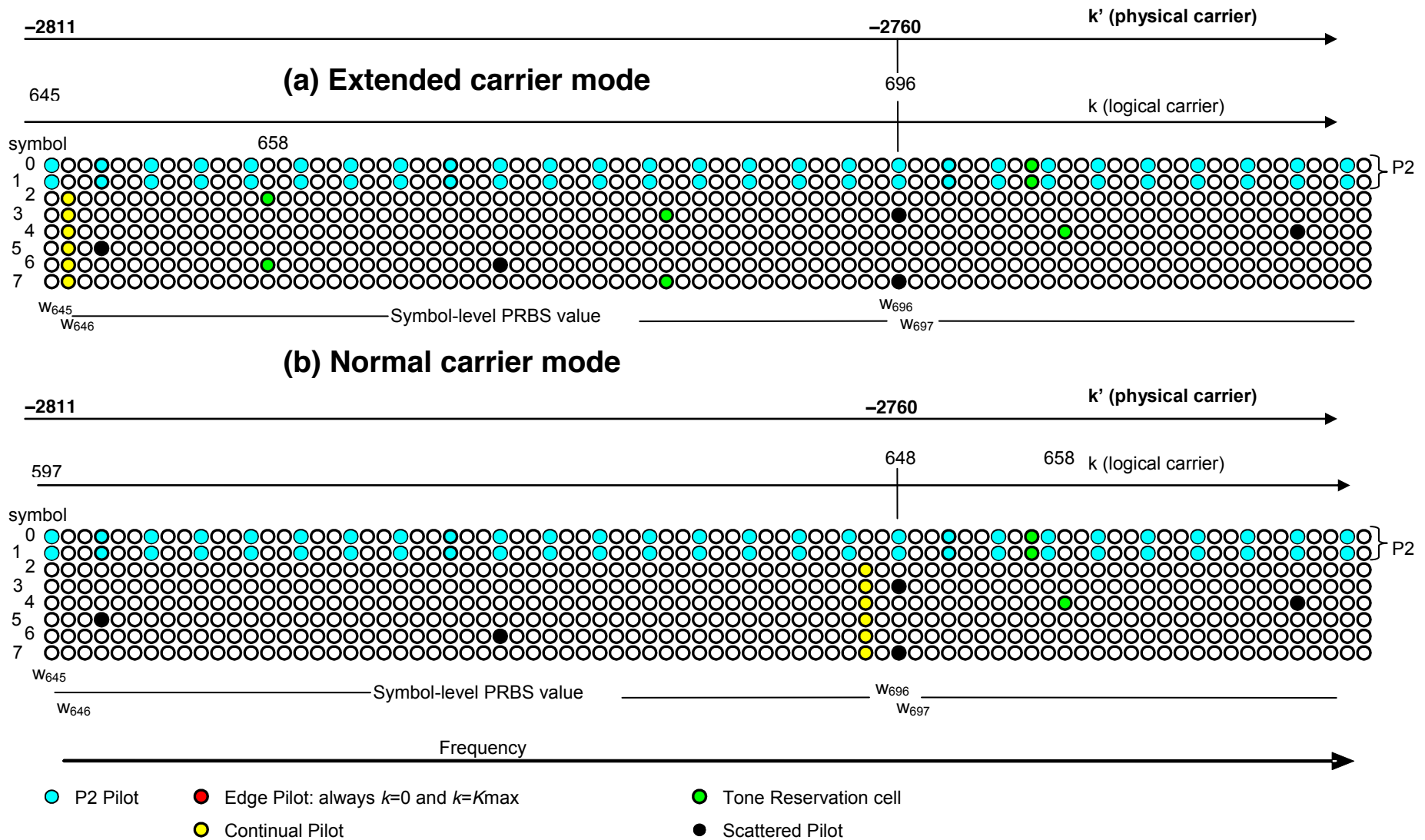


Figure K.18: Example of pilot and TR cells in extended and normal carrier mode (8K PP7)

## Annex L (informative): Allowable sub-slicing values

Table L.1 shows the allowed value for the total number of sub-slices  $N_{\text{subslices\_total}} = N_{RF} \times N_{\text{subslices}}$  (see clauses 6.5.4 and 8.3.6.3.3) at the output of each time interleaver block of each PLP. Since the same value must be used for all PLPs, the value selected from the table must be available for all modulation types and FEC block sizes currently in use. The safest possible options are those from the table of short FEC block sizes with a 'Y' in all four columns, since this will always be suitable for all PLPs. These are listed in the table L.2. If only long FEC blocks are used, values from table L.3 can be used.

**Table L.1: List of available number of sub-slices for different constellations and FEC block sizes**

Long LDPC blocks	Constellation				Short LDPC blocks	Constellation				
	64K	QPSK	16-QAM	64-QAM		256-QAM	16K	QPSK	16-QAM	64-QAM
1	Y	Y	Y	Y	1	Y	Y	Y	Y	Y
2	Y	Y	Y	Y	2	Y	Y	Y	Y	
3	Y	Y	Y	Y	3	Y	Y	Y	Y	
4	Y	Y	Y	Y	4	Y		Y	Y	
5	Y	Y	Y	Y	5	Y	Y	Y	Y	
6	Y	Y	Y	Y	6	Y	Y	Y	Y	
8	Y	Y	Y	Y	9	Y	Y	Y	Y	Y
9	Y	Y	Y	Y	10	Y	Y	Y	Y	
10	Y	Y	Y	Y	12	Y		Y	Y	
12	Y	Y	Y	Y	15	Y	Y	Y	Y	Y
15	Y	Y	Y	Y	18	Y	Y	Y	Y	
16	Y		Y	Y	20	Y		Y	Y	
18	Y	Y	Y	Y	27	Y	Y	Y	Y	Y
20	Y	Y	Y	Y	30	Y	Y	Y	Y	
24	Y	Y	Y	Y	36	Y		Y	Y	
27	Y	Y	Y	Y	45	Y	Y	Y	Y	Y
30	Y	Y	Y	Y	54	Y	Y	Y	Y	
36	Y	Y	Y	Y	60	Y		Y	Y	
40	Y	Y	Y	Y	81	Y	Y			Y
45	Y	Y	Y	Y	90	Y	Y	Y	Y	
48	Y		Y	Y	108	Y		Y	Y	
54	Y	Y	Y	Y	135	Y	Y	Y	Y	Y
60	Y	Y	Y	Y	162	Y	Y			
72	Y	Y	Y	Y	180	Y		Y	Y	
80	Y		Y	Y	270	Y	Y	Y	Y	
81	Y	Y		Y	324	Y				
90	Y	Y	Y	Y	405	Y	Y			Y
108	Y	Y	Y	Y	540	Y		Y	Y	
120	Y	Y	Y	Y	810	Y	Y			
135	Y	Y	Y	Y	1 620	Y				
144	Y		Y	Y						
162	Y	Y		Y						
180	Y	Y	Y	Y						
216	Y	Y	Y	Y						
240	Y		Y	Y						
270	Y	Y	Y	Y						
324	Y	Y		Y						
360	Y	Y	Y	Y						
405	Y	Y		Y						
432	Y		Y	Y						
540	Y	Y	Y	Y						
648	Y	Y		Y						
720	Y		Y	Y						
810	Y	Y		Y						
1 080	Y	Y	Y	Y						
1 296	Y			Y						
1 620	Y	Y		Y						
2 160	Y		Y	Y						
3 240	Y	Y		Y						
6 480	Y			Y						



**Table L.2: List of values for number of sub-slices which may be used with any combination of PLPs (short or long FEC blocks)**

1	3	5	9	15	27	45	135
---	---	---	---	----	----	----	-----

**Table L.3: List of values for number of sub-slices which may be used with any combination of PLPs (long FEC blocks only)**

1	2	3	4	5	6	9	10
12	15	18	20	27	30	36	45
54	60	90	108	135	180	270	540

---

## Annex M (informative): Bibliography

- ETSI TS 102 005: "Digital Video Broadcasting (DVB); Specification for the use of video and audio coding in DVB services delivered directly over IP".
- U. Reimers, A. Morello: "DVB-S2, the second generation standard for satellite broadcasting and unicasting", submitted to International Journal on Satellite Communication Networks, 2004; 22.
- M. Eroz, F.-W. Sun and L.-N. Lee: "DVB-S2 Low Density Parity Check Codes with near Shannon Limit Performance", submitted to International Journal on Satellite Communication Networks, 2004; 22.
- V. Mignone, A. Morello, "CD3-OFDM: a novel demodulation scheme for fixed and mobile receivers", IEEE Transaction on Communications, vol. 44, n. 9, September 1996.
- CENELEC EN 50083-9: "Cable networks for television signals, sound signals and interactive services - Part 9: Interfaces for CATV/SMATV headends and similar professional equipment for DVB/MPEG-2 transport streams".
- S.M. Alamouti, "A Simple Transmit Diversity Technique for Wireless Communications", IEEE Journal on Select Areas in Communications, vol 16, no. 8, October 1998.

---

## History

<b>Document history</b>		
V1.1.1	September 2009	Publication
V1.2.1	October 2010	One-step Approval Procedure      OAP 20110203: 2010-10-06 to 2011-02-03
V1.2.1	February 2011	Publication