

Introduction

Some designers (especially digital designers doing analog design) are intimidated by current feedback amplifiers (CFAs), thus they don't take advantage of the CFA's superior frequency performance. CFAs have become pervasive because they have an architectural advantage that delivers high bandwidth and slew rate at low supply currents. A designer without CFAs in his arsenal is inadequately armed for today's high speed design challenges.

Most of your voltage feedback amplifier (VFA) knowledge is applicable to CFA design because the ideal equations for both amplifiers are identical. The VFA attempts to drive the input error voltage to zero, while the CFA attempts to drive the input error current to zero, so understanding the VFA feedback mechanism simplifies the task of understanding CFA operation. Two characteristics of the CFA will take some getting used to: the closed loop bandwidth is relatively independent of the closed loop gain, and the amplifier's stability is dependent on the feedback resistor value. Both of these differences offer significant advantages for the CFA with very little drawback.

The simplified approach presented here may not be adequate for the more scientifically inclined reader, thus, if a more detailed analysis (including in-depth mathematical derivations) is desired the reader is encouraged to peruse reference [1].

Simplified CFA Model

The simplified CFA model is shown in Figure 1. The external resistors, R_G and R_F , are the gain and feedback elements which determine the gain and bandwidth performance, thus

the object is to determine the proper value for these resistors. When the circuit is configured for non-inverting gain (Figure 1), the input for the circuit is +IN. This terminal connects to a unity gain buffer input, so it has the characteristics of high input impedance and low bias current. Conversely, the -IN input connects to the output of the same buffer. R_B models the output resistance of the buffer, but it is usually a small value which can be ignored. The -IN input has the characteristics of a buffer output which are very low impedance and high current sinking/sourcing capability. The high current capability of the buffer output enables large transient currents to flow through the external circuits, and as will be shown later, this enables higher slew rates for the CFA.

The unity gain input buffer forces -IN to follow +IN unconditionally. During quiescent operation only a small current flows through -IN. This is the error current, I_e , which is analogous to the error voltage of a VFA. The current flowing through -IN is always mirrored (represented by the current source I_e) onto a high impedance node (Z) where it is converted to a voltage via the transimpedance gain of the CFA. Transimpedance gain serves the same function in a CFA that open loop voltage gain serves in a VFA; i.e., it is the driving force which closes the feedback loop. If the amplifier has a large transimpedance gain (Z) it will have a low error current because $I_e = V_{OUT}/Z$. The controlled current source in the simplified model represents the transimpedance element, and when the current flows through the terminating impedance, $R_H \parallel C_H$, a voltage is developed at the input node of the output buffer. The output buffer is another unity gain buffer, and it provides the current capability for driving low impedance loads.

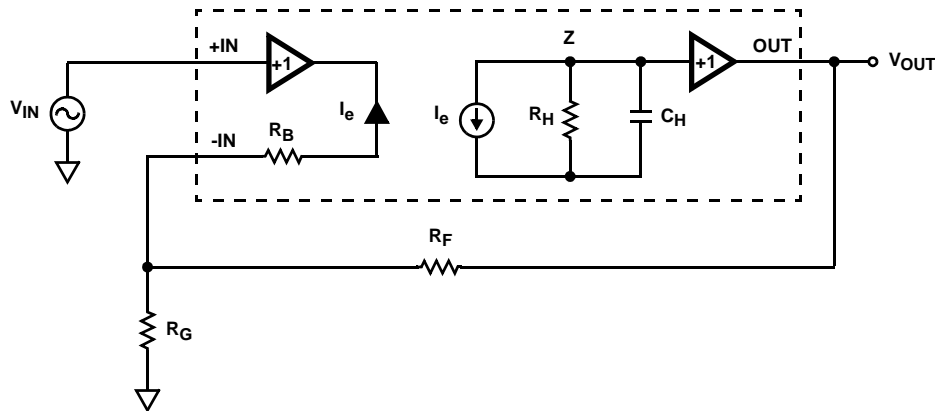

FIGURE 1. THIS SIMPLIFIED MODEL DEMONSTRATES HOW THE CURRENT-FEEDBACK AMPLIFIER (CFA) OPERATES, AND HOW IT DIFFERS FROM THE VOLTAGE-FEEDBACK AMPLIFIER (VFA). THE CONTROLLED CURRENT SOURCE AT NODE Z REPRESENTS THE TRANSIMPEDANCE ELEMENT

For example, consider a voltage follower ($R_G = \text{infinity}$) where at $t = 0$ $V_{+IN} = V_{OUT} = 0$. If at $t = 0+$ a unit step voltage is applied to the input, then at $t = 0+$ $V_{+IN} = V_{-IN} = 1V$, and $V_{OUT} - V_{-IN} = -1V$, thus $I_e = -1V/R_F$. Notice that the slew current, I_e , is dependent on the magnitude of the output voltage change and R_F . This error current is sourced by the input buffer, so an equal current is mirrored onto node Z, causing the voltage to rise, and consequently the output voltage increases. The feedback loop keeps V_{OUT} rising until the error current is driven to the minimum value, and at this point $V_{+IN} = V_{OUT}$ within the error tolerance.

Analyze CFA Amplifiers Just Like VFA Amplifiers

The same four “ideal op amp” assumptions employed to derive the VFA closed loop gain equations are used to derive the ideal CFA closed loop gain equations. By definition, $V_{-IN} = V_{+IN}$ because the element separating the two inputs is a well designed unity gain buffer. The non-inverting input current is low enough to be neglected ($+IN = 0$) because this current is a buffer input current. The inverting input current equals zero ($-IN = 0$) because the feedback loop drives the error current to zero. As long as the transimpedance gain is large the $-IN$ current is negligible. It is prudent to note that the two input currents are totally uncorrelated, thus the common VFA technique of canceling input current errors by balancing the impedance seen at the positive and negative inputs is not recommended for CFAs. The transimpedance gain is extremely high, which enables the feedback loop to function properly just like high open loop gain does in a VFA.

The feedback network is constructed the same for the CFA and VFA; a feedback resistor (R_F) is connected from the op amp output to the inverting input, and a gain setting resistor (R_G) is connected from the inverting input to ground in both cases. Because the feedback network is the same for the CFA and VFA, and because the ideal op amp assumptions are valid for both types, it is obvious that the VFA ideal closed loop gain equation must hold for the CFA.

The non-inverting gain formula, Equation 1, is based on these assumptions; the voltage across R_G is V_{IN} because $-IN$ tracks $+IN$, so the voltage divider rule yields:

$V_{IN} = V_{OUT} R_G / (R_G + R_F)$, or:

$$\frac{V_{OUT}}{V_{IN}} = \frac{R_F + R_G}{R_G} = 1 + \frac{R_F}{R_G} \quad (\text{EQ. 1})$$

When the CFA is used in an inverting gain configuration ($V_{+IN} = V_{-IN} = 0V$) the input current is V_{IN}/R_G (see Figure 2), and the feedback current, which must be equivalent to the input current because no current flows into the op amp inputs, is equal to $-V_{OUT}/R_F$. Equating the currents yields:

$$\frac{V_{OUT}}{V_{IN}} = -\frac{R_F}{R_G} \quad (\text{EQ. 2})$$

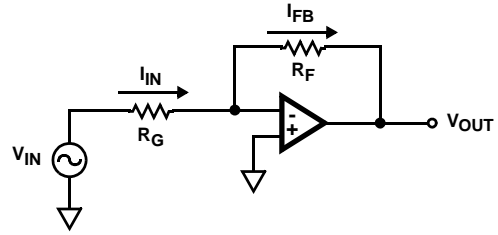

FIGURE 2. THE INVERTING GAIN CONFIGURATION FOR A CURRENT-FEEDBACK AMPLIFIER HAS INPUT AND FEEDBACK RESISTORS JUST LIKE A VFA. THE CIRCUIT'S GAIN EQUATION IS: $(V_{OUT}/V_{IN}) = -(R_F/R_G)$

Frequency Response

The non-ideal gain equation for the non-inverting CFA is taken from Reference 1, Equation 18, and it is repeated here as Equation 3. Notice that the input buffer output resistance, R_B , is designated as Z_B in Equation 3.

$$\frac{V_{OUT}}{V_{IN}} = \frac{Z(1 + Z_F/Z_G)}{Z_F(1 + Z_B/Z_F \parallel Z_G)} \cdot \frac{1}{1 + \frac{Z}{Z_F(1 + Z_B/Z_F \parallel Z_G)}} \quad (\text{EQ. 3})$$

If the input buffer output resistance is zero, which is the goal of every CFA IC designer, Equation 3 reduces to:

$$\frac{V_{OUT}}{V_{IN}} = \frac{Z/Z_F(1 + Z_F/Z_G)}{1 + Z/Z_F} \quad (\text{EQ. 4})$$

The transimpedance gain (Z) contains two or more poles, and these poles make the transfer function frequency dependent. If Z were independent of frequency, and Z_F and Z_G were purely resistive, the CFA would be independent of frequency.

Equation 4 is in the form of the classic closed loop feedback equation $V_{OUT}/V_{IN} = A/(1 + A\beta)$. The sole determining factor for stability in a feedback system is the loop gain, often mathematically expressed as $A\beta$, and the loop gain in Equation 4 is the quantity Z/Z_F [1]. Thus, a fundamental conclusion is that the CFA's stability is completely dependent on the transimpedance and the feedback impedance. This is very different from the VFA where stability is dependent on closed loop gain [1] ($A\beta = a/A_{CL}$). Another important note about the CFA's loop gain is that Z_F being in the denominator precludes Z_F from being zero ohms in a linear circuit. Therefore, a R_F is required even for unity gain applications, and capacitive feedback is undesirable because it will cause Z_F to go to zero at some frequency.

A Bode [2] plot is a log magnitude plot of the gain and phase, and it evaluates stability very effectively. This plot is a transimpedance gain plot for a CFA, where it would be a voltage gain plot for a VFA. The CFA Bode plot for the loop gain of Equation 4 (with the transimpedance plotted as a two-pole transfer function) is given in Figure 3; notice that numerator and denominator of the loop gain are plotted

separately and added graphically to obtain the final result. The criteria for stability is that the loop gain be less than one before -180 degrees of phase shift is accumulated; i.e., $|\beta| < 1$ at $\phi < -180$.

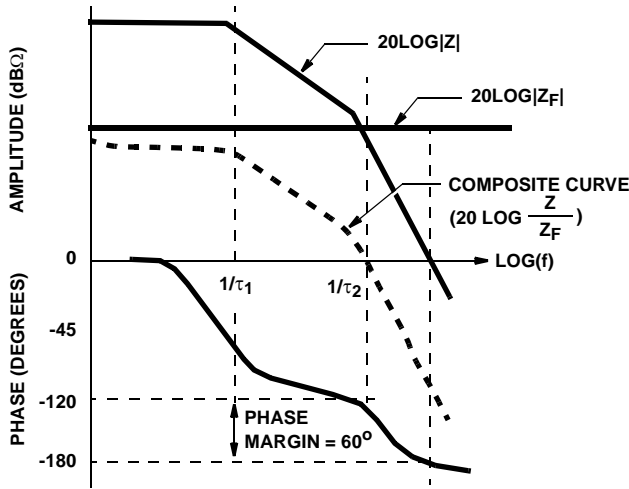

FIGURE 3. THIS BODE PLOT OF A CFA IS USEFUL FOR STABILITY ANALYSIS. WITH A VFA, THE AMPLITUDE SCALE WOULD REPRESENT VOLTAGE GAIN, BUT IN THE CASE OF THE CFA, THE AMPLITUDE SCALE SHOWS THE AMPLIFIER'S TRANSIMPEDANCE GAIN

When the composite curve crosses 0dB ($A\beta = 1$) the phase shift is -120 degrees, so this particular CFA would have 60 degrees of phase margin, and it would be very stable with that value of Z_F . On the Bode plot, $|Z_F| = R_F$ subtracts from the $|Z|$ curve moving the composite curve down from the Z curve, and moving the 0dB gain crossing point to the left into an area of less phase shift. Thus, the conclusion can be made that increasing R_F stabilizes the CFA by reducing the loop gain without impacting the open loop phase shift (i.e., the phase margin has increased, see Figure 4). Note, also from Figure 4, that the amplifier's bandwidth (BW_1 , BW_2) decreases as R_F increases. These are critical conclusions because they indicate that the value of R_F can be adjusted to trade stability for bandwidth, and this is the basis for the conclusion that the CFA bandwidth is inversely proportional to R_F . In actual practice the designer will never decrease R_F so much that the CFA approaches instability, because gain peaking and overshoot increase dramatically long before the circuit becomes unstable. Note, when increasing the closed loop gain of a CFA circuit, R_G should be decreased rather than increasing R_F .

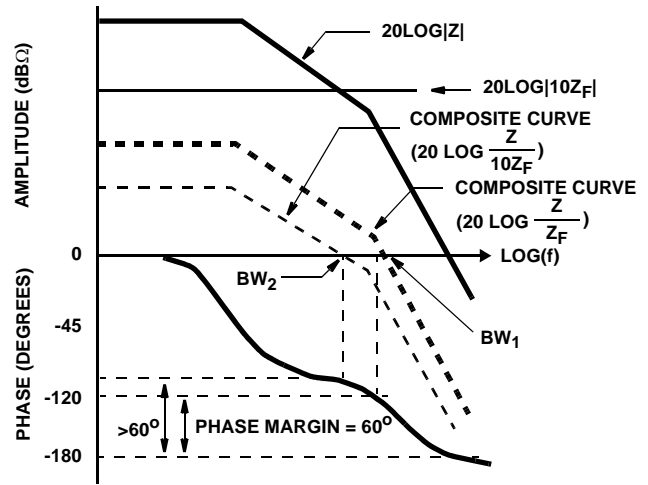

FIGURE 4. BY ADJUSTING THE VALUE OF R_F , THE DESIGNER CAN MAKE A TRADE-OFF BETWEEN STABILITY AND BANDWIDTH. THE BANDWIDTH IS INVERSELY PROPORTIONAL TO R_F

Inspecting Equation 4 reveals that the closed loop gain does not affect stability or the bandwidth of the CFA because it does not impact the loop gain nor the pole-zero locations. This means that the CFA bandwidth is independent of closed loop gain, except for the minor effect of the neglected Z_B term (see Equation 3). When Z_B is taken into consideration, the CFA bandwidth becomes slightly dependent on closed loop gain, but it is still much more independent of closed loop gain than the VFA is. This phenomenon explains why CFAs make much better high frequency, high gain amplifiers than VFAs do. Z_B is usually an emitter-follower type output impedance which exhibits a zero in the transfer function at high frequencies. This explains why CFAs tend to become peaky at high frequencies especially when there is significant capacitance on the inverting input.

Slew Rate And Pulse Performance

Slew rate is a measure of the amplifier's ability to transition from one output voltage to another in response to an input voltage change. Fast slew rates are required for good pulse amplifiers because pulses contain fast rise and fall times.

The error current is multiplied by the transimpedance gain to form the unbuffered output voltage, so the sooner the error current is driven to zero the faster the amplifier gets to its final output voltage. An earlier derivation established the formula for the unity gain CFA error current as $I_e = (V_{OUT} - V_{IN})/R_F$. Thus, if R_F is decreased or ΔV_{IN} is increased, more current is available to slew the internal high impedance node and faster slew rates result. If the input step size is doubled in a CFA the current available for slewing is doubled, hence the rise/fall time is virtually independent of step size. The VFA has an internal current source which limits the maximum slew rate regardless of the voltage step size. The usual method of increasing slew rate in a VFA is for the op amp manufacturer to increase this internal current source which also increases supply current.

The input buffer must first slew to follow the input signal, so the input buffer's slew rate is a critical part of the overall slew rate. In high gain configurations the input buffer does not go through a large voltage change compared to the output, so its slew rate does not contribute much error. In low gain configurations the input buffer can significantly degrade the slew rate. For example: in unity gain applications the CFA's input buffer must slew the inverting input the same amount as the output, and this often limits the unity gain CFA's slew rate. In inverting gain configurations $-IN$ is a virtual ground so the input buffer doesn't have to slew much, so the inverting gain configuration has the fastest slew rate.

How To Convert From VFAs to CFAs

The CFA can usually replace the VFA in most high frequency applications with better performance and lower cost [3]. There are a few salient points to be aware of during the replacement, and most cases will require either minor or no PC board changes. But remember that the CFA must **always** have a feedback resistor. It can't be substituted directly for a VFA in unity gain applications where the output is shorted to the inverting input ($R_F = 0$).

The key to CFA stability is the feedback resistor. While higher R_F values are fine for VFAs, most CFAs are optimized for $R_F < 1k\Omega$, and higher than optimum values degrade CFA performance dramatically. A value of R_F that yields stable operation can always be found. It is best to start with the manufacturer's recommended value, but graphical techniques [3] can be used to select new R_F values if wider bandwidth or a higher closed loop gain (reduce R_G rather than increase R_F) is desired. Remember, reducing R_F increases bandwidth while increasing ringing and overshoot. Don't drop the value of R_F too much or oscillation will result. Other common factors that destabilize CFAs when replacing VFAs are excessive capacitance on the inverting input or the output. A common source of ringing or oscillation in any high frequency amplifier is a long PC board trace length attached to the inverting input lead; this situation is exacerbated with a CFA.

Circuit configurations using feedback capacitors or diodes do not lend themselves to CFAs because these feedback components will approach zero impedance at some operating point and oscillation will result. Diodes in the feedback loop can often be replaced by input or output clamp diodes. Feedback capacitors can be neutralized by putting a resistor equal to the optimum value of R_F in series with them. The classic inverting integrator cannot be implemented in a CFA, so the non-inverting integrator is often used in its place. Basically speaking, the CFA is no harder to use than the VFA with equivalent bandwidth; it's just a little different.

References

For Intersil documents available on the internet, see web site <http://www.intersil.com>

- [1] AN9420 Application Note, Intersil, "Current Feedback Amplifier Theory and Applications"
- [2] Bode H. W., "Network Analysis And Feedback Amplifier Design", D. VanNostrand Inc., 1945
- [3] AN9663 Application Note, Intersil, "Converting From Voltage-Feedback To Current-Feedback Amplifiers"

All Intersil U.S. products are manufactured, assembled and tested utilizing ISO9000 quality systems. Intersil Corporation's quality certifications can be viewed at www.intersil.com/design/quality

Intersil products are sold by description only. Intersil Corporation reserves the right to make changes in circuit design, software and/or specifications at any time without notice. Accordingly, the reader is cautioned to verify that data sheets are current before placing orders. Information furnished by Intersil is believed to be accurate and reliable. However, no responsibility is assumed by Intersil or its subsidiaries for its use; nor for any infringements of patents or other rights of third parties which may result from its use. No license is granted by implication or otherwise under any patent or patent rights of Intersil or its subsidiaries.

For information regarding Intersil Corporation and its products, see www.intersil.com