



FÉDÉRATION INTERNATIONALE
DE MOTOCYCLISME

**ROAD RACING FIM SIDECAR
WORLD CHAMPIONSHIP REGULATIONS**

2011

*RÈGLEMENTS DU CHAMPIONNAT DU MONDE
FIM DE SIDECAR DE COURSES SUR ROUTE*



**Road Racing FIM Sidecar World
Championship
Regulations**

**Règlements du Championnat du Monde
FIM de Sidecar de courses sur route**



2011

FEDERATION INTERNATIONALE DE MOTOCYCLISME (FIM)

11, route Suisse

CH - 1295 MIES

SUISSE

Tel: +41-22-950 950 0

Fax: +41-22-950 950 1

www.fim-live.com

paul.duparc@fim.ch

jean-paul.gombeaud@fim.ch

CONTENTS / SOMMAIRE

1.	Sporting Road Racing FIM Sidecar World Championship Regulations	1 - 47
	<i>Règlements Sportifs du Championnat du Monde FIM de Sidecar de Courses sur Route</i>	<i>1 - 47</i>
2.	Technical Regulations for FIM Sidecar World Championship	48 - 84
	<i>Règlements Techniques du Championnat du Monde FIM de Sidecar de Courses sur Route</i>	<i>48 - 84</i>

Articles amended as from 1.1.2011 are in bold type
Les articles modifiés dès le 1.1.2011 sont en caractères gras

ROAD RACING FIM SIDECAR WORLD CHAMPIONSHIP REGULATIONS

1	SPORTING REGULATIONS	7
1.1	Introduction	7
1.2	Events	7
1.3	The paddock	8
1.4	Officials	9
1.5	International Jury	11
1.6	The calendar	12
1.7	Machines	12
1.8	Eligible competitors	12
1.9	Schedule	15
1.10	Technical control – medical control – doping control	15
1.11	Practice	16
1.12	Change of passenger	17
1.13	Starting grid	17
1.14	Races	18
1.15	Start procedure	18
1.16	Ride through procedure	22
1.17	Wet and dry races	23
1.18	Behaviour during practice and race	24
1.19	Flags and lights	26

1.20	Medical cars.....	30
1.21	Finish of a race and race results.....	30
1.22	Interruption of a race.....	32
1.23	Re-starting a race that has been interrupted	33
1.24	Check area	34
1.25	Podium	34
1.26	Final technical control.....	35
1.27	Deposits in case of machine control following a protest ..	35
1.28	Deposit for fuel controls following a protest.....	35
1.29	Sanction for non-compliance with the fuel rules	35
1.30	Championship points and classification	36
1.31	Instructions and communications to competitors	37
2	TECHNICAL REGULATIONS	48
2.1	Introduction	48
2.2	Technical specifications of chassis, Eligibility requirements.....	48
2.3	Technical specifications of engine, Engine installation, eligibility requirements	57
2.4	Diagram A of chassis.....	63
2.10	Fuel, fuel sampling and testing.....	64
2.11	Protective clothing and helmets	68

2.12	Procedure of technical control.....	69
2.13	Verification guidelines for technical stewards.....	71
2.14	Sound, sound control.....	76
2.15	Guidelines for use of sound level meters	77
3.	DISCIPLINARY AND ARBITRATION CODE	79
4.	CIRCUIT STANDARDS	80
5.	MEDICAL CODE.....	81
6.	ANTI-DOPING CODE.....	82
7.	ENVIRONMENTAL CODE	83
	Diagrams and appendices	84

General Undertakings and Conditions

IN THE CURRENT REGULATIONS, THE WORD “RIDER” ALSO MEANS “PASSENGER”.

All riders, teams' personnel, officials, organisers and all the persons involved in any capacity whatsoever participating in the Road Racing FIM Sidecar World Championship (hereinafter referred to “Championship”) undertake, on behalf of themselves, their employees, and agents, to observe all the provisions of:

1. SPORTING REGULATIONS
2. TECHNICAL REGULATIONS
3. DISCIPLINARY AND ARBITRATION CODE
4. CIRCUIT STANDARDS
5. MEDICAL CODE
6. ANTIDOPING CODE
7. ENVIRONMENTAL CODE

as supplemented and amended from time to time.

All the persons mentioned above may be penalised in accordance with the provisions of the Road Racing FIM Sidecar World Championship Regulations (hereinafter referred to “Regulations”).

Whilst the Regulations may be translated into other languages, in case of any dispute regarding interpretation the Official English text will prevail.

It is the responsibility of the team to ensure that all persons concerned with its entry observe all the requirements of the Regulations. The responsibility of the rider, or any other person having charge of an entered machine during any part of the Event with respect to observance of the Regulations is joint and several with that of the team.

All persons concerned in any way with an entered machine or present in any capacity whatsoever in the Paddock, Pits, Pit lane or Track, shall wear an appropriate pass at all times during the Event.

ANTIDOPING CODE

All the persons concerned shall at all times observe the FIM Anti-Doping Code and may be penalised accordingly.

SUPPLEMENTARY REGULATIONS

In special circumstances, the FIM may allow the organiser of individual event to mention in the Supplementary Regulations particular provisions not included in or different from the current Regulations.

1. SPORTING REGULATIONS

1.1 INTRODUCTION

1.1.1 A series of races counting toward the FIM Sidecar World Championship for riders will be organised.

1.1.2 Official documents relating to a meeting shall conform to article 100.5 of the FIM Sporting Code.

1.2 EVENTS

1.2.1 The Event shall be deemed to commence at the scheduled time for Technical and Sporting Checks and finish after all the races at the expiry of the deadline for the lodging of a protest and the time at which technical or sporting verifications have been concluded, whichever is the latest.

The race control shall remain operative with all equipment in place until the end of the period provided for the lodging of a protest, and all officials and marshals shall remain at the circuit available to the International Jury during that period.

1.2.2 Events shall be staged on race circuits that have been approved by the FIM for the Championship.

1.2.3 Events shall not include any other races except for support races approved by **the FIM** which may not alter the event schedule (1.11).

1.2.4 Any activity involving 4 wheels racing vehicular use of the track during the event, including "demonstrations", displays or the suchlike shall receive prior approval from **FIM**.

1.2.5 Organisers will be nominated by **the FIM**.

1.2.6 The Organiser is responsible for providing the facilities and personnel to ensure the smooth and efficient running of the event.

1.2.7 The organiser shall obtain insurance for third party liability according to article 110.1.2 of the FIM Sporting Code.

1.2.8

At least 90 days prior to the Event, the Organisers of the event shall submit the following information to **the FIM**:

- a – Confirmation of the name and address of the Organisers, including telephone and facsimile numbers for correspondence.
- b – The date and place of the Event.
- c – A detailed plan of the circuit, its direction, clockwise or anticlockwise, and length.
- d – The location at the circuit of the teams and riders information centre and the official notice board.
- e – The name and address of the company providing the third party liability insurance cover and the number of the policy.
- f – Name and address of FMNR.
- g – The name of the Clerk of the Course (with FIM Clerk of the course licence).
- h – The name, address and telephone number of the Chief Medical Officer.
- i – The name, address and telephone number of the hospitals designated for the event.
- j – The Supplementary Regulations for the event in English and French (see appendix).

1.3

THE PADDOCK

1.3.1

The Paddock, pit boxes and all other facilities shall be available to teams at least on the day prior to the first practice day and remain available to competitors for at least one day after the event.

1.3.2

Access shall be available for teams arriving to set up between the hours of 08:00 and 20:30.

1.3.3 At all times that the Paddock is occupied there shall be a basic medical service and fire fighting service in the circuit.

A fire truck shall be provided with the following minimum characteristics: tank capacity 4 cubic meters; pressure: 40 kg/cm² (high), 12 kg/cm² (low); water rate 300 - 400 litres/minute.

1.4 OFFICIALS

1.4.1 All the following officials shall be present and available at the time necessary to ensure smooth and efficient running of the Event.

1.4.2 Refer to article 40 of the FIM Sporting Code.

1.4.3 The following officials will be appointed for individual events to perform supervisory and executive roles.

A) Officials appointed by the FIM

1) The President and two members of the International Jury (with FIM Sporting Steward licence). They are responsible for ensuring that the event is conducted according to the Regulations.

The International Jury President is responsible for the supervision of all aspects of safety

2) The FIM Technical Director;
Responsible for ensuring that technical Regulations are correctly enforced and supervising scrutineering and protests of a technical nature.

B) Officials appointed by the FMNR/Organiser.

3) Clerk of the Course; responsible for:

a – Ensuring that the circuit is suitably prepared for and maintained during the Event and that all legal requirements applicable for the running of the event have been complied with.

- b – Ensuring that all officials and services are in place.

The stationing of all track personnel and equipment (i.e. marshals, doctors, ambulances, flags, etc.) alongside the Circuit no later than 30 minutes prior to the beginning of all practice sessions and warm up.

The Jury President, the Clerk of the Course and the Chief Medical Officer will make the final inspection of the Circuit to ensure this regulation is complied with, 30 minutes prior to the beginning of the all practice sessions and warm up.

During the final inspection lap, the yellow flag shall be waved at each flag marshal post together with the display of other flags and equipment requested by the Jury President.

- c – Taking decisions to ensure the smooth and efficient running of the event.
- d – Ensuring that the event is run within the Regulations.
- e – Notification of protests to the International Jury.
- f – The control of practice and the race, adherence to the timetable and, if he deems it necessary, the making of any proposal to the International Jury to modify the timetable in accordance with the Sporting Regulations.
- g – The stopping of practice or the race in accordance with the Sporting Regulations if he deems it unsafe to continue and ensuring that the correct restart procedure is carried out.
- h – The starting procedure.
- i – The use of safety cars/fast interventions vehicles.
- j – Immediate approval and signature with time of provisional results (practices, warm-ups, starting grids and races) and presentation of reports to the International Jury.

- 5) Secretaries ;
Responsible for:
- a – During the event effecting communications between the various officials.
 - b – Providing secretarial support for the International Jury.
- 6) Other Officials ;
- The Chief Technical Steward shall be holder of the FIM Technical Steward licence.

1.4.4 All communications between Officials appointed by the FMNR/ Organiser shall be made via the relevant FIM Officials.

1.5 INTERNATIONAL JURY

1.5.1 Refer to article 50.1 of the FIM Sporting Code.

1.5.2 The International Jury will meet at any time required during the event, but at least:

- a – Prior to the first practice session.
- b – At the end of each practice day.
- c – At the end of the event.

1.5.3 The duties of the International Jury are:

- a – To amend the Supplementary Regulations if necessary.
- b – To take decision as provided in the Regulations.
- c – To ensure the smooth and efficient running of the event.
- d – To receive reports from the various Officials concerning scrutineering, practice and races.
- e – To confirm the practices and races results.

- f – To make recommendations to the organiser to improve the smooth and efficient running of the event.
- g – To impose penalties for any infringements of the Regulations occurring during the event.
- h – To impose penalties on organisers for having been unable to ensure the smooth and efficient running of the event or for serious breaches of the Regulations.
- i – To adjudicate on any protest relating to infringements of the Regulations occurring during the event.

No protest and no appeal to the CAS may be lodged against a decision of the International Jury entailing or not:

- a ride through
- a disqualification from the practice sessions or races by means of a black flag or black flag with orange disc.
- a fine for speeding in the pit lane.

No protest and no appeal to the CAS may be lodged against a decision of the International Jury based on a photo finish.

1.6 THE CALENDAR

- 1.6.1** The calendar of races counting for the Championship will be, in principle, published by no later than 31st October of the preceding year.

1.7 MACHINES

1.7.1 Means of propulsion

A machine shall only be propelled by its own motive power, the muscular effort of its rider and by the natural forces of gravity.

1.8 ELIGIBLE COMPETITORS

1.8.1 Licences

The riders shall be in possession of the adequate FIM Sidecar World Championship Licence issued by a FMN. Licences are issued to riders designated and can, in certain circumstances, be for a single event. To receive a licence, the rider shall be in possession of a national licence of a FMN at no additional cost to the rider.

Licenses are issued only when the minimum age has been attained as below:

- Driver : 18 years
- Passenger: 16 years

The limit for the minimum age starts on the date of the rider's birthday.

The limit for the maximum age finishes at the end of the year in which the rider reaches the age of 60.

1.8.2 Entries

All entries shall be made in writing on an entry form on which all information regarding the rider, teams, sponsor and make of the machine shall be indicated.

The entry form shall be printed in the official languages of the FIM and shall mention Art. 60.5 of the Sporting Code.

Riders shall have a permission to take part in the event delivered by their FMN.

Entries shall be received one month in advance, but, in the case of "force majeure", may be modified up until the scrutineering.

A compulsory briefing for all riders who are participating for the first time in the current Championship will be organised before the beginning of the 1st official practice session.

Failure to attend the briefing in full will result in the disqualification of the rider.

The licenses of the riders will be checked.

A waiver may be granted by the Jury President.

1.8.3 Contracted riders

1.8.3.1 30 days before each event, the FIM will publish a list of contracted riders. This list may be updated until the day preceding the 1st session of the official practice.

1.8.3.2 Each contracted rider commits himself to compete in all the remaining events. Exception may only be made as follows:

A rider may withdraw from additional events for medical reasons only or other reasons of "Force Majeure".
Withdrawal shall be approved by the FIM.

1.8.4 Acceptance

The entries shall be made according to the following priority:

- Before the 1st event of the Championship:
 - The riders under contract;
 - The riders having obtained points in the Championship of the previous year;
 - Other riders.

- After the 1st event of the Championship:
 - The riders under contract;
 - The riders having obtained points in the Championship of the current year at the closing date of entries;
 - Other riders.

1.8.5 Non-participation in an event

Any rider who enters an event shall inform the organiser if, subsequently, he decides not to participate in the event. A rider who has submitted an entry form and fails to participate will be reported by the International Jury to the FIM, who will impose the following penalties:

- First offence: fine of 150 €.

- Subsequent offences in the same season: Suspension from the next event counting towards the Championship.

Upon receipt of the International Jury's report, the Executive Secretariat will send a letter to the rider's FMN asking the reasons for the non-participation; a reply should be sent within 15 days at the latest and a decision will be taken regarding the penalty.

An exclusion could also be pronounced against a rider who takes part in another event on the same day.

1.8.6 Withdrawal from an event

A rider may withdraw from an event which has already started, due to injury, irreparable damage to the motorcycle(s) or in case of "Force Majeure". Withdrawal shall be approved by the International Jury.

1.8.7 Participation in an event

A rider shall be deemed to have taken part in the event when he participates in, at least, one practice session.

1.8.8 Participation in the race

A rider shall be deemed to have started a race when he participates in, at least, the first lap of the race.

1.9 SCHEDULE

FRIDAY and SATURDAY: ARRIVAL AND SETTING UP OF TEAMS

SATURDAY

TECHNICAL AND SPORTING CHECKS

FREE PRACTICE	20 to 40 minutes
Interval	60 minutes
QUALIFYING PRACTICE	20 minutes
Interval	30 minutes
QUALIFYING PRACTICE	20 minutes

SUNDAY

GOLD Race	minimum 70 km maximum 85 km
SPRINT RACE (option)	minimum 35 km maximum 45 km

All the riders and teams shall be immediately and in writing informed of any schedule change.

The above schedules may only be varied as follows:

- i) Prior to the event by the **FIM**;
- ii) During the event by the International Jury.

1.10 TECHNICAL CONTROL–MEDICAL CONTROL– DOPING CONTROL

1.10.1 All machines should be checked by the Technical Stewards prior to first participation in practice on safety aspects, according to the published schedule.

Teams may present more than one machine for Technical Control which will be specially identified by the Technical Controllers.

Unless a waiver is granted by the International Jury, Teams who do not comply with the schedule for technical or medical controls will not be allowed to take part in the event.

1.10.2 The procedure for Technical Control is described in the Technical Regulations, articles 2.12 and 2.13.

The procedure for Medical Control is described in the FIM Medical Code.

1.10.3 Any rider to be tested for doping control shall report to the doping control room in the Medical Centre with sufficient identification within one hour of notification.

One associate may accompany the rider.

1.11 PRACTICE

1.11.1 Practice Sessions (warm-up inclusive)

- i) Riders will commence practice from the pit lane when the green light is displayed at the exit of the pit lane.
- ii) The duration of practice will commence from the illumination of the green light. A visible board or count-down will be shown in the pit lane to indicate the minutes of practice remaining.
- iii) The end of practice will be indicated by the waving of a chequered flag at which time the pit exit will be closed. A rider's time will continue to be recorded until he passes the finish line after the allotted time has elapsed. After the chequered flag riders may complete one additional lap prior to entering the pits.

- iv) If practice is interrupted due to an incident or any other reason, then a red flag will be displayed at the start line and at all marshals posts. All riders shall return slowly to the pit lane. When practice is restarted, the time remaining will be that shown on the count-down device in the pit lane and on the monitors of the official timekeepers at the moment the red flags were displayed.
- v) Riders or mechanics may only start their machines in the pit lane by pushing in the direction of the circuit.
- vi) After practice has started, the conditions of the racing surface of the circuit should not be altered except on instruction from the International Jury President and the Clerk of the Course in response to a localised change in conditions.

1.11.2 Lap time

All laps of the riders will be timed.

1.11.3 Qualifying practices results

The results will be based on the fastest time recorded by the riders in all qualifying practices.

In the case where all qualifying practices have been cancelled, the results will be based on the fastest time recorded by the riders in all free practice sessions. In the event of a tie, riders' second and subsequent best times will be taken into account.

1.11.4 Qualification for the race

To qualify for the race, a rider shall achieve a time at least equal to 115% of the time recorded by the fastest rider in at least one qualifying session.

Any rider who fails to achieve a qualifying time will be permitted to take part in the race provided that in any of the free practice sessions he/she has achieved a time at least equal to 115% of the fastest rider in same session.

Such riders will start the race from the back of the grid, in order of their free practice times.

1.12 CHANGE OF PASSENGER

During practice, it is possible to change the passenger only once; This change shall be immediately notified to the International Jury President who in turn will inform the timekeeping service.

A change of passenger with another driver is only possible if the driver agrees. The time made with the 2nd passenger will be valid for the qualification. The sidecar driver may run the race, if he is qualified, only with the 2nd passenger.

1.13 STARTING GRID

1.13.1 Grid positions will be based on the qualifying practice results or according to article 1.9.1.

1.13.2 At the International Jury meeting on the day proceeding the race day, a provisional starting grid will be established.

1.13.3 The Grid will be arranged in 3-2-3-2-3 configuration "in echelon". Each line will be offset. There will be a distance of 9 metres between each row.

1.13.4 The pole position, allocated to the faster rider, will be determined during the homologation of the circuit.

1.13.5 The final grid will be published at the latest one hour before the start of the race.

1.14 RACES

1.14.1 Distance

The length of races shall be according to Art. 1.9 and will be determined by **the FIM** after publication of the calendar.

1.14.2 The length of a race may only be varied by the International Jury.

1.14.3 A visible countdown board will be shown at the finish line to indicate the number of remaining laps in the race.

- 1.14.4** If the Timekeeping rooms are fed by normal power (electricity) supply, they shall also be permanently connected to an U.P.S. (Uninterruptible Power System) and to a generator.

1.15 START PROCEDURE

- 1) Approximately 15 Minutes (10 minutes in the case of a restarted race) before the Start of the Race - Pit lane exit opens for sighting lap.

Count-down boards of 5, 4, 3, 2 and 1 minute are shown at the pit exit.

- 2) Approximately 10 Minutes (5 minutes in the case of a restarted race) before the Start of the Race - Pit lane exit closes.

- 3) The sighting lap is not compulsory. Riders who do not take part in the sighting lap may, under the supervision of an official, push their machine on to the grid up until, at the latest 5 minutes before the start of the warm up lap.

- 4) Riders who do not go on to the grid may start the warm up lap from the pit lane under the instructions of the marshal positioned at the pit lane exit. Such riders may not change wheels after the display of the 3 minute board.

- 5) When the riders reach the grid after the sighting lap they shall take up their positions and may be attended by up to six persons, two of whom may hold an umbrella. All attendants on the grid shall wear a "Grid Pass". Having taken up their grid position, the riders shall take off their helmets, except in the case of a restarted or wet race.

Officials will display panels, at the side of the track, indicating the row of the grid, to assist riders in locating their grid position.

- 6) The Clerk of the Course may, at this stage, choose to declare the race as "wet" or "dry" and will indicate this to the riders on the grid and those who may still be in the pit lane by the display of a board. If no board is displayed the race will automatically be "dry".

- 7) Riders who encounter a technical problem on the sighting lap may return to the pit lane to make adjustments or to change machines. In this instance the rider shall start the warm up lap from the pit lane.

- 8) Riders on the grid may, at this stage, make adjustments to the machine or change tyres to suit the track conditions.

All adjustments shall be completed by the display of the 3 minute board. After this board is displayed, riders who still wish to make adjustments shall push their machine to the pit lane. Such riders and their machines shall be clear of the grid and in the pit lane before the display of the 1 minute board, where they may continue to make adjustments or change machine. Such riders will start the warm up lap from the pit lane.

- 9) Refuelling or changing fuel tank on the grid is forbidden.
- 10) 5 Minutes Before the Start of the Warm Up Lap - Display of 5 Minute Board on the grid.
- 11) 3 Minutes Before the Start of the Warm Up Lap - Display of 3 Minute Board on the grid.

At this point, all persons except the one holding the umbrella, the television crew of the host broadcaster and essential officials shall leave the grid.

Riders shall put their helmets on.

No person (except essential officials) is allowed to go on the grid at this point.

- 12) 1 Minute Before the Start of the Warm Up Lap - Display of 1 Minute Board on the grid.
At this point, all persons will leave the grid.
- 13) 30 Seconds Before the Start of the Warm Up Lap - Display of 30 Second Board on the grid.

All riders shall be in position on the grid with engines running. No further assistance from mechanics is permitted. Any rider who is unable to start his machine shall remove it to the pit lane, under the control of the grid marshals, where he may make further attempts to start it or change machine. Such riders may start the warm up lap from the pit lane.

- 14) 2 Minutes Before the Start of the Race – Green flag waved to start the warm up lap.

In the interest of safety, should a rider stall his machine, he may be assisted to restart. If, after a reasonable period, the engine does not start, then the rider will be pushed into the pit lane where his mechanics may provide assistance or where the rider may change machine.

The riders will make one lap, at unrestricted speed, followed by a safety car. The safety car will overtake slow riders.

As soon as the riders have passed the pit lane exit, the pit lane exit light will be turned green, and any rider waiting in the pit lane will be permitted to join the warm up lap. Thirty seconds later, the light will turn red and a marshal will display a red flag closing the pit lane exit.

On returning to the grid the riders shall take up their positions with the front wheel of their motorcycle up to or behind the front line and between the side lines defining the grid position and keep their engines running. An official will stand at the front of the grid holding a red flag.

Any rider who the safety car has taken up his position at the back of the grid will be directed into the pits and may start the race from there or he shall stop beside the safety car and start the race from there, as directed by a marshal.

Any rider who encounters a problem with his machine on the warm up lap may return to the pit lane and make repairs or change machine.

Any rider who stalls his engine on the grid or who has other difficulties shall remain on the motorcycle and raise an arm. It is not permitted to attempt to delay the start by any other means.

As each row of the grid is completed, the officials will lower the panels indicating that their row is complete. Panels will not be lowered when a rider in that row has indicated that he has stalled his motorcycle or has other difficulties. When all panels have been lowered and the safety car has taken up its position, an official at the rear of the grid will wave a green flag.

The Starter will then instruct the official at the front of the grid, displaying the red flag, to walk to the side of the track.

- 15) A red light will be displayed for between 2 and 5 seconds. The red light will go out to start the race.

A safety car will follow behind the motorcycles for the whole of the first lap. The safety car will overtake slow riders.

If the red lights' device is fed by normal power (electricity) supply, it shall also be connected to a set of car batteries or to an U.P.S. (Uninterruptible Power System) to provide power to the starting lights' device if the electric line breaks down just at the moment of the start.

Any rider who anticipates the start will be required to carry out the ride through Procedure described under article 1.16.

Anticipation of the start is defined by the motorcycle moving forward when the red lights are on. The International Jury will decide if a penalty will be imposed and shall arrange for the team to be notified of such penalty before the end of the fourth lap.

- 16) If, after the start of the race, a rider stalls his machine, then he may be assisted by being pushed along the track until the engine starts. If, after a reasonable period, the engine does not start, then the rider will be pushed into the pit lane where his mechanics may provide assistance or where the rider may change machine.
- 17) After the riders have passed the exit of the pit lane, the official situated at this exit will display a green light to start any riders still in the pit lane.
- 18) After the leading rider has passed the finish line at the end of his first lap, no further changes of machines are permitted unless the race is interrupted.
- 19) Should there be a problem that might prejudice safety, then the Starter will display a flashing yellow light and the board "Start Delayed" and a marshal will wave a yellow flag at each row of the starting grid from the signalling platform. In this instance, riders shall stop their engine. The start procedure will be re-commenced at the 1 minute board stage, the riders will complete an additional warm up lap and the race distance will be reduced by one lap. Any person who, due to his behaviour on the grid is responsible for a "start delayed", may be penalised with one of the following penalties: fine – ride through - disqualification - withdrawal of Championship points.

1.16 RIDE THROUGH PROCEDURE

During the race, the rider will be requested to ride through the pit lane. Stopping is not permitted.

He may then rejoin the race.

The rider shall respect the speed limit (Art. 1.18.14) in the pit lane. In case of infraction of this speed limit, the ride through procedure will be repeated; in case of a second infraction of this speed limit, the black flag will be shown to the rider.

In the event of a restarted race, the above regulation will also apply.

In the case of a race interrupted prior to the penalty being complied with, and if there is a second part, the rider will be required to ride through after the start of the second part of the race.

In the case of a rider carrying forward a penalty for anticipation of the start, into the second part of an interrupted race and subsequently found to have anticipated the second start, the rider will be shown the black flag.

After notification has been made to the Team, a yellow board (100cm horizontal X 80 cm vertical) displaying the rider's number (black colour, height 50cm, stroke width 10cm) will be shown at the finish line and the information will also be displayed on the time keeping monitors.

Failure by the relevant rider to ride through, having been shown the board 5 times, will result in that rider being shown the black flag.

If more than one rider is penalised, the riders will be signalled to ride through on subsequent laps. The order of the riders will be based on the qualifying times with the faster rider first.

In the case of a rider failing to respond to the instruction to ride through, and there being more than one rider penalised, no subsequent riders will be signalled to ride through until the previous rider has completed the ride through procedure or has been shown the black flag.

In the case where the organisation has been unable to carry out the ride through penalty before the end of the race, the relevant rider will be inflicted with a time penalty of 20 seconds.

1.17 “WET” AND “DRY” RACES

- 1.17.1** All races will be categorised as either wet or dry. A board may be displayed on the grid to indicate the status of the race. If no board is displayed, the race is automatically dry. The purpose of this classification is to indicate to riders the consequence of varying climatic conditions during a race.
- 1.17.2** Dry Races - A race classified as dry will be interrupted by the Clerk of the Course, if he considers that climatic conditions affecting the surface of the track makes it likely that riders will wish to change tyres.
- 1.17.3** Wet Races - A race classified as wet, usually commenced in varying or wet conditions, will not be stopped for climatic reasons and riders who wish to change tyres or make adjustments shall enter the pits and do so during the actual race.
- 1.17.4** In all cases where the first race is stopped for climatic reasons, then the restart will, automatically, be a “wet” race.

1.18 BEHAVIOUR DURING PRACTICE AND RACE

- 1) Riders shall obey the flag signals, the light signals, and the boards which convey instructions. Any infringement to this rule will be penalised according to the provisions of article 1.19.
- 2) Riders shall ride in a responsible manner which does not cause danger to other competitors or participants, either on the track or in the pit-lane. Any infringement of this rule will be penalised with one of the following penalties: time penalty - fine – ride through - disqualification - withdrawal of Championship points - suspension.

- 3) Riders should use only the track and the pit-lane. However, if a rider accidentally leaves the track then he may rejoin it at the place indicated by the **officials** or at a place which does not provide an advantage to him. Any infringement of this rule during the practices or warm up will be penalised by the cancellation of the lap time concerned and during the race, by a ride through.
Further penalties (such as fine – disqualification - withdrawal of Championship points) may also be imposed
- 4) Any repairs or adjustments along the race track shall be made by the rider working alone with absolutely no outside assistance. The marshals may assist the rider to the extent of helping him to lift the machine and holding it whilst any repairs or adjustments are made. The marshal may then assist him to re-start the machine.
- 5) If the rider intends to retire, then he shall park his motorcycle in a safe area as indicated by the marshals.
- 6) If the rider encounters a problem with the machine which will result in his retirement from the practice or the race, then he should not attempt to tour at reduced speed to the pits but should pull off the track and park his machine in a safe place as indicated by the marshals.
- 7) Riders who are returning slowly to the pits for remedial work should ensure that they travel as far as possible off the racing line.
- 8) Riders may enter the pits during the race. Refuelling and changing motorcycle are strictly prohibited.
- 9) Riders who stop their engines in the pits may be assisted to re-start their motorcycle by the mechanics.
- 10) Riders are not allowed to transport another person on their machine or to be transported by another rider on his machine (exception: Another rider or by another rider after the chequered flag or the red flag).
- 11) Riders shall not ride or push their motorcycles in the opposite direction of the circuit, either on the track or in the pit lane, unless doing so under the direction of an Official.

- 12) No signal of any kind may pass between a moving machine and the rider's team, or anyone connected with the machine's team entrant or rider, except for the signals of the timekeeping transponder, lap trigger, GPS, legible messages on a pit board, or body movements by the rider or team. Onboard TV camera signals are allowed, but only when such signals are for the purposes of and managed by **the FIM or the Championship local organiser**.

- 13) Riders in the top ten positions may be required to carry up to two "on-bike" cameras on their machine.

The cameras and associated equipment shall be carried during all practice sessions and the race.

Where it is impractical to supply cameras and associated equipment for every motorcycle being used by the rider in practice or racing, then the company designated for the supply of the equipment will provide dummy equipment of equivalent weight, size and mounting location to the functioning equipment.

Cameras and other equipment, functioning or dummy, will be supplied to the designated Teams by, at the latest, two hours before the first practice at an event.

Teams shall give reasonable access and assistance to the company designated for the supply of the camera equipment to facilitate the mounting of the equipment.

- 14) A speed limit of 60 km/h will be enforced in the pit lane at all times during the event. Riders shall respect the speed limit from where the sign 60 km/h is placed up to where the sign 60 km/h crossed out is placed.

Any rider found to have exceeded the pit lane speed limit during the practice will be subject to a fine of 150 €.

Any rider who exceeds the pit lane speed limit during a race will be penalised with a ride through.

The International Jury shall communicate the offence to the pit of the rider after having received the information from the Official in charge.

- 15) Stopping on the track during practices and races is forbidden.

- 16) During the practice sessions and warm ups, practice starts are permitted, when it is safe to do so, at the pit lane exit before joining the track and after passing the chequered flag at the end of practice sessions and warm ups, when it is safe to do so, off the racing line.
- 17) If the winning rider wishes to parade a flag, he shall ride to the side of the racing surface to collect the flag and then rejoin the circuit when it is safe to do so.
- 18) After the chequered flag, riders riding on the track must wear a safety helmet until they stop on the pit lane / parc fermé.
- 19) It is not permitted to ride racing motorcycles within the circuit other than in the pit lane or on the track.
- 20) Any rider whose machine spill oil on the track causing interruption of practice, warm up or race twice in the same event will be penalised with one of the following penalties: fine - disqualification - withdrawal of Championship points - suspension.
- 21) Riders must wear the FIM logo.

1.19 FLAGS AND LIGHTS

Marshals and other officials display flags or lights to provide information and/or convey instructions to the riders:

1.19.1 Flags and Lights Used to Provide Information:

- **Green Flag**

The track is clear

This flag shall be shown motionless at each flag marshal post for the first lap of each practice session and of the warm up, for the sighting lap and for the warm up lap.

This flag shall be shown motionless at the flag marshal post immediately after the incident that necessitated the use of one or more yellow flags.

This flag shall be waved by the starter to signal the start of the warm up lap. When the pit-lane exit is open, this flag shall be waved at the pit-lane exit.

- **Yellow and Red Striped Flag**
The adhesion on this section of the track could be affected by any reason other than rain.
This flag shall be shown motionless at the flag marshal post.
- **White Flag with diagonal red cross**
Drops of rain on this section of the track.
This flag shall be shown motionless at the flag marshal post.
- **White Flag with diagonal red cross + Yellow and Red Striped Flag**
Rain on this section of the track.
These flags shall be shown together motionless at the flag marshal post.
- **Blue Flag**
Shown waved at the flag marshal post, this flag indicates to a rider that he is about to be overtaken.
During the practice sessions, the rider concerned shall keep his line and slow down gradually to allow the faster rider to pass him.
During the race, the rider concerned is about to be lapped. He shall allow the following rider(s) to pass him at the earliest opportunity.
Any infringement of this rule will be penalised with one of the following penalties: fine - disqualification - withdrawal of Championship points.
At all times, this flag will be shown waved to a rider leaving the pit lane if traffic is approaching on the track.
- **Chequered Black / White Flag**
This flag will be waved at the finish line on track level to indicate the finish of race or practice session.
- **Chequered Black / White Flag and Blue Flag**
The chequered black/white flag will be waved together with the blue flag presented motionless at the finish line on track level when a rider(s) precedes closely the leader during the final lap before the finish line (see art. 1.21.1).
- **Green Light**
This light shall be switched on at the pit lane exit to signal the start of each practice session and of the warm up, the start of the sighting lap and the start of the warm up lap.

- **Flashing Blue Lights**
Will be switched on at the pit lane exit at all time during practices and races.

1.19.2 **Flags Which Convey Information and Instructions:**

- **Yellow Flag**
Shown waved at each row of the starting grid, this flag indicates that the start of the race is delayed.

Shown waved at the flag marshal post, this flag indicates that there is a danger ahead. The riders shall slow down and be prepared to stop. Overtaking is forbidden up until the point where the green flag is shown.

- Any infringement of this rule during a practice session will result in the cancellation of the time of the lap during which the infraction occurred.
- Any infringement of this rule during the race will be penalised with a ride through.
- In both cases, further penalties (such as fine - suspension) may also be imposed.
- If immediately after having overtaken, the rider realise that he did an infraction, he shall raise his hand and let pass the rider(s) that he has overtaken. In this case, no penalty will be imposed.

During the final inspection lap, this flag shall be waved at the exact place where the flag marshal will be positioned during the practices, the warm ups and races.

- **Red Flag and Red Lights**
When the race or practice is being interrupted, the red flag will be waved at each flag marshal post and the red lights around the track will be switched on. Riders shall return slowly to the pits.

When the pit-lane exit is closed, this flag will be shown motionless at the pit-lane exit and the light will be switched on. Riders are not allowed to exit the pit lane.

Any infringement of this rule will be penalised with one of the following penalties: fine - disqualification - withdrawal of Championship points - suspension.

The red flag will be shown motionless on the starting grid at the end of the sighting lap and at the end of the warm up lap.

The red flag may also be used to close the track.

The red lights will be switched on at the start line for between 2 and 5 seconds to start each race.

- **Black Flag**

This flag is used to convey instructions to one rider only and is displayed motionless at each flag marshal post together with the rider's number. The rider shall stop at the pits at the end of the current lap and cannot restart. This flag will be presented only after the rider's team has been notified. Any infringement of this rule will be penalised with one of the following penalties: fine - withdrawal of Championship points - suspension.

- **Black Flag with orange disk (Ø 40 cm)**

This flag is used to convey instructions to one rider only and is displayed motionless at each flag marshal post together with the rider's number. This flag informs the rider that his motorcycle has mechanical problems likely to endanger himself or others, and that he shall immediately leave the track. Any infringement of this rule will be penalised with one of the following penalties: fine - withdrawal of Championship points - suspension.

1.19.3 Flag Dimension

The flag dimension should be 80 cm in the vertical and 100 cm in the horizontal.

The flag dimension will be checked the day preceding the day of the first practice session.

1.19.4 Flag Colour

The Pantones for the colours are as follows :

Orange :	Pantone 151C
Black :	Pantone Black C
Blue :	Pantone 286C or 298C
Red :	Pantone 186C
Yellow :	Pantone Yellow C
Green :	Pantone 348C

The flags' colours will be checked the day preceding the day of the first practice session.

1.19.5 Rider' s number board

Black board (70 cm horizontal X 50 cm vertical) which enables the race number of a rider to be attached with a set of numbers in white, whose stroke width is minimum 4 cm and height minimum 30 cm.

This board shall be available at each flag marshal post.

1.19.6 Flags Marshals posts

The location will be fixed during the circuit homologation.

1.19.7 Marshals Uniforms

It is strongly recommended the marshals' uniforms to be in white or orange (Ref. Pantone: 151C) and the rain coat to be transparent.

1.20 MEDICAL CARS

The medical cars, if they are to go on to the track, shall be equipped with yellow flashing lights. The words "MEDICAL CAR" should be clearly indicated on the back and the sides of the car.

1.21 FINISH OF A RACE AND RACE RESULTS

1.21.1 When the leading rider has completed the designated number of laps for the race, he will be shown a chequered flag by an official standing at the finish line at track level. The chequered flag will continue to be displayed to the subsequent riders.

When the chequered flag is shown to the leading rider, no other rider will be permitted to enter the track from the pit lane.

As soon as the chequered flag is shown to the leading rider, the red light will be switched on at the pit lane exit and a marshal showing a red flag will stand in the pit lane exit.

If a rider(s) closely precedes the leader during the final lap before the finish line, the official will show to the rider(s) and to the leader simultaneously the Chequered flag and the Blue flag. That means that the race is finished for the leader while the rider(s) closely preceding the leader has (have) to complete the final lap and take the Chequered flag.

1.21.2 In case of a photo-finish between two, or more, riders, the decision shall be taken in favour of the competitor whose machine leading edge crosses the plane of the finish line first. In case of ties, the riders concerned will be ranked in the order of the best lap time made during the race.

- 1.21.3** The results will be based on the order in which the riders cross the line and the number of laps completed.
- 1.21.4** To be counted as a finisher in the race and be included in the results a rider shall:
- a – Complete 75% of the race distance.
 - b – Cross the finish line on the race track (not in the pit lane) within five minutes of the race winner. The rider shall be in contact with his machine.

1.21.5 The classification including the FIM **and** FMNR logos, will mention, at least, the following information:

- The names of the riders and passengers;
- The performance carried out (laps, time);

It is compulsory for the Jury President to send a list of fines and results by fax or email immediately after the approval of results to the FIM Executive Secretariat.

1.21.6 A new lap record for a circuit may only be established by a rider during a race.

1.21.7 Both for practice and for race, the lap time is the subtraction of the time between two consecutive crossings of the finish line painted on the track.

1.22 ***INTERRUPTION OF A RACE***

1.22.1 If the Clerk of the Course decides to interrupt a race due to climatic conditions or some other reason, then red flags will be displayed at the finish line and at all flag marshals' posts and he will switch on the red lights around the circuit. Riders shall immediately slow down and return to the pit lane.

The results will be the results taken at the last point where the leader and all other riders on the same lap as the leader had completed a full lap without the red flag being displayed calculated as in the principle set out in the following example:

Example of a race consisting of 30 laps:

If a Red Flag is shown when the leader is on his 10th lap after completing his 9th lap and all other sidecars have not completed the 9th lap, then the race result will be 8 laps completed, and the second part will consist of 22 laps.

If a Red Flag is shown when the leader and all other sidecars on the same lap as the leader are on the 10th lap after completing the 9th lap, the race result will be 9 laps completed and the second part will consist of 21 laps.

Exception: if the race is interrupted after the chequered flag, the following procedure will apply:

- 1) For all the riders to whom the chequered flag was shown before the interruption, a partial classification will be established at the end of the last lap of the race.
- 2) For all the riders to whom the chequered flag was not shown before the interruption, a partial classification will be established at the end of the penultimate lap of the race.
- 3) The complete classification will be established by combining both partial classifications as per the principle of the lap/time.

At the time the red flag is displayed, riders who are not actively competing in the race will not be classified.

Within 5 minutes after the red flag has been displayed, riders who have not entered the pit lane, riding on their machine, will not be classified.

1.22.2

If the results calculated show that less than three laps have been completed by the leader of the race and by all other riders on the same lap as the leader, then the race will be null and void and a completely new race will be run. If it is found impossible to re-start the race, then it will be declared cancelled and the race will not count for the Championship.

1.22.3 If three laps or more have been completed by the leader of the race and all other riders on the same lap as the leader, but less than two-thirds of the original race distance, rounded down to the nearest whole number of laps, then the race will be re-started according to article 1.23.4. If it is found impossible to re-start the race, then the results will count and only half points will be awarded for the Championship.

1.22.4 If the results calculated show that two-thirds of the original race distance rounded down to the nearest whole number of laps have been completed by the leader of the race and by all other riders on the same lap as the leader, then the race may be deemed to have been completed and full points will be awarded for the Championship or the race may be restarted.

1.23 RE-STARTING A RACE THAT HAS BEEN INTERRUPTED

1.23.1 If a race has to be re-started, then it will be done as quickly as possible, consistent with track conditions allowing. As soon as the riders have returned to the pits, the Clerk of the Course will announce a time for the new start procedure to begin which, conditions permitting should not be later than 20 minutes after the initial display of the red flag.

1.23.2 The intermediary placings shall be available to teams before the following part of a race may be started.

1.23.3 The start procedure will be identical to a normal start with a sighting lap, warm up lap, etc.

1.23.4 Conditions for the re-started race will be as follows:

- i) In the case of a situation as described in 1.22.2 above (less than 3 laps completed):
 - a. All riders may re-start.
 - b. Machines may be repaired or changed. Refuelling is permitted.
 - c. The number of laps will be the same as the original race distance.
 - d. The grid positions will be as for the original race.
- ii) In the case of a situation as described in 1.22.3 (3 laps or more and less than two-thirds completed) above:
 - a. Only riders who are on the intermediary placings may re-start.
 - b. Machines may be repaired or changed. Refuelling is permitted.
 - c. The number of laps of the second race will be the number of laps required to complete the original race distance.
 - d. The grid position will be based on the order of the intermediary placing.
 - e. The final result of the race will be based on the results of each rider classified in each race added together. Riders who have completed an identical number of laps will be placed according to the combined time.

1.24 CHECK AREA

With the exception of Jury members, the Clerk of the Course and officials who are in charge of keeping watch over the closed park area, no-one may at any time or for any reason be admitted into this area unless they have a written and signed authorisation from the Clerk of the Course.

After the end of the race, all the machines which have finished the race shall remain at the disposal of the officials, for 30 minutes, in the closed park. They cannot be removed without the approval of the Jury.

1.25 PODIUM

The riders placed in the first three positions in the race will be escorted by officials, as quickly as possible, to the podium for the awards ceremony.

Participation in the podium ceremony by the first three riders is compulsory.

1.26 FINAL TECHNICAL CONTROL

At the end of each race, a technical control with dismantling may be carried out on the first 3 machines and other machines chosen by random by the President of the International Jury and the FIM Technical Director.

1.27 DEPOSITS IN CASE OF MACHINE CONTROL FOLLOWING A PROTEST

The deposit in case of dismantling and reassembling a machine to measure the cylinder capacity, following a protest, is 150 € (material included).

The deposit in case of partial or complete dismantling of an engine or gearbox is 300 €.-

If the party who makes the protest is the losing party, the deposit shall be paid to the winning party. If the party who makes the protest is the winning party, the deposit shall be reimbursed.

1.28 DEPOSIT FOR FUEL CONTROLS FOLLOWING A PROTEST

All requests for fuel control following a protests or an appeal must be accompanied by a deposit of 600 €, paid to the FIM.

After the last control :

- the winning party will have its deposit reimbursed.
- the losing party will have to pay the costs of all the controls carried out after deduction of deposits which it has already paid.

1.29 SANCTION FOR NON-COMPLIANCE WITH THE FUEL RULES

A fuel control may be carried out in accordance with Art. 2.10.5 of the Sidecar Technical Regulations. A rider whose fuel does not correspond to the technical requirements will be sanctioned as follows:

1. Exclusion from the whole event in question independent of the moment of the fuel sampling;
2. Fine of 500 €;
3. Payment of all costs connected to the fuel test(s) for his case.

1.30 CHAMPIONSHIP POINTS AND CLASSIFICATION

1.30.1 Riders will compete for the FIM Sidecar World Championship.

1.30.2 For riders, the points will be those gained in each race.

1.30.3 For each race, Championship points will be awarded on the following scale:

1st	25 points
2nd	20 points
3rd	16 points
4th	13 points
5th	11 points
6th	10 points
7th	9 points
8th	8 points
9th	7 points
10th	6 points
11th	5 points
12th	4 points
13th	3 points
14th	2 points
15th	1 point

1.30.4 All races will count for the Championship classification.

1.30.5 In the event of a tie in the number of points, the final positions will be decided on the basis of the number of best results in the races (number of first places, number of second places etc.). In the event that there is still a tie then, the date in the Championships at which the highest place was achieved will be taken into account with precedence going to the latest result.

1.30.6 In the case where a rider participates on different machines, it is the make of the machine with which he obtained the most points that will appear next to his name in the final classification, without, however, modifying the calculation for the Constructors' classification.

1.30.7 The World Champions are obliged to attend an official FIM ceremony.

1.31 INSTRUCTIONS AND COMMUNICATIONS TO COMPETITORS

- 1.31.1** Instructions may be given by the International Jury and/or Clerk of the Course to teams and/or riders by means of special circulars in accordance with the Regulations. Circulars **must** be posted on the official notice board. Posting on the official notice board will be deemed as proof of delivery.
- 1.31.2** All classifications and results of practice and the race, as well as all decisions issued by the officials, **must** be posted on the official notice board. Posting on the official notice board will be deemed as proof of delivery and official publication.
- 1.31.3** Any communication from the International Jury or the Clerk of the Course to a team or rider shall be communicated in writing. Similarly, any communication from a team or rider to the International Jury or the Clerk of the Course shall also be made in writing.

SUPPLEMENTARY REGULATIONS

1. ANNOUNCEMENT

The on behalf of
will organise the at the circuit
This meeting will be held on and will count towards the

2011 FIM Sidecar World ChampionshipIMN:

2. THE SECRETARIAT OF THE ORGANISING COMMITTEE

Address of the organising committee:

Before the:

After the:

During the meeting:

3. CIRCUIT

The length of the circuit is km.

The race will be run clockwise / anti-clockwise.

A drawing of the circuit is enclosed.

4. JURISDICTION

The meeting will be held in accordance with the FIM Sporting Code, the CCR rules and these Supplementary Regulations.

The Organiser also commits to respect as much as possible the "Green line" charter of good practice.

5. OFFICIALS

- Jury President:
- Jury members:
- FMNR Delegate:
- Head of organisation:
- Clerk of the Course:
- Secretary of the meeting:
- Technical Director:
- Chief of technical inspections:
- Chief timekeeper:
- Chief Medical Officer:
- Environmental Steward:

Address of Jury members during the meeting:

6. NUMBER OF MACHINES ALLOWED

Practice :
Admitted to the start of the race :
Qualified for the race :

7. ENTRIES, DEPOSIT

Applications for entry shall be made on the official forms included with these regulations.

Applications shall be approved by the rider's FMN and shall reach the organisers not later than _____ midnight.

The organiser will select the applications and advise teams within 72 hours after the closing date of entries whether their applications have been accepted or rejected.

The maximum deposit amount for transponders is....

8. TECHNICAL INSPECTION

No rider or machine is permitted onto the track unless he/it has passed the technical inspections.

9. PRACTISING

It is strictly forbidden to ride racing machines on the course outside the official practice periods.

Schedule according to Art. 1.9.

10. RACES: SCHEDULE

Schedule according to Art. 1.9.

11. PRIZE-GIVING

Place - date

12. PROTESTS

All protests shall be made in accordance with the requirements of the FIM Disciplinary and Arbitration Code and be accompanied by a fee of _____ (local currency - amount equivalent to 600 €).

13. FUEL

If fuel is supplied by the organisers at the fuel-station, it will be in conformity with Article 2.10 of the Sidecar World Championship Regulations.

14. INSURANCE

By endorsing the application form for entry the FMN of the rider certifies that the rider is insured in accordance with the FIM requirements.

In conformity with Article 110.1 of the Sporting Code, third party insurance in respect of riders covering accidents occurring during the meeting including practices will be the responsibility of the organiser.

This insurance includes a guarantee of _____ (local currency).

The organiser disclaims all responsibility for damage to a machine, its accessories and components arising out of an accident, fire or other cases.

15. RENUNCIATION OF ANY RECOURSE AGAINST SPORTING AUTHORITIES

Apart from the requirements of the FIM Sporting Code, riders and teams by participating renounce all rights of appeal against the organiser, his representatives or agents by arbitration or before a tribunal or any other manner not foreseen by the FIM Sporting Code for any damages for which they could be liable in consequence of all acts or omissions on the part of the organiser, his officials, representatives or agents in the application of these regulations or contributed to or arising out of their actions.

Enclosures:

- drawing of the circuit
- entry form

Place and date:

The President of the Organising Committee:

The Clerk of the Course:

The Secretary of the Meeting:

Approved on:

(FMNR)

Approved on:

(FIM/CCR)

Meeting:

.....**IMN:**.....

Jury meeting No. 1

The first Jury meeting will take place 1 1/2 hours before the beginning of the free practice (in accordance with the SR of the event).

Venue: Date: Time:

End:

1. Presence:

1.1 Members of the Jury with voting rights

President:

Member:

FMNR Delegate:

1.2 Members of the Jury without voting rights, designated by the FIM

Technical Director:

Medical delegate:

1.3 Clerk of the Course

.....

.....

1.4 FMN delegates

.....

.....

1.5 Environmental Steward

.....

.....

1.6 Others

.....

.....

2. Supplementary Regulations

- third party insurance policy
- possible alterations
- additions

3. Approval of the entry list
4. Condition of the track
5. Condition of services
Timekeeping, results, communications, sanitary installations, paddock, pits, etc.
6. Fire fighting procedure
7. Next Jury meeting

The International Jury

The President The Secretary

Meeting:

...**IMN:**.....

Jury meeting No.

Venue: Date: Time:
End:

1. Presence:

1.1 Members of the Jury with voting rights

President:

Member:

FMNR Delegate:

1.2 Members of the Jury without voting rights, designated by the FIM

Technical Director:

Medical delegate:

1.3 Clerk of the Course

.....
.....

1.4 FMN delegates

.....
.....

1.5 Environmental Steward

.....
.....

1.6 Others

.....
.....

2. Minutes of the meeting No.

3. Track Inspection

4. Technical inspections
 - 4.1 Inspections carried out

	number of riders	Total
	number of machines	
 - 4.2 Special checks carried out
 - noise
 - weights
 - others
5. Riders briefing
6. Protests
7. Rule infractions, Sanctions
8. Ratification of practice results
9. Report of the Clerk of the Course
10. Falls/Accidents
11. Starting grid
12. Closed park
13. Miscellaneous
14. Next Jury meeting

The International Jury

The President The Secretary

Meeting:

.....**IMN:**.....

Final Jury meeting

Venue: Date:

Time:

End:.....

1. Presence:

1.1 Members of the Jury with voting rights

President:

Member:

FMNR Delegate:

1.2 Members of the Jury without voting rights, designated by the FIM

Technical Director:

Medical delegate:

1.3 Clerk of the Course

.....
.....

1.4 FMN delegates

.....
.....

1.5 Environmental Steward

.....
.....

1.6 Others

.....
.....

2. Minutes of the meeting No.

3. Track Inspection

4. Final scrutineering check

5. Protests

6. Rule infractions, Sanctions
7. Ratification of the results
8. Dispatch of the results (by fax or e-mail) to the FIM
9. Report of the Clerk of the Course
10. Falls/Accidents during the races
11. Unexcused absences
12. Podium ceremony
13. Overall impression of the meeting

The International Jury

The President The Secretary

2. TECHNICAL REGULATIONS

Amendments to the technical regulations may be made at any time in order to ensure fairer competitions.

If a motorcycle is found not to be in conformity with the technical regulations, during or after the practices, the Team will be given a “ride through” penalty for the race. Further penalties (such as a fine – a suspension and/or a withdrawal of Championship points) may also be imposed.

If a motorcycle is found not to be in conformity with the technical regulations after a race, the Team will be disqualified. Further penalties (such as a fine – a suspension and/or a withdrawal of Championship points) may also be imposed.

2.1 INTRODUCTION

- a) The FIM Sidecar World Championship is for vehicles with three wheels that make two or three tracks propelled by an internal combustion engine, controlled exclusively by one driver and one passenger.
- b) Providing that the following Regulations are complied with, the constructors are free to be innovative with regard to design, materials and overall construction of the Sidecar vehicle.

2.2 TECHNICAL SPECIFICATIONS OF CHASSIS

2.2.1 Materials

- a) The use of titanium in the construction of the frame, the suspensions, the steering system, the handlebars, the wheel spindles is forbidden. For wheel spindles, the use of light alloys is also forbidden. The use of titanium alloy nuts and bolts is allowed.
- b) Titanium test to be performed on the track: Magnetic test (titanium is not magnetic).
- c) The 3 % nitric acid test (titanium does not react. If metal is steel, the drop will leave a black spot).

- d) Specific mass of titanium alloys 4,5-5, of steel 7,5-8,7 may be ascertained by weighing the part and measuring its volume in a calibrated glass filled by water (intake valve, rocker, connecting rod, etc.)
- e) In case of doubt, the test should take place at a Materials Testing Laboratory.
- f) Aluminium alloys may be ascertained visually.

2.2.3 Designation of make

When two manufacturers are involved in the construction of a motorcycle the name of both shall appear on the machine as follows:

- a) The name of the chassis manufacturer
- b) The name of the engine manufacturer

2.2.4 Minimum Weight

- a) Minimum weight fully equipped including oil, water and fuel: 225kg
- b) A 3 kg tolerance in the weight of the machine at the post-race control is accepted.
- c) At any time during the event, the sidecar shall exceed the minimum weight, regardless of the tank content.

2.2.5 Dimension of the sidecar

Maximum dimensions are (see diagram A):

Maximum width:	1700 mm (including the exhaust system)
Maximum height:	800 mm (without the top air-intake - otherwise max. height: 950 mm).
Maximum length	3300 mm
Maximum wheel base:	2300 mm

2.2.6 Distance between Tracks

- a) The distance between the tracks left by the centrelines of the rear motorcycle wheel and the sidecar wheel shall be at least 800 mm and not more than 1150 mm.

- b) If three tracks are made, the distance between the tracks of the rear wheel and the front wheel shall not be more than 75 mm apart (see diagram A).

2.2.7 Riders position, protection

- a) The rider's position shall be such that the rider's feet are positioned behind the knees when looking in the riding direction. He shall not be covered from above, nor be attached to the vehicle in anyway.
- b) Vehicles shall have a solid and effective protection between the rider and the engine. This protection shall prevent direct contact between the rider's body or his clothes and escaping flames or leaking fuel and oil.

2.2.8 Passengers position, protection

- a) The minimum dimensions of the passenger's space on the platform are (see Diagram A):

800 mm x 300 mm (may be arranged in any order).
Both measured 150 mm above the platform.

- b) Passengers shall be completely visible from above and be able to lean out to either side of the Sidecar. For this purpose, the vehicle shall be equipped with a suitable handle (grip) for the passenger to hold onto when leaning out.

Open handles for the passenger shall be ball-ended (minimum diameter 40 mm). These balls may be flattened, but in these cases any radius shall not be smaller than 8 mm.

Open handles shall never reach beyond the fairing more than half the radius of the ball.

- c) Height of the protection in front of the passenger: min.300 mm

2.2.9 Streamlining

- a) The forward extremity of the streamlining shall be not more than 400 mm in front of the foremost part of the tyre (see diagram A).
- b) The extreme rear edge of the streamlining shall be not more than 400 mm beyond the extreme edge of the rear wheel.
(see diagram A).
- c) The passenger shall not be covered from above, nor attached to the vehicle in anyway.

2.2.10 Aerodynamic Devices

Spoilers and other aerodynamic devices are authorised on condition that they do not extend beyond the overall dimensions of the bodywork and are an integral part of the fairing and/or body. These shall not exceed neither the width of the fairing nor the height of the handlebar.

2.2.11 Windscreens

The windscreen edge and the edges of all other exposed parts of the streamlining must be rounded

2.2.13 Ground Clearance

- a) The ground clearance measured over the entire length and width of the frame and other mechanical parts (engine, oil bay, exhaust and platforms) excluding the fairing, race ready, fully loaded with rider and passenger in a static racing position, shall not be less than 65 mm with the handlebars in straight position.
- b) No devices are permitted to reduce the ground clearance during the course of the race. After the race, a tolerance of – 5 mm is authorised. After a 'wet' race, this check is not performed.

2.2.14 Fixing of the Sidecar

The chassis of the sidecar shall be an integrated part of the main chassis of the vehicle. No articulation or movement between the two is allowed.

2.2.15 Steering

- a) The motorcycle shall be steered by **the front wheel only and** a handlebar.
- b) The handlebar extremities shall not be lower than the front wheel spindle nor more than 500 mm behind the front wheel spindle in the straight ahead position.
- c) The steering axis shall not be offset more than 75 mm from the front wheel centre line.
- d) The minimum width of handlebars is: 450 mm.
- e) The grips shall be attached in such a way that at least the minimum width for handlebars is reached when measured between the outside ends of the grips.

- f) Exposed handlebar ends shall be plugged with a solid material or rubber covered.
- g) The minimum angle of rotation of the handlebar and the front wheel on each side of the centre line or mid position shall be 20°.
- h) Whatever the position of the handlebars the front wheel shall never touch the streamlining.
- i) Solid stops, (other than steering dampers) shall be fitted to ensure a minimum clearance of 20 mm between the handlebar with levers and the chassis and the streamlining, when on full lock, to prevent trapping the riders fingers.

2.2.16 Control levers

All handlebar levers (clutch, brake, etc.) shall be in principle ball ended (diameter of this ball to be at least 16 mm). This ball may also be flattened, but in any case the edges shall be rounded. These ends shall be permanently fixed and form an integral part of the lever.

2.2.17 Throttle controls

- a) Throttle controls shall be self-closing when not held by the hand.
- b) Two throttle cables shall be fitted (opening and closing)
- c) An ignition cut-out shall be fitted to operate when the driver leaves the machine. This ignition cut-out system shall interrupt the primary circuit.
- d) The ignition cut-out shall be placed as near to the handlebar as possible and shall be operated by a non-elastic string of adequate length and thickness and strapped to the driver's body. A spiral cable (similar to that of a telephone wire) with a maximum length of 1 m (extended) is permitted.

2.2.18 Suspension

- a) The vertical travel of the front and rear wheel spindles under suspension action shall be at least 20 mm.
- b) The use of active suspensions is forbidden.

2.2.19 Drive

- a) The drive shall be transmitted to the ground only through the rear wheel of the motorcycle.
- b) Protection shields must be fitted for open transmission parts

2.2.20 Wheels

Maximum width, measured inside the flange walls of the wheel rim:

- a) front wheel: 9" / 228.6mm.
- b) rear and sidecar wheel: 11" / 279.4mm.

2.2.21 Tyres

- a) The surface of the tyre may be smooth (i.e. without tread grooves), or treaded.
- b) The tread pattern is unrestricted.
- c) The surface of a slick tyre shall contain three or more hollows at 120° intervals or less, indicating the limit of wear on the centre and shoulder areas of the tyre. When at least 2 of these indicator hollows become worn on different parts of the periphery, the tyre shall no longer be used.
- d) The maximum width of the tyre tread measured from the point where the wall of the tyre finishes and the tread pattern starts, to the point where the tread pattern stops and the wall of the tyre other side starts (only the section of the tread pattern normally in contact with the ground is measured) shall not exceed:
 - e) 230 mm for front tyre
 - f) 254 mm for rear tyre

- g) All tyres will be measured mounted on the rim at a pressure of 1 kg/cm² (14 lb./sq.in.)
- h) Tyres warmers are not allowed

2.2.22 Mudguards and wheel protection

- a) Mudguards shall comply with the following requirements:
- b) The front mudguard shall cover at least 100° to the rear of the circumference of the wheel, beginning at the highest point of the tyre.
- c) The Sidecar wheel shall be enclosed down to the level of the Sidecar platform on the rear and on the inside, down to the height of its axle centreline at the outside
- d) The rear wheel shall be enclosed down to the level of the Sidecar platform on the inside.
- e) When the springs are compressed to their maximum, there shall still remain a minimum wheel clearance of 15 mm to every fixed part.

2.2.23 Brakes

- a) Only ferrous brake discs are allowed. Carbon fibre brake pads are prohibited.
- b) The footbrake shall operate on all 3 wheels together
- c) This brake-system must have two separate, operational circuits. One of the circuits shall work upon two of the three wheels.
- d) If one system fails, the other system shall work efficiently.
- e) The brake system may be operated by a hand-lever.

2.2.24 Fuel Tank

- a) The fuel tank shall be independently protected from the ground.
- b) Fuel shall be contained in a tank securely fixed to the machine. Seat tanks and auxiliary tanks are forbidden.
- c) Fuel tank shall be completely filled with fuel cell foam (preferably with "Explosafe®").
- d) Non-return valves must be fitted to fuel tank breather pipes.

2.2.25 Fuel and oil filler caps

- a) Fuel and oil filler caps, when closed, shall be leak proof. Additionally, they shall be securely locked to prevent accidental opening at any time.
- b) The fuel cap shall be fitted in such a way that it does not protrude in relation to the fairing or the tank profile and cannot be torn off in a crash.

2.2.26 Fuel pumps

Fuel pump(s), fuel pressure-regulators, fuel filters and fuel lines are free. Electric fuel pumps shall be wired through a circuit which will operate together with the ignition cut-out.

2.2.27 Battery

The battery shall be covered in such a way that neither the rider nor the passenger may come directly into contact with the battery or its contents.

2.2.28 Fog Lamp

- a) Sidecars shall be equipped with a functional rear facing red anti-fog lamp.
- b) The light shall be installed at least 100 mm off the ground, located in the area between the rear wheel and the sidecar platform. The light shall be mounted on suspended body part (i.e. platform, rear of the bodywork) and ensure no obstruction from the fairing and/or the passenger, facing to the rear (with a maximum tolerance of 5° from the longitudinal axis) of the motorcycle.

- c) In case of a 'wet' race it will be mandatory to switch on this lamp

Only fog lamps with the following references are allowed:

- BITS – Helios
- ISA – EMS 90x90 ref. (6085-2)
- ISA – EMS - 90x92 ref. (6085-0)
- ISA – EMS - 120x65 ref. (6085-4)
- LIFELINE 90x90 Radial rain light
- LIFELINE 90x90 Radial rain light
- SCHLÜTER MOTORSPORT ref. 600500006, 600500007

- www.bits-racing.com
- www.isa-racing.de
- www.demon-tweeks.co.uk
- www.rennsportshop.com

2.2.29 Number plates and Backgrounds

- a) The number on the front shall be affixed in the centre of the fairing; the two side numbers shall be located on the left and right side of the fairing.

Numbers must be easily legible, of one single colour and in a clear simple font.

- b) For light coloured bodywork, there shall be a black line of maximum 8 mm all around the perimeter of the white background.
- c) The background colours and figures (numbers) are white background with black numbers. With the RAL colour table values being 9005 for black and 9010 for white.

- d) The sizes for the all the numbers are:

Minimum height:	160 mm
Minimum width:	80 mm
Minimum stroke:	25 mm

- e) In case of dispute concerning the legibility of the numbers, the decision of the Jury President/ Chief Technical Steward will be final.

2.3 ENGINE / ENGINE-INSTALLATION

2.3.1 Engine position

The engine shall be positioned in such a way that the centre-line of the engine (by definition a position midway between centre lines of outermost cylinders for transversal engines, or the crankshaft for in-line engines) shall not exceed 160 mm beyond the centre-line of the rear wheel of the motorcycle. The engine shall be positioned in front of the rear wheel. (see diagram A)

2.3.2 Supercharging

- a) Supercharging by means of a device of any kind is forbidden
- b) The direct injection of fuel is not considered to be supercharging.

2.3.3 Displacement capacities

Over 740 cc up to 1000 cc 4 stroke only 4 cylinders max.

2.3.4 Four Stroke Engine

Motorcycles engines of mass production with an FIM homologation for Superstock are allowed.

All components must comply with the homologated engine, subject to any statements to the contrary specified in the below regulations.

The machining of components, for example trough polishing, micro spraying or lightening is only authorised if expressly permitted in the following rules. The use of exotic materials such as ceramics, metal matrix or aluminium beryllium is not allowed. Parts may be omitted if not necessary for sidecar purpose.

- 1) The crankcase must remain as homologated.
- 2) Crankshaft and flywheel must remain as homologated. Balancing of the crankshaft is allowed but only trough the boreholes necessary for this purpose. No modifications to the flywheel are permitted
- 3) Connecting rods must remain as homologated
- 4) Pistons, piston rings and piston pins must remain as homologated
- 5) The original cylinder head must remain as homologated. The cylinder head gasket may be replaced.

- 6) Valves, valve guides, valve seats, valve springs and valve spring retainers must remain as homologated.
- 7) The carburettor or **the complete** injection system (**throttle body included**) must remain as homologated.

Sensors and fuel injectors must be standard parts of the homologated model, with the exception of electronic and mechanical enrichment devices which may be removed.

Intake bell mouths may be removed or altered. Homologated variable length injection inlet track devices must remain as homologated by the FIM. Inlet track devices may be removed.

- 8) Camshaft must remain as homologated.
- 9) Chain, chain-tension and chain-guides may be modified or replaced. Belt tensioning devices for belt drive systems are free.
- 10) Cam sprockets may be modified or replaced.
- 11) Only engine control units (ECU, Kit ECU) which are supplied by the manufacturer of the engine are allowed. Wiring harness, spark plugs, plus wires and sockets may be replaced
- 12) Transmission/Gearbox: No modifications are permitted with the exception of shifting components to invert gear selection. Pinions, chain sprockets, chain pitch and size may be modified. The use of an ignition breaker and a shift indicator is permitted.
- 13) The clutch system type shall remain as originally produced by the manufacturer. Clutch springs; friction and drive discs may be altered or replaced. Mechanical back torque limiting capabilities are permitted. No electronic or electrical support is allowed.
- 14) The generator must supply the battery whilst the engine is running.
- 15) Electric starter shall be in place and work. The engine shall start on the grid with the electric starter for the warm up lap before the start of the race.

- 16) Oil lubrication system is free. The oil sump and oil pump may be altered or replaced. Installation of baffle plates is allowed.
- 17) The original water pump may be replaced.

2.3.5 Air box

- a) An air-box shall be used. The original air-box may be replaced by an individual design.
- b) The air-box shall completely close around the induction. Bell mouths, the carburettors or throttle bodies may be entirely within the air box.
- c) The air-box shall be constructed in such a way as to prevent any oil discharged in the air-box from spilling on the track. This oil containment shall hold a minimum of 1000 cc of oil. The air-box shall be sealed to prevent any spillage of oil or fuel.
- d) The air-box intake size is not restricted.
- e) The air inlet into the air-box shall be above the lowest point of the air intake into the engine at the bell-mouth

2.3.6 Oil breather systems

All machines shall have a closed breather system. The oil breather line shall be connected and discharge in the air-box, for oil containment (see Art. 2.3.5.c)

2.3.7 Oil cooler, Oil tank

- a) Oil cooler shall not be mounted on or above the body of the sidecar.
- b) The location of the oil tank and oil cooler should be placed in a location where it is least likely to be damaged in an accident.

2.3.8 Oil drain plugs and supply pipes

- a) All oil drain plugs shall be tight and shall be drilled and wired in position. Oil supply lines shall be correctly and securely wired in position. External oil filters and screws or bolts that enter an oil cavity shall be safety wired.
- b) Oil lines containing positive pressure, if replaced, shall be of metal reinforced construction with swaged or treaded connectors. Manufactured solid construction oil lines, where practical, shall be replaced also.
- c) It is recommended that machines be equipped with a red light on the instrument panel. This light must flash in the event of oil pressure drop.

2.3.9 Coolants

The only liquid engine coolants permitted other than lubricating oil shall be water or water mixed with ethyl alcohol.

2.3.10 Oil and coolant containment

- a) In the area directly below the engine, the oil containment tray shall be constructed to hold, in case of an engine breakdown the total oil and engine coolant capacity used in the engine (min. 5 litres). It must be securely affixed to the chassis.
- b) The surrounding edges of the tray shall be at least 170 mm above the bottom of the tray. Any passages for chain, chain tension device, gearshift linkage etc. must be sufficiently closed with rubber sealing bellows or sealing lips to avoid any leakage of oil spray. Holes for engine mounts (hangers) shall be sealed.
- c) This tray should incorporate a maximum of two holes of 25 mm in diameter and be closed with rubber plugs. These holes shall remain closed in dry conditions and only opened when 'wet' race conditions have been declared by the Clerk of the Course.
- d) The frontal edge of the oil bay reservoir wall shall be extended upwards to arrive just below (within 20 mm) the exhaust ports of the engine.

- e) From a vertical view, the engine block shall be located completely inside the oil bay platform.
- f) The rear wheel shall be protected from any possible oil-spray. To make this protection, the engine and the rear wheel compartment shall be separated.
 - This separation shall be created by installing a solid divider (wall).
 - This wall reaches from the top of the inside of the fairing and shall overlap the rear edge of the oil tray to the rear section by at least 100 mm.
 - An additional overlapping of at least 50 mm must be installed to the inside of the catch tank in the area behind the cylinder head.
- g) All sidecars shall attach oil absorbent materials of no less a quality than 3M Product number 05656 or CEP Sorbents/ product number CEP-EP100.
- h) This material shall be securely fixed to the following areas of the sidecar:
 - The entire tray, both the bottom and inside walls of the same. The volume of material used in this area, according to manufacturer's specifications, shall absorb not less than 3 litres of oil.
 - The material shall be attached in such a way that it should be easily replaced, yet shall not become dislodged whilst on the track, and its effectiveness is not inhibited, i.e. if an adhesive is used it shall not clog the material, causing it to lose its absorbent properties.
 - In the event that oil is absorbed by the material, it shall be replaced before the next track session.
- i) All absorbent material used, shall be non-flammable by design.

2.3.11 Exhaust Pipe

- a) The exhaust pipe shall not extend beyond the width of the Sidecar and the furthest extremity of the exhaust pipe shall not exceed the vertical line drawn at a tangent to the rear edge of the Sidecar body.
- b) Exhaust pipes fitted to the side of the Sidecar shall be covered so that it is impossible for the passenger to be burnt. The ends of the exhaust pipes fitted to the Sidecar shall be so positioned or protected that it is impossible for them to become entangled with another machine.

- c) The exhaust shall discharge horizontally, either to one side or to the rear, at a maximum angle of 60° to the axis of the machine. The end of the silencer shall be of constant diameter over a distance of 30 mm.

2.3.12 Timekeeping transponder

All machines must have a correctly-positioned timekeeping transponder. The transponder must be fixed in front of the sidecar wheel, as low as possible and avoid being shielded by carbon bodywork.

Correct attachment of the transponder bracket consists of a minimum of tie-wraps, but preferably by screw or rivet. Any transponder retaining clip must also be secured by a tie-wrap.

Velcro or adhesive alone will not be accepted,

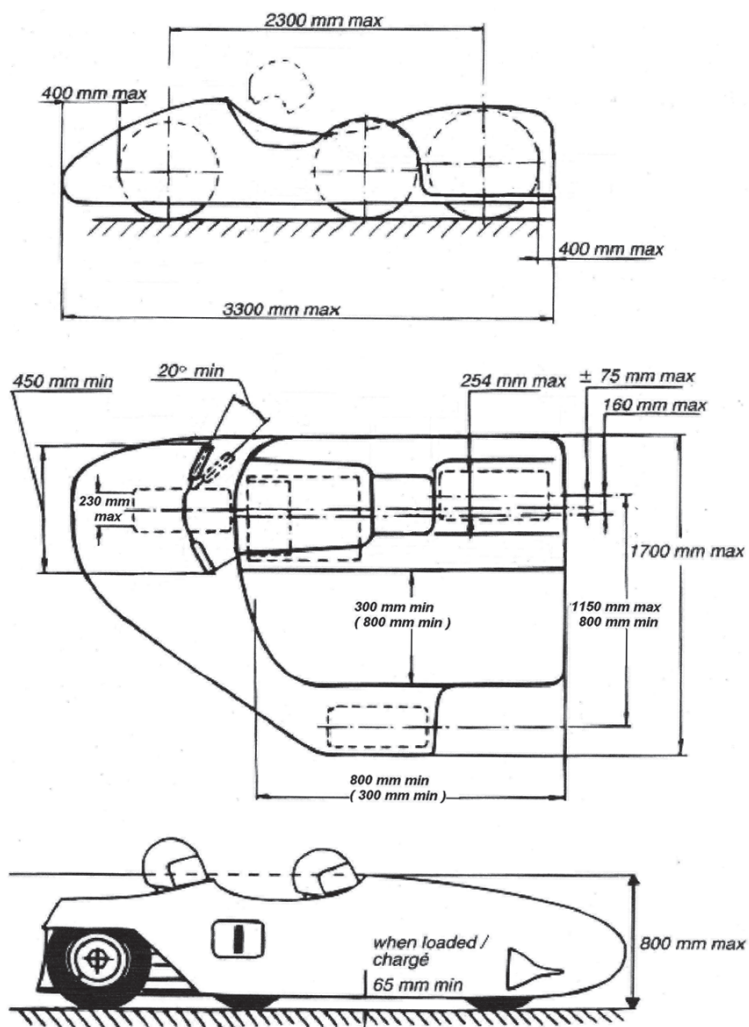

2.10 FUEL

All sidecar engines shall function on normal unleaded fuel with a maximum lead content of 0.005 g/l (unleaded) and a maximum MON of 90 according to the FIM specifications.

2.10.1 Physical properties for unleaded fuel

2.10.1.2 Unleaded petrol (incl. E10) will comply with the FIM specification if:

a) It has the following characteristics:

Property	Units	Min.	Max.	Test Method
RON		95.0	102.0	EN ISO 5164
MON		85.0	90.0	EN ISO 5163
Oxygen	% (m/m)		4.0	EN 13132 or 14517
Nitrogen	% (m/m)		0.2	ASTM D 4629
Benzene	% (V/V)		1.0	EN 238 or EN 14517
Vapour pressure (DVPE)	kPa		95.0	EN 13016-1
Lead	g/L		0.005	EN 237 or ICP-OES
Manganese	g/L		0.005	ICP-OES
Density at 15°C	kg/m ³	720.0	775.0	EN ISO 12185
Oxidation stability	minutes	360		EN ISO 7536
Existent gum	mg/100 ml		5.0	EN ISO 6246
Sulphur	mg/kg		10.0	EN ISO 20846
				or 20884
Copper corrosion	rating		class 1	EN ISO 2160
Distillation:				
E at 70°C	% (V/V)	22.0	50.0	EN ISO 3405
E at 100°C	% (V/V)	46.0	71.0	EN ISO 3405
E at 150°C	% (V/V)	75.0		EN ISO 3405
Final Boiling Point	°C		210	EN ISO 3405
Residue	% (V/V)		2.0	EN ISO 3405
Appearance	Clear and bright			Visual inspection
Ethanol (*)	% (V/V)		10	EN 13132 or 14517
Olefins	% (V/V)		18.0	EN 14517 or 15553
Aromatics	% (V/V)		35.0	EN 14517 or 15553
Total diolefins	% (m/m)		1.0	GCMS/HPLC

(*) Shall conform to EN 15376

Notes :

- (1) GC/MS methods may also be applied to fully deconvolute the GC trace.
- (2) the above maximum values for olefins and aromatics are corrected for fuel oxygenates content according to clause 13.2 of ASTM D 1319:1998.
 - (b) The total of individual hydrocarbon components present at concentrations of less than 5% m/m shall constitute at least 30% m/m of the fuel. The test method will be gas chromatography and/or GC/MS.
 - (c) The total concentration of naphthenes, olefins and aromatics classified by carbon number shall not exceed the values given in the following table:

% (m/m)	C4	C5	C6	C7	C8	C9+
Naphthenes	0	5	10	10	10	10
Olefins	5	20	20	15	10	10
Aromatics	-	-	1.2	35	35	30

The total concentration of bicyclic naphthenes and bicyclic olefins may not be higher than 1% (m/m). The test method used will be gas chromatography.

- d) Only the following oxygenates are permitted:

methanol, ethanol, iso-propyl alcohol, iso-butyl alcohol, methyl tertiary butyl ether, ethyl tertiary butyl ether, tertiary amyl methyl ether, di-isopropyl ether, n-propyl alcohol, tertiary-butyl alcohol, n-butyl alcohol, secondary-butyl alcohol

Manganese is not permitted in concentrations above 0.005 g/l. For the present this is solely to cover possible minor contamination by other fuels. The fuel will contain no substance that is capable of an exothermic reaction in the absence of external oxygen.

Lead replacement petrols, although basically free of lead, are not an alternative to the use of unleaded petrol. Such petrols may contain unacceptable additives not consistent with the FIM Fuel Regulations.

2.10.1.3 When Ethanol E85 is used,
it will comply with the FIM specification and will have the following characteristics:

Property	Units	Min.	Max.	Test Method
RON		95.0	110	EN ISO 5164
MON		85.0	100	EN ISO 5163
Vapour pressure (DVPE)	kPa	35.0	95.0	EN 13016-1
Lead	g/l		0.001	ICP-OES
Manganese	g/l		0.001	ICP-OES
Oxidation stability	Minutes	360		EN ISO 7536
Existent gum	mg/100 ml		5.0	EN ISO 6246
Sulphur	mg/kg		10.0	EN ISO20846 or 20884
Copper corrosion	Rating		Class 1	EN ISO 2160
Distillation:				
Final Boiling Point	°C		210	EN ISO 3405
Residue	% (V/V)		2	EN ISO 3405
Appearance	Clear and bright			Visual inspection
Ethanol				
+ higher alcohols	% (V/V)	75		EN 13132 or 14517
Higher alcohols (C3-C8)	% (V/V)		2.0	EN 13132 or 14517
Methanol	% (V/V)		1.0	EN 13132 or 14517
Ethers				
(5 or more C atoms)	% (V/V)		5.2	EN 13132 or 14517
Unleaded petrol				
as specified in 2.10.1.2	% (V/V)	14	25	
Water	% (V/V)		0.3	EN 12937
Inorganic chloride	mg/l		1	EN 15484
Acidity (as acetic acid)	% (m/m) (mg/l)		0.005 (40)	EN 15491

2.10.3 Air

Only ambient air may be mixed with the fuel as an oxidant.

2.10.4 Primary Tests

- 2.10.4.1** The FIM may require tests of fuels to be administered before, or at the time of delivery to, an event at which such fuels are to be used.
- 2.10.4.2** The FIM may request any person or organisation, being a potential supplier of fuel, to submit a sample for testing for conformity with the fuel specifications.

2.10.5 Fuel Sampling and Testing

- 1) The FIM Technical Director has the sole responsibility for the administration and supervision during the taking of fuel samples.
- 2) Machines selected for fuel controls will usually be amongst the first three finishers, and will be directed to the “parc fermé” and the fuel tanks removed for weight controls.
- 3) Other finishers will be chosen at random for fuel controls. A Technical Steward will be posted at the entrance to the pit box of the selected team.

Fuel sampling may take place in the pit box or in the “parc fermé”.

- 4) The fuel to be tested will be transferred into two bottles (2 samples of maximum 1ltr each), marked “A” and “B” and identified by reference to the machine from which the sample was taken. The bottles will be closed, sealed and labelled by the FIM Technical Director.
- 5) Only new bottles will be used for the fuel samples and only new materials will be used to transfer the fuel.
- 6) The Fuel Sample Declaration form will be filled out immediately, containing all information as shown in the example sheet, including the riders and machines identity, date and place of fuel sampling. A responsible team member will sign this declaration, after verifying that all the information is correct.
- 7) Sample “A” will be sent to the FIM appointed laboratory, accompanied by a copy of the Fuel Sample Declaration form. Costs for the analyses of sample “A” will be paid by FIM.

- 8) Sample “B” will be handed over to the FIM for safeguarding in case of protests and/or requirement of a counter-expertise by the FIM appointed laboratory. Costs for the analyses of sample “B” will be paid by the team concerned.
- 9) Both samples will be transported by an authorised courier.
- 10) The laboratory shall deliver the results of the fuel sample analyses to the FIM, as soon as possible after receipt of the samples, and before the Friday evening of the following event.
- 11) In the case of non-conformity, the laboratory shall notify, as soon as practical after receipt of the results, the FIM, the International Jury and the rider/team representative concerned.

Within 48 hours of the receipt of the notification of the results of the laboratory test of sample “A”, the team shall notify the FIM and the International Jury, if counter-expertise is required (or not required) for sample “B”.

Failure of the sample to correspond to the FIM fuel specifications will automatically result in the disqualification of the competitor. The result of the competitor’s fuel sample analysis (“A” or “B” sample) more favourable to the competitor will be taken into account.

2.10.6 Fuel Storage

Where the fuel is supplied by the Organiser, there shall be a officially designated and controlled fuel storage areas. Outside these areas, fuel may only be stored in metal containers.

A maximum of 60 litres of fuel, stored in a sealable container, is allowed in the competitor’s pit.

The officially designated storage and supply area shall be in conformity with the building criteria. Fire fighting equipment, protective devices and staff shall conform to the requirements imposed by the local authorities and by-laws.

The organiser shall have fire extinguishers of a size and type approved by the local by-laws, available to each competitor in the pit area.

2.10.7 Coolants

The only liquid engine coolants permitted other than lubricating oil shall be water or water mixed with ethyl alcohol.

2.11 PROTECTIVE CLOTHING AND HELMETS

Riders shall wear a complete leather suit with additional leather padding or other protection on the principal contact points, knees, elbows, shoulders, hips etc.

2.11.1 Linings or undergarments shall not be made of a synthetic material which might melt and cause damage to the riders' skin.

2.11.2 Riders shall also wear leather gloves and boots, which with the suit provides complete coverage from the neck down.

2.11.3 Leather substitute materials may be used, providing they have been checked by the Chief Technical Steward.

2.11.4 Use of a back protector is highly recommended.

2.11.5 Riders shall wear a helmet which is in good condition, provides a good fit and is properly fastened.

2.11.6 Helmets shall be of the full face type and conform to one of the recognised international standards:

- Europe ECE 22-05 'P'
- Japan JIS T 8133 : 2000 (until 31.12.2011)
- Japan JIS T 8133 : 2007
- USA M 2005 (until 31.12.2011)
- USA M 2010

2.11.7 Visors shall be made of a shatterproof material.

2.11.8 Disposable "tear-offs" are permitted.

2.11.9 Any question concerning the suitability or condition of the riders clothing and/or helmet shall be decided by the Technical Director, who may, if he so wishes, consult with the manufacturers of the product before making a final decision.

2.12 PROCEDURE OF TECHNICAL CONTROL

- 2.12.1** The rider is at all times responsible for his machine.
- 2.12.2** The Chief Technical Steward shall be in attendance for an event at least 1 hour before the technical verifications are due to commencing. He shall inform the Clerk of the Course, the Jury President and the FIM Technical Director of his arrival.
- 2.12.3** He shall ensure that all Technical Stewards, appointed for the event, carry out their duties in a proper manner.
- 2.12.4** He shall appoint the Technical Stewards to individual posts for the race, practices and final control.
- 2.12.5** One rider, or his mechanic, shall be present with the machine for Technical control within the time limits stated in the Supplementary Regulations. The maximum number of persons present at the technical verification will be the rider, plus two others. In addition, the Team Manager will also be allowed.
- 2.12.6** The FIM Technical Director/Chief Technical Steward shall inform the International Jury of the results of the Technical control. The FIM Technical Director/Chief Technical Steward will then draw up a list of accepted machines and submit this list to the Clerk of the Course.
- 2.12.7** The FIM Technical Director/Chief Technical Steward has the right to inspect any part of the machine at any time of the event.
- 2.12.8** Any rider failing to report as required below may be disqualified from the event. The International Jury may forbid any team who does not comply with the rules, or any rider who may be a danger to other participants or to spectators, to take part in the practice sessions or in the races.
- 2.12.9** The Technical control shall be carried out in accordance with the procedure and times fixed in the Supplementary Regulations of the event.

- 2.12.10** The FIM Technical Director/Chief Technical Steward will refuse any machine that does not have a correctly-positioned positive transponder attachment. The transponder shall be fixed to the machine in the position and orientation as shown in the Timekeeping information given to teams pre-season and available at each event. Positive attachment of the transponder bracket consists of a minimum of tie-wraps, but preferably by screw or rivet. Velcro or adhesive alone will not be accepted. The transponder retaining clip shall also be secured by a tie-wrap.
- 2.12.11** The rider or mechanic shall present a clean machine and in conformity to the FIM rules. He shall also present a duly filled in and confirmed technical card
- 2.12.12** An overall inspection of the machine shall be carried out in conformity with the FIM rules. Accepted machines will be marked with paint or a sticker.
- 2.12.13** FIM Technical Director/Chief Technical Steward has the final authority in case of a dispute on the conformity of the parts in question and for acceptance thereof.
- 2.12.14** Before each practice the Technical Steward shall confirm that the machine has passed the Technical control by checking the Technical control sticker before the machines go on the track.
- 2.12.15** Only accepted machines may be used in practices and races.
- 2.12.16** Approximately 30 minutes after the Technical control have been completed, the FIM Technical Director/Chief Technical Steward shall submit to the International Jury list of accepted machines and riders.
- 2.12.17** If a machine is involved in an accident, the FIM Technical Director/Chief Technical Steward shall check the machine, together with the helmet and clothing of the rider involved, to ensure that no defect of a serious nature has occurred.
- If a machine was stopped with a black flag with orange disc, the FIM Technical Director/Chief Technical Steward shall check the machine.
- In both cases, it is the responsibility of the team to present the machine (together with helmet and clothing of the fallen rider) for this re-examination in case they wish to continue.

If the helmet is defective, the Chief Technical Steward shall retain this helmet. The organiser shall send this helmet, together with the accident and medical report (and pictures and video, if available) to the Federation of the rider. If there are head injuries stated in the medical report, the helmet then shall be sent to a neutral institute for examination.

2.13 VERIFICATION GUIDELINES FOR TECHNICAL STEWARDS

- Make sure all necessary measures and administrative equipment are in place at least 1 hour before the Technical control (see separate list) is due to open (time in Supplementary Regulations).
- Decide who is doing what and note decisions. “Efficiency” shall be the watchword. Always keep cheerful and remember the reasons for Technical controls: SAFETY AND FAIRNESS.
- Be well informed. Make sure your FMN has supplied you with all technical “updates” that may have been issued subsequent to the printing of the Technical Rule Books. Copies of all homologation documents shall be in your possession.
- Inspection shall take place under cover with a large enough area (min. surface 100 sq. metres) to handle the technical verifications in two lines.
- Weighing apparatus shall be accurate and practical. Certified master weights and their certificate shall be available for verifying.
- Rules regarding sound level and measurement shall be respect

2.13.1 Preparations, procedures

At each circuit, an area shall be designated as the Technical control Area. In this area, under the control of the FIM Technical Director/Chief Technical Steward, suitable equipment will be available to conduct proper inspections.

The Technical control will be carried out in accordance with the schedule set out in the Supplementary Regulations.

Technical Stewards shall be available throughout the entire event to check motorcycles and equipment as required by the FIM Technical Director/Chief Technical Steward.

Presentation of a machine will be deemed as an implicit statement of conformity with the technical regulations.

The Technical Stewards shall inspect the motorcycles for obvious safety omissions.

The Technical Stewards shall inspect that the motorcycle conforms to all technical rules laid out in the Regulations.

All machines will be required for weight and/or sound check at the pre-race technical inspection.

The scales and sound meter will be available to the teams or riders for pre-race checking in the technical control area.

Sound test should take place in a clear area adjacent to the Technical control at least 5 metres from any possible sound reflecting obstruction.

The riders shall be aware that the weight and sound may be controlled at random during practice in the pit-lane and at the end of the race.

Claiming that the sound and weight were not officially controlled before the race will not be grounds for appeal. Conformity of the rules is the responsibility of the rider.

The FIM Technical Director/Chief Technical Steward reserves the right to spot check the weight and sound of any machines on pit row during free practice and official practice. This may occur at any time during the free practice and in the first forty minutes of any official (timed) practice. This will be carried out with the least possible inconvenience to the rider.

Machines arriving later than the first free practice shall be controlled in the technical control area.

At the conclusion of the inspections, a small sticker or coloured mark will be placed on the frame indicating that the machine had passed inspection

The Technical Stewards shall re-inspect any machine that has been involved in an accident.

The Technical Stewards shall be available, based on instructions from the FIM Technical Director/Chief Technical Steward, to re-inspect any motorcycle for technical compliance during the event.

During the technical inspection in the closed park the mechanics shall assist with the inspections. A maximum of four (4) team members per rider is allowed in the closed park during the post-race technical inspection. Downloading of data is allowed in the closed park.

Representatives of the tyre manufacturers are allowed in the closed park.

2) Practice

- Dry Practice

Every machine used in free or official practice may be checked.

The minimum checks are weight and sound. The FIM Technical Director/Chief Technical Steward may request other checks.

- Wet practice

The FIM Technical Director/Chief Technical Steward may perform certain checks during/after a wet practice.

3) Final inspection at the end of the race

Machines may be checked at least for the following compliance points:

- Weight : The weight will be checked in the condition that the machine has finished the race. No elements may be added to the machine, neither fuel, oil, water nor tyres.
- Sound : compliance with max sound limit
- Carburettors/throttle bodies + injectors :
Measurement and inspection of both inlet and outlet tract and injection I homologation points
- Engine : Engine(s), chosen at random, may be checked internally for capacity and compliance.

The FIM Technical Director/Chief Technical Steward may require a team to provide parts or samples, as he may deem necessary to confirm compliance with the rules.

4) **Appointment and attendance**

The Technical Stewards shall be present and available during the opening hours of the Technical control area. FIM Technical Director/Chief Technical Steward will instruct the Technical Stewards to verify motorcycles for compliance with technical and safety rules.

5) **Administration day / Technical control**

For all teams: min. 3 people

Tasks: Inspection of machine safety, clothing and helmets
(NO SOUND OR WEIGHT CONTROL)

Administration tasks: 1 person

a) Saturday :

Technical control: free practice and official qualifying sessions

Task: Inspection of machine safety: Sound and Weight: 3 people

Inspection of crashed machines and Technical controls 2 People

Administration tasks: 1 person

b) Sunday: Technical control during race day

Before race: safety checks on start grid: as required

After race: Technical control sound weight and carburation instruments 3 people

Displacement checks 2 people

Administration 1 person

NOTE: This is the required minimum of Technical Stewards. The number may of course be higher.

All final verification points to be decided in co-operation with the International Jury President and the FIM Technical Director/Chief Technical Steward. Post-race checks are under extreme pressure. It is important to be very well organised.

The Chief Technical Steward must report to the Jury after the final verifications.

6) Minimum Equipment list

- Revolution meter
- Sound meter and calibrator
- Slide caliper
- Depth gauge
- Steel measuring tape
- Seals
- Weighing apparatus (scales) with calibration weights
- Tools for measuring engine capacity
- Tools for measuring valve lift
- Weighing apparatus for investigation of valve weights
- Colour for marking parts
- Magnet for materials testing
- Computer to read homologation CD-Rom documents list

Documents list

- Sidecar World Championship Regulations of the current year
- Supplementary Regulations
- Homologation documents
- CD-Rom with homologations
- Technical control forms
- Writing materials

2.14 SOUND LIMITS

a) Maximum sound level: 107 dB/A (see also 2.14.5)
(with a 3 dB/A tolerance after the race)

b) Sound control :

Sound will be controlled to limit as below:

2.14.1 With the microphone placed at 50 cm from the exhaust pipe at an angle of 45° measured from the centre-line of the exhaust end and at the height of the exhaust pipe, but at least 20 cm above the ground. If this is not possible, the measurement may be taken at 45° upwards.

2.14.2 During a sound test, machines not equipped with a gear box neutral shall be placed on a stand.

2.14.3 The silencers will be marked when they are checked and it is not allowed to change them after the verification, except for any spare silencer which has also been checked and marked.

2.14.4 The driver shall keep his engine running out of gear and shall increase the engine speed until it reaches the specified Revolutions per Minute (RPM). Measurements shall be taken when the specified RPM is reached.

2.14.5 The RPM depends upon the mean piston speed corresponding to the stroke of the engine.

The RPM will be given by the relationship:

$$N = \frac{30,000 \times cm}{l}$$

in which N = prescribed RPM of engine
 cm = fixed mean piston speed in m/s
 l = stroke in mm

2.14.6 Due to the similarity of the piston stroke in different engine configurations within the capacity classes, the sound test will be conducted at a fixed RPM. For reference only, the mean piston speed at which the sound test is conducted is calculated at 11 m/sec.

	2 cylinders	3 cylinders	4 cylinders
over 740 cc	5,000 RPM	5,000 RPM	5,500 RPM

2.14.7 The sound level for engines with more than one cylinder will be measured on each exhaust end.

2.14.8 A machine which does not comply with the sound limits may be presented several times at pre-race control.

2.14.9 After the race, the sound limit shall not exceed: 107 dB/A (with a tolerance of 3 dB/A).

2.14.10 Apparatus for sound control shall be to international standard IEC 651, Type 1 or Type 2.

2.14.11 The sound level meter shall be equipped with a calibrator for control and adjustment of the meter during periods of use.

- 2.14.12** The “slow response” setting shall always be used.
- 2.14.13** Due to the influence of temperature on sound tests, all figures are correct at 20°C. For tests taken at temperatures below 10°C there will be a + 1 dB/A tolerance and for tests below 0°C, a + 2 dB/A tolerance.

2.14.14 Sound control after the competition

In a competition which requires a final examination of machines before the results are announced, this examination shall include a sound control measurement of at least the first three machines listed in the final classification.

At this final test, there will be a 3 dB/A tolerance.

2.15 GUIDELINES FOR USE OF SOUND LEVEL METERS

2.15.1 The Sound Control Officer (NCO) shall arrive in sufficient time for discussions with the Technical Director and other Technical Stewards in order that a suitable test site and testing policy may be agreed.

2.15.2 Sound level measuring equipment shall include a compatible calibrator, which shall be used immediately before testing begins and always just prior to a re-test if a disciplinary sanction may be imposed.

Two sets of equipment shall be available in case of failure of tachometer, sound level meter or calibrator during technical control.

2.15.3 Before testing, the NCO should if possible liaise with a maximum of two holders of FIM Sponsor’s or Manufacturer’s licences, or team managers, who have sound test equipment including calibrators, in order to agree the accuracy of the official sound level meter.

2.15.4 Tests should not take place in rain or excessively damp conditions. Machines considered excessively noisy shall be individually tested if conditions allow.

- 2.15.5** In other than moderate wind, machines should face forward in the wind direction. (Mechanical sound will blow forward, away from microphone).
- 2.15.6** 'Slow' meter response shall be used.
- 2.15.7** 'A' weighted setting on sound level meter.
- 2.15.8** Always round down meter reading, that is: 107.9 dB/A = 107 dB/A.
- 2.15.9** Correction
- | | |
|----------------|---------------|
| Type 1 meter : | deduct 1 dB/A |
| Type 2 meter : | deduct 2 dB/A |
- 2.15.10** Ambient temperature
- | | |
|--------------------|---------------|
| Below 10° Celsius: | deduct 1 dB/A |
| Below 0° Celsius: | deduct 2 dB/A |
- All tolerances are accumulative. Action and decisions will be taken after discussions with the FIM Technical Director/Chief Technical Steward.

3. DISCIPLINARY AND ARBITRATION CODE

The regulations will be defined by the “FIM DISCIPLINARY AND ARBITRATION CODE”.

4. CIRCUIT STANDARDS

Circuit standards will be defined by the “FIM STANDARDS FOR ROAD RACING CIRCUITS” (SRRC).

5. MEDICAL CODE

The regulations will be defined by the “FIM MEDICAL CODE”.

6. ANTI-DOPING CODE

The regulations will be defined by the “FIM ANTI-DOPING CODE”.

7. ENVIRONMENTAL CODE

The regulations will be defined by the “FIM ENVIRONMENTAL CODE”.



**FIM ROAD RACING SIDECAR
WORLD CHAMPIONSHIP**

FUEL SAMPLES TAKEN ON /..... / FOR LABORATORY ANALYSIS

RACE N°:	Sample May "A"	
	May Label N°	May Seal N°
RIDER:	Sample May "B"	
	May Label N°	May Seal N°

MOTORCYCLE MAKE: _____

TEAM: _____

The above listed details refer to fuel samples taken from the fuel tank of the motorcycle specified after the race whilst in the Check Area for a period of 60 minutes pending any protest.

Sample "A" will go to the laboratory appointed by the FIM for analysis. Sample "B" will be safeguarded by the FIM in case a counter-expertise is required.

As a responsible member of the team named on this sheet, I,

(print name): _____

have controlled the serial numbers of may seals and serial numbers of may labels and hereby certify the accuracy of the listed information.

Time: _____
(Signature)

Position in team: _____
(OWNER/MANAGER/MECHANIC)

TABLE - TABLEAU 1

	Max. increase of radius Augmentation max. du rayon (dyn) tyre / pneu	10		15		15		15		20		20		20		10	
		radial	axial	radial	axial	radial	axial	radial	axial	radial	axial	radial	axial	radial	axial	radial	axial
	Stat. distance of surface fixed from m/cycle parts Distance entre surface et éléments fixes du m/cycle (tyre / pneu)	5		5		5		5		5		5		5		5	
	Min. depth of grooves Profil min. des rainures	(mm)		1.5		2.5		2.5		2.5		2.5		2.5		2.5	
Speed Vitesse	Speed category Catégorie de vitesse (km/h)	Over Au-dessus de 210 V		Over Au-dessus de 210 V		Over Au-dessus		Over Au-dessus de 210 V		Over Au-dessus		Over Au-dessus de 210 V		Over Au-dessus de 210 V			
Rim / Width Largeur / Jante	Marking on rim Marquage sur jante (minimum)	1.50		1.50		1.50 1.60		1.60 1.85		1.85 2.15		2.15 2.15		--			
	MINIMUM (mm)	38		38		38 40.5		40.5 47		47 55		55 55		--			
Tyre Pneu	Min. diametre / mm (tyre) Diamètre min./ mm (pneu)													400			
Rim / Jante Diamètre	Maximum Diametre marking Marquage diamètre (inches/pouces)																
**Tyre width Largeur pneu	MAXIMUM (mm)															220 254	
	Minimum (mm)	50 50		50 50		63 70		70 83		75 100		83 110					
WHEEL / ROUE		front/avant rear/arrière		front/avant rear/arrière		front/avant rear/arrière		front/avant rear/arrière		front/avant rear/arrière		front/avant rear/arrière		front/avant rear/arrière			
	Max. engine cap. in cc Cylindrée max. en cc	50/80		125		250		350		500		750 1000		Sidecar (road) (route)			

SOLO ROAD RACING COURSES SUR ROUTE SOLO

** For road racing sidecars, tyre width dimensions refers to tread width. All others refer to overall width. / Pour les sidecars de courses sur route, les dimensions concernant la largeur du pneu se réfèrent à la largeur du profil. Toutes les autres se réfèrent à la largeur totale.

TEN FITTING TESTS FOR HELMETS DIX TESTS D'ADAPTATION POUR LES CASQUES

1. *Obtain correct size by measuring the crown of the head*
Avoir la bonne grandeur en mesurant le sommet de la tête
2. *Check there is no side to side movement*
Vérifier qu'il n'y ait pas de déplacement d'un côté à l'autre
3. *Tighten strap securely*
Serrer solidement la jugulaire
4. *With head forward, attempt to pull up back of helmet to ensure helmet cannot be removed this way*
Tête en avant, essayer de soulever le casque pour s'assurer qu'il ne peut pas être enlevé de cette façon



5. *Check ability to see clearly over shoulder*
Vérifier si vous pouvez voir clairement par-dessus l'épaule
6. *Make sure nothing impedes your breathing in the helmet and never cover your nose or mouth*
S'assurer que rien ne gêne votre respiration dans le casque et ne jamais couvrir le nez ou la bouche
7. *Never wind scarf around neck so that air is stopped from entering the helmet. Never wear scarf under the retention strap*
Ne jamais enrouler une écharpe autour du cou, car cela empêche l'air d'entrer dans le casque. Ne jamais porter d'écharpe sous la jugulaire
8. *Ensure that visor can be opened with one gloved hand*
S'assurer que la visière peut être ouverte avec une main gantée
9. *Satisfy yourself that the back of your helmet is designed to protect your neck*
S'assurer que l'arrière de votre casque a une forme telle qu'il vous protège la nuque
10. *Always buy the best you can afford*
Toujours acheter le meilleur que vous pouvez vous offrir

INTERNATIONAL HELMETS STANDARDS

NORMES INTERNATIONALES DES CASQUES

ECE 22 - 05 "P" (EUROPE)

The ECE mark consists of a circle surrounding the letter E followed by the distinguishing number of the country which has granted approval.

E1 for Germany, **E2** for France, **E3** for Italy, **E4** for Netherlands, **E5** for Sweden, **E6** for Belgium, **E7** for Hungary, **E8** for Czeck Republic, **E9** for Spain, **E10** for Yugoslavia, **E11** for UK, **E12** for Austria, **E13** for Luxembourg, **E14** for Switzerland, **E15** (- vacant), **E16** for Norway, **E17** for Finland, **E18** for Denmark, **E19** for Roumania, **E20** for Poland, **E21** for Portugal, **E22** for the Russian Federation, **E23** for Greece, **E24** for Ireland, **E25** for Croatia, **E26** for Slovenia, **E27** for Slovakia, **E28** for Bielo Russia, **E29** for Estonia, **E30** (- vacant), **E31** for Bosnia and Herzegovina, **E32** for Letonie, **E34** for Bulgaria, **E37** for Turkey, **E40** for Macedonia, **E43** for Japan, **E44** (- vacant), **E45** for Australia, **E46** for Ukraine, **E47** for South Africa, **E48** New Zealand.



Below the letter **E**, the **approval** number should always begin with 05. Below the approval number is the serial production number. (Label on retention system or comfort interior).



(JAPAN) JIS T 8133 : 2000

(Label affixed inside the helmet).



(USA) M2005

(Label affixed inside the helmet).



For more details consult the F.I.M. Technical Rulebook



FÉDÉRATION INTERNATIONALE
DE MOTOCYCLISME

SCAN THIS BARCODE
TO ACCESS
THE MOBILE SITE
& THE UPDATED
REGULATIONS.*



FIM-LIVE_{COM} FIM-STORE_{COM} FIM-TV_{COM}

11, ROUTE DE SUISSE | CH - 1295 MIES

ccr@fim.ch

6510007

*To download i-nigma barcode reader browse with your mobile phone to www.i-nigma.mobi