

Agnieszka Gaczkowska

**Traditional Upper Lusatian Umgebinde House
Modern Reinterpretation**

“Architecture is the art of science and wisdom used for altering the environment with the aim of satisfying human needs within the limits of ecological balance.

It might manifest itself by built forms.”(19)

Table of Contents:

Introduction

Chapter 1 – Historical Part

1.1. History and general characteristic features of the region

1.1.1. Upper Lusatia culture

1.1.2. Flora and fauna of the region

1.1.3. Architecture of Upper Lusatia

1.1.4. Historical urban set-up of the analyzed region

1.1.5. History of the development of analyzed villages

1.1.6. History of the district Weigsdorf (Gmina Wigancice Żytawskie)

1.2. Beginnings of the KWK Turów coal mine

Chapter 2 – Analytical Part

2.1. Urban Planning

2.1.1. Present state of the analyzed region

2.1.2. Design guidelines

2.2. Architecture

2.2.1. Present state of houses in the analyzed region

2.2.2. Design guidelines

2.3. Elements of the traditional country house

2.3.1. Roof

2.3.2. Wall

2.3.3. Door

2.3.4. Window

2.3.5. Slab

2.3.6. Heating system

2.3.7. Cellar / basement

2.3.8. Details

2.4. Traditional building materials

2.5. Summary

Chapter 3 – Design Part

3.1. Urban planning

3.2. Site plan

3.3. Architectural project

3.3.1. Concept of the house

3.3.2. Selection of materials and technologies used in the design of the house

3.3.3. Details

3.4. Interior design

3.5. Design of details for the interior

3.6. Summary of the design (based on LEED Certification System)

Conclusion

Summary

List of figures

References

Introduction

More and more visible trend among citizens of various bigger agglomerations pushes their dwellers to seek refuge in the idealized country houses. Naive patterns concerning country architecture are thus repeatedly used by the newcomers in all regions regardless of local Polish distinctive features in regional architecture. Consequently, houses with typical city-like features or those mistakenly treated as country-like, crop out in the countryside.

This work aims at providing a contemporary family with a modern country house that would respect both - regional building tradition and current needs of a 21st century household.

A village called Weigsdorf (Wigancice Żytawskie) has been chosen as localization for the design. This region has been selected due to its unique architecture. This Polish-Czech-German borderland rich in examples of umgebände constructions has been treated as a formal and historical context for the newly designed house.

The first chapter of this work consists of a thorough analysis of the regional architecture carried out on various levels. Consequently, proceeding sub-chapters focus on more and more detailed information. Beginning with Upper Lusatia region via village Weigsdorf (Wigancice Żytawskie) the chapter ends with the analysis of the selected site.

One of sub-chapters presents the development of Turów coal mine, that determined the history of the region.

Chapter two includes analysis of overall urban outset of the region with focus on Weigsdorf (Wigancice Żytawskie). Consequently, clear guidelines for future architectural trends have been summarized and presented graphically.

Chapter three gathers conclusions formed on the bases of previous two chapters. It comments upon certain solutions for contemporary houses that could be suitable for the selected village and presents them in a form of model house for the selected model of contemporary family.

As a context for all the chapters, broad quotations from the theory of architecture and urban planning have been used as an explanation for design decisions. They aimed at illustrating the need of adopting responsible design methodology for contemporary country house design.

This work did not aim at establishing one model design, but at presenting the methodology for drawing inspiration from the traditional regional architecture. It pinpointed its' advantages as a source of old local wisdom.

Chapter One

1.1. History and general characteristic features of the region

Architecture of country houses up till 19th century in Poland was mainly dependent on abilities of craftsmen. The final form of a house was a sum of skills and creativity of a given carpenter.

As it has been in the case of historical umgebinde houses, when the quality of carpenters' works grew with their experience and houses evolved from generation to generation, modern houses should become another step in the development of a regional umgebinde house. Therefore, in chapter one the focus is put on the historical context as it aids in understanding mechanisms that triggered such and not other, development of this structure.

1.1.1. Upper Lusatia culture

Analyzed villages are localized in a region of the so-called "Worek Turoszowski". It is a Polish part of Upper Lusatia (Górne Łużyce), that due to specific history has preserved its' unique architecture.

Natural borderlines of Upper Lusatia (Górne Łużyce) are river Kwisa (Eastern border) and Pulsnitz (Połecznicza) (Western border), Jizera Mountains (Góry Izerskie) (Southern border) and Lower Silesian Wilderness (Bory Dolnośląsko-Łużyckie)(Northern border). This terrain amounts to 7200 square kilometers.

Historically, Lusatia (Łużyce) has been in the Czech realm (till 1635) for the longest period of time (when taking into consideration all of the three neighboring countries). After that time, it has been under the influence of Saxons and since 1815 it has belonged to Prussia. After the defeat of the Third Reich in 1945, Eastern Part of Lusatia has been formally granted to Poland.

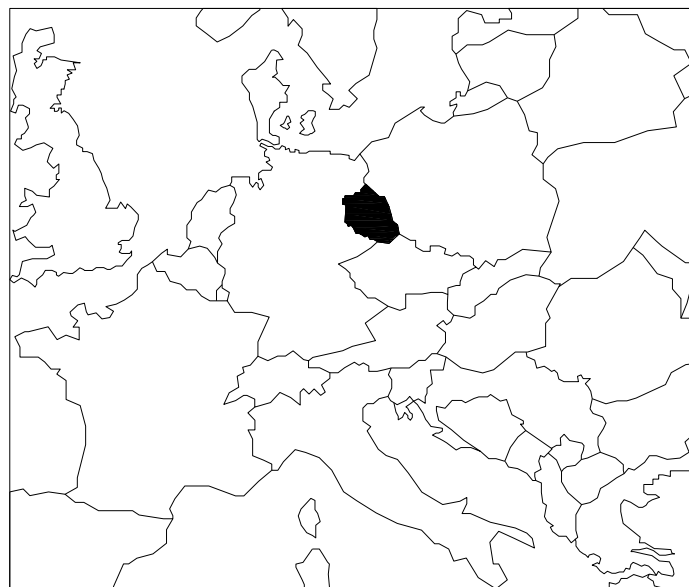

Fig.1. A map illustrating localization of Lusatia in Europe (Author's scheme)

Lusatia culture has emerged in the late Bronze Age (1300 – 300 BC) and included majority of Oder (Odra) and Vistula (Wisła) basin. This culture has been characterized by burial rite (burning dead bodies), agriculture and breeding animals, wooden architecture and bronze tools (1).

The name Lusatia has been coined in the Middle Ages (1). Around 14th century the distinction between Upper and Lower Lusatia has started to be used. In the second half of 15th century names *Upper* and *Lower* Lusatia used till the present day have first appeared in written documents¹

Agriculture, mainly rye cultivation, cattle and horse breeding, fishing and bee keeping have been dominant occupation of peoples inhabiting this region (1).

In the second half of the 19th century Lusatia has witnessed rapid economic growth that has been additionally accelerated by the development of rail.

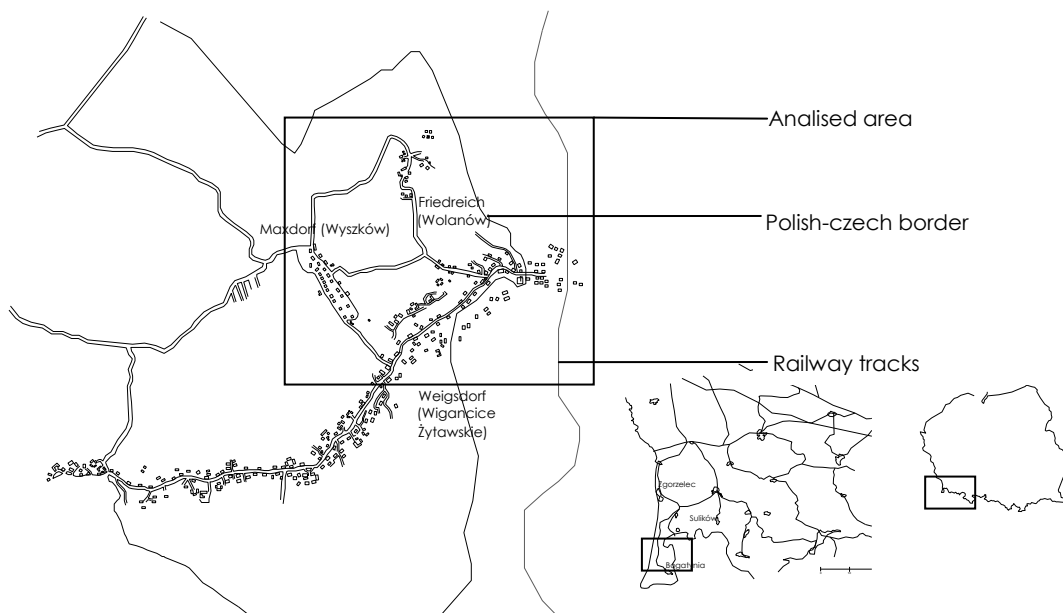

Fig. 2. A map illustrating localization of railway in the neighborhood of the analyzed area.

After 1945 when Eastern part of Lusatia has become Polish territory, it has also become a destination for a massive migration. On the basis of Potsdam Treaty (1945) German People were to leave Polish territory therefore between 1945 and 1947 majority of them have been removed from the region of 'Worek Turossowski'. Unfortunately – altogether with Germans, the native peoples such as Sorbs (Serbołużyczanie) have been removed as well.

Inhabiting Lusatia territory has become a priority for Polish government. First Poles to live in that region were former prisoners and compulsory workers also administrative clerks that were treated as guardians for the new Polish administration. Uncertain borderland status of this region did not seem inviting for civil dwellers. However some civil dwellers have also found their refuge in

¹ The name „Upper Lusatia” (Górne Łużyce) – „Lusatiae Suerioris” has been used for the first time in 1465 (1).

Lusatia. They have come from such districts as: Lodz (Łódzkie), Lublin (Lubelskie), Warsaw (Warszawski), Krakow (Krakowskie), Kielce (Kielecki), Rzeszow (Rzeszowski), Bydgoszcz (Bydgoski), and Greater Poland (Wielkopolska). However the most numerous group of settlers consisted of former dwellers of Eastern Parts of Poland that after 1945 have become USSR territory. These peoples came mainly from such regions as Tarnopol (Tarnopolski) (13%), Vilno (Wileński) (11,3%), Lwow (Lwowski) (10,4%) and Stanisławów (Stanisławowski) (6,1%) (1).

These incomers have been forced to put a lot of effort into the development of Lusatia. It was not an easy task due to the peripheral character of that land. Between 1945-1947 the majority of industrial companies in Goerlitz (Zgorzelec), Lauban (Lubań), Seidenberg (Zawidów) and Reichenau (Bogatynia) have started to function again, however Lauban (Lubański) and Goerlitz (Zgorzelecki) districts have been least developed in Poland. This situation has changed when Turów coalmine has started to be built.

1.1.2. Flora and fauna of the region

Climate

Majority of the Eastern part of Lusatia is localized in the Goerlitz region, which is the warmest climactic area in the Sudetes. Average temperature in winter is 8 degrees Celsius and summer – 14 degrees (1).

Vegetation

Former woods of the Jizera Mountains (Góry Izerskie) have been cut out along with the development of human settlements in the Middle Ages. A certain type of policy introduced in 18/19th century has greatly changed the structure of remaining woods. Scots Pine (Śosna Zwyczajna) a species that has originally been 16% of the overall trees in the Jizera has suddenly become dominant. Nowadays, many species that have been absent for years, now do come back to the local woods. Flora has again become rich in rare Polistychums (Paprotniki), numerous species of plants such as Round-leaved Sundew (Rosiczka Okrągłolistna) and others included in the 'Polish Red Book of Plants'. (1)

Animals

In the past, Lusatian woods hosted Aurochs (Tur) and European Bison (Żubr) and Eurasian Lynx (ryś). Now one may encounter Moose (Łoś), Beaver (Bóbr), Wolf (Wilk), Fox (Lis) etc. as well as 14 species of bats and many other mammals.

Upper Lusatia Fauna is exceptionally rich in birds. There are over 170 clutching species of birds (ptaki lęgowe) - 12 of them are included in the 'Polish Red Book of Animals'.

There are also 15 species of Amphibians (Płazy) – nearly all of the species inhabiting Polish territory –and reptiles (Gady), not to mention a big number of smaller animals.

There is one fauna curiosity that could have been encountered in the region some years ago. In local streams such as Nysa Łużycka, Kwisa a sweet-

water pearl mussel called *Margeritifera margeritifera* has lived in colonies of various sizes. Such colonies have still functioned in 1894 in Koci Potok, Leśna and Osiecznica streams, however since that time, there are no evidence of its existence and nowadays this species has obtained the status of extinct (G).

1.1.3. Architecture of the Upper Lusatia

In the contemporary times, Upper Lusatia is divided between three countries: Poland, Czech Republic and Germany, but it has still preserved many of its unified features concerning material culture. Building tradition is one of them.

Umgebände construction that is characteristic to all parts of Lusatia is a specific combination of timber framing mixed with massive timber construction, and masonry. Umgebände buildings have adapted various forms dependent on their function. They could range from simple, one-story houses to 2-storey public buildings such as inns.

German term *Umgebände* is the most commonly used name for this structure. Its etymology fully reflects its meaning. German *Gebände* signifies variety of construction forms based on carpenter's connections. *Um* part indicates that the structure surrounds other constructions and is one-to-one linguistic counterpart of the structural beams surrounding massive wooden logs in the ground floor (2).

Basic elements of a typical umgebände house are: masonry part, massive wooden construction and beams surrounding the structures above.

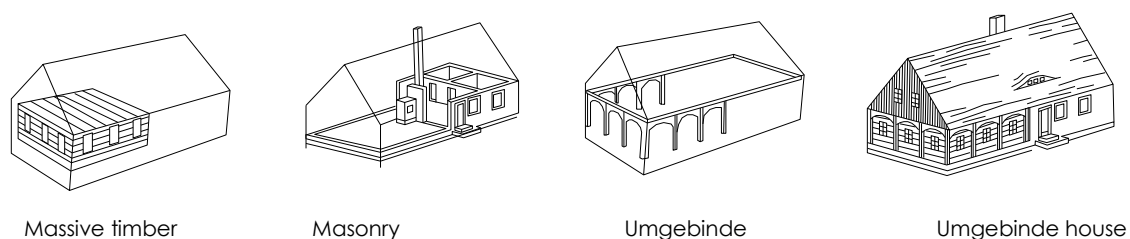

Fig.3. A scheme illustrating structure of a typical umgebände house

The illustration below (fig 4.) shows parts of a typical umgebände house enumerated above on a selected example of such building - a house preserved in Weigsdorf (Wigancice Żytawskie).

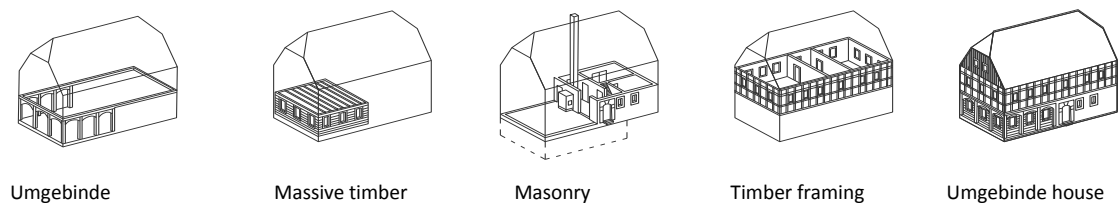

Fig. 4. A scheme illustrating the structure of an umgebände house from Weigsdorf (Wigancice Żytawskie) [Author's schemes].

In Polish literature, we may find not very numerous materials concerning this structure. In *Budownictwo Ludowe w Polsce* by Marian Pokropek (Warszawa, 1976) we may find the information, that umgebinde structures might be encountered in Lower Silesia (Dolny Śląsk) and in some villages near Łańcut, Przemyśl and Przeworsk and less often in the region of Cracow (Kraków), but especially often in the region of Goerlitz (Zgorzelec).

This information is confirmed by Ignacy Tłoczek's *Polskie Budownictwo Drewniane* (Warszawa 1980). The author states that umgebinde structure may be encountered in Poland in two regions – Lower Silesia (Dolny Śląsk) and Rzeszów region and sometimes in the area of Lodz (Łódź) (however in a simplified form).

The oldest house built in this construction dates back to 1675. It has originally been raised in Potrzebowo but now it functions in an open-air museum in Ochla (Zielonogórski Park Etnograficzny in Ochla) (18).

Elżbieta Trocka-Leszczyńska & Elżbieta Rdzawska in the article *Budownictwo przystupowe jako wspólne dziedzictwo trzech narodów - walory artystyczne detalu architektonicznego* (Szczecin 2003) enumerate basic types of umgebinde constructions. They may be divided into long-beamed (długomieczowe) and short-beamed (krótkomieczowe) that often create half-story (German: Knagge)(5).

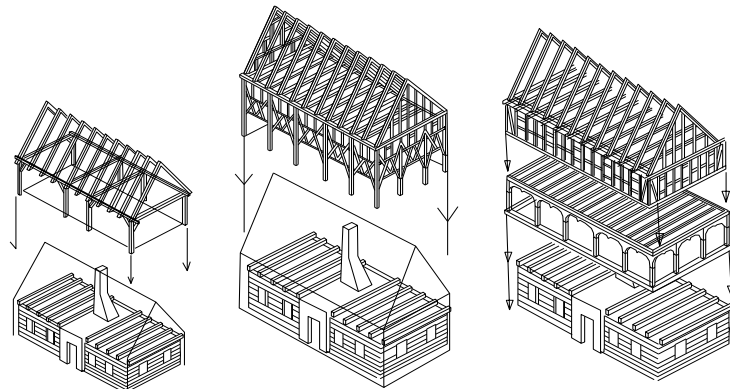

Fig. 5. A scheme illustrating the development of umgebinde structure.

1. Umgebinde supporting the roof
2. Half-storey long-beamed structure
3. Half-storey short-beamed structure.

The distance from one constructive beam to the other may also divide Umgebinde constructions. Those distances may range from wide (szerokoprzęstowe) – 6-7m to narrow (wąskoprzęstowe) – 2,5 – 3,5 m. There are however examples of the houses that incorporate both types of structures in one building.

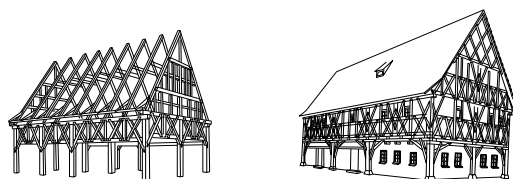

Fig. 6. Schemes illustrating some examples of umgebinde houses with various spans of constructive beams.

1.1.4. Historical urban set-up of the analyzed region

Many villages in the Worek Turoszowski region have been destroyed, therefore when designing a new house in this region; one should respect the traditional methodology for placing a building in space.

Some general information concerning urban outskirts typical for the region might be found in *Geneza, Rozwój i Prognozowanie Wiejskich Układów Osadniczych* (Kraków, 1999). A typical form of a village (Polish name: wieś łąkowa) surrounded a stream. It has been structured around two main roads with houses. The middle part of the village has been a public space (9). As it might be observed at the historical maps of Upper Lusatia villages some reminiscence of the Haulaunde colonization (kolonizacja olęderska) might also be detected (especially in the vicinity of streams) (9).



Fig. 7. Site-Plan of the Gruszków village (Grey color is used to mark the inn) (26)



Fig. 8. Site Plan of Bukowiec village (grey color is used to mark the inn) [26]

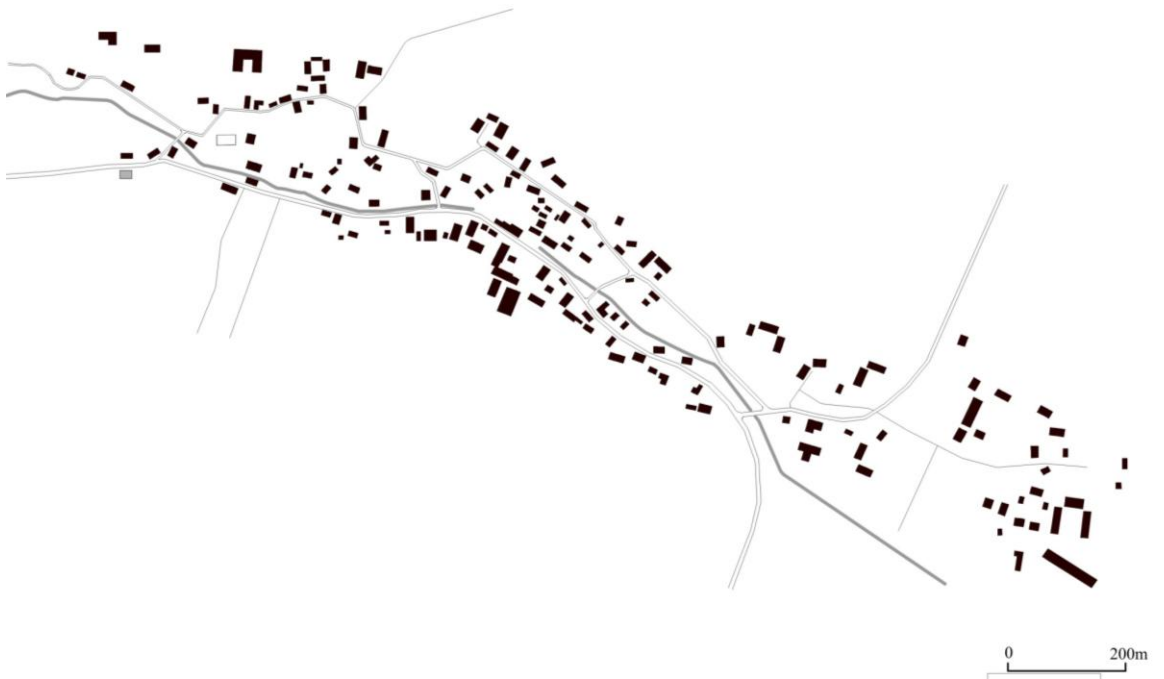

Fig. 9. Site Plan of the Miskowice village (grey color is used to mark the inn) [26]

Another factor that have influenced present urban structure of investigated villages was the history of urban development, typical to the region, that was shaped by the influence of various owners of the land. Analyzed villages: Maxdorf (Wyszków), Friedreich (Wolanów), Weigsdorf (Wigancice Żytawskie) fit into the overall trend in the region.

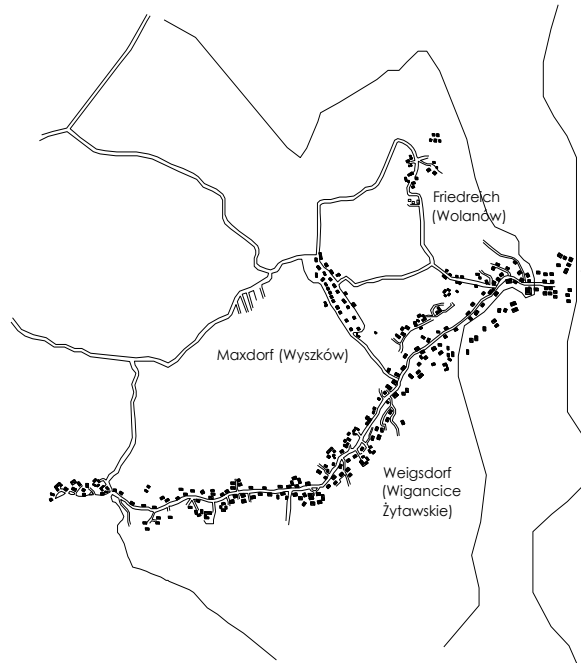

Fig. 10. Site Plan of (Wyszków), (Wolanów) and Weigsdorf (Wigancice Żytawskie) (Map from 1938) [Author's scheme].

1.1.5. History of the development of analyzed villages

Despite the fact that the first umgebinde house has appeared in a Czech town called Frytlant (1), this wooden structure has rapidly spread throughout the Upper Lusatia region.

It is also present in Polish region called *Worek Turossowski*. This region has derived its name from a town called *Turossów*. Its history goes back to the 14th century. It has flourished up till the 20th century, when it has been completely devoured by the coalmine KWK Turów. Some solitary buildings from the village, that have not been demolished, have been turned into coalmine offices (A).

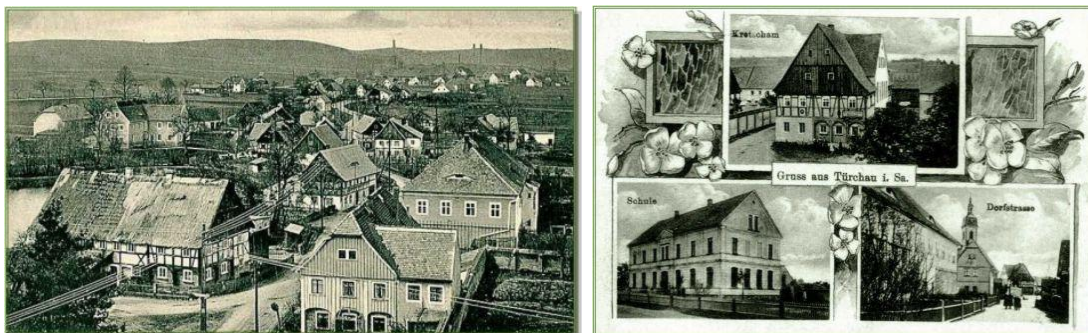

Fig 11. (Turossów) on an old postcard (A)

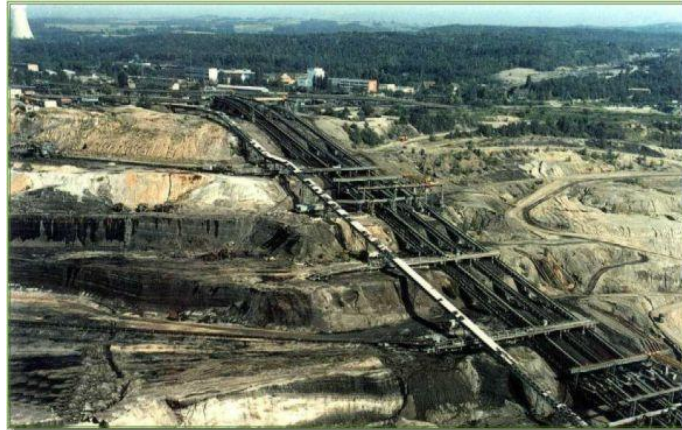

Fig. 12. (Turoszów) after it has been overtaken by the coalmine (A)

The only thing that there is left of Turoszów village nowadays is its name. What is more, this small town is not the only such spectacular example of urban demolition caused by the vicinity of coal mine KWK Turów. Such towns as Biedrzychowice, Rybarzowice, Weigsdorf (Wigancice Żytawskie) have shared such fate (H) – due to decision that has caused expansion of the coalmine after 1999 (B).

On the map below, the author has pinpointed towns and villages that have been demolished due to the coalmine KWK Turów expansion.

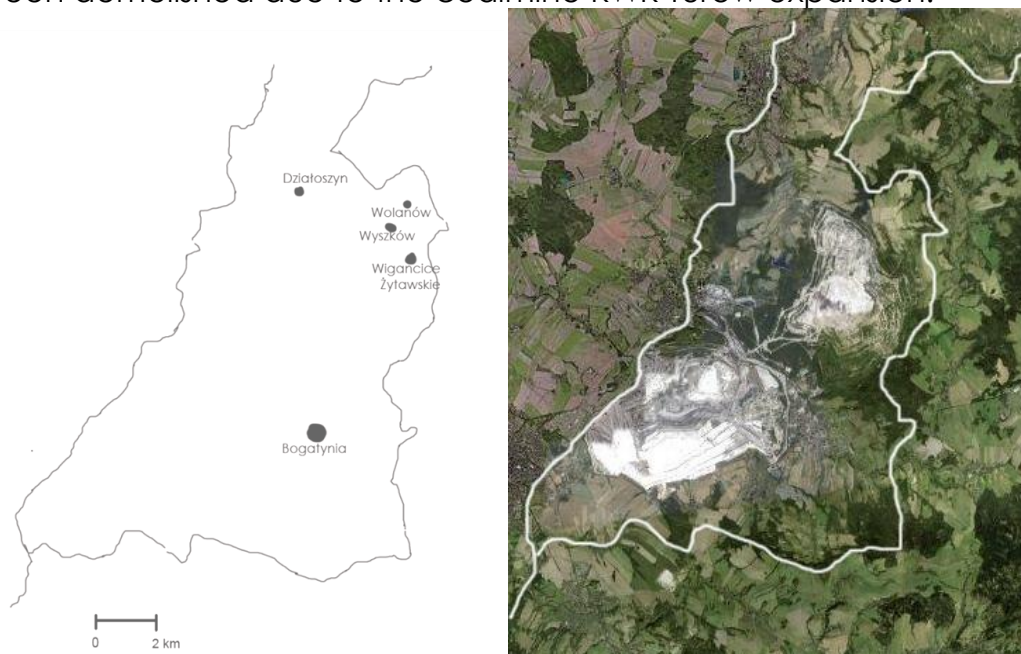

Fig. 13. A scheme illustrating localization of analyzed villages [Author's schemes] and a satellite picture illustrating the influence of the KWK Turów in the region (F)

The focus of this chapter was put mainly on villages that are located in the closest vicinity of Weigsdorf (Wigancice Żytawskie) - those that in the past have been an integral part of this town. Urban context of the designed house would not be complete without investigating the information concerning this neighbourhood. Data concerning these gone urban structures have been presented thematically – one village after another.

Dornhennersdorf (Strzegomice)

Before 1945 this town has functioned under the name *Dornhennersdorf*, while short after - as *Kurzany*. Since the second half of 17th century the town has been divided into 2 parishes – Lower Dornhennersdorf belonged to the Weigsdorf (Wigancice Żytawskie) and Upper Dornhennersdorf belonged to Zatonie. In 1837 after the abolition of the parish duty all the Protestant dwellers could deliberately change their parish into Weigsdorf (Wigancice Żytawskie). Consequently, only some of them decided to stay in Zatonie (1).



Fig.14. Dornhennersdorf (Strzegomice) on the old postcard (A).

In year 1847 Dornhennersdorf (Strzegomice) counted 731 dwellers. In 1910 – 552, in 1943 – 602, in November 1946 – 118 (84 Poles, 24 Germans and 2 Czech) (1). After the displacement of its original dwellers – this village has been completely buried under the KWK Turów coal mine's spoil tip. (A)

Zatonie

In the Middle Aged writings we may find such names as *Sibotindorf* (1303) *Seibotonis Villa* (1386), *Seybothendorf* (1387), *Seytendorf* (1405) *Sittendorf* (1430) *Syotindorf* (1485). The first after war name was *Ustronie* (1).

In 18th and 19th century this village was well known for the production of linen cloth and woolen shoes. In the first half of 19th century various fabrics have started to be produced here on the industrial scale (in 1832 there has been over 100 weavers' workshops. Before the second world war there have been 2 churches and one school (built in 1735) in Zatonie (1). In 1890 – this town had 1791 dwellers, in 1925 - 2794 and in 1943 – 2638. In November 1946 it counted only 769 people (525 Poles, 226 Germans and 18 Czech) (1).



Fig.15. (Zatonie) on the old postcard (A)

This town has also been destroyed due to KWK Turów coal mine expansion. Only a small Eastern part has still been preserved till present time. It now functions as a part of Bogatynia (1). Some houses are still inhabited however the church is deserted.



Fig.16. Photographs of some buildings that are what is left of Zatonie village now [Author's photos].

1.1.6. History of the district Weigsdorf (Gmina Wigancice Żytawskie)

Weigsdorf's history dates back to year 1360. It has originally belonged to two knight families – von Biberstein and von Weigsdorf. Since its beginning there has been a church in the village. From the 16th century on – it has frequently changed its owners – families von Schwainitz, von Gersdorf and after the Peace of Prague (1635) – one part belonged to Czech and the other to Saxons.

In 1873 a post agency has appeared in German part of the village. In 1923 Weigsdorf (Wigancice Żytawskie) has been established a district altogether with Maxdorf (Wyszków) and Friedreich (Wolanów) (villages that exist till the present day). 19th century witnessed a rapid industrialization. Due to the numerous weavers in the town – it was the field that has developed most rapidly. Between 1905 and 1910 Jute Werke (a textile factory) has been opened in Weigsdorf and after 1945 – a filial of Doltex (factory in Bogatynia) has started to function in Weigsdorf (C).

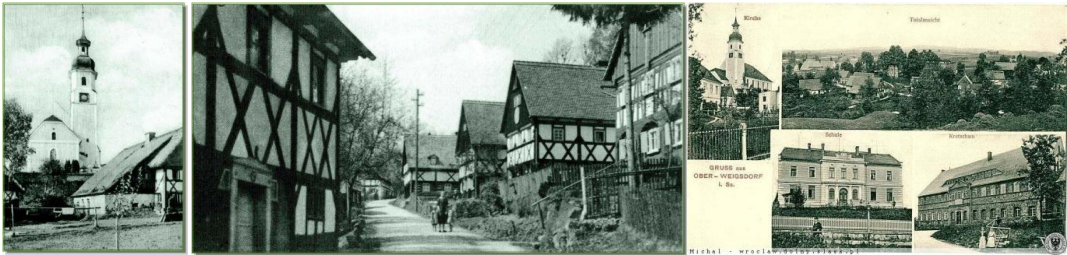

Fig. 17. Weigsdorf (Wigancice Żytawskie) on an old Postcard (C)

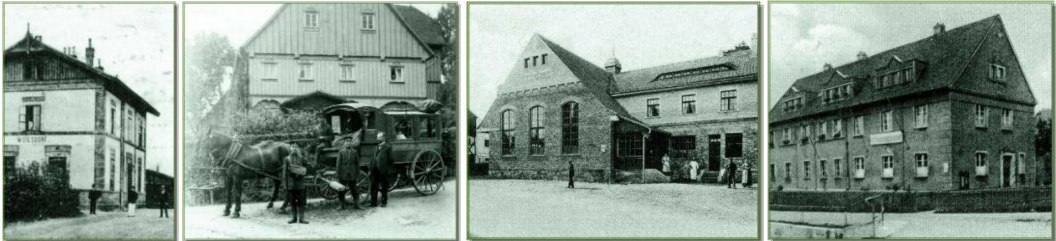

Fig. 18. Weigsdorf (Wigancice Żytawskie) on an old Postcard. From the left : local post, postal carriage, industrial buildings.

In his book, *Polskie Górne Łużyce. Przyroda-Historia-Zabytki* (Zgorzelec 2003), Waldemar Bena states that the oldest documented writings concerning Weigsdorf (Wigancice Żytawskie) come from 1334. In 15th century; the village was called *Weigsdorff*, *Waigisdorf*, *Weissdorf* and *Weigsdorf* (this form turned out to be the most popular). First after-war names were: *Pogórze* and *Stawniki*.

This village could have originated around 13th century during the German colonization. Some historical sources state that Weigsdorf (Wigancice Żytawskie) have started as a part of jurisdiction of Zittau (Żytawa). What is interesting – for some time it has also been part of Frydlant-Zawidów country owned by von Biberstein family (who governed this region at that time).

The majority of the village – Lower Weigsdorf (Wigancice Dolne) and Middle Weigsdorf (Wigancice Średnie) – was owned by Frydlant owners – firstly – von Weigsdorf family and after 1530 – von Schwainitz family. The remaining part of Weigsdorf (Wigancice Żytawskie) was directly owned by von Biberstein family. Despite being close to Zittau (Żytawa), Weigsdorf (Wigancice Żytawskie) did not belong to the district of (Zawidów) or Zittau (Żytawa) – as a proof of that – church documents from 1384 from both towns do not mention Weigsdorf (Wigancice Żytawskie) (1).

When in 1635 Upper Lusatia (Górne Łużyce) has belonged to Wettyn family it has been the subject of various conflicts that, in the end, determined Polish – Czech borderline. Lower Weigsdorf (Wigancice Dolne) has been incorporated into the Czech territory and has functioned as Visnova (1). For over 200 years the exact borderline has been unclear. Probably owing to that fact – both, the school and the church have not been demolished during the expansion of the KWK Turów (and they are both now on the Czech side of the borderline).



Fig. 19. A school from Weigsdorf (Wigancice Żytawskie). From left: on a historical postcard (C) and on a photo [Author's photography]



Fig. 20. A church from Weigsdorf (Wigancice Żytawskie) that has been preserved till the present day on the Czech territory. From left: old postcard (C) and a contemporary photograph [Author's photo].

Many small industrial companies started to appear in Weigsdorf (Wigancice Żytawskie) at the end of century. M Beckert and Co. has opened a linen factory, O. Hensenberg has opened a weaving factory and eleven years later, Ernest Hartdorf has launched a similar business. Further development of the industry was not possible due to similar distance from various communication paths. In 1854 a new connection from Weigsdorf (Wigancice Żytawskie) to Działoszyn and Ostritz has started to function, however it was still not enough. In 1785 a rail track from Frydlant to Zawidów in the vicinity of Weigsdorf (Wigancice Żytawskie) was opened, however, people would have to cross the Polish Czech border in order to use it, which made it inconvenient. At the end of 19th century, many local entrepreneurs have made their effort to lead to building new rail track Weigsdorf (Wigancice) - Bogatynia and Weigsdorf – Hirshfelde.

Despite the fact that Weigsdorf (Wigancice) are long gone, Maxdorf (Wyszków) and Friedreich (Wolanów) still exist (1).

Maxdorf (Wyszków) dates back to 1666, when Erazm von Gesdorf, the owner of the Middle Weigsdorf has settled 6 protestant families. Further development of the village has happened in 1735 as an order of Erdmann Ferdynand von Feussler – an heir from Weigsdorf (Wigancice Żytawskie)(1).

Friedreich (Wyszków) has been set up by Fryderyk Ludwik von Goldschid von Goldberg in 1765. (1) It has remained as a small satellite village of Weigsdorf (Wigancice Żytawskie). In the 80ties it was famous for hosting the laboratory farm of the Polish Acedemy of Sciences (PAN) where Żubroń - Polish hybrid of domestic cattle and wisent was raised.

In 1943 Weigsdorf (Wigancice Żytawskie) altogether with Maxdorf (Wyszków) counted 1479 dwellers. In September 1947 there have been only 481 people (including 17 German and 6 Czech) in Weigsdorf (Wigancice Żytawskie) and around 197 (including 4 Germans) in Maxdorf (1).

Weigsdorf (Wigancice) has been demolished due to a decision of KWK Turów coalmine. Last 33 families have moved out from this place between 1991 and 1995. Nowadays only some remnants of former houses prove that there has once been a flourishing town in this place.



Fig 21. Remnants of former buildings in Weigsdorf (Wigancice Żytawskie) [Author's photos].

Former owners of houses in this village claim, that Weigsdorf has been saved from a formal annihilation by one of their dwellers. The man has obtained his financial compensation for the house, however did not move out. He had lived in Weigsdorf till the end of his life. Owing to that fact – the town could not have been formally removed from the map. Consequently it functions till the present day (C).

1.2. Beginnings of the KWK Turów coal mine.

The first written information concerning coal in Zatonie comes from around 1427 (1). In old chronicles – an information about coal in Worek Turossowski region may also be found. Around 17th century coal has started to be explored and in 19th century there has been over 100 private coal mines in the region (D).

Beginning with 1890, smaller mines have been closed to make space for the big ones. In 1904 Herkules Joint Stock Company (Herkules Spółka Akcyjna) has started exploitation of coal on an industrial scale. In 1908 a patent (brykietownia) has started to function and three years later Hirsfelde Power Station began its work (D).

After II world war Hirsfelde Power Station was supervised by the Soviet government and after nationalization it formally belonged to the Polish treasury (Skarb państwa). The company has become divided by the new afterwar borderline. River Nysa Łużycka has separated the mine from power station, its repair workshops and storehouses.

After the postwar period, an era of intensive work immigration has started. Many miners from Silesia and numerous repatriates have sought workplace in Worek Turossowski region.

Around 1956 Polish miners have developed skills allowing them to hold important positions in the structure of KWK Turów Coal mine (till that time, it was rather qualified workforce from Germany). An era of constant development of the coalmine has started.

Consequently in 1958 it has become the subject of political decision to prioritize this investment as energetical safety for Poland (D).

In January 1958 first group of builders have come to (Bogatynią). This investment has obtained priority "T" – most important in these times. The coalmine altogether with Power plant has become the biggest energetical investment in Europe of that time. The investment has been completed in 1965 the company kept on developing.

In the 90ties KWK Turów has undergone a costly modernization that allowed reduction of sulfur dioxide and nitric oxide. Thanks to that in 2001 KWK Turów has been crossed out of the most poisonous companies in Poland (D).

Nowadays PGE Górnictwo i Energetyka Konwencjonalna Spółka Akcyjna – Oddział Kopalnia Węgla Brunatnego Turów employs nearly 40 000 workers. It covers over 40% of Polish energy supply per year.

Chapter Two

During the aforementioned modernization of the KWK Turów coalmine in 1999 a decision concerning the extension of the coal overburden spoil tip (leftovers after the excavation of brown coal) has been made. It stated that many of the neighbouring villages in the Worek Turossowski region will need to be deserted and will be buried under the layer of ground excavated when digging in search of coal. Shortly after this decision, many villages and towns like Strzegomice, Zawidów have been depopulated and literally buried under ground. Weigsdorf (Wigancice Żytawskie) did not completely share this fate. Dwellers have been nearly completely removed from the village however due to a change in the coalmine's policy it has not finally been covered with the spoil tip.

Ten Years after this fatal decision, then deserted village started to slowly become a hot spot for new housing. Consequently the important question arises – what should these new houses look like? Given the fact that this area was originally known for its unique architecture – new houses should correspond to this building tradition. They should also, however, stem out of contemporary technologies and answer needs of the 21st century society.

In order to come up with a design of a modern house inspired with local yearlong architectural tradition a thorough analysis of the umgebinde has been summarized in this chapter. The aforementioned analysis has been undertaken in various scales, from urban planning, via architecture, to details.

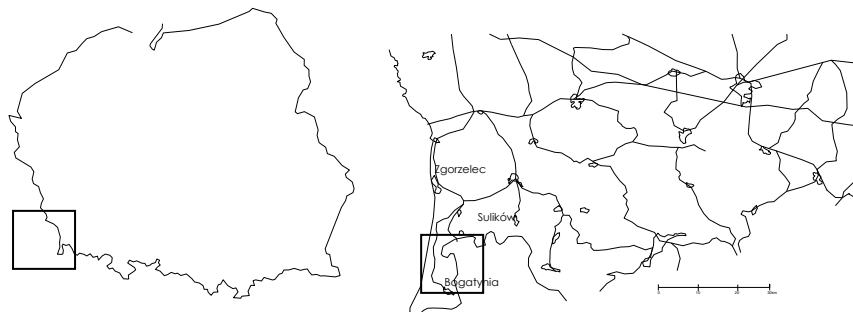

Fig.22. Localisation of the area analysed as a context for the design of the house [Author's schemes]

2.1. Urban Planning

As a basic urban structure for Weigsdorf (Wigancice Żytawskie) the author has adopted the map from 1938. The village at that point in time was at its peak development. It was also the moment when last examples of the umgebinde houses were raised. Later on the village was heading to its end (II World War period and the era of afterwar migrations) the decision about its annihilation under the overburden of coalmine's leftovers. Therefore urban outset of the village in 1938 was the result of a yearlong natural development.

2.1.1. Present state of the analyzed region.

Urban set-up of analized villages

Maxdorf (Wyszków) and Friedreich (Wolanów) (former colonies of Weigsdorf) have not been chnged during the 90ties. Weigsdorf, though deprived of all the demolished cubatures has however remained untouched when it comes to the net of local roads and greenery.



Fig.23. Urban outset of the analyzed region – present times [Author's schemes].

Traditional set-up of buildings on the site

The categorization of the set-up of buildings on the site is usually analyzed in relation to the yard – whether the buildings create inner courtyard, half-courtyard are situated linear etc.

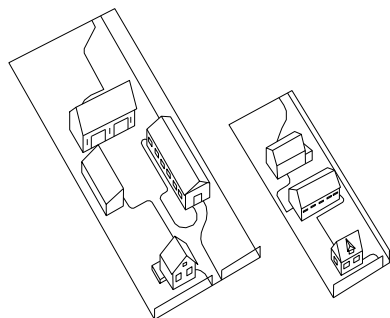

Fig.24. A scheme illustrating typical localisation of the buildings on the site [Author's schemes]

Most typical urban outsets of buildings on the site were linear and one with inner courtyard usually equipped with a well (3). On schemes below, the author has depicted typical urban setups.

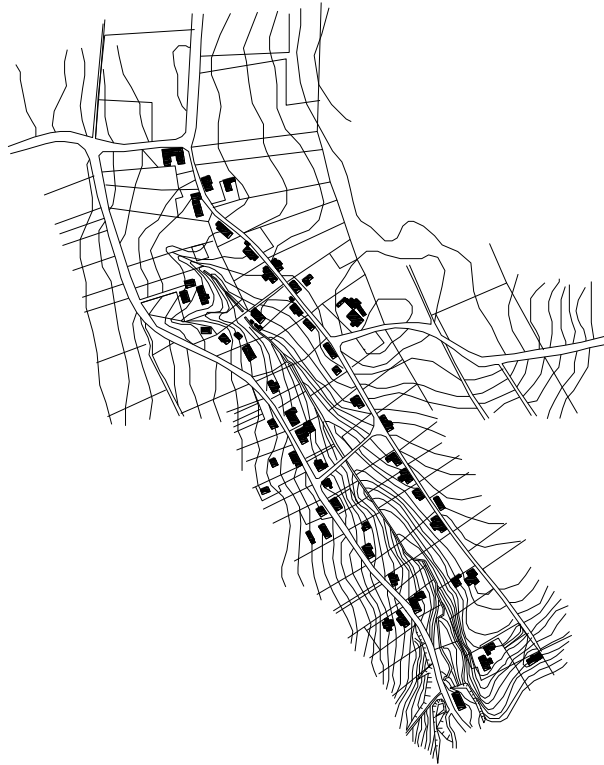

Fig.25. A scheme illustrating linear setups of houses [Author's scheme]



Fig.26. A scheme illustrating courtyards created via characteristic setups on given sites [Author's schemes]

Urban Details

On photographs below, some forms of typical groundcovers or other urban details have been gathered in order to give the overall idea of the traditional details.



Fig.27. Examples of details from Maxdorf, Friedreich and Visnova [Author's schemes]

Present state of the houses in analyzed villages

A lot of historical houses are in very bad condition. Many of them are no longer suitable for inhabiting. Many need to be demolished to give space for new buildings.

2.2.2. Design Guidelines

As Grzegorz Wojtkun in *Osiedle Mieszkaniowe w Strukturze miasta XX wieku* states, in order to make one identify with architecture, the architect has to give it an individual character with a clear functional scheme and localize it with respect to local surroundings (27). That is the reason why the localization of the new house is so important. Consequently in following subchapters, details concerning the design of a new house will be preceded by the selection of the localization and careful site plan.

Site Plan

The design of a house may not be started without the overall regulations concerning the closest vicinity that is described in the Master Plan of Reichenau (Bogatynia). In order to place the analysed site in a broader context in terms of both space and time, the author has also used 'Studium Uwarunkowań i Kierunków Zagospodarowania Przestrzennego Miast i Gminy Bogatynia' and author's own analyses.

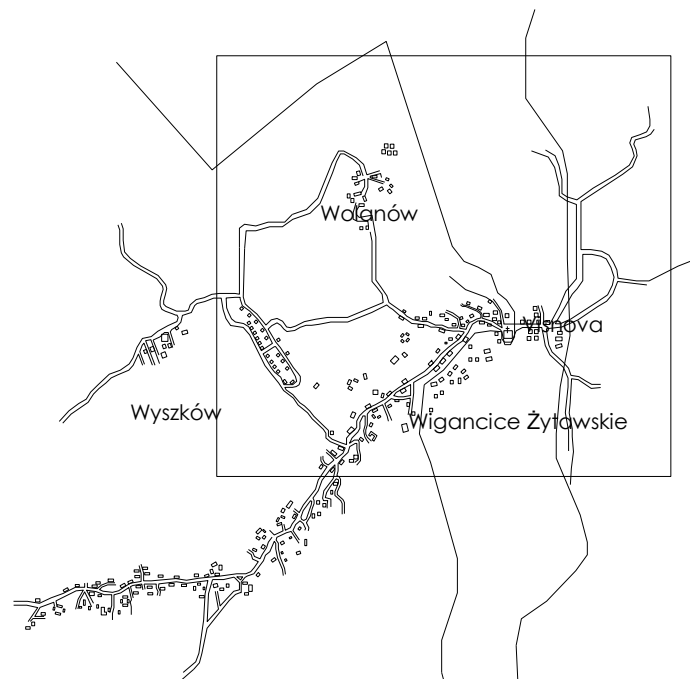

Fig.28. Analysed area marked on a scheme based on the map from 1938 [Author's scheme]

2.2. Architecture

As it has been stated in Hanna Znaniewska's and Radosław Berek's article *Proekologiczne Budownictwo Mieszkaniowe – Filozofia czy Rzeczywistość*, when one observes country housing from 17th to 20th century, one may notice some constant characteristics. Mainly, forms of houses evolve from functional minimum to more and more sophisticated forms based on

local materials. In order to provide this history in a shortened form, the author has presented it in the form of schemes.

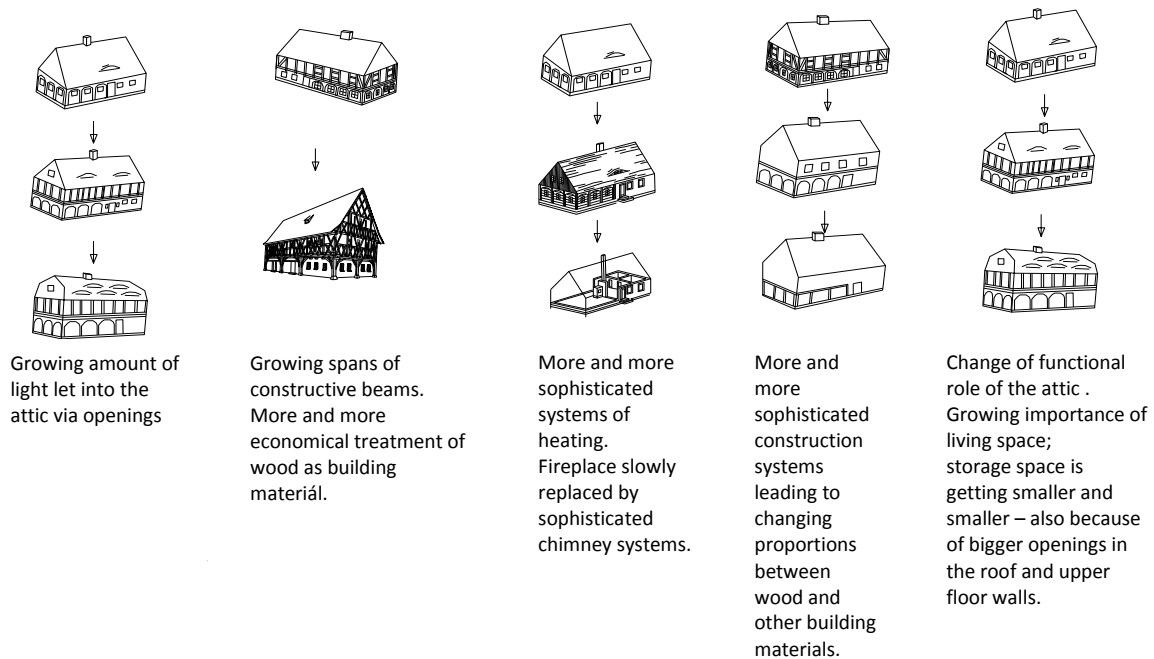

Fig.29. A scheme illustrating the development of an umgebinde construction [Author's schemes].

Umgebinde houses in Polish part of Umgebindeland are much smaller than ones in Germany and less equipped in decorative details. They are also more economical in using wood than houses in Czech Republic.



Fig. 30. Photographs of umgebinde houses in Poland and Czech Republic [Author's photos]

In Poland, bigger umgebinde buildings were not as in Germany houses, but rather public facilities like inns, post offices etc. or belonged to very rich owners.



Fig. 31. Photographs of bigger umgebinde houses in Bogatynia and Miskowice [Author's photos]

2.2.1 Present state of analysed villages

Vast majority of historical houses in analyzed villages is no longer suitable for living. Therefore it is so important to find new design that could fit into their place.

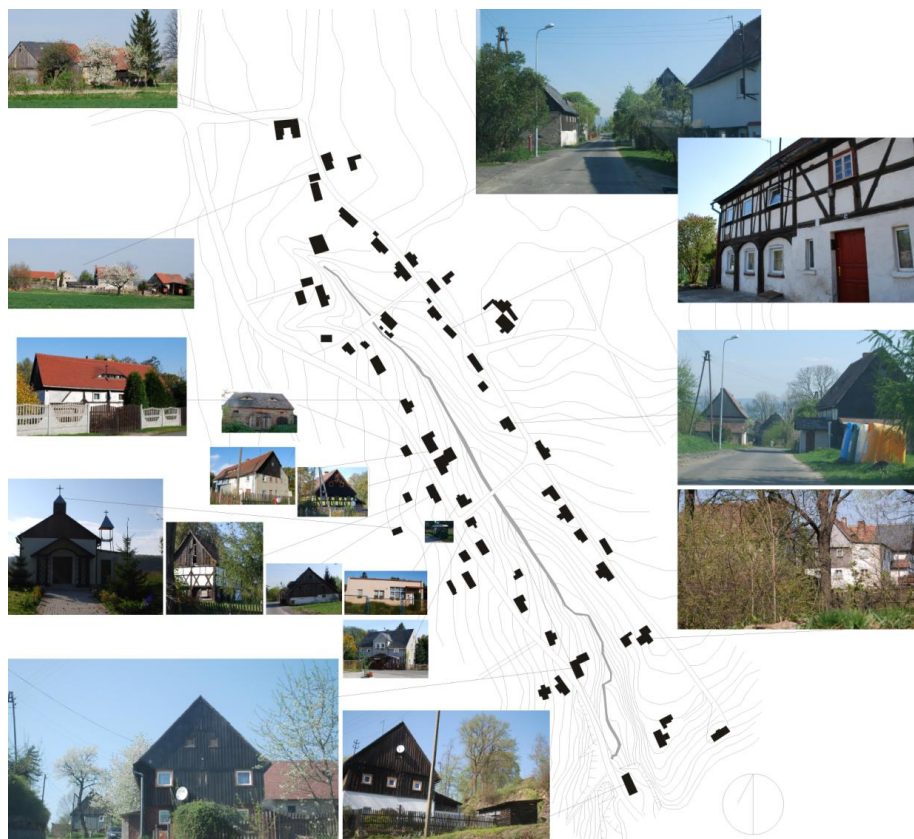

Fig.32. Wyszków – characteristics of buildings' present state [Author's schemes]



Fig.33. Wolanów – characteristics of buildings' present state [Author's schemes]



Fig.34. Wigancice remnants of a house [Author's photo]

The only umgebinde house from Weigsdorf (Wigancice) preserved till this day is *Chata Kołodzieja* – the original house translocated to Goerlic (Zgorzelec), where now it functions as a restaurant. For the purpose of this work, the said house has served as a direct source of inspiration for the newly designed house.



Fig.35. Chata Kołodzieja – facades: Eastern, Northern, Western and Southern [Author's schemes].



Fig.36. Chata Kołodzieja before (Photograph from private collection of the owner of the house) and after translocation [Author's photos]

2.3. Elements of a traditional umgebinde house

Despite the fact that architecture does evolve, buildings may still be divided into basic construction parts such as walls, roofs, slabs etc. therefore in the following part of the work these elements will be discussed one after another.

2.3.1 Roof

Stefan Szyller, a renown Polish architect (1857-1933) states, that richness of wooden structures may easily be defined by forms of roof. As we read in Ignacy Tłoczek's *Polskie Budownictwo Drewniane* (Wrocław, 1980): there are some ways to measure evolution of historical wooden structure, however it is most visible in growing spans of roofs and more and more economical use of wood as a building material. (18). Even popular leaflets published occasionally by local owners of renovation firms say: 'the most common mistake during renovation of the roof in a historical house is the use of wrong roof cover' (25).

A certain kind of measurement of the importance of the roof for the overall building shape is proportional relation to the rest of the building. It might be illustrated by the table below.

Building	Surface [m ²]		Ratio
	Roofcover surface	Building surface	
Szczyrk – a house from 19 th century	176	88	2,03
Podwalin – a house from second half of the 19 th century	135	64	2,1
Liszna - house from 1890	300	100	3,0
Rosolin – Church from 1750-51	230	42	5,45
Sękawa – Church from 1540	1100	110	10

Fig.37. A table illustrating the proportion of the roofcover floor in relation to the overall surface of the building (16) [Author's scheme]

As we may read in Tłoczek, an important characteristics of wooden buildings in Poland was that, very often, the use of the attic space for living (not storage) was unusual (18). Illustration below depicts some examples of various roof shapes that may be encountered in wooden houses.

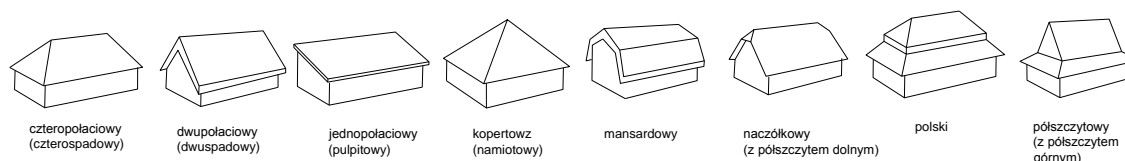

Fig.38. Traditional wooden roofs [Author's schemes]

Marian Pokropek in *Budownictwo Ludowe w Polsce* claims that the hipped roof (dach czterospadowy) was popular in Southern Poland. Other sources say, that typical for Upper Lusatia types of roof were 2-sided (dwuspadowy i naczółkowy) and sometimes mansard roof (20).

It is very important to remember about a specific roof construction that has been used in one of the houses in Weigsdorf (Wigancice Żytawskie). This mansard-like type of roof is called Polish roof (Polski dach łamany).

Its both sides are sloped at the same angle. It did not require very long logs of wood and thus became very popular (18).



Fig. 39. Photographs illustrating the variety of roof forms in Upper Lusatia [Author's photographs]

Roof windows

Most typical (for Umgebinde houses) types of roof windows are so called *oeil-de-boeuf* (Polish: *wole oka*, German: *Ochsenaugen*) that may be usually encountered in mansard roofs.

In the past, every form of window introduced into the attic space was a sort of luxury, because it led to loss of heat. Besides that, living space in the attic might be encountered in houses of rather rich owners. Poor dwellers lived in houses that made the use of attic as a storage space.

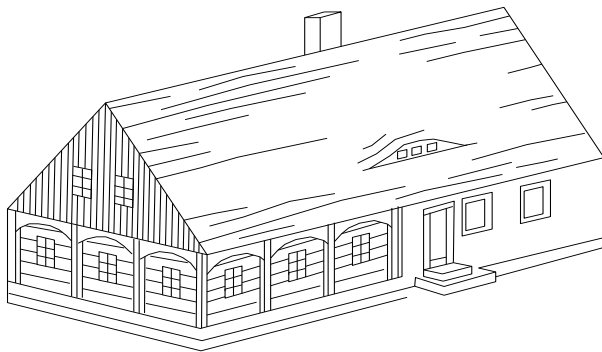

Fig 40. A scheme illustrating one of the traditional roof window type [Author's scheme]

Another type of roof window typical to upper Lusatia is a specific long narrow dormer (pol. 'lukarna', niem. 'Hechtfenster').

As it may be observed – the level of light in the attic has evolved from none to one allowing the use of the upper floors for living space.

Roofcover

Method for covering the roof is an example of a broader tendency dominating in country housing. Mainly, material used for roofcover was usually the one most accessible in situ i.e straw, wood, reed. In Sudeten, a local slate (*tupek bitumiczny*) was also frequently used as often as wood for roofcover (19).

Consequently in Upper Lusatia region we may find houses covered with either wooden shingles (*gont*) or bitumen slates (*tupek bitumiczny*). The latter one was often shaped in decorative geometrical patterns (20).

Many of these roofcovering techniques may be a perfect theme for modern architectural interpretation in the design of a contemporary umgebinde house.

One of the aforementioned types of roof cover, mainly wooden shingles, are placed in a sophisticated manner that might also be directly re-interpreted. Wooden tiles (shingles) are cut out of 8-15 cm wooden pieces and shaped so as to have a narrow edge on one side and a v-shaped channel on the other (19). They are placed on the roof so as the narrow side is pressed inside the v-shaped one. It creates a tight layer of unified roofcover.

These separate shingles are nailed to the constructive beams of the roof. There are usually 2-3 layers of shingles. In the vicinity of roof corners or other difficult spots, there are always three layers of shingles. This roof cover lasts around 15-20 years and might be prolonged by the use of special impregnates (18). To cover the roof according to historical method one would need a hand of a skilled craftsman. However, a thorough analysis of mechanisms functioning at this type of roof cover might come in handy when coming up with new ideas for a contemporary roof cover. For instance, the fact that wooden shingles with the fist contact with rainwater resize and become even more tight, thick and consequently let even less rainwater in. Such roofcover type has also one important advantage – shingles are very small modules – therefore they might be shaped with a lot of liberty.

In Upper Lusatia, just as in country architecture in general –materials used most frequently were these most accessible on the site. Fortunately, in Sudeten, slates could easily be found. It was used not only to cover the roof but also for facades since its durability provided it with around 70 years life span.



Fig. 41. Examples of various traditional types of roof cover for umgebinde houses. From the left: slates and ceramic tiles [Author's photographs].

A well-known material for roof cover is common ground. The idea of green roof is, in this light, not such modern, as we might think it is. Such historical green roofs have been used for many years. For example, houses localized on steep hills had parts of their floors covered underground. It was a method for insulating some parts of the house or using it as a basement. This aspect of uncommon roof cover might be also taken into consideration when designing the new umgebinde house, since green roof does provide many benefits. It aids in keeping the optimal moisture and temperature inside the house and minimalizes losses of energy needed for heating or cooling of the building (6).

2.3.2.Wall

This part of the building is especially characteristic in Upper Lusatia houses. Umgebinde structure allows construction of the wall to be independent of the bearing role that is taken over by constructive wooden pillars. It could therefore be lighter and thinner.

The origin of the umgebinde structure is not yet fully explained. Some researchers try to lead it to woven walls (ściany plecione) that needed pillars due to their feeble structure. Maybe these walls in time have turned into small

wooden sticks covered with clay-hay mixture and later into timber framing preserving corner pillars supporting upper floors (18). This theory is even more probable due to the fact that woven walls did appear in Upper Lusatia.

In order to protect these feeble walls, a bitumen slate was used as a cover – it is still popular as a decorative detail. Climbing plants covering facades might fulfill a similar protecting role. They reduce the influence of weather and create an acoustic barrier. They additionally provide decorative elements that correspond to natural colors of umgebinde houses.

2.3.3. Door

Entrance to a typical umgebinde house is usually localized centrally in the longer wall.

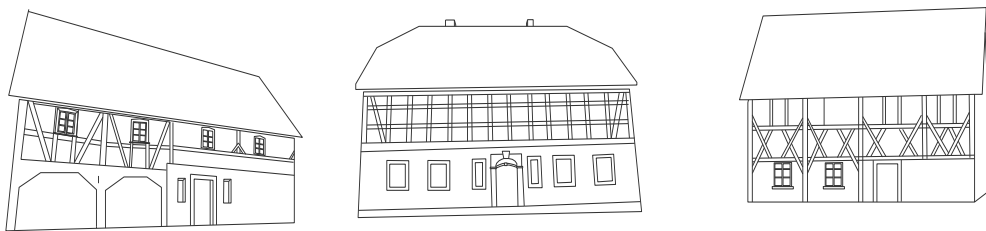

Fig.42. A scheme illustrating localisation of door in umgebinde houses [Author's scheme]

Entrance to a typical umgeginde house is marked by decorative door frame flanked by two small windows. Sometimes the door frame was additionally marked by stone portal.



Fig.43. Examples of entrances to typical umgebinde houses [Autho's photographs]

2.3.4.Window

Among most characteristic features of umgebinde windows are 4 or 6 fold partitions. Sometimes windows were equipped in 2 sets of shutters – summer and winter ones.



Fig.44.Examples of windows in typical umgebinde houses [Author's schemes]

2.3.5. Slab

As it is stated in Ignacy Tłoczek's *Polskie Budownictwo Drewniane* (Wrocław 1980), we may observe bigger and bigger spans with the use of less and less wooden material (18). Historical wooden slabs had great acoustic qualities due to big diameters of wooden logs. Modern wooden slabs thanks to its multilayered structure also have great acoustic qualities, therefore they may be successfully applied in the design of the new house.

2.3.6. Heating System

Traditional heating systems using chimney have been the result of a yearlong evolution. Despite changes in the form of heating source it has always had central area of the house with the direct access from the kitchen. Walls of the chimney have heated upper floors. The idea of placing a heat source in the central area of the house minimalized losses of precious heat in historical houses. This idea may successfully be explored in a contemporary house design.

2.3.7. Cellar/Basement

Cellar does appear relatively late in the process of development of an umgebinde house. It has frequently been a separate structure outside the house in a form of underground storage for food. In mountain regions it more often was connected with the house, because it was frequently localized in the sloping hillside adjacent to the house. A cellar was also often a space that filled foundation walls. Nowadays food is accessible in stores, therefore need for vast storages is limited to small vine basements etc.

On the designed site there is however a slope that may be a far reminiscence of traditional cellar. It is, however, not the necessary part of a building.

2.3.8. Detail

Decorative elements have been restricted to strictly utilitarian cuts or carvings of the constructive elements (17). This functionality of the decorative detail should also be continued in more contemporary form of houses in the region. The most characteristic decorative elements in Upper Lusatia are these directly connected with umgebinde structure such as constructive pillars, beams and profiles of the supporting beams or wooden pegs. These constructive elements altogether created decorative patterns of construction such as st. Andrew's crosses (20). The part of the house usually very rich in detail was a gable wall (*ściana szczytowa*) that was treated as a kind of visit card of the house. It was covered with carved wood or slates.



Fig.45. Various types of decoration of gable walls in umgebinde houses [Author's photos]

Details of the building were important for the owners of houses since they reflected financial, and thus social, status of its dwellers. Polish houses do have more modest details than the ones on the German side of the border. Most common Polish decorative motive was a simple boarding (deskowanie) with a decorative endings. Massive timber walls were usually deprived of detailing. Only window frames did have decorative carvings or incrusted shutters (20).

More decorations of the facades could be noticed on the upper floor – the structural beams have usually been painted in dark colors that contrasted with white fields in between (20).



Fig.46. Examples of detailing [Author's photos]

2.4. Traditional Building Materials

The most basic material for a country house is wood. It is not surprising since it is easy to obtain and transport, does resist to biological and atmospherical influence and its relation of weight to durability has no counterpart. It is also (what might be surprising) very resilient to fire (18).

Depending on time, region and other less important factors – nearly all parts of a tree might be used for constructive purposes – oval or square sections of logs are cut out of the trunk, short fragments are used for shingles, thin sticks, in turn, for filling the fields between timber framing, bark is used as insulation (17). It might therefore be said that any kind of wood used in a country house is in agreement with building tradition in Poland.

Wood obtained from various species of trees and various parts of the same tree has got different qualities. Among coniferous trees (iglaste) - the best type of wood is larch. Among hardwood (liściaste) such species as ash, beech, sycamore, rab, elm (jesion, buk, jawor, rab, wiąz) were used for finishing but the most valued type of wood was oak (dąb) with its high resistance to grinding (ścieranie), dampness etc. and durability that increases when wood is put into contact with water. This type of wood was mainly used for substructure, constructive frames, or pegs connecting important nodes (15).

From time immemorial, wood was a basic building material. Methods for its treatment were passed from generation to generation. For over 120 years, architectural landscape in Poland was shaped by local tradition mixed with stylistic trends from surrounding countries. These trends were mostly forced by construction law. In Prussia, for instance, the policy of fire protection regulations aimed at eliminating wood and replacing it with stone, brick and other fire-proof materials (i.e. in 1799 a regulation that prohibited massive wooden structure was ordered). New regulations were based on lowering tax for not-wooden building materials and aimed at separating houses from sheds and other buildings by a proper distance (15).

First world war resulted in great population loss – nearly 1/5 of citizens lost their houses, 12% of villages was completely demolished. Roads and rail tracks have been demolished in 80%, bridges in 92%, not to mention the results of war for the industrial development and agriculture. The biggest demolition concerned villages and small towns (15). It is therefore not surprising that the after war rebuilding was mainly done with the use of easily accessible wood. Many researchers claim that timber framing has become so popular in those hard times due to the fact that it was a construction relatively well known and easy to master(15).

After the second world war many prefabricated building materials were used when raising houses in cities. These however were completely not suitable for villages. Consequently, again, wood was popular in the countryside.

In the contemporary design of a house, wood is appreciated for its esthetic qualities. When additionally it is treated with ecological varnishes and paints it becomes durable building material also for the modern houses.

Stone

The most commonly used type of stone for umgebinde houses was slate. Dark grey or even slightly green stones easily slice into thin slates therefore they were used for ground, wall or roof covers. The weight and

probability of containing radioactive radon are the main disadvantages of this material.

Another sort of stones used when raising houses were common fieldstones removed from fields while cultivating the land. Such stones are usually used for foundations.

Earth

Earth is easy to obtain and very cheap, sometimes it is the only accessible building material. Shaped in bricks, dried in the sun, has excellent insulating qualities. Houses that are built with the aid of such bricks, when it is done properly, are very resistant to fire and pests. They help to keep constant temperature and moisture inside the house and require only about 2% of the energy used to build the same house out of concrete.

Even though, in order to produce an earthen brick one might use nearly all types of earth. The best mixture contains 75% of sands and minimum of 10% of clay (12). Clay contained in the ground might also be used as an ingredient of various other building materials such as plasters.

Clay

It may be encountered as an ingredient of the ground in the whole country. Thanks to its common appearance in local grounds of Worek turowski region, it has been widely used as a basic building material in various regions. It is easy to find examples of various clay-buildings such as houses. Building with clay satisfies all the basic requirements of a modern house. Clay is characterized by a high level of ability to accommodate heat, insulate sounds and balance level of moisture in the building. It is also well known for its ability to preserve wood and when accompanied by such ingredients as chaff (sieczka) tailings (plewy) and dried heather (suchy wrzos) may receive even better insulating qualities than brick. When using clay, one may reduce level of radioactivity of the building (11).

Linoleim

Linoleim is produced of solidified linseed oil (linoxyn), pine rosin, ground cork dust, wood flour and mineral fillers such as calcium carbonate, most commonly on a burlap or canvas. (12). It has got all the advantages of PVC, however it is a natural material. It should be placed on a dried flat surface otherwise it might rotten. It should not be cleaned with chemical detergents, but natural ones especially those used for wood (12).

Grass

Considering the annual growth of hays and corns in Poland - it is easily accessible building material. Its new supply comes in every harvest season. It has been used as insulating material and roof cover for years. The best type

used for building purposes is rye (better than oats, barley, wheat) since it has the longest stalks and it is the most resistant to weather conditions (12).

As we may read in *Zmiana Studium Uwarunkowań i Kierunków Zagospodarowania Przestrzennego Miasta i Gminy Bogatynia*, corns make 85,15% of the total cultivated area in the region (1145 ha). Among that, oats account for 47,24% and rye - 18,82% (H). That is the main reason, why including this building material in the design of the new house would be a well-grounded idea.

Natural paints and varnishes

Delicate colors, subtle smells and unpolluted environment are only some advantages of natural paints. Waxes and varnishes are most often produced from various parts of plants, such as: madder root (korzeń marzanny), oak bark (kora dębu), birch leaves, chamomile and crocus flowers and walnuts. Natural products supply also other ingredients of paints giving them most pleasant smells – those are – bee waxes, flower and herb aromas.

Linen oil is the most universal impregnate for both interior and exterior. It is an irreplaceable protection against water – especially for wood (12).

Gypsum/Plaster (gips)

Products created with this material are ecologically clean. They have the lowest radioactivity rate among all the building materials. They also aid in creating a perfect microclimate in the interior. The process of both producing and recycling of gypsum does not influence the environment. When it comes to the synthetic gypsum it even in a way cleans up the environment (11).

2.5. Summary

Ignacy Tłoczek draws our attention to a certain characteristics of country houses that distinguishes them from city houses. Their functional layout must be enriched in working space sometimes followed by a storage (23). Additionally when there is no possibility to connect the household to sewage and water systems, there is a need to provide space for proper mechanisms or installations that could make it independent of the external sources of water or energy supply.

Undoubtedly the issues discussed in the above chapter are guidelines for the design of the new house that will be described in the next chapter.

Chapter Three

In order to compile an analysis of the present state of Urban context of the analysed region, three basic documents have been taken into consideration: *Studium Zagospodarowania Przestrzennego Pogranicza Polsko-Czeskiego* (J), *Studiumh Uwarunkowań I kierunków zagospodarowania przestrzennego Miasta I Gminy Bogatynia* (H), and *Miejscowy Plan zagospodarowania Przestrzennego Miasta I Gminy Bogatynia* (K).

Communication (System of transportation)

Polish-Czech borderline is characterized by a well-developed communication system. The net of rail and ground tracks places this region high in both Polish and Czech statistics (J).

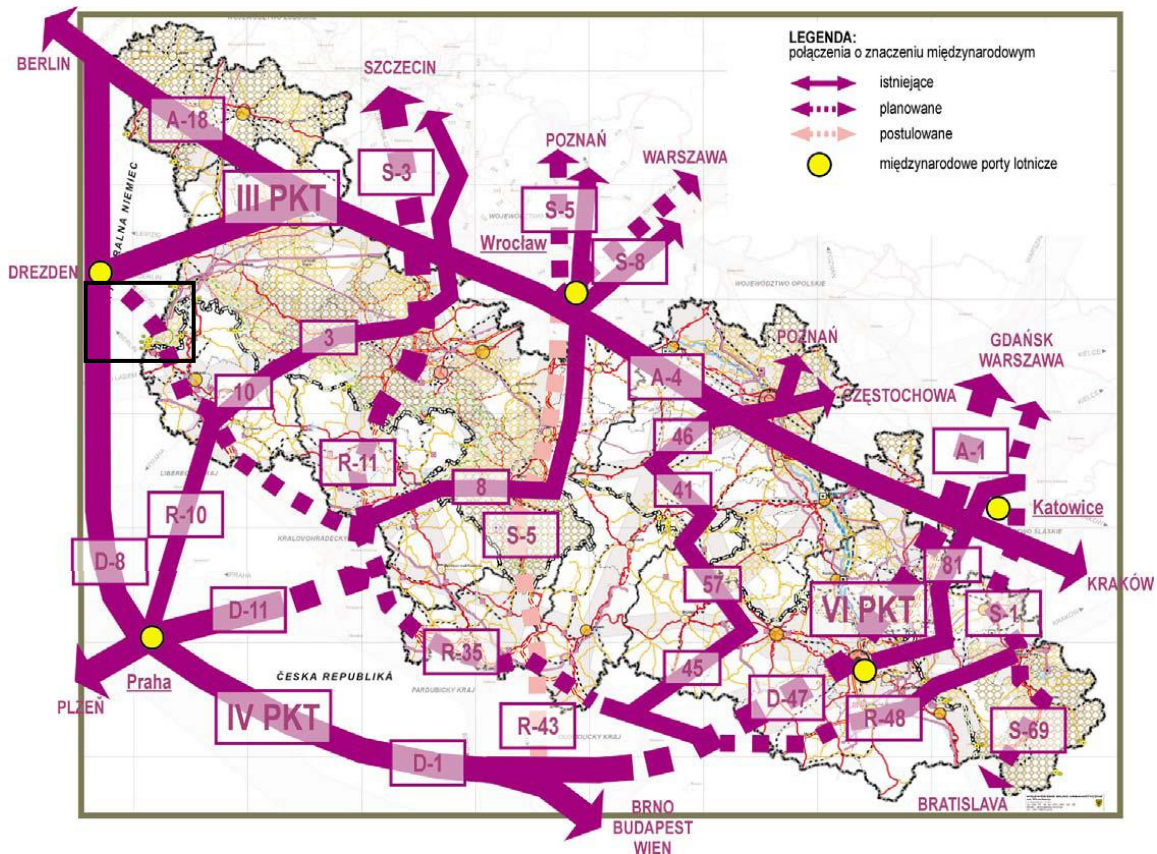

Fig.47. A map illustrating the net of roads in the Polish part of Polish-Czech borderland (J)

The Polish-Czech borderland is connected via A4/A-18/DK-18/E-40/E-36 and DK4/94, E-22 and E65, E75 and E55 roads. This net of roads will also be additionally connected with newly designed B18, R-35 (J)

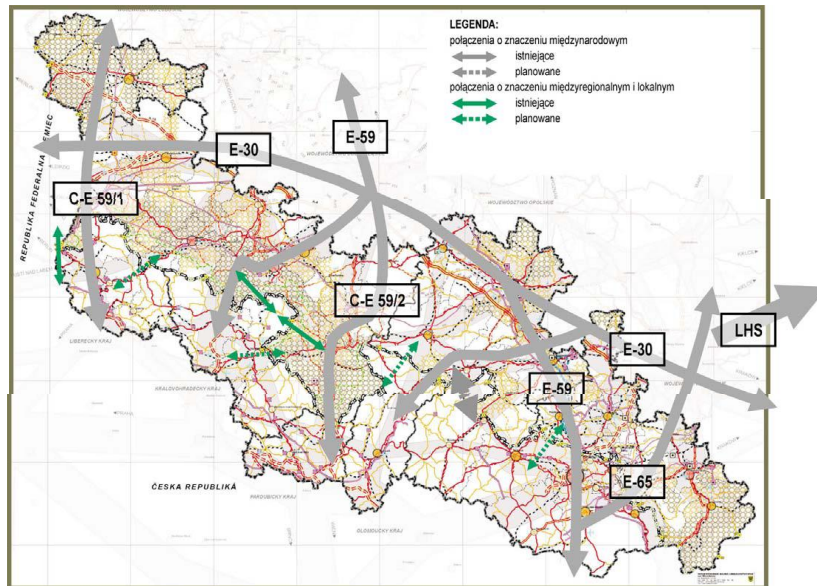

Fig. 48. A map illustrating the net of rail tracks in the Polish side of Polish-Czech borderline (J)

Industry

The area of (Bogatynia) and (Turoszów) is an industrial monoculture of coalmine energy production. The neighbouring types of industry are:

- Chemical and glazing industry – Liberec, Karvina, Bruntal, Jabloniec nad Nisou
- Wood-paper industry – Kłocko, Wałbrzych, Ziębice, Kapkowice, Głuchotaży, Sumperek, Karvina, Havirou, Peskov, Turnov (J)

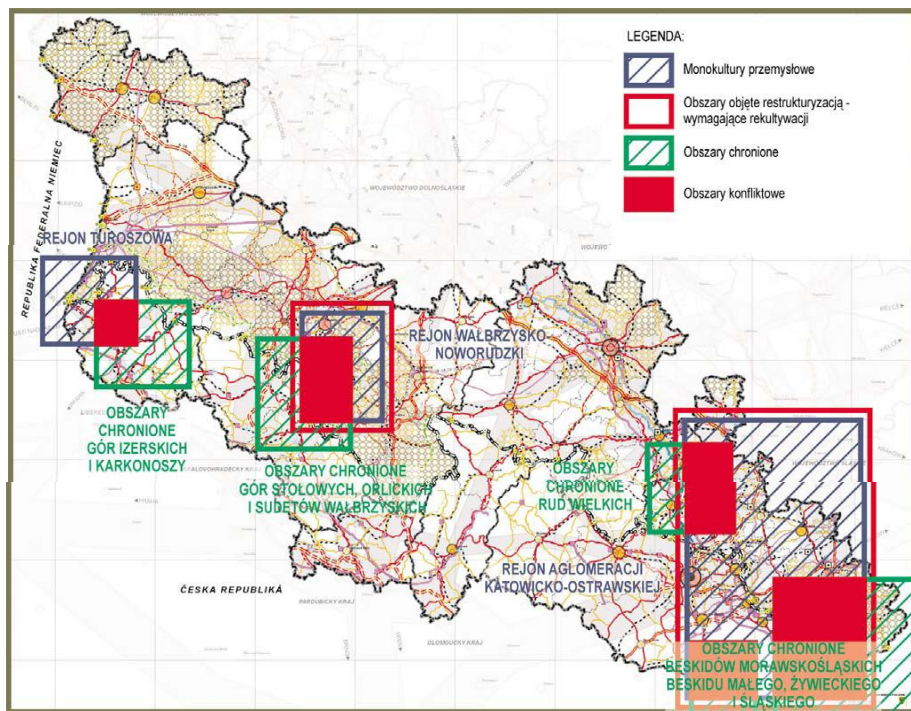

Fig. 49. A map illustrating industrial regions of the Polish-Czech borderland (J).

Environment and Leisure

The most popular trans-border projects (projekty transgraniczne) are, among others, *Umgebndeland* – complex revitalization of historical houses and urban outskirts.

Studium Uwarunkowań [...] does say that all the new design projects should lead to an improvement of civilization standards. Strategic Areas developed by local authorities concentrate on housing, preservation of local cultural heritage and revitalization of historical buildings altogether with increasing attractiveness of touristic offer (H). In the said document, we also find a chapter devoted to supporting local companies and small business (H). The newly designed house will therefore need to include space for a workplace.

According to *Studium*, analyzed region is a part of the area under the direct legal protection of the conservator. Wyszaków is in the protected zone, where preservation of urban structure is obligatory as well as keeping the historical form of buildings (H).

As neighbouring villages are one urban organism - also in Maxdorf (Wyszaków) and Friedreich (Wolanów) recreating historical urban structure with cubatures corresponding to umgebnde houses should be a priority. As it is stated in *Studium* – new buildings should be designed with respect to iconography and other historical sources it should also correspond with historical buildings. Traditional building techniques should be used when raising new buildings(H).

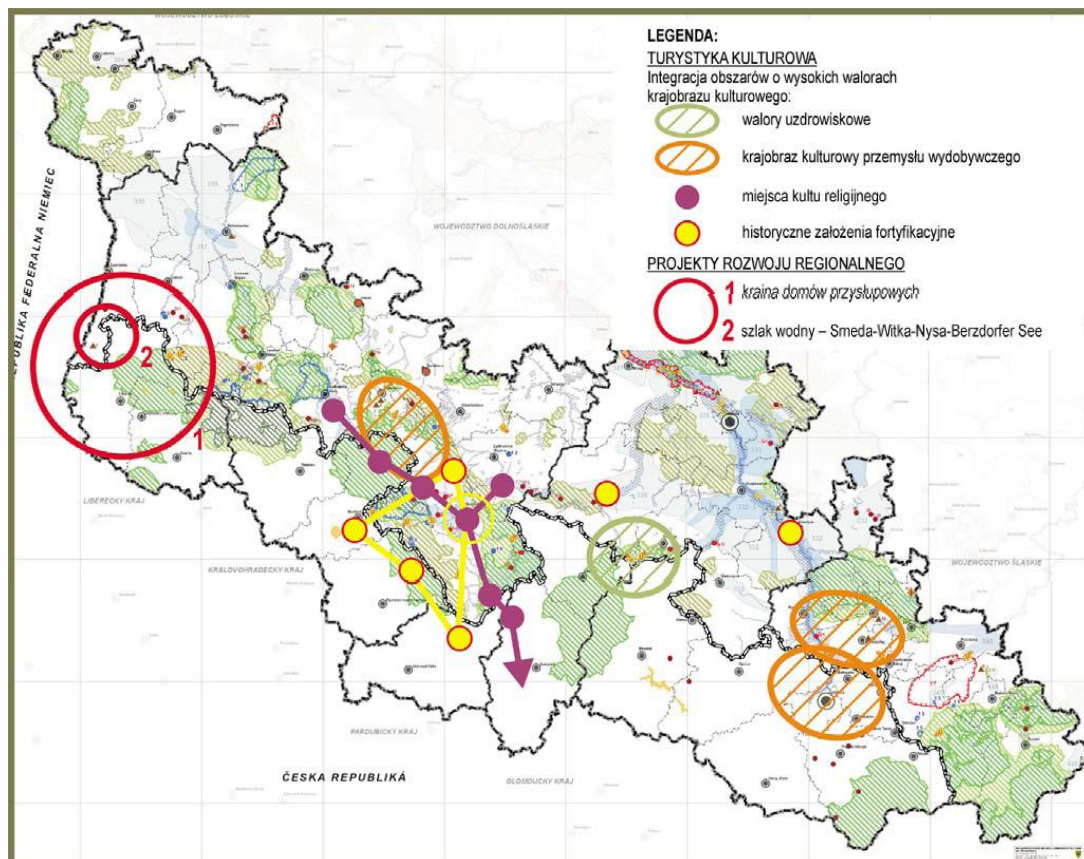

Fig.50. A map illustrating tourist attractions of the Polish – Czech borderland (J)

Studium pinpoints new plans for increasing attractiveness of the region. One of them is creating a touristic path leading via Maxdorf (Wyszków) (H). This track aims at presenting the most attractive views of the region. Thanks to already existing PTTK tracks, tourists will be able to freely shorten or prolong the length of their walks and end it in Bogatynia or other towns in the region. There is also a possibility of opening a touristic border crossing between Weigsdorf and Visnova.

Among other attractions there are numerous archeological stands from Middle Ages that are not yet included in the list of conservator – in Weigsdorf (Wigancice Żytawskie) and Friedreich (Wolanów) (8). Altogether – there are nine such stands in Friedreich (Wolanów) and four in Weigsdorf (Wigancice Żytawskie). Only this reason is sufficient to open another touristic track via these villages.

Another interesting information about Maxdorf, Friedreich, Weigsdorf area is the fact that the soil around these three villages is the best in the region. The percentage of class I-IV soil in the said villages is respectively 97,46%, 96,46% and 93,38 % (J). It is similar when discussing greenery of the best (1-3) class – it amounts to 60,65%, 73,36% and 58,02% respectively (J). As it might be observed on the map below, there are numerous parks and reservation parks in the vicinity of the analyzed region.

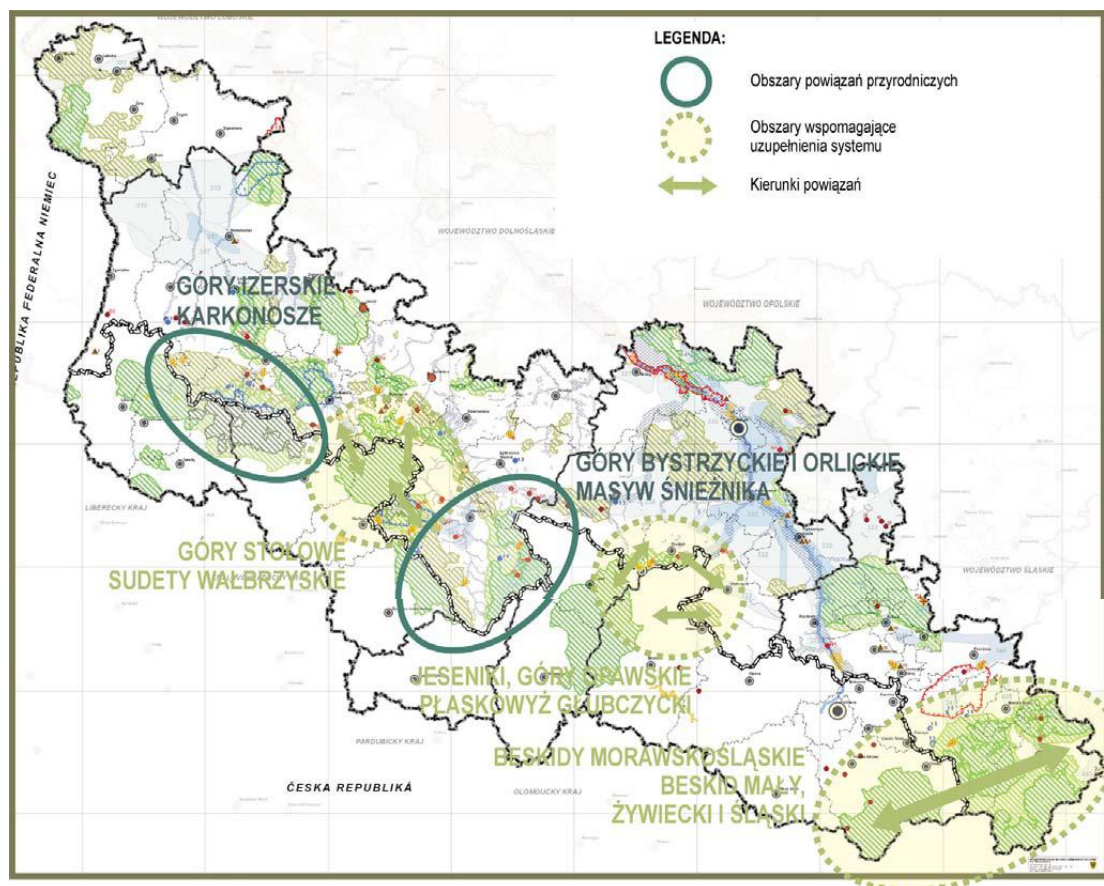

Fig.51. A map illustrating the areas of best environmental qualities in the Polish-Czech borderland. (J)

MPZP does include protection of regions with high environmental qualities. It does also put emphasis on raising ecological awareness of the local society by eco-education leading to a sense of responsibility for local environment (H).

Undoubtedly, the use of most ecological technologies in the newly designed house does fit into this tendency. It is worth to mention that in Weigsdorf (Wigancice Żytawskie) there are two out of three natural monuments in the (Bogatynia) district. These are oak (Weigsdorf 43, registered under the number 295) and linden (Weigsdorf 43, registered under the number 292) (K).

Additionally in the analyzed region – there are areas that deserve protection due to precious flora and fauna species (H). These regions are especially woods by the stream in Friedreich (Wolanów) and woods north to Maxdorf (Wyszków). In the whole district, there is a regulation that aims at recreating the percentage of hardwood trees in local forests – especially oak and beech(H).

In MPZP, we may also read about protection of existing parks and gardens (K) – it is a direct reason why in the designed house a lot of attention is also given to the site plan.

Water

The district of Bogatynia is being supplied in water by water supply network. All the towns in district of Bogatynia are connected to this system. Additionally, in Friedreich (Wolanów) there is a water intake. Friedreich is supplied by this intake and Maxdorf (Wyszków) by the one in Posada (H). There are also nine covered drink-water sources and fifty two deep wells in the whole district (H).

Despite the fact that the newly designed house may clearly be connected to this water supply system, it has been designed as completely independent from both – water and sewage systems. In the design, the complete technology of water and sewage maintenance has been described via schemes and descriptions.

Many villages in the district of Bogatynia are still not connected to the public sewage system (H). It is prohibited to remove sewage to the ground, however it is allowed to clean it in ecological treatment points – that is why in the design such an installation has been provided.

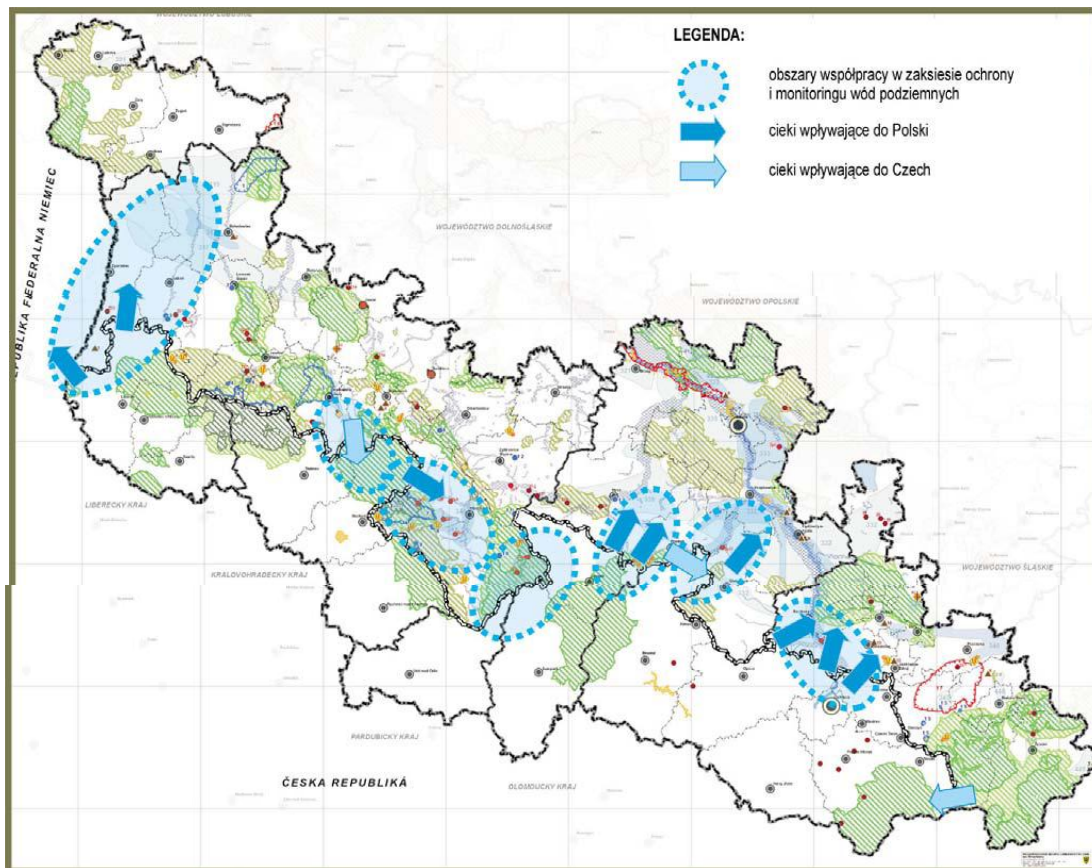

Fig.52. A map illustrating water supply in the Polish part of Polish-Czech borderland (J).

Density of Population

According to data from January 2006 there are 40 dwellers in Friedreich (Wolanów) and 117 in Maxdorf (H). These villages are least populated in the district of Bogatynia.

People in Lower Silesia, in general, are a greying society (*starzejące społeczeństwo*), however the percentage of young people in villages is much higher which all in all gives Bogatynia the status of a young village.

Demographic prognosis assume the need of new houses for growing population on the countryside (H). Therefore a site localized in the village (Weigsdorf) has been selected for the design of the modern *umgebinde* house

Summary

Studium does indicate the necessity of creating masterplans (*miejscowe plany zagospodarowania*) for Weigsdorf (Wigancice Żytawskie), Maxdorf (Wyszków) Friedreich (Wolanów). In *Studium* we also read that this region is supposed to be kept as woods and agricultural fields – not to be turned into building sites (*działki budowlane*) (H).

That is the main reason why the author has decided to localize the designed building site in Weigsdorf (Wigancice). This village has every chance to become a model urban outset however realized in new cubatures.

Among many general guidelines – we may read in *MPZP* that among the protected cultural heritage, we may find such traditional urban setups as Weigsdorf – including layout of buildings on the site, the scale of buildings, architecture, architectural detail, water, (cieki wodne) and roads.

Set of clear guidelines, contained in *MPZP*, concerning urban issues in the region, directly touches upon analysed villages. It states that the degraded elements such as regional architecture should be recreated in new contemporary forms. Detailed guidelines, concerning houses, state that the form ought to be simple and concise with additive buildings at the right angle or on the long axis of the building. Houses should also use elements of traditional umgebände construction (K). Thus construction of the newly designed house does follow these guidelines and goes one step further – to reinterpretation of both – traditional building techniques and natural materials.

According to the said guidelines, the roof should be symmetrical and sloped at the angle of 45-55 degrees (K). *MPZP* suggests using ceramic tiles as a roof cover, however in the newly designed house, the author has selected the material that additionally gives energetical benefits. Even though many traditional house details are allowed, they are not obligatory, thus the author has dropped them for the benefit of emphasizing traditional construction.

Another element that follows guidelines of *MPZP* is the fence. Simple wooden sticks were usually used as a basic material. In the design of the new site plan, the author has also used the difference in ground level between various parts of the site. It divided the terrain without the need for using the fence.

3.2 Site Plan

MPZP for the district of Bogatynia does allow localization of new houses in the vicinity of coalmine area, but only when some certain conditions are fulfilled. One of them is obtaining permission from the proper office (Okręgowy Urząd Górniczy) and Turów coalmine (K). Other preconditions are already fulfilled for the selected site in Weigsdorf, therefore the author has decided to fill the historical site plan with new cubatures.

Southern part of the site has been planned as a garden – in order to preserve existing trees – they provide shadow in the summer. They reduce the excess of sunshine, however, as they are hardwood trees, they loose leaves in wintertime and then allow maximum sunshine to interiors. The South - Western facade of the house is planned as covered with climbing plants that would insulate the wall in winter and provide shadow in summer.

In the Northern part of the site, the author has placed coniferous trees in order to protect the house from wind – both in winter and in summertime.

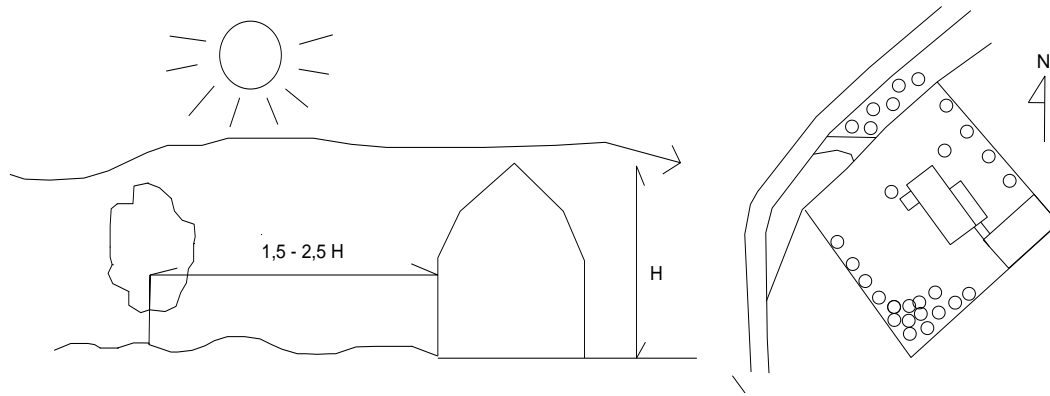

Fig.53. A scheme illustrating the wind-protecting function of trees located in the Northern part of the site [Author's schemes].

The most effective localization of the wind-protecting trees is within a range of 1,5 – 2,5 times the height of the building (letter H on the schemes). In such a localization – the wind is being directed above the building. Making the wind partially go through the building makes this wind-protection much more effective (12).

Bearing in mind the level of sunlight within the day, daytime rooms have been localized on the Southern part of the house, whereas bedrooms and bathrooms have been localized on the Southern part.

3.3. Architectural project

Ideas are not solutions, therefore the design of the new house meant integrating all the interesting ideas into one solution adjusted to the needs of its dwellers. The house has been designed for the needs of a 4-member family (with the awareness of its' growth in time – future children)

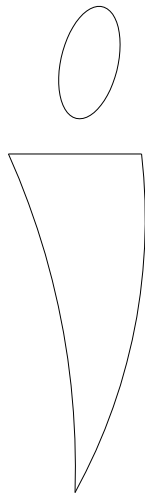

HE

Is a painter and needs a studio that could be as close as possible to his house – he likes to work in the evening or even during the night when inspired.

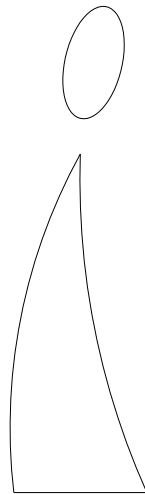

SHE

Is a writer and needs a quiet place in her house in order to work and take care of the family at the same time. She loves gardening.

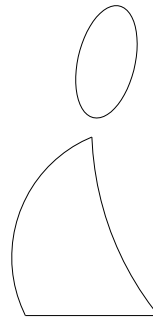

she

is a typical 10-year old. She needs her own room to explore her hobbies.

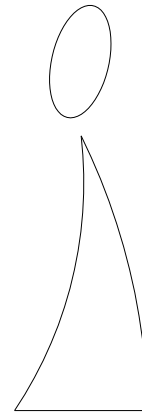

she

is a talented 13-year old pianist. She needs her own room and space for her piano.

THEY

Used to live in the city centre in Goerlitz therefore they look forward to moving into the countryside. They strongly identify with the region and want to live in the vicinity of cultural facilities, however they dream about a quiet place away from the noise and pollution.

Fig.54. A scheme illustrating the characteristics of the dwellers of the designed house (Author's schemes)

3.3.1. Concept of the house

A house is usually a long-term investment, therefore during the design process, the author has made an attempt at including future changes in the structure of the family (the inhabitants of the designed house).



Fig.55. A scheme illustrating functions of particular rooms – its' changes in time [author's schemes].

At the scheme above the author has schematically illustrated, what happens to the building in time. Following floor plans illustrate various possibilities for adopting interiors for given stages of the development of the family. The last one symbolically shows biodegradation of the building.

According to Polish norms, it is not yet obligatory, however it is a wise solution, to think about not only the cost of a building itself, but also about the cost of its demolition. This sort of regulations are already in use in some

European countries, therefore, when selecting building materials, the author has also taken into account the possibility and ease in utilization of building materials used to raise the house. Walls constructed in straw-bale will be utilized as fertilizer (straw) and fuel (wood). Foundation stones and clay will go back to the ecosystem (back to the ground probably). Wooden construction beams may be reused or burned for heating. The demolition cost will be minimalized because there will be no need of using specialized equipment – only solar panels will need to be utilized in a specialized manner. All the other elements may be utilized by owners of the house themselves.

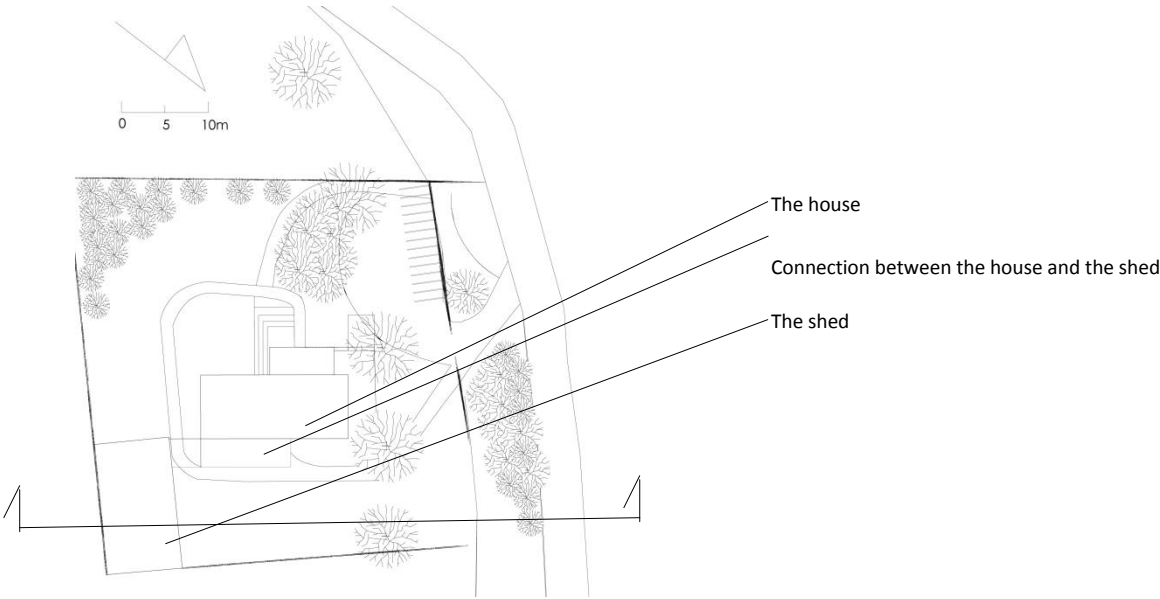

Fig.56. A scheme of the new design of the site plan [Author's schemes]

The plan above illustrates localization of the cubatures and greenery on the site. The section below does also show the underground elements of the siteplan. It shows the structure of the sewage treatment system underneath the lawn.



Fig. 57. Section of the site [Author's scheme]

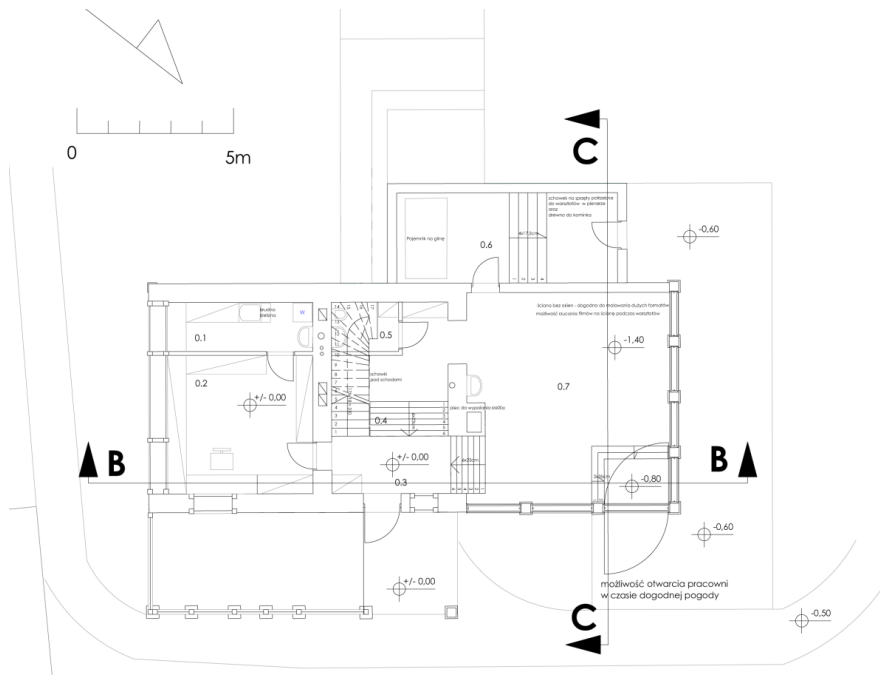

Fig.58. Level 0 floor plan [Author's scheme]

The ground floor houses workplace of both parents. There is also a laundry room with the container for dirty clothes that go down in a special shaft from bathrooms on upper floors. The entrance hall has been connected to a glazed winter garden.

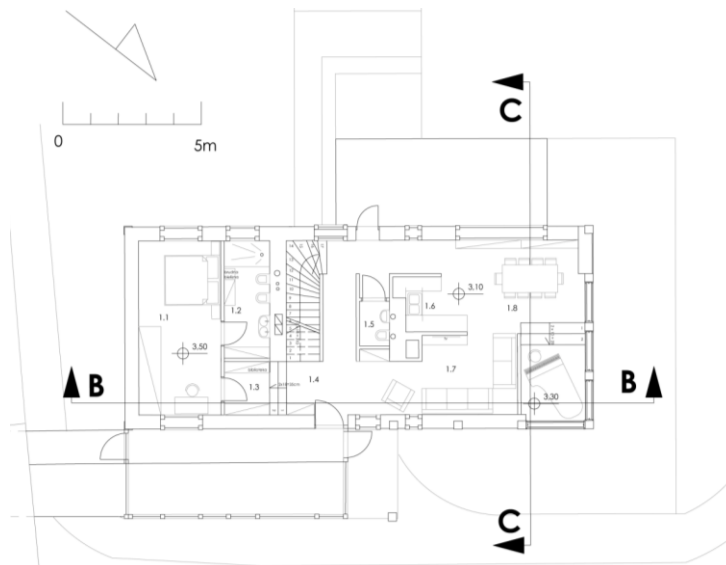

Fig.59. Level 1 floor plan [Author's scheme]

The first floor is an integrating area for the whole family but it is directly controlled by parents who also have their bathroom and bedroom on this floor. The living room and kitchen, separated from the night-zone by steps, is connected with the shed by a glazed corridor.

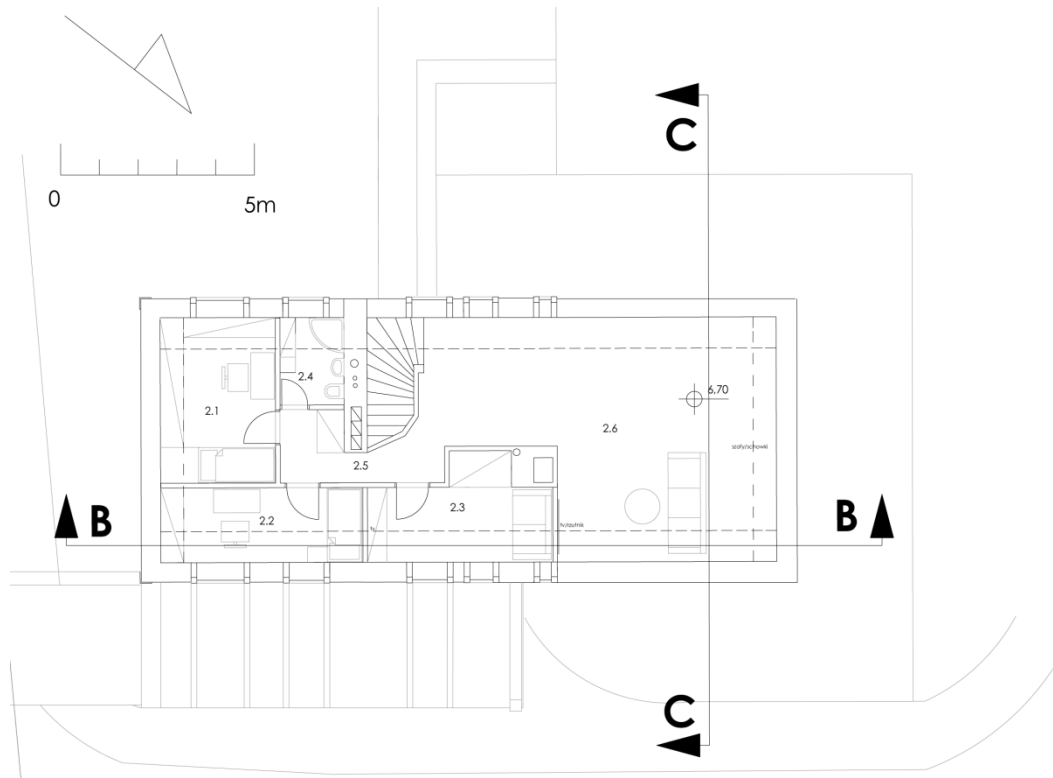

Fig.60. Level 2 floor plan [Author's schemes]

The attic has been completely adjusted to needs of children. There are two small rooms and a very big playground area (this solution serves integration not isolation). There is also another room for grandmother or a nanny that looks after children. These rooms are localized on the Southern side in order to provide optimal sunlight.

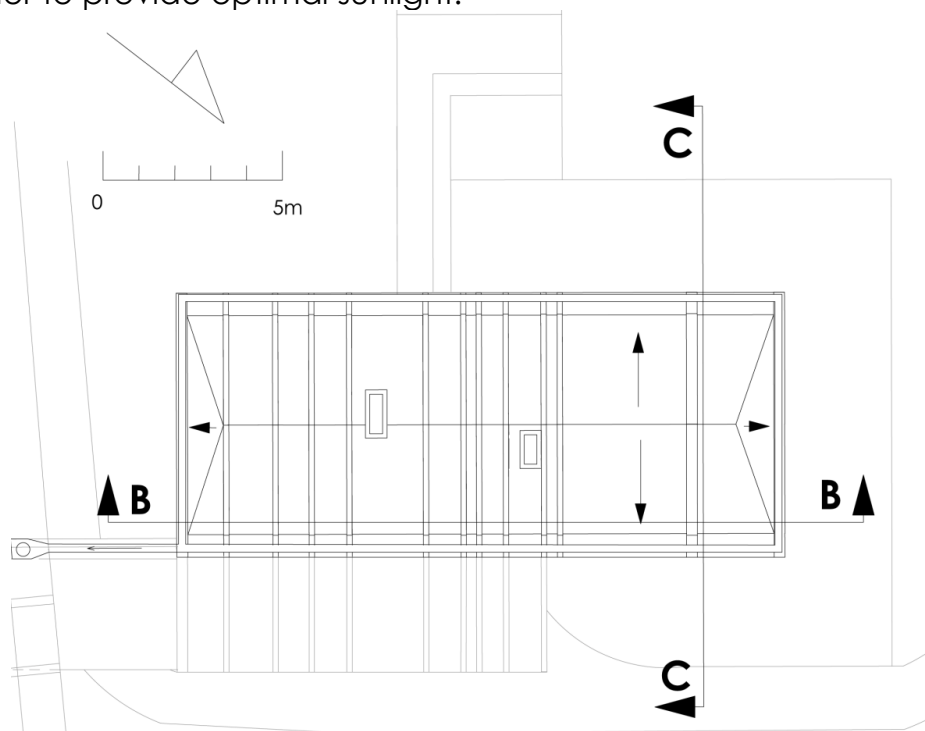
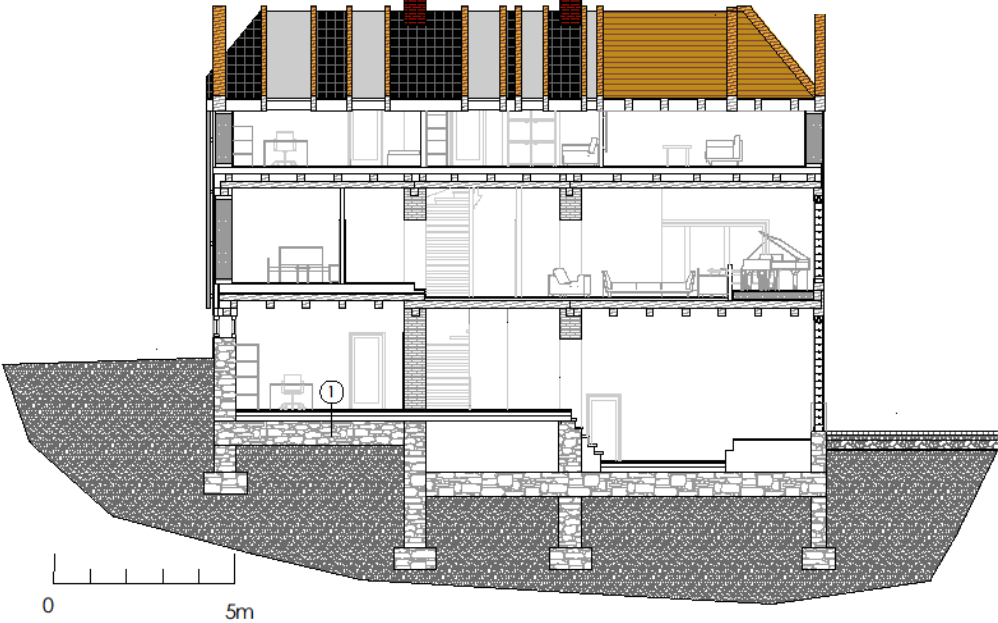

Fig. 61. The plan of the roof [Author's schemes]

The shape of the roof allows directing rainwater into the spouts connected to a container in the shed. There are two chimneys finishing the roof-walls. The Southern part of the roof is connected to Solar panels and the Northern part is covered in contemporary shingles adjusted in terms of sizes to facades.



Section B-B

Fig.62. Section B-B. [Author's schemes]

At the section above the author has depicted variety of constructions and materials used for the designed house. Different floor levels are an attempt at adjusting the house to the unevenness in the ground level. At the section below, the author has depicted the angle of slopes of the roof.

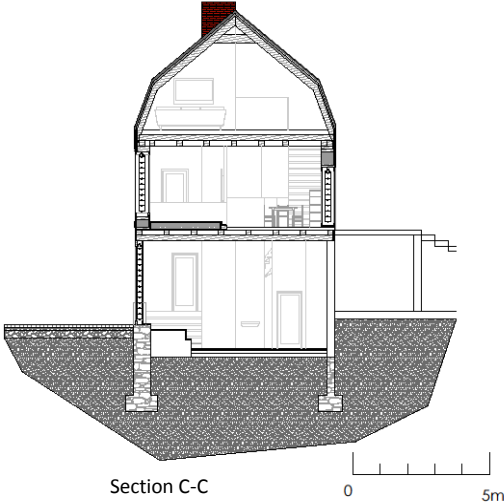

Section C-C

Fig.63. Section C-C [Author's scheme]

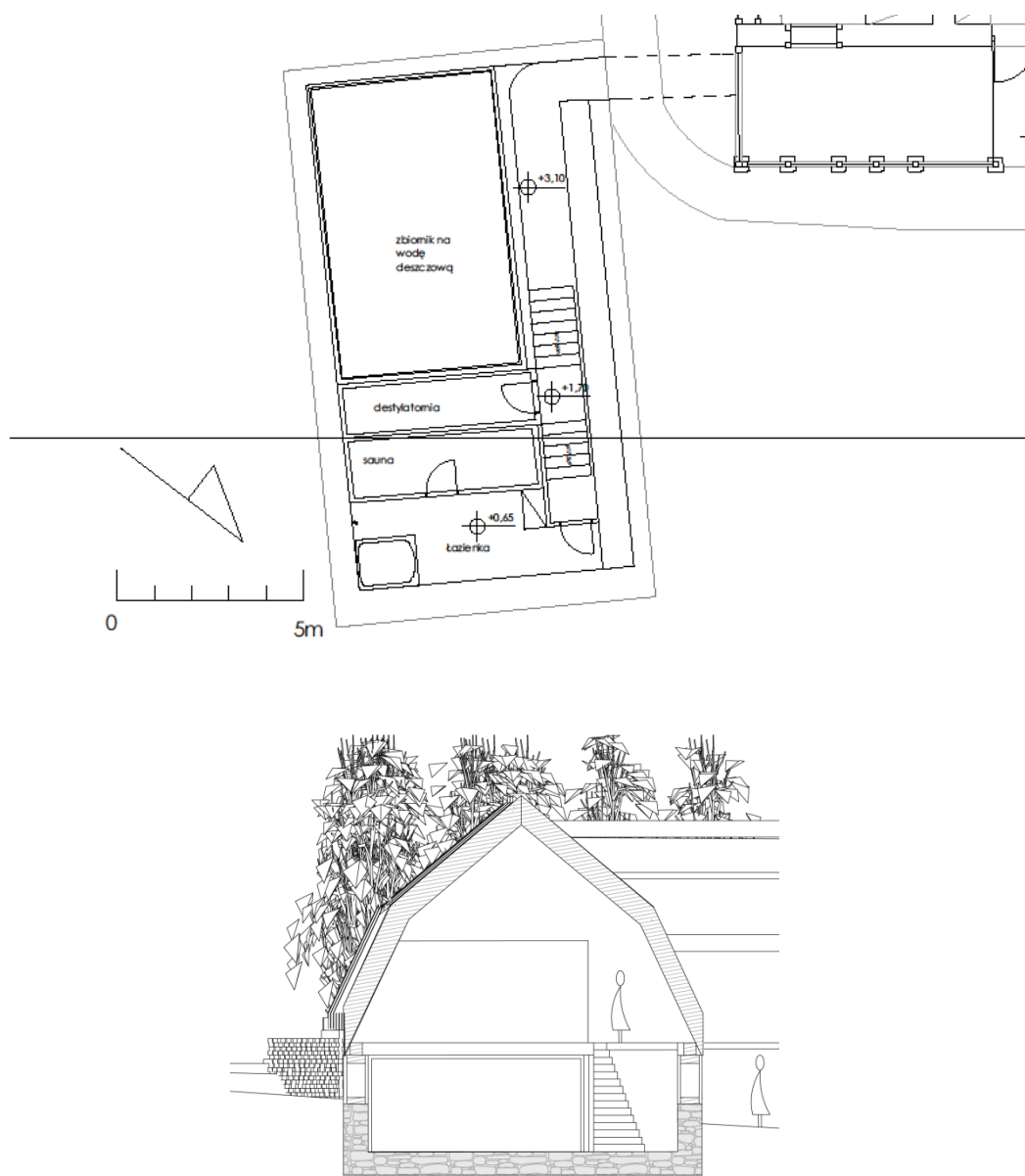

Fig.64. Floor plan and cross-section of the sched [Author's schemes].

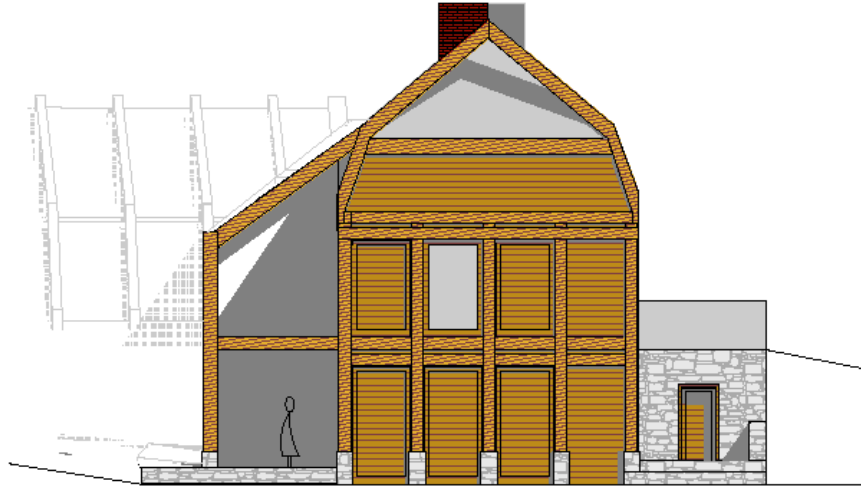

Fig.65. Northern facade [Author's scheme]

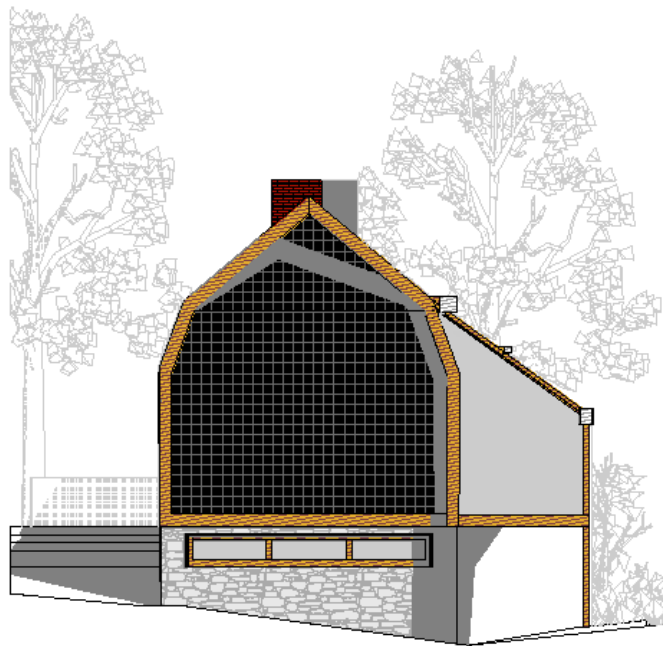

Fig.66. Southern facade [Author's scheme]

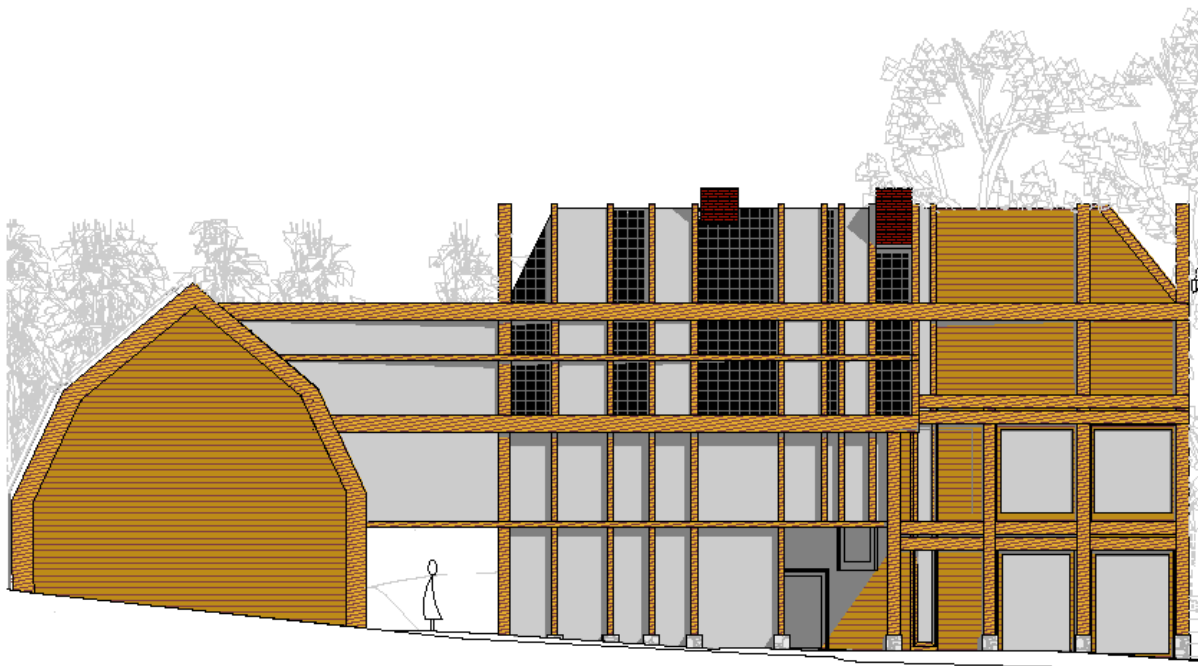

Fig.67. Eastern facade [Author's scheme]



Fig.68. Western facade [Author's scheme]

The direct inspiration for such functional solutions of the house were analogies to the last preserved house from Weigsdorf - Chata Kołodzieja. The scheme below illustrates the correlation between old and new functions.

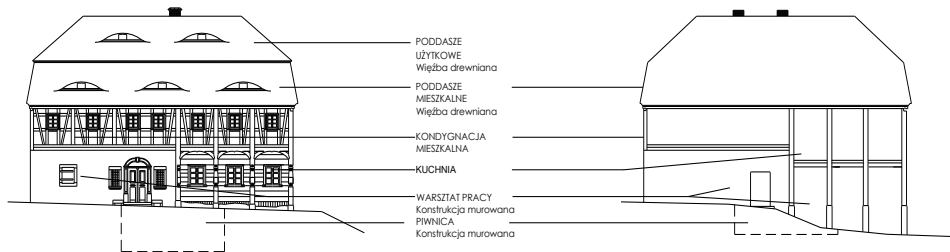

Fig. 69. Simplified scheme of the inspiration for functional solutions [Author's schemes]



Fig. 70. Functions in the interior of the house [Author's scheme]

For the purpose of the below comparison of European norms concerning floor plan area and floor plan area in the designed house show its relation to the average in the district of Bogatynia.

According to European norms – the average flat has 75-80 m², whereas for Bogatynia – it is only 58,10 m².

Average flat area per person accounts to 18,70 m² for district of Bogatynia, whereas European average is 25-30 m². Consequently, for the designed house, the ratio per person per room is 3,1 compared to normative 2,8 – 3 (H).

In the designed house - total floor area accounts to 304 m², that gives approximately 76 m² per person. Consequently – this ratio accounts to much more than the European average.

3.3.2. Selection of materials and technologies used in the design of the house

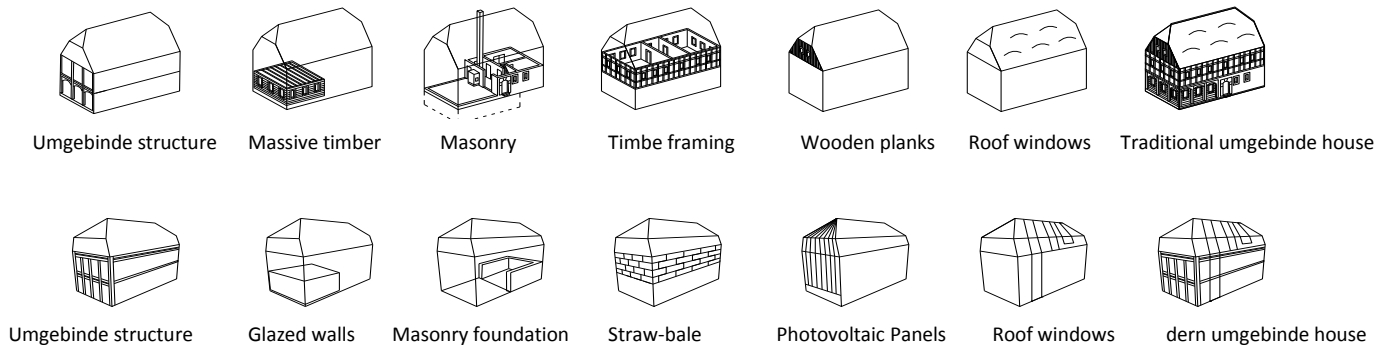

Fig.71. Comparison of the traditional building materials and solutions in the designed house [Author's scheme]

Construction

The author has discussed basic constructive elements on the scheme below.

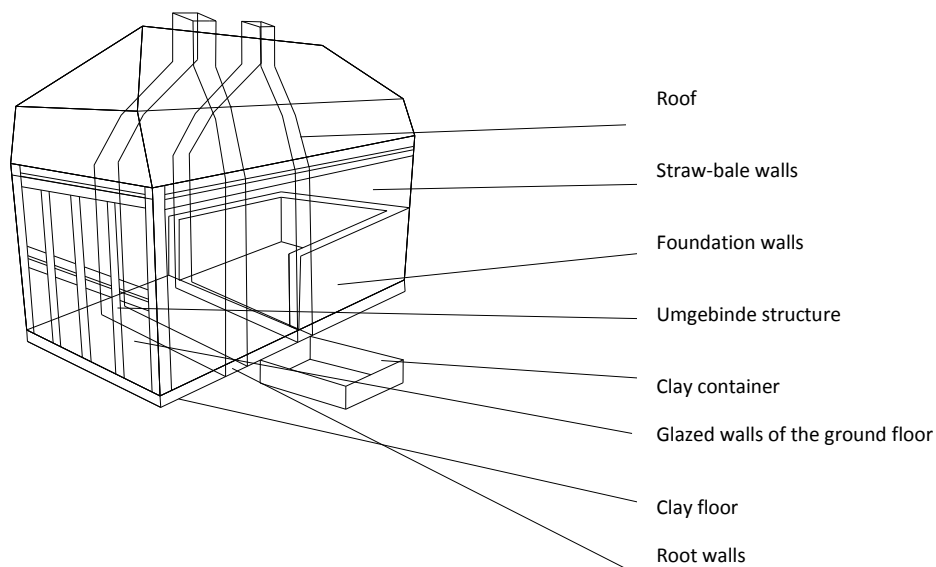

Fig.72. A scheme illustrating basic construction elements of the designed house [Author's scheme]

Foundation

The majority of foundation - functions at the same time as groundfloor walls. Thanks to adjusting the foundation grandfloor walls to the shape of terrain the house makes the use of earth as a natural insulation and building material. Foundation walls are made of local fieldstones that are placed on regular strip foundation calculated with regard to Polish norms. Minimal

thickness of foundation walls equals the width of walls (around 50 cm) Foundation walls underneath the constructive beams are elevated – around 50 cm above ground level. The plinth around the building is sloped outwards from the building in order to prevent rainwater from penetrating foundation.

Clay container

This container serves keeping sculpting clay in required conditions. Optimum for such clay is a humid cold container placed at the level of the ground. That is why in the designed house a container is localized in space underneath the staircase (without direct access to sunlight). Material used for building this container is a sand-clay-cement mixture prepared according to the PN-62/67 3801 norm.²

Floor

Clay floor has been designed for the new house. Underneath the floor itself, a layer of thick gravel is placed in order to prevent capillary water penetrating upper layers of the floor. The floor is insulated with loose perlite with 5% gypsum additive and consists of few layers of clay. The top coat is covered with linseed oil. After a thorough drying it might be polished with natural waxes. It is worth to mention that type of floor is realized properly, it does not have any of its popular defects such as: absorbtivity, looseness, fragility, dust. (L).



Fig.73. Examples of contemporary clay floors impregnated with natural waxes and linseed oil.

If users of the designed house would decide to do the same flooring on the upper floors (on level 1 and 2 the author has proposed wooden flooring and ceramics) between constructive beams of the slab – one would need to insert insulation (loose perlite and 5% gypsum mixed with light clay) and then insulating foil only then layers of clay floor.

In the designed house, the author has proposed floor heating. The pipes are placed within the lower layers of clay floor. The scheme below illustrates the localization of heating within the floor.

² Polish norm concerning clay and mixtures containing clay as building material.

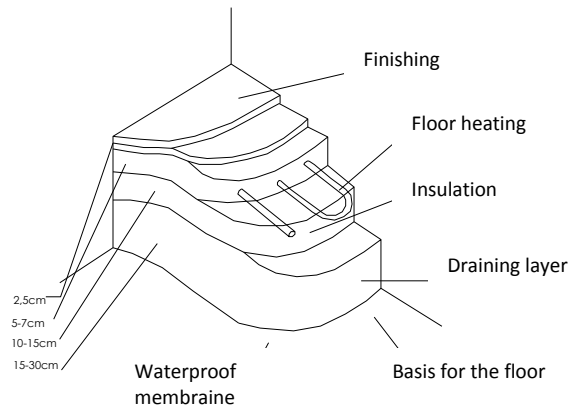

Fig.74. A scheme of a clay floor [Author's scheme]

Using clay for flooring is advisable due to its antiseptic qualities. Reduction of dust is especially helpful for allergies.

Root walls

Important constructive elements (including heating pipes) are root walls. They are built in bricks as thick walls based on the foundation and finished with chimneys. They may not be built out of clay only, since they serve as construction. However, clay may be used for its finishing.

Ground floor walls

Ground floor walls are composed of not only foundation walls, but also of constructive beams and a system of wooden blinds placed in between glass. This system is a direct reminiscence of massive timber structure. Especially when blinds are closed they resemble wooden logs. The scheme below illustrates functioning of these blinds.

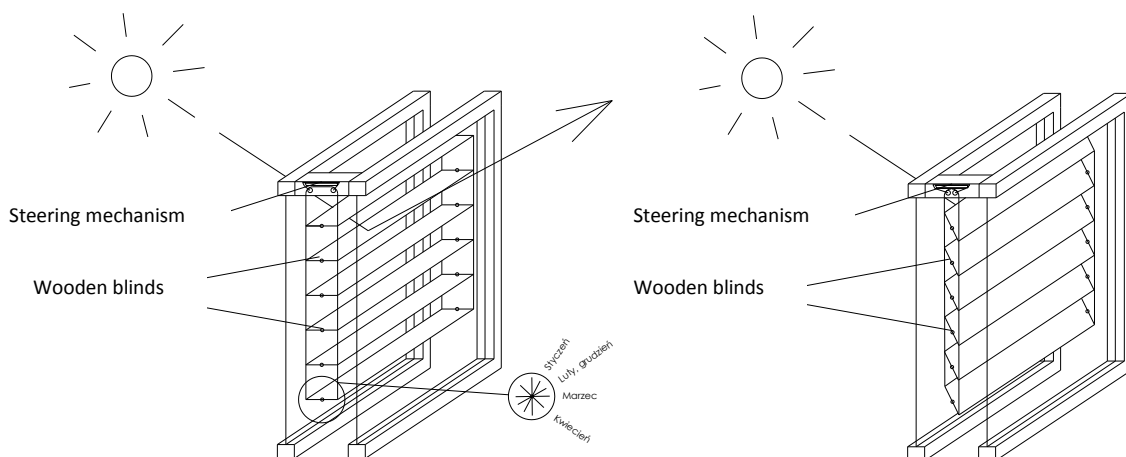

Fig. 75. A scheme of the wooden blinds' mechanism [Author's schemes]



Fig.76. Visualization of the glazed part of ground floor walls [Author's work]

Walls on the Upper Floors

The idea of long-beamed umgebinde construction is visible on the facades. It stiffens the construction and supports the roof – walls are thus independent of this structure and do not need to bear the load. The upper floor walls are raised in a technology called straw-bale. A pressed straw is placed between wooden frames. It guarantees low building costs (easy to raise, cheap materials – wood, straw) and possibility of placing the heating within the outer layer of clay finishing.

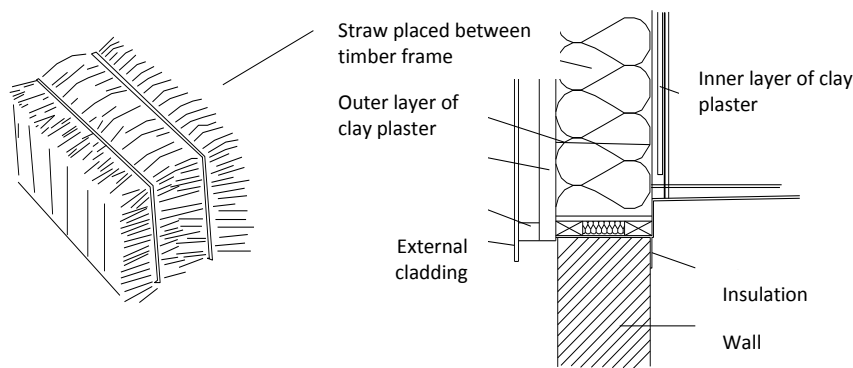

Fig.77. A scheme illustrating the basic module of insulating wall material (straw) and its position within the structure of a straw-bale wall [Author's scheme].

Wooden frame inside walls has been planned so as openings could be placed in between beams. In order to eliminate lintels (nadproża). Thanks to that, the whole construction is lighter and saves wood.

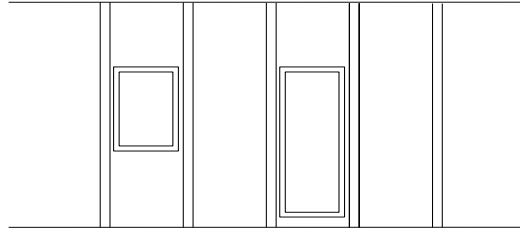

Fig. 78. A scheme illustrating rule for localization of the openings in the structure of straw-bale walls [Author's schemes].

Partition walls

Partition walls have been designed as straw boards 5 cm thick. They are nailed to wooden framing from both sides. Empty spaces between these boards are filled with a mixture of dried moss, wooden strips and tree-needles. It functions as both – insulation and acoustic barrier.

Partition walls may also be made out of straw mixed with clay. Their usual dimensions are: [length of the wall] x 25 x 12 cm. they do not require external framing, however they are reinforced with wooden sticks. The method for preparing the straw-clay mixture necessary for such partition walls is available in BN-62/6737-05 norm (O).

Slabs

The author has selected a beam-and-rib wooden slab filled with reed sticks (diameter 4-5 cm) wrapped with straw plaits covered with clay.

Alternative insulation for the selected slab may be using light-clay boards and placing them between slab boards. Upper side of the slab is usually finished with clay and the bottom part is often finished with boards. In the design – the author has decided to emphasize wooden construction of the slab (and avoid covering it with boards).

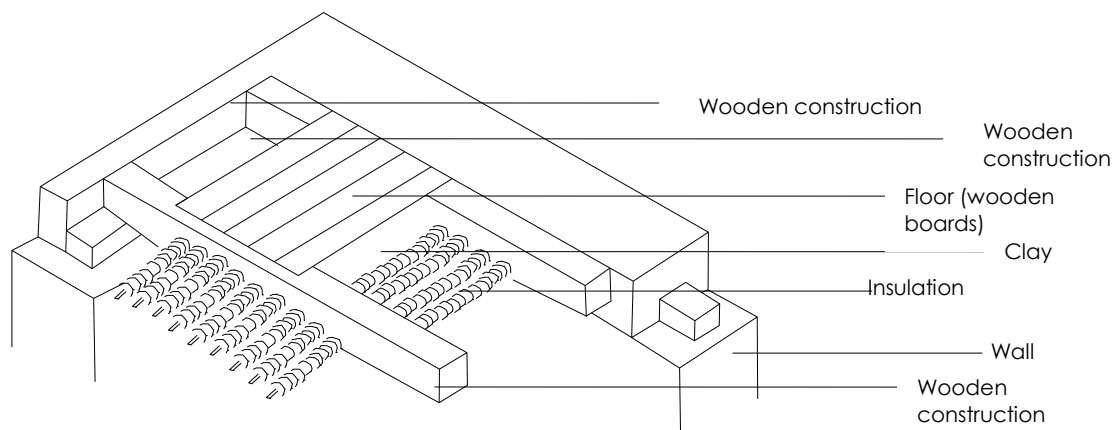

Fig. 79. Details of the slab filled with wooden sticks wrapped in straw plaits covered with clay

The weight of both slabs is supported by constructive beams (umgebinde) and root walls.

The slab above the first floor is thinner than the one above the groundfloor (there is no such need for acoustic and thermal insulation). It is thin also above the staircase. There is no esthetic need for exposing wooden elements in the entrance hall and staircase – using beam-and-rib slab would be a waste of wood. Therefore the author has designed much thinner slab.

The roof

Beams make the base of the roof structure. Wood used for this construction, preferably class K27, with maximal moisture level of 20% should be impregnated with natural materials.

Large part of the roof has been covered with fotovoltaic panels. Remaining part with wooden shingles adjusted in terms of structure to the facades.

Electrical installation

In the MPZP for the district of Bogatynia we may read that heating installation should be powered by either electricity or fuel (K). The designed house will be connected to the net however it will also be equipped with sun-powered electric system. Reason for connecting the house to the public net was obtaining a positive energetic balance (giving away the excess of energy produced in the summer and obtaining energy in winter or in case of insufficient production). In Weigsdorf (Wigancice Żytawskie) there is a power station (stacja transformatorowa) PT-735 14 (H). The designed house is planned to be powered by this station.

It is also worth to mention financial benefits of selling excess electricity to the net. According to Polish regulations³ the price of such green energy is higher than electricity produced in a traditional way. Therefore – users of the house, when they give away excess of electrical energy produced with the aid of solar systems, they earn much more, than later on they pay for energy when their solar systems are insufficient in covering the need for electricity in winter time.

The majority of Southern side of the roof is covered with fotovoltaic modules. They are placed also on the roof of the shed and garage shed. On the roof of the shed and house, the author has also designed some space for water-heating solar collectors.

An optimal angle for both of these solar systems is 45 degrees – thus in the designed house their productivity will be close to maximum.

Modules will be connected to inverter transforming DC (prąd stały) into AC (Prąd zmienny) used up by the equipment in the house (or given away to

³ Electrical law, a bill from 10 April 1997 „Rozporządzenie Ministra Gospodarki o obowiązku zakupu energii elektrycznej ze źródeł odnawialnych oraz wytwarzanej w skojarzeniu z wytwarzaniem ciepła” from 15 December 2000 (Dz.U.2003 Number 153, position 1504 with further changes)

the net). Electrical installation consists of: photovoltaic modules, batteries, photovoltaic inverter, energy meter end energy receivers.

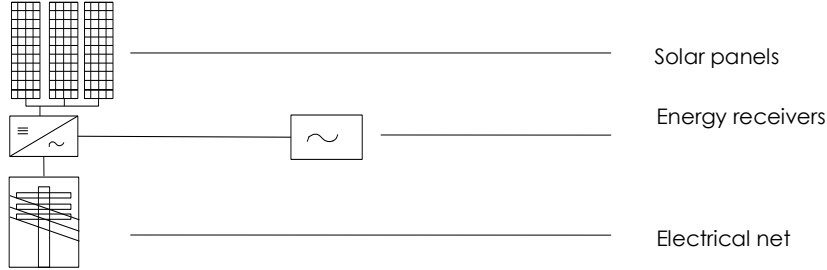

Fig.80. A scheme of the electrical system [Author's scheme]



Fig.81. Examples of solar tiles that may be used as photovoltaic panels in the designed house (R)



Fig.82. Polymer solar tiles (S)

In order to meet one of the LEED certification terms (discussed in the further part of the work) the author has selected German Solar panels. They are produced in certified quality – but will not need energy-absorbing and costly transport – it reduces the carbon footprint of the roof cover.



Fig.83. Solar tiles used in the designed house (T)

This solar alternative for a regular roof tile is accessible as a calculation of kW of energy it produces. Therefore the owners may easily decide, what percentage of the roof area they want to cover with it. It is light thus optimal for the construction of the roof. Its color (graphite) may easily be adjusted to facades (T).

Heating and Ventilation

The author has decided for a heating installation equipped with energy meters, mechanism of detailed regulation and system of weather sensors. Additionally – in order to pre-heat or pre-cool the air taken from the outer absorber, a ground heat exchanger has been designed. It is a simple vitrified clay pipe (krzemionkowa rura) of 30-50 metres that is placed around 1 meter underground. The pipe ends in inlet that is covered with a net protecting it from insects and small animals. After investigating the shape and size of the site, it turned out that optimum for the ground heat exchanger for this design is 52 metres with inlet localized between trees in the backgarden. One end of the heat exchanger will be localized at the depth of 2 metres (in the garden) and the other - at the depth of 1,5 metres in the foundation wall of the house. Fresh air will be coming in with the use of free standing air intake. The beginning of the exchanger pipe (from the inlet side) needs to be lower than the point in which it is connected to the house in order to allow water steam to condensate (especially in summer time) to drain down.

It will then get to a joint finished with a sieve-like plug. Underneath such a plug – there is a gravel layer that exceeds soaking of water into the ground. Efficient mechanism of disposing excess moisture is crucial for the fresh air quality. In the point, where the pipe goes through the foundation wall – it needs to be made out of very elastic material – only then the noises of the air are reduced and the whole system is not being damaged by effects of thermal expansion. Heat losses are additionally reduced by other heat exchangers they take the heat from ventilated air and sewage system (fermentation).

According to Polish regulations⁴ a fireplace may not be the only source of heat for the house. It is the main reason, why the author has provided the house with additional surface heating. The heat will be taken from collectors absorbing solar energy and changing it directly into heat. Such collectors in case of the designed house will be localized under the optimal angle – thus this system will be able to cover 100% need for hot water. The container for hot water will also be equipped in electrical heater (that will mainly serve disinfection and as an additional source of heat – in case the system broke or turned out insufficient in extraordinary conditions). Hot water will be distributed via system of floor and wall pipes - in such a way the whole house will gain an effective heating system. System of heating pipes will be placed within the inner clay-plaster (the last layer of straw-bale walls). It is worth to remember that, in fact, it is the whole wall that serves as a heater, not only

⁴ art. 132 of Polish building law

these inner pipes. Consequently – it is worth to plan the furniture placed on such walls beforehand – the more wall we cover, the less heat we get. Similarly – the more clay plaster, the more heat we get, but also the more inert the system gets. It needs more time to cool down and get warmed up again.

When installing pipes on walls or floors – we first put the insulating layer, then the first layer of clay, only then heating pipes and remaining layers of clay.



Fig. 84. A photography illustrating the process of heating pipes installation (N).

It is worth to mention, that such system is very economical since it reduces any heat loss. Straw-bale walls are insulated with very thick layer of straw, thus all the heat stays in the house. Such heating pipes should also be installed in seemingly unnecessary spots – in order to eliminate cold areas.

When we mention surface heating (floor, walls, even ceilings) it is worth to point out the ways in which it differs from standard heating solutions. Traditional radiators heat the air. It evokes circulation - hot air goes up, cold air goes down and so on. In the case of surface heating the mechanism is rather focused on comfort of heat perception. It is similar to natural mechanisms – the sun heats up the ground that then radiates the heat to us. In the case of floor heating – the floor, in a way, mimics this mechanism. Such pipes placed either in floor walls or ceilings might also be used in summer – for cooling.

Radiation of heat from floors, walls or ceiling may additionally be increased when parallel surfaces are dark – then heat waves will not be reflected. If, for instance, the floor is covered with material especially adjusted to heating ceilings – it becomes a heater too.

In general – the temperature of a heating surface is not higher than 35 degrees (which reduces burning of dust in higher temperatures – usual source of allergens). The energy given away by heating surfaces amounts to some 60-70%. In the designed house, the author has decided to use a lot of ceiling heating due to selection of wood as a material for flooring (wood does not transmit heat as good as clay, ceramics or stone does – it is rather an insulating material).

Floor heating has been designed in those interiors, that use stone ceramics for flooring (kitchen, corridors, bathrooms, art studio, laundry room etc.)

Important parts of heating system are two root walls – also functioning as surface heating. Their heating surface has been additionally increased by sculpted ceramic patterns – they maximize the contact surface thus provide

more heat exchange between the air and warm walls. Details of these sculptures will be discussed in the further part of this work.

Heating system of the designed house is characterized by a lot of inertia, therefore a lot of attention has been given to solar blinds in windows (especially on the ground floor) that allow reducing the direct sunlight heat. A lot of clay or clay-based materials (plasters, flooring, ceiling plasters) also help to maintain positive microclimate in the interior (clay absorbs excess moisture from the air and gives it away when the air is too dry). Even though clay in the designed interiors provides them with great microclimate, a lot of attention has been given to ventilation.

Mechanical ventilation in the building has focused on analyzing two variants – when the system works properly and when, due to various reasons, it is shut off. Thus energetic safety of the house is guaranteed by the fireplace. When heating and ventilation is turned off – the fireplace (centrally localized in the house) provides heat and the chimney provides ventilation (gravity ventilation).

In regular conditions – the shaft of the chimney is closed - it might be opened manually when the mechanical ventilation is turned off or when the family wishes to use the fireplace.

The scheme below illustrates the rule for prioritizing interiors in terms of fresh air by localizing air exhaust openings in bathrooms and other rooms with higher air moisture.

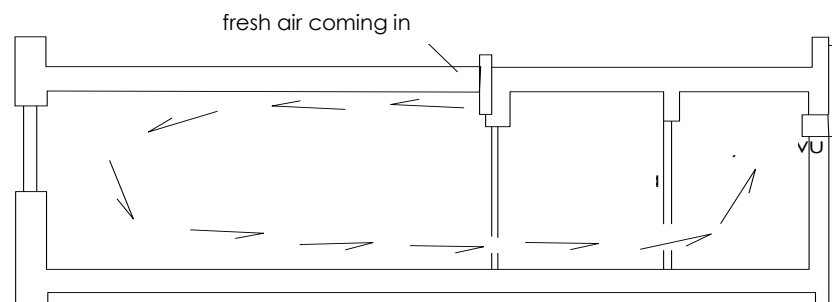

Fig.85. Simplified scheme of ventilation system [Author's scheme]

Water and sewage system

As we read in *Studium* for district of Bogatynia in chapter *Water*, natural water system in the region is determined by the influence of the coalmine. The spoil-tip of overburden ground has destroyed water systems in the area between Sieniawka – Opolno Zdrój – Weigsdorf (Wigancice) – Turoszów. Now, in their place, there are only excavations and mine shafts. Therefore, when selecting water-sewage system for the designed house, the author has decided to propose collecting rainwater and using it in the house (after cleaning in especially provided installation) and creating a private sewage system localized under the lawn of the designed house. It uses natural methods for utilization of liquid sewage produced in the household.

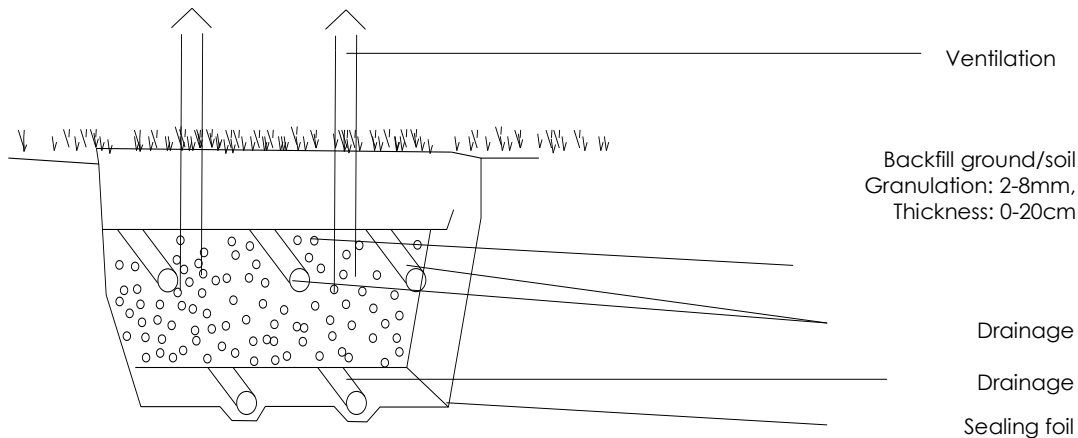

Fig.86. A cross-section of a sewage system used on the designed site [Author's scheme]

When placing a sewage container in the ground, it should be at least partially filled with water in order to prevent its damages. The size of the container oscillates around the average 3m² per person (M). Instead of 1 mm foil one may use bentomat that is usually a bit more resilient to damages. Draining pipes on the bottom of the filter should be covered with lagging (otulina) (M).

In wintertime, such a sewage system is 10%-20% less effective, because dormant vegetation does not take active part in the purification process. Therefore – 80% of productivity is achieved by gravel (or sand) and its biofilm (błona biologiczna). That is why it is so important to wash the gravel thoroughly before using it in the sewage treatment. Water from the shower is not polluted with biological waste (such as kitchen-sink water) therefore it might be re-used for flushing toilets before it finally gets to the sewage treatment, therefore in the further part of the work, the author has focused on various natural detergents and cleaning substances that may aid in prolonging the time of use for such sewage treatment points.

Drinking water for the house is produced from rainwater in the process of purification. Rainwater is being collected in a container localized in the shed, where it is pre-heated by the warmth of the neighboring fermentation container (kompostownik) (in wintertime the heat from this container is also used for the heating installation placed in communication paths around the house). The water is pumped from the rainwater container, (in amount necessary at a given moment) into the system of further purification.

One of natural water filters has been provided for further cleaning of drinking water. There are various types of filters that may be used for an installation like the one in the designed house: active carbon filter (it absorbs mainly organic pollutants and chloride) despite being a cheap option, needs however to be frequently refilled, reverse osmosis filters (water goes through a membrane that stops pollution) successfully remove nearly all pollutants from water, however they also deprive it of mineral salts and they are produced from expensive plastic. Third means for water purification is distillation. Water that is prepared in such a method is very clean however quite expensive. The

end product of the boiling and condensation process is water deprived of gasses dissolved in it (such as heavy metals, chlorides, radon, but also mineral salts). While boiling – all the bacteria and viruses are destroyed. For such distiller – an active carbon filter should also be added in order to stop organic pollution. Such distillers should be made of glass.

Thanks to the excess heat produced in the shed during the time, when sauna is used by dwellers of the house – the heat-consuming distillation has become a wise solution. A portion of distilled water (produced when sauna is used) is stored in a special container and when clean water is needed in the house it is transported there via system of pipes that are equipped with an active carbon filter that removes any biological pollutants.

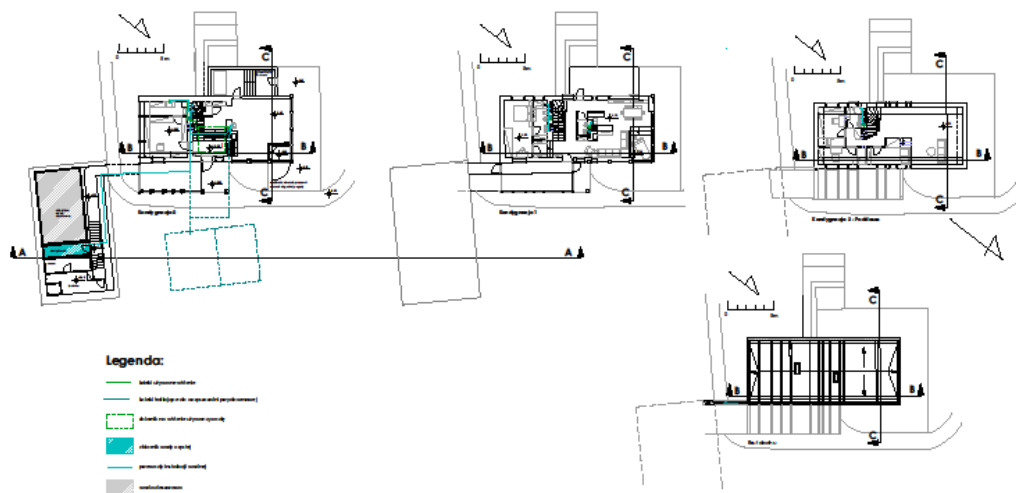

Fig.87. A scheme of water-sewer installation for the designed site [Author's scheme].

Finishing

In the design, the author has decided to use clay plasters that provide interiors with a positive microclimate. Clay is antistatic and regulates the degree of air moisture. It is also the only such elastic material that enables sculpting it into various unique details. The latter quality has been used in the designed house – especially on the root walls.

Light clay walls may be covered with clay plaster, when they are completely dry (moisture below 5%). The interior of the house is covered with 3-4 layers of plaster in periods of time separating following layers. Each of them should be dry before the next one is put. The last one should be mixed with casein, whey or linen oil in order to give it a fine finishing.

Clay walls are very hard, especially when completely dry – therefore any wires or other installations should be placed in it, when it is still wet. Later cuts are very time and energy consuming.

For achieving colors – one may use lime or clay paints, but also natural pigments added directly into clay plasters.

3.3.3 Details

Knowing that the greatest enemy of a clay building is an excess moisture, horizontal insulation should be provided in such spots as basement wall, underneath flooring, under windowsills and on every finishing of constructive walls (in case of moisture from leaking roof).

Window detail

From energetical point of view it is optimal to design relatively big windows that have as small framing as possible. Thanks to that – we gain more sunlight heat. Window frame is the point, where the direct connection with glass creates thermal bridge.

In the designed house, windows are equipped in a mechanism of wooden blinds activated automatically by weather sensors but also manually by users of the house. These wooden blinds are placed in the space between two plates of glass. Such space additionally increases insulating qualities of such windows.

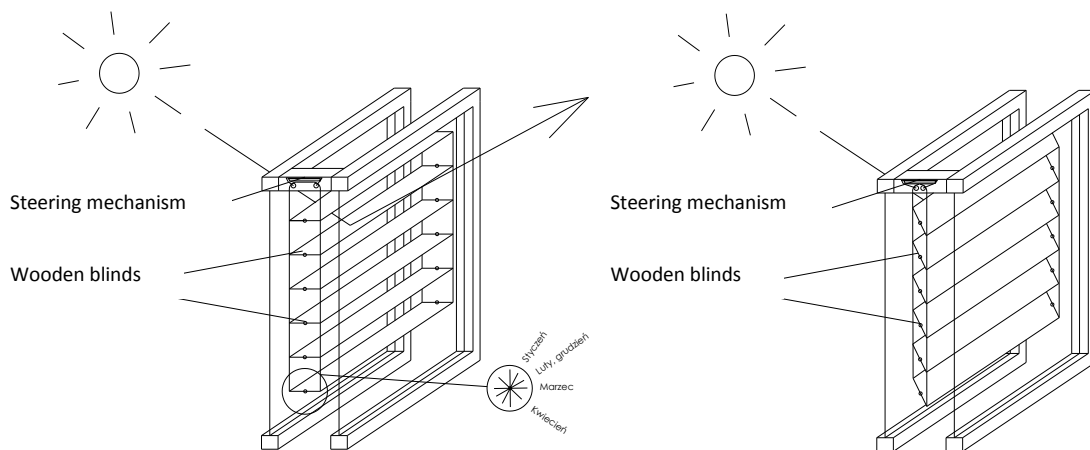

Fig. 88. A scheme illustrating mechanism of wooden window blinds [Author's scheme]

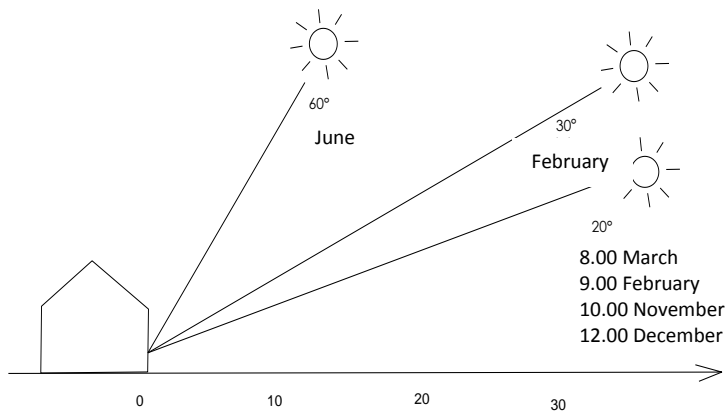

Fig. 89. A scheme illustrating approximate angle of sunlight penetration for the designed house [Author's scheme].

3.4. Interior design

In this part of the work, the author has discussed only non-standard solutions that have been provided for the designed house. Discussing traditional interior-design details was not the point of this work.

The house

In the art studio, the author has provided a big heating wall that will allow for delicate drying of paintings and sculptures.

In order to obtain the possibility of observing sculptures from various perspectives, the art studio has been lowered in order to make the use of natural differences in the terrain levels. Connecting studio with exterior via one of the windows gives possibility to work both in and outside the house.

The author has also provided a special clay container (located in the floor level, with no direct sunlight – optimal conditions for sculpting clay). It allows direct access to work material – it saves a lot of time and effort for the artist and additionally provides him with sculpting clay of best quality (because kept on optimal conditions).

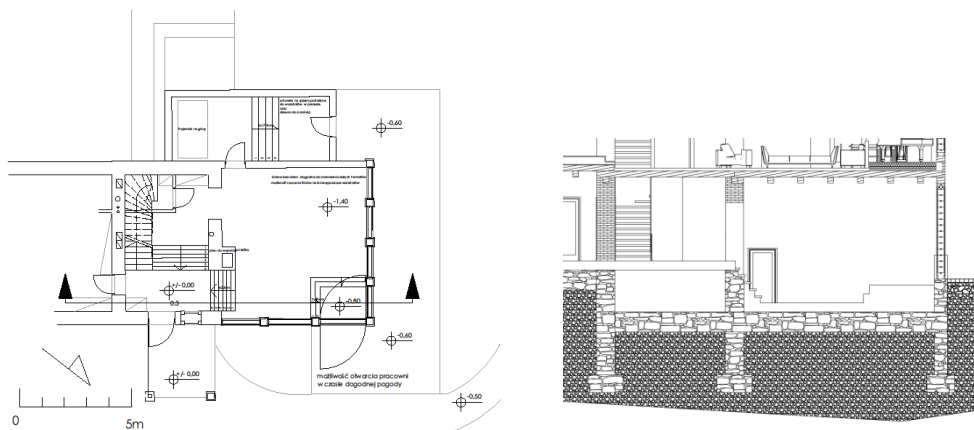

Fig.90. Art studio floor plan – cross section [Author's scheme]

The difference in height of interiors, just like at the groundfloor, has been used also on the upper floor. It has been used to differentiate the day-zone (living-room, kitchen, dining room, hobby) from the night-zone (bedroom, bathroom etc.). Underneath the piano - the difference in height is used for acoustic insulation. Within the two-step higher floor, the author has placed a double slab that does not allow so much noise into the artstudio below. Day-zone is thus two steps higher than the night zone. It allowed better exposure of the wooden beam-and-rib slab.

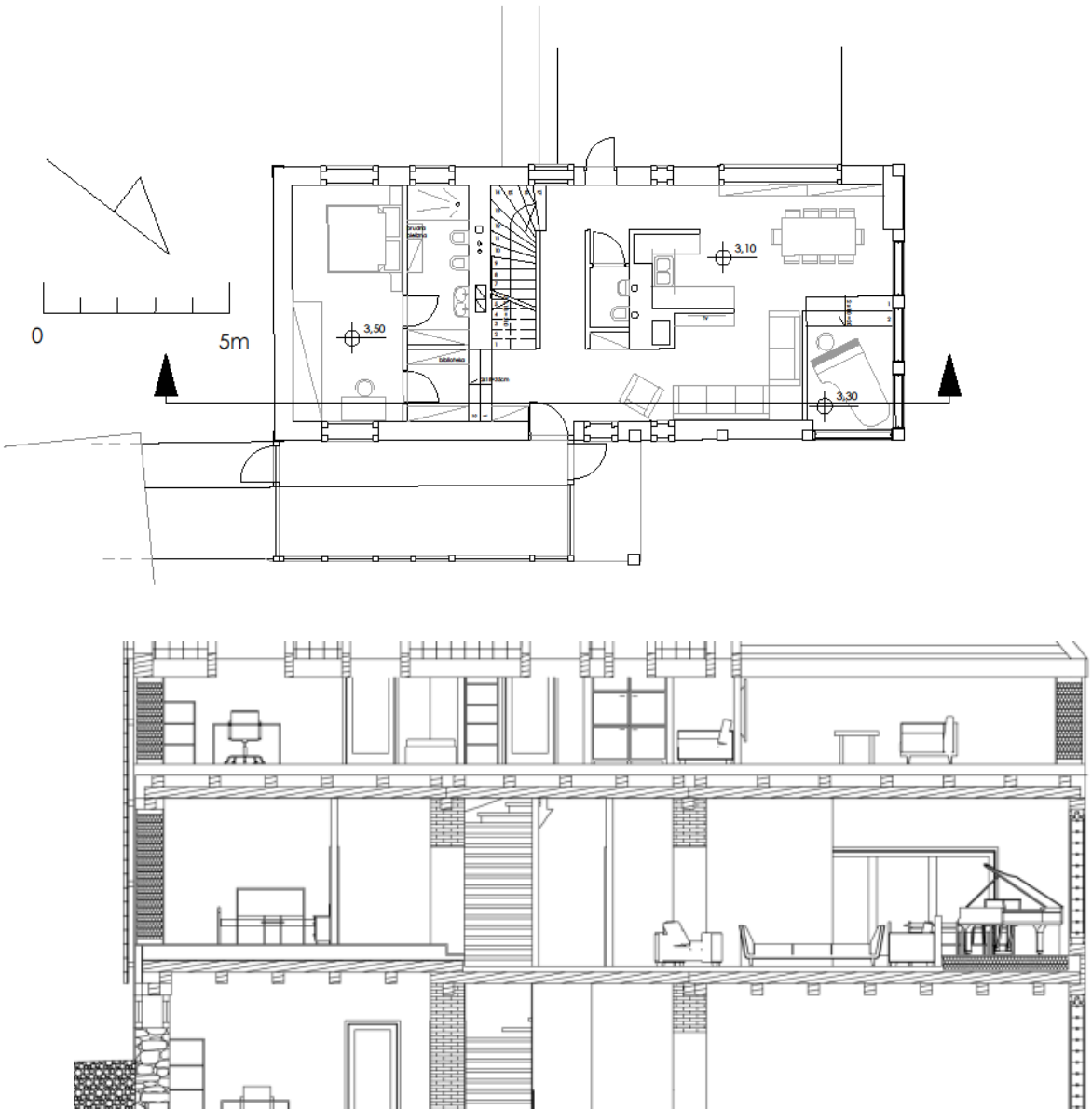

Fig.91. Upper floor plan and section [Author's scheme].

The shed

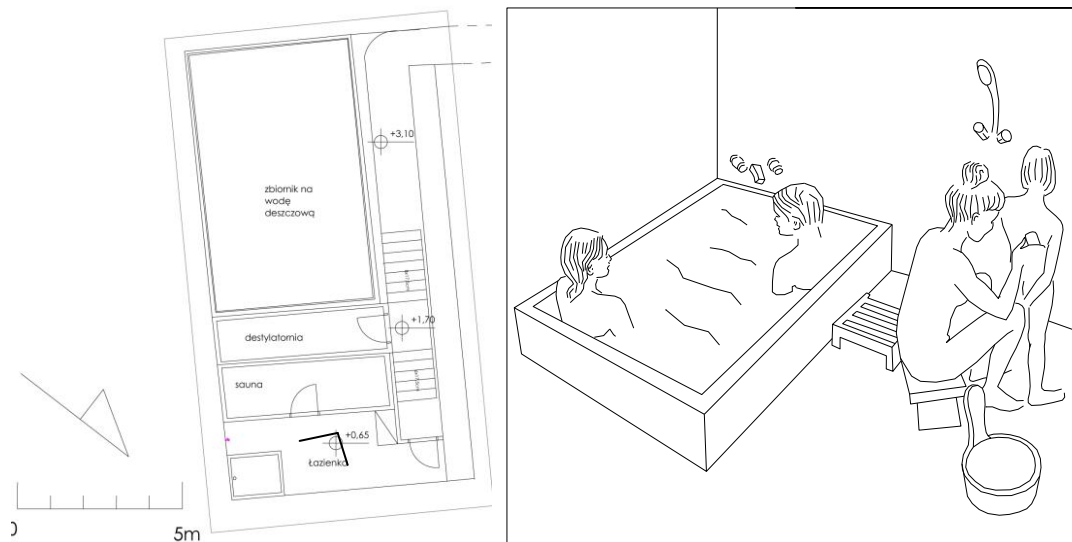

Fig.92. Floor plan of the slab and interior of the spa zone [Author's schemes]

The shed, the building next to the house, has been used as a private SPA – entirely powered by sun energy supported by the heat produced in the process of fermentation (container for biodegradable waste). The author has planned sauna connected with a house bathroom. High temperatures (side effect of using sauna) are used for distilling rainwater used both in sauna and in the house. In the design of the bathroom interior – a central place belongs to a Japanese – style bath. Its narrow, but deep shape minimalizes evaporating surface.

3.5. Design of details for the interior

Majority of details especially designed for the interiors of the house are based on the motive of local fauna curiosity. Sweet water mussel *Margaritifera Margaritifera* has been popular for its pearls and characteristic mussel shape. It is now an extinct species, however there are still some attempts to restore its population (U).



Fig.93. Photographs of an inspiration for interior design details – sweet water pearl mussel – *Margaritifera Margaritifera* (U).

Lamp



Fig. 94. Photographs of a model of a lamp – author's sculpture [Author's photographs].

Decorative tiles



Fig. 95. Photograph of author's sculptures – clay (ceramic) tiles for the root walls and fireplace [Author's photographs].

Ceramic tiles have been designed in two coloristic versions depending on the type of clay used for their production (brown or grog clay) and size (10x10 or 20x20 cm). Modular sizes allow for chess-like compositions.

General maintenance guidelines

In the design of the house, as well as in the interior design, the author has decided to use only natural, ecological and healthy materials. Function of the designed installations in the house would be changed if dwellers of the house did not take in a healthy lifestyle that eliminates substances that could be unhealthy or harmful – beginning with building materials and finishing with everyday life accessories.

In the designed house, traditional kitchen gas installation has been replaced with electrical one (powered by solar energy). As a consequence of that - there is no need for liquid gas containers (or access to gas installation) no fumes and better ventilation and air quality in the house. Building materials that could be harmful for health have been replaced by much healthier counterparts. Basic cleaning substances and wood polish has been replaced by natural bee waxes. Paints and varnishes have been replaced by clay with linen oil or casein. Detergents have been removed from everyday use - soap nuts are used even for laundry.

Lemon, eucalyptus and lavender oils have disinfecting qualities that may also be used for cleaning. Critical detergents used for toilets may be replaced by vinegar left for the night and scrubbed with the use of baking soda. Floor and furniture polishers may be replaced by bee wax and other natural oils. Herbal soaps, shampoos are accessible on the market and they will also aid in prolonging the time of using the sewage system of the house.

3.6 Summary of the design (based on LEED Certification System)

Since, when designing the house, the author has been aiming at ecological and sustainable solutions, as a summary, the house has been discussed in terms of LEED (Leadership in Energy and Environmental Design) certification system. It has been created in 1994 by Green Building Certificate Institute (CBCI) (27). It is divided into various categories: LEED for new construction and LEED for existing buildings, LEED for Commercial Interiors, Care and shell, Homes, Neighbourhood Development, Schools, Retail (27). In this case LEED for Homes has been selected.

Maximal number of points that a certified object may get, accounts to 100. Additionally one may get 10 bonus points for *Innovation and Design* and *Regional Priority*. These extra points are not taken into consideration in general certification, however they have been very important for the designed house presented in this work.

In the sub-chapter below, the author has presented basic criteria for LEED certification system with a commentary about the designed house.

1. Sustainable site.

The design of the site prevented negative consequences of raising a building on the site, such as erosion of the ground, excess of building waste, ashes and other pollution emission (also by reducing unnecessary transportation of building materials). All the existing trees on the site have been preserved and the design provided only minimal area of hard

groundcover (powierzchnia utwardzona) while maximizing the biologically active surface. Thanks to covering parking place with greenery and photovoltaic panels, the possibility of local overheating of the ground has been excluded.

The design has been localized on the site with an easy access to both – road and rail infrastructure and in the vicinity of foot and cycle tracks. In the closest vicinity there is also attractive social infrastructure. In Bogatynia, 14 km away from Weigsdorf (Wigancice Żytawskie), there are: a hospital, nurseries, kindergarten, schools, higher education facilities, libraries, sports facilities and local cultural centers.

In the design, the author has eliminated the negative influence of lightning upon the direct vicinity of the designed site. The author has selected modern luminaires activated by movement sensors. Thanks to that – artificial lighting is minimalized.

2. Water efficiency

The house has been designed as independent of external water and sewage system. For the purposes of dwellers - rainwater is purified and used. Part of water is re-used (shower water is used for flushing toilets). There is a clear distinction between drinking water and water used for other purposes (working, watering plants). Additionally, fittings with aerator that decreases water use has been used.

3. Energy and Atmosphere

Optimization of energy system has been obtained by using solar energy and power-saving equipment (such as LED light). Renewable energy sources vastly exceed minimal for LEED 35%. Only small part of overall electricity is taken from the net (especially during dark days of wintertime) lowering consumption of electrical energy is also achieved by underground heat exchanger and other recuperators of heat. They minimize consumption of energy necessary for heating.

4. Materials and resources

The new house has been designed in such a way so as to fit the original floor plan of the original building localized on the site in the past, therefore existing foundations will be reused in the newly built house. A lot of building materials of the newly designed house are in fact building waste (fieldstones, straw from local fields, clay taken from the ground dug out during placing the heat exchanger pipe) or local materials (straw, stones from local fields and wood from local sawmill) and renewable (clay, straw, wood). There are containers for recycling biological waste, containers for glass, plastic and paper waste that may be further recycled. They are localized in the vicinity of the road, therefore it is easy to transport it to the nearest recycling points. Even sculpting clay is reused after work – leftovers get back to the container where they again acquire moisture that makes it plastic and ready to use for sculpting.

5. Indoor environment quality

A problem of nicotine smoke is practically absent, since smokers may use the winter garden accessible from the living room where plants may neutralize smoke. Ventilation system has been equipped with CO₂ sensors that

automatically control amount of fresh air from the outside. Dwellers of the house may also open windows themselves. Similarly, heating and lighting is automatized thanks to heat and movement sensors. Users may also control it manually. Access of natural sunlight is minimized thanks to vast openings.

6. Innovation and Design

The form of the building is adjusted to natural terrain - it fits into surroundings and completely adjusts to its form – does not become dominant in space. Historical elements of the construction form a dialogue with traditional architecture of this region.

7. Regional Priority

The design has taken meaningful environmental factors characteristic to this geographical region. The form and construction of the building does prioritize local umgebinde tradition and continues it in contemporary form.

Conclusion

The design project discussed in this chapter aimed at illustrating that local umgebinde construction as an irreplaceable source of inspiration for new forms, some building patterns are unchanged for many years, therefore their continuation in contemporary form is a natural evolution of local traditional architectural style.

In the contemporary era of eco-design – there is a perfect moment to promote sustainable solutions that lower exploitation cost of a house. In order to meet 21st century needs we do not need to blindly copy foreign technologies, but we may use our own traditional techniques enriched in their modern reinterpretations.

On the basis of this modern reinterpretation of an umgebinde house, the author has epitomized that it is possible to design a contemporary house that fits into local building tradition and follows latest architectural trends at the same time. As it is demonstrated – one may derive inspiration from barely any local element (fauna, flora, not only architecture) in order to achieve unique results that will grow out of local traditions and will allow future users of such buildings identify strongly with the region

List of Figures:

- Fig. 1. A map illustrating the localization of Lusatia in Europe (Author's scheme)
- Fig. 2. A map illustrating the localization of the railway in the neighborhood of the analyzed area.
- Fig. 3. A scheme illustrating a structure of a typical umgebinde house
- Fig. 4. A scheme illustrating the structure of an umgebinde house from Weigsdorf (Wigancice Żytawskie) [Author's schemes].
- Fig. 5. A scheme illustrating the development of the umgebinde structure. 1. Umgebinde supporting the roof – 2. Half-storey long-beamed structure – 2. Half-story short-beamed structure.
- Fig. 6. Schemes illustrating some examples of umgebinde houses with various spans of constructive beams.
- Fig. 7. Site-Plan of the Gruszków village (Grey color is used to mark the inn) (26)
- Fig. 8. Site Plan of Bukowiec village (grey color is used to mark the inn) [26]
- Fig. 9. Site Plan of the Miskowice village (grey color is used to mark the inn) [26]
- Fig. 10. Site Plan of (Wyszków), (Wolanów) and Weigsdorf (Wigancice Żytawskie) (Map from 1938) [Author's scheme].
- Fig. 11. (Turoszów) on an old postcard (A)
- Fig. 12. (Turoszów) after it has been overtaken by the coalmine (A)
- Fig. 13. A scheme illustrating the localization of the analyzed villages [Author's schemes] and a satellite picture illustrating the influence of the KWK Turów in the region (F)
- Fig. 14. Dornhennersdorf (Strzegomice) on the old postcard (A).
- Fig. 15. (Zatonie) on the old postcard (A)
- Fig. 16. Photographs of some buildings that are what is left of the (Zatonie) village in the present day [Author's photos].
- Fig. 17. Weigsdorf (Wigancice Żytawskie) on an old Postcard (C)
- Fig. 18. Weigsdorf (Wigancice Żytawskie) on an old Postcard. From the left : local post, postal carriage, industrial buildings.
- Fig. 19. A school from Weigsdorf (Wigancice Żytawskie). From left: on a historical postcard (C) and on a photo [Author's photos]
- Fig. 20. A church from Weigsdorf (Wigancice Żytawskie) that has been preserved till the present day on the Czech territory. From left: old postcard (C) and a contemporary photograph [Author's photo].
- Fig. 21. Remnants of former buildings in Weigsdorf (Wigancice Żytawskie) [Author's photos].
- Fig. 22. Localisation of the area analysed as a context for the design of the house [Author's schemes]
- Fig. 23. Urban outset of the analyzed region – present times [Author's schemes].
- Fig. 24. A scheme illustrating typical localisation of the buildings on the site [Author's schemes]
- Fig. 25. A scheme illustrating linear setups of houses [Author's scheme]
- Fig. 26. A scheme illustrating courtyards created via characteristic setups on given sites [Author's schemes]
- Fig. 27. Examples of details from Maxdorf, Friedreich and Visnova [Author's schemes]
- Fig. 28. Analysed area marked on a scheme based on the map from 1938 [Author's scheme]
- Fig. 29. A scheme illustrating the development of an umgebinde construction [Author's schemes].
- Fig. 30. Photographs of umgebinde houses in Poland and Czech Republic [Author's photos]
- Fig. 31. Photographs of bigger umgebinde houses in Bogatynia and Miskowice [Author's photos]
- Fig. 32. Maxdorf – characteristics of the local architecture [Author's collage].
- Fig. 33. Friedreich - characteristics of the local architecture [Author's collage].
- Fig. 34. Weigsdorf – remnants of a house [Author's photos]
- Fig. 35. Chata Kotodzieja – fasades: Eastern, Northern, Western and Southern [Author's schemes].
- Fig. 36. Chata Kotodzieja before (Photograph from private collection of the owner of the house) and after translocation [Author's photos]
- Fig. 37. A table illustrating the proportion of the roofcover floor in relation to the overall surface of the building (16) [Author's scheme]
- Fig. 38. Traditional wooden roofs [Author's schemes]
- Fig. 39. Photographs illustrating the variety of roof forms in Upper Lusatia [Author's photographs]
- Fig. 40. A scheme illustrating one of the traditional roof window type [Author's scheme]
- Fig. 41. Examples of various traditional types of roof cover for umgebinde houses. From the left: slates and ceramic tiles [Author's photographs].
- Fig. 42. A scheme illustrating localisation of door in umgebinde houses [Author's scheme]
- Fig. 43. Examples of entrances to typical umgebinde houses [Author's photographs]
- Fig. 44. Examples of windows in typical umgebinde houses [Author's schemes]
- Fig. 45. Various types of decoration of gable walls in umgebinde houses [Author's photos]
- Fig. 46. Examples of detailing [Author's photos]
- Fig. 47. A map illustrating the net of roads in the Polish part of Polish-Czech borderland (J)
- Fig. 48. A map illustrating the net of rail tracks in the Polish side of Polish-Czech borderline (J)
- Fig. 49. A map illustrating industrial regions of the Polish-Czech borderland (J).
- Fig. 50. A map illustrating tourist attractions of the Polish – Czech borderland (J)
- Fig. 51. A map illustrating the areas of best environmental qualities in the Polish-Czech borderland. (J)
- Fig. 52. A map illustrating water supply in the Polish part of Polish-Czech borderland (J).
- Fig. 53. A scheme illustrating the wind-protecting function of trees located in the Northern part of the site [Author's schemes].
- Fig. 54. A scheme illustrating the characteristics of the dwellers of the designed house (Author's schemes)
- Fig. 55. A scheme illustrating functions of particular rooms – its' changes in time [author's schemes].
- Fig. 56. A scheme of the new design of the site plan [Author's schemes]
- Fig. 57. Section of the site [Author's scheme]

Fig. 58. Level 0 floor plan [Author's scheme]
 Fig. 59. Level 1 floor plan [Author's scheme]
 Fig. 60. Level 2 floor plan [Author's schemes]
 Fig. 61. The plan of the roof [Author's schemes]
 Fig. 62. Section B-B. [Author's schemes]
 Fig. 63. Section C-C [Author's scheme]
 Fig.64. Floor plan and cross-section of the sched [Author's schemes].
 Fig.65. Northern facade [Author's scheme]
 Fig.66. Southern facade [Author's scheme]
 Fig.67. Eastern facade [Author's scheme]
 Fig.68. Western facade [Author's scheme]
 Fig. 69. Simplified scheme of the inspiration for functional solutions [Author's schemes]
 Fig. 70. Functions in the interior of the house [Author's scheme]
 Fig. 71. Comparison of the traditional building materials and solutions in the designed house [Author's scheme]
 Fig. 72. A scheme illustrating basic construction elements of the designed house [Author's scheme]
 Fig. 73. Examples of contemporary clay floors impregnated with natural waxes and linseed oil.
 Fig. 74. A scheme of a clay floor [Author's scheme]
 Fig. 75. A scheme of the wooden blinds' mechanism [Author's schemes]
 Fig. 76. Visualization of the glazed part of ground floor walls [Author's work]
 Fig. 77. A scheme illustrating the basic module of insulating wall material (straw) and its position within the structure of a straw-bale wall [Author's scheme].
 Fig. 78. A scheme illustrating rule for localization of the openings in the structure of straw-bale walls [Author's schemes].
 Fig. 79. Details of the slab filled with wooden sticks wrapped in straw plaits covered with clay
 Fig. 80. A scheme of the electrical system [Author's scheme]
 Fig. 81. Examples of solar tiles that may be used as photovoltaic panels in the designed house (R)
 Fig.82. Polymer solar tiles (S)
 Fig. 3. Solar tiles used in the designed house (T)
 Fig. 84. A photography illustrating the process of heating pipes installation (N).
 Fig. 85. Simplified scheme of ventilation system [Author's scheme]
 Fig. 86. A cross-section of a sewage system used on the designed site [Author's scheme]
 Fig. 87. A scheme of water-sewer installation for the designed site [Author's scheme].
 Fig. 88. A scheme illustrating mechanism of wooden window blinds [Author's scheme]
 Fig. 89. A scheme illustrating approximate angle of sunlight penetration for the designed house [Author's scheme].
 Fig. 90. Art studio floor plan – cross section [Author's scheme]
 Fig. 91. Upper floor plan and section [Author's scheme].
 Fig. 92. Floor plan of the slab and interior of the spa zone [Author's schemes]
 Fig. 93. Photographs of an inspiration for interior design details – sweet water pearl mussel - *Margaritifera* (U).
 Fig. 94. Photographs of a model of a lamp – author's sculpture [Author's photographs].
 Decorative tiles
 Fig. 95. Photograph of author's sculptures – clay(ceramic) tiles for the root walls and fireplace [Author's photographs].

References:

1. Bena Waldemar, *Polskie Górne Łużyce. Przyroda - Historia – Zabytki*, Wydawnictwo F. H. Agat, Zgorzelec 2003.
 2. Bernett K., *Umgebindehauser*, Berlin, 1988
 3. Borcz Zuzanna *Infrastruktura terenów wiejskich*, Wydawnictwo Akademii Rolniczej we Wrocławiu, Wrocław 2000.
 4. Czekanowski J., *Wstęp do Historii Słowian*, Poznań 1957.
 5. Delitz F., *Umgebinde im Ueberblick*, Zittau 1987
 6. Dudzińska-Jarmolińska Agnieszka *Zielone Budynki – Symbioza Martwej Materii z Żywą*, w *Habitaty Pro-Eko-Logiczne – Prace Naukowe Wydziału Architektury Politechniki Wrocławskiej*, Oficyna Wydawnicza Politechniki Wrocławskiej, Wrocław 2010.
 7. Gaczkowska A., *Revitalisation Of The Umgebinde Houses By Private Investors In The Zgorzelecki District In Lower Silesia, Poland*, W: *Carriers of Space Patterns and Construction Types: German Migration and Architecture in Chile 1852-1875*, Berlin 2010.
 8. Gaczkowska Agnieszka *Tożsamość nie Tożsama. Zmiana Stosunku do Architektury Przystupowej w Polsce*. Publikacja pokonferencyjna: III Konferencji Naukowej PP „Tożsamość Miasta w Dobie Globalizacji”, 15-16 Października 2010. Publikacja w „Zeszytach Naukowych Politechniki Poznańskiej (w opracowaniu).
 9. Górniewicz Barbara, *Geneza, Rozwój i prognozowanie wiejskich układów osadniczych*, Politechnika Krakowska im. Tadeusza Kościuszki, Kraków 1999.
 10. Kozak Barbara, *Kształtowanie Architektury Proekologicznej – Rozwiązania Proekologiczne a Forma budynku*. W „Habitaty Pro-Eko-Logiczne” – Prace Naukowe Wydziału Architektury Politechniki Wrocławskiej, Oficyna Wydawnicza Politechniki Wrocławskiej, Wrocław 2010.)
 11. David Pearson „Jak Stworzyć zdrowe, harmonijne i ekologiczne mieszkanie. Przyjazny Dom”, Wydawnictwo Murator, 1998, ISBN 83-904692-5-1
 12. Jan Mikoś : „Budownictwo ekologiczne” Wydawnictwo Politechniki Śląskiej Gliwice 2000.
 13. Pokropek Marian, *Budownictwo Ludowe w Polsce*, Ludowa Spółdzielnia Wydawnicza, Warszawa, 1976.
 14. Rewers Ewa, *Post-Polis. Wstęp do Filozofii Ponowoczesnego Miasta*, UNIVERSITAS, Kraków 2005.
 15. Ruszczyk Grażyna, *Drewno i Architektura. Dzieje budownictwa drewnianego w Polsce*, wydawnictwo Arkady
 16. Szyller Stefan, w *Ignacy Tłoczek Polskie Budownictwo Drewniane*, Wrocław 1980.
 17. Tłoczek Ignacy, *Polskie Budownictwo Drewniane* Wrocław 1980
 18. Tłoczek Ignacy, *Dom mieszkalny na Polskiej wsi*, Państwowe Wydawnictwo Naukowe, Warszawa 1985.
 19. Tobolczyk Marta, *Narodziny Architektury*, Wydawnictwo Naukowe PWN, Warszawa 2000.
 20. Trocka-Leszczczyńska Elżbieta, Rdzawska Elżbieta *Budownictwo Przystupowe Jako Wspólne Dziedzictwo Trzech Narodów – Walory Artystyczne Detalu Architekturalnego*, w IV Polsko-Niemiecka Konferencja „Architektura Ryglowa-wspólne dziedzictwo” Szczecin, 2003
 21. Trocka-Leszczczyńska E. *Wiejska Zabudowa Mieszkaniowa W Regionie Sudeckim*, Wrocław 1995.
 22. Wojtkun Grzegorz w, *Osiedle Mieszkaniowe w Strukturze Miasta XX Wieku*, Szczecin 2004.
 23. Zaniewska Hanka (red.) *Ignacy Felicjan Tłoczek. Urbanista- Profesor- Humanista. Wybór Pism*, Wydawnictwo Politechniki Poznańskiej, Poznań 2002.
 24. *Każde Miejsce Opowiada Swoją Historię, Czyli Rzecz o Dziedzictwie Wiejskim*, Fundacja Fundusz Współpracy Program AGROLINIA 2000, Poznań 2001, ISBN 83-871116-73-4
 25. *Domy Przystupowe Największym Skarbem Naszego Regionu – Wskazówki Dotyczące Renowacji Domów Przystupowych*.
 26. *Opracowanie Zbiorowe : Carriers of Space Patterns*, Berlin 2010.
 27. *Architektura*, 04(187)Kwiecień 2010, ISSN 1232-6372.
 28. Wojtkun Grzegorz, *Osiedle Mieszkaniowe W Strukturze Miasta XX wieku*, Politechnika Szczecińska, Wydział Budownictwa I Architektury, Szczecin 2004.
- Internet Sources:**
- A** http://www.e-bogatynia.pl/index.php?option=com_content&task=category§ionid=12&id=123&Itemid=506
- B** http://pl.wikipedia.org/wiki/Wigancice_%C5%BBytawskie
- C** http://www.e-bogatynia.pl/index.php?option=com_content&task=view&id=148&Itemid=506 iatam:d
- D** <http://old.kwbturow.com.pl/index.php?dzid=28&did=1652>
- E** <http://gmina.bogatynia.sisco.info/?id=3859>
- F** <http://maps.google.com/>
- G** <http://www.iop.krakow.pl/pckz/opis.asp?id=127&je=pl>
- H** http://www.google.pl/url?sa=t&source=web&cd=1&ved=0CBYQhglwAA&url=http%3A%2F%2Fbip.bogatynia.pl%2F%3Fp%3Ddocument%26action%3Dsave%26id%3D1238%26bar_id%3D1619&rct=j&q=Studium%20Uwarunkowa%C5%84%20i%20Kierunk%C3%B3wBogatynia&ei=mXyITeTAeciUoanpCsL&usq=AFQjCNF9lhMjBRTKt7aeArUWCx6RRZQrZQ&sig=2=GjIw9FLOcV QdxylSsNnl8w&cad=rja
- I** <http://www.bsrr.eu/dzien-otwarty-domow-przyslupowych.html>
- J** http://umowo.opole.pl/docs/ver_pl.pdf
- K** <http://gmina.bogatynia.sisco.info/?id=3859>
- L** <http://www.thangmaker.com/floors.htm>
- M** http://www.ochronaklimatu.com/attachments/205_Feed-in%20tariff%20w%20Polsce.pdf
- N** <http://www.cohabitat.net/>
- O** <http://www.scribd.com/doc/45163928/Bn-62-6738-01-Masy-Cementowo-Gliniane-z-Wypelniaczami>
- P** <http://isap.sejm.gov.pl/DetailsServlet?id=WDU20020750690>
- R** soltechenergy.com
- S** http://www.ogrzewnictwo.pl/index.php?akt_cms=5919&cms=293
- T** <http://www.ennergo.pl/oze-w-budownictwie/energia-soneczna/468-obalamy-mity-na-temat-fotowoltaiki.html>
- U** <http://www.iop.krakow.pl/pckz/opis.asp?id=127&je=pl>
- W** <http://pl.wikipedia.org/wiki/%C5%BBubro%C5%84>