

# MEXICAN - MAYAN COOK BOOK

by

Alejandra Bolles

Milford, CT

2011



In Loving Memory of

Alejandra Kim Bolles

February 26, 1938 – September 22, 2011

Head Chef of the Three Stones Restaurant

A Great Teacher of the Mayan Language,  
Culture, and Way of Life.

Copyright © 2009 by Alejandra Bolles

All rights reserved. No part of this book may be reproduced in any form without  
permission of the author.

## Table of Contents

---

Introductory Remarks	1-10
Description of a Mayan House	1
Mayan Kitchen	2
Cooking Utensils	2-3
Methods of Cooking Food	3-4
Cichcelem Gracia	5
The Preparation of Zacan	5-6
Making Tortillas from Zacan	6-7
Masa Harina	7
An Alternative Method to Shaping Tortillas	8
Store-bought Tortillas and Taco Shells	8
The Story of Keyem	9
Meals of the Maya Throughout a Typical Day	9-10
The Eclectic Maya	10
Tortillas and Things Made From Basic Corn Dough	11-25
Uah	13
Zal buth	13
U Uahil Pol Can	13
Pol Can	14
Quesadillas	14
Enpanadas de Pepita y Espinaca	15
Enpanadas de Pepita y Frijoles	15
Zicil Uah	16
Pimpim Uah	16
Pimes	16-17
Pimes con Chicarrón o Frijoles	17
Ppichil Ichil Cho	18
Panuchos	19
Whole Wheat Tortillas	19
Horoch	20
Horoch yetel Chay	20
Enchiladas	21
Codzitos	21
Tamal	22-23
Huybil Tamal	24
Tacos	25
Sopes	26
Iz Uah	26
Brazo de Reina	26
Sauces	27-33
Ppac yetel Ic (Hot Tomato Sauce)	29
Kelbil Ppac yetel Ic (Roasted Hot Tomato Sauce)	29
Zicil Ppac (Tomatoes with Pumpkin Seeds)	30

## Table of Contents

---

Salsa Verde	30
Cut Ic (Red Chili Sauce)	31
Guacamole (Avocado Sauce)	31
Kuxub (Achiote Coloring)	32
Kuxub yetel Pimienta (Peppered Achiote Coloring)	32
Onzicil de Repollo	33
Meat Fillings and Meat Dishes	35-42
Tzahbil Huchbil Bak (Beef Taco Filling)	37
Picadillo	37
Chimole yetel u Bakil Uacax (Chimole made with Beef)	38
Fajitas	38
Albondigas	39
Carne con Verduras (Meat and Vegetable Soup)	40
Bistec (Beefsteak)	40
Chili con Carne	41
Pork or Chicken with Tomatillos	41
Pibil Keken (Barbequed Pork)	42
Pollo Abobado (Chicken in Adobo Sauce)	42
Poc Chuc X-Cax (Broiled Chicken)	43
Escabeche de Pollo (Pickled Chicken)	43
Mole Poblano	44
Pollo Alcaparrado (Caper Casserole)	45
Empanizado de Pollo (Breaded Chicken)	45
Empanizado de Pescado (Breaded Fish)	46
Chacbil Cay (Fish Soup)	46
Camarones Fritos (Fried Shrimp)	47
Beans and Bean Dishes	49-52
Buil (Boiled Beans)	51
Tzahbil Buil (Refried Beans)	51
Potaje de Frijoles Rojos	52
Lentil Soup	52
Egg Dishes	53-59
Tzahbil He (Fried Eggs)	55
Huevos Rancheros (Rancher's Eggs)	55
Huevos a la Mexicana (Mexican Eggs)	55
Huevos Motuleños (Eggs done in the Motul Style)	56
Chay yetel He (Chaya and Eggs)	56
Onzicil He (Rolled Tortillas with Eggs)	57
Caballero Pobre	58
Chili Relleno (Stuffed Chilies)	59

## Table of Contents

---

Salads and Fresh Vegetable Dishes	61-64
Ensalada de Pepino (Cucumber Salad)	63
Cebolla Curtida (Pickled Onion)	63
Salpicon de Rabanos Rojos (Red Radish Salad)	63
Ensalada de Tomates (Tomato Salad)	64
Rice Dishes	65-67
Arroz a la Mexicana (Mexican Rice)	67
For Mayans Only	69-91
Tu He (Rotten Eggs)	71
Tzahbil Xux (Fried Wasp Larva)	71
Pocbil Huh (Roasted Iguana)	72
Pocbil Chich (Roasted Bird)	73
The Story of Mam Inéz	73-74
Oxil Uah (Breadnut Tortilla)	75
Kelbil Ic (Chimole Paste)	76
Chimol yetel u Bakil Ulum (Chimole made with Turkey)	77
Fiesta!	77-80
U Hanal Alancil (Foods given to the Mother of a New Born Baby)	81-84
Chucua yetel He (Hot Chocolate with Eggs)	82
Chacbil X-Cax (Boiled Chicken)	83
Pocbil He (Roasted Eggs)	84
Pib (Barbecue)	85-60
Finados	85-86
Pibil Keken ((Barbecued Pig)	87
Pibil Nal (Barbecued Corn)	87
Pibil Ceh (Barbecued Venison)	88
Tzicbil Ceh (Shredded Venison)	88
Chilaquil de Venado (Venison in Chili Sauce)	89
Onzicil Ceh (Venison in Pumpkin Seed Sauce)	89
U Tunichil Ceh (The Deer Stone or Bezoar)	90
Sopa de Yucca (Yucca Soup)	91
Pancakes and Pan Fried Dishes	93-97
Sweet Corn Pancakes	95
Squash Pancakes	95
Tortillas de Calabaza (Zucchini Squash Pancakes)	96
Tortas de Berenjena (Eggplant Pancakes)	96
Torrejas (Banana Fritters)	97
Platanos Fritos (Fried Bananas)	97

## Table of Contents

---

Pastries	99-102
Pastelitos de Calabaza (Squash Pastry)	101
Pastelitos de Coco (Coconut Pastry)	102
Desserts and Snacks	103-109
Buñuelos (Jesus' Belly Buttons)	105
Queso Napolitano (Neapolitan Cheese)	106
Flan Napolitano (Neapolitan Custard)	106
Flan	107
Chooch (A Mayan Fruit)	107
Cremas de Coco (Coconut Cream)	108
Kelbil Ixim (Pop Corn)	108
Pocbil Pich (Roasted Pich)	108
Macal (Yautia)	109
Dzim (Yuca Fries)	109
Drinks	111-123
Drinks made from corn	113-119
Za (Fresh Sweet Corn Drink)	113
Zaca Za (A Drink Made From Dried Corn)	113
Zaca (Boiled Dried Corn Drink)	114
Keyem (Another Boiled Dried Corn Drink)	115-117
Iz Ul (Camote Atole)	118
Iz yetel Za (Camote and Atole)	118
Tumben Za (New Atole)	118
Pinol (Another Boiled Dried Corn Drink)	119
Ualak (A Drink made from Pimpim Uah)	119
Chucua (Hot Chocolate)	120
Fruit Drinks	121-123
U Hahil Sandia (Watermelon Drink)	121
Liquado de Sandia (Another Watermelon Drink)	122
Platano con Leche (Banana Milk)	122
Piña Colada	122
Drinks made from rice	123
Horchata (Rice Drink)	123
Arroz con Leche (Rice with Milk)	123

## **A Note About My Life**

I was born in 1938 from a Mayan Indian mother and a Korean father in a place called Ticul which is a Mayan Indian town situated in the Yucatan peninsula.

My parents were very poor which was not strange to me because everybody I knew was the same. As a matter of fact I thought that we were well off because we had a taco stand at the railroad station nearby. There were two trains coming in everyday, one at seven in the morning and the other at four in the afternoon. The taco stand business was very hard because everything had to be ready for the arrival of the trains, and because the train only stayed at the station for twenty minutes, therefore you had to try to sell everything in this period of time. Most of the time there was a lot of food left over which I thought was great because then we could eat as much as we wanted.

The preparation of the food for the taco stand took all day. Most of the work had to be done by me and my older brother because we were the oldest. My mother was not strong enough to help because she was always pregnant. She had a new baby every other year until we got to be eleven children not counting the miscarriages.

There was a person in my life that helped in the shaping of my personality and beliefs. This was my Mayan Indian grandmother. Grandmother was a very down to earth woman. She helped me against my mother's rage when I burned the beans or when the chores were not done when my mother wanted them to be done.

There are two languages spoken in Yucatan, Spanish and Mayan. Grandmother spoke only Mayan whereas my mother would speak to us in Spanish. Therefore I grew up speaking both languages.

Grandmother taught me how to cook in a very primitive way with almost no utensils. We improvised for things that we didn't have. For example we used banana leaves for plates, flat limestone rocks to grind spices or sticks for stirring the food.

Grandmother never let the fire die out. She would bury the fattest ember in the ashes and miraculously the next morning uncovered it and start the fire all over again.

Because there was so much to do and so many babies to take care I only got to second grade which I failed because of so many absences. Then a Gringo from California married me and brought me to New Hampshire. I thought that I was going to loose my mind. There was nothing to do. All I had to do was to touch a button and the chores were done. Well, David the Gringo is very smart. He did not want an hysterical wife so he sent me to college and now I hold a Bachelor of Fine Arts degree.

Presently because the machines are still here to do my chores I continue taking art classes and go sailing with David on the weekends.

Alejandra Bolles





# MEXICAN - MAYAN COOK BOOK

\*\*\*\*\*

## A DESCRIPTION OF A MAYAN HOUSE

For at least the last four thousand years according to archaeological records Mayan houses have remained the same. In fact it is only now in the last part of this century that we are beginning to see houses of different shapes and dimensions.

The main part of a Mayan house is an oval shaped thatched structure which is 2 to 3 meters wide and 4 to 6 meters long. The only openings into the house are the front and back doors. This one room house is during the day used as the living room and then during the night as the sleeping room. There is no privacy for the various members of the family. Usually in the round end to the left of the front door there is a table which has a cross on it. Under, on, and around this table are stored the personal effects of the family members, usually in trunks or other suitable boxes. In the round end to the right of the front door is where the afternoon baths are taken, and thus there is very little there because otherwise these things would get wet.

For a photo of a kitchen or **koben** see page 26.

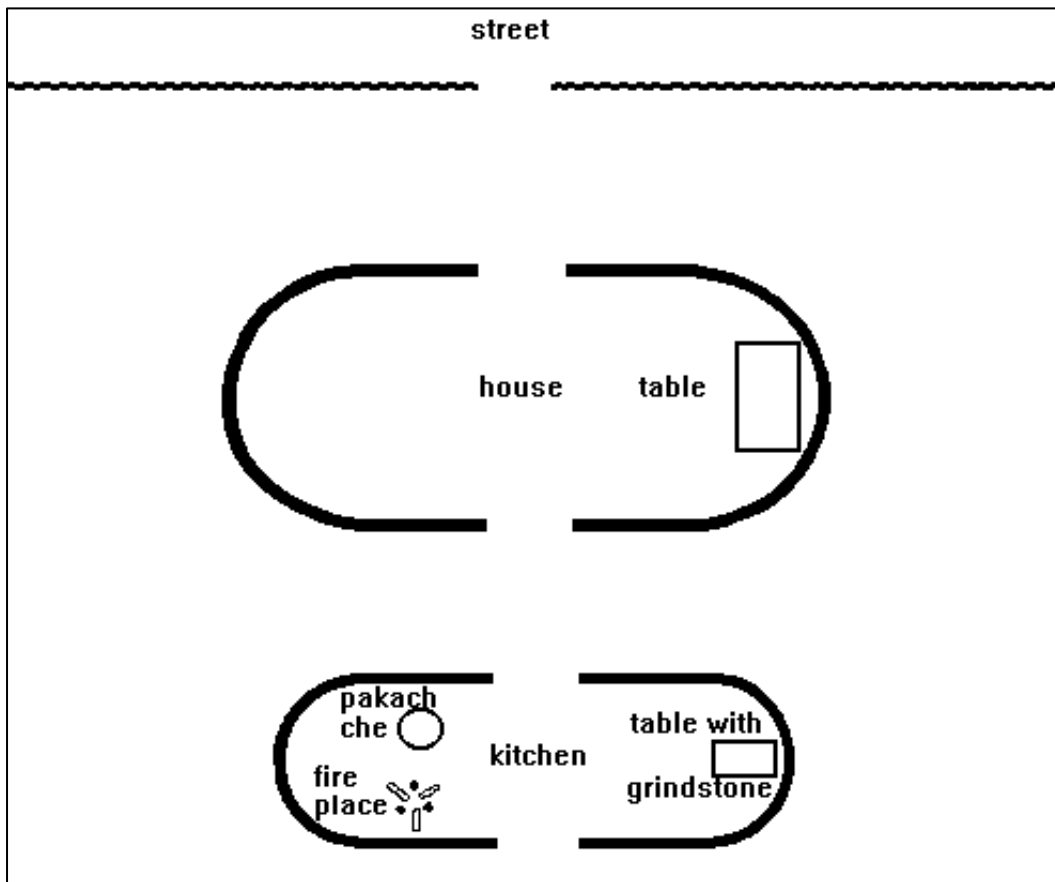

## MEXICAN - MAYAN COOK BOOK

\*\*\*\*\*

### THE MAYAN KITCHEN

In many of the households the only other structure is the kitchen called **koben** in Mayan. The Mayan kitchen is very rudimentary. In its basic form it consists of three stones on which the cooking utensil (a pot or griddle) can be placed with enough room underneath it so that a fire can be built using two to four inch thick sticks for fuel. The cooking area is usually covered by a thatched roofed structure, the walls of which are normally made of sticks so that the smoke can blow out. The cooking area is typically directly behind the rear door of the main house but also usually some meters away from the main house. This is so that the rest of the living space does not get smoked up.

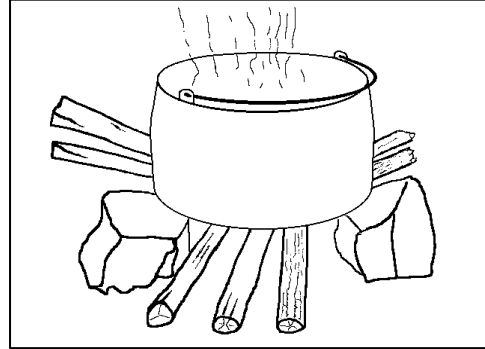

### COOKING UTENSILS

The two most important cooking utensils are the **cum** (pot) and the **xamach** (a clay or metal frying pan, called “comal” in Spanish, a word borrow from the Aztecs). There are usually at least two pots, one used preparing the corn to make tortillas and the other to cook the daily ration of beans. There is a ladle or two for stirring and serving the foods cooked in the pots, kitchen knives, and perhaps a grate on which things are placed to be roasted over the fire. Other items to be found in the **koben** are the **pakach che**, a low round table on which the tortillas are made, and a waist-high table on which is to be found the **ca**, the grind stone used to make the tortilla dough, a **molcajete** (from the Aztec word “molcaxitl”), a mortar with its pestle made of volcanic rock, and a **bokob che** or **bokob xuthen**, called “batidor” in Spanish, a wooden vessel in which hot chocolate is made. Stacked in boxes or perhaps on the table are the eating utensils: spoons, soup plates, dishes, and gourds of the *Crescentia cujete* tree cut in half called **luch**, which serve as cups.

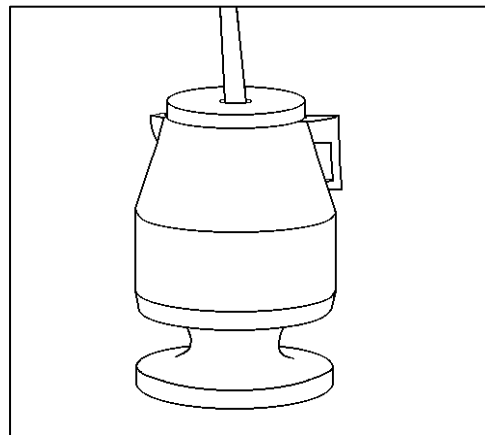
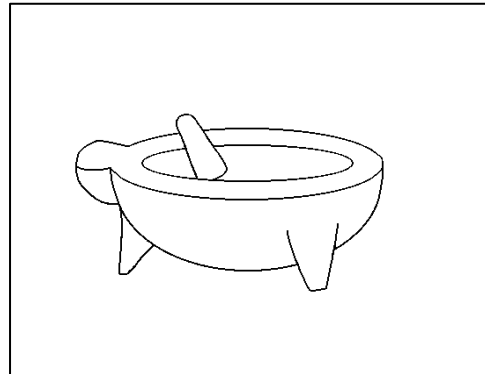

## MEXICAN - MAYAN COOK BOOK

\*\*\*\*\*

### METHODS OF COOKING FOOD

There are a variety of terms which are used in the names of the recipes given in this book which describe the way the food has been prepared. A list of these terms is given here so that you will know the meaning of these terms and also so that you will be able to approximate in your kitchen the original method of cooking the food. Most of the terms end in the grammatical suffix **-bil**, which is much like the English grammatical suffix “-ed”. (baked, boiled, broiled, cooked, roasted, etc.) Some of the terms are self-explanatory. For those which are unusual an explanation is given.

**chacbil**: boiled.

**huchbil**: ground. The verb **huch** is a general purpose verb meaning to grind or to mill. When the verb **huch** is applied to meat we use the verb “to grind”, but when it is applied to the grinding of corn or other grains we often use the verb “to mill”. Ground meat (hamburger) is called **huchbil bak**.

**huybil**: stirred.

**kakbil**: broiled. This is done by placing the food, usually meat, directly on the fire or alternatively by placing it on a grill over the fire.

**kelbil**: toasted. This is done by placing the food to be toasted in a frying pan or saucepan and heating it on the fire. The connotation of **kelbil** is that of toasting or frying dry foods such as pumpkin seeds, popcorn, etc., versus **tzahbil** which is the frying of moist foods such as eggs, meat, etc.

**pibil**: barbecued. This is done by placing the food, wrapped in some protective covering such as banana leaves or corn leaves, in a hot fire pit. The fire pit is prepared by digging a hole, about 1 meter square and ½ meter deep, in the ground. The hole is then filled up with firewood and the fire is lit. As the fire burns moderate sized rocks (about 4 to 8 inches in diameter) are placed on the fire. When the fire has burnt itself out so that all is left are the hot rocks then the food is placed on top of the hot rocks. So that the food does not get scorched it is placed in old tins. On top of the food is placed a layer of boughs topped by banana leaves over which are placed wet gunny sacks and finally a layer of dirt to keep the heat in. Cooking time is usually two to three hours.

**poc chuc**: charcoal broiled. This is done by placing the food, usually meat, directly on charcoal (**chuc** in Mayan) or alternatively by placing it on a grill over the charcoal.

**pocbil**: baked / roasted. This is done by placing the food, wrapped in some protective covering if necessary, in hot ashes. Normally a hole is hallowed out in the ashes next to the kitchen fire, the food placed in the hole, and then hot ashes and coals from the fire are raked over the food.

**tzahbil**: fried. As noted above in **kelbil**, this means that the food to be fried is moist, such as eggs, meat, etc., and thus this what we would normally understand as “fried”.

## MEXICAN - MAYAN COOK BOOK

\*\*\*\*\*

**tzicbil**: shredded. This term is usually applied to meat which is pulled apart into strands. The meat is cooked first in any of the methods described here. The meat then shredded **tzicbil** is place in a serving dish.

**youoxbil**: steamed. A pot with about 2 inches of water is put on the the fire and the water is brought to a boil. The food to be cooked is placed in a colander which is held just above the water level and left there to be cooked by the steam.

The only two cooking methods listed here which are hard to duplicate in a modern kitchen are **pibil** (barbecued) and **pocbil** (baked). To duplicate the food cooked **pibil** is difficult because the leaves impart a special aroma to the food and also the steam from the cooked boughs keeps the food moist as well. The foods cooked **pocbil** also do not seem to dry out as much as they would if they are cooked in a normal oven, perhaps because they must be wrapped in order to be protected from the ashes and thus conversely keep the moisture of the food from evaporating.



Making charcoal or **chuc**.

## MEXICAN - MAYAN COOK BOOK

\*\*\*\*\*

### CICHCELEM GRACIA

(“Holy Grace”, the reverential name for Corn)

Beans (**buul**) and corn (**ixim**) are the two grains which are the mainstays of the Mayan diet. As the Mayans jokingly say to each other: “What are you going to eat today?” “Tortillas and beans.” “And what are you going to eat tomorrow?” “Beans and tortillas.” Despite the importance of beans in providing the necessary proteins for bodily functions, it is corn which receives the most attention both in the number of ways it is prepared and also in terms of the agricultural rituals which are still carried on throughout the Mayan world during the corn growing season.

When I was little we did almost all of the preparation of **zacan** ourselves. **Zacan**, called “masa” in Spanish, is the Mayan word for the corn dough from which **uah**, tortillas, are made. The hardest part of this process is grinding the cooked corn to make the **zacan** by hand. Then from the 1930’s through the 1950’s power-driven mills began to become common in all but the smallest towns in Yucatan and it became common to take the cooked corn called **kuum** down to the mills to get it ground. **Kuum** is the unground cooked corn called “nixtamal” in Spanish, a word borrowed from the Aztecs. Outside the mill there would be a line of girls and women awaiting their turn to get their **kuum** ground. Of course this became the social hour when everybody could catch up on the latest gossip, and the young girls, who before hated the drudgery of grinding the corn, were more than happy to have the “chore” of going to the mill. Then as people became a little more affluent they began to buy the **zacan** already cooked and ground by the mill, and so only the actual making and cooking of the tortillas was done in the houses which could afford the luxury of buying the ready-made **zacan**. Now however people have become even more affluent (relatively speaking) and now they buy ready-made tortillas at the mill, much to the disgust of the traditionalists who say, and rightly so, that machine-made tortillas just don’t have the flavor of hand-made tortillas. For those people living in far off places the traditional methods of making tortillas is still carried on because there is no other choice, and in fact if all the mills and tortilla machines came to a grinding halt tomorrow life would go on without much comment because most of us still have the skills to make tortillas directly from corn.

### THE PREPARATION OF ZACAN

While it is not expected of the reader to make **zacan** the Mayan way from scratch, I feel that it would be good to describe the process so that the reader can see what is involved.

The favored corn for making **zacan** is flint corn. If the family raises its own corn then usually the corn is stored on the cob. The corn is first shelled and then cleaned of all foreign particles. Even if the corn is store-bought it still has to be cleaned. A pot with about 10 cups of water is put on the fire to boil and then a cup of slake lime is poured into it. After the lime has dissolved then 3 cups of corn is poured in. The

## MEXICAN - MAYAN COOK BOOK

\*\*\*\*\*

corn is cooked for five minutes and then the pot is taken off the fire and allowed to set overnight. The grains of corn swell up and the skin or hull both dissolves and flakes off. In the morning the corn is washed several times to get rid of the lime and the hulls. This is done until the water does not pick up any more lime or hulls. At this point the corn is called **kuum** and is ready for grinding. In one corner of the kitchen there is a very sturdy table on which is placed the **ca** (grind stone, called “metate” in Spanish, another word borrowed from the Aztecs). Handful by handful of corn is ground to a fine paste. The resulting **zacan** is now ready for making **uah** (tortillas). There are several variations on this method of preparing corn for making yet other corn preparations, such as a drink called **keyem** (“pozole” in Spanish, also a word borrowed from the Aztecs), and these variations will be discussed in the recipes for these other preparations.

### MAKING TORTILLAS FROM ZACAN

Once the **zacan** is ready then the tortillas are made. The fire is prepared so it will burn fairly hot. On the three stones is placed the **xamach**. When I was little we used banana leaves as a backing on which to form the tortillas, but now sheets of plastic are used. A golf ball sized ball of **zacan** is patted flat to about ½ inch thick between the two hands, making a pok-a-pok-a-pok noise. Then the flatten ball is placed on the banana leaf on a small circular table called **pakach che** or “banqueta” in Spanish and patted out with the hands, the left hand doing the patting while the right hand guides the tortilla round and round. When the tortilla is almost ready it is given some addition pats with the right hand making a distinct resounding noise. Throughout the town this is going on from about 11 am to 12 noon, and as one goes by the houses one hears pok-a-pok-a-pok and then a few moments later pat-pat-pat-PAT. The action of making tortillas is called **pakach**. The tortilla is then immediately placed on the **xamach** and cooked for about 10 seconds on each side. When the tortilla is cooked properly it will puff up forming what is called a **zay**, usually

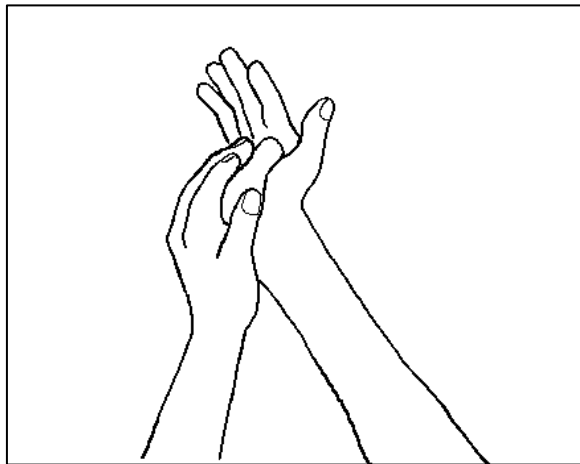
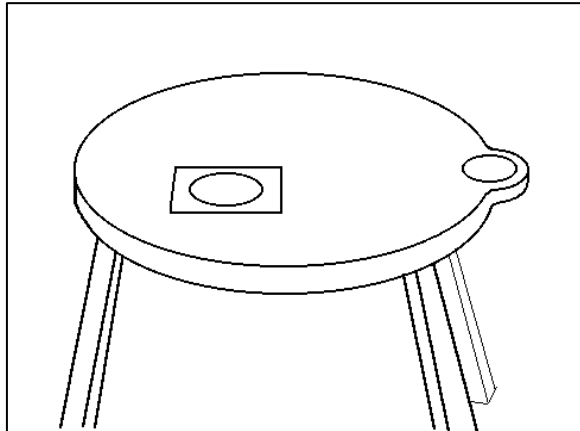

## MEXICAN - MAYAN COOK BOOK

\*\*\*\*\*

after being pressed by a rag held in the hand. The cooked tortillas are immediately stuffed into a large gourd called **lec**, which is used because it has a thick rind which acts both as insulating material to keep the tortillas hot and as an absorbent material to suck up the excess water vapor which is given off by the hot tortillas.

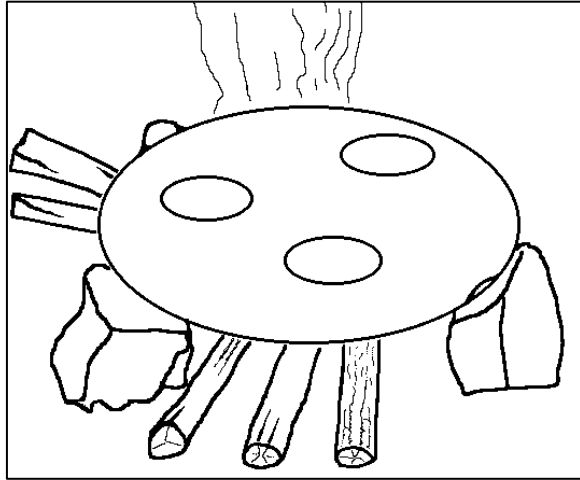

### MASA HARINA

When I first arrived in the U.S. I had a hard time finding the necessary ingredients for making tortillas. The corn which is available here is mostly a dent variety meant for cattle feed and just does not taste the same. However, the Quaker Oats Company has come to the rescue and makes a prepared corn flour called Masa Harina. When reconstituted with water it is very much like the **zacan** which we used to make, and in fact is much better than the **zacan** bought at the mills in Yucatan, in part because the mills tend to over-cook the corn and furthermore don't take the time necessary to wash the **kuum** properly. Thus there is a distinct aftertaste of the slake lime left in the **zacan** made by the mills. Fortunately the Quaker Oats Company has a process in preparing their Masa Harina which avoids this unpleasant aftertaste.

In the recipes given here it is presumed that all of the various **zacan** preparations are made by using Masa Harina or some equivalent corn flour which is prepared especially for making tortillas. Straight uncooked ground corn is not a substitute, because it has not been processed by being pre-cooked.

## MEXICAN - MAYAN COOK BOOK

\*\*\*\*\*

### AN ALTERNATIVE METHOD TO SHAPING TORTILLAS

I have mentioned above how tortillas are made by the Maya. However, this takes some practice and in fact my Grandmother always said that a girl is not ready to get married unless she knows how to make tortillas and **Cut Ic** (red or green chili sauce). (I knew how to make tortillas and **Cut Ic** by the time I was fourteen, but still didn't get married until I was thirty!) There are several alternative ways for making tortillas from **zacan**, some involving a tortilla press. The most basic way however is to cut out two plastic sheets from something like a food storage bag. These sheets should be about 8 by 8 inches square. On a good flat surface place a golf ball sized ball of dough on one of the sheets and place the other sheet over it. Then take a suitable plate, for example a glass pie plate, and squeeze the ball into a tortilla about 4 inches in diameter and 3/16 inch thick. The thickness is more important than the diameter, because tortillas which are too thin don't puff up into the **zay** and tortillas which are too thick don't cook through properly. Make sure to use the same sides of the plastic sheets for making the tortillas, or else a residue of **zacan** will start to build up on the pie plate and on the table.

If you are not standing right by the stove while forming the tortillas to cook them as you make them you can stack the uncooked tortillas by using paper towels. Place a paper towel on a tray and then put four tortillas on the towel. Then cover the tortillas with another paper towel and make another four tortillas, etc. Make certain that the tortillas are not touching each other, because if they are they will glue themselves together and you will have to make them over again.

Since **lec** gourds are not available here in the U.S. a good alternative to storing the tortillas until they are served is to place a couple of layers of dish towels on a tray and stack the tortillas on them. Then when you are finished making the tortillas fold the towels over the top of the stack of tortillas. This will keep them warm until they are served.

### STORE BOUGHT TORTILLAS AND TACO SHELLS

Of course you can buy tortillas and dried taco shells in many markets today throughout the U.S., but again it is a question of taste. There simply is no substitute for freshly made tortillas, and of course for such dishes as tamales you need to have **zacan** as the basis from which you start.



## MEXICAN - MAYAN COOK BOOK

\*\*\*\*\*

### THE STORY OF KUUM

Long ago when the world was young all things had feelings and emotions, even a grain of corn. The old people say that enough **kuum** used to be made from a single grain of corn put into the pot of boiling water. This grain of corn had the task of multiplying itself while the **kuum** was cooking until the pot was full. Then one day the daughter-in-law said to herself, "It is silly to make the **kuum** this way and wait for the corn grain to multiply itself until the pot is full. I think that it will be faster if I fill the pot with corn and get it over with." So she poured in many more grains of corn and set the pot to boil again. Now the first grain of corn got confused because there was no room in the pot for it to multiply, so it said to itself, "Since this silly daughter-in-law wants to do my work for me then I will just lie down here and not do any work anymore."

The next morning when the Grandmother put the grain of corn in the pot the grain of corn did not do anything. The Grandmother asked the grain of corn, "What has come over you, little corn? Why don't you multiply?" The grain of corn told her what the daughter-in-law had done. The Grandmother then said, "But little corn! It is not fair that the whole of mankind will suffer just because of the silliness of one granddaughter." The grain of corn said, "Grandmother, I understand what you say, but I can not go back to the old way because I like the easy life I have now. But I will compromise with you because you are old and wise. You only have to fill the pot half full and I will swell myself to fill it the rest of the way." And this is the way the **kuum** is still made today.

### MEALS OF THE MAYA THROUGHOUT A TYPICAL DAY

People usually wake up at 4 or 5 in the morning so that the men can be at work at daybreak. Breakfast consists of hot chocolate and tortillas, either those left over from the day before or some freshly made tortillas made from **zacan** which was not used up.

The men take with them balls of **keyem** (over-cooked **zacan**) from which they make a drink also called **keyem** at about 11 a.m. At about this time at home the process of making tortillas is beginning and the women and children will drink **ualak**, which is made by mushing a thick tortilla called **pimpim uah** in water, or they will munch on the tortillas as they are being made.

The men return from work at about 2 p.m. and after taking their baths the main meal is served. As noted earlier, the meal almost always consists of tortillas and beans. Should someone come across some animal while they are going about their work and kill it then that is prepared for the meal as well, or should there be enough money and the village butcher or some private family have meat for sale then that is cooked with the beans. Or if the family chickens have done their duty for the day then there will be some egg dish to supplement the tortillas and beans routine.

## MEXICAN - MAYAN COOK BOOK

\*\*\*\*\*

Around 6 or 7 p.m. the final meal of the day is eaten. It consists of chocolate and tortillas again, but with perhaps some of the left-overs from the mid-day meal being also consumed.

### THE ECLECTIC MAYA

The reader will notice that some of the names of the recipes given in this book are Mayan while others are Spanish. For me, that is the way things are, and most probably reflects the fact that, first of all, I grew up in a house which was caught between the Mayan and Mexican cultures. As added spice, there was also considerable influence from the Korean culture, my father being completely Korean and my mother's father also being Korean. However, it was my mother's mother, who was pure Mayan, who had the most influence in our house, since she lived with us, whereas I had much less contact with my father's parents who lived in the big city of Mérida.

My Grandmother was my primary teacher of everything having to do with life. My father was almost never home since he was off on "business trips" (we never knew what these trips really amounted to) and my mother was invariably pregnant and thus lying down in her hammock. It thus fell to my Grandmother to keep the house running, and since I was the oldest daughter it was my duty to help her in performing many of the tasks of running the house. Fortunately, she made these tasks very enjoyable for me, and was a kindly teacher. Since she could not speak any Spanish, all of our conversations were in Mayan, and thus of course my knowledge of the names of various foods came from the Mayan way of naming them. Added to this is the fact that I was brought up in Ticul, a city which proudly proclaims itself as being "The Biggest Mayan City in the World". Thus, I was surrounded by the Mayan language and Mayan culture in my formative years.

The question can rightly be asked why do some foods have Mayan names and others have Spanish names, even for Mayan speakers. I can only surmise that those items which have Spanish names were not originally part of the Mayan cuisine, and that when they were adopted by the Maya that the Spanish, or in many cases, the Aztec names came along with the food items. Actually, this phenomenon also exists for the Spanish speaking population of Yucatan as well, where many food items have Mayan names, this because there are no adequate Spanish names for these items of food.

TORTILLAS  
and Things Made From  
BASIC CORN DOUGH

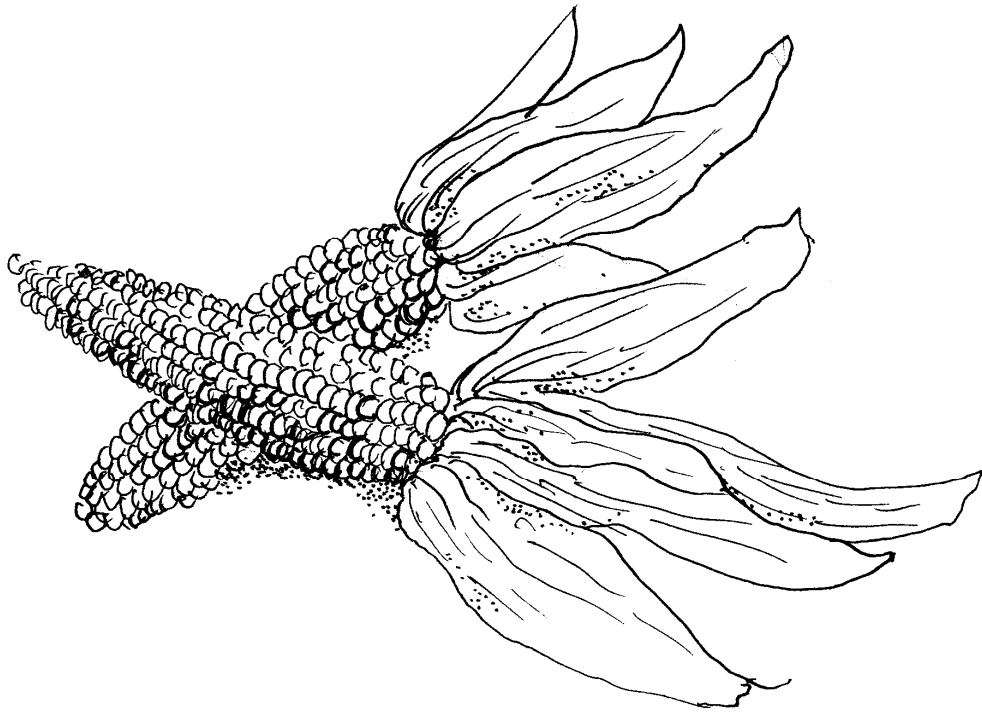



Alejandra making tortillas or **uah**

## MEXICAN - MAYAN COOK BOOK

\*\*\*\*\*

### UAH

---

(Tortillas / Soft Taco Shells)

- 2 cup Masa Harina
- ¼ cup white flour
- 2 cup warm water
- ¼ teaspoon salt

In a large bowl mix all the ingredients together until a soft dough is formed. If the dough is too soft add a little more masa harina. Shape the dough into balls the size of golf balls or bigger if you want big tortillas.

Flatten the balls one by one in between two sheets of plastic until they are 4 inches in diameter. Cook the resulting tortillas on a lightly greased griddle over medium heat for 30 seconds on each side. When the second side is done turn the tortilla a third time and press firmly for about three seconds with a kitchen towel. This will make the tortilla separate into two layers. Some will separate and some will not.

### ZAL BUTH

---

(Deep Fried Taco Shells)

Prepare the tortillas as described above. Then instead of cooking them on a dry griddle deep-fry them in a skillet with about 1 inch of corn oil at high heat for 10 seconds on each side. Then place them vertically in a big colander lined with paper towels to drain the excess oil.

### U UAHIL POL CAN

---

(Special Tortillas for making Pol Canes, Enpanadas,  
and Quesadillas)

- 3 cups Masa Harina
- ¾ cup white flour
- 2 cups warm water
- 2 tablespoon cooking oil
- ½ teaspoon salt

Mix all the ingredients in a large bowl until a soft dough is formed. Shape the dough into balls the size of golf balls. Flatten the balls in between two sheets of plastic until they are 4 inches in diameter. The tortillas are now ready to use in the recipes for Pol Canes, Quesadillas, and Enpanadas.

## MEXICAN - MAYAN COOK BOOK

\*\*\*\*\*

### POL CAN

---

(“Snake Head”, Folded Tortillas with Pumpkin Seed  
and Lima Beans)

- 15 uncooked tortillas
- 1 cup ground pumpkin seeds
- 1 package frozen lima beans
- ½ chili jalapeño, chopped fine
- 1 onion, chopped fine
- salt to taste

Boil the lima beans. Discard the water. Mix with the ground pumpkin seeds, chili jalapeño, chopped onion and salt. Put a spoon-full of mixture in the middle of a tortilla. Fold the tortilla over and seal the edges well. This is now a pol can. Cook on a lightly greased griddle at medium heat and turn constantly until all sides are cooked.

An alternative method of cooking the pol canes is by deep-frying.

Serve with hot tomato sauce and cheese.

### QUESADILLAS

---

(Folded Tortillas with Cheese)

- 15 uncooked tortillas
- ½ pound grated cheese
- 4 cups hot tomato sauce

Put a spoon-full of cheese in the middle of a tortilla. Fold the tortilla over and seal the edges well. This is now a quesadilla. Cook on a griddle at medium heat and turn constantly until all sides are cooked. Place on a platter and pour the hot tomato sauce over each serving.

An alternative method of cooking the quesadillas is by deep-frying.

## MEXICAN - MAYAN COOK BOOK

\*\*\*\*\*

### ENPANADAS DE PEPITA Y ESPINACA

---

(Folded Tortillas with Pumpkin Seed and Spinach)

- 15 uncooked tortillas
- 2 cups ground pumpkin seed
- 1 package frozen spinach
- 1 onion or 1 bunch scallions, chopped
- 1 jalapeño chili pepper, chopped
- salt and black pepper to taste

Mix the ground pumpkin seeds, onion (or scallion), jalapeño chili pepper, spinach, salt and pepper. Put a spoon-full of mixture in the middle of a tortilla. Fold the tortilla over and seal the edges well. This is now an enpanada. Cook on a griddle at medium heat and turn constantly until all sides are cooked.

An alternative method of cooking the enpanadas is by deep-frying.

The Mayan equivalent to spinach is **chay** or “chaya”, a stingless native domesticated nettle (*Jatropha aconitifolia* Mill.). Its leaf is used like spinach in many dishes. Should **chay** be available in your store try using it instead of using spinach.

### ENPANADAS DE PEPITA Y FRIJOLES

---

(Folded Tortillas with Pumpkin Seed and Beans)

- 15 uncooked tortillas
- 2 cups ground pumpkin seed
- 2 cups cooked beans
- 1 onion or 1 bunch scallions, chopped
- 1 jalapeño chili pepper, chopped
- salt and black pepper to taste

Mix the ground pumpkin seeds, onion (or scallion), jalapeño chili pepper, beans, salt and pepper. Put a spoon-full of mixture in the middle of a tortilla. Fold the tortilla over and seal the edges well. This is now an enpanada. Cook on a griddle at medium heat and turn constantly until all sides are cooked.

An alternative method of cooking the enpanadas is by deep-frying.

## MEXICAN - MAYAN COOK BOOK

\*\*\*\*\*

### ZICIL UAH

---

(Pumpkin Seed Tortillas)

- 2 cups Masa Harina
- 1 cup pumpkin seeds
- 1 ½ cups warm water
- ½ teaspoon salt

Mix the Masa Harina, water, and salt. Add the whole pumpkin seeds and mix well. Flatten into regular sized tortillas. Cook on the grill. Do not deep-fry these tortillas.

### PIMPIM UAH

---

(Thick Tortillas)

- 3 cups Masa Harina
- ¾ cup white flour
- 2 cups warm water
- 2 tablespoon cooking oil
- ½ teaspoon salt

Mix all the ingredients in a large bowl until a soft dough is formed. Shape the dough into balls the size of golf balls. Flatten the balls until they are ½ inch thick. Cook the resulting tortillas on an lightly greased griddle over medium-high heat for about 30 seconds on each side. Keep turning until they are cooked through. Top with tomato sauce and cheese and serve.

### PIMES

---

(Thick)

Pimes are fat little tortillas. These tortillas stay very soft and fresh for about three days. Therefore they are very good for traveling.

When I was very young my family liked to go to the nearby towns for the saints' festivities. Some people made these trips on carts pulled by donkeys or horses but people like my family who were too poor to have these animals did the journey on foot.



## MEXICAN - MAYAN COOK BOOK

\*\*\*\*\*

The day before of our journey my Grandmother and I made several kinds of pimes to take with us. On the next day Grandmother would wake us up when she heard the first roosters crowing. She always said, "Wake up children! It is four o'clock in the morning." Since there was no clock in our house I always believed that in fact it was the time Grandmother said it was.

While I helped the children get dressed Grandmother toasted three tortillas until they were almost black and dropped them in hot water. When the tortillas dyed the water Grandmother sweetened it with sugar and gave the children a gourd full of the hot liquid along with a coupled of pimes for breakfast.

At about five in the morning we started walking. There already were groups of people walking along the road. At noon time the sun is too hot for everybody especially for the children. Therefore we all stopped under a tree and had pimes and water for lunch. Sometime the babies took a nap under the trees before resuming the walk. We usually got to where we were going just before dark.

There were always friends or relatives that lived in the towns they went to, so we always had a place to stay. The fiesta usually lasted for three days.

---

### PIMES DE CHICHARRÓN O FRIJOLES

---

(Thick tortillas with pork cracklings or beans)

1 cup pork cracklings or cooked beans  
2 cups masa harina  
¼ cup white all purpose flour  
1 teaspoon salt

In a big bowl mix the masa, the flour, and the salt. Add water little by little until the mixture becomes a soft dough. Crush the crackling into tiny pieces and add this to the masa and and mix well.

Take the amount of two size golf balls of masa and fuse into one. Make little fat tortillas the size of the palm of your hand.

Cook on a comal on top of the stove turning them over until both sides are well done.

Let them cool spread out on a piece of cloth.

Stack them six at a time and wrap them in a cloth napkin

## MEXICAN - MAYAN COOK BOOK

\*\*\*\*\*

### PPICHIL ICHIL CHO

---

(“Pop Eyed Mouse”; a thick tortilla made with Black Beans)

- 3 cups Masa Harina
- $\frac{3}{4}$  cup white flour
- 2 cups warm water
- 2 tablespoon cooking oil, butter, or lard
- $\frac{1}{2}$  teaspoon salt
- 1 cup shell beans or freshly cooked black beans

Mix all the ingredients except the beans in a large bowl until a soft dough is formed. Fold in the beans. Shape the dough into balls the size of golf balls. Flatten the balls until they are  $\frac{3}{8}$  inch thick. Cook the resulting tortillas on a lightly greased griddle over medium-high heat for about 30 seconds on each side. Keep turning until they are cooked through.

Alternatively large tortillas about 8 inches in diameter and thick can be made. Wrapped them in banana leaves or corn leaves. Cook them for about 1 hour either in a steamer or in the oven, or better yet in a **pib**. (See the section “For Mayans Only” for more on cooking in a **pib**.)



## MEXICAN - MAYAN COOK BOOK

\*\*\*\*\*

### PANUCHOS

---

(Tortillas filled with Refried Beans)

There are three ingredients for panuchos: cooked tortillas, refried beans, and a sauce. The recipes for the refried beans and the sauces are given elsewhere in the book. See Table of Contents.

- 15 cooked tortillas
- 1 cup refried beans
- 4 cups hot tomato sauce or 2 cups cebolla curtida
- 1 cup grated cheese

Open up the tortilla to form a pocket and put a spoon-full of refried beans in the middle of a tortilla. This is now a panucho. Warm by deep-frying the panuchos. Place on a platter and pour the hot tomato sauce or cebolla curtida over each serving and garnish with cheese.

### WHOLE WHEAT TORTILLAS

---

(Chapatis)

- 2 cups whole wheat flour
- 1 cup white flour
- 1 cup water
- 3 tablespoons oil
- ½ teaspoon salt

Mix all the ingredients together and knead for a few minutes. Make golf ball sized balls out of the dough. On a well floured board roll out the dough into tortillas. Cook on a lightly oiled griddle like regular tortillas.

Serve with tomato sauce, cheese, refried beans, or whatever suits your fancy.

## MEXICAN - MAYAN COOK BOOK

\*\*\*\*\*

### HOROCH

---

(Dumplings made of Corn Dough)

- 2 cups masa
- 2 tablespoons cooking oil
- 2 cups refried beans
- 1 cup water

In a saucepan mix the refried beans with the water and set on the stove to boil at medium low heat.

Prepare the masa as shown in the recipe for Tortillas. Add the cooking oil to the masa and mix well. Divide the masa into golf ball sized balls. Flatten them into patties about ½ inch thick. Place them into the boiling bean soup one layer at a time. Wait about 1 minute between layers or else the dumplings will stick together. Boil for 20 minutes.

Serve with hot tomato sauce and cheese.

### HOROCH YETEL CHAY

---

(Dumplings and Chaya)

- 2 cups masa
- 2 tablespoons cooking oil
- ½ pound chaya (or spinach)
- 2 round pieces of beef with bone
- 2 garlic cloves
- 12 cups water
- salt and black pepper to taste

In a saucepan put in the chaya (or spinach), beef, garlic, salt, pepper, and water and set on the stove to boil at medium low heat.

Prepare the masa as shown in the recipe for Tortillas. Add the cooking oil to the masa and mix well. Divide the masa into golf ball sized balls. Flatten them into patties about ½ inch thick. When the beef is cooked place the dumplings into the boiling soup one layer at a time. Wait about 1 minute between layers or else the dumplings will stick together. Boil for 20 minutes.

Serve with Salpicon (Red Radish Salad). See chapter on Salads.

## MEXICAN - MAYAN COOK BOOK

\*\*\*\*\*

### ENCHILADAS

---

- 1 pound meat filling (chicken or beef)
- 4 cups red chili sauce
- 15 plain tortillas
- ½ pound grated cheese

Prepare the tortillas as described previously, the meat filling as described in the section on Meat Fillings, and red chili sauce as described in the section on Sauces. Time the preparation of these so they are finished cooking at the same time and thus will be used hot.

In a shallow plate spread about ¼ of the red chili sauce. On a hot tortilla spoon out some beef filling and then roll it up and place it on one end of the plate. Repeat until all of the tortillas are filled. Spread the remaining red chili sauce over the tortillas. Garnish with the cheese and serve.

### CODZITOS

---

(Rolled Tortillas)

- 12 freshly cooked tortillas
- ½ cup shredded beef

Place the shredded beef in the center of the tortilla and roll it tight. Tie the tortilla with a string so that it does not unroll. Let it dry for one day in the refrigerator. Then deep fry in hot oil turning over constantly until golden brown. Drain the **codzitos** by placing them standing vertically in a deep dish or bowl which has several layers of paper towels in the bottom to soak up the oil.

To serve pour your favorite tomato sauce over them and garnish with cheese.

## MEXICAN - MAYAN COOK BOOK

\*\*\*\*\*

### TAMAL

---

There are three steps in making tamales. First the meat filling is prepared. Then a gravy filling is made from the sauce in which the meat was cooked. Finally these fillings for the tamales are combined and wrapped in large uncooked tortillas made from the basic tortilla dough and placed in a steamer to cook.

Step 1:

#### CHICKEN FILLING FOR TAMALES

---

- 1 medium chicken skinned, wash and cut in big pieces.  
(turkey or pork of the same amount can be used instead of chicken)
- 1 big onion, chopped fine
- 1 big tomato chopped
- 1 sweet green pepper, chopped fine
- 4 big cloves of garlic, chopped fine
- ½ cup of achiote coloring
- 3 ½ cups water
- salt and black pepper to taste

In a big saucepan combine all ingredients. Add water. Cook at medium high heat until the meat is tender. Let cool for about 30 minutes. Remove the chicken from the broth. Separate the chicken meat from the bones, discarding this. Save the broth for the gravy filling.

Step 2:

#### GRAVY FILLING FOR TAMALES

---

- 3 cups of cool chicken broth
- ½ cup of white flour (not sifted)
- ½ cup masa harina flour
- 1 teaspoon salt
- ½ cup cooking oil

In a big saucepan combine all ingredients and mix well until the flour is diluted into the broth. Cook on top of the stove at medium heat stirring constantly until the resulting gravy starts to thicken. When it starts boiling. Turn off the heat and keep stirring until the sauce stops boiling. Set the sauce aside to cool.

## MEXICAN - MAYAN COOK BOOK

\*\*\*\*\*

Step 3:

### ASSEMBLING THE TAMALES

---

4 cups masa harina  
1 ½ cup white flour  
1 teaspoon salt  
¾ cup cooking oil  
3 cups water

Corn husks or banana leaves to wrap the tamales.

Soak the cornhusks overnight or boil them for 3 minutes to soften them. When cool wash each leaf in running water. Set aside. Alternatively banana leaves, available in the freezer section in specialty stores, may be used as wrappers. Thaw the leaves and clean using a moist soft rag or paper towel. Cut into about 14" long sections.

Assembling the tamales.

Make the masa from the above ingredients. Divide the masa into golf ball sized balls. Take two balls and make one large one out of them. Place one ball in between two pieces of clear plastic sheets. Flatten the ball into a large tortilla with a glass pie plate. Keep the flattened tortillas on the bottom sheet of the plastic until all the tortillas are done.

Place a tablespoon of gravy filling on one of the tortillas and put some chicken meat horizontally in the middle. Pour another tablespoon of gravy sauce on top. Fold two flaps of the tortilla over the filling and then fold over the two end flaps.

Put two pieces of corn husk together and place the tamale in the middle, or, if banana leaves are being used, in the middle of the banana leaf. Discard the plastic and wrap tightly. Repeat until all tamales are made. Put into a steamer and cook for 45 minutes to an hour. Tamales can also be baked in the oven at 375° for 45 minutes to an hour.

Alternatively, large tamale pies can be made. Form a large thick tortilla, about 8 to 12 inches in diameter and ½ inch thick. Make an edge around it about ¾ inch high. This is more easily done in a pie plate or some equivalent baking dish. Place in pieces of chicken and pour in the filling to about ½ inch thick. Now make another ½ inch thick tortilla and cover the pie. Seal the cover tortilla to the bottom tortilla. Wrap in banana leaves and cook for about 1 hour either in a steamer or in an oven, or better yet in a **pib**. (See the section "For Mayans Only" for more on cooking in a **pib**.)

### Memories

A long time ago when I was a child there were no cars, so my family and I would travel to nearby villages on foot. Sometimes we would walk all day in the Yucatecan heat to get to where we were going. Tamales were perfect for these trips because they are good to eat hot or cold. It was common to see other families along the road sitting under a shady tree and having a picnic at noon.

## MEXICAN - MAYAN COOK BOOK

\*\*\*\*\*

### HUYBIL TAMAL

---

The first two steps for making Huybil Tamal (stirred tamale) are the same as that for making regular tamales and are given in Steps 1 and 2 for making tamale filling on the previous pages. However, the Huybil Tamal has a softer shell as the name implies.

The steps for making the shell for the Huybil Tamal are as follows:

Ingredients:

1 ½ cup Masa Harina  
1 ½ cup flour  
1 ½ cup oil  
7-8 cups water

Mix the ingredients and place in a sauce pan. Simmer stirring constantly until the sauce thickens. Spread the sauce evenly onto a greased baking pan and let cool. Cut into 4" squares and make an indentation in the middle of each piece.

Put a few pieces of meat in the indentation and then cover with **kol**. Wrap in banana leaves and steam for 50 minutes.



Alejandra in front of her kitchen or **koben**  
in Kom Cheen, Yucatan



## MEXICAN - MAYAN COOK BOOK

\*\*\*\*\*



### TACOS

---

Step 1: Make tortillas as directed on page 13.

Step 2: Make tomato sauce as directed on page 29.

Step 3: Make the taco filling as follows:

1 pound of ground beef or turkey  
1 medium onion chopped fine  
salt and pepper to taste

Combined all ingredients in a skillet and cook on top of the stove until the meat is thoroughly cooked. (For an alternative beef filling recipe see page 37.)

Assembling the Tacos:

On a freshly cooked tortilla spread about two spoonfuls of the meat filling. Roll the tortilla tightly around the meat. Repeat until you make all of the tacos you want. Then arrange the tacos on a plate, garnish with tomato sauce, grated cheese, lettuce and serve.

## MEXICAN - MAYAN COOK BOOK

\*\*\*\*\*

### SOPES

---

#### (Thick Bordered Tortillas)

Make a tortilla twice as thick as a normal tortilla. Cook on a comal on top of the stove turning them over until both sides are well done. While still hot make a border on the tortilla by pinching the edges of the tortilla with your fingers. Then make soft indentations all over the tortilla without tearing all the way through it.

Smear the tortilla with butter or lard, then cover it with green or red chili sauce and sprinkle shredded cheese on top. Alternatively you can use bits of bacon or shredded chicken.

### IZ UAH

---

#### (Camote Tortilla)

half dried corn  
lard or corn oil  
sugar or salt

Pick the grain corn just as it is drying down, and the shell of the grain is hard but the inner part is still moist. Shell the corn. Set in the sun to dry. Grind the corn and sift out the hulls, etc. Mix in the lard / corn oil and the salt or sugar. Grind again. Pat out the tortillas very thin, and cook on a dry griddle.

### BRAZO DE REINA

---

#### (“The Queen’s Arm”; a Steamed Corn Dough Roll with Pumpkin Seed Filling)

3 cups Masa  
3 tablespoons cooking oil  
1 pound chaya (or spinach)  
1 pound ground pumpkin seeds  
3 hard boiled eggs  
1 cup hot tomato sauce  
salt and black pepper to taste

Cook the chaya leaves in boiling water. When they are cooked drain in a colander, discard the water. After the chaya is cool mince well. Prepare the masa as shown in the recipe for Tortillas. Add the cooking oil to the masa and mix well. Then add the chaya and mix well. Make one big tortilla which is about ½ inch thick.

Chopped the eggs and add salt and pepper. Spread the chopped pumpkin seeds and chopped eggs on the middle of the tortilla and roll the tortilla into a log. Wrap the log with banana leaves and steam for 1 hour.

To serve cut the log cross-ways into ½ inch slices and top with the tomato sauce.

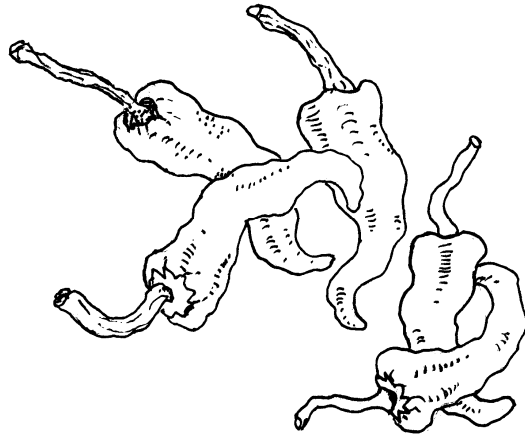

SAUCES

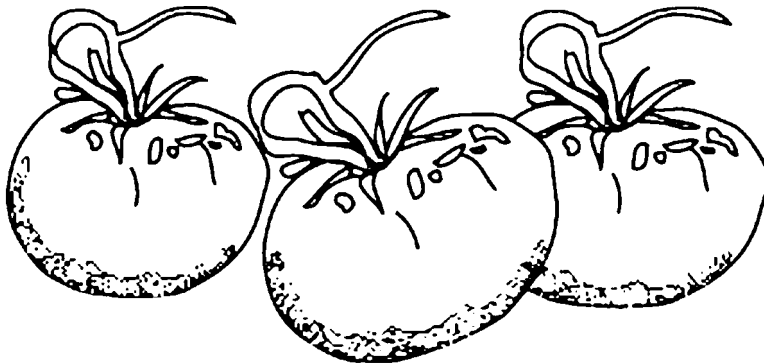



X-Tina preparing to make tortillas or **uah**

MEXICAN - MAYAN COOK BOOK

\*\*\*\*\*

PPAC YETEL IC

---

(Hot Tomato Sauce)

- 3 large fresh tomatoes, chopped
- 1 medium sized onion, chopped fine
- 1 sweet pepper, chopped fine
- 1 jalapeño chili pepper, split
- 3 tablespoons corn oil
- salt and black pepper to taste

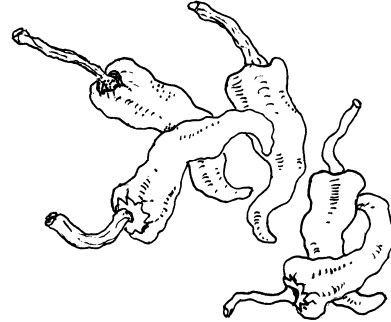

In a large saucepan combine all ingredients. Cook at medium-high heat stirring from time to time until tomatoes are soft.

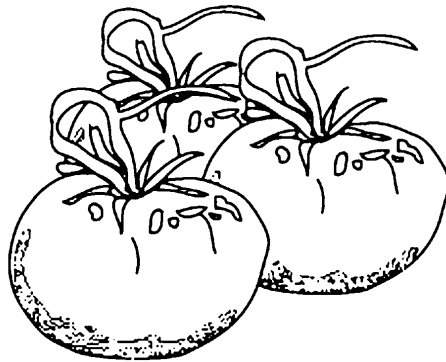

KELBIL PPAC YETEL IC

---

(Roasted Hot Tomato Sauce)

- 3 large roasted tomatoes
- 2 roasted jalapeño chili pepper
- 1 bunch onion tops, chopped fine
- 1 bunch coriander, chopped fine
- salt and black pepper to taste

In a lightly oil frying pan roast the tomatoes and chili peppers until the tomatoes are fully cooked. Discard any burnt skins.

In a **molcajete** grind the chilies with salt into a pulp. Then add the tomatoes and continue to mash them. Then add the finely chopped onion tops and coriander. Serve as a garnish with any kind of meat, also use as sauce for tacos.

## MEXICAN - MAYAN COOK BOOK

\*\*\*\*\*

### ZICIL PPAC

---

(Tomatoes with Pumpkin Seeds)

- 3 big red tomatoes
- 1 cup pumpkin seeds, ground
- 1 jalapeño chili pepper or other hot chili pepper
- 1 bunch coriander
- 3 onion tops
- salt to taste

Finely chop the chili, coriander, and onion tops. Roast the tomato on the skillet until the juice in the tomato begins to boil. Set aside to cool. Discard the skin and any burned parts and mash in the **molcajete**. Add the ground pumpkin seeds and salt and mix well. Serve with tortillas.

### SALSA VERDE

---

(Green Tomato Sauce)

- 3 large green tomatoes, or one pound of green tomatillos
- 1 bunch scallions, chopped
- 1 bunch coriander, chopped
- 3 jalapeño chili pepper
- salt and black pepper to taste

In a saucepan boil the jalapeño pepper and tomatoes for about 5 minutes. Then chop finely in a food processor. Combine all the other ingredients in the resulting sauce and serve on tacos or on any kind of meat.

## MEXICAN - MAYAN COOK BOOK

\*\*\*\*\*

### CUT IC

---

(Red Chili Sauce)

- 1 package of chili from New Mexico
- 3 cups water
- 1 medium onion, chopped
- 3 tablespoons cooking oil
- 1 teaspoon salt

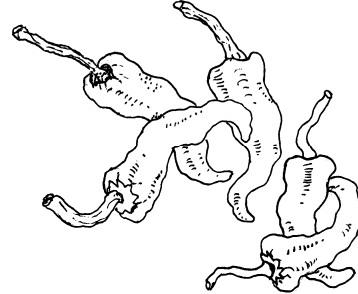

Discard the stems of the chilies. Open them and take out the seeds. Cut the chilies in pieces and dump them into the boiling water. Set aside and soak for two hours or overnight. Put in a blender, water and all, and blend for two minutes. Strain the resulting sauce with a fine strainer.

Sauté the onion in the oil with salt. Pour the chili sauce in and simmer for 15 to 20 minutes.

### GUACAMOLE

---

(Avocado Sauce)

- 1 ripe avocado
- 2 tablespoons lemon or lime juice
- 1 bunch coriander, chopped
- ½ jalapeño chili pepper, chopped
- 2 stalks scallions, chopped
- salt to taste

Cut the avocado in half and scoop out the meat. In a serving dish mash the meat coarsely with a fork while blending in the lemon juice. Add the rest of the ingredients and mix well. It is now ready to serve.

## MEXICAN - MAYAN COOK BOOK

\*\*\*\*\*

### KUXUB

---

(Achiote Coloring)

- ¼ cup achiote seeds
- ½ cup boiling water

Pour the boiling water on the achiote seeds. Let cool for 20 minutes. Put on disposable gloves and knead the seeds with your fingers. This dilutes the coloring in the water. Pour this in a strainer and discard the seeds.

This amount is good for one pound of meat. (chicken or pork or turkey).

### KUXUB YETEL PIMIENTA

---

(Peppered Achiote Coloring)

- ½ cup of achiote coloring
- 1 teaspoon black pepper corns
- 3 cloves of garlic
- 4 tablespoons of sour orange, lemon, or lime juice
- 1 teaspoon salt

In a **molcajete** or blender grind the black pepper, and the salt into a powder. Then add the garlic and continue to grind.

Add the sour orange / lemon / lime juice and the achiote coloring. Mix well. Use this for chicken or pork grind the black pepper and salt into a powder. Then add the garlic and continue to grind. Add the sour orange / lemon / lime juice and the achiote coloring. Mix well.

Use this for chicken or pork.



## MEXICAN - MAYAN COOK BOOK

\*\*\*\*\*

### ONZICIL DE REPOLLO

---

(Cabbage in Pumpkin Seed Sauce)

4 cups cabbage, chopped  
2 cups ground pumpkin seeds  
1 cups Masa Harina  
2 cups water  
1 tomato, chopped  
1 onion  
salt to taste

Sauté with three tablespoon oil the tomato and onion with the salt. Add the water. When this comes to a boil add cabbage. When the cabbage is cooked add the pumpkin seeds and set aside.

Serve with rice or noodles or tortillas.



### SALSA DE CHILE DE ARBOL

---

8 cups of dried red chile de arbol, (not ground)  
1 cup of vegetable cooking oil  
1 tablespoon salt.  
3 cloves of garlic (optional)

Clean the chilies with a dry rag. Sauté them in a big frying pan turning them over constantly for about 1 minute. Turn the heat off and keep stirring for another two minutes. Take the pan away from the stove and wait until the chilies are cool.

Put the oil in a blender and add some of the chilies. Repeat until all the chilies are added. Add the salt and blend to liquefy for 1 minute.

Store in de refrigerator or freezer.

MEXICAN - MAYAN COOK BOOK

\*\*\*\*\*



X-Mech in her store at the town plaza or **kiuc**



Mam X-Pil making her **uah** or tortillas

MEAT FILLINGS

and

MEAT DISHES





## MEXICAN - MAYAN COOK BOOK

\*\*\*\*\*

### TZAHBIL HUCHBIL BAK

---

(Beef Filling for Tacos)

- 2 pounds ground lean beef
- 1 medium sized onion, chopped fine
- 1 sweet green pepper, chopped fine
- 1 jalapeño chili pepper
- salt and black pepper to taste

In a large skillet mix all ingredients. Cook at high heat on top of the stove until meat is brown.

(Beef Filling for Enchiladas)

- 2 pounds lean beef cut in strips
- 6 cloves of garlic ground very fine
- The juice of two lemons
- salt and black pepper to taste

Marinate the meat with the lemon juice, the garlic and the salt and pepper. Cook in a saucepan with four tablespoons of oil until the meat is done.

Assemble the enchiladas as described in the recipe for Enchiladas.

Besides on enchiladas this dish is also good on white rice or tortillas.

### PICADILLO

---

- 1 pound lean hamburger
- ¼ cup olives
- ⅛ cup capers
- ½ cup raisins
- ½ tsp. salt
- ½ tsp. black pepper
- 1 medium onion, chopped fine
- 1 jalapeño chili pepper, chopped fine

In a large skillet combine all the ingredients and stirring constantly cook until done. Serve on tortilla shells.

## MEXICAN - MAYAN COOK BOOK

\*\*\*\*\*

### CHIMOL YETEL U BAKIL UACAX

---

(Chimole made with Beef)

- 1 pound ground lean beef
- 3 tablespoons black chili paste
- 1 tablespoon red achiote paste or ½ cup achiote coloring
- 1 medium onion, chopped
- 1 medium tomato, chopped
- 3 cloves of garlic
- salt and black pepper to taste

Mix the meat and all other ingredients in a large skillet. Fry until done.

Serve with any kind of tortilla.

### CHICKEN FAJITAS FOR TACOS OR ENCHILADAS

---

(Little Belts)

- 2 breast of chicken cut in thin strips
- the juice of one lemon
- 4 cloves garlic, ground finely
- salt and black pepper to taste

Mix all ingredients in a skillet. Fry in four tablespoons of oil until the meat start to get brown. Remove the meat and keep cooking to reduce the remaining broth.

When the broth is all evaporated and it starts to brown add ½ cup water to dilute the dry juice. Put the chicken back in and cook for another minute.

Serve immediately on top of white rice.

For tacos smear a tablespoon of guacamole on a tortilla. Place some of the fajitas in the center and top with lettuce and green sauce.

For enchiladas see the recipe for Enchiladas.

## MEXICAN - MAYAN COOK BOOK

\*\*\*\*\*

### ALBONDIGAS

---

(Meatballs)

- 2 pounds ground lean beef
- 1 pound ground pork (optional)
- 2 medium sized onion, chopped fine
- 2 tomatoes, chopped
- 1 sweet green pepper, chopped fine
- 3 cloves garlic, mashed
- 1 egg
- salt and black pepper to taste

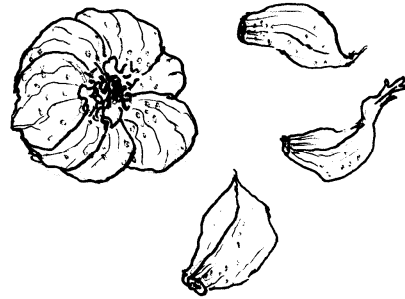

Sauté in a large saucepan with three tablespoons of oil the tomatoes, 1 onion, and the salt. Add 8 cups of water and bring to the boiling point. While this is coming to the boiling point mix in a large bowl the beef, pork, and all the rest of the ingredients. From the meat mixture make golf ball sized balls. Dump them into the boiling tomato sauce. Cook at medium heat for 20 to 30 minutes until done.

Eat with any kind of tortilla.



Don Crecencio preparing bits of meat for cracklings or **xix**

## MEXICAN - MAYAN COOK BOOK

\*\*\*\*\*

### CARNE CON VERDURAS

---

(Meat and Vegetable Soup)

- 2 pounds of beef for soup
- 2 pounds of beef bones
- 2 zucchini squash cut in big pieces
- 2 heads of kohlrabi peeled and cut in quarters
- 3 carrots cut in big pieces
- ¼ of a cabbage
- 2 sweet yellow peppers cut in big strips
- 1 big head of garlic
- salt and pepper to taste

Put the beef and the bones in a big pot. Cover the meat with water and add another four cups of water. When this is about to boil it forms a lot of foam. Take this out with a shallow big spoon and discard. Toast the head of garlic on the burner for about forty seconds. Wash the burn skins and add to the soup. Keep boiling the soup for about twenty minutes. Add all the rest of the ingredients. Keep on cooking until everything is cooked.

Serve with red radishes salad and white rice

### BISTEC

---

(Beefsteak)

(Either pork or beef can be used)

- 2 pounds of good soft beef sliced very thin
- 6 big cloves of garlic grounded very fine
- 1 tablespoon of freshly ground black pepper
- the juice of two lemons
- the juice of one orange
- salt to taste

Marinate the meat with all the ingredients. In a skillet sauté one piece of meat until is cooked. Set aside in a separate dish. Keep cooking the meat in the same skillet until all the meat is done.

Serve with a rice casserole and a salad.



## MEXICAN - MAYAN COOK BOOK

\*\*\*\*\*

### CHILI CON CARNE

---

- 4 pounds of lean ground beef
- 2 26 oz. can of Italian whole tomatoes
- 1 ½ cup of dry black beans
- 1 big onion cut in cubes
- 2 hot chili jalapeno chopped finely
- salt and pepper to taste

Remove any stones from the beans and cook on top of the stove until the beans are soft. Add salt and set aside. Add salt and pepper to the meat and cook it on top of the stove with the onions and the chili pepper until the meat is cooked and add this into the pot of beans. Chop the tomatoes coarsely and add to the beans. Cook for about twenty minutes.

Serve with grilled tortillas or french bread.

### PORK OR CHICKEN WITH TOMATILLOS

---

- 2 pounds of pork cut into big cubes
- 2 pounds of tomatillos peeled
- 4 very hot chili jalapenos
- 1 bunch of cilantro
- 6 big cloves of garlic
- 1 big onion
- salt and pepper to taste

In a pot combine the pork, onion, garlic and salt. Add four cups of water and cook on top of the stove. Wash chilies and the cilantro and put through a blender. Add this to the meat and keep on cooking until the meat is very soft.

Serve with tortillas or french bread.

Chicken may be used as an alternative meat.

## MEXICAN - MAYAN COOK BOOK

\*\*\*\*\*

### PIBIL KEKEN or COCHINITA PIBIL

---

(Barbequed Pork)

2 lbs. pork cut into chunks and washed well  
Juice of 3 limes  
2 tablespoon black pepper, freshly ground  
½ head of garlic  
½ cup achiote seeds  
3 pieces of a banana leaf, well washed  
Salt to taste

Rinse the achiote and soak them in hot water for 10 minutes. Put the pork in a big sauce pan.

Dilute the achiote and put them through a very fine strainer. Add this to the pork. Add enough water to cover the meat well. Add all of the rest of the ingredients and simmer for at least 2 hours.

### POLLO ADOBADO

---

(Chicken in Adobo sauce)

2 lbs. chicken cut into chunks and washed well  
Juice of 3 limes  
2 tablespoon black pepper, freshly ground  
½ head of garlic  
½ cup achiote seeds  
½ cup cooking oil  
3 pieces of a banana leaf, well washed  
Salt to taste

Rinse the achiote and soak them in hot water for 10 minutes. Put the chicken in a big sauce pan.

Dilute the achiote and put them through a very fine strainer. Add this to the chicken. Add enough water to cover the meat well. Add all of the rest of the ingredients and simmer for at least 2 hours.

## MEXICAN - MAYAN COOK BOOK

\*\*\*\*\*

### POC CHUC X-CAX (Broiled Chicken)

- 2 pounds chicken
- ½ cup achiote coloring
- 3 tablespoons vinegar
- 1 tablespoon of finely ground black pepper
- 3 tablespoon oil
- 4 cloves garlic

Grind all of the spices together. Add the vinegar and the achiote.

Cut the chicken into pieces, taking the skin off if you prefer. Wash in cold water and dry well with paper towels, then mix the pieces in the spice and vinegar solution. Charcoal-broil until done. Serve with rice or tortillas or potatoes.

---

### ESCABECHE DE POLLO

(Pickled Chicken)

- 4 pounds of chicken or turkey
- 3 cloves ground
- 4 cloves of allspice ground
- 1 tablespoon black pepper
- 5 tablespoons cooking oil
- 5 cloves garlic chopped
- 1 onion (chopped)
- the juice of 2½ lemon or lime
- the juice of 2 oranges
- salt to taste

Wash and cut the chicken into pieces. Peel and grind the garlic and mix it with all the other spices, oil, orange and lime juice. Smear the mixture on the chicken. Add onions. Place the pieces of chicken in a saucepan and add 4 cups of water. Set to boil at medium heat for 40 minutes or until the chicken is tender.

Place in a serving dish and serve with any kind of tortilla or rice or mashed potatoes. Serve with cebolla curtida.

## MEXICAN - MAYAN COOK BOOK

\*\*\*\*\*

### MOLE POBLANO

---

2 pounds turkey or chicken  
¼ cup sugar  
2 ounces of unsweetened chocolate  
1 banana peeled  
8 cloves of garlic peeled  
1 teaspoon cinnamon  
1 small onion  
1 small tomato  
1 jar of mole poblano  
salt and black pepper to taste

Wash and cut the meat in pieces. Put in a big pot and cover the meat with water. Add the garlic and salt and pepper. Cook on top of the stove until the meat is done. Put all the rest of the ingredients and broth from the meat in a blender. In a big saucepan heat about three tablespoon of cooking oil. Pour in the blended ingredients and cook on top of the stove. Stirring constantly for about ten minutes.

Pour on top of the cooked meat and cook in a very low heat for another ten minutes. If you are afraid of burning the food finish cooking in the oven for the last ten minutes until golden brown.

### MOLE POBLANO (with ground turkey meat)

---

1 pound of ground turkey  
1 medium onion [chopped ]  
1 big tomato [chopped]  
3 garlic cloves [chopped]  
salt and pepper to taste

Sauté in a large sauce pan until fully cooked.

1 can of mole poblano  
1 plantain banana  
4 cups of chicken or vegetable broth

Puree in a blender. Add this to the turkey mixture. Cook on top of the stove stirring constantly until the sauce thickens and boils for a couple of minutes.

Add more broth or water if sauce is too thick.

## MEXICAN - MAYAN COOK BOOK

\*\*\*\*\*

### POLLO ALCAPARRADO

---

(Caper Casserole)

- 5 pounds of chicken or turkey or pork
- 2 big potatoes peeled and cut in big pieces
- 8 cloves of garlic, minced fine
- 1 cup of Spanish olives (discard the vinegar)
- 12 cup of raisins
- 10 capers
- 1 big onion chopped
- 6 cups of water
- salt and pepper to taste

Cut the chicken in serving piece and take all the skin off. Wash in cold water and place in a big pot. Add all the ingredients except the potatoes and cook on top of the stove. 20 minutes before the meat is done add the potatoes and keep on cooking until the chicken is done. Serve with rice.

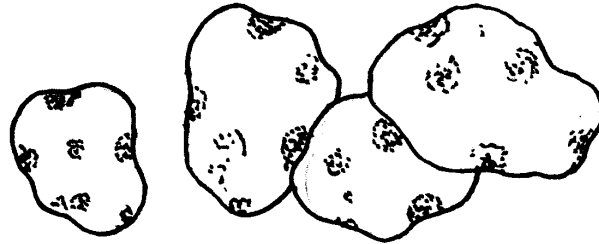

### EMPANIZADO DE POLLO

---

(Breaded Chicken)

- 2 chicken breast sliced very thin.
- 6 cloves of garlic crushed
- 1 teaspoon salt
- 1 teaspoon finely ground black pepper
- 2 table spoons of lemon or lime juice
- 2 cups of finely ground bread crumbs

Mix all the ingredients very well with the chicken except the breadcrumbs and let sit for at least ten minutes. Bread each one of the slices very firmly with the breadcrumbs. On a skillet fry each one of the slices with very little oil until golden brown. Serve with rice or mashed potatoes and a green salad.

## MEXICAN - MAYAN COOK BOOK

\*\*\*\*\*

### EMPANIZADO DE PESCADO

---

(Breaded Fish)

1 pound of tilapia fish filets  
1 egg white  
2 cups of corn flakes crumbs  
The juice of one lemon  
5 cloves of garlic crushed  
salt and black pepper to taste

In a flat bowl combine garlic, lemon juice and salt and pepper. Wash the fish filets with cold water and marinate in the lemon juice mixture.

Beat the egg white lightly and mix with the marinated fish. Take one piece at the time and coat them with corn flakes crumbs. Sauté in oil on slow heat.

### CHACBIL CAY

---

(Fish Soup)

1 pound cold fried fish  
1 medium onion, chopped fine  
1 medium tomato, chopped fine  
1 teaspoons freshly ground pepper  
2 cloves garlic  
4 cups water  
salt to taste

Cut the fish into pieces and put them in a saucepan with the water.

Sauté with three tablespoons of oil the tomato, onion, and garlic and add to the fish stock. Add the pepper and salt. Boil for about 20 minutes.

Serve on top of rice with a chili sauce

MEXICAN - MAYAN COOK BOOK

\*\*\*\*\*

CAMARONES FRITOS

---

(Fried Shrimp)

1 pound raw shrimp.  
1 big red chili guajillo crushed. (also called dried California chili)  
1 tablespoon ground black pepper.  
5 red hot dried chilies. (crushed)  
1 stick of butter.  
juice of two limes  
salt to taste

Wash the shrimp and cut each and one of them in half. In a big bowl mix shrimp, hot pepper, black pepper, chili guajillo and salt. Let rest for ten minutes or more. Fry in one stick of butter until done.

Turn off the heat and add lime juice all over. Serve with white rice or noodles.





BEANS,  
LENTILS  
and  
BEAN DISHES

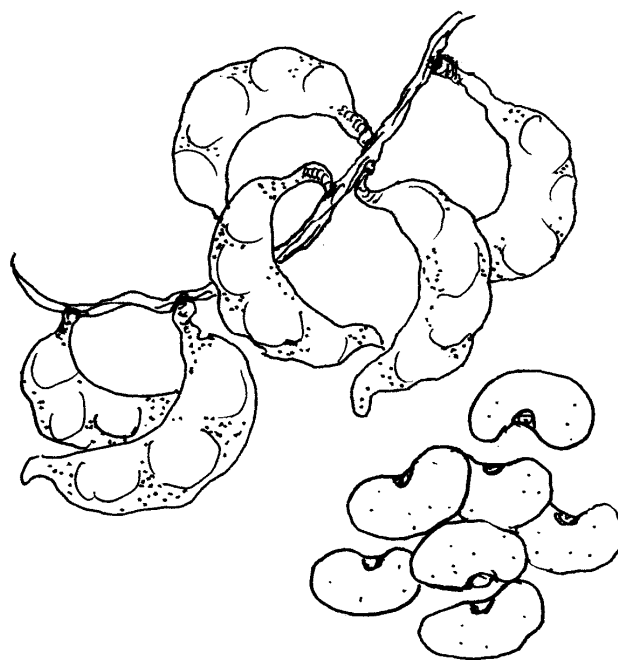



## MEXICAN - MAYAN COOK BOOK

\*\*\*\*\*

### BUUL

---

#### (Boiled Beans)

2 cups dry beans  
5 cups water  
1 onion, chopped  
3 tablespoons corn oil  
1 teaspoon salt

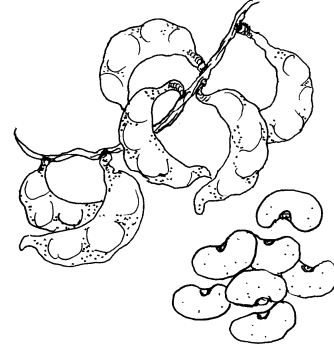

In a saucepan combine all the ingredients except salt. Bring it to a boil and turn down to medium heat. Cook for one hour and add salt. Continue to cook for another ½ hour or until beans are soft.

This dish is also called **Kabax** or **Kabax Buul**. The word **Kabax** means a food cooked very simply.

### BUUL YETEL KEKEN

---

#### (Frijol con Puerco)

Use the above recipe. Add a pound of pork ribs cut into approximate 1" cubes. Other ingredients such chimole and diced tomatoes may be added as well. Cook as stated above. Serve with Kelbil Ppac yetel Ic.

### TZAHBIL BUUL

---

#### (Refried Beans)

2 cups very well cooked beans  
1 large onion, chopped  
1 jalapeño chili pepper, chopped  
salt to taste

Mash and puree the beans. Sauté with four tablespoons of oil the onions, the jalapeño and salt. Pour in the bean puree. Simmer stirring constantly for about twenty minutes.

The beans will get richer and firmer if they get sautéed again.

## MEXICAN - MAYAN COOK BOOK

\*\*\*\*\*

### POTAJE DE FRIJOLES ROJOS

---

(Red Kidney Bean Soup)

- 2 cups dry beans (soaked overnight)
- 6 cups water
- 1 pound smoked ham
- 1 pound pork ribs
- 2 carrot, chopped
- 2 potatoes, diced into cubes
- 1 onion, chopped
- 2 tomato, chopped
- 4 long green chili peppers, whole
- 1 zucchini squash, chopped
- salt and black pepper to taste

Discard the water from the beans. In a saucepan combine the beans, water, ham, and pork. Bring to a boil and turn down to medium heat. Sauté with three tablespoons of oil the onion and tomato with the salt and pepper and add this to the boiling beans. Continue to cook for thirty minutes. Then add all of the remaining ingredients. Keep cooking until the beans and the potatoes are soft.

Serve with rice or tortillas or by itself.

---

### LENTIL SOUP

---

- 1 cup of dry lentils
- 2 Italian sausages cut in pieces
- 1 small onion cut in small pieces
- 1 tomato cut in pieces
- 1 big potato cut in pieces
- 2 carrots cut in pieces
- salt and pepper to taste

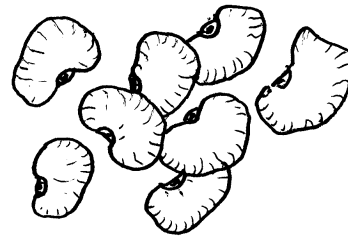

Remove any stones from the lentils and wash them. Put them in a pot with five cups of water. Fry the onion and tomato with oil and salt. Add to the lentils along with the carrots, the potatoes and the sausage. Cook on top of the stove for twenty minutes.

For a vegetarian dish omit the sausages.

## EGG DISHES

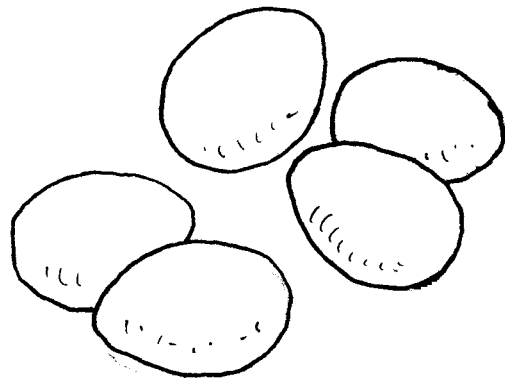



## MEXICAN - MAYAN COOK BOOK

\*\*\*\*\*

### TZAHBIL HE

---

(Fried Eggs)

1 egg  
1 pinch salt.

On a moderately hot skillet scramble the egg. Serve with tortillas, hot tomato sauce, boiled or refried beans, or any other compatible food.

### HUEVOS RANCHEROS

---

(Rancher's Eggs)

1 egg  
1 tortilla  
2 tablespoons refried beans  
2 tablespoons hot tomato sauce  
salt and black pepper to taste

In a skillet sauté the tortilla with any kind of cooking oil and place it on a plate and smear the beans on it. Fry the egg sunny-side up and place it on top of the beans. Now sauté the hot tomato sauce and pour that over the whole. Add salt and pepper. This is usually eaten for breakfast.

### HUEVOS A LA MEXICANA

(Also called PPIRIX HE)

---

(Mexican Eggs)

3 egg  
1 bunch of scallions, chopped  
1 tomato, chopped  
1 jalapeño chili pepper, chopped  
salt and black pepper to taste

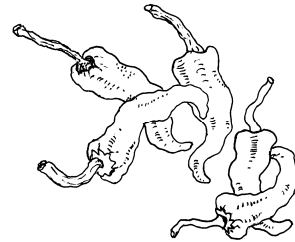

Beat the eggs. In a lightly oiled or butter skillet sauté quickly the scallions, tomato, and chili, adding the salt and pepper. Add the egg batter and keep frying until the eggs are cooked.

Serve with any kind of tortillas.

## MEXICAN - MAYAN COOK BOOK

\*\*\*\*\*

### HUEVOS MOTULEÑOS

---

(Eggs done in the Motul Style)

- 1 egg
- 1 tortilla
- 2 tablespoons refried beans
- 2 tablespoons hot tomato sauce
- 2 tablespoons cooked peas
- salt and black pepper to taste

In a skillet sauté the tortilla with any kind of cooking oil and place it on a plate and smear the beans on it. Fry the egg sunny-side up and place it on top of the beans. Now sauté the hot tomato sauce with the peas and pour that over the whole. Add salt and pepper.

This is usually eaten for breakfast.

### CHAY YETEL HE

---

(Chaya and Eggs)

- 1 cup minced chaya (or spinach)
- 1 onion
- 3 eggs
- salt and black pepper to taste

Cook the chaya leaves the same as spinach and put in a colander to drain the water. Mince the onion and sauté with three tablespoons of oil until translucent. Add the chaya, salt and pepper.

When the chaya gets very hot add the eggs. Stir gently until they are cooked.

Serve with tortillas and green sauce.



## MEXICAN - MAYAN COOK BOOK

\*\*\*\*\*

### ONZICIL HE

---

#### (Eggs in Pumpkin Seed Soup)

4 eggs  
2 cups ground pumpkin seeds  
10 green abaloob (native plums) (optional)  
1 tablespoon achiote paste  
1 medium tomato, chopped  
1 medium onion, chopped fine  
2 cups water  
salt to taste

Dilute the pumpkin seed meal and the achiote paste in the water and put through a strainer. In a big saucepan sauté the tomatoes and the onions and add salt. Add the pumpkin seed sauce. Add the abaloob and bring to a boil. When this mixture is boiling hard brake the eggs into the boiling mixture making sure that the eggs stay separate from each other. Lower the heat and let cook for about 15 minutes. Serve in a bowl and eat with tortillas.

### FRIDAY'S MEAL

Ever since the Mayans got converted to Catholicism they like to keep vigil on Fridays, which means in part that no meat can be eaten on this day. There are of course many vegetarian and fish dishes which can be used on this day of the week.

The people living near the ocean or the lagoons made by the barrier reefs on the Northern and Western sides of the Yucatecan peninsula often put other chores aside on Friday morning and go fishing. Towns further inland usually have a stand in the market which sells whole deep-fried fish. I remember that my children didn't want to eat the fish because they said that the eyes of the fish were staring at them.

The people who could not go fishing or could not afford to buy fish in the market made dishes with pumpkin seeds or other vegetables and grains. As you will notice throughout this book, there are many different dishes called **Onzicil**. **Onzicil He** is a good dish for Friday.

## MEXICAN - MAYAN COOK BOOK

\*\*\*\*\*

### CABALLERO POBRE

---

(Poor Knight)

Step 1:

#### SYRUP

6 cups water  
1 cup sugar  
1 cup raisins  
1 cinnamon stick

In a saucepan combine the sugar, raisins, and cinnamon in the water. Boil for ten minutes.

Step 2:

#### EGG BATTER

3 eggs  
1 dash of salt  
15 slices of French bread

Separate the egg yolks from the whites. Beat the whites until fluffy and firm. Add the egg yolks and salt. Gently mix into the egg whites. Smear about 1 tablespoon of the batter on each side of the slices of bread.

In a lightly oiled or buttered skillet sauté the slices of bread until golden-brown on both sides. Then soak the slices in the syrup for about two minutes.

To serve put a slice of the soaked bread on the plate and garnish it with raisins from the syrup.

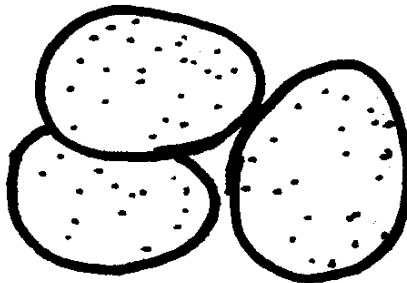

## MEXICAN - MAYAN COOK BOOK

\*\*\*\*\*

### CHILI RELLENO

---

(Stuffed Chilies)

4 green chili poblanos  
3 eggs  
1 package of Muenster cheese  
4 tomatoes  
1 small onion  
1 pint of heavy cream  
salt and pepper to taste

Puree the tomatoes and the onions. Add three tablespoons of oil and salt and pepper. Cook on top of the stove for about ten minutes. Pour in the heavy cream and set aside.

Toast the chilies on the burner until the skins of the chilies are black. Wrap them in a towel for about twenty minutes. Get rid of the skins by rubbing the chilies under running water. Get rid of the stems and the seeds. Pat them dry with paper towels.

Stuff them with slices of cheese. Coat them evenly with flour.

Fluff the egg whites until they form soft peaks. Add the yolks and salt and pepper. Dip the chilies in the egg batter and fry them one by one in oil on low heat. Keep turning them over until all the egg cover is cooked.

Serve with the tomatoes and tortillas.



## MEXICAN - MAYAN COOK BOOK

\*\*\*\*\*



Alejandra at the well in her house in Kom Cheen, Yucatan in the 1970's.

The growth of population in the nearby city of Mérida or **Ho** in the 1980's rendered the well water contaminated and unusable. There was an outbreak of cholera and immediately everyone began to buy bottled water. The Maya asked themselves, "What's next? Are we going to have buy bottled air as well?"

SALADS

and

FRESH VEGETABLE DISHES



## MEXICAN - MAYAN COOK BOOK

\*\*\*\*\*

### ENSALADA DE PEPINO

---

(Cucumber Salad)

- 2 medium cucumbers, chopped
- 1 bunch coriander leaves, chopped finely (optional)
- ½ jalapeño chili pepper, chopped finely
- 1 bunch scallions, chopped finely
- ¼ cup vinegar
- 1 tablespoon salt

Mix ingredients in a large bowl and chill in refrigerator for 20 minutes.

### CEBOLLA CURTIDA

---

(Pickled Onions)

- 2 red onions, chopped
- 3 tablespoons vinegar
- 1 jalapeño chili pepper, chopped
- 1 teaspoon salt



Boil the onions for 10 seconds. Pour out the water and add the vinegar, salt, and jalapeño chili pepper. Mix well.

### SALPICON DE RABANOS ROJOS

---

(Red Radish Salad)

- 1 bunch of red radishes, chopped
- 1 bunch of coriander, chopped
- 1 bunch of scallions, chopped
- 1 jalapeño chili pepper, chopped
- 3 tablespoon of vinegar
- salt to taste

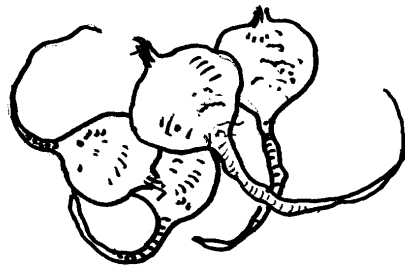

Combine all ingredients and mix well. Serve on any kind of taco filling.

## MEXICAN - MAYAN COOK BOOK

\*\*\*\*\*

### ENSALADA DE TOMATES

---

(Tomato Salad)

- 1 large tomato or 2 small canning tomatoes
- 1 bunch of coriander, chopped
- 1 bunch of scallions, chopped
- 1 jalapeño chili pepper, chopped
- 3 tablespoon of vinegar
- salt to taste

Combine all ingredients and mix well. Serve on any kind of taco filling.

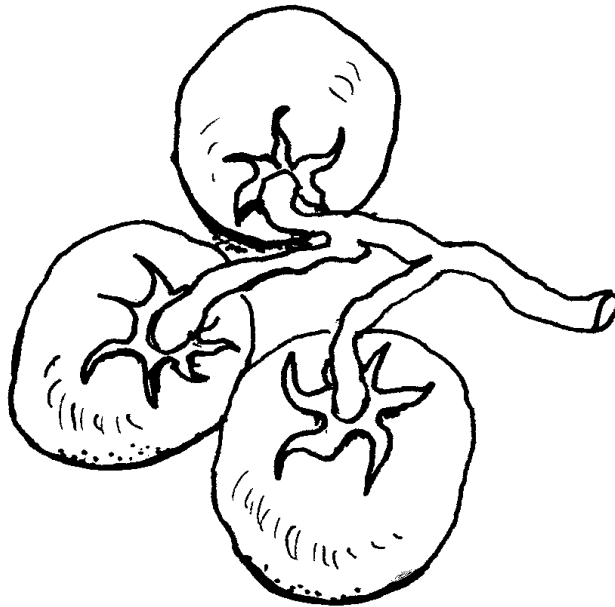



# RICE DISHES





## MEXICAN - MAYAN COOK BOOK

\*\*\*\*\*

### ARROZ A LA MEXICANA

---

(Mexican Rice)

- ½ cup oil
- 2 cups rice
- 4 cups water
- 2 tomatoes, chopped
- 1 jalapeño chili pepper, chopped
- 1 onion or 1 bunch scallions, chopped
- 2 cloves garlic, sliced

In a skillet sauté the rice in 3 tablespoons of oil at medium high heat until some them are golden brown. Drain the oil through a strainer. Sauté the garlic until golden brown. Add the tomatoes, jalapeño chili pepper, and onions. Combine the resulting mixture with the rice and add the water. Cook until done.

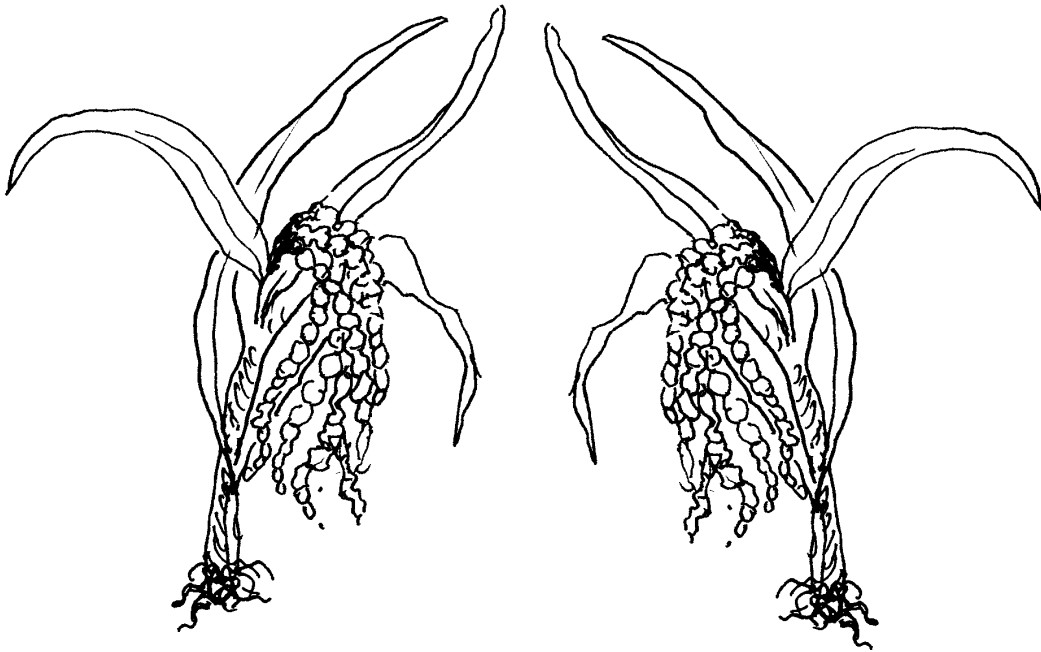



FOR MAYANS ONLY



## MEXICAN - MAYAN COOK BOOK

\*\*\*\*\*

### TU HE

---

#### (Rotten Eggs)

unhatched rotten eggs

Boil the eggs in water for 20 minutes. Peel. Discard any unappetizing parts. Eat with salt.

#### Yummy for My Tummy!

The Mayans will try to eat almost anything. If it doesn't kill them then they will eat it, even unhatched rotten eggs.

My grandmother would have liked the 12 eggs she placed under the roosting chicken to hatch, but if they didn't then she would boil them and give them to us children to eat. Some of the eggs looked like egg custard inside and even though they didn't taste like custard still it was good to eat. Others had a hard part at one of the ends. Grandmother said that that was the part where the chick was going to sit until it hatched. The other part of the egg was soft and green in color. It tasted a bit like wood ashes and it smelled like sulfur.

### TZAHBIL XUX

---

#### (Fried Wasp Larva)

- 1 wasp nest of the variety called **xux**
- 2 tablespoons red chili sauce

On a hot skillet place the layers of the wasp nest. When the larva have jumped out of their cells discard the nest layers. Stir the larva until golden brown. Pour them into the sauce. Ready to eat.

#### **PPIL A UICH!**

(CAUTION! OPEN YOUR EYES!)

You can not use just any wasp nest because some varieties of wasp larva are moderately to highly hallucinogenic or even very toxic. In Yucatan the only type of wasp larva I know of which can be eaten is a variety named **Xux**. This is a small black wasp with very narrow yellow bands on its tail. It has a mild sting. It builds its nests on the walls of wells and caves. There is always great excitement in the family when a **Xux** nest is found, because it means a nice munchy crunchy snack will soon follow.

## MEXICAN - MAYAN COOK BOOK

\*\*\*\*\*

### POCBIL HUH

---

(Roasted Iguana)

- 1 freshly killed iguana
- 1 cup achiote coloring
- red onion relish
- open fire

Cut off the head and feet of the Iguana and take out the guts. Rake out the hot coals to one side of the fire. Throw the iguana on the hot coals, turning over from time to time so that the skin does not get severely burnt. Roast for about 20 minutes, depending on the size of the iguana and the heat of the coals. When the skin starts to pop then it is easy to peel the skin off the iguana. The iguana is now done. Take out all the unwanted parts. Wash well with cold water. To add flavor baste the iguana with the achiote coloring and toast it on the open fire until golden brown. Then separate the meat from the bones and shred it **tzicbil**. Serve with red onion relish on tortillas.

### POCBIL HUH

---

(Alternative Method of Making Roasted Iguana)

- 1 freshly killed iguana
- 1 tablespoon achiote seeds
- 1 teaspoon black pepper corns
- 3 cloves of garlic
- 4 tablespoons of sour orange, lemon, or lime juice
- 1 teaspoon salt

Cut off the head and feet of the Iguana and take out the guts. Rake out the hot coals to one side of the fire. Throw the iguana on the hot coals, turning over from time to time so that the skin does not get severely burnt. Roast for about 5 minutes. When the skin starts to pop then it is easy to peel the skin off the iguana. Wash the iguana well inside and out with cold water. In a **molcajete** grind the achiote, the black pepper, and the salt into a powder. Then add the garlic and continue to grind. Add the sour orange / lemon / lime juice and mix to make the paste. Pour through a strainer. The iguana is then basted inside and out with the resulting liquid. Roast it on the open fire for about 15 more minutes until golden brown. Then separate the meat from the bones and shred it **tzicbil**. Serve with red onion relish on tortillas.



## MEXICAN - MAYAN COOK BOOK

\*\*\*\*\*

### POCBIL CHICH

---

(Roasted Bird)

several freshly killed birds  
1 tablespoon achiote seeds  
1 teaspoon black pepper corns  
3 cloves of garlic  
4 tablespoons of sour orange, lemon, or lime juice  
1 teaspoon salt

The birds most commonly used in this recipe are doves, partridges, pigeons, quails, and turtledoves. Needless to say, many more turtledoves are needed to make the same amount of food than are partridges.

Pull off the feathers of the birds. Wash the birds with ashes and sour orange juice to scour the skin. Wash with cold water to take off the ashes. Take out the guts. Wash the birds in cold water again.

In a **molcajete** grind the achiote, the black pepper, and the salt into a powder. Then add the garlic and continue to grind. Add the sour orange / lemon / lime juice and mix to make the paste. The birds are then basted inside and out with the resulting paste. Skewer the birds and place the skewers so that the birds are held just above the hot coals. Roast them on the open fire constantly turning them so that they do not get burned. Then separate the meat from the bones and shred it **tzicbil**. Serve with red onion relish on tortillas.

### MAM INÉZ

A common feature of southern Mexican Indian towns such as those in Yucatan is the system of township lands. This system predates the coming of the Spanish, and there are many land documents written in Mayan, Aztec, Zapotec, and other native languages which attest to the antiquity of this practice. These township lands can be used free of charge by anyone who lives in the town. People use them mainly to grow crops such as corn and vegetables, but they can be used for other agricultural purposes such as a place to locate beehives, a cattle watering and feeding place, or an orange grove.

Mam Inéz was a widow who lived in Ticul when I was young. She was quite stout, a common trait amongst the better feed Mayan women. She had such a plot of land in the township lands of Ticul and worked the plot, called **col** in Mayan, along with her four young sons. She was extremely poor and barely had enough money to buy things which the land did not provide, such as machetes, clothing, etc. Therefore she

## MEXICAN - MAYAN COOK BOOK

\*\*\*\*\*

usually had only corn to make **zacan** and vegetables, all from her own garden. In spite of their poverty Inéz and her children were quite happy because they rarely got sick and the land gave them most of what they needed.

She took her family every day out to work in the **col**, which was about a one hour walk away from town. About noontime the younger children would say that they were hungry. Inéz would stop her work in the **col** and tell her two older sons to go into the forest to find meat for lunch. Meanwhile she would roll up her sleeves with a gesture of readiness, roll a tobacco leaf into a cigar and put it in her mouth and light it, and start a fire to make big tortillas for lunch.

After a short while one of the older sons would come running back with an iguana. Inéz would kill the iguana with great dexterity and toss it under the **xamach** into to red hot coals. After five minutes she would take out the toasted animal and with a couple of pulls and tugs the whole iguana would be totally skinned. With a machete she then would cut off the head and feet and take out the guts. Then she would pat the meat with spices and throw the iguana back under the **xamach** to finish cooking.

After awhile the other son would come back with several of some kind of bird, such as quail or dove. With the same ease Inéz would take off the feathers, take out the guts, and smear the spices over the birds including inside the gut cavity. The birds were then skewered and set to roast on the fire.

While the meat would be cooking under the **xamach** Inéz would continue to make the big fat tortillas. The smell of the cooking food really made everybody hungry and as soon as everything was ready it was very quickly devoured. After eating the family had a short siesta in their cool hammocks. Then they would go back to work in the **col**.

## MEXICAN - MAYAN COOK BOOK

\*\*\*\*\*

### OXIL UAH

---

(Breadnut Tortillas)

1 bucket **ox** (breadnut) nuts.  
1 bucket water

Boil the breadnut nuts for 20 minutes. Let stand over-night. Take off the shells and skins leaving only the meat. Grind the meat to a fine mash. Mix with tortilla dough or wheat flour to improve the consistency. Make the tortillas as described in the recipe for regular tortillas.

### The **Ox** Tree

A Tree which Sustains Life in the Time of Drought

**Ox**, called the breadnut tree in English and ramon in Spanish, is classified as Brosium alicastrum Swartz. The **Ox** tree is used today mainly for its leaves to provide forage for cows and horses. The nuts of the **Ox** tree are also gathered and boiled to provide a grain substitute for pigs. In the memory of the older people today the nut of the **Ox** tree was used as a substitute for corn during the times of famine. The references to **Ox** in conjunction with the root **Cup** (Calopogonium coeruleum: jicama) seem to corroborate this usage as a food during a time of famine. In the Books of Chilam Balam, the Mayan sacred books, there is to be found in the prophecies the phrase **Oxil uah u uah, cupil uah u uah**. (“Breadnut tree tortillas is the tortilla (of the Katun), jicama root tortillas is its tortilla.”)

When the **Ox** trees in our back yard would drop lots of nuts then my grandmother and I would gather them up. While we were doing this she would talk about the times of famine which she would remember and say how these nuts help the people live through those terrible times. After we had gathered the nuts then she would put some in a pot and prepare the tortillas as shown above in the recipe. I suppose she made the tortillas in part to remember those days of famine and the people who were lost to her then.

The **Ox** tree appears to need a certain amount of human cultivation, at least in northwestern Yucatan, because it is rarely found outside of populated areas, and in fact it is a useful tree in finding abandoned population sites just because it seems to appear only in areas which are now or formerly population sites.

## MEXICAN - MAYAN COOK BOOK

\*\*\*\*\*

### KELBIL IC

---

(Chimole Paste)

½ pound dried red chili peppers

Make a little open fire outside the house. Toast the chilies on a griddle until all of them are black. Be sure to sit up-wind of the smoke, because the acid from the smoke is very strong and will cause respiratory problems.

After the chilies are scorched put them in a pot and pour cold water on them. Let them soak for ½ hour. Removed the chilies from the water and grind them on a metate (grind stone), adding the water from the pot as you grind to make a fine paste. Alternatively put the chilies and water in a blender and blend until a paste is formed. Then strain the resulting paste through a cheesecloth or a fine strainer.

### Party Time!

You can always tell when something special is going to happen in town. Everybody down-wind of the person who is preparing the Chimole paste is coughing like crazy and it doesn't take long to figure out who is preparing the paste. Chimole, especially when prepared with turkey as described in the following recipe, is the dish which is served on all important occasions, such as the town fiestas for the town's saint's days, anniversaries, funerals, etc. Because the turkey soup is prepared with the black chili paste, and because the head and feet are floating about in the black soup, the American students which came to stay with our neighbors in the village of Kom Cheen were very apprehensive about eating the soup, which came as a surprise to their Mayan hosts. However, some of the Americans found that they liked the soup after all, and got into the spirit of the occasion, in this case the town's saint's day.

## MEXICAN - MAYAN COOK BOOK

\*\*\*\*\*

### CHIMOL YETEL U BAKIL ULUM

---

(Chimole made with Turkey)

- 1 complete turkey, including head and feet
- 2 to 3 gallons water, depending on the size of the turkey
- 3 cups black chili paste
- 1 tablespoon achiote paste
- 2 medium onion, chopped
- 2 medium tomato, chopped
- 10 cloves of garlic
- salt and black pepper to taste

Dilute the black chili paste and achiote paste. Bring the water to a boil. Cut the turkey into serving sized pieces and put it and all of the rest of the ingredients in the water. Boil until the meat is properly cooked, about 3 hours.

Serve in soup bowls with tortillas.

### FIESTA!

The biggest occasion in every town is the town fiesta which is held in honor the town's Patron Saint. Many of the larger towns in fact have two different Patron Saints, and their days are spaced so that the fiestas occur about one half a year apart.

Each town is somewhat different in how a fiesta is carried out, but in general the most important days of the fiesta are Friday, with evening vespers and then at night the Mayan dance called the *Jarana*, Saturday, with a warm up bull fight (in which no bulls are killed!), vespers, and then at night a "western" style dance, and Sunday, with mass, the bull fight (in which the number of bulls needed for meat are killed), and a late afternoon western style dance. Each Church service is preceded by a meal for the participants of the service.

In smaller towns the job of putting on the fiesta is taken on by three of the various guilds, called *Gremio* in both Spanish and Mayan. Most of the adult citizens of the town belong to some guild, depending on their job or their interests. There are agricultural guilds, women's guilds, skilled laborer guilds, etc. Each of the chosen guilds is responsible for one day's festivities. It is the job of the president of each of the guilds which is putting on the fiesta to see that all of the necessary arrangements are made, for example getting the bands for the dances, hiring the bull fighters and getting the bulls for the bull fights, making sure that all the banners and the new cloths for the Patron Saint are prepared for the vespers and Sunday mass, and last but not least getting everything together for the meal which takes place before the

## MEXICAN - MAYAN COOK BOOK

\*\*\*\*\*



vespers and the Sunday mass. It is a very great honor to be the president of the guild which is putting on the fiesta, but it is also a very great expense for him or her. While the president will solicit donations from other people, in the end it is his or her responsibility to cover all the costs which are incurred. Of course there are entry fees to the dances and the bullfights, but these fees never cover the expenses.

The pre-Church service meal almost always consists of three things: tortillas, Chimole made with turkey, and the rice drink called Horchata. Prior to the feast day a large area is cleaned around the house. Pavilions are set up to shade the guests, and the firewood and cooking utensils are brought together. Also sometime during the



week the chili peppers are roasted to make the Chimole paste. The afternoon before the feast day the first step in getting the corn ready for making tortillas is carried out. Early the next morning volunteers come to the house. Some set to work killing and preparing the turkeys for the Chimole and other are washing and preparing the corn to take to the mill so that the tortillas can be made.

## MEXICAN - MAYAN COOK BOOK

\*\*\*\*\*



At the appointed hour, usually 4 p.m. on Friday and 10 a.m. on Saturday and Sunday, people gather at the Church bringing with them the new banners they have made. There the older banners in the Church are handed out to people willing to carry them, and then there is a procession accompanied by a marching band and the firing of rockets which goes from the Church to the president's house. Upon entering the house a little ceremony

takes place in which the president receives prayers from a chanter with much incense. The chanter then leads the president and those bearing the new banners into the house and more prayers are said in front of the table which has the household Saints on it. At this time the banners are also blessed.



While the prayers and blessings are taking place volunteers are helping serve the food to all present. The band is seated in a special area and play from time to time as the mood strikes them, and the boys and men who are in charge of the rockets light them off between bites of tacos of Chimole and sips of rum. When the president is finished with the prayers and blessings he or she comes out to join with the volunteers in serving the food to the guests.

## MEXICAN - MAYAN COOK BOOK

\*\*\*\*\*



When everybody has finished eating then the procession is formed again, with the president in front, usually carrying new clothes for one of the Saints in the Church, and the band bringing up the rear. Rockets again are fired off and the procession marches to the Church. The procession passes by the front door of the Church once and goes around it in a counter - clockwise direction and then enters the Church.

After the service the people go home and prepare themselves for the next occasion, the Jarana if it is Friday or the bullfight if it is Saturday or Sunday.





## MEXICAN - MAYAN COOK BOOK

\*\*\*\*\*

### U HANAL ALANCIL

(Foods Given to the Mother of a New Born Baby)

When a baby is born in a Mayan home there are several practices which are special to the Maya of Yucatan. As the time for delivery approaches one end of the house is sealed off from the rest of the house by hanging sheets across it. That is so the **Kakaz Ikoob**, the evil winds or spirits, can not enter the area where the mother and child are. Also it gave the mother some privacy from all of the other members of the family who sleep in the house.

This event, that is that of a child being born, happened without fail at my house every two years for 22 years. Of the 12 children born to my Mother 10 survived, an unusual number in those days. That is, usually half the children born would die from some childhood disease. Anyway, the sheets sealed my Mother and my Grandmother from our view, but as I grew up I started to notice the noises and the cries that came from the other side of the sheets. Most of the time I was terrified because my Grandmother used to tell me that people died from this sort of thing.

While there is a particular term, **Alancil**, which is applied to child bearing, the Mayans today usually refer to a pregnant lady as being **Kohaán**, "sick". When I asked my Grandmother if my mother was ever going to be cured of this sickness she replied that nobody could cure her and that it was the will of God that people who got married had to have babies. While I listened to all the cries of pain in the middle of the night I used to swear that I would never get married so as to keep this terrible sickness away from me.

Of course the babies always arrived just before dawn. Then my Grandmother who served as the midwife when each of us was born would clean both my mother and the baby. She would put the herb **alucema** on the baby's belly button to dry it and put a bandage over it to keep the flies and dirt off it. Afterwards she would get me out of my hammock so I could help her prepare breakfast for my mother.

My mother had to stay behind these sheets in confinement for nine days. During the course of this time she was concealed from the **Kakaz Ikoob**, the evil spirits or bad winds, and from people who were sick and especially from people who were drunk because drunk people carried all of the **Kakaz Ikoob** with them and could make the mother or the baby sick. During the course of these nine days after the birth of the baby my Mother was given special foods cooked in special ways so that she could regain her strength and for spiritual reasons.

## MEXICAN - MAYAN COOK BOOK

\*\*\*\*\*

### **CHUCUA YETEL HE** (Hot Chocolate with Egg)

For breakfast my Grandmother would make a hot chocolate drink with egg. This chocolate drink is prepared very much like the normal chocolate drink described in the Section on drinks, except that a fresh egg is dropped into it.

---

#### CHUCUA YETEL HE

---

- 1 cake of chocolate
- 2 cups of boiling water
- 2 tablespoon sugar
- 1 fresh egg

Break the chocolate cake into the batidor or blender and pour in the boiling water. Blend vigorously for about 10 seconds. Add the egg and blend for another 10 seconds. Then add the sugar and stir. Serve with sweet rolls or toasted tortillas.

After my Grandmother prepared the food she put it in a bucket and covered it carefully with a clean cloth so that no dust or flies would fall in it while she carried it from the kitchen to were my Mother was laying down.

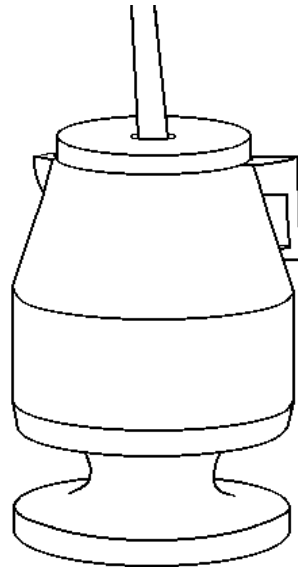

## MEXICAN - MAYAN COOK BOOK

\*\*\*\*\*

### CHACBIL X-CAX

(Boiled Chicken)

(also called **X-Kabax X-Cax** "Plain Cooked Chicken")

On the first day after the birth my Mother was given Hen Soup for Lunch. The hen has to be fairly old and healthy and also one which is laying eggs every day.

---

### CHACBIL X-CAX

(Boiled Chicken)

- 1 older egg-laying chicken
- 1 head of garlic, toasted
- 1 big onion, cut into quarters
- 1 bunch of mint leaves
- salt and black pepper to taste

Wash the chicken in cold water and cut into pieces. Place the pieces of chicken in a saucepan and add 1 gallon of water. Add all of the ingredients. Set to boil at medium heat for 1 hour or until the chicken is tender.

Place in a serving dish and serve with **Pimpim Uah** and **Salpicon de Rabanos Rojos**.

For dinner left over Hen Soup was served with Hot Chocolate with Egg.

On the second day breakfast again consisted of Hot Chocolate with Egg and toasted tortillas or sweet rolls. Then for lunch my Grandmother prepared Roasted Eggs.



## MEXICAN - MAYAN COOK BOOK

\*\*\*\*\*

### **POCBIL HE** (Roasted Eggs)

On the second day my Mother was given a pair of fertilized eggs cooked in hot ashes. The Mayans believe that this has medicinal properties which help the mother convalesce. My Grandmother said that eating eggs cooked in this way will make the mother of the new born baby invulnerable to the **Kakaz Ikoob**.

---

### POCBIL HE

(Roasted Eggs)

fresh eggs  
open fire  
salt and black pepper to taste  
tortillas

Place the eggs in water to moisten the shells. Make a hole in the hot ashes. Bury the eggs in the ashes. Leave the eggs in until one of the eggs explodes, or at most 20 minutes. Dig them out and let them cool. Then peel and discard the eggshell and any dirty part. Then puree and add salt and pepper. Eat with tortillas.

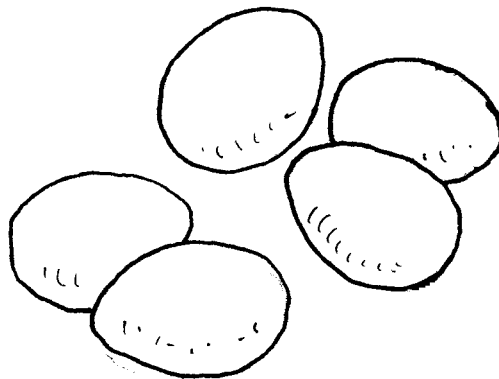

## MEXICAN - MAYAN COOK BOOK

\*\*\*\*\*

### PIB

---

(Barbecue)

4 tamale pies  
2 brazos de reina  
2 large ppichil ichil cho  
2 dozen small tamales

Make the **Pib** (fire pit) as described on page 3 under the heading **Pibil**. Prepare the foods listed here according to the recipes given in the Section on Tortillas and Things Made From Basic Corn Dough. After the pib is ready to receive the food place in the above items filling in all the areas. Cook for about 1 hour.

### Finados

**U Hanal Pixanoob** (the feast of the souls): The fiesta called Finados, or properly Día de los Finados, also known as Día de Todos los Santos and Día de los Muertos, takes place from the 31<sup>st</sup> of October and lasts for eight days. The first day of Finados is dedicated to infant and young children's souls and the last day to older people's souls. On the first and last days of these feast days food offerings are prepared for the souls of dead relatives. In particular various tamale-like breads are prepared in the **Pib**. The above list is a typical assortment, but there is wide variety of tortillas and pies which can be placed in the **Pib**.

On the first day of Finados Grandmother and Mother would get up before dawn and start preparing the food which would be offered to the souls later in the day. First of course they had to kill and pluck the chicken or turkey. While the women were preparing the food the men would be digging a big hole in the ground to serve as an oven, the **Pib**. Since the first day of Finados is dedicated to the children's souls there is chicken vegetable soup and soft tamales.

For breakfast Grandmother put colored candles which can only be found on this day on the table along with **Chucua** (hot chocolate), **Chuhuc Uah** (sweet rolls), and water. Then she would put flowers on both sides of the pathway leading to the front door of the house and continued this pathway into the house to the table. This was done to show the souls that they are welcomed and to guide them to the table were their meal would be waiting for them. When everything was ready on the table Grandmother would light the candles one by one as she would call out the names of the dead children. She would always put extra food and candles on the table for those souls who did not have living relatives. She would say to me, "We have to do this so

## MEXICAN - MAYAN COOK BOOK

\*\*\*\*\*

they can have a place to rest. Otherwise they would be floating in space the whole time.”

Then at about 4 in the afternoon the table would be filled with bowls containing chicken vegetable soup, tamales, fruits, and all kinds of colored candies. Then a chanter, who was paid with food, came to chant a welcome to the souls. She would in the course of the chant call out the names of the souls. The neighbors and friends would be invited to listen and participate in the chanting. After the ceremony the food from the table which are usually the best cuts of meat would be distributed among the participants. Then the guests would go home and the family would sit down to eat and have a good time.

A week later it is the turn for the older people’s souls. It is done in much the same way as it was done for the children’s souls, except that more grown-up food and drinks are put on the table, for example spicy hot tamales, beer, and liquor. Also, the candles are not colored but are big and fat.

## MEXICAN - MAYAN COOK BOOK

\*\*\*\*\*

### PIBIL KEKEN

---

(Barbecued Pig)

- 1 very young pig
- ½ cup achiote seeds
- 10 cloves of garlic
- ¼ cup ground black pepper
- ¼ cup salt
- 5 green oranges

Before dawn, get the pig and kill it. Clean the hairs off the skin by pouring boiling water on it and then scraping it with a knife. Open the pig and discard the unwanted parts. The Mayans save the intestines and the brains, but they throw away the anus, the genitals, the bladder, and the bones.

On a grinding stone grind to a paste the achiote, the garlic, the black pepper, and the salt. Dilute the paste in the juice of the sour oranges and strain it through cheese cloth.

Brush the sauce on the meat. Cook the meat in a **Pib** (fire pit) for three hours. When the meat is cool enough to handle pull it apart into pieces which are of the appropriate size for putting into tacos.

### PIBIL NAL

---

(Barbecued Corn)

3 dozen fresh corn

Make a **pib** as described in the section on cooking methods. Cook for one hour.

**Pibil Nal** is a special treat and is normally available only during the late summer months when the corn has ripened but not yet started to dry out. While most corn farmers grow corn particularly for the grain some will harvest a portion of their corn to sell as **pibil nal**. Normally the corn used for **pibil nal** is just grain corn, and so is not sweet like the sweet corns grown here in North America.

## MEXICAN - MAYAN COOK BOOK

\*\*\*\*\*

### PIBIL CEH

---

(Barbecued Venison)

The following recipes are made from barbecued venison, but any kind of barbecued or roasted meat will do. Typically the only way the various game animals are available to the general populace is as already cooked meat. This meat is sold by special vendors in the larger markets, such as the one in Mérida. In the smaller towns the hunters will sometimes sell the meat directly to their neighbors. These game animals include **ceh** (deer), **citam** (peccary), and **haleb** (agouti, a type of local woodchuck classified as *Dasyprocta punctata yucatanana*). They come to the market precooked in a **pib** (barbecue) because the hunters who catch these animals are usually quite some distance in the forest and it would take a day or two in order for them to get the meat to market. Therefore the meat is barbecued where the animal was killed as a method of preserving the meat.

### TZICBIL CEH

---

(Shredded Venison)

- 1 pound cooked venison
- 1 bunch red radishes, chopped fine
- 1 bunch coriander leaves, chopped fine
- 1 jalapeño chili, chopped fine
- 3 scallions tops, chopped fine
- 1 sour orange or ½ lemon
- salt and black pepper to taste

Shred the venison by pulling it apart with your fingers. Then in a large bowl mix all of the ingredients with the meat. Squeeze on the juice from the sour orange or lemon.

Serve with tortillas.



## MEXICAN - MAYAN COOK BOOK

\*\*\*\*\*

### CHILAQUIL DE VENADO

---

(Venison in Chili Soup)

2 pounds cooked venison with bones  
2 long yellow hot chili peppers  
1 onion  
1 bunch coriander  
1 teaspoon freshly ground black pepper  
1 roasted garlic  
7 cups water  
salt and black pepper to taste

Roast the garlic on a frying pan. Place the venison in a saucepan with the water, roasted garlic, salt, and pepper, and bring to a boil. Sauté the chili peppers and onion and add to the meat. Continue to boil for 20 minutes. Add the coriander and boil for another 20 minutes.

Serve in soup bowls with rice or tortillas and green chili sauce.

### ONZICIL CEH

---

(Venison in Pumpkin Seed Sauce)

1 pound cooked venison  
3 cups pumpkin seeds, finely ground  
½ cup Masa Harina  
1 medium ripe tomato  
1 medium onion  
2 cloves garlic  
salt to taste

Soak the pumpkin seeds in 6 cups of water. Pour the sauce through a strainer to get rid of the hulls. Place the meat, pumpkin seed sauce, and salt in a saucepan and boil at medium heat. Sauté the onion, tomato, and garlic and add to the saucepan. Cook for about 20 minutes. Add the Masa Harina to thicken the **Onzicil** sauce. Cook for another 5 minutes.

Serve in soup bowls with tortillas and green chili sauce.

## MEXICAN - MAYAN COOK BOOK

\*\*\*\*\*

### U TUNICHIL CEH (The Deer Stone or Bezoar)

My Grandmother had four children. The oldest was my uncle Tio Ladis. He was a nice man who supported his family by being a tinker. Tio Ladis also tended a parcel of land in the township lands of Ticul. On his way to and from his **col** (garden) he would keep his eyes open for game animals and was able to shoot something from time to time.

When my uncle was a young man there were many more game animals in the forest than there are today, because of course the number of people was much less then. Every morning at about 4 a.m. Tio Ladis would go to his **col** and work there until noon. When he returned home it was very exciting for the children because he would bring vegetables, corn, and some bird or animal for supper. I remember one time when he brought a litter of baby rabbits and a bag of quail eggs. I always liked going to visit my uncle's home because there were always many different animals to look at, such as parrots, various varieties of song birds and doves, armadillos, rabbits, turtles, and other such animals which are easy to tame.

One day Tio Ladis stayed in the **col** with his son Ramon for the whole day and part of the night. We were all very worried that something terrible might have happened to them. Then around mid-night they returned bringing with them a deer all cooked and ready to eat.

The next day we were all invited over to eat at Tio Ladis's house. While we were eating the venison he told us a story of about the deer's magical stone. He said that when he was younger he could kill a deer whenever he needed meat. The reason he could do this was because one day when he killed a deer he found the magical stone in its stomach. If a person finds one of these stones and no one else sees it then whenever the hunter sees any kind of animal it will change itself into a deer and he can kill it. The magic last for the hunter for a full year. At the end of the year the hunter must return the magical stone to **U Yumil Ceh**, the Lord of the Deer, or face death by being cornered in the forest by the stags lead by **U Yumil Ceh** and being killed by them.

Unfortunately, Tio Ladis did not get to keep the magical stone for a full year. One day his wife, Tia Nas, saw the stone while she was packing a lunch in Tio Ladis's hunting bag. The stone lost its charm and he immediately returned it to the forest to give it back to **U Yumil Ceh**.

## MEXICAN - MAYAN COOK BOOK

\*\*\*\*\*

### SOPA DE YUCCA

---

(Yucca Soup)

- 1 medium chicken cut in pieces
- 2 red potatoes peeled and diced
- 2 white potatoes peeled and diced
- 3 cups of yucca cut in cubes as big as prunes
- 1 big celery root or 3 kohlrabis cut as big as prunes
- 2 sweet potatoes
- 2 big onions
- 8 cloves of garlic
- 1 small package of mixed frozen vegetables
- 1 small package of frozen corn
- 1 teaspoon of black pepper
- 1 cup of cilantro leaves

Put the onion and the garlic in a food processor and mince very fine. Wash the chicken and cut in big pieces. Combine chicken, the potatoes, the yucca, the celery root and the sweet potatoes and add enough water to cover all this. If you like a thinner soup add more water.

Bring to a boil and reduce the heat so that it does not boil too hard. Add salt and pepper to taste. Keep on cooking until the meat and the vegetables are tender.

Ten minutes before the soup is done add the thawed frozen vegetables. Add cilantro if desired.



PANCAKES  
and  
PAN FRIED DISHES



## MEXICAN - MAYAN COOK BOOK

\*\*\*\*\*

### SWEET CORN PANCAKES

---

- 5 ears of sweet corn
- 2 eggs
- 2 tablespoons sugar
- 1 teaspoon salt
- ½ cup milk
- ½ cup flour

Remove kernels from the corn. Put in a blender with the milk. Strain with a fine strainer. Add eggs, salt, and sugar. Then add enough flour until the mixture has the right consistency for pancakes. Cook the pancakes on a lightly greased or oiled griddle.

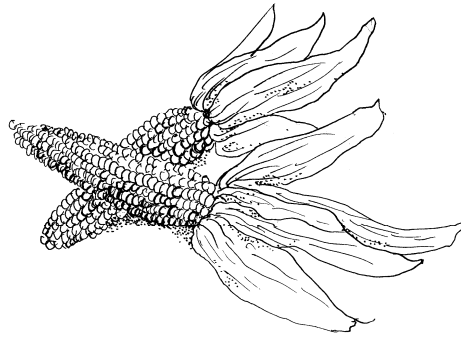

### SQUASH PANCAKES

---

- 2 cups whole wheat flour
- ½ cup sugar
- 1 tablespoon baking powder
- ½ teaspoon salt
- 2 cups milk
- 4 eggs
- 2 cups cooked squash
- ⅓ stick butter

Mix the dry ingredients. Then mix in the eggs and while stirring add the milk until the batter is the right consistency. Then mix in the squash and butter.

Cook on a lightly butter skillet. Serve with syrup or honey.

## MEXICAN - MAYAN COOK BOOK

\*\*\*\*\*

### TORTILLAS DE CALABAZA

---

#### Zucchini Squash Pancakes)

1 cup of very fine strips of zucchini squash.  
2 eggs  
1 cup of flour  
¾ cup of milk  
salt and pepper to taste

In a big bowl mix all the ingredients. Cook like pancakes until golden brown.  
Garnish with red onion salpicon and serve.

### TORTAS DE BERENJENA

---

#### (Eggplant Pancakes)

2 cups flour  
½ teaspoon salt  
½ cup milk  
2 eggs  
2 cups Eggplant, diced fine

Mix the dry ingredients. Then mix in the eggs and while stirring add the milk until the batter is the right consistency. Then mix in the eggplant.

Cook on a lightly buttered skillet.



## MEXICAN - MAYAN COOK BOOK

\*\*\*\*\*

---

### TORREJAS

---

(Banana Fritters)

- 2 bananas
- 1 cup of flour
- 1 teaspoon baking power
- 2 eggs
- ½ teaspoon salt

Puree the bananas very well. Add eggs and mix well. Mix the dry ingredients and combine them with the banana and egg puree mixing until smooth.

Deep-fry spoonfuls of the batter at low heat until brown on both sides.

---

### PLATANOS FRITOS

---

(Fried Bananas)

- 3 bananas
- salt

Slice the bananas onto a skillet. Brown both sides at medium heat in 2 tablespoons of oil. Sprinkle with salt.

Goes well with beans and any kind of meat.

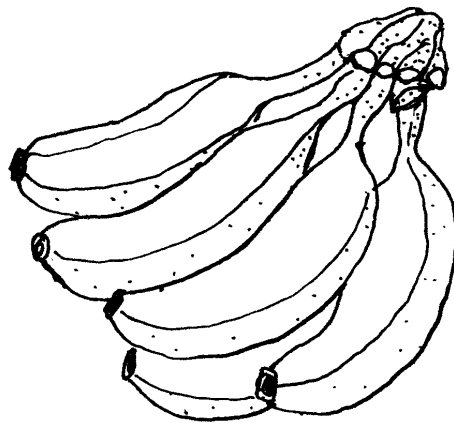



## PASTRIES



## MEXICAN - MAYAN COOK BOOK

\*\*\*\*\*

### PASTELITOS DE CALABAZA

---

(Squash Pastry)

These pastelitos consist of a filling made with squash and a shell made with pastry dough.

#### 1) The Filling:

- 1 cup baked squash
- ½ cup sugar
- 2 eggs
- ½ teaspoon salt
- 1 teaspoon cinnamon

Mix all the ingredients and set aside.

#### 2) The Pastry Shells:

- 2 cups flour
- 1 tablespoon baking powder
- 1 teaspoon salt
- 3 tablespoons milk
- 1 stick butter

Mix the dry ingredients. Chop the butter into it. Then add the milk and mix until the dough is the right consistency. Form golf ball sized balls from the dough and flatten them into thick tortillas.

#### 3) Making the Pastelitos:

Put one teaspoon of the squash filling into the middle of the pastry tortilla and fold the tortilla into a turnover, crimping the edges well. Bake the pastelitos at medium heat for ½ hour. Before serving garnish with confectionery sugar.

## MEXICAN - MAYAN COOK BOOK

\*\*\*\*\*

### PASTELITOS DE COCO

---

(Coconut Pastry)

These pastelitos consist of a filling made with coconut and a shell made with pastry dough.

#### 1) The Filling:

- 1 coconut, peeled and ground fine
- 1 ½ cup sugar
- ½ teaspoon salt
- 1 teaspoon cinnamon
- 1 cup water

In a saucepan mix all the ingredients and cook for 20 minutes. Set aside to cool.

#### 2) The Pastry Shells:

- 2 cups flour
- 1 tablespoon baking powder
- 1 teaspoon salt
- 3 tablespoons milk
- 1 stick butter

Mix the dry ingredients. Chop the butter into it. Then add the milk and mix until the dough is the right consistency. Form golf ball sized balls from the dough and flatten them into thick tortillas.

#### 3) Making the Pastelitos:

Put one teaspoon of the coconut filling into the middle of the pastry tortilla and fold the tortilla into a turnover, crimping the edges well. Bake the pastelitos at medium heat for ½ hour. Before serving garnish with confectionery sugar.

DESSERTS

and

SNACKS





## MEXICAN - MAYAN COOK BOOK

\*\*\*\*\*

### U TUCH JESUS

---

(Jesus' Belly Buttons: A Fried Dough Pastry)

- 2 cups flour
- ¾ cup milk
- 2 eggs
- 1 teaspoon baking powder
- 1 teaspoon salt

In a bowl mix the dry ingredients. In a separate bowl beat the eggs for a few seconds. Add the eggs and milk to the dry ingredients. Mix thoroughly until smooth. Deep-fry tablespoon sized balls of the batter in a skillet with about 1 inch of corn oil at medium high heat. Turn them over about every 20 seconds and cook them until golden-brown.

Serve with confectionery sugar, syrup or honey.

Navidad  
(Christmas)

Christmas is not a particularly important day amongst the Maya, or at least it was not important until recently when the influence of American television programs began to make an impact on Mayan society. The major event of Christmas, which takes place on Christmas Eve, is that people go from house to house to see where the table on which the saints and the cross is set up has been made into the crèche. In some houses a special effort is made to rearrange the saints to make a crèche. In these houses the family will have prepared **U Tuch Jesus** (called buñuelos in Spanish) to be given out to all of the visitors. After the visitors have admired the crèche and eaten their **Tuch Jesus** they will continue on the next house which has a crèche. My Grandmother always told us when we got hungry during the day before Christmas to be careful not to eat too much, because if we did we would never be able to eat **U Tuch Jesus** at every house when we went out that night, and the hostess might feel offended if we didn't eat her food.

## MEXICAN - MAYAN COOK BOOK

\*\*\*\*\*

### QUESO NAPOLITANO

---

(Neapolitan Cheese)

- 1 can condensed milk
- 4 eggs
- 1 teaspoon vanilla
- ½ teaspoon salt
- ½ cup sugar
- 4 tablespoons water

In a saucepan sauté the sugar with 4 tablespoons of water until golden brown. Pour this into a double boiler. Whip the eggs, milk, salt, and vanilla and pour this into the double boiler pan over the sugar. Cook for about an hour or until done. Test by inserting a knife into the cheese. It should come out cleanly.

### FLAN NAPOLITANO

---

(Neapolitan Custard)

- 1 Philadelphia cream cheese
- 1 can of sweet condensed milk
- 1 can evaporated milk
- 1 teaspoon vanilla
- 4 eggs
- ½ cup sugar
- 4 tablespoons water

In a saucepan sauté the sugar with 4 tablespoons of water until golden brown. Pour this into a double boiler.

Combine the remaining ingredients in a blender. Pour into the double boiler. Cook on top of the stove until the tip of a knife comes clean.

## MEXICAN - MAYAN COOK BOOK

\*\*\*\*\*

### FLAN

---

(Caramel Custard)

#### Ingredients

- 4 large eggs
- 2 whites only from large eggs
- $\frac{3}{4}$  cup of sugar
- 2 cups of milk
- 1 tablespoon vanilla

#### For the caramel

- $\frac{1}{2}$  cup of sugar
- 5 tablespoons water

In a blender combine the eggs, milk, vanilla and the  $\frac{3}{4}$  cup of sugar and blend for about one minute.

In a small saucepan melt the  $\frac{1}{2}$  cup of sugar in 5 tablespoons of water and cook on top of the stove at medium heat until the sugar starts to get of a yellow color. This means that the sugar will get golden brown in seconds. As soon as this happens take it off the heat and pour into a double boiler pan or custard dishes. Spread the caramel evenly by tilting the pan or dish from side to side.

If using the double boiler pan, pour the egg mixture on the caramel and cook in the double boiler on top of the stove until a knife is inserted in it and it comes out clean.

If using the custard dishes, pour the egg mixture onto the caramel, cover the dishes with aluminum foil and place them on a shallow baking pan with water in it. Place the dishes in the oven at 350 degrees for 40 minutes.

### CHOOCH

---

(A fruit listed as *Lucuma hypoglauca* Standley)

While pounding this fruit to soften it up so that it is ready to eat you say **Hoken cheche, hoken takan, hoken cheche, hoken takan** (come out unripe, come out ripe...) over and over again.

## MEXICAN - MAYAN COOK BOOK

\*\*\*\*\*

---

### CREMAS DE COCO

(Coconut Cream)

1 can of coconut cream  
4 cup water  
1 cup cornstarch  
½ teaspoon salt  
food coloring

In a saucepan combine 3 cups of water, salt, and the coconut cream. Bring to the boiling point and set aside. Dilute the cornstarch in 1 cup of water and pour it slowly into the saucepan stirring well. Return the mixture to the burner and stir constantly until the mixture is cooked.

Pour half of the mixture into a pie plate. Add a few drops of food coloring to the remaining mixture and pour on top of the mixture already in the pie plate, taking care not to mix the two colors. Serve cold.

---

### KELBIL IXIM

(Pop Corn)

1 cup pop corn  
1 tablespoon cooking oil  
salt

Put the ingredients in a covered saucepan. Heat the contents on high heat, shaking constantly, until the kernels have popped.

---

### POCBIL PICH

(Roasted Pich)

Several Pich pods (pich = *Calliandra portoricensis*)

Place the **pich** pods in hot ashes. While waiting for the **pich** nuts to pop, say **pul a pic, pul a uex** (throw off your slip, throw off your underwear) continuously to encourage the **pich** nuts to pop. Suddenly, they will explode out of their pods. Gather up the popped nuts and eat them.

## MEXICAN - MAYAN COOK BOOK

\*\*\*\*\*

### MACAL

---

(Yautia)

2 pounds of macal (called yautia in some stores)  
½ stick of butter  
¼ cup of milk

Peel the macal like potatoes and cut into fat slices. Wash very well and boil on top of the stove until soft like potatoes. Discard the water and mash with the butter and the milk and serve instead of potatoes.

Macal is also very good if mixed with honey or maple syrup.

### DZIM

---

Yucca Fries

Cut the yucca into three inch long pieces. Take the peel off and cut into halves. Boil on top of the stove until soft. Discard the water and let cool. Cut in strips and deep-fry like potatoes.



## DRINKS





## MEXICAN - MAYAN COOK BOOK

\*\*\*\*\*

### ZA

---

(Fresh Sweet Corn Drink)

- 1 doz. ears sweet corn
- 4 cups water
- ½ teaspoon salt

Slice off the kernels and put in a blender. Grind very fine and put through a colander. Discard the hulls and cook on top of the stove stirring constantly until it thickens. When the first sign of boiling starts turn off the heat and put aside. Sweeten with sugar. This atole is good with tamales or just for a snack.

### ZACA ZA

---

- 1 cup of dried corn kernels
- 3 cups water
- sugar and salt to taste

Soak the corn in water overnight. Discard water and rinse a couple of times. Put it in a food processor if you don't have a **ca**, the Mayan grinding stone, to grind it with. At this stage the corn becomes **zacan** and it should have the consistency of a soft smooth dough. Dilute in three cups of water and put through a cheesecloth or a fine strainer. Put in a fairly big saucepan on top of the three stones and cook over a low fire stirring constantly until the boiling point is nearly reached. Add sugar and salt to taste. Serve with tamales for breakfast.

**Zaca Za** made this way cures Tosferina (whooping cough).

When a little boy or girl gets this sickness, grandmothers hang this drink on the front of the hut for nine nights. It is put in three little half gourds called **homa** (from the Crescentia cujete tree) which are used by the Mayans instead of cups.

The first **homa** contains the kernels of the corn with water. The second **homa** contains corn which is ground up. In the third **homa** is the **Zaca Za**. The **Zaca Za** is thrown away every night because it has absorbed the **kakaz ikoob**, the bad winds that give the sickness. If the sickness is stopped every night from entering the house, then the child will get well soon.

The first and second **homaob** are processed and given to the child to drink because these were touched by the good winds that fight the **kakaz ikoob**.

## MEXICAN - MAYAN COOK BOOK

\*\*\*\*\*

### ZACA

---

(“White Water”, a boiled dried corn drink)

- 1 cup corn kernels
- 3 cups water

Combine the contents in a saucepan and soak overnight. The next day discard the water and rinse the kernels with clean water. Place the kernels in the saucepan again and add 3 cups of water. Cook for one hour. Discard the water and wash the kernels once again. Grind in a hand grinder using enough water to keep the dough pliable. The dough may then be stored until ready to use. When making the drink mix a golf ball size with one cup of water. Add salt, honey, sugar, chili, or any other flavoring to taste.

### U Uklil Col

(The Drink of the Garden)

The corn drink **zaca** is used particularly in rituals and ceremonies. That is because it has not been cooked with lime and thus all the corn, hulls and all, is used in making the drink. Because **zaca** is not cooked with lime it is referred to as being **zuhuy**, virgin. Even in simple acts such as beginning to cut down the forest for making a garden or burning the brush after it has dried **zaca** is offered to the spirits who dwell in the area so they will not be offended, or in the case of burning the brush, so that the spirits will have a refreshing drink to cool their thirst. The dough is mixed with water in a bucket and then the bucket is hung on a tree for a while while work begins. Then after the appropriate amount of time the bucket is taken down again and the workers drink “what is left over”. The Mayans like to joke about getting the hulls stuck in their teeth.

## MEXICAN - MAYAN COOK BOOK

\*\*\*\*\*

### KEYEM

---

(Boiled Dried Corn Drink)

- 1 cup corn kernels
- 3 cups water
- ¼ cup slake lime

Combine the contents in a saucepan. Cook for 20 minutes. Let it cool. Wash the kernels well to remove the slake lime and hulls. Add 3 cups of water and cook for one hour. Grind in a hand grinder using enough water to keep the dough pliable. Grind as fine as possible and pat into a ball to sit overnight. The dough may then be stored until ready to use. When making the drink mix a golf ball size with one cup of water. Add salt, honey, sugar, chili, or any other flavoring to taste.

### SUSTENANCE FOR THE TRAVELER

For centuries **keyem** has been used by travelers as an easy to keep and carried food. One ball of about 3 inches round is made for each day the trip is expected to take. The balls are then wrapped in a cloth and packed into the **pau** (a woven bag with a shoulder strap) along with the various seasonings at hand as mentioned in the recipe above. Often this is the only food carried on the trip. As the days go by the balls begin to get an orangish mold growing on them, but this does not seem to hurt the taste of the **keyem** too much. When the **keyem** gets to this stage it is particularly good with sugar or honey in it.

### KEYEM BREAK

**Keyem** is used instead of coffee by the Maya in their work place, such as at the **col** (field, garden), called “milpa” in Spanish, yet another word borrowed from the Aztec language.

At 4 o'clock in the morning the father and his sons get up and get ready to go work in the **col**. Along with their machetes, they remember to carry along the ball of **keyem** in a **luch** (one half of a large gourd of the *Crescentia cujete* tree). As the sun dawns, they reach the **col** and start



## MEXICAN - MAYAN COOK BOOK

\*\*\*\*\*

working. At about 11 o'clock in the morning they get hungry and take a break. The father gets out the ball of **keyem** and dilutes it with well water. They like to drink it with salt and hot green chili peppers. There are usually chili peppers growing in the **col** along with other vegetables such as tomatoes, coriander, radishes, corn, etc., and these will be munched on while drinking the **keyem**. The break perks them right up and they keep working vigorously until about 2 o'clock in the afternoon.

### A POOR FAMILY'S MEAL

Ever since I remember my family used to weave palm leaves into long strips of about  $\frac{3}{4}$  inch wide which were then sold to the hat makers. These strips were sewn in a spiral manner to make straw hats. Each straw hat would require about 30 arms length of these strips. A skilful person could make 15 arms length in 5 hours, and would get 1 pesos for this work. This weaving does not require any tools except for a sewing needle which is used to tear the palm leaves into strips of about  $\frac{1}{4}$  inch wide. This kind of work is very tedious but is something which is easy enough for the whole family to do.

The palm leaves of the palm tree called **Xaan** are cut and dried. The leaves are cut before they open up so that the inside of the leaf is still white. This is done on a regular basis so the palm leaves are always fresh. The job of weaving the palm leaves is done in a cave called **Zazcab**. The weaving is done there because the temperature and humidity is just right to make the palm leaves easy to handle.

The first time I remember weaving palm leaves was when I was young, about 9 years old. My father announced one morning that he was going on a trip to the city of Mérida, a trip of about 4 hours away. The only way to get there at that time was the steam train which stopped at all of the little towns along the way. The train left our town of Ticul at 5 in the morning and came back at 4 or 5 in the afternoon, depending on how many cows, drunks, or other such got in the way of the train on its way back. I remember my father walking the  $1\frac{1}{2}$  blocks that separated our house from the train station and getting on the train. Later that day when the train was supposed to return we children went to wait for him at the train station. The train came and went but my father was not on the train. For the next six months some of us went every day to the station to wait but still he did not return.

At the beginning of my father's absence our family had no money and very little to eat. This was true in part because my mother was a very fertile woman and had a baby every two years without fail. Therefore my mother was always nursing or pregnant all the time. Needless to say much of the time what little money there was was spent on medicines or doctor's fees instead of for food. Because my father left us without any money my mother decided that at least we could all work making the palm leaf strips. We happened to have a **zazcab** in our back yard. Every morning we went into the **zazcab** and started weaving. After being in the cave for an hour or so the young people became restless and wanted to stop making the strips. Grandmother

## MEXICAN - MAYAN COOK BOOK

\*\*\*\*\*

or Mother then started to tell stories which they stressed with a serious face were all true. Then when lunch time came my mother would bring in a pot of **keyem**, which was served with salt and a bunch of green chili peppers. That was it! After lunch we would work a couple of hours longer and then call it a day. The next morning Mother took our work to the market to sell and then the whole process would start all over again.

One day while I was working alone with my Grandmother in the **zazcab** a little blue tail fly, called **dzindzin** in Mayan, started buzzing about. My grandmother said to me:

“I know what that little blue tail fly is saying. I am going to tell you what it says. It is saying this:”

(The following lines are chanted)

**Buenos dias mam.**  
**Baax a kati mam?**  
**Talen in mahant hundzit ic mam.**  
**Baaxtial tech mam?**  
**Utial in zot tu hol u uit in uabil mam.**  
**Drrrrrrum!**

Good day woman.  
What do you want, woman?  
I have come to borrow a chili pepper, woman.  
What do you want it for, woman?  
So that I can stick it in the ass hole of my grandchild, woman.  
Drrrrrrum!



MEXICAN - MAYAN COOK BOOK

\*\*\*\*\*

IZ UL

---

(Camote Atole)

sweet corn  
sugar  
salt

Cut the grains off the sweet corn. Grind the corn and mix in the sugar and salt. Put the mixture in a saucepan and set to boil. Just as it begins to boil take it off the fire. Let cool and drink.

IZ YETEL ZA

---

(Camote and Atole)

sweet corn  
Sweet potato  
sugar  
salt

Cut the grains off the sweet corn. Grind the corn and mix in the sugar and salt. Put the mixture in a saucepan and set to boil. Just as it begins to boil take it off the fire. Let cool and drink.

TUMBEN ZA / U ZAIL AK NAL

---

(New Atole / Atole made of Sweet Corn)

sweet corn  
sugar  
salt

Cut the grains off the sweet corn. Grind the corn and mix in the sugar and salt. Put the mixture in a saucepan and set to boil. Just as it begins to boil take it off the fire. Let it cool and leave it out over night. The next day either drink cold or warm up to drink warm.

## MEXICAN - MAYAN COOK BOOK

\*\*\*\*\*

### KA

---

(Pinole, Another Boiled Dried Corn Drink)

- 1 cup corn kernels
- 3 cups water
- 1 tablespoon salt

Roast the corn kernels in a frying pan and then grind them into a fine flour. Combine them with the water and salt in a saucepan. Cook for one hour. Add honey, sugar, chili, or any other flavoring to taste.

### UALAK

---

(A Drink made from **Pimpim Uah**)

- 1 pimpim uah 8 inches round by  $\frac{3}{4}$  inch thick
- 2 cups water
- salt and chili pepper to taste

Make the **pimpim uah** as described in the Section on Tortillas. Mash the **pimpim uah** in the water. Add salt. Munch on the chili pepper while drinking. Alternatively, add honey and/or ice.

**Ualak** is usually made while the tortillas are being made. If the people making the tortillas or the children hanging about get hungry then a **pimpim uah** is made from the **zacan** and is immediately mashed in water in a **luch**. This will get everybody going until dinner is served.

## MEXICAN - MAYAN COOK BOOK

\*\*\*\*\*

### CHUCUA

---

(Hot Chocolate)

#### U UAHIL CHUCUA (Chocolate Tortilla)

- 1 pound roasted cocoa beans
- 1 stick cinnamon

Chop up the cinnamon. Grind the cocoa beans and cinnamon together in a hand grinder. Add a little water while grinding so that the ground beans come out as a dough of a smooth consistency. Make golf ball sized balls from the dough and flatten them into tortillas 3 inches in diameter. Store in a cool place until ready to use.

#### CHUCUA (Chocolate Drink)

- 1 chocolate tortilla
- 2 cups boiling water

Break the chocolate tortilla into pieces and put them in a blender. Pour in the boiling water. Blend until the pieces have dissolved. Add sugar, honey, or sweetened condensed milk to taste. Blend again. Make sure that there is plenty of foam, as this adds to the flavor of the drink.

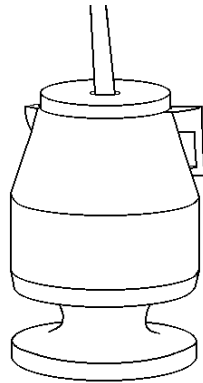

Above is the **bokob che** used in most Mayan households to blend the chocolate and make it foam. To the right is the ancient way of making the chocolate drink foam.



## MEXICAN - MAYAN COOK BOOK

\*\*\*\*\*

### FRUIT DRINKS

In Yucatan it is customary to serve a fruit drink with dinner. These fruit drinks are made with fresh fruits, water, and sugar.

---

#### U HAIL SANDIA

(Watermelon Drink)

4 cups watermelon pulp without the seeds  
4 cups water  
sugar to taste  
ice cubes

Put the watermelon, water, and sugar in a blender. Alternatively mash the mixture with a potato masher. Add the ice cubes and serve.

This is the same recipe for other fruits such as papaya, melon, pineapple, etc. An alternative to using water is using a carbonated beverage such as seltzer water, ginger ale, or club soda.



Don Lio and Mam Goya harvesting papaya or **put**

## MEXICAN - MAYAN COOK BOOK

\*\*\*\*\*

### LIQUADO DE SANDIA (Watermelon Drink)

- 1 cup watermelon juice
- 1 cup Ginger Ale

Cut about 2 cups the watermelon into cubes. Put in a blender for a few seconds. Strain out the seeds and pulp. Mix with the Ginger Ale and serve with ice.

---

### PLATANO CON LECHE

(Banana Milk)

- 3 bananas
- ¼ cup sweetened condensed milk
- ½ cup regular milk
- 6 ice cubes

Put all the ingredients in a blender and blend for 15 seconds or until the ice cubes are finely chopped.

---

### PIÑA COLADA

(Strained Pineapple)

- ½ can pineapple juice
- 2 oz. cream of coconut
- 6 ice cubes

Put all the ingredients in a blender and blend for 15 seconds or until the ice cubes are finely chopped.

## MEXICAN - MAYAN COOK BOOK

\*\*\*\*\*

### HORCHATA

---

(Rice Drink)

- 1 cup rice
- 2 cup sugar
- 15 peeled roasted almonds
- 1 tablespoon cinnamon
- 6 cups water

Soak with the water the rice and cinnamon overnight. Add the almonds and blend on high speed until the rice is diluted. Put this through a cheesecloth or a very fine strainer and set aside.

Add one cup of water to the sugar and boil on top of the stove. When the sugar starts to thicken add it to the rice and mix very well.

Add ice cubes and serve.

This drink is used instead of coca-cola in fiestas or other such gatherings. Religious groups like the Bahi usually give free horchata and tacos after sermons. This way they get their thatched roof church packed with the Mayan villagers.

### ARROZ CON LECHE

---

(Rice with Milk Drink)

- 4 cups cooked rice
- 1 can sweeten condensed milk
- ½ teaspoon salt
- ½ teaspoon cinnamon
- 4 cups water

In a saucepan combine all the ingredients and boil for 20 minutes.