



CRUISER LINE

56 50 46 41 40S 37 33



BAVARIA
SAILING



HIGH QUALITY

BAVARIA Yachts has one of the highest quality and safety standards in the entire yacht construction industry, together with state of the art style and design. One reason for this is our close collaboration with the leading construction and design companies in the world. Together, we develop high-performance models which easily surpass all CE requirements. Additionally, our yachts, as well as our production facility, are regularly inspected and certified by Germanischer Lloyd.

STATE OF THE ART

BAVARIA is one of the most successful yacht building companies in the world. In dialogue with our customers, we develop pioneering sail and motor yachts which combine dynamism, comfort and value stability – technical perfection for all those who love life on the water. When building our yachts, we benefit from our long-standing experience, the specialist expertise of our employees and one of the world's most modern series production facilities. We guarantee delivery and local service through our global distribution network.



CRUISER LINE

Luxury and performance

Experience freedom, luxury and exceptional sailing performance with the new line of BAVARIA CRUISERS. With a choice of seven models ranging from 33 feet to 56 feet, you can customise your boat from the numerous interior layout and design options. We have developed each model of the CRUISER line in close cooperation with Farr Yacht Design USA, one of the world's leading naval architects. The result is a unique yacht line that combines comfort, safety and utmost structural integrity with state-of-the-art hull shapes, autonomous design and perfect handling.

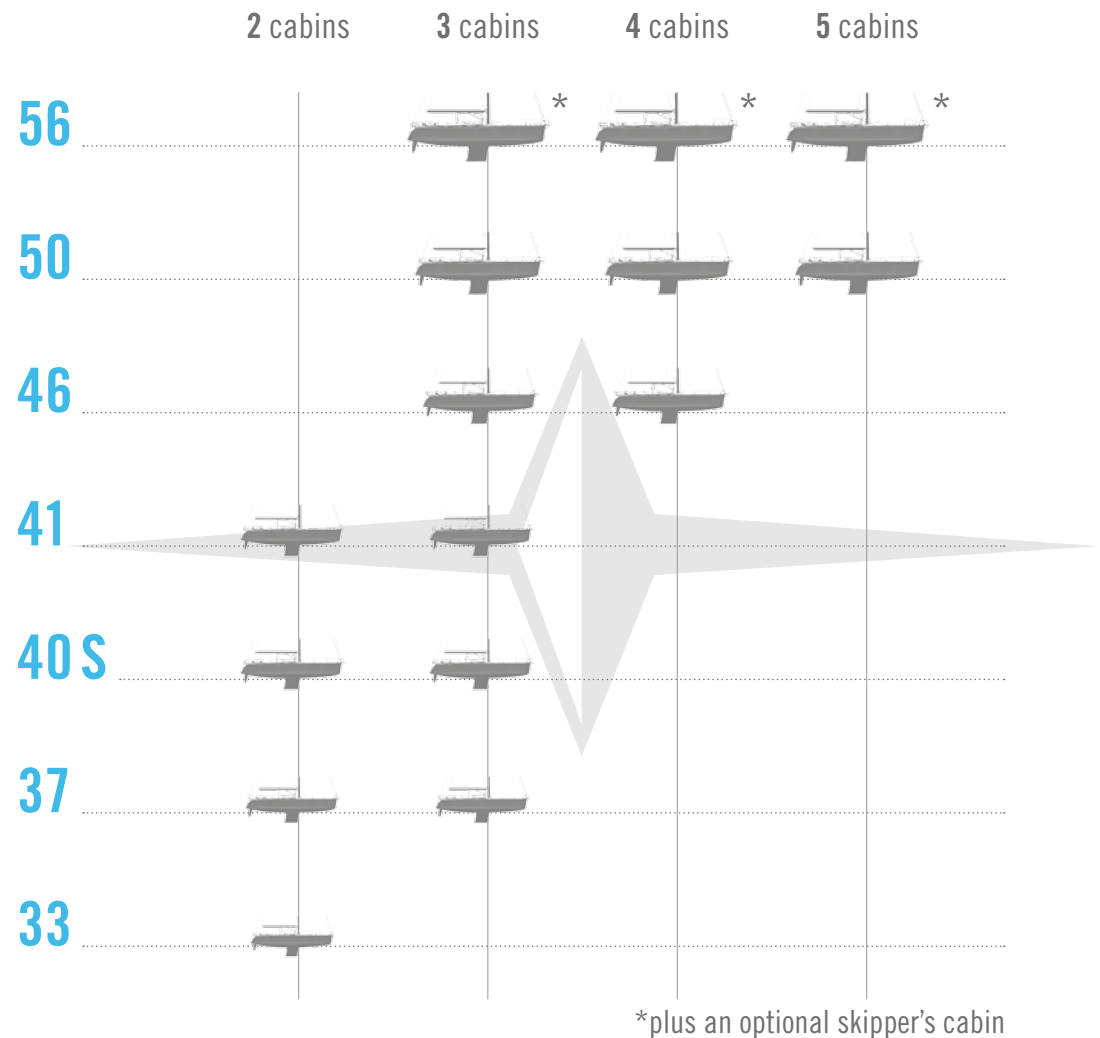

56



CRUISER 56

Luxury redefined

As the flagship of the CRUISER line, the CRUISER 56 enters new dimensions. It offers an incredible amount of space along its length of nearly 17 metres – including a spacious dinghy garage. The variable cockpit provides plenty of room to move. The handling is quite impressive, too: despite its size, the CRUISER 56 can be sailed without a hitch.



56 | Magnificent interior



Thanks to the cooperation with the British design studio Design Unlimited, the CRUISER 56 has the look of a genuine yacht, inside and out. Fine wood, modern shapes and plenty of light create a warm atmosphere. In the aft cabins you instantly notice the extra large beds, which promise perfectly comfortable sleep.



3-cabin version*



4-cabin version A*



4-cabin version B*



4-cabin version C*



5-cabin version A*



5-cabin version B*

*Optional skipper's cabin, sail storage locker as standard

56 | Technical data



Mainsail	77 m ²
Foresail	68 m ²
Gennaker	198 m ²
I	19.88 m
J	6.51 m
P	19.25 m
E	6.76 m

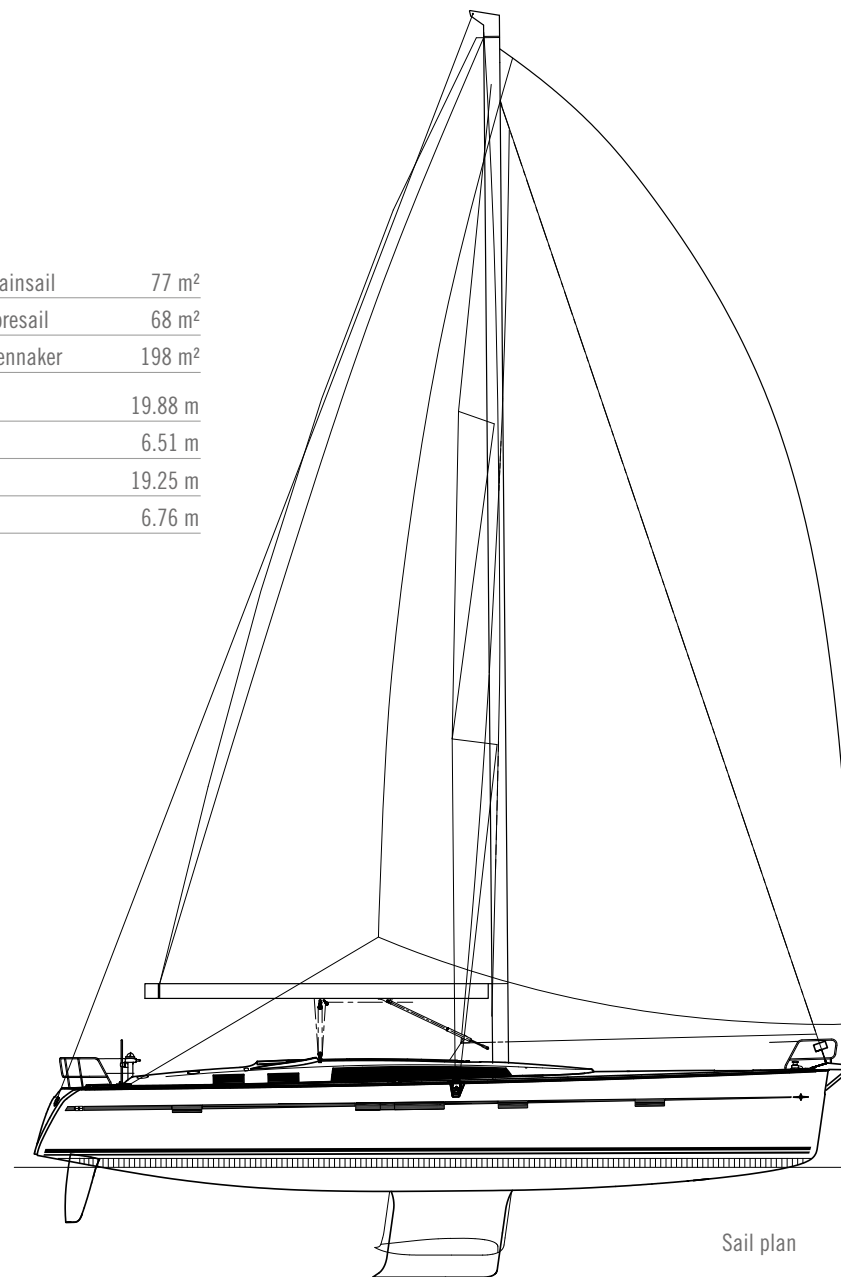

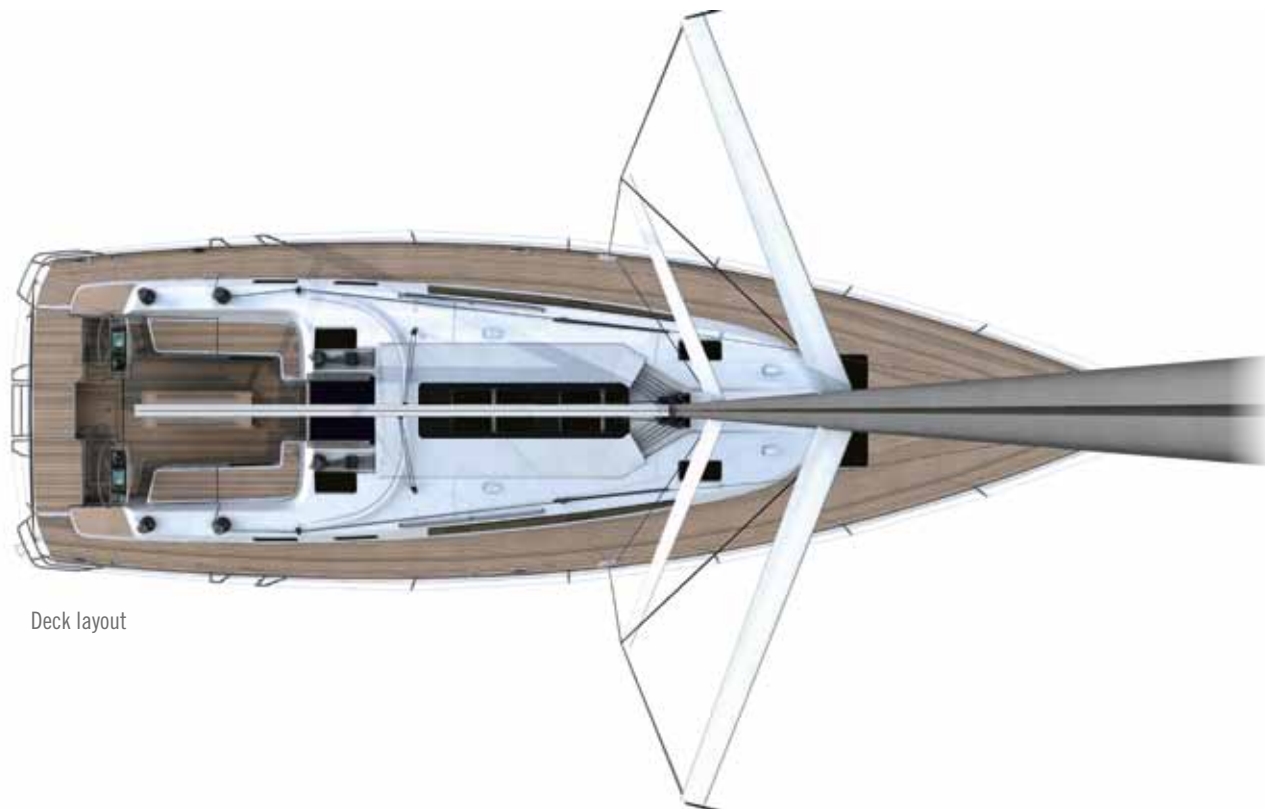

Deck layout

Length overall	16.75 m
Length hull	16.16 m
Length waterline	15.63 m
Beam overall	4.76 m
Draught standard (option)	2.46 m (2.02 m)
Light weight displacement	18,596 kg
Ballast	5,500 kg
Engine	Yanmar Shaftdrive 4JH4-HTE
Engine power	74 kW (100 PS)

Fuel tank (approx.)	280 l
Water tank (approx.)	690 l
Cabins	3*/4*/5*
Berths	6/8/10
Height in salon	2.06 m
Mainsail (battened) and fore sail	145 m ²
Height of mast above waterline	23.25
Passengers	16
CE category	A

All data is subject to change without notice and given without warranty.

*plus an optional skipper's cabin



50



CRUISER 50



Classic cruising in modern style

Elegant lines, carefully designed details and room for up to ten berths – the CRUISER 50 is stunning at first sight. The Owner's Version can boast of being the most spacious yacht in its class. Living, sleeping, cooking – life on board has never been more comfortable. The design of the modern cockpit and the stern, which can be lowered to form a bathing platform, is also strikingly generous.

50 | Your yacht, your choice

When it comes to designing the interior, there are no limits to the owner's imagination. You can choose between a five-, four- or three-cabin version (equipped with three heads and separate shower). Especially impressive is the salon height of no less than 2.11 m. It is one of the elements that ensure the unique sense of spaciousness that you get on board.





3-cabin version



4-cabin version A



4-cabin version B



5-cabin version

50 | Technical data



Mainsail	67 m ²
Foresail	60 m ²
Gennaker	186 m ²
I	19.50 m
J	6.10 m
P	18.52 m
E	6.17 m

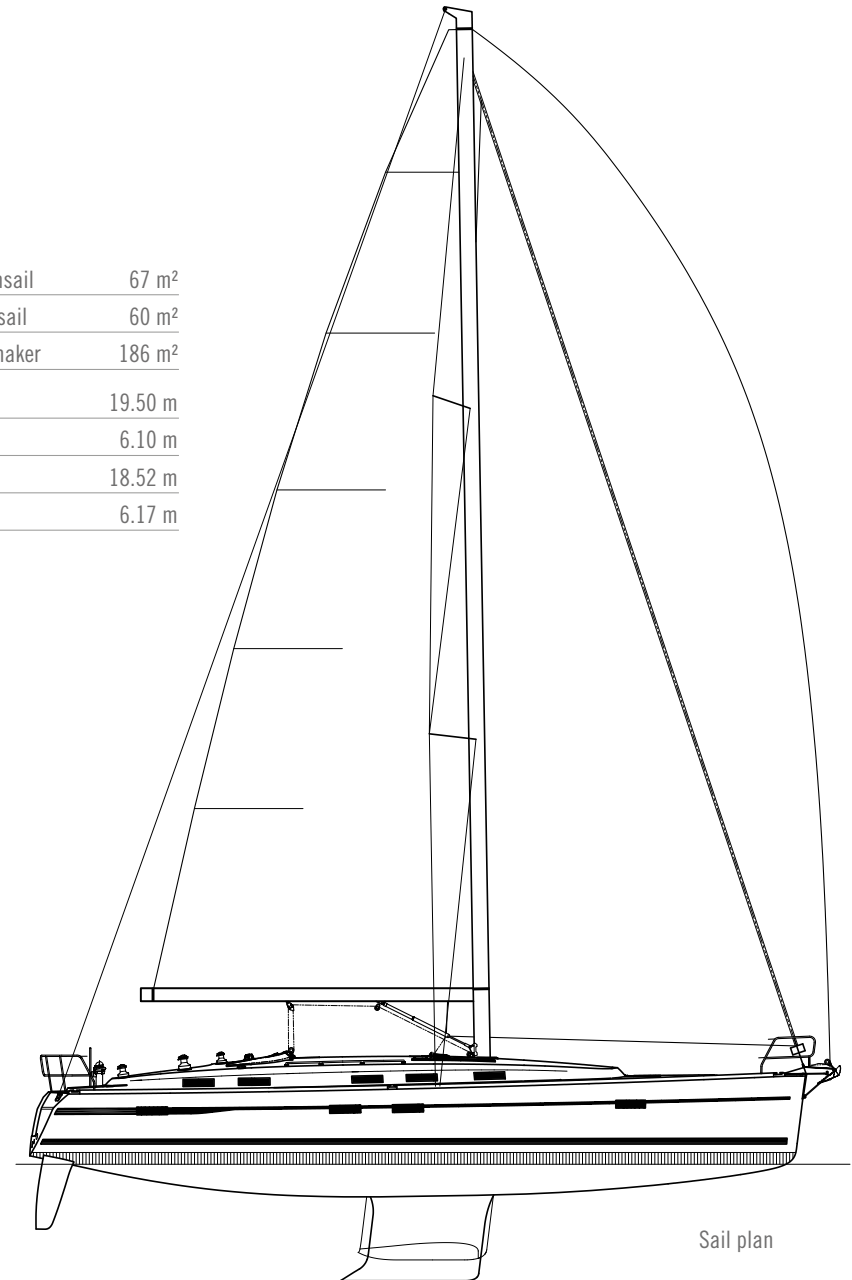

Twin rudders

Sail plan



Deck layout

Length overall	15.57 m
Length hull	14.99 m
Length waterline	13.86 m
Beam overall	4.67 m
Draught standard (option)	2.25 m (1.85 m)
Light weight displacement	14,100 kg
Ballast	4,600 kg
Engine	Volvo-Penta Saildrive D2-75
Engine power	55 kW (75 PS)

Fuel tank (approx.)	300 l
Water tank (approx.)	560 l
Cabins	3/4/5
Berths	6/8/10
Height in salon	2.11 m
Mainsail (battened) and fore sail	131 m ²
Height of mast above waterline	22.35 m
Passengers	12
CE category	A

All data is subject to change without notice and given without warranty.



46



CRUISER 46

Innovation through detail

With its impressive hull and striking design, the CRUISER 46 is a state-of-the-art yacht. The roomy cockpit area also boasts generous amounts of space: ergonomically arranged seating bays ensure optimal comfort for all crew members, while the innovative twin wheel steering provides superb handling and all-round visibility.



46 | Comfort by design



The CRUISER 46's interior is characterized by openness, comfort and additional space. Also the spacious master cabin has a dividing bulkhead. This bulkhead allows the 4-cabin version to be transformed into a 3-cabin version and back again as needed.



3-cabin version

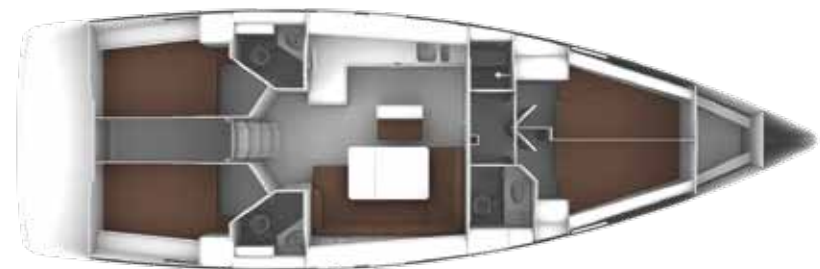

4-cabin version

46 | Technical data

Mainsail	56 m ²
Foresail	51 m ²
Gennaker	150 m ²
I	17.91 m
J	5.53 m
P	17.19 m
E	5.55 m

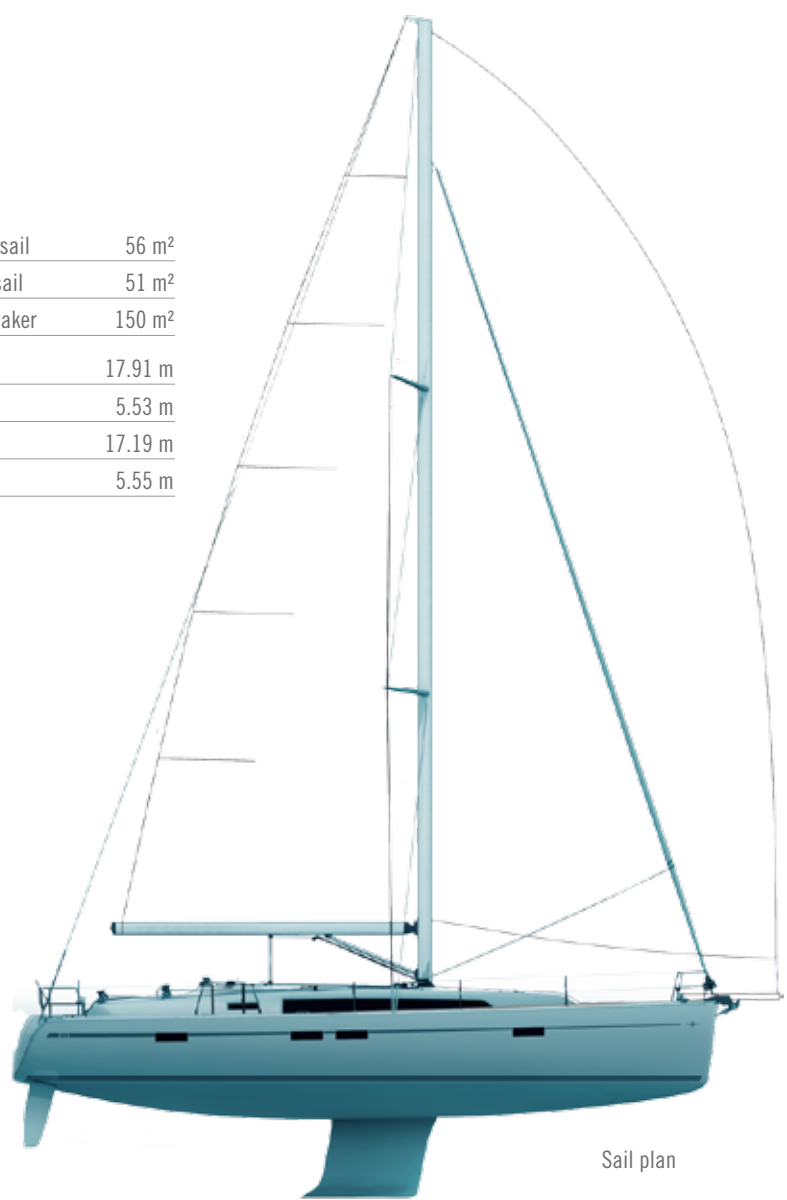

Sail plan



Deck layout

Length overall	14.27 m	Fuel tank (approx.)	210 l
Length hull	13.60 m	Water tank (approx.)	360 l
Length waterline	12.74 m	Cabins	3/4
Beam overall	4.35 m	Berths	6/8
Draught standard (option)	2.10 m (1.73 m)	Height in salon	2.05 m
Light weight displacement	12,600 kg	Mainsail (battened) and fore sail	108 m ²
Ballast	3,490 kg	Height of mast above waterline	20.75 m
Engine	Volvo-Penta Saildrive D2-55	Passengers	10
Engine power	41 kW (55 PS)	CE category	A

All data is subject to change without notice and given without warranty.



Twin rudders

41



CRUISER 41



Enhanced cruising comfort

The CRUISER 41 exudes an air of comfort and warmth. The new, clean deck design features elegant lines and greater standing room in the forward cabin – all details that promote greater comfort and relaxation.

41 | Relaxation for the whole family



Below deck, the CRUISER 41 is all about luxurious comfort and generous amounts of space. Her optimised hatches and the large side coachroof windows allow a maximum amount of light into the interior, making the living quarters even more comfortable.

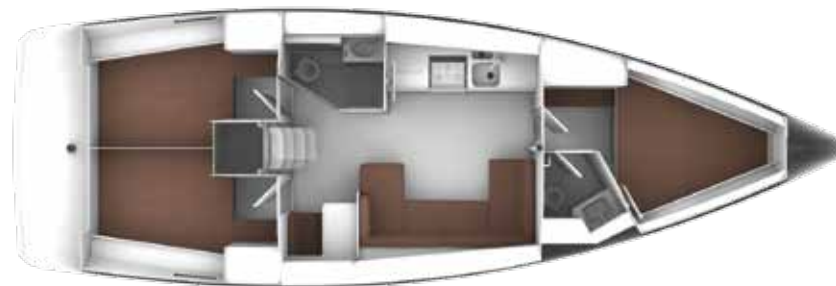

3-cabin version

41 | Technical data

Mainsail	48 m ²
Foresail	34 m ²
Gennaker	102 m ²
I	15.83 m
J	4.20 m
P	15.36 m
E	5.27 m



Sail plan

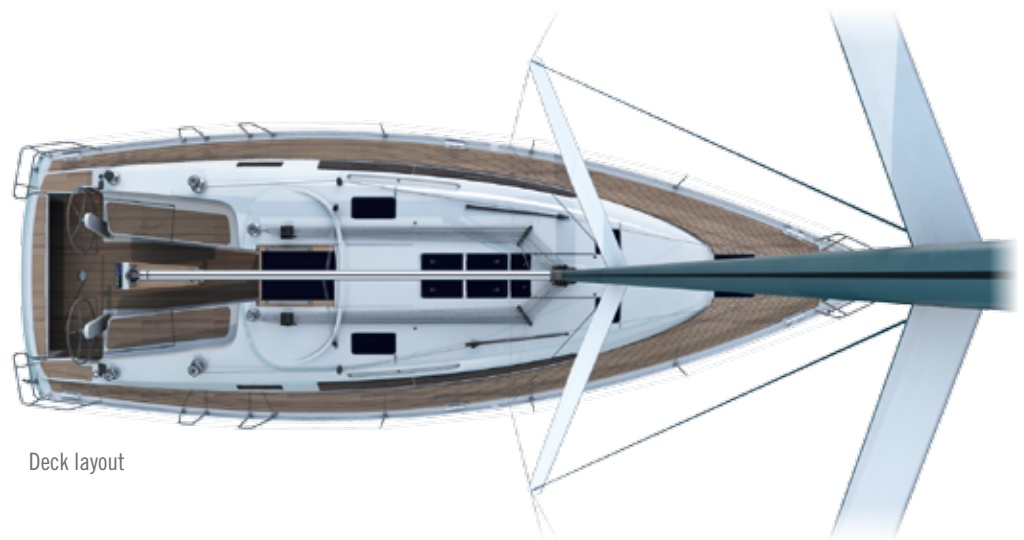

Deck layout

Length overall	12.35 m	Fuel tank (approx.)	210 l
Length hull	11.99 m	Water tank (approx.)	210 l
Length waterline	10.75 m	Cabins	2/3
Beam overall	3.96 m	Berths	4/6
Draught standard (option)	2.09 m (1.69 m)	Height in salon	1.94 m
Light weight displacement	8,680 kg	Mainsail (battened) and fore sail	82 m ²
Ballast	2,409 kg	Height of mast above waterline	18.68 m
Engine	Volvo-Penta Saildrive D1-30	Passengers	8
Engine power	20.9 kW (28 PS)	CE category	A

All data is subject to change without notice and given without warranty.

S 40



CRUISER **S**⁴⁰

Sail like a pro

We have cooperated closely with Farr Yacht Design USA to equip the CRUISER 40 for professional regattas. The result is the CRUISER 40 S – an agile sailing yacht combining comfort and true racer genes. It has a deeper keel, a larger sail plan with performance mast and boom, performance fittings, carbon spinnaker boom, composite wheels, jumbo displays at the mast and many other extras which are indispensable for ambitious sailors.



The CRUISER 40 S is the official yacht of the Match Race Germany. In this classic, the best match racers in the world compete for the German Grand Prix, collecting valuable points for the World Match Racing Tour.



40 S | Technical data



Length overall	12.35 m
Length hull	11.99 m
Length waterline	10.75 m
Beam overall	3.96 m
Draught standard	2.30 m
Light weight displacement	8,140 kg
Ballast	2,736 kg
Engine	Volvo-Penta Saildrive D1-30
Engine power	20.9 kW (28 PS)
Fuel tank (approx.)	210 l
Water tank (approx.)	210 l
Cabins	2/3
Berths	4/6
Height in salon	1.94 m
Mainsail (battened) and fore sail	95 m ²
Height of mast above waterline	19.18 m
Passengers	8
CE category	A

All data is subject to change without notice and given without warranty.

Mainsail	56 m ²
Foresail	40 m ²
Gennaker	122 m ²
I	15.83 m
J	4.22 m
P	15.80 m
E	5.66 m

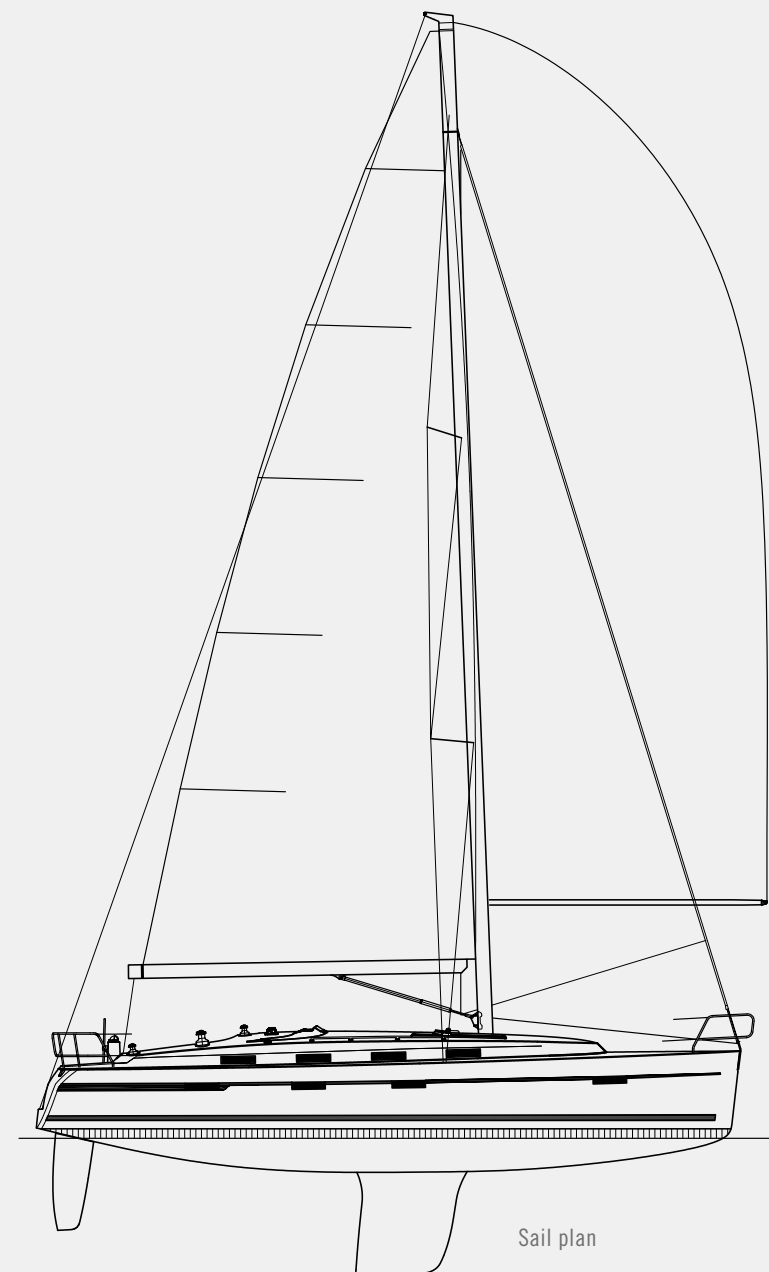

Sail plan



Deck layout



2-cabin version



3-cabin version





CRUISER 37

Smart sailing

Like all new BAVARIA yachts, the CRUISER 37 has outstanding sailing properties. Other highlights include three coachroof windows, large panorama windows, a new deck design and the largest bathing platform on the market.



37 | Elegant interior



The spacious salon has a new storage concept for optimal organisation of life on board with multiple crew members. The new panorama windows allow plenty of light into the interior and together with the new coachroof windows help create a sense of greater spaciousness. The high-quality furnishings come in three different colours with a range of upholstery options.



2-cabin version



3-cabin version

37 | Technical data

Mainsail	41 m ²
Foresail	27 m ²
Gennaker	82 m ²
I	14.10 m
J	3.73 m
P	13.62 m
E	5.10 m

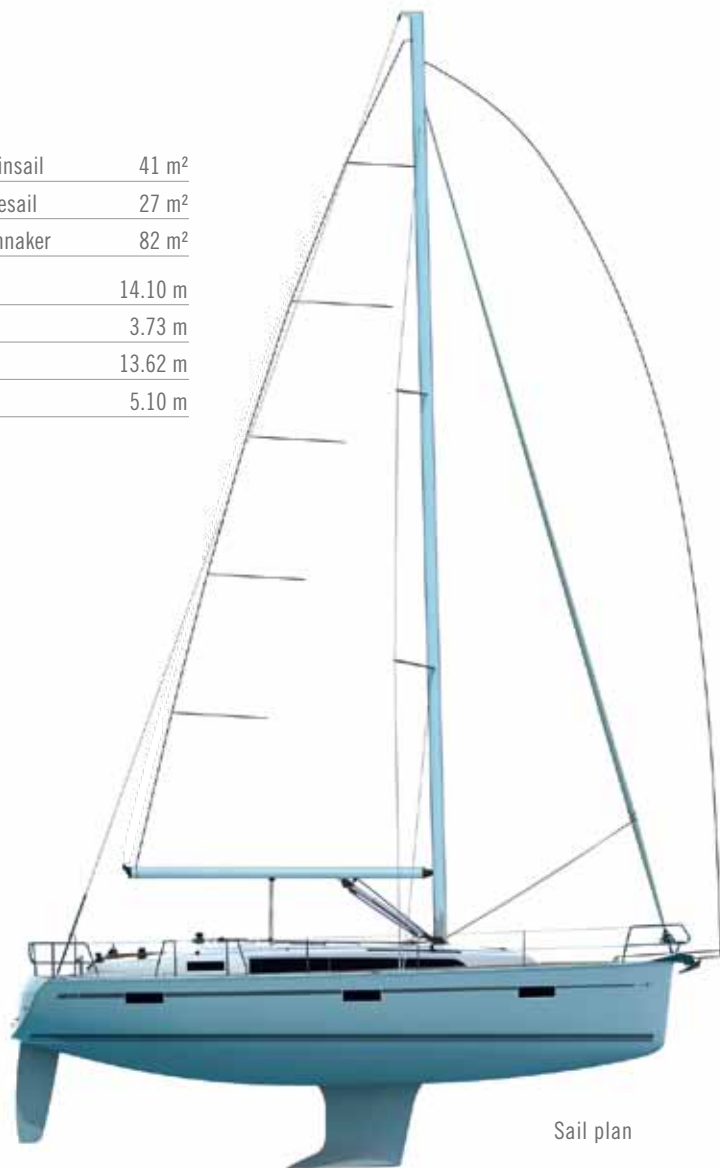

Sail plan

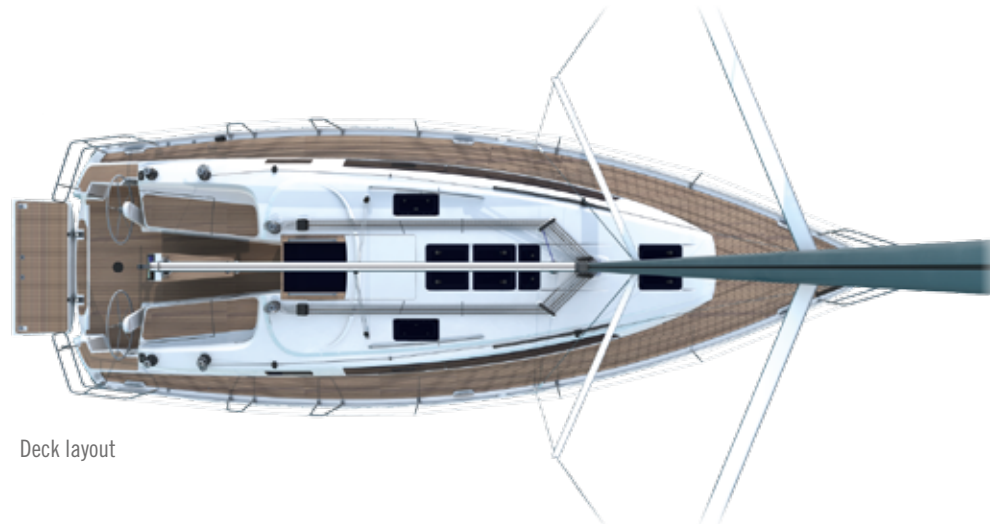

Deck layout

Length overall	11.30 m	Fuel tank (approx.)	150 l
Length hull	10.90 m	Water tank (approx.)	210 l
Length waterline	10.22 m	Cabins	2/3
Beam overall	3.67 m	Berths	4/6
Draught standard (option)	1.95 m (1.63 m)	Height in salon	1.95 m
Light weight displacement	7,000 kg	Mainsail (battened) and fore sail	65 m ²
Ballast	2,080 kg	Height of mast above waterline	16.82 m
Engine	Volvo-Penta Saildrive D1-20	Passengers	8
Engine power	13.9 kW (19 PS)	CE category	A

All data is subject to change without notice and given without warranty.



CRUISER 33

The next generation

New deck, new rig, new keel – the exterior design of the newly constructed CRUISER 33 makes sailors' hearts beat faster. There is comfortably enough room for helmsman and crew on the ergonomic cockpit benches. What is more, they provide clear access to the bathing platform, the largest in this class. The sailing properties exceed the requirements of any cruise sailor by far. Even so, single-handed sailing is easily possible as well – thanks to the exemplary handling and the easy access to the winches.



33 | Comfort writ large



The interior is marked by high-grade materials and first-rate carpentry. The amount of space and size of the beds are unique in this class. The large panorama windows allow plenty of light into the interior, and they grant a magnificent view to boot. The side windows are equipped with additional hatches.

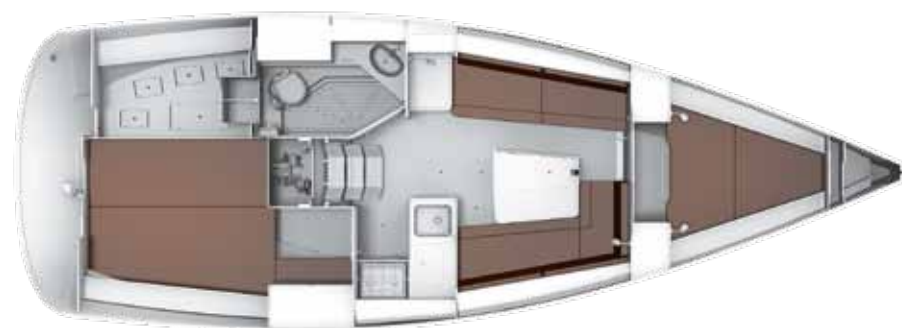

2-cabin version

33 | Technical data



Mainsail	29 m ²
Foresail	22 m ²
Gennaker	70 m ²
I	12.34 m
J	3.50 m
P	11.79 m
E	4.12 m

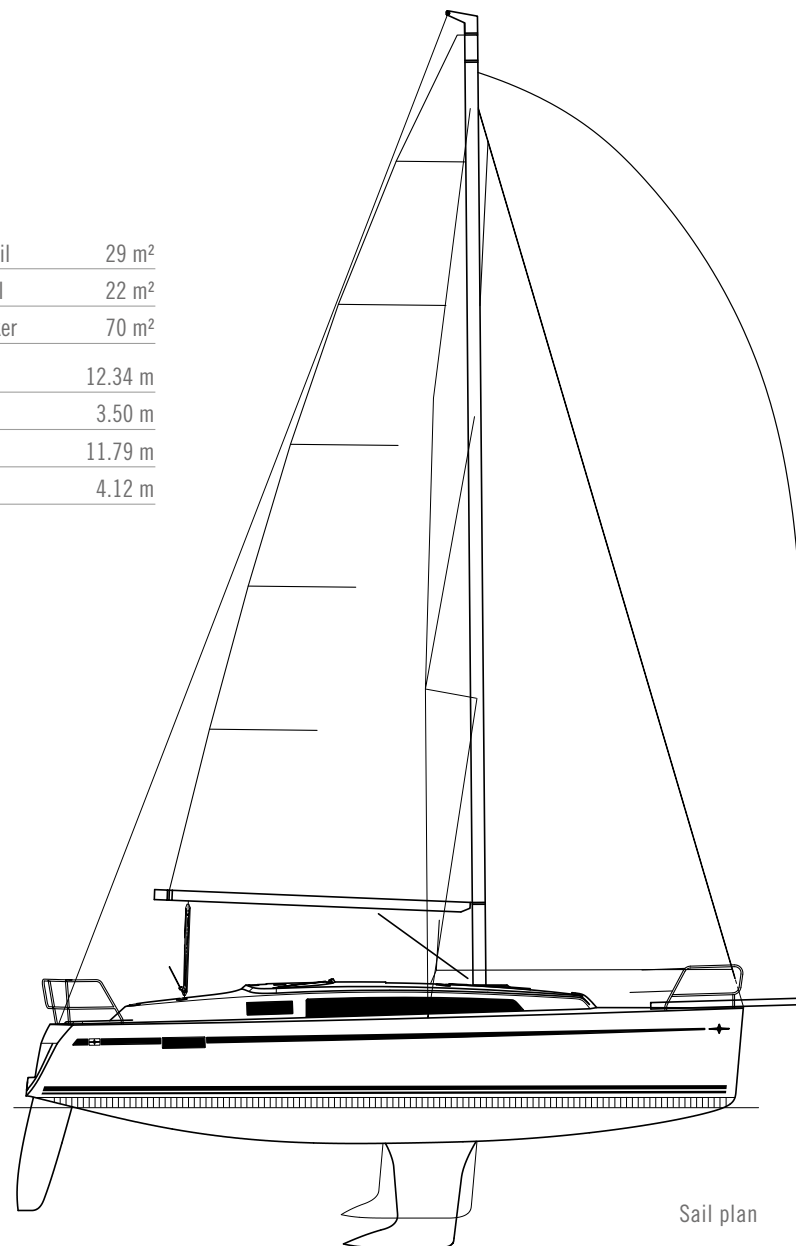

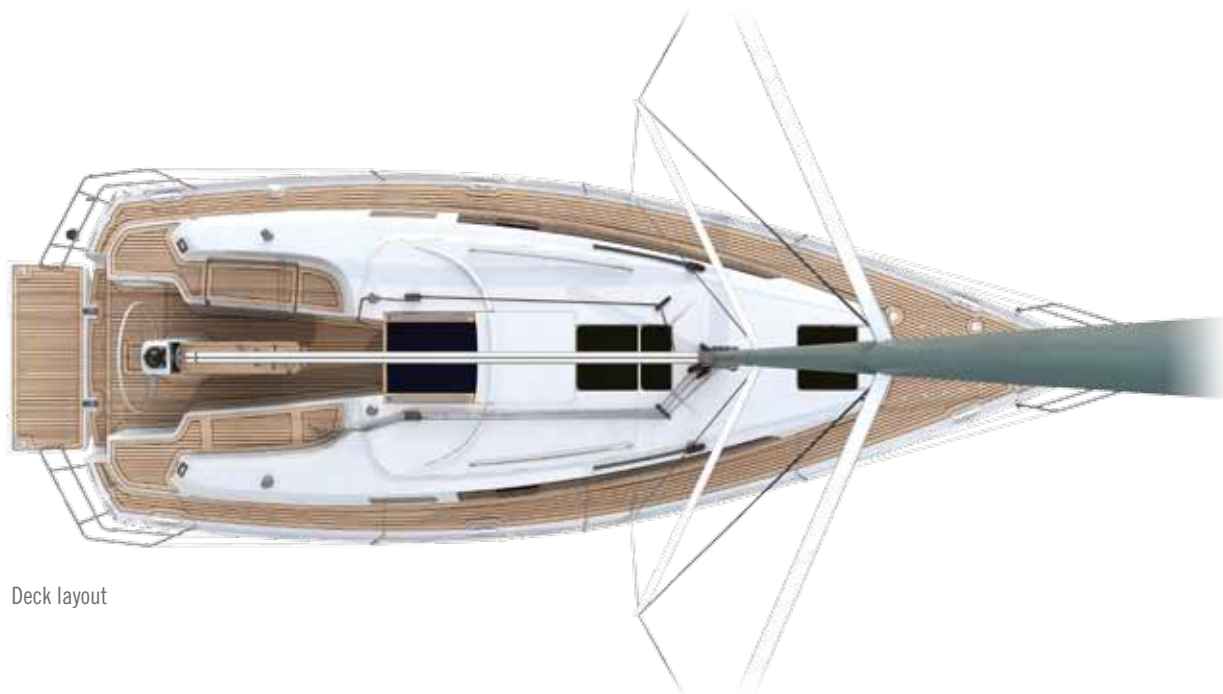

Deck layout

Length overall	9.99 m
Length hull	9.75 m
Length waterline	8.85 m
Beam overall	3.42 m
Draught standard (option)	1.95 m (1.50 m)
Light weight displacement	5,200 kg
Ballast	1,300 kg
Engine	Volvo-Penta Saildrive D1-20
Engine power	13.3 kW (18 PS)

Fuel tank (approx.)	150 l
Water tank (approx.)	150 l
Cabins	2
Berths	4
Height in salon	1.84 m
Mainsail (battened) and fore sail	51 m ²
Height of mast above waterline	14.80 m
Passengers	6
CE category	A

All data is subject to change without notice and given without warranty.





FEATURES

First-rate equipment

Attention to detail separates one class of yacht from another and the CRUISER line is a class apart through innovative and functional solutions. The highlight is the swimming platform which, when closed, serves as a comfortable seat for the helmsman and the crew.



The **twin-steering system** of the CR 56, 50, 46, 41 and 37. Good cover through high **spray hoods*** and **complete biminis*** against wind and weather



Bathing platform spans the entire width of the stern



Large **cockpit locker** space



All **halyards** and **lines** are led directly into the cockpit (ill. CR 41) for easy and centralised handling



The **genoa tracks** are positioned on top of the coach roof, ensuring uncluttered decks as well as excellent up-wind characteristics

*Option

Features



Ergonomically placed **halyards** and **sheet winches**



Roller furling **mainsail** and **headsail** ensure safe and easy handling for any size of boat



Flush hatches ensure an uncluttered deck



Twin rudders with the CR 56, 50 and 46

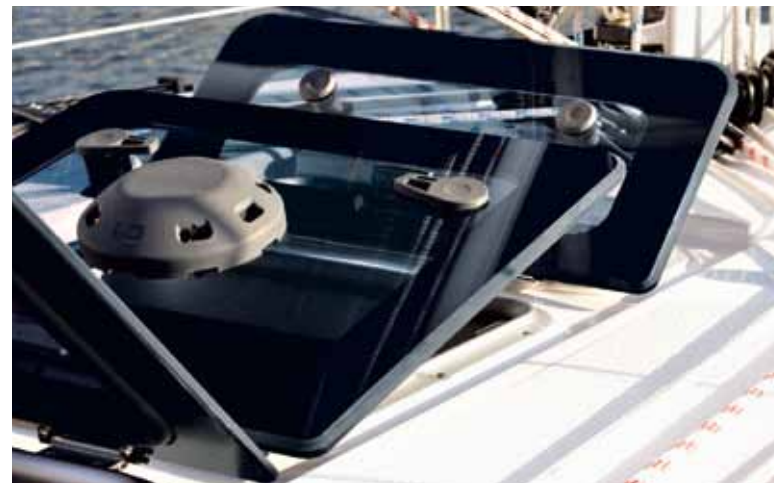

Thanks to the **various hatches** the interior benefits from excellent ventilation and light.



Flush-mounted portlights in the side windows



optional gennaker bowroller*



BAVARIA dual mainsheet, mid-boom sheeting system – enables exact trimming without traveller as well as safe gybing



The GPS plotter is mounted in the optional cockpit table*



Perfect position for the helmsman thanks to fold-out foot stands (CR 56, 50 and 46)

*Option



Interior

Veneer



Mahogany



Teak



Oak

Flooring



Oak nature



Walnut nature



Walnut



Chestnut



Ocean Line



Ocean Line red

Panelling



Mocca



Meteor

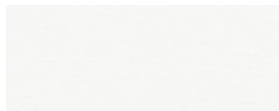

Ice White

Upholstery (fabric)



Standard Creme



Standard Blue



Comfort Creme



Comfort Blue



Comfort Brown



Comfort Orange

Upholstery (leather)



Leatherette White



Leatherette Brown



Leatherette Creme Velour

Mattresses



New Drell



Standard Creme



Standard Blue



Greybrown

Exterior

Flooring



Teak



DuraDeck

Hull colour



White



Grey

Sunbrella



Dove



Melon

Hood



Stone



Fox



Navy



Sand



Black



Dove

Combinations for the interior

		Veneer		Flooring						Panelling			Upholstery							
				Oak nature	Walnut nature	Walnut	Chestnut	Ocean Line	Ocean Line red	Mocca	Meteor	Ice White	Standard Creme	Standard Blue	Comfort Creme	Comfort Blue	Comfort Brown	Comfort Orange	Leatherette White	Leatherette Brown
CRUISER 33	Standard	Mahogany	●	-	-	○	○	-	-	-	-	●	●	○	○	○	○	○	○	○
	Option	Teak	-	●	-	-	○	-	-	-	-	●	●	○	○	○	○	○	○	○
	Option	Oak	-	●	-	-	○	-	-	-	-	●	●	○	○	○	○	○	○	○
CRUISER 37/41/46/50	Standard	Mahogany	●	-	-	○	-	○	-	-	-	●	●	○	○	○	○	○	○	○
	Option	Teak	-	-	●	-	○	-	-	-	-	●	●	○	○	○	○	○	○	○
	Option	Oak	-	-	●	-	-	○	-	-	-	●	●	○	○	○	○	○	○	○
CRUISER 56	Standard	Mahogany	●	-	-	○	○	-	●	-	●*	●	●	○	○	○	○	○	○	○
	Option	Teak	-	●	-	-	○	-	●	-	●*	●	●	○	○	○	○	○	○	○
	Option	Oak	-	●	-	-	○	-	-	●	●*	●	●	○	○	○	○	○	○	○

*optionally available only for salon panels

		Mattresses		Upholstery							
				Standard Creme	Standard Blue	Comfort Creme	Comfort Blue	Comfort Brown	Comfort Orange	Leatherette White	Leatherette Brown
CRUISER 33/37/41/46/50/56	New Drell (Standard)	●	●	●	●	●	●	●	●	●	●
	Standard Creme (Option "Living")	○	-	○	-	-	-	-	○	-	○
	Standard Blue (Option "Living")	-	○	-	○	-	-	-	-	-	-
	Greybrown (Option "Living")	-	-	-	-	○	○	-	-	○	-

Standard	●
Option	○
Not available	-

Please select the upholstery cover first and then the matching mattress cover.



BAVARIA Yachtbau GmbH · Bavariastrasse 1 · 97232 Giebelstadt · Germany · Tel. +49 9334 942-0 · Fax +49 9334 942-1160
www.bavaria-yachtbau.com · info@bavaria-yachtbau.com

Some of the yachts shown here are equipped with optional extras which are available at an additional cost. Some details are based on design drawings and the final execution may differ.
This catalogue is not part of a contract. All descriptions, photos, etc. are for illustration purposes only.

