

# RF and IF amplifiers with op amps

By **Bruce Carter** (Email: r-carter5@ti.com)

Advanced Linear Products, Op Amp Applications

## Introduction

Why use op amps for RF design? Traditional RF design techniques using discrete transistors have been practiced successfully for decades. RF designers who are comfortable with things “as is” will scrutinize introduction of a new design technique using op amps. For high-performance RF equipment, however, high-speed op amps have some distinct advantages:

- When discrete transistors are used, the bias and operating points of the transistors interact with the gain and tuning of the stage. With op amps, the bias point is independent of gain and tuning.
- Op amp stages can operate over wide ranges of frequencies because there are no inductors to take into account.
- Transistor parameter drift and beta variation must also be taken into account over the system operating temperature range. When op amps are used, the drift is almost eliminated because gain is determined in stable passive components.

So what type of circuits can realistically be implemented with op amps? The remainder of this article describes wideband RF and narrow-band IF amplifiers.

## Choosing the op amp

There is a decision to be made when selecting op amps for RF applications—whether to use voltage- or current-feedback amplifiers. Most analog interface designers are very familiar with voltage-feedback op amps but are needlessly apprehensive about current feedback. RF designers, being relatively new to op amps, probably have no such reservations. Voltage-feedback amplifiers, although a mature technology that is rapidly increasing in speed, still have a significant limitation of gain versus bandwidth imposed by their internal compensation capacitors. This limits their use in RF circuits to high-gain, relatively low-frequency circuits.

Current-feedback amplifiers are often pitched as having no limitation of gain versus bandwidth. Supposedly they are usable to almost their specified  $-3$ -dB frequency at just about any gain. This is only partially true. While there is no “ $-20$  per decade” slope to their gain/bandwidth curve, they most definitely are bandwidth-limited at higher gains. Internal parasitics do take a toll on the bandwidth! The stability of current-feedback amplifiers is determined solely by their feedback resistor value. This value, or narrow range of values, is often fairly low—a few hundred ohms at most. This makes the useful gain range fairly low—a voltage gain of 10 or 12 in a single stage.

## Wideband RF amplifiers

For wideband RF amplifiers, current-feedback amplifiers are the components of choice. As an example, the THS3202 in Figure 1 was chosen for its wide bandwidth and fast slew

rate. The circuit shown was used to produce an amplifier voltage gain of 20 and a stage voltage gain of 10.

Note the simplicity of this circuit compared to traditional RF circuitry. Provide the op amp, the termination and decoupling components, and two resistors—and the circuit is done! The  $301\text{-}\Omega$  ( $R_F$ ) and  $16.5\text{-}\Omega$  ( $R_G$ ) resistors are all that are required to set the stage gain. This circuit produces the amplitude curve in Figure 2.

Figure 1. Wideband RF amplifier

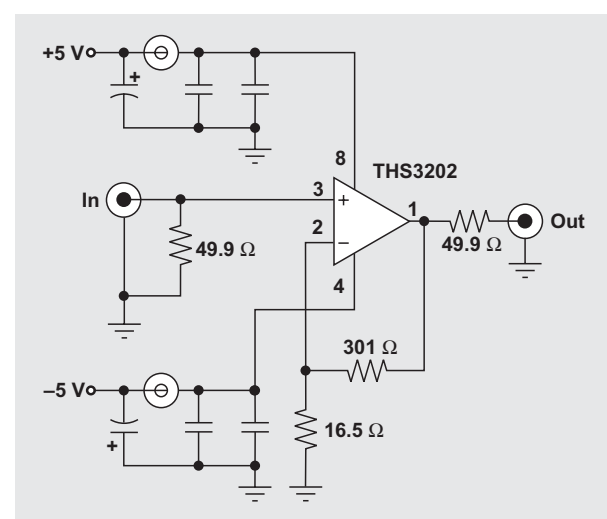

Figure 2. Wideband response for circuit in Figure 1

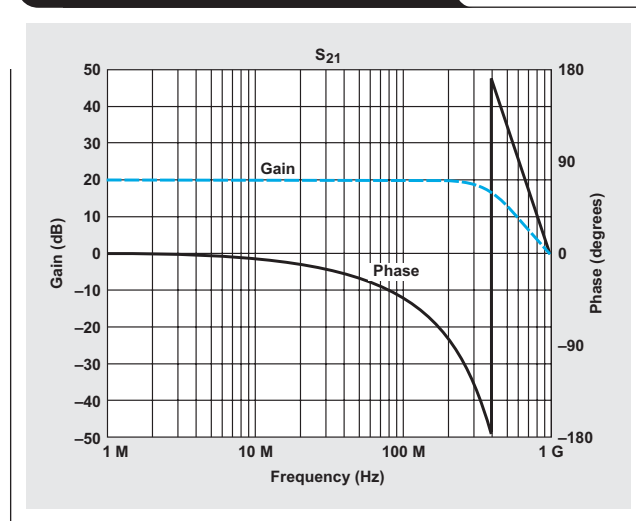
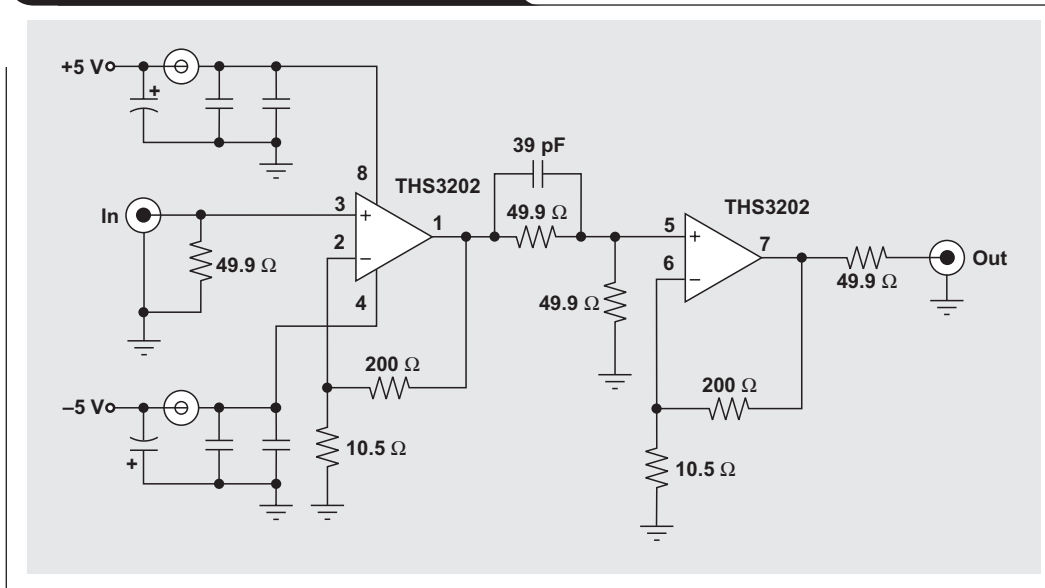

Figure 3. 40-dB wideband RF amplifier



The voltage gain of the op amp stage itself is 20, but this is cut in half by the action of the back termination resistor in combination with the load. The  $-3$ -dB point of the RF amplifier is about 390 MHz. If a flat gain over frequency is required, this circuit is only usable to about 200 MHz. Input and output VSWR values are better than 1.01:1 for most of the bandwidth, degrading to only about 1.1:1 near 200 MHz.  $S_{12}$  is  $-75$  dB over most of the bandwidth, degrading to only  $-50$  dB near the bandwidth limit.

One might wonder if more gain could be coaxed from the stage by lowering the gain resistor ( $R_G$ ) even more. The answer is yes, but there is a practical limit. Remember that the feedback resistor ( $R_F$ ) is the determining factor for current-feedback amplifier stability. Remember also that  $R_G$  has to drop proportionally more. One can see that it would not be long until the value of  $R_G$  became impractically small. Lab tests were attempted with various values of  $R_F$ . The result was that there is no advantage to making it smaller than  $200 \Omega$ . Below that, peaking starts to occur regardless of the value of  $R_G$ , becoming worse and worse as the resistance is made lower and lower. This is exactly what one would expect, because one thing to avoid in working with current-feedback amplifiers is to make  $R_F$  a short.

More gain requires cascading multiple stages of THS3202 op amps. Fortunately for the designer, the THS3202 is a dual device, making a two-stage RF amplifier easy to implement at very little additional cost.

The circuit in Figure 3 shows such a cascaded RF amplifier, used to create a voltage gain of 100 (40 dB).

This circuit requires little explanation. It is obviously composed of two identical gain stages. Isolation is accomplished by using interstage termination resistors. The 39-pF capacitor provides peaking to compensate for some high-frequency roll-off, but better IP3 performance can be achieved by removing it and living with the roll-off. Overall circuit response is shown in Figure 4.

The reader will note that the stage is usable to 100 MHz, but there is significant peaking outside of that range. It is

assumed that an amplifier of this high gain will be adequately shielded, and that there will be passive filtering components used to eliminate any problems from out-of-band response. Other S parameters for this circuit are similar to the case of the single op amp.

But what about voltage-feedback amplifiers? Is there any “niche” where they are more suitable than current-feedback amplifiers? There may be one. The stability of a voltage-feedback amplifier is primarily a function of its feedback and gain resistor ratio. Therefore, the designer is not constrained in the selection of a feedback resistor. Selecting a low-value feedback resistor can maximize the speed of the device; indeed, most data sheets recommend low feedback-resistor values. Making the resistor larger, however, does not adversely affect the stability of the

Figure 4. 40-dB RF amplifier response

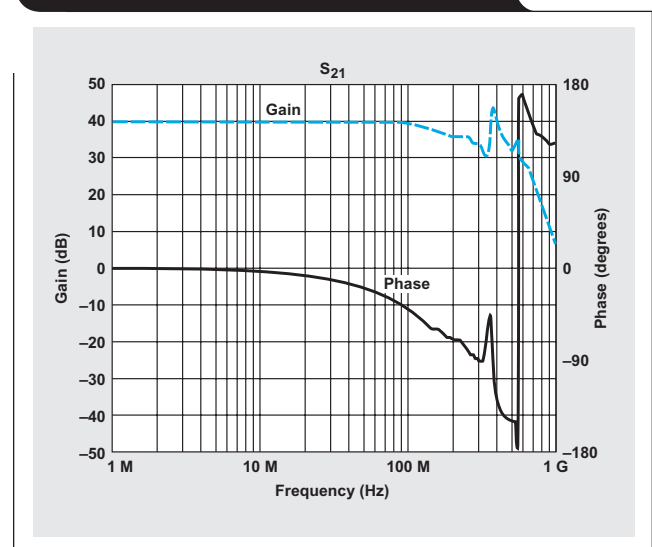

amplifier. This means that large resistor ratios are possible without making  $R_G$  a very low value.

Figure 5 shows the response of a 40-dB RF amplifier constructed from a THS4271. Most notable is the bandwidth limitation; this amplifier is usable to only about 1 MHz. This might be valuable for medium-wave applications, but nothing higher in frequency. Yet the stage was constructed from a single op amp, with an  $R_F$  of 10 k $\Omega$  and an  $R_G$  of 49.9  $\Omega$  (that just happens to match the standard termination value). This gives a non-inverting gain of 201, but this gain is divided in two by the back termination resistor and the monitoring instrument. The freedom to use 10 k $\Omega$  as  $R_F$  allows  $R_G$  to be a reasonable value. Thus a single op amp is capable of delivering 40 dB of gain, something a current-feedback amplifier cannot do. As a test, a 455-kHz intermediate-frequency (IF) amplifier was constructed that had 37 dB of gain with a single op amp.

Therefore, there is a range of applications at relatively low frequencies and higher gains that are the exclusive domain of voltage-feedback amplifiers.

### Intermediate-frequency (IF) amplifiers

The gain circuit shown in Figure 3 can easily be cascaded with ceramic filters and surface acoustic wave (SAW) filters to form high-performance IF stages. The only design consideration is the insertion loss of the filter, which may not be a constant value from part to part or from batch of parts to batch of parts, etc. If precise gain is needed from the stage, the designer may need to include a trim resistor in one or both stages. This trim adjustment, however, will not affect the tuning of the stage, except for a slight effect on its upper frequency limit.

Figure 5. RF amplifier using THS4271

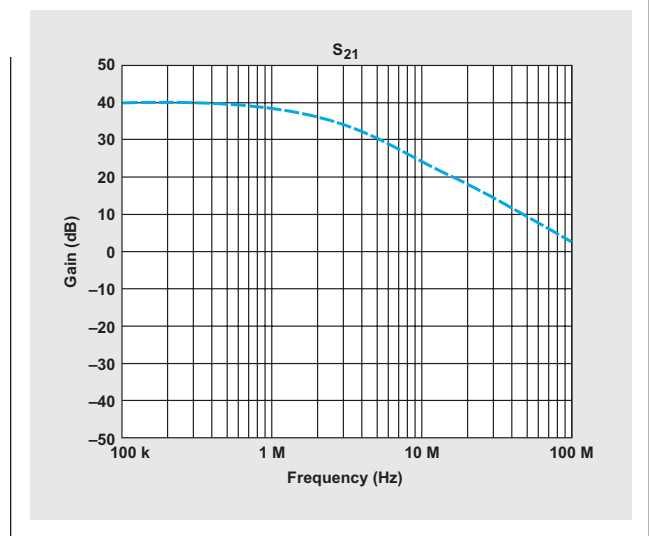

### 10.7-MHz IF amplifier

There is widespread use of 10.7-MHz IF amplifiers in FM broadcast receivers and cell phone base station receivers (final IF). These products make use of inexpensive ceramic filters, which are available in a variety of bandwidths and insertion losses. The circuit shown in Figure 6 was constructed with the gain stage shown in Figure 3 and a 230-kHz bandwidth filter from Murata, the

Figure 6. 10.7-MHz IF amplifier

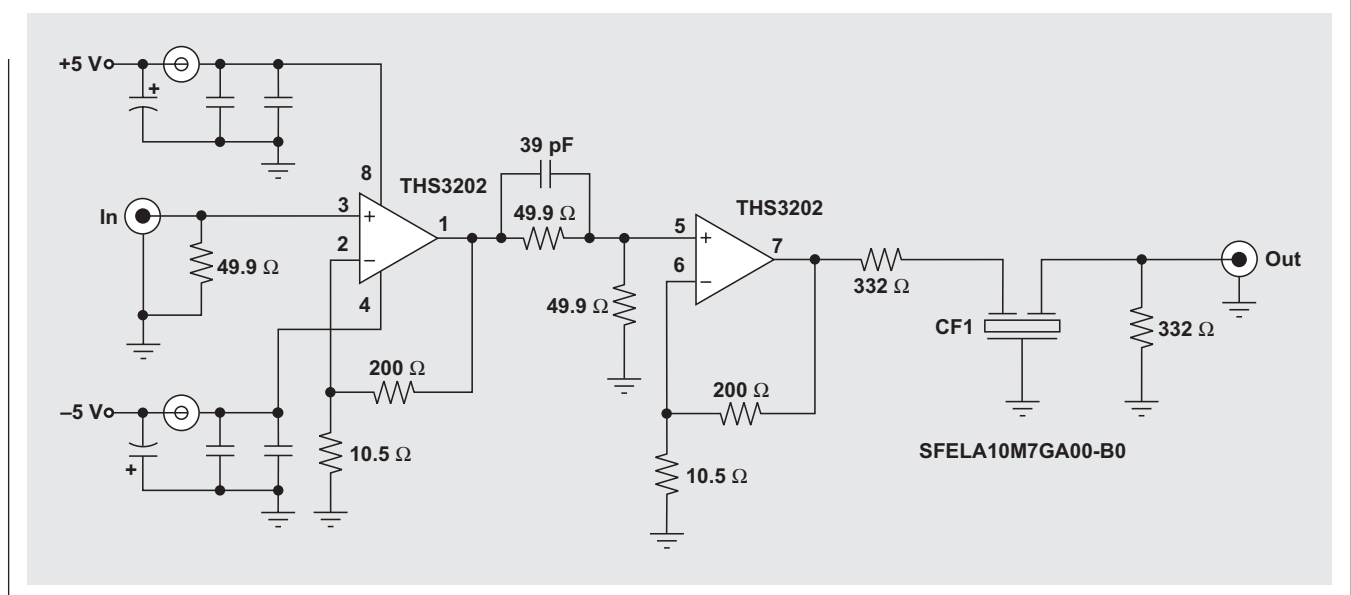

SFELA10M7GA00-B0. This filter has a nominal insertion loss of 4 dB, and the circuit response is shown in Figure 7.

The slight nonlinearity in the passband has more to do with the characteristics of the ceramic filter than it does with the op amp. Insertion loss is slightly more than 4 dB. This response has been corrected for the impedances of the circuit, which are different from a nominal load of 50 Ω. The response was actually measured with a 280-Ω resistor in series with the 50-Ω instrument as the load. That made a voltage divider, the effects of which have been compensated for in the figure.

**70-MHz IF amplifier**

Cellular telephone base stations and satellite communications receivers use 70-MHz IF amplifiers. At these frequencies, SAW filters are used. For our example, an 854660 filter from Sawtek was selected. This unit requires input and output inductors, and operates with standard 50-Ω input and output. Sawtek conveniently provided an EVM board, which greatly simplified prototyping. The circuit shown in Figure 8 produces the 70-MHz response shown in Figure 9.

**Figure 7. Response of 10.7-MHz IF amplifier**

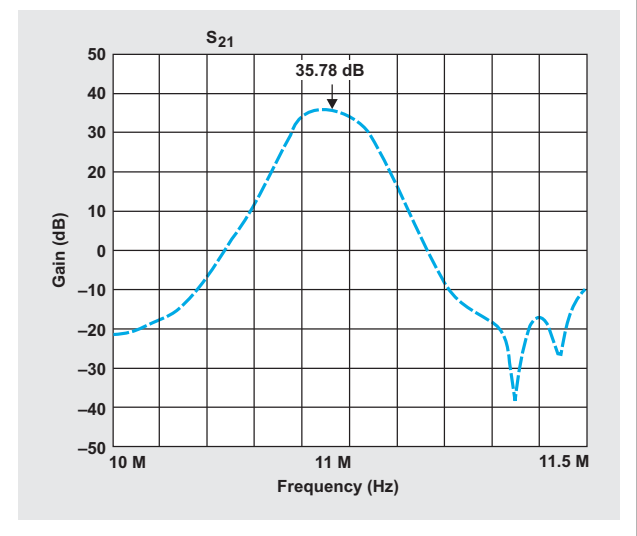

**Figure 8. 70-/140-MHz IF amplifier**

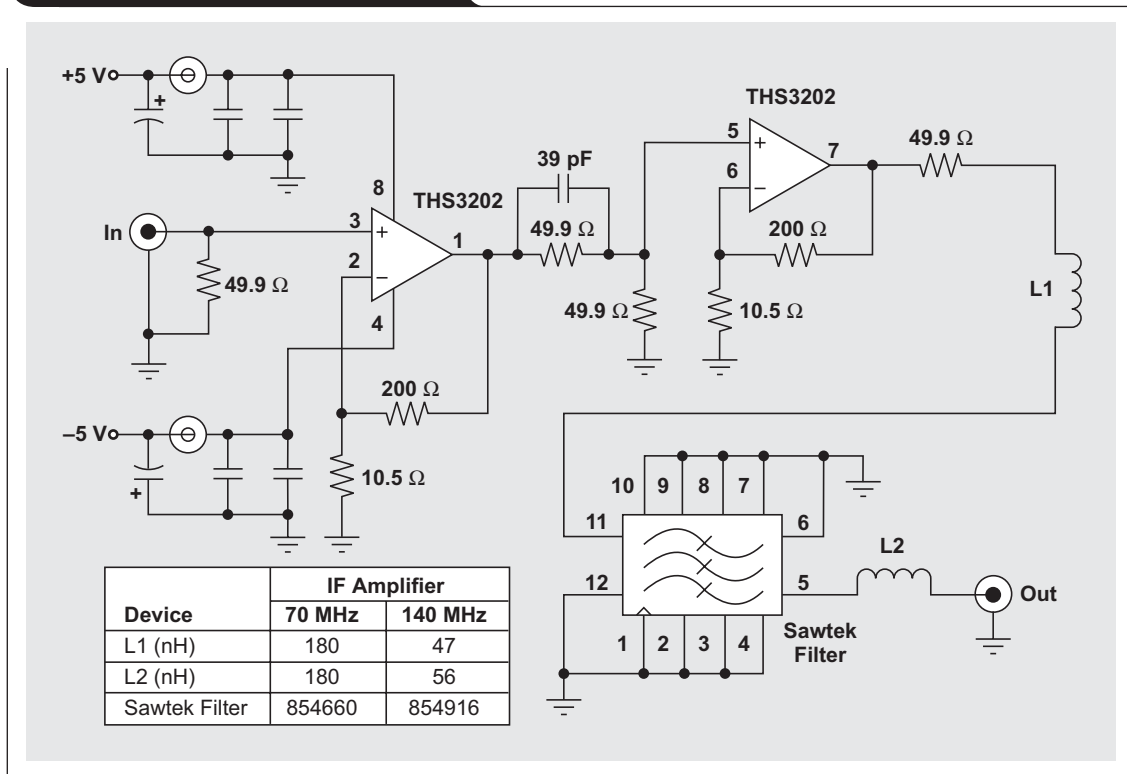

The response curve in Figure 9 is almost identical in shape to the curve of the Sawtek filter itself. In other words, the amplifier is providing gain, while not adding undesirable harmonic content. The insertion loss of the SAW filter is about 7 dB.

### 140-MHz IF amplifier

Cellular telephone base stations also use 140-MHz IF amplifiers. For our example, an 854916 filter from Sawtek was selected along with smaller inductors, as shown in Figure 8. The circuit response is shown in Figure 10.

As was the case for the 70-MHz IF filter, the response curve in Figure 10 is almost identical in shape to the curve of the Sawtek filter itself. Again, the amplifier is providing gain, while not adding undesirable harmonic content. The insertion loss of the SAW filter is only 8 dB maximum; but the gain circuit itself is starting to roll off at this frequency, accounting for the rest of the loss. Careful examination of the passband shows the slight roll-off of the gain stage.

### Conclusion

Although inexpensive RF design continues to be the exclusive domain of transistors, there is a class of RF applications where performance—not cost—is the driving factor. These applications stand to benefit tremendously from the excellent RF performance that op amps can provide. By freeing the designer from the interrelated tasks of calculating biasing and gain, decoupling, and peaking, op amps also simplify RF design, even for novices. Troublesome components such as inductors and variable peaking capacitors are eliminated, and circuit gain depends on relatively stable resistors instead of the widely variable parameters of transistors. This makes RF design with op amps repeatable in production and eliminates trimming and aligning test stations when the product is manufactured. Maintenance of the equipment, therefore, is also simplified; no periodic adjustments are needed to maintain top levels of performance.

### Related Web sites

[analog.ti.com](http://analog.ti.com)

[www.ti.com/sc/device/THS3202](http://www.ti.com/sc/device/THS3202)

[www.ti.com/sc/device/THS4271](http://www.ti.com/sc/device/THS4271)

Figure 9. Response of 70-MHz amplifier

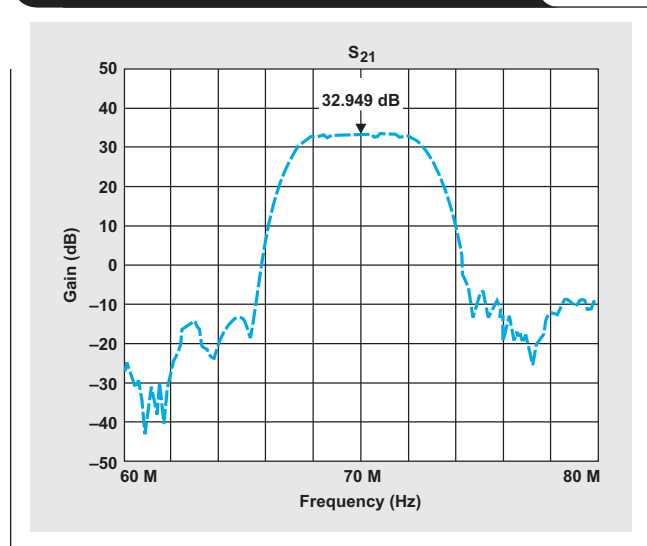
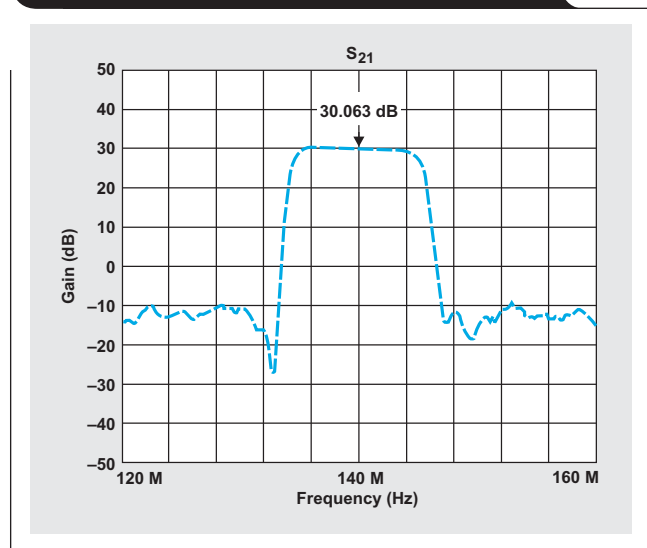

Figure 10. Response of 140-MHz amplifier



## IMPORTANT NOTICE

Texas Instruments Incorporated and its subsidiaries (TI) reserve the right to make corrections, modifications, enhancements, improvements, and other changes to its products and services at any time and to discontinue any product or service without notice. Customers should obtain the latest relevant information before placing orders and should verify that such information is current and complete. All products are sold subject to TI's terms and conditions of sale supplied at the time of order acknowledgment.

TI warrants performance of its hardware products to the specifications applicable at the time of sale in accordance with TI's standard warranty. Testing and other quality control techniques are used to the extent TI deems necessary to support this warranty. Except where mandated by government requirements, testing of all parameters of each product is not necessarily performed.

TI assumes no liability for applications assistance or customer product design. Customers are responsible for their products and applications using TI components. To minimize the risks associated with customer products and applications, customers should provide adequate design and operating safeguards.

TI does not warrant or represent that any license, either express or implied, is granted under any TI patent right, copyright, mask work right, or other TI intellectual property right relating to any combination, machine, or process in which TI products or services are used. Information published by TI regarding third-party products or services does not constitute a license from TI to use such products or services or a warranty or endorsement thereof. Use of such information may require a license from a third party under the patents or other intellectual property of the third party, or a license from TI under the patents or other intellectual property of TI.

Reproduction of information in TI data books or data sheets is permissible only if reproduction is without alteration and is accompanied by all associated warranties, conditions, limitations, and notices. Reproduction of this information with alteration is an unfair and deceptive business practice. TI is not responsible or liable for such altered documentation.

Resale of TI products or services with statements different from or beyond the parameters stated by TI for that product or service voids all express and any implied warranties for the associated TI product or service and is an unfair and deceptive business practice. TI is not responsible or liable for any such statements.

Following are URLs where you can obtain information on other Texas Instruments products and application solutions:

### Products

Amplifiers	<a href="http://amplifier.ti.com">amplifier.ti.com</a>
Data Converters	<a href="http://dataconverter.ti.com">dataconverter.ti.com</a>
DSP	<a href="http://dsp.ti.com">dsp.ti.com</a>
Interface	<a href="http://interface.ti.com">interface.ti.com</a>
Logic	<a href="http://logic.ti.com">logic.ti.com</a>
Power Mgmt	<a href="http://power.ti.com">power.ti.com</a>
Microcontrollers	<a href="http://microcontroller.ti.com">microcontroller.ti.com</a>

### Applications

Audio	<a href="http://www.ti.com/audio">www.ti.com/audio</a>
Automotive	<a href="http://www.ti.com/automotive">www.ti.com/automotive</a>
Broadband	<a href="http://www.ti.com/broadband">www.ti.com/broadband</a>
Digital control	<a href="http://www.ti.com/digitalcontrol">www.ti.com/digitalcontrol</a>
Military	<a href="http://www.ti.com/military">www.ti.com/military</a>
Optical Networking	<a href="http://www.ti.com/opticalnetwork">www.ti.com/opticalnetwork</a>
Security	<a href="http://www.ti.com/security">www.ti.com/security</a>
Telephony	<a href="http://www.ti.com/telephony">www.ti.com/telephony</a>
Video & Imaging	<a href="http://www.ti.com/video">www.ti.com/video</a>
Wireless	<a href="http://www.ti.com/wireless">www.ti.com/wireless</a>

## TI Worldwide Technical Support

### Internet

**TI Semiconductor Product Information Center Home Page**  
[support.ti.com](http://support.ti.com)

**TI Semiconductor KnowledgeBase Home Page**  
[support.ti.com/sc/knowledgebase](http://support.ti.com/sc/knowledgebase)

### Product Information Centers

#### Americas

Phone	+1(972) 644-5580	Fax	+1(972) 927-6377
Internet/Email	<a href="http://support.ti.com/sc/pic/americas.htm">support.ti.com/sc/pic/americas.htm</a>		

#### Europe, Middle East, and Africa

Phone			
Belgium (English)	+32 (0) 27 45 54 32	Netherlands (English)	+31 (0) 546 87 95 45
Finland (English)	+358 (0) 9 25173948	Russia	+7 (0) 95 7850415
France	+33 (0) 1 30 70 11 64	Spain	+34 902 35 40 28
Germany	+49 (0) 8161 80 33 11	Sweden (English)	+46 (0) 8587 555 22
Israel (English)	1800 949 0107	United Kingdom	+44 (0) 1604 66 33 99
Italy	800 79 11 37		
Fax	+(49) (0) 8161 80 2045		
Internet	<a href="http://support.ti.com/sc/pic/euro.htm">support.ti.com/sc/pic/euro.htm</a>		

#### Japan

Fax			
International	+81-3-3344-5317	Domestic	0120-81-0036
Internet/Email			
International	<a href="http://support.ti.com/sc/pic/japan.htm">support.ti.com/sc/pic/japan.htm</a>		
Domestic	<a href="http://www.tij.co.jp/pic">www.tij.co.jp/pic</a>		

#### Asia

Phone			
International	+886-2-23786800		
Domestic	Toll-Free Number		
Australia	1-800-999-084	New Zealand	0800-446-934
China	800-820-8682	Philippines	1-800-765-7404
Hong Kong	800-96-5941	Singapore	800-886-1028
Indonesia	001-803-8861-1006	Taiwan	0800-006800
Korea	080-551-2804	Thailand	001-800-886-0010
Malaysia	1-800-80-3973		
Fax	886-2-2378-6808	Email	<a href="mailto:tiasia@ti.com">tiasia@ti.com</a>
Internet	<a href="http://support.ti.com/sc/pic/asia.htm">support.ti.com/sc/pic/asia.htm</a>		<a href="mailto:ti-china@ti.com">ti-china@ti.com</a>

**C011905**

**Safe Harbor Statement:** This publication may contain forward-looking statements that involve a number of risks and uncertainties. These "forward-looking statements" are intended to qualify for the safe harbor from liability established by the Private Securities Litigation Reform Act of 1995. These forward-looking statements generally can be identified by phrases such as "TI or its management believes," "expects," "anticipates," "foresees," "forecasts," "estimates" or other words or phrases of similar import. Similarly, such statements herein that describe the company's products, business strategy, outlook, objectives, plans, intentions or goals also are forward-looking statements. All such forward-looking statements are subject to certain risks and uncertainties that could cause actual results to differ materially from those in forward-looking statements. Please refer to TI's most recent Form 10-K for more information on the risks and uncertainties that could materially affect future results of operations. We disclaim any intention or obligation to update any forward-looking statements as a result of developments occurring after the date of this publication.

**Trademarks:** All trademarks are the property of their respective owners.

Mailing Address: Texas Instruments  
Post Office Box 655303  
Dallas, Texas 75265

© 2005 Texas Instruments Incorporated