Subsurface Science

H. Levine
G. MacDonald
O. Rothaus
M. Ruderman
S. Treiman
E. Williams

In collaboration with:

J. Banfield
R. Colwell
B. Ensley
D. Galas

July 1995

JSR-94-330

Accession For	
NTIS CRA&I	<input checked="" type="checkbox"/>
DTIC TAB	<input type="checkbox"/>
Unannounced	<input type="checkbox"/>
Justification	
By	
Distribution /	
Availability Codes	
Dist	Avail and/or Special
A-1	

Approved for public release; distribution unlimited.

JASON
The MITRE Corporation
7525 Colshire Drive
McLean, Virginia 22102-3481
(703) 883-6997

REPORT DOCUMENTATION PAGE

Form Approved
OMB No. 0704-0188

Public reporting burden for this collection of information estimated to average 1 hour per response, including the time for review instructions, searching existing data sources, gathering and maintaining the data needed, and completing and reviewing the collection of information. Send comments regarding this burden estimate or any other aspect of this collection of information, including suggestions for reducing this burden, to Washington Headquarters Services, Directorate for Information Operations and Reports, 1215 Jefferson Davis Highway, Suite 1204, Arlington, VA 22202-4302, and to the Office of Management and Budget, Paperwork Reduction Project (0704-0188), Washington, DC 20503.

1. AGENCY USE ONLY (<i>Leave blank</i>)		2. REPORT DATE July 25, 1995	3. REPORT TYPE AND DATES COVERED	
4. TITLE AND SUBTITLE SUBSURFACE SCIENCE			5. FUNDING NUMBERS 04-958534-01	
6. AUTHOR(S) H. Levine, G. MacDonald, O. Rothaus, M. Ruderman, S. Treiman, E. Williams. In collaboration with: J. Banfield, R. Colwell, B. Ensley, D. Galas				
7. PERFORMING ORGANIZATION NAME(S) AND ADDRESS(ES) The MITRE Corporation JASON Program Office 7525 Colshire Drive McLean Virginia 22102			8. PERFORMING ORGANIZATION REPORT NUMBER JSR-94-330	
9. SPONSORING/MONITORING AGENCY NAME(S) AND ADDRESS(ES) US Department of Energy ER/30 OER Washington, DC 20585-1290			10. SPONSORING/MONITORING AGENCY REPORT NUMBER JSR-94-330	
11. SUPPLEMENTARY NOTES				
12a. DISTRIBUTION/AVAILABILITY STATEMENT Approved for public release; distribution unlimited.			12b. DISTRIBUTION CODE	
13. ABSTRACT (<i>Maximum 200 words</i>) Use of bacteria in subsurface remediation shows great promise. A number of technical problems in the use of bacteria require further investigation. The physics and chemistry of the movement of bacteria in the heterogenous subsurface is poorly understood. A novel concept that needs further work is to use resident microorganisms and to transmit only the new genetic instructions from the surface.				
14. SUBJECT TERMS bacteria, remediation, subsurface, microorganisms			15. NUMBER OF PAGES	
			16. PRICE CODE	
17. SECURITY CLASSIFICATION OF REPORT Unclassified	18. SECURITY CLASSIFICATION OF THIS PAGE Unclassified	19. SECURITY CLASSIFICATION OF ABSTRACT Unclassified	20. LIMITATION OF ABSTRACT SAR	

Contents

1	INTRODUCTION	1
2	SUBSURFACE SCIENCE PROGRAM OVERVIEW	5
3	ATTACHMENT OF BACTERIA TO WALLS	9
3.1	Introduction	9
3.2	Physical Basis of Cell-Wall Interactions	10
3.2.1	Electrostatic Interactions	10
3.2.2	van der Waals Forces	18
3.2.3	Wall-Cell Attraction at Large Separations	27
3.3	Assessment of the Energetics and Kinetics of Adhesion	32
3.4	Flow Induced Force on Wall-Attached Bacteria	41
3.5	Conclusions and Recommendations	46
4	TRANSPORT OF BACTERIA THROUGH POROUS MEDIA	47
5	METAL BIOPROCESSING	65
6	IN SITU RECOMBINANT DNA	69
7	THE STATISTICS OF CENSUS TAKING	73
8	NUCLEAR WASTE DISPOSAL—BOROSILICATE GLASS	75
8.1	Introduction	75
8.2	The Problem	76
8.3	Borosilicate Glass Waste Loading	77
8.4	Processability	78
8.5	Durability	79
8.6	Alternatives and Future Developments	80
9	ENVIRONMENTAL AND MOLECULAR SCIENCES LABORATORY (EMSL)	83
9.1	Recommendations for EMSL	85
9.2	Advanced Processing	88
9.3	Environmental Dynamics and Simulation	89

9.4	Theory, Modeling and Simulation	89
9.5	Materials and Interfaces	90
9.6	Chemical Structures and Dynamics	91
9.7	Macromolecular Structure and Dynamics	92
10	BIOREMEDIATION	93
10.1	The Long Haul	93

1 INTRODUCTION

The United States Department of Energy (DOE) in 1985 established the Subsurface Science Program. The primary purpose of this program is to assist DOE's efforts to clean up wastes that have been disposed of underground and that have moved from surface sites into the underground. While the mining and petroleum companies have carried out extensive operations in the subsurface, the physics, chemistry, and particularly, the biology of the subsurface environment are largely unknown.

In Section 2, we present our overall view of the program, its major goals, and outstanding issues. In general, this is a high-quality program, and deserves continuing and increasing support. The problem of understanding the subsurface environment in such a way as to make bioremediation a useful alternative is highly challenging. The subsurface environment is characterized by great natural physical and biological heterogeneity. This heterogeneity is discussed in Sections 2, 3, and 6. The complexity of natural heterogeneity is a theme running throughout the report. Methods to describe the heterogeneity in a useful way must be developed.

The questions raised in Section 2 attempt to frame the goals of a subsurface program. These goals should include understanding:

- subsurface movement
- subsurface microbial structure

- in situ behavior of subsurface microbes
- origins of subsurface microbial organisms.

In pursuing these objectives, there should be a balance between technique development and field studies.

Of the various issues facing the Subsurface Program, we have selected one—the transport of bacteria underground—for a more detailed technical treatment. Section 3 deals with the physics of attachment of bacteria to walls, while Section 4 considers the problems in understanding transport of bacteria through porous media. In selecting these problems, we recognize that we do not yet know how bacteria function in the subsurface, whether in situ or planktonic (free).

Section 5 provides a brief introduction to bioprocessing of metals. The subject has a vast literature, and therefore we only present an overview.

In Section 6, we consider the issue of transmitting genetic information to resident bacteria. We also discuss the possibility of using viruses (phage) and/or liposomes to provide the genetic information to resident bacteria so as to give them the desired properties. Section 2 comments on the validity of sampling the subsurface.

Section 8 departs from the main theme of the report. In this section, we briefly consider the difficult issue of nuclear waste disposal. The reason for doing so is to emphasize that alternatives to borosilicate glass exist, and that these alternatives should not be forgotten, particularly because long-term disposal has been greatly delayed.

In Section 9, we comment on the new Environmental Molecular Science Laboratory (EMSL). We believe that this new laboratory can be one of DOE's centers supporting subsurface science. It is clearly important that the EMSL have microbiological/molecular biological/biochemical expertise in residence. However, we are concerned that the Laboratory's mission is not well defined.

In the final section, we briefly consider the long-term future of bioremediation. A science in its infancy probably should not go into the field, but the future of bioremediation as an option depends on field investigation. There thus needs to be the balance discussed above between field work, laboratory investigation, and methods development.

The report does not pretend to be a comprehensive overview of the entire Subsurface Program. For example, we say nothing about ongoing work on issues related to mixed contaminants. What we have tried to do is provide an introduction to some important elements of the program, and to discuss some ways in which the program could be improved.

2 SUBSURFACE SCIENCE PROGRAM OVERVIEW

In general, the Department of Energy (DOE) Subsurface Science Program (SSP) is an excellent one of high scientific quality. It is unique in the degree to which the various disciplines have been brought together, and in the integration of field and laboratory programs. In many ways, it is an outstanding paradigm for future programs that must integrate basic and applied sciences from several disciplines in the service of highly practical goals.

The critical issue for the future of the program is to have a clearly articulated goal. This goal can then be used to judge the relevance of various scientific activities. Since the subsurface, and in particular subsurface ecology, is such an unexplored frontier, there may be a tendency to pursue approaches of high scientific interest that do not necessarily contribute to the overall goal of the program. Our understanding of the long-term practical goal of the program is to enable and enhance the capability of the United States to diagnose, understand, and carry out effective and economically feasible subsurface remediation. In furthering this goal, there is a real need to answer a number of open scientific questions. While we do not claim completeness, the following questions appear to have major significance for reaching the overall practical goal.

1. How can we acquire a fundamental (predictive) understanding of the movement of fluids, chemicals, and colloids (including biological) in complex subsurface media? It is clear that our present ability to predict subsurface movement is minimal at best. A major part of this is

physics and chemistry, but a significant section is biological. The biological component of subsurface flow is largely unexplored. Elsewhere in this report we present a technical discussion of the movement of microorganisms in the subsurface environment.

2. What microorganisms are present in the subsurface? An understanding of the microbiology census of the subsurface would seem to be a prerequisite to the understanding of what microorganisms do, and are capable of doing, to the subsurface environment. Since the rock structures of the subsurface environment are highly heterogeneous and anisotropic, there are difficult problems of how to construct a statistically sensible sampling strategy. Conventional statistics are probably inadequate to characterize the subsurface environment in a meaningful way. Explicit account must be taken both of the anisotropy of the subsurface and of the fact that variations at virtually all scales are present.
3. How do known microorganisms, much less unknown species, behave in the subsurface environment? What chemical transformations do they accomplish, under what conditions, and what past modifications of the environment are attributable to these bacterial populations? All of these questions concern scientific uncertainties that are central to the program.
4. What are the origins of the subsurface microorganisms? Have they developed in place, or have they been carried from the near-surface layer to the deep subsurface? To what extent have they evolved in their present state? What do these subsurface microorganisms tell us about the origin of life?

Given that a large part of the significant scientific uncertainty concerns the biological component of the subsurface, and given that the success of the program depends on reducing this uncertainty, it makes sense that a significant effort be devoted to the biological components of the program. In particular, a much more concerted effort should be developed to adopt, develop, and utilize modern molecular biological methods for the subsurface program. For example, methods such as those developed by David White of the University of Tennessee to characterize the signature lipid compounds made by various organisms, and complementary DNA-based methods, could significantly increase the sensitivity of detection and the density of information obtained about subsurface organisms. The polymerase chain reaction method (PCR), for instance, has been shown to be capable of amplifying, detecting, and identifying a single DNA molecule, which translates to a single bacterial cell if its DNA is accessible. PCR is routinely used on marine microbial samples. It has also been used on in situ biological samples of various kinds, such as fixed tissue sections. It should be possible, with little overall effort, to develop the techniques for using PCR effectively and inexpensively on subsurface samples. This would change dramatically what could be obtained from the field samples. While the program is already devoting some effort to the development of these techniques for using DNA-based methods (DNA probe methods, for example), they should be a priority of the program. The methods are increasingly versatile and powerful for characterizing biological organisms. Only with such methods can the field programs gain their full effectiveness and cost efficiency in knowledge gained for dollars spent.

Thus, there should be a better balance between the development and use of new laboratory techniques adaptable to the field and the field studies component of the program. It will also be necessary to perform more

biochemical and genetic characterization of subsurface organisms as part of the program in order fully to realize the potential gain of useful knowledge. These studies should include some selective sequencing of novel organisms' genomes and some biochemical physiology of the bacteria, to include studies of the control mechanisms for gene expression operative in the subsurface. This latter is too ambitious a goal for the program to approach on a broad front, but selective efforts and a concerted effort to open the lines of communication and collaboration of the program with other microbiologists working on such problems should be a priority. The geologic component of the program and the origin of subsurface bacteria effort are exciting scientifically, generally well conceived, and should lead to major modifications of our insight into the origin of subsurface microorganisms. This insight is likely to have a significant practical outcome.

3 ATTACHMENT OF BACTERIA TO WALLS

3.1 Introduction

Toxic waste that has had long times to percolate through the subsurface presents major problems for any type of clean-up effort. In bioremediation, the transport of bacteria to the subsurface sites of the waste and insurance of bacterial activity once on-site are both major issues. The nature of bacterial adhesion to surfaces is a major factor in both of these problems, and adhesive properties thus will be an important criterion in selecting and/or bio-engineering bacteria for subsurface waste degradation.

The evaluation of how bacterial adhesive properties will affect function in biodegradation is a difficult problem due to the many length scales of heterogeneity involved. Bacterial surfaces themselves have complex and heterogeneous structures [1] [2], so that the simple physical model [1] [3] generally used to describe their temporal adhesive behavior has limited predictive capability. In addition, the process of bacterial adhesion is likely to be temporally heterogeneous, as the bacteria respond biologically to changes in their environment. Finally, the mineral walls with which the bacteria interact below ground are highly heterogeneous, both chemically and in terms of roughness, on lengths ranging from the atomic to the macroscopic.

The DOE Subsurface Science Program is addressing many of these issues through a broad-based program including microbiological analyses of indigenous bacteria, laboratory studies of adhesion, field studies of geologi-

cal sites, and field and laboratory studies of transport in mixed media. The results of all of these efforts need to be coordinated in order to establish a successful bioremediation effort.

In the following, we will review some of the basic factors determining cell wall adhesion, and discuss what must be known about these factors for prediction of transport processes in porous media. We end with some suggestions about how the existing effort to develop successful bioremediation strategies can be strengthened.

3.2 Physical Basis of Cell-Wall Interactions

Attachment forces between a bacterium and a wall are difficult to calculate, and perhaps even estimate with confidence, from first principles. They have several origins: electrostatic interactions, van der Waals forces, polymer bridges, through covalent chemical bonding; and other forms of contact chemical bonding. The attachment can be reversible (the detached bacterium and the wall do not differ from pre-detachment ones) or irreversible (the detached bacterium leaves behind a polymer "footprint" on the wall). Present theoretical estimates for the probability and strength of bacterial attachment to walls must rely on gross oversimplifications, which can make extrapolations to new wall materials and conditions unreliable until measured.

3.2.1 Electrostatic Interactions

In water, bacteria generally have a negative surface charge and surface

potential (V_b). Similarly, mineral surfaces in contact with water (e.g., glass, clay) also acquire negatively charged surfaces and potentials (V_s). The electric field from both surfaces is screened by the positive and negative ions of the water (Debye screening), especially if it contains additional dissolved electrolytes. For weak potentials ($eV_{b,s} \ll k_bT$)

$$\nabla^2 V - \Lambda^{-2} V = 0. \quad (3-1)$$

The Debye shielding length

$$\Lambda = \left(\frac{k_b T \epsilon}{8\pi n_+ e^2} \right)^{1/2} \sim 10^4 \left(\frac{10^{14} \text{ cm}^{-3}}{n_+} \right)^{1/2} \text{ \AA}, \quad (3-2)$$

where n_+ is the number density of dissolved ion pairs and ϵ is the dielectric constant of water. For distilled water ($n_+ \sim 10^{14} \text{ cm}^{-3}$) Λ is about the same as the radii of typical bacteria; it is very much less than those radii in the cases of interest here where the electrolyte concentration is very much higher.

The "standard" model assumes that as a bacterium in water approaches a wall-water interface the potentials of both surfaces remain what they were when the bacterium was infinitely far away. Then, for an assumed spherical bacterium of radius $R(\gg \Lambda)$ with a distance of closest approach h between its surface and flat wall (Figure 3-1), the Coulomb interaction energy is [3] [4] [5]

$$E_c(h) = \frac{R\epsilon}{4} \left\{ 2V_b V_s \ln \left(\frac{\epsilon^{h/\Lambda} + 1}{\epsilon^{h/\Lambda} - 1} \right) + (V_b^2 + V_s^2) \ln(1 - \epsilon^{-2h/\Lambda}) \right\}. \quad (3-3)$$

When $h \gg \Lambda$

$$E_c(h) \cong R\epsilon V_s V_b e^{-h/\Lambda}. \quad (3-4)$$

In this regime, where only a negligible charge adjustment is needed to maintain V_s and V_b at their asymptotic values, the force between the s and b

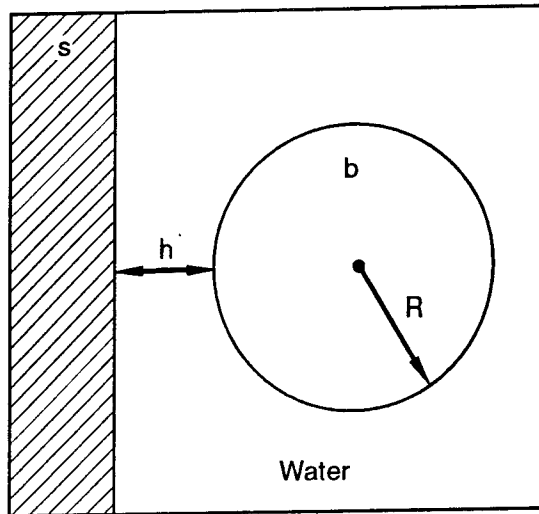

Figure 3-1. A spherical bacterium of radius R a distance h from a wall surface(s) as an idealization of a cell surface model. More realistic representations of a cell surface are shown in Figures 3-2 and 3-3.

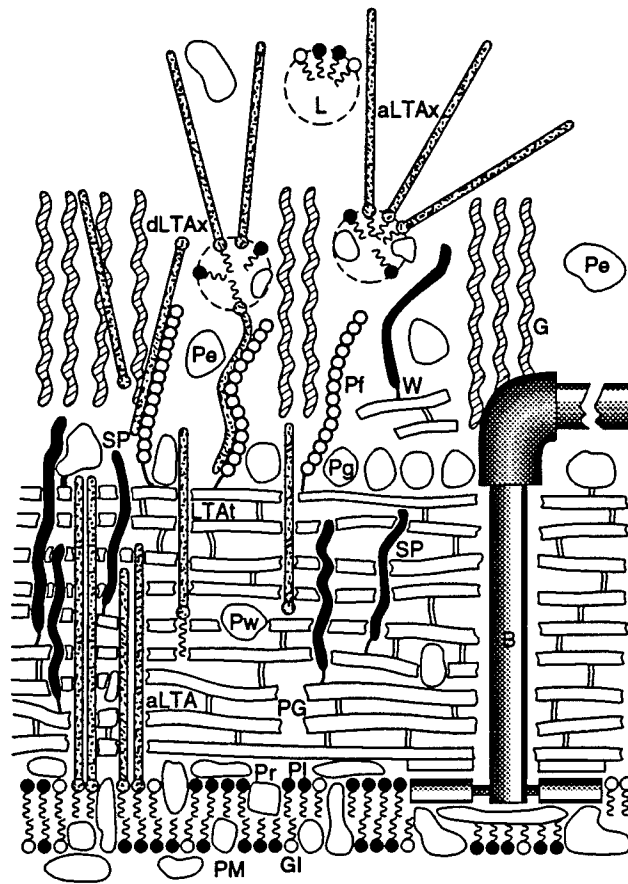

Figure 3-2. Gram-positive bacterium surface. The lettered components are explained in Reference [2].

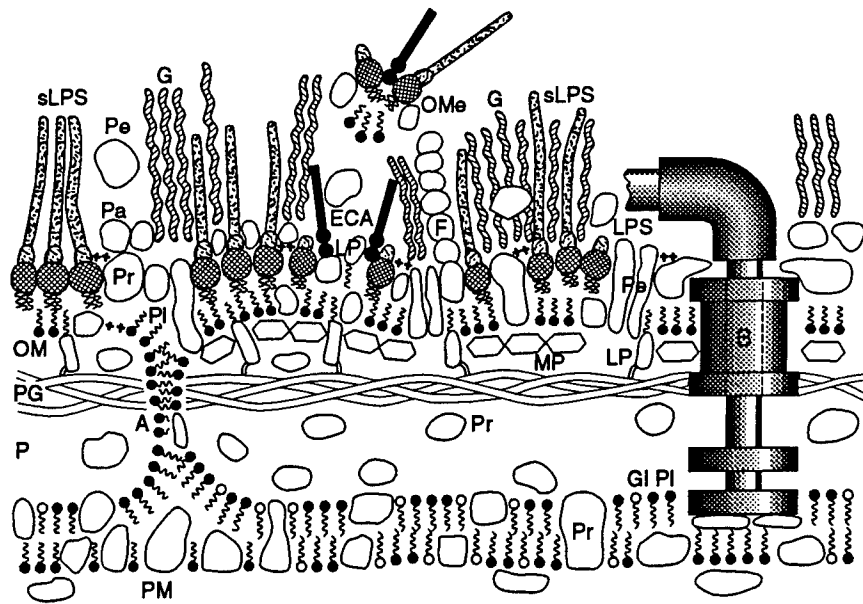

Figure 3-3. Gram-negative bacterium surface. The lettered components are explained in Reference [2].

surfaces is repulsive as long as V_s and V_b have the same sign. For $R = 10^4 \text{ \AA}$, $\epsilon = 80$, and characteristic $V_b = -25mV$, $V_s = -15mV$,

$$E_c(h) \cong 3 \cdot 10^{11} e^{-h/\Lambda} \text{ ergs} \quad (h \gg \Lambda). \quad (3-5)$$

However, when $h \ll \Lambda$ the repulsion generally changes to an attraction. In this regime

$$E_c(h) \cong \frac{R\epsilon}{4} \left\{ -(V_s - V_b)^2 \ln \frac{\Lambda}{h} + (V_s + V_b)^2 \ln 2 \right\} \quad (\Lambda \gg h). \quad (3-6)$$

As long as $V_s \neq V_b$, in the $h \rightarrow 0$ limit, where a large charge readjustment is needed to maintain the $V_{s,b}$ surface potentials, there is an attractive force between the bacterium and the wall. The maximum repulsive potential is reached for Equation (3-3) at $h = h_0$ with

$$h_0 = \Lambda \ln \left[\frac{V_b^2 + V_s^2}{2V_b V_s} \right]. \quad (3-7)$$

For the typical surface potentials which gave Equation (3-5),

$$h_0 \sim \Lambda \frac{(V_b - V_s)^2}{2V_b V_s} \sim 10^{-1} \Lambda \quad (3-8)$$

and

$$E_c(\text{max}) \equiv E_c(h_0) \sim 10^{-11} \text{ ergs}. \quad (3-9)$$

The barrier height

$$E_c(\text{max}) \gg kT \sim 5 \cdot 10^{-14} \text{ ergs} \quad (3-10)$$

for $T \sim$ room temperature. From Equation (3-5) the distance of closest approach to a wall with fixed surface potential V_s by a spherical bacterium with fixed surface potential V_b and Brownian translational kinetic energy $3 k_B T/2$ is

$$h_{\min} \cong \Lambda \ln \left(\frac{R\epsilon V_s V_b}{k_B T} \right) \sim 7\Lambda \quad (3-11)$$

if the only relevant forces are the electrostatic ones between a smooth wall and a spherically symmetric smooth-walled inert bacterium (cf. Figure 3-4). Such a bacterium would, therefore, not approach the wall closely enough to feel the attractive potential of Equations (3-6), and (3-5) would be an adequate approximation for the electrostatic part of $E(h)$.

In the above constant surface-potential model, both the wall and the bacterial surfaces are considered as conducting sheets whose potentials are fixed with respect to a distant point in the mildly conducting fluid that separates them. An alternative model makes the same assumption about the surfaces but fixes the total charge on each at its asymptotic value ($h \rightarrow \infty$) rather than the potential. In this case, Equation (3-3) is changed to [4]

$$E_c^Q(V_b, V_s; h) = E_c(V_b, -V_s; h). \quad (3-12)$$

The very short-range ($h \ll \Lambda$) attraction of Equation (3-6) now becomes a repulsion, but the long-range ($h \gg \Lambda$) repulsion of Equation (3-3) is unchanged.

Both models assume that surface charges are free to move along the bacterial and the wall surfaces and so cancel any tangential electric fields: both surfaces are described as if they were metallic. But a no less plausible model might be one in which the surface charges do not have such mobility during the short time of close approach to the h_{\min} of Equation (3-11). Instead, it could be assumed that the wall and bacterium surface charges remain fixed at their asymptotic positions. Then $E_c(h)$ would differ qualitatively from that of Equations (3-3) or (3-12) when $h \ll \Lambda$, but it is again given by Equation (3-4) when $h \gg \Lambda$.¹

¹The next term in the expansion of Equation (3-4),

$$E_2 = -(V_b^2 + V_s^2)e^{-\frac{2h}{\Lambda}},$$

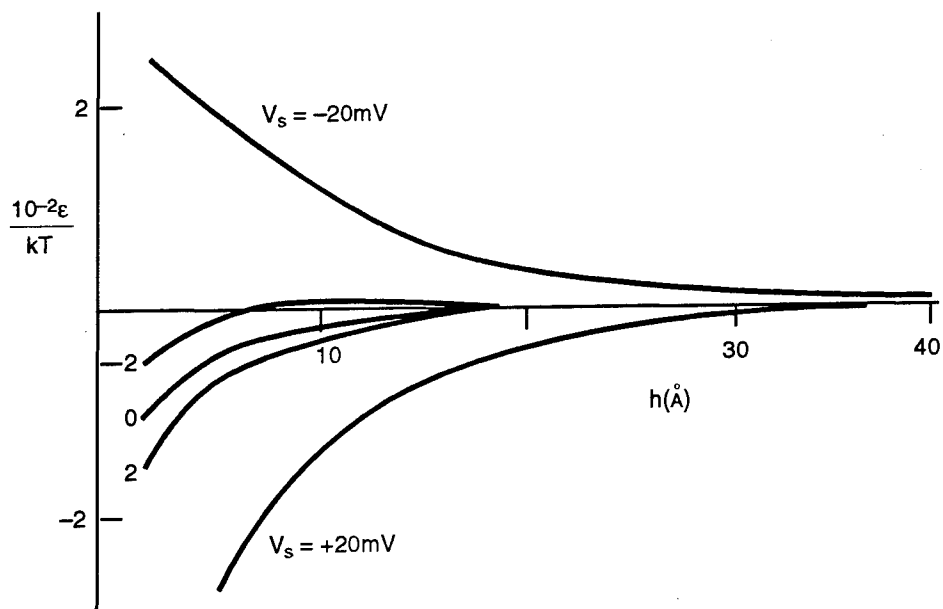

Figure 3-4. Electrostatic interaction energies with constant potentials for different values of V_s and $V_b = -20 \text{ mV}$. $\Lambda = \text{\AA}$.

Therefore, although the short distance wall-bacterium Coulomb interaction is so model dependent that quantitatively reliable estimates of it are questionable, its value at $h > \Lambda$ and certainly for $h \sim h_{\min}$ should be unambiguous.

3.2.2 van der Waals Forces

The van der Waals interaction between a bacterium and a wall can become the dominant contributor to $\epsilon(h)$ at distance $h \gg \Lambda$ where Debye screening strongly suppresses static Coulomb interactions. The zero-point fluctuations responsible for the van der Waals interaction are mainly high-frequency ones ($\sim 10^{15}$ Hz). The zero frequency screening of static electric fields by ion displacement is no longer relevant at these frequencies.

The van der Waals interaction between a pair of otherwise isolated molecules is always attractive. Quite generally the pair interaction energy

$$\epsilon_{ij} = -\frac{C_{ij}}{r_{ij}^6}, \quad C_{ij} > 0, \quad (3-13)$$

as long as the separation between them, V_{ij} , satisfies $r_{ij} \leq c\omega_0^{-1}$. (Otherwise $E_{ij}\alpha - C_{ij}c/r_{ij}^7\omega_0$). Here ω_0 is the minimum energy of the excited states that contribute to the molecular dipolar polarizability. The total van der Waals

is the sum of the attractive contribution from the image force of s -charges with their images in the metallic b -surface and vice-versa. When the surface charges are individually fixed so that dielectric polarization is the only allowed charge movement in the wall and the bacterium

$$E_2 \sim -V_b^2 \left(\frac{\epsilon_w - \epsilon_3}{\epsilon_w + \epsilon_3} \right) e^{-\frac{2h}{\Lambda}} - V_s^2 \left(\frac{\epsilon_b - \epsilon_3}{\epsilon_b + \epsilon_3} \right) e^{-\frac{2h}{\Lambda}}$$

where ϵ_w, ϵ_b , and ϵ_3 are the dielectric constants of the wall material, the bacterium surface material, and the intervening liquid, respectively. We note that the image force sign now depends upon the differences between the relevant dielectric constants and may be repulsive or attractive.

interaction between two condensed matter objects is often computed as the sum over all interacting pairs (often a quite incorrect assumption). Then the van der Waals attraction between two parallel walls separated by a medium with dielectric constant ϵ_3 would be

$$E_v(h) = -\frac{A}{12\pi h^2} \quad (3-14)$$

with

$$A = \pi^2 n_1 n_2 \epsilon_3^{-2} C_{12} \quad (3-15)$$

and with ϵ_3 evaluated at some characteristic frequency $\sim \omega_o$ and $h \gg c\omega_o^{-1}$. The coefficient A is called the "Hamaker constant". However, it is only constant as long as $h \ll c\omega_o^{-1}$. When h exceeds $c\omega_o^{-1}$, A decreases as $(c/h\omega_o)$. For a bacterium, this decrease will begin when h exceeds several $\cdot 10^2 \text{ \AA}$.

Insofar as the sum over pairs is a satisfactory approximation for $E_v(h)$ the van der Waals attraction between a sphere and wall with the geometry shown in Figure 3-1 is

$$E_v(h) = -\frac{AR}{6h} \quad (h \ll c\omega_o^{-1}). \quad (3-16)$$

The Hamaker constant for the attraction between a bacterium in water and a glass wall has been estimated as

$$A \sim 5 \cdot 10^{-14} \text{ ergs.} \quad (3-17)$$

Summing Equation (3-13) over all pairs can be qualitatively misleading. This is apparent, for example, if we apply that procedure to the interaction between bodies containing weakly bound electrons, and especially to electron conductors where $\omega_o \rightarrow 0$. For harmonic oscillators consisting of electrons with mass m and charge e bound with a free oscillation angular frequency ω_o

$$C_{ij} \sim \frac{\hbar e^4}{m\omega_o^3} \quad (3-18)$$

when $r \ll c\omega_0^{-1}$, and

$$C_{ij} \sim \frac{\hbar e^4 c}{m\omega_0^4 r} \quad (3-19)$$

when $r \gg c\omega_0^{-1}$ so that retardation is important. In both regimes, C_{ij} and the pair-sum estimate for A diverge as $\omega_0 \rightarrow 0$. This would suggest an infinitely strong attraction between metallic plates ($\omega_0 = 0$ for free electrons). This incorrect result comes from the additivity assumption. (It is akin to using an Einstein model instead of a Debye one in considering the low-frequency excitations of a crystal.) A correct general way of including all relevant effects has been given by Dzyaloshinskii, Lifshitz, and Pitaevskii (DLP) [8].

There are two families of normal modes for electromagnetic fields in a homogeneous medium with a dielectric constant $\epsilon(\omega)$. One consists of longitudinal modes (e.g., plasma oscillations) at those frequencies $\omega = \omega_l$ at which $\epsilon(\omega_l) = 0$. The other is that of the transverse modes for which $k^2 = \epsilon(\omega)\omega^2 c^{-2}$. For the inhomogeneous geometry of Figure 3-5, the normal mode frequencies depend upon h and the three dielectric constants $\epsilon_1(\omega)$, $\epsilon_2(\omega)$, $\epsilon_3(\omega)$. Each normal mode with frequency $\omega_n(h)$ has a zero-point energy

$$E_n = \frac{\hbar\omega_n(h)}{2}. \quad (3-20)$$

Then the force between the walls 1 and 2 of Figure 3-5 is

$$F = -\frac{d}{dh} \sum_n \frac{\hbar\omega_n(h)}{2} \quad (3-21)$$

and the h -dependent part of the zero-point energy is

$$E_v(h) = \sum \frac{\hbar}{2} [\omega_n(h) - \omega_n(\infty)]. \quad (3-22)$$

DLP find that the longitudinal mode contribution to Equation (3-22) is dominant at sufficiently small h and the Hamaker constant

$$A = \frac{3\hbar\bar{\omega}}{4\pi}, \quad h \ll c/\bar{\omega} \quad (3-23)$$

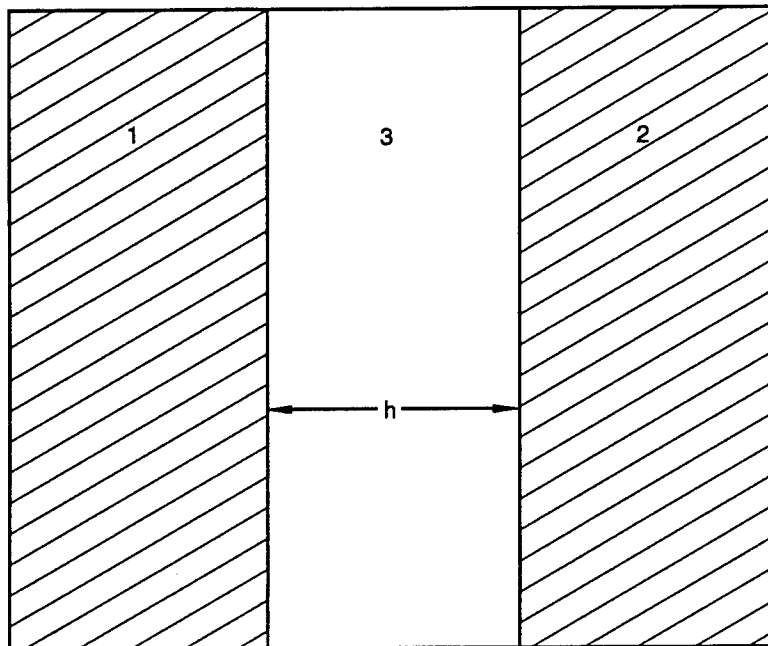

Figure 3-5. Media 1 and 2 separated by a thickness h of medium 3.

with

$$\bar{\omega} = \int_0^\alpha d\alpha \left[\frac{\epsilon_1(i\alpha) - \epsilon_3(i\alpha)}{\epsilon_1(i\alpha) + \epsilon_3(i\alpha)} \right] \left[\frac{\epsilon_2(i\alpha) - \epsilon_3(i\alpha)}{\epsilon_2(i\alpha) - \epsilon_3(i\alpha)} \right]. \quad (3-24)$$

(The ratios in the brackets are just those that enter into the image forces from each surface.) The analytic continuation to imaginary frequency in the $\epsilon(i\alpha)$ of Equation (3-24) is easily accomplished and related to measured $\epsilon(\omega)$ through the Kramers-Kronig relation. This states that any linear causal system (say, of electrons) gives the same response to an electric field as that from a sum of infinitesimally damped harmonic oscillators with various frequencies (ω')

$$\epsilon(\omega) = 1 + \int_0^\infty \frac{\rho(\omega') d\omega'}{(\omega')^2 - \omega^2}. \quad (3-25)$$

The number density of such oscillators with free natural frequencies between ω_1 and $\omega_1 + d\omega_1$, $p(\omega_1) d\omega_1$ satisfies the sum rule

$$\int_0^\infty \rho(\omega') d\omega' = \frac{4\pi n e^2}{m} \equiv \omega_p^2. \quad (3-26)$$

Here n is the spatial number density of electrons. (We assume that virtual electron transitions dominate the van der Waals attraction between bacteria and walls.) From Equation (3-25) with ω approaching the real axis from above

$$\frac{2\omega}{\pi} \text{Im } \epsilon(\omega) \equiv \rho(\omega) \quad (3-27)$$

and

$$\epsilon(i\alpha) = 1 + \frac{2}{\pi} \int_0^\infty \frac{\omega \text{Im } \epsilon(\omega)}{\alpha^2 + \omega^2} d\omega. \quad (3-28)$$

The $\epsilon(i\alpha)$ of Equations (3-28) and (3-24) are positive, monotonically decreasing functions of α that can be quantitatively calculated whenever sufficient measurements of absorptive properties ($\text{Im } \epsilon(\omega)$) of materials 1, 2, and 3 are known. ²

²The needed correction to the $\omega_0 \rightarrow 0$ divergence in A when Equations (3-18) and (3-19) are inserted into Equation (3-15) is now easily seen. Consider materials 1 and 2 to

Several general properties of the Hamaker constant follow from Equations (3-23) and Equation (3-24).

- (a) $A > 0$ (van der Waals force is attractive) if media 1 and 2 have the same dielectric constants.
- (b) $A > 0$ (i.e., a bacterium-wall van der Waals "attraction" becomes a repulsion) if appropriately averaged $\overline{\epsilon(i\omega)}$ satisfy

$$\bar{\epsilon}_1 > \bar{\epsilon}_3 > \bar{\epsilon}_2 \quad \text{a)}$$

or

$$\bar{\epsilon}_1 < \bar{\epsilon}_3 < \bar{\epsilon}_2. \quad \text{b)} \quad (3-29)$$

[This is the case, for example, if 1 is quartz, 2 is decane, and 3 is albumen.]

- (c) When $\epsilon_1 = \epsilon_2$, A is unchanged if medium 3 is interchanged with both medium 1 and medium 2.
- (d) When $(\bar{\epsilon}_{1,2} - 1) > (\bar{\epsilon}_3 - 1)$ the Hamaker A is diminished by the presence of medium 3 relative to its value when $\epsilon_3 = 1$.

A variety of computed values of the Hamaker A (neglecting retardation corrections) based upon measured values of $Im \epsilon(\omega)$ are given in Tables 3.1 and 3.2, together with some A computed with Equation (3-15) [3]. The consist of electron harmonic oscillators with frequency ω_0 so that

$$\epsilon_{1,2} = 1 - \frac{\omega_p^2}{\omega^2 - \omega_0^2}$$

and assume $\epsilon_3 = 1$ (or equivalently, take $\epsilon_{1,2} = 1$ and for ϵ_3 the RHS of $\epsilon_{1,2}$ above). Then from Equations (3-23) and (3-24)

$$A = \frac{3\omega_p \hbar}{64 \left[\left(\frac{\omega_0}{\omega_p} \right)^2 + 1/2 \right]^{3/2}}$$

In the metallic limit, $\omega_0 \rightarrow 0$, and $A \sim 0.13\omega_p$. Quite generally, summing over "isolated" molecular pairs to approximate A is valid only if $\omega_0 \gg \omega_p$.

Table 3.1. Computed values for the Hamaker constant A for identical walls separated by water. Equations (3-23) and (3-24) are used with measured $Im \epsilon(\omega)$ and Equation (3-28) except for values marked * where a version of the summed pair approximation is made [3].

Walls (separated by H ₂ O)	A (10^{-14} ergs)
$\epsilon_{1,2} = 1$	26
decane	3*
benzene	2
bovine albumen	7
dipalmitol	5*
quartz	19*
mica	15*
CS ₂	10

Table 3.2. Same as Table 3.1 except the medium between the walls has $\epsilon_3 = 1$ [3].

Walls (separated by $\epsilon_2 = 1$)	A (10^{-14} ergs)
water	26
CS ₂	82
decane	54*
quartz	100*
mica	15*

Table 3.3. Retardation correction factors for Hamaker A [3].

1 — 3 — 2	β
decane — vacuum — decane	0.3
decane — water — decane	0.2
dipalmitoyl — water — dipalmitoyl	0.3
mica — water — mica	0.2
$(\epsilon_1) = 1$ — water — $(\epsilon_2) = 1$	0.4
borine albumin — water — borine albumin	0.3
quartz — albumin — decane	0.08

intervening medium is water in Table 3.1 and unpolarizable in Table 3.2. Medium 1 is always the same as medium 2.

When all three media are different, the computed A may be qualitatively altered. For example, a quartz and a decane wall separated by albumin give a repulsive $A = -1.3 \cdot 10^{-14}$ ergs.

When $h \geq c\bar{\omega}^{-1}$ retardation effects must be included. These reduce the effective A by a factor of order $c/h\bar{\omega}$. Calculated ratios for $\beta \equiv A(500\text{\AA})/A(10\text{\AA})$ are given for various 1-3-2 wall-liquid-wall combinations in Table 3.3. Because separations of interest are often several 10^2\AA this correction factor is quantitatively important.

Over 2000 calculations have been made [3] for A when walls 1 and 2 are those of a cell and medium 3 is water (Figure 3-6). Calculations were made for various assumed surface coat thicknesses and compositions. All the computed A values (at $h = 50\text{\AA}$) are between $1 \cdot 10^{-14}$ ergs and $4 \cdot 10^{-14}$ ergs, with $A(200\text{\AA})/A(50\text{\AA}) \sim 0.3 - 1.0$. The assumed glass-water-cell Hamaker constant, $A \sim 5 \cdot 10^{-14}$ ergs, near the geometric mean for cell-water-cell and quartz-water-quartz, would seem plausible.

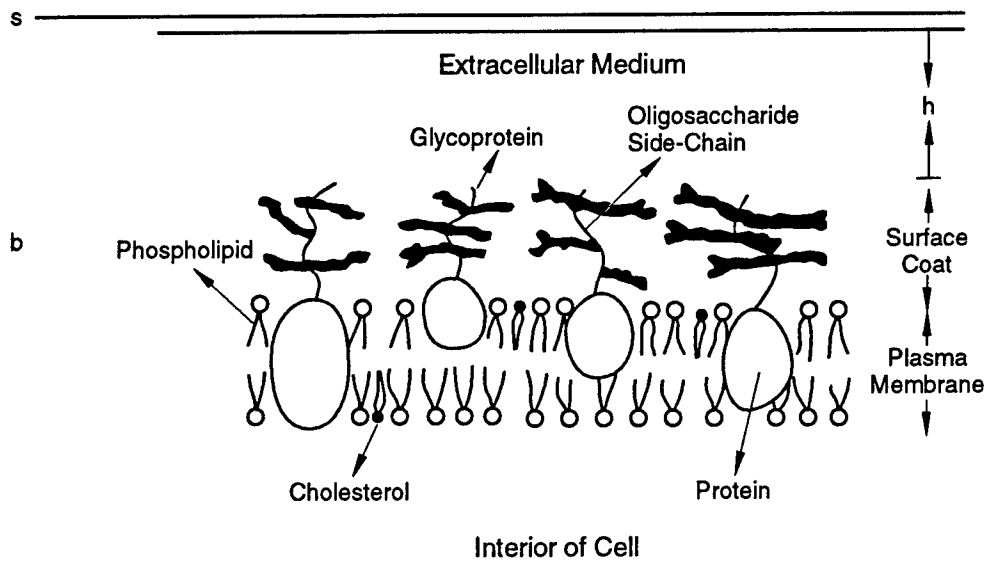

Figure 3-6. Model for a cell surface used in van der Waals force calculations [3].

3.2.3 Wall-Cell Attraction at Large Separations

From Equations (3-15), (3-16), and (3-17)

$$E(h) = E_c(h) + E_v(h) = 3 \cdot 10^{-11} \left(\frac{R}{10^4 \text{ cm}} \right) e^{-h/\Lambda} - 8 \cdot 10^{-15} \left(\frac{R}{h} \right) \text{ ergs} \quad (3-30)$$

for $\Lambda \ll h < c\bar{\omega}^{-1}$. Without the van der Waals attraction, the distance of closest approach of the rigid spherical bacterium and a wall was the $h_{\min} \sim 7\Lambda$ of Equation (3-11) where $E_c(h_{\min}) \sim k_B T$. At that distance, the van der Waals attraction

$$E_v(h_{\min}) \sim 8 \cdot 10^{-15} \frac{R}{7\Lambda} \text{ ergs} \sim 2 \cdot 10^{-2} \left(\frac{R}{\Lambda} \right) k_B T. \quad (3-31)$$

Then $E(h)$ could be attractive *and* exceed $k_B T$ only if

$$\Lambda \leq 2 \cdot 10^{-2} R \sim 2 \cdot 10^2 \text{ \AA}, \quad (3-32)$$

corresponding to an electrolyte concentration in excess of about 10^{-14} moles/litre.

The van der Waals attraction should not be effective in holding the modeled bacterium near a wall unless Λ is very much less than that in Equation (3-32). The minimum time it would take for Brownian motion to remove a reversibly attached bacterium, modeled as described above, from an approach distance to a wall of h_{\min} is

$$\tau \sim \frac{h_{\min}^2}{D} e^{\left[\frac{E(h_{\min})}{k_B T} \right]} \quad (3-33)$$

with the bacterium diffusion constant (momentum \times velocity²/Stokes drag)

$$D \sim 10^{-9} \text{ cm}^2 \text{ s}^{-1}. \quad (3-34)$$

For van der Waals attachment to last for $\tau > 10^3 \text{ s}$, $E(h_{\min}) \geq 10 k_B T$. Therefore, even in the absence of any electrostatic repulsion between the

bacterium and a (silicate) wall, an $A \sim 5 \cdot 10^{-14}$ ergs Hamaker constant would give a significant attachment only if $h \leq 10^2 \text{ \AA}$. When electrostatic repulsion is included, an assumed rigid spherical *Achromobacter* R8 bacterium ($R \sim 0.4 \mu$) could attach with van der Waals forces alone for more than 10^3 s only if $\Lambda < 20 \text{ \AA}$ ($h_{\min} < 80 \text{ \AA}$). However, there is evidence that *Achromobacter* R8 bacteria can accomplish strong attachment even when $\Lambda \gg 20 \text{ \AA}$ [9]. Figure 3-7 shows how the measured attachment after an hour (N_a) varies with Λ [10]. The number of attached bacteria is well represented by

$$\begin{aligned} N_a &= N_0 \ln \frac{\Lambda_0}{\Lambda}, & \Lambda < \Lambda_0 & \quad \text{a)} \\ &= 0, & \Lambda > \Lambda_0 & \quad \text{b)} \end{aligned} \quad (3-35)$$

with $\Lambda_0 \sim 250 \text{ \AA}$. With this Debye length, the van der Waals attraction at the minimum distance of approach is only about $k_B T$, and it is difficult to see how it would play a major role in near-threshold attachment ($\Lambda \sim \Lambda_0$) if the bacterium is adequately described by the model.³

Therefore modelling a bacterium as an inert spherically symmetric charged shell interacting with a similarly charged smooth conducting wall seems much too simple to describe bacterium-wall adhesion or even how the bacterium attaches temporarily (and reversibly) for a time long enough ($\geq 10^2$ s?) for a polymer bridge to grow between the bacterium and the wall.

One obvious oversimplification is the assumption of exact spherical symmetry for the bacterium. In an electrolyte, the electrostatic interaction between a bacterium and a wall falls off so rapidly with separation h in the

³If attachment is accomplished by one or more surface molecules reaching out beyond the nominal spherical surface to attach to the wall, Equation (3-35) would imply that the probability for such an extension to a distance between l and $l + dl$ is $P(l)dl = kdl/l$ if $l < l_0$ and zero if $l > l_0$, with $l_0 \sim 10^3 \text{ \AA}$. This is very different from the

$$\log P(l) \propto - \frac{(l - l_0/2)^2}{l_0 \lambda}$$

l -distribution of a randomly oriented chain of length l_0 and link length λ .

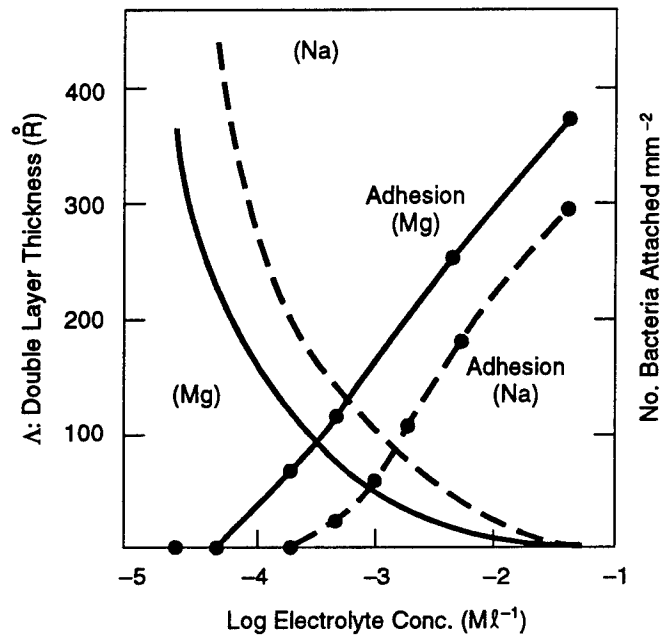

Figure 3-7. Effect of electrolyte concentration on Δ an *Achromobacter* R8 attachment to a wall. The electrolytes are Na^+Cl^- and $\text{Mg}^{++}\text{SO}_4^-$ - (by K. Marshall [10]).

$h \gg \Lambda$ regime that only the parts of a bacterium's surface charge nearest the wall are relevant. Similarly, because of the r^{-6} fall-off in Equation (3-13), only the part of the bacterium surface nearest the wall is relevant in Equation (3-16). Therefore, in Equation (3-30), the radius R in the first term on the RHS is the radius of curvature of the bacterium's surface charge layer and in the second is the radius of curvature of its polarizable surface matter, both to be evaluated at the position on the surface nearest the wall. There seems to be no compelling reason for them to be everywhere equal to an average radius or to each other in a living bacterium. Then, if some areas of the bacterial surface are flatter in their distribution of polarization matter with a local radius of curvature $R_c > R$, the van der Waals attraction would be increased by R_c/R when the bacterium orientation brings that area closest to the wall. A similar increase could come from microscopic wall irregularities as long as those parts of the wall nearest the bacterium do not carry wall surface charge. If $V_{s,b} \sim -20mV$ and $\Lambda \sim 10^2 \text{\AA}$, the average separation between surface charges on both objects

$$a \sim \left(\frac{4\pi e\Lambda}{\epsilon V_{s,b}} \right)^{1/2} \sim 10^2 \text{\AA}. \quad (3-36)$$

Surface irregularities might then bring uncharged parts of the wall much nearer the bacterium, where the combination of increased attractive van der Waals force and an increased attractive image force (cf. second equation in footnote 1) might be enough to allow reversible binding during which a more permanent colloidal bridge could cement cell-wall attachment.

If the general shape of a bacterium departs greatly from a spherical one, the wall-bacterium van der Waals attraction can become much larger. Thus, if the sphere of radius R is replaced by a cylinder of radius R and length L , then $E_v(h)$ depends sensitively upon the orientation of the cylinder. It is, or course, largest when the cylinder axis is in a plane parallel to the wall

surface. In this case, the attractive van der Waals potential of Equation (3-16) is increased by a factor $(L/Rh)^{1/2}$. This could be sufficient to make $E_v(h)$ much more than $k_B T$ even at $h \sim 10^3 \text{ \AA}$. If the bacterium could offer a flat surface to the wall, the increase in $E_v(h)$ would be even greater.

The very complex and dynamic structure of a living cell may allow probes and protuberances almost to touch a wall even when the average distance of closest approach $h_{\min} \sim 7\Lambda \sim 10^3 \text{ \AA}$. If the effective radius of an uncharged "probe" head exceeds 30 times its approach distance, then van der Waals attraction can attach it to a wall with a binding energy $> 10k_B T$. A single chemical bond or ion-image binding could also give a similar attachment energy.

Finally, natural walls are very far from smooth on the sub-micron scale. Their representation as smooth uniform surfaces ignores special properties of very small patches that could increase the strength of attraction to certain cell surface areas as well as pervasive irregularities.

Groundwater slowly moving through rock pores and capillaries would be expected to have a large electrolyte concentration: if very old it may exceed 10^{-2} m which would give $\Lambda < 15 \text{ \AA}$. In such strong electrolytes Equation (3-31) gives $E_v > 14k_B T$ at $h \sim 7\Lambda < 10^2 \text{ \AA}$ so that semi-permanent, but reversible, van der Waals attachment to walls may be expected even without the help of ultimate polymer bridging. In the strong electrolyte regime, it does not appear necessary to understand the complicated active nature of a cell surface to account for expected attachment. However, penetration of a spherically symmetric bacterium actually to touch a smooth uniformly charged wall surface would still require overcoming a barrier of order $10^2 k_B T$.

The attractive force for the van der Waals interaction of a spherical bacterium with a smooth glass wall (F) is about $E(h)/h$:

$$F_v \sim \frac{AR}{6h^2} \sim 10^{-6} \left(\frac{10^2 \text{Å}}{h} \right)^2 \left(\frac{R}{10^4 \text{Å}} \right) \text{ dynes.} \quad (3-37)$$

This force cannot be compared directly to that from possible van der Waals attachment because the detachment left “polymer footprints” on the attaching wall surface: the polymer bridges that formed in attachment and were broken in detachment may have contributed the major attachment force. The force from a single bacterial molecule held to a wall by covalent, ionic, or image force binding would contribute a detachment threshold force

$$F \sim \frac{1eV}{\text{Å}} \sim 2 \cdot 10^{-4} \text{ dynes} \quad (3-38)$$

about equal to the largest measured one [10].

The importance of van der Waals forces in attachment might be explored by experiments in which wall materials are varied. If a wall is made of material that satisfies Equation (3-29), the van der Waals interaction is no longer attractive. [If a glass or quartz wall could be replaced by, say, a copper one with a sufficiently thin ($\ll 10^2 \text{Å}$) glass or quartz surface layer, the van der Waals part of the cell-wall interaction with a water intermediary might be greatly diminished or reversed.]

3.3 Assessment of the Energetics and Kinetics of Adhesion

In the context of bioremediation, the major motivation for developing quantitative measures of bacterial adhesion is to be able to predict rates of

transport in porous media. Unfortunately, as described in the previous Subsection (3.2), the theoretical basis for understanding adhesion of bacteria to walls is limited to the Derjaguin-Landau-Verwey-Overbeek (DLVO) model developed to describe adsorption of colloids. While this model allows us to understand the important physical factors in adhesion qualitatively, it cannot be used for quantitative prediction of the behavior of any real bacterium. Furthermore, with a few exceptions, experimental studies of bacterial adhesion available in the literature provide only qualitative information. There are very few qualitative measurements of energetics or kinetics of adhesion that could be used to evaluate rates of mass transport, even for specific systems. Studies that would allow general quantitative predictions relating adhesion to cell-wall properties are nonexistent. Thus, the analysis we present below is made for a generic case to illustrate the nature of the information needed and the ranges of parameters that are physically reasonable.

The DLVO model of cell-wall adhesion can be used to illustrate the general trends of bacterial adhesion. The interaction strength can be computed as a function of distance between the bacterium and the wall using Equations (3-2), (3-3), and (3-16) with representative values for the effective potentials and the Hamaker constant [3], [11], [12]. The results are shown in Figure 3-8 for a range of solution ionic strengths comparable to sea water (2×10^{-1} M), old groundwater (2×10^{-2} M), and new groundwater ($2 \cdot 10^{-3}$ M). It is immediately apparent that the nature of bacterial adhesion changes qualitatively over the range of ionic strengths relevant to subsurface remediation. At high ionic strengths, the adhesive interaction is strongly attractive, resulting in binding energies much larger than the thermal energy, and thus irreversible adhesion [13] [14]. At low ionic strengths, the repulsive electrostatic interaction is so strong that adhesion is impossible if only the physical (as opposed to

Distance, Å	A_{131} , 10^{-14} erg mica-water-mica (Table 4A, [3])	A_{232} , 10^{-14} erg cell-water-cell (Case 3, Table 6, [3])	A_{132} , 10^{-14} erg mica-water-cell $A_{132} = \sqrt{A_{131} A_{232}}$
10	21		
50	17	5.8	9.9
100	14	4.4	7.8
200	9.6	2.5	4.9
500	6.3		

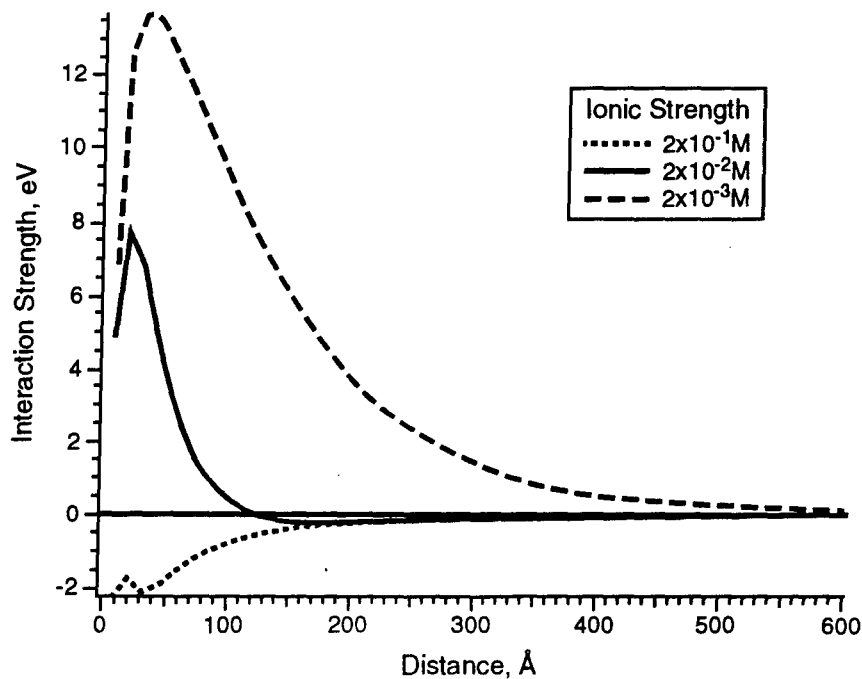

Figure 3-8. Interaction energy as a function of distance from the wall calculated using the DLVO model described in Section 3.2. The curves show the characteristic secondary minimum in potential energy, which is separated by a strong potential energy barrier from the primary minimum (not shown) at less than 10Å from the surface. Parameters used in the calculation were a bacterial radius of 1µm, 30mV and 20mV for the effective potentials on the bacterium and wall respectively. Values of the distance-dependent Hamaker constants, A , used for calculating cell-wall interactions are shown below.

biological chemical) mechanism of adhesion is in effect. The tremendous variability in the strength of interaction with ionic strength has two important consequences. The first is that bacterial adsorption may change dramatically if the environment changes as the bacteria move through the subsurface. The second is that model predictions of the interaction are so sensitive to the parameters chosen that experimental measurements are essential to accurate prediction.

Once the interaction strength is known, then the kinetics of adhesion can be determined using standard approaches. The motion of a bacterium (in the absence of biological motor motion) is described by the Langevin equation [15]

$$m \frac{dv}{dt} = F_{\text{wall}} - 6\pi\eta r_{\text{bac}} v + F(t) \quad (3-39)$$

where F_{wall} is the force due to the interaction with the wall, which is opposed by the viscosity of the water η acting on the motion of the spherical bacterium of radius r_{bac} , and $F(t)$ is the stochastic force on the bacterium due to the random collisions of surrounding water molecules. Far from the wall, the bacterium's motion will be Brownian, with a diffusion coefficient

$$D = \frac{kT}{6\pi\eta r_{\text{bac}}} = 2.2 \times 10^{-9} \text{ cm}^2 \text{ s}^{-1} \quad (3-40)$$

for a radius of $1\mu\text{m}$ and the viscosity of water $\eta = 0.01 \text{ g/cm}^2$. In a region of constant force, the bacterium will be accelerated to a steady state velocity.

$$v = \frac{F}{6\pi\eta r_{\text{bac}}} \quad (3-41)$$

The time constant to reach steady state is $t_{1/2} = 0.1 \text{ ms}$, which allows a random Brownian displacement of approximately 100\AA in the time required to reach $1/2$ of the steady state velocity.

A qualitative analysis of the rates of adsorption based on these concepts is sufficient for the purpose of illustration here. The forces near the wall for the interactions in intermediate ionic strength solution (solid curve in Figure 3-8) are shown in Figure 3-9. The bacterium experiences repulsive forces on the order of 10^{-5} dynes near the wall, as shown in Figure 3-9a. However, during an approach from solution, it first experiences attractive forces pulling it into the secondary minimum of potential energy. These forces are two orders of magnitude smaller than the repulsive forces near the wall, but they are still sufficient to accelerate the bacterium to speeds of $10\mu\text{m/s}$ as it approaches the secondary minimum. A quantitative analysis of the kinetics of approach to the wall using Equation (3-39) will yield a macroscopic rate parameter governing adsorption. This is most typically described as a sticking probability or sticking coefficient, which is just the probability that a particle approaching the walls adsorbs rather than returning to the bulk solution. From the estimates of the speed of approach, it is clear that in the moderate ionic strength solution, the sticking probability will be close to one. However, with decreasing ionic strength, the probability will decrease rapidly, until in the case of low ionic strength, shown by the long-dashed curve of Figure 3-8, it will be essentially zero.

Once a sticking probability is determined, the rate at which bacteria will adhere to walls can be calculated using standard methods of mass transport, without having to incorporate the potential energy near the wall into the

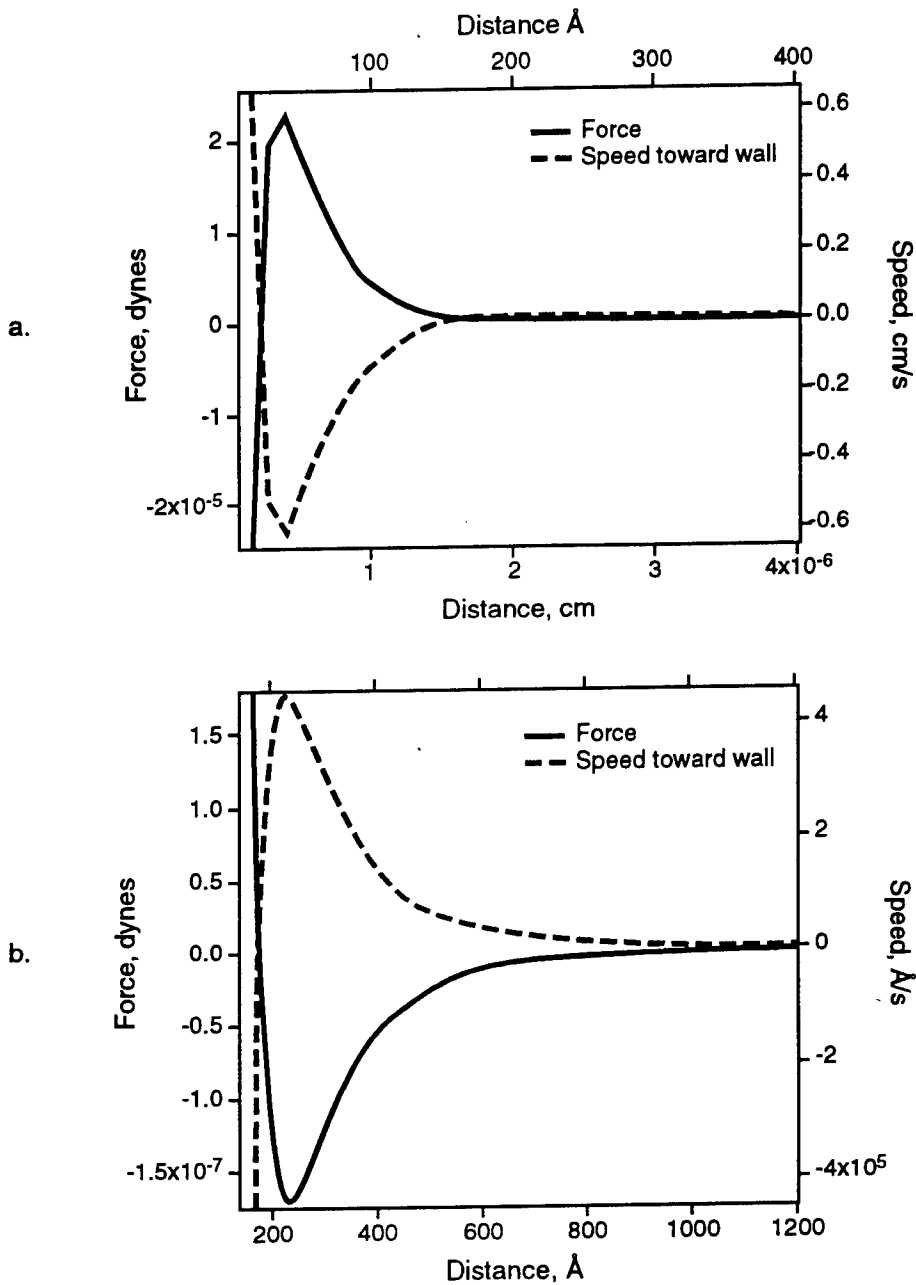

Figure 3-9. Force exerted by the wall on a bacterium as a function of distance from the wall. The values are calculated for the interaction potential of moderate ionic strength (solid curve) of Figure 3-8. The steady state speeds corresponding to the forces were calculated using Equation (3-41 a.). a) Strong repulsive forces near the wall are dominated by the strong maximum in the potential energy at approximately 30 \AA . b) At larger distances weakly attractive forces accelerate approaching bacteria into the secondary minimum of the potential energy curve.

analysis.⁴ The problem of interest is the case where a clean wall is suddenly exposed to a solution of bacteria of concentration c_0 . Mass transport is governed by the equation

$$j(x, t) \approx -D \frac{\partial c(x, t)}{\partial x}, \quad (3-42)$$

where j is the flux to the wall, c is the concentration, and x is the distance from the wall, which must be combined with the requirement of mass conservation,

$$\frac{\partial c(x, t)}{\partial t} = \frac{\partial j(x, t)}{\partial x}. \quad (3-43)$$

The effect of the attractive potential due to the wall is accounted for by the boundary conditions, which are expressed in terms of the sticking probability p , as

$$c(0, t) = (1 - p)c_0, \quad \text{and} \quad c(\infty, t) = c_0. \quad (3-44)$$

This is a standard problem in adsorption, and yields the solution for the flux to the wall [16]:

$$j(0, t) \approx \frac{-Dpc_0}{\sqrt{\pi Dt}}. \quad (3-45)$$

This has the physical meaning of a drop in concentration from the bulk solution value of $c(\infty) = c_0$ to $c = (1 - p)c_0$ over a diffusion layer of thickness

⁴If the potential energy is included explicitly, the one-dimensional flux of bacteria toward the wall must be calculated using the standard expression

$$j = \frac{-Dc}{kT} \frac{\partial \mu}{\partial x},$$

where c is the concentration of bacteria and μ is the chemical potential, which includes a term due to the potential energy $V(x)$ near the wall,

$$\mu \approx kT \ln c + V(x),$$

yielding

$$j \approx -D \frac{\partial c}{\partial x} - \frac{-Dc}{kT} F(x).$$

$\sqrt{\pi Dt}$. Using the value of the diffusion coefficient from above, and a solution concentration of $10^8/\text{cm}^3$, we find the rate of absorption of bacteria onto the wall in any time interval to be approximately

$$\Delta N(t_2 - t_1) = p(5 \times 10^3/\text{s}^{1/2} - \text{cm}^2)(t_2^{1/2} - t_1^{1/2}). \quad (3 - 46)$$

The fraction f of the bacteria lost from solution in a tube of radius r then becomes

$$f = \frac{p}{r}(5 \times 10^{-5} \text{cm}/\text{s}^{1/2})(t_2^{1/2} - t_1^{1/2}). \quad (3 - 47)$$

This rate of loss would continue until the density of adsorbed bacteria became large enough to block adsorption of additional bacteria, and then would fall to match the rate of desorption when the equilibrium surface concentration was reached. The effects of rates of loss of this magnitude on transport through porous media are illustrated in Subsection 3-4 for a case equivalent to a sticking probability of $p = 10^{-4}$.

From the discussion presented above, it should be clear that a realistic assessment of the rate of adsorption of bacteria onto walls (and thus the rate of transport through porous media) cannot be made in the absence of experimental measurements. Somewhat surprisingly, there is very little data available in the literature to provide the needed information. For specific systems, standard batch measurements in which the number of bacteria lost from solution is monitored as a function of time would be useful if carefully designed. However, the results of such measurements are difficult to extrapolate to variable conditions. A better alternative would be to perform experiments that measure the forces of adhesion directly. Such measurements would yield information that can be directly applied to predictions of kinetics and that would allow the nature of the mechanisms to be determined so that extrapolations to different conditions could be made with confidence. A

major question that should be addressed by such studies is under what conditions physical interactions dominate and under what conditions biological interactions dominate.

The application of direct force measurements to the study of adhesion is thoroughly understood [17]. For the study of bacterial adhesion, at least two types of measurement techniques could be applied to quantify the force on the bacterium as a function of distance from the surface. One technique would be to combine the interferometric microscope measurements that are already in use to study bacterial adhesion [18] with laser trapping techniques that are of increasing utility in microbiology [19]. The forces that can be generated on a bacterium with a focused laser beam can be as large as 10^{-6} dyne at powers that do not damage the bacterium [20]. This is sufficient to probe the long-range forces of chemical and physical interaction as illustrated in Figure 3-9. However, it will not allow direct measurement of the short-range forces nor of the forces due to biological adhesion discussed in Subsection 3.2. The laser trap could be used to place a bacterium near the surface, and its motion could be followed dynamically following release to measure rates of adsorption [45]. Alternatively, the trapped bacterium could be moved to different distances from the surface by moving the beam, and the force of interaction determined by varying the laser intensity until the trapping force was insufficient to match the force due to the surface. Finally, the bacterium could be held at a fixed position, and the time constant for biological adhesion to occur and pull the bacterium out of the trap could be determined. This approach has the benefit that it is non-intrusive for the bacterium. It has the limitations of requiring a transparent and smooth substrate (for the interference microscope), so that the role of substrate heterogeneity could not be probed readily.

Another measurement technique that could be used is Atomic Force

Microscopy (AFM) [21] [22]. In this technique, the force between an object and a surface is measured by placing the object on a very soft cantilever beam and measuring the deflection of the cantilever as it is moved relative to the surface. Forces as small as 10^{-7} dynes are readily detected in this way so that short-range physical and biological interactions could be measured directly using AFM. This technique would require devising methods of attaching a bacterium to the cantilever without perturbing its function. Once accomplished, the technique would allow adhesion properties to be measured under any conditions, and in particular, the influence of surface heterogeneity could be probed directly by moving the probe to different locations above a rough surface.

3.4 Flow Induced Force on Wall-Attached Bacteria

In the regime of interest, there is a very slow flow of liquid through very narrow capillaries and cracks to a depth far below the earth surface. This flow is assumed to be driven by the weight of the fluid. The average fluid speed in a capillary with constant radius is

$$\bar{v} = \frac{ga^2d}{8\eta l} \quad (3-48)$$

where $\eta \equiv$ kinematic viscosity of the fluid

$a \equiv$ capillary radius

$d \equiv$ the change in depth from top to bottom of the capillary

$l \equiv$ the total capillary length

$g \equiv$ the acceleration of gravity.

For $a = 10\mu$, $\eta = 5 \cdot 10^{-3}$ (water at 50°), and $d/l = 10^{-1}$, $\bar{v} = 3 \cdot 10^{-3}$ cm s $^{-1}$.

The Reynolds number of the flow

$$\text{Re} = \frac{a\bar{v}}{\eta} \leq 5 \cdot 10^{-3}(a_{-3}^3) \quad (3-49)$$

is far below unity if $a \ll 10^2 \mu$ so that the flow would, in such cases, be expected to be smooth (Pouisselle). At the capillary wall (Figure 3-10) the fluid velocity is zero and its average value near an attached bacterium of radius R is

$$v_b \sim \frac{R}{a} \bar{v} = \frac{gaRd}{8\eta l}. \quad (3-50)$$

The Stokes drag on the bacterium from this flow is, very approximately,

$$F_b \sim 3\pi\rho_l\eta Rv_b \sim \rho_l g \frac{daR^2}{l} \quad (3-51)$$

with ρ_l the liquid density. This (tangential) drag force is independent of η . With

$$\rho_l = \rho(\text{H}_2\text{O}) = 1 \text{ g cm}^{-3} \quad (3-52)$$

the tangential drag is then, roughly,

$$F_b \sim W_b \frac{a}{R} \frac{d}{l}, \quad (3-53)$$

with W_b the weight of the attached bacterium. For $R \sim 1\mu$, $a \sim 10R$, $\rho_l \sim 1 \text{ g cm}^{-3}$, and $l \sim 10d$ Equation (3-51) gives

$$F_b \sim 10^{-9} \text{ dynes.} \quad (3-54)$$

This is a purely tangential drag. A lift-off force enters only when higher orders in v_b are included in calculating the force of the flowing viscous fluid on the bacterium. (If $\text{Re} \gg 1$, with turbulent boundary layers, it is expected to be of order F_d .) For very small Re , as is the case here, any small lift component should not exceed the Oseen correction to the Stokes drag:

$$F_b(\text{lift}) \leq F_b \frac{v_b R}{\eta} \sim \rho_l R^2 v_b^2 \sim 10^{-5} F_b, \quad (3-55)$$

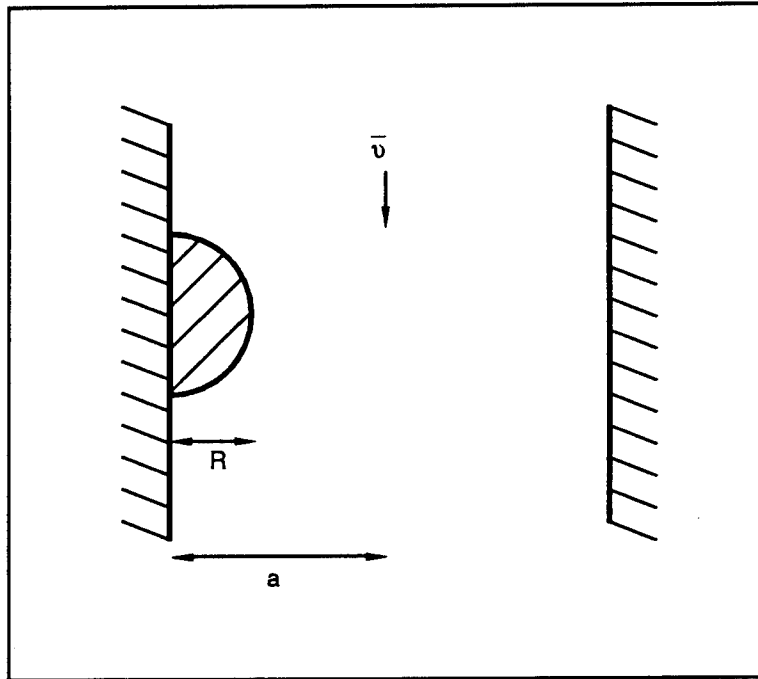

Figure 3-10. Designations for attachment of a hemispherical bacterium to a capillary wall.

a force which is entirely negligible. However, if a bacterium is kept from sliding along a surface in response to the tangential F_b of Equations (3-51) and (3-52) by its interaction with the surface, the flow induced depinning force might approach these values. This can occur in several ways:

- (1) Geometrical path bifurcations. These can stop the bacterium's "glide" in response to \bar{v} at intersection (stagnation) points like those at point A in Figure 3-11. The squeeze on the bacterium from the two-sided flow could give a detachment force

$$F_d \sim \frac{R}{r_c} F_b, \quad (3-56)$$

with r_c the radius of curvature of the attaching surface at the point A .

- (2) Tangential variations in surface properties. The attachment binding energy of a gliding attached bacterium (E_b) can vary with distance (s) along the surface. This will slow the tangential motion of an attached bacterium and cause a detaching torque from the resulting Stokes drag. If $\partial E_b / \partial s$ exceeds that Stokes drag, the bacterium would not move along its attachment surface in response to the flow. The effective detachment force is at most that of Equation (3-55).
- (3) Bacterium attachment to the capillary surface by polymers that anchor to specific sites on the surface. These bridge polymers keep the bacterium from moving in response to the Stokes drag unless that drag exceeds the yield strength of the bridge. However, the calculated attachment forces of Equations (3-37) and (3-38) greatly exceed the maximum flow induced lift.

Geometrical path bifurcations

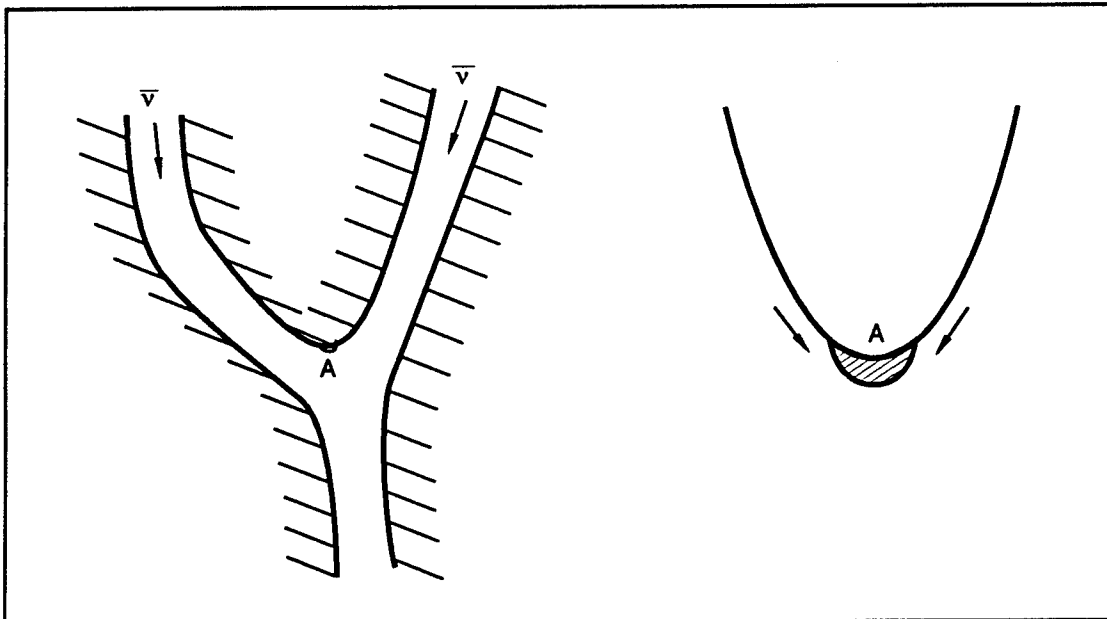

Figure 3-11. Flow induced "glide" of a bacterium to a stagnation point.

3.5 Conclusions and Recommendations

One recommendation stemming from the factors discussed above is that the Subsurface Science Program should more closely coordinate microscopic and macroscopic aspects of research. Specifically, this suggestion is directed at coordination of the characterization of the microscopic properties of cells with characterization of their adhesion, and with studies of mass transport in both laboratory simulation and field studies. Modeling of transport cannot be carried out realistically without adhesion rates of bacteria as an input parameter, and in converse, the significance of changes in cell properties can only be assessed ultimately by seeing their effect on transport. Thus, we recommend strongly that some microbiological expertise be added in the EMSL and that some of the resources of the EMSL be directed toward characterization of cell wall properties and their relationship to adhesion. In Subsection 3.3, some specific types of characterization experiments were suggested that are well within the existing capabilities of EMSL. We do not recommend instituting an open-ended fundamental study of bacterial adhesion within EMSL. Instead, we recommend a strongly focused collaborative effort with other aspects of the subsurface program, in which adhesion measurements are made to correlate directly with the bacteria and conditions to be used in macroscopic transport studies.

4 TRANSPORT OF BACTERIA THROUGH POROUS MEDIA

Many of the proposed applications for bioremediation involve the transport of bacteria through porous rock to contaminated zones underground. Transport through porous media is an area of quite active research (see e.g., [23]) and there are some relatively simple but nonetheless qualitatively useful methods for predicting how material will propagate under the joint action of advection by the flow and diffusion. In this section we will consider a network model of a porous rock formation and modify the usual treatment of dispersion in order to account for bacterial adhesion. The results of this exercise lead to several serious concerns that must be dealt with in any attempt at subsurface bioremediation; these will be detailed at the end of this section.

Part of the difficulty in studying the issue of bacterial transport through porous media is that there is no one typical situation. Instead, each subsurface geology, hydrological setting, bacteria type, etc., leads to a problem with different considerations [24]. The approach taken here is to focus on one possible situation—transport of 1 μm gram negative bacteria through a sandstone formation that is completely water saturated (i.e., below the water table). We will neglect bacterial chemotaxis (until the discussion section at the end) and assume a diffusivity of $2 \times 10^{-9} \text{ cm}^2/\text{sec}$. The flow rate will be taken to be $10^{-5} \text{ cm}/\text{sec} \sim 3 \text{ m}/\text{year}$. If one assumes a typical path length in the porous rock to be one grain size (chosen to be $2 \times 10^{-2} \text{ cm}$), the dimensionless number governing the relative importance of advection vs. diffusion

takes the form

$$Pe = \frac{vl}{D} \sim 100.$$

This means that advection is the major means of transport and dispersion (that is longitudinal spreading of an initial pulse of tracer) is dominated by the diffusive hopping among the various streamlines of the flow-field. Figure 4-1 shows what the concentration field of a tracer looks like in this high Péclet number regime.

To get started towards the porous media calculation, we begin with the simplest problem to consider, a molecular scale tracer in a fluid flowing through a cylindrical tube. The basic equation to be solved is

$$\frac{\partial c}{\partial t} + (\vec{v} \cdot \vec{\nabla})c = D_m \vec{\nabla}^2 c, \quad (4-1)$$

where the velocity is given by the Poiseuille flow field

$$\vec{v} = 2\hat{z}v_m \left(1 - \frac{r^2}{R^2}\right). \quad (4-2)$$

Following Taylor and Aris [25], one can easily determine the effective diffusion constant as follows. Let us write

$$c = \bar{c}(z) + \delta c(r, z). \quad (4-3)$$

We will assume that the variation in z (and t) is sufficiently smooth to allow the transverse profile δc to relax to the solution of a purely radial equation. Specifically, we have upon averaging the basic Equation (4-1) in the r direction

$$\begin{aligned} \langle \rangle \equiv \frac{2}{R^2} \int_0^R r dr \\ \frac{\partial c}{\partial t} + \langle \vec{v} \rangle \cdot \vec{\nabla} \bar{c}(z) + \langle \vec{v} \cdot \vec{\nabla} \delta c(r, t) \rangle = D_m \frac{\partial^2 \bar{c}}{\partial z^2}. \end{aligned} \quad (4-4)$$

To find δc we use the residual equation,

$$(\vec{v} - \langle \vec{v} \rangle) \cdot \vec{\nabla} \bar{c}(z) = D_m \left(\frac{\partial^2 \delta c}{\partial r^2} + \frac{1}{r} \frac{\partial \delta c}{\partial r} \right), \quad (4-5)$$

Scaling Structure of Tracer Dispersion Fronts In...

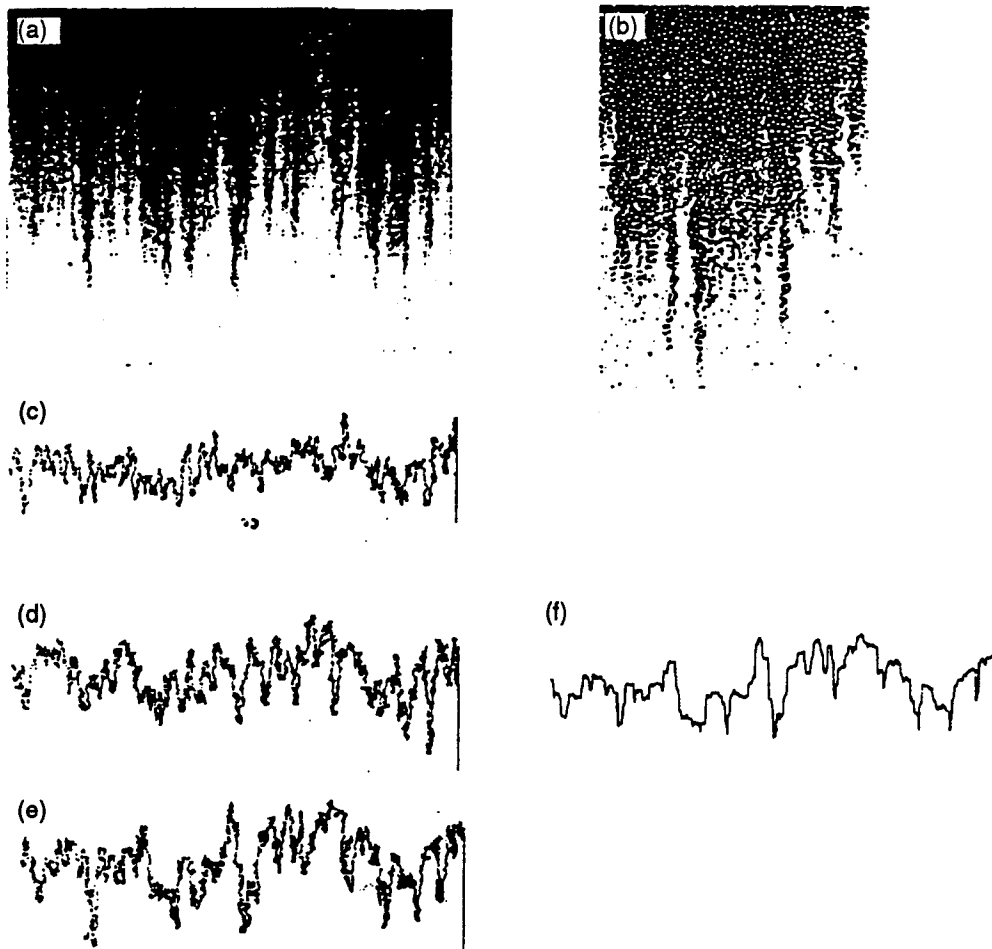

Figure 4-1. (a) Digitized photograph of the dispersion front. The experiment was conducted at Péclet number $Pe \sim 4 \times 10^4$. The size of the image is 1000 x 700 pixels. (b) Close-up photograph of the dispersion front showing concentration variation from the sub pore size scale up to the tens of pore sizes. White dots in the photo are glass beads. (c) - (e) Development of an equiconcentration dispersion front at relative concentration $C/C_0=0.4$. The fronts were taken at times: 135 s (c), 254 s (d), and 400 s (e). The front at time $t=400$ s was reduced to a single value function by replacing parts of the curve within overhangs by straight line segments in x direction (f).

where we have dropped the z and t derivatives of the residual profile in favor of the (larger) radial derivatives. We easily obtain

$$\delta c = \frac{v_m}{D_m} \left(\frac{r^2}{4} - \frac{r^4}{8R^2} - \frac{R^2}{12} \right) \frac{\partial \bar{c}}{\partial z} \quad (4-6)$$

where the last term enforces $\langle \delta c \rangle = 0$. Note that $\frac{\partial \delta c}{\partial r}|_{r=R}$ is automatically zero, i.e., there is no net loss of particles out of the tube. We thus arrive at

$$\langle \vec{v} \cdot \vec{\nabla} \delta c \rangle = \frac{v_m^2}{2D_m} \frac{\partial^2 \bar{c}}{\partial z^2} \left\langle -r^2 \left(r^2 - \frac{r^4}{2R^2} - \frac{R^2}{3} \right) \right\rangle$$

which then implies that Equation(4-4) can be written as

$$\begin{aligned} \frac{\partial c}{\partial t} + \langle \vec{v} \rangle \cdot \vec{\nabla} \bar{c} &= D_{eff} \frac{\partial^2 \bar{c}}{\partial z^2} \\ D_{eff} &= D_m + \frac{v_m^2 R^2}{48D_m}. \end{aligned} \quad (4-7)$$

What changes when we consider transport of a bacterium instead of a molecule? There are several different effects. One is purely due to the size of the bacterium. If we take $1\mu\text{m}$ as a typical size, this is likely to be a fair fraction of a typical narrow passage in a porous rock. This complicates the flow field and at very least prevents the particle from approaching too closely to the wall. If we just exclude this near-wall region for particle occupation, we derive to leading order in $\lambda = a/R$ (a = particle size)

$$\bar{v}_b = \frac{\int_0^{R-a} v(r) r dr}{\int_0^{R-a} r dr} \simeq v_m(1 + 2\lambda).$$

Physically, this increase is due to the lack of bacteria at the slowest moving part of the flow field. On the other hand, the narrowing of the range of streamlines available to the particle will reduce the Taylor-Aris dispersion coefficient. For small λ , the results have been worked out by Brenner [26] with the results

$$\begin{aligned} \bar{v} &= v_m(1 + 2\lambda - 4.92\lambda^2 + \dots) \\ D_{eff} &= D_m + \frac{R^2 v_m^2}{48D_m} (1 - 1.86\lambda + 9.68\lambda^2) \end{aligned} \quad (4-8)$$

There are phenomenological relations that extend these small λ results to $\lambda \sim 1$; these are quoted in Sahimi [27]. At least for the medium we consider, the average passageway will have a radius of 10 μm , large enough so that these corrections are 25% quantitative changes. For the smallest channels, the bacterial transport will be highly altered. However, these channels also do not support much flow (they are like the highest resistances in a random resistor network, and the current avoids them) and the advective dominance of the transport means that nothing gets through these pathways anyway. All told, we will neglect the finite size constraint for the case at hand. This will most certainly not be justified in situations with less permeable rocks and/or much slower flow rates.

The next issue to consider is the existence of nontrivial electrostatic forces associated with (negative) charges on the surface of the cell. These forces are strongly dependent on the ionic strength of the aqueous environment and also the nature of the various surfaces involved; these have been discussed at length in other sections of this report. One way of seeing this effect is to consider the change in average velocity due to finite size effects, but now including a charge density of $\sigma \sim 10^{13}$ charges/cm² [28]. At solutions with less than 10^{-2} M electrolyte concentration, we see in Figure 4-2 the expected behavior of a slight increase in average velocity as the size of the bacterium is increased, due to the aforementioned exclusion from the slowest streamlines. As the molarity is increased to numbers typical of sea water, there is a change to the opposite behavior. This is simply due to the trapping of particles at the secondary Van der Waals minimum.

Typical groundwater has an electrolyte concentration in the range 10^{-3} – 10^{-2} M. We will assume that there is no strong minimum and hence no purely electrostatic (reversible) adsorption. Our reason for this is quite simple—if

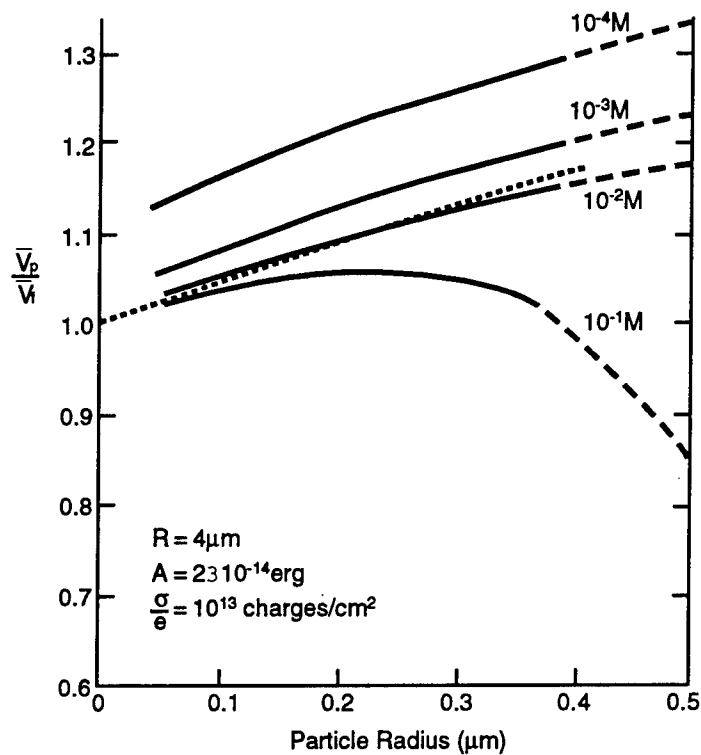

Figure 4-2. Dependence of the velocity ratio on particle radius and the electrolyte concentration of the carrier solution. Ratios less than unity result from nonuniform sampling of radial positions by the Brownian particle in favor of the slow-moving region near the capillary wall. Nonuniform sampling is caused by the lower potential energy of interaction between particle and capillary at separations corresponding to the secondary minimum.

there is such an adsorption, all the bacteria would reach the wall in about the diffusion time for a single pore and everything would stick irreversibly on a time scale very short compared to the needed transit time (hours vs. months). (Indeed this is what is revealed by Table 4.1 which shows the transition from reversible to irreversible adsorption of a *Pseudomonas* strain occurring in about one day.) In other words, the only hope for transport is for adhesion to be a very rare event which is *not* mediated by strong physadsorption. We will therefore proceed with the assumption that we can neglect electrostatic forces.

Another possible complication is that pore walls are quite rough and can create small eddies in the flow as well as snag bacteria on the high points [29]. It is quite difficult to take into account this roughness as part of the hydrodynamic calculation. On the other hand, the actual nature of the surface will automatically be taken care of in the sticking coefficient (see below) if measurements are made with the relevant geological materials.

So, we are left with the one predominant effect that one must consider when trying to estimate the feasibility of bioremediation. As the bacteria transit through the porous media, some of them will irreversibly adhere to the pore walls. This may happen whether or not the bacteria are in a dormant phase—in fact, there are cases when the dormant phase is a better adherent. In regions that lie between the input and the contaminated zone, adsorption represents a net loss of useful biomass. In contaminated regions, adsorption affects the spatial distribution of bacterial deposition and the range over which we can use advection to scatter the bacteria and not rely on the much slower process of contaminant diffusion. Let us assume for simplicity that we are never in the situation of having a large fraction of the possible sticking sites filled with bacteria. Then the local flux through the surface can be

Table 4-1.

Proportions of <i>Pseudomonas</i> Strain EK20 Cells Adhering Reversibly and Irreversibly ^a to a Polystyrene Substratum at Different Time Intervals		
Time (h)	% of total bacteria attached	
	Reversibly	Irreversibly
1	89.5	10.5
2	70.7	29.5
3	44.2	55.8
4	27.3	72.7
5	22.0	78.0
6	24.0	75.6
22	9.4	90.6

^a Determined by using ³H-labeled bacterial suspensions in polystyrene petri dishes. After the supernatant was poured off, the washings were retained as the reversibly adhered fraction while the irreversibly adhered fraction remained attached to the substratum.

taken to be

$$D \frac{\partial c}{\partial r} = \alpha d_0 c,$$

where d_0 is the thickness of the layer over which adhesion could occur (possibly a few tens of nm) and α is a rate constant.

We now redo the above Taylor-Aris calculation. The equation for δc now has the more general solution

$$\delta c(r, t) = \frac{v_m}{2D} \left(\frac{r^2}{2} - \frac{r^4}{4R^2} \right) \frac{\partial \bar{c}}{\partial z} + A + B \ln(r/R). \quad (4-9)$$

Using the above boundary condition yields

$$A + \bar{c} + \frac{v_m R^2}{8D} \frac{\partial \bar{c}}{\partial z} = \frac{D}{\alpha d_0} \left(\frac{B}{R} \right).$$

The other condition that needs to be enforced is

$$\langle \delta c \rangle = 0,$$

which yields

$$A - \frac{B}{2} + \frac{v_m R^2}{12D} \frac{\partial \bar{c}}{\partial z} = 0.$$

Solving, we obtain

$$B = \frac{-2\bar{c} - \frac{1}{12} \frac{v_m R^2}{D} \frac{\partial \bar{c}}{\partial z}}{1 + \frac{2D}{\alpha d_0 R}}$$

$$A = \frac{-\bar{c} - \frac{v_m R^2}{24D} \frac{\partial \bar{c}}{\partial z}}{1 + \frac{2D}{\alpha d_0 R}} \left(3 + \frac{2D}{\alpha d_0 R} \right).$$

The critical parameter which governs this differs from the previous case is $2D/\alpha d_0 R$. If we substitute the typical numbers we have been using, we get that this parameter is numerically equal approximately to α^{-1} (if we measure time in units of seconds). Since α^{-1} is fairly large, we can approximate the part of B that depends on \bar{c} as

$$B \simeq \frac{-\alpha d_0 R}{D}.$$

Now the B term in δc represents a net outflow of material from the mean flow. That is, the average value of $\left(\frac{\partial^2}{\partial r^2} + \frac{1}{r} \frac{\partial}{\partial r}\right) \delta c(r, z)$ is no longer zero because of the δ function arising from the $\ln r$ term in δc . It is easy to see that the net flow equation becomes

$$\frac{\partial \bar{c}}{\partial t} + \tilde{v}_m \frac{\partial \bar{c}}{\partial z} = \frac{\partial^2 \bar{c}}{\partial z^2} - \beta \bar{c},$$

where there is a slight modification to v_m and a net loss term

$$\beta = \frac{8\pi D_m}{R^2} \left(\frac{1}{1 + 2D_m/\alpha d_0 r} \right).$$

Using the same approximations as for B above,

$$\beta \sim \frac{4\pi d_0 \alpha}{R}.$$

Note that the diffusion constant has dropped out, since the loss is reaction-limited. In the limit of large α (for example if there is strong physadsorption due to large electrolyte content in the water), we would have obtained the diffusion-limited result $\beta \sim 8\pi D_m/R^2$. For our case, we are using $d_0 \lesssim 10^{-5}$ cm, $R \sim 10^{-3}$ cm, and $\alpha \sim (10^{-4} - 10^{-3})$, giving β in the range 10^{-5} .

We now put this single-channel result into a network model of a porous medium. We use a specific model due to Koplik et al. [30] where the flow is along bonds on a square (in three dimensions a cubic) lattice. These bonds are “allowed” with probability p and there is a critical value of p (the bond percolation threshold) above which there is a cluster that continuously connects an input node to an output node. The widths of the bonds are chosen from a uniform distribution; we have chosen a mean channel size of $10\mu\text{m}$ with the distribution running to $5\mu\text{m}$ to $15\mu\text{m}$. The calculation proceeds as follows. First, the permeability of each channel is determined from its width and the flow problem is solved via an analogous resistor network (as already

mentioned, pressure drop is like voltage, fluid flux like current). This determines the velocity in each bond as well as the ratio of fluid flux to pressure drop for the entire porous medium model. In physical units, the permeability of the medium equals $\frac{\pi \bar{R}^4}{8d^2} f(p)$ where \bar{R} is the average channel radius ($\bar{R} = 10\mu\text{m}$), d the channel length ($200\mu\text{m}$ here) and $f(p)$ is a dimensionless function calculated by the program. Substituting, we get

$$k = 9.4 \times 10^{-10} \text{ cm}^2 f(p)$$

and $f(p)$ for a 20×20 lattice is shown in Figure 4-3. For comparison, permeability in sandstone ranges from 10^{-8} to 10^{-12} . For definitions, we will use $p \sim .7$ in our simulation.

Given the velocities in each channel, we can now solve the mean concentration transport equation to determine how the bacteria move through the medium. The easiest way to do that is to take the Laplace transform of the concentration equations to reduce everything to a matrix problem which depends on the transform variable s . To see how this works, let us consider a channel that connects nodes i and j . The equation to be solved is

$$s\bar{c} + v \frac{\partial \bar{c}}{\partial z} - D \frac{\partial^2 \bar{c}}{\partial z^2} + \beta \bar{c} = 0.$$

The solution takes the form

$$\begin{aligned} \bar{c}(z; s) &= Ae^{\alpha_+ z} + Be^{\alpha_- z} \\ \alpha_{\pm} &= \frac{v \pm (v^2 + 4D(s + \beta))^{1/2}}{2D}. \end{aligned}$$

The boundary conditions involve fixing the nodal concentration $\bar{c}(0, s) = c_i$; $\bar{c}(l, s) = c_j$. After some algebra, we find that one can express the flux from i to j as

$$J_{ij} \equiv S_{ij} \left(v\bar{c} - D_m \frac{\partial \bar{c}}{\partial z} \right) \equiv G_{ij}^+ c_i - G_{ij}^- c_j$$

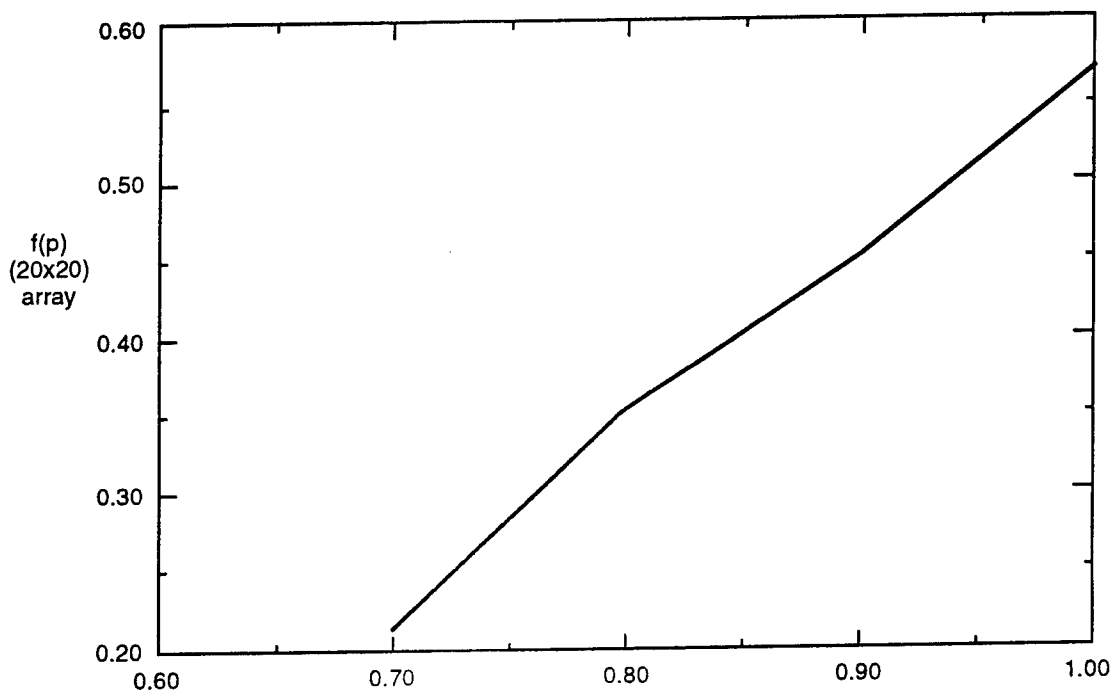

Figure 4-3. Dimensionless permeability from bond percolation network model.

(where S_{ij} is the cross sectional area) and where

$$G_{ij}^+ = \frac{DS_{ij}}{l} (m + m_s \coth m_s)$$

$$G_{ij}^- = \frac{DS_{ij}}{l} (m_s e^{-m} \sinh m_s)$$

with

$$m = vl/2D \text{ (the local Péclet number)}$$

$$m_s = (m^2 + (s + \beta)l^2/D)^{1/2}.$$

Given a source at some overall input node $i = 0$ one can solve the set of network equations

$$\delta_{i0} = \sum_j J_{ij}.$$

The left-hand side is the Laplace transform of a δ function (in time) at the input and all non-input nodes cannot accumulate nor create material. At the output node N , the flux $-\sum J_{Nj}$ represents the first passage time distribution. One can either use an inverse Laplace transform method to recover $P(t)$ or more simply, calculate moments of $P(t)$ via the small s expansion of its Laplace transform. The only change that we had to implement (as compared to the original use of this model for tracer dispersion) was the introduction of non-zero decay rate β . It is easy to show that for $\beta = 0$, $\int P(t)dt = 1$ corresponding to $\tilde{P}(s)|_{s=0} = 1$. Hence, the net loss of material as it passes through the porous medium is precisely $1 - \tilde{P}(s = 0)$. Similarly one can obtain expressions for the mean passage time

$$\langle t \rangle = \int tP(t) / \int P(t)$$

as well as a measure of the longitudinal dispersivity $\langle t^2 \rangle - \langle t \rangle^2$.

For the case we have used as our model calculations, we obtained a throughput of .89 in a 20×20 lattice. Since the bond length is $200\mu\text{m}$,

this corresponds to roughly a 10% loss in 4 m of rock. The average time of passage through the material was 4×10^4 seconds, with a standard deviation due to dispersion of 1×10^4 seconds. These numbers are fairly alarming. If one wants to go through 4 mm of rock, one quickly estimates that only 1 in e^{+100} bacteria survive the journey.

What implications does this have for subsurface remediation? The first point is that estimates based on simple conceptualizations of porous media are probably more useful at this stage than full-blown supercomputer calculations. Models of this sort can be used to study the distribution (and the sticking locations) of bacteria, co-transported nutrients and in fact the original contaminants. For example, the fact that bacteria are transported at large Péclet number but small molecules with diffusivities of 10^{-5} cm²/sec are transported at small Péclet numbers immediately leads to a different distribution inside the rock (the small molecules will explore much more of the “dead-end” parts of the pore space that are not on the main flow path—they will therefore suffer much more dispersion as they move through the porous material).

Specifically we feel that the most glaring uncertainties lie in the sticking coefficient and in fact in the entire realm of how much of the microscopic behavior is determined by relatively unchanging physics and chemistry vs. being determined by microbiology, which can make vast changes in cell physiology, (under the time scales we are considering [31]). Therefore, one should at this stage be using simple porous medium models and estimates (and similarly simple experimental realizations of porous media such as micromodels [32] or bead packs) instead of trying to do large-scale computations and/or experiments in complex geomorphologies, and having the results totally dependent on unknown microbiological issues.

The second point is that we feel the issue of irreversible adhesion is sufficiently serious that it might preclude the use of bioremediation in many cases. One should therefore develop ideas for limiting or at best eliminating this effect [33]. One direct possibility is drilling lots of holes, ensuring direct access (within several meters at worst) to contaminated sites. This is clearly expensive. One could help alleviate loss if one drills several wells and used high pressure to generate much higher than ambient flow velocities that would distribute the bacteria more widely, all else remaining the same. Pumping into rock formations is a standard oil industry technology used during secondary oil recovery. Since the flow rate would only be enhanced to a large degree near the well, many holes would again be needed.

Another possible mitigation approach would be encapsulation of the bacteria in non-sticky containers. In some sense, this is a chemical means of getting a non-adhesive coating on a particular bacterium. One might also imagine doing the same thing by genetically engineering a bacterium and thereby changing its sheath of glycolipids (and other stuff). For the capsule idea, there is a stringent size constraint. We are already pushing the limits of size in getting bacteria through the pore space of sedimentary rock (fractures are probably wider but at least in horizontal transport these are not the pathways that dominate contaminant transport—hence the bacteria go to the wrong spots). Adding a coating (say, placing a bacterium in a 2 μm radius hollow liposome—a self-assembled object made from pure phospholipids) makes matters worse. Using dormant phases of the bacteria would help (these are usually significantly smaller) but then one must ensure that they are “revived” upon reaching the right spot.

The next point is a statement that follows from the dissimilarity in contaminant distribution as compared to any conceivable bacterial distribution

obtained by physical means. Because the contaminants have explored tens of years worth of possible paths in the porous rocks and because they are much smaller than the bacteria (as already mentioned this greatly affects their transport), even under the best of circumstances one will have to wait for contaminants to diffuse out of narrow dead-ends (and possibly to de-adhere) under the action of concentration gradients created by having the bacteria degrade all the contaminant in the bacteria-accessible regions. This means that it takes at least as long to clean up a site as it did to pollute it in the first place. There can be no magic potion based on diffusion of the remediator that undoes years of diffusion of the contaminant without etching the rock to change the pore structure.

The final point is probably the most general. That is, we have in this chapter been treating bacteria as "living colloids" with some fixed set of physical and chemical properties. On a short time scale (say hours) this is quite reasonable. As we start talking about processes that will last years to tens of years, microbiology becomes more relevant than physics. This is both a blessing and a curse. One might be able to rely on colony growth by division, active de-adhesion (if the food supply goes down, bacteria will actively disassociate themselves from walls to try to find more congenial surroundings), chemotaxis, cell adaption to local environments, etc. If the cell "wants" to find the contaminant (i.e., it makes beneficial use of the contaminant in some sort of metabolic process), it may succeed even if the forces of physics and chemistry are somewhat predisposed against it. It is of course a major challenge to figure out how to get bacteria "interested" in a particular undesirable (from the human perspective) material. And this leads directly to the curse part of the dominance of microbiology. On the same timescale, any bioremediant will have to compete in the particular subsurface

ecology with all of the native organisms. Just designing (or finding) the right organism will not do — something which happily digests EDTA but cannot compete with the natives in the particular aquifer which has EDTA-heavy metal contamination is not useful for bioremediation purposes. This is a particularly difficult challenge since our understanding of the microbial ecology of the subsurface is essentially nil. The only logical way to proceed is by working with bacteria already adapted for the particular environment and “breed” into them (either by genetic engineering or by relying on selection in the proper contaminated environment) the ability to degrade the offending “stuff”. One then has to hope that utilizing this stuff gives them enough of a competitive advantage actually to live long, prosper, and thereby clean.

5 METAL BIOPROCESSING

Depending on context, metals are hazardous wastes to be accumulated and disposed of, or economic assets to be recovered from waste or extracted from ores. Microorganisms have a role to play in both of these tasks and have attracted considerable attention in this connection over the recent decades. Metal bioprocessing has been applied to the remediation of contaminated surface and ground waters, to the treatment of industrial waste streams, and in the extractive and waste treatment operations of the mining industry [34].

For bioremediation of waters containing solubilized heavy metals, the various processes of interest in some cases involve metabolically active microbes, in other cases non-living (i.e., non-metabolic) organisms. In *precipitation* processes, soluble metals interact with substances secreted by living microbes to produce insoluble metal compounds. Sulfate-reducing bacteria such as *Desulfovibrio* and *Desulfotomaculum* are a prominent example. In anoxic environments with an abundance of sulfate and degradable organic matter, they induce the production of H₂S and bicarbonate:



The sulfide interacts with soluble divalent metal ions (M) to produce insoluble metal sulfides:

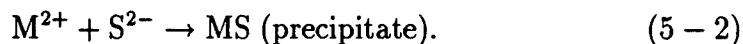

These processes are relevant to the treatment of metal-contaminated waste waters with high concentrations of sulfate and organic matter, and in some places occur naturally. In many applications, e.g., to the acidic drainages

from mining operations, it may be necessary to add the necessary organic compost deliberately or in other ways induce the growth of organic matter.

Intracellular accumulation refers to processes in which soluble metals first attach to the cellular surface of the microorganism and are then transported across the cell membrane to the interior, where they may precipitate or bind to cellular components. Transport across the cell membrane in most cases is thought to involve energy-dependent processes in living organisms. These processes are not yet well understood. It may be that the heavy metals are able to confuse the cell by using the same mechanisms that transport metabolically essential ions such as potassium. The uptake of heavy metals by this process is sensitive to a number of environmental factors in the wastewater, e.g., pH, the presence of molecules that complex the metals, etc. Substantial intracellular accumulations have been observed. For example, with a mixed culture consisting of *Pseudomonas maltophilia*, *Staphylococcus aureus* and a cornyeform organism, accumulation of Ag^+ to a level of 30% of biomass dry weight has been observed.

Metal immobilization through *oxidation and reduction* reactions can be illustrated by the example of oxidation of manganese at chemically reactive sites on the cell walls of *Bacillus* spores:

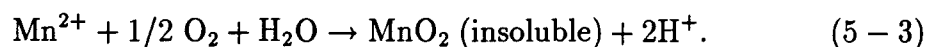

Exemplifying a reduction process, the reduction of gold from Au^{3+} to Au^0 has been detected on the cell walls of *Bacilli subtilis*. *Extracellular complexation* of metals is another mechanism by which bacteria immobilize soluble metals. This arises where the organisms excrete appropriate chelating agents, for example the siderophores that can be isolated from *Pseudomonas*, *Arthrobacter* and other bacterial species. In some cases, there is the prospect

that the complexing agents can be recovered and reused repeatedly for metal accumulation.

The attachment of soluble metals to microbial cells or to the substances excreted by cells is typically quite sensitive to the composition and chemical state of the wastewater that is being treated. Organic and inorganic contaminants can affect the chemistry and availability of the metals for binding to the bioabsorbents. The latter may be subject to attack by chemical substances in the solution, etc. This implies that the appropriate technology for bioremediation of metals may have to be finely tailored to the particulars of the varying applications.

A number of bioremediation processes have been developed and introduced for commercial applications. One of these is the BIOCLAIM process. This is based on microorganisms, principally *Bacillus*, whose cells are deliberately ruptured in a strong caustic solution to expose functional groups with good metal binding capacities. The cell fragments are immobilized on extruded polyethyleneimine beads. Other processes, similarly involving non-living mixtures of biomass that are immobilized on beads that can be used in fixed-bed, fluidized-bed or dispersed-bed reactors, go under the names AlgaSORB and BIO-FIX. At the present time, most of the systems that are in commercial use or that are approaching commercialization are based on non-living bacteria. Living systems have the advantage that they are a renewable resource and that, moreover, they exploit metabolic processes (e.g., the reduction of sulfate to sulfide) not mediated by non-living systems. The difficulty is that waste streams are often toxic to living systems and devoid of nutrients.

Biotechnology is likely to have an increasingly important role in mining,

an industry in the U.S. that is in the course of long-needed modernization. Exploitation of increasingly lower-grade and refractory ores is one of the big challenges to the industry. The refractory ore problem is well exemplified by the case of gold mining. Oxide gold ores, which have been the backbone of the industry, respond well to the standard cyanide method of extraction. Here the gold component in crushed ores complexes with cyanide and the complex is removed by absorption on activated carbon. But reserves of oxide ores are being depleted worldwide and are being replaced by ores that consist of sub-micron particles of elementary gold embedded in a sulfide mineral matrix, e.g., pyrite (FeS_2). The cyanide does not penetrate well here and extractive yields are small, often less than 20% of the available gold. Alternative, non-biological, technologies exist, but they are costly. A biological alternative—bioleaching—involves the use of aerobic, acidophilic bacteria, e.g., *Thiobacillus*, which oxidize sulfur compounds, degrading the sulfide matrix and exposing the elemental gold. Bioleaching of refractory gold concentrates is being pursued commercially in South Africa, Australia, and South America. At the present time, the largest application of biotechnology in mining is to the bioleaching of low-grade sulfidic copper ores. This is now practiced widely throughout the western United States and especially in Chile, chiefly for ores containing chalcocite (Cu_2S) and/or covellite (CuS).

Tightened restrictions on sulfur dioxide emissions from coal-fired power plants have increased attention to pre-combustion desulfurization technology. There would appear to be a vast market for coal biodesulfurization if competitive, cost-effective techniques could be developed. Research with the thermophilic, acidophilic bacterium *Sulfolobus acidocaldarius* for extraction of sulfide and organically bound sulfur has been performed. At the present time, however, commercially promising findings have not emerged.

6 IN SITU RECOMBINANT DNA

In order to accomplish in situ bioremediation one often is faced with the need specifically to “engineer” an organism that will have the desired metabolic behavior for the contaminants at hand. Normally, this engineering is imagined to occur in the laboratory, creating an organism that is both adapted to living in the specific in situ environment (in terms of temperature, pressure, chemical composition, etc.) and able to accomplish the desired degradation. In this section, we explore a speculative but somewhat novel concept—that of using the resident microorganisms and transmitting only the new genetic instructions from the surface.

The first question to be addressed concerns the possible benefits such a scheme might have over more traditional concepts. Essentially, it may be quite difficult to transport desired microorganisms from the laboratory to a specific subsurface environment. This issue is discussed earlier in this report in more quantitative detail, but the qualitative concerns that enter are: (a) will the microorganism be able to survive transit through unfavorable regions to reach contaminated zones; (b) will the microorganism adhere to the surface of the porous media to such an extent as to make long distance transport unattainable; (c) will heterogeneity of a contaminated zone on the scale of meters make predictions of organism viability, made via tests on core samples, rather unreliable; and finally (d) will hard-to-reach spots in the porous medium remain locations of long-term contamination simply because microorganisms can no longer fit through the small throats of diagenetically altered aquifers.

The first two points of this list might be addressed by encapsulating the bacteria for the journey to the relevant location. This idea, coupled with the concept that one will quite often drill wells directly through the rock formation and pump the relevant bioremedial "stuff" directly into the correct stratum, should certainly work in some cases. The basic problem, though, is that even a fairly tightly fitting capsule of, say, 5 μm diameter will have trouble negotiating through the pore space of a typical aquifer. So, though one might diminish wall adhesion by proper capsule choice, one might just get stuck.

On the other hand, sending encapsulated genetic information solves problems (a) and (b) without imposing this severe size constraint. The genetic information would be contained inside a vector, either a virus known to infect some specific microorganism or a plasmid; these could easily fit inside capsules of size .1 μm . The best choice for capsules would be self-assembled liposomes, which could be induced to form spontaneously in a "soup" of genetic material that would be straightforwardly incorporated into the lipid vesicle. These can easily be made in this size scale.

Finally, use of already existent microorganisms will help alleviate (c) (since one could use the locally adapted colonies) and possibly even (d) if the colonies predate the diagenetic activity that led to the "dead ends" of the pore space. Of course, solving all the problems of using laboratory generated organisms by shifting to "reprogramming" in situ colonies merely transfers the difficulty to getting the right instructions to the right place.

Let us assume that we will be using "naked" DNA in the form of a plasmid to do the requisite genetic engineering. We need to find a plasmid that is likely to be able to function in the variety of related species to be found

in situ. These do exist—for example, the famous *R* plasmid, which confers antibiotic resistance, will function in a wide variety of gram-negative bacteria. Next, we must ensure that cells that incorporate the new genetic information are “selected” for by the environment in such a way as to compensate for the disadvantage of carrying extra DNA. The obvious holy grail is that the plasmid will allow the modified bacteria to grow more rapidly by specifically allowing them to metabolize the contaminant that one wants to degrade. If this could be accomplished, one would modify the ambient ecology only in the contaminated zones, and then the modification itself would be selected against as the environment becomes decontaminated.

What are the hard parts? Beside finding the relevant gene insert and vector (these would have to be done in any genetic engineering solution), the actual incorporation might be tricky. It is known how to do this under controlled laboratory conditions, and, in fact, the incorporation of DNA into bacteria was the original experimental finding of Avery that identified DNA as the carrier of genetic information. Whether this could be done with large enough yield in an uncontrolled setting is probably unknown. One could co-transport any specifically needed chemicals to make the bacteria receptive to naked DNA, but one would have to make the right mix in a unpredictable chemical bath. There is certainly no difficulty in testing this experimentally using known host-vector systems. One would also have to design the encapsulated soup to allow for long-term (weeks to months) survival of the plasmid during the transit phase of the remediation effort.

The difficulties in getting this idea to work are non-negligible. One should keep in mind, though, that natural genetic engineering does occur, and cells are quite happy to pick up bits of useful information if it helps them to cope better with their environment. What this probably means is

that even though indigenous microorganisms could eventually figure out on their own how to “eat” a particular contaminant, usefully speeding up this process by directly providing the relevant information should be attainable if the actual competitive advantage to the organism is large enough so that a very small yield will nonetheless lead eventually to a large number of modified bacteria.

7 THE STATISTICS OF CENSUS TAKING

How is one to estimate the subsurface population of the earth?

Well, how does the Census Bureau conduct a census—(poorly)—but apart from that how do they go about it? They go to homes, and count residents. (Thus they miss the homeless, which is hard on New York State when it comes to political desserts.) Even so, they miss some residents because no one was at home when they called—they miss others because some people do not want to be counted or identified in any way.

The problem of taking a microbial subsurface census faces many of the same difficulties, but we may start by finding the homes. To do this we need a reasonably accurate description of the subsurface environment worldwide, and to a fairly great depth (kilometers). This description must include availability of water, porosity, availability of assorted minerals, etc.

Once this daunting task is completed (it includes the tundra, too, of course, as well as the subsoil under the Antarctic ice sheets), we can roughly estimate the microbial population on the basis of two considerations:

1. In an environment which is roughly comparable to one we have seen before and for which we know microbial density, the new environment will have microbial residency much like the old.
2. In any environment where there is a possibility of migration due to porosity or flow, and in which there is available chemical energy in the

mineral landscape, one will find substantial density of microbial life exploiting the available energy.

Occasional sampling of the subsurface, of necessity a very thin sampling, will serve to reinforce or deny one's estimates based on principle #2. Sampling itself will never, we should think, give enough data to estimate reliably the population statistics, in the absence of a very strong initial hypothesis.

8 NUCLEAR WASTE DISPOSAL—BOROSILICATE GLASS

8.1 Introduction

U.S. nuclear waste currently in temporary repositories will be incorporated into borosilicate glass (BSG) for ultimate storage in a geologic repository. BSG was chosen for solidification of high-level radioactive waste at the Savannah River Plant (SRP) over a number of alternative glass (e.g., phosphate glass), glass ceramic, ceramic (e.g., synrock, other ceramics tailored specifically for the waste stream), and mixed materials developed in the 1970s and 1980s [35]. The Australian waste form "synrock" was selected as the first alternative.

BSG has been adopted as the waste form to be used at the Hanford site [36] [37]. This decision was based largely on the analysis in the 1982 report, which in turn heavily relied on the recommendations of a peer review panel (non-DOE research scientists) chaired by L.L. Hench and a report by Schultz (1980). It is not certain that the Hench panel (or an equivalent panel assembled in the late 1980s) would have selected BSG for the Hanford site waste (R. Ewing, member of the Hench Panel, personal communication, 1994), given that commercial scale production of synrock containing non-radioactive waste simulants now has been demonstrated [38]. An excellent review of the alternative waste forms at the time when the Hanford decision was made is [39].

The acceptance of BSG as the sole waste immobilization route was justified based on three main assumptions:

- (1) glasses accommodate variations in waste composition
- (2) glasses are reasonably easy to process and vitrification technology is reasonably well developed
- (3) glasses are reasonably durable.

The general validity of each of the three assumptions noted above is discussed briefly below. The BSG decisions may reflect in part the fact that the NRC/EPA regulations do not require primary reliance for waste containment to be placed on the waste form. However, the long-term hydrology and stability of a geologic repository are difficult to predict, so minimization of reliance on repository design would be preferable. The need for a scientifically based, coordinated program of research to develop a selection of second generation alternative waste forms with enhanced durability, minimized waste volume, lower exposure of humans to radiation during processing, and lower processing costs will be advocated.

8.2 The Problem

At the Hanford site alone there are approximately 180 tanks of waste material awaiting solidification and storage. Large volumes of material are also stored at the SRP (51 tanks comprising 34 million gallons [40]) and West Valley. Materials in these tanks have low to high levels of radioactivity and extremely complex and diverse chemistries. The chemical speciation,

oxidation states of the elements, and the structures of the phases are virtually unknown. In addition, 100+ metric tons of weapons grade Pu (~ 50 tons U.S. waste, 50 tons from the former USSR) await immobilization.

8.3 Borosilicate Glass Waste Loading

The amount of waste that can be accommodated in a glass without phase separation depends on the nature of the waste constituents and the glass composition and structure. While glasses are "flexible" networks (point (1) above) they have quite limited abilities to accommodate important substitutions. For example, the likely solubility of P, a common constituent of waste streams, in BSG may be less than 1%. The Hanford waste contains sufficient phosphorus that it will have to be removed chemically. Otherwise, instead of the 8,000 logs, the tank waste will have to be processed into ~ 200,000 logs (each 25 cubic feet) at the cost of \$1,000,000 per log (unofficial estimate, PNL). Strategies to reduce BSG volumes involve separation from the sludge of constituents that degrade glass stability (e.g., Cs and Sr chlorides and fluorides by ion exchange: PNL is conducting a small amount of research in this area). However, the method of immobilization of separated Cs- and Sr-rich materials is not clear if BSG remains the only available waste form. Unless effective separation strategies are developed, the cost and attendant storage requirements will be of great concern.

The current strategy for waste disposal is designed around manipulation of the waste stream to suit the nature of the BSG product. An alternative approach would be to develop a selection of waste forms suited to variations in the waste stream. For example, alternative glass compositions (e.g.,

Fe-phosphate glasses, more aluminum-rich glasses) might accommodate unmodified or less modified wastes, reducing costs and human exposure during processing.

The above discussion highlights two points: (1) the waste streams must be carefully characterized so that strategies can be designed to separate elements that have low BSG solubilities or undesirable consequences for the glass structure, and (2) alternative waste forms are needed to allow efficient disposal of the full range of waste materials. These research areas are clearly important, and should receive high priority.

8.4 Processability

While under ideal conditions it is likely that BSG could act as a relatively effective barrier to radionuclide release, the complexity of the waste to be stored and processing variables (e.g., BSG performance is greatly affected by flow rate [39]) make this outcome improbable. In part, the initial selection of BSG reflected the perception that it was a “proven” technology (point (2)). Processability was taken into consideration by the Hench panel (1981; Ewing, written communication, 1994) and is discussed extensively in the DOE white paper [37]. At the time of selection there was no operating BSG plant in the U.S. The successful French vitrification operation at La Hague was used to support the choice of BSG. However, it should be noted that the two operating lines at La Hague are dealing with less complex commercial reactor fuel under conditions where the waste stream can be readily manipulated. Thus, the choice to use BSG for SRP and Hanford waste immobilization was not based on experience with U.S. wastes. Partly

for technical reasons associated with the characteristics of the waste stream, the SRP vitrification plant is now billions of dollars over budget and 5 years behind schedule [40]. As of this date, the SRP vitrification facility has not produced any BSG product. Given the details noted in the GAO report, concern over the likely outcome of the Hanford BSG operation is warranted.

As experience with storage of real high-level waste accumulates, the effectiveness of BSG immobilization must be reexamined. This process of reevaluation appears to be occurring elsewhere. For example, the French, Chinese, Japanese, and Russians have all expressed interest in synrock and intend to use it for wastes not suited to BSG (K. Smith, ANSTO Australia, written communication, 1994). It is of great concern that the United States does not have a viable research and development program for second generation nuclear waste forms, since a broader set of options for waste forms (including BSG) might well reduce costs and improve performance in the immobilization of nuclear wastes.

8.5 Durability

While durability is a vital requirement for a nuclear waste form (point (3)), long-term projections are difficult. Based on relatively short-term experiments, numerous studies have argued that several modern ceramic waste forms have much enhanced resistance to corrosion compared to BSG. This should not be surprising as glasses are, by their very nature, metastable compounds. Both comparative experimental studies and examination of naturally and experimentally reacted natural analogs verify that glasses may be easily altered at low temperatures over short times. It should be noted that

natural glasses do not have boron-rich compositions and that their persistence in the near-surface environment reflects their limited exposure to water and not their inherent stability. It is widely known that glass solubility and stability can be degraded by various chemical substitutions. Among the more serious possible consequences of devitrification and phase separation is enhanced solubility of waste constituents in solutions should groundwater come in contact with the stored material. Reimus et al. [41] report 40% increases in leach rates due to devitrification of FY 1987 BSG. Physical degradation through cracking may also accompany crystallization.

BSG disposal strategies have been designed around the inherent instability of BSG at high temperatures [42] [43] [44]. Over relatively short times (geologically speaking), nuclides such as ^{90}Sr and ^{137}Cs (half lives of 28.1 and 30.2 years respectively) generate heat within glasses. Waste loadings of glasses are severely limited by thermal instabilities of BSG. This necessitates a two-stage storage process, places constraints on acceptable repository conditions, and, inevitably, contributes to higher costs due to greater volumes of material to be processed and stored.

8.6 Alternatives and Future Developments

Based on the work conducted up until the time funding for research on alternative waste forms was discontinued and BSG adopted, it is clear that more corrosion-resistant, lower-volume, cost-effective alternatives to BSG can be developed [39]. Although long-term nuclear waste isolation strategies would benefit from the availability of a selection of waste forms, it seems likely that BSG will remain the waste disposal method of choice unless sufficient

research is done to prove that alternative technologies can be developed.

For the future, an active research effort to design a selection of additional waste forms based on a thorough understanding of the nature of the problem (composition, crystal structure of constituent phases, particle size (including colloidal constituents), fluid speciation, system phase relations, etc.) seems essential. The first indication that alternative waste forms are being considered seriously comes from the very recent initiation of a ceramics feasibility program at Lawrence Livermore Laboratories (start date June 1, 1994). However, given the magnitude of the effort required and the extraordinarily large projected costs involved in immobilization of existing wastes, a concerted effort from a team of scientists and engineers analogous to that assembled for the Manhattan Project may be warranted. It is perhaps valid to wonder why the new Environmental Molecular Sciences Laboratory at the Hanford site has not been directed to concentrate significant effort in this area.

9 ENVIRONMENTAL AND MOLECULAR SCIENCES LABORATORY (EMSL)

The EMSL is currently under construction. When completed, it will provide Pacific Northwest Laboratories (PNL) and the Department of Energy (DOE) with a magnificently equipped laboratory. The stated mission of the laboratory is "to advance molecular science and support the long-term missions of the U.S. Department of Energy." As originally conceived, the work in molecular science was to be "far-reaching, *not directly linked to environmental restoration or waste management.*"

The decision to build EMSL was made at a time, the mid-1980s, when an expansive philosophy motivated DOE managers. The Superconducting Supercollider (SSC) was proposed at this time, as well as major new facilities at each of the DOE laboratories. EMSL was to be PNL's prize.

As federal funding for research becomes increasingly tighter, it is imperative to optimize every possible facet of financial and human resources to meet national needs. The restoration of waste sites is a major national priority whose costs are unknown, but could be measured in trillions of dollars for all waste sites. The waste on DOE lands constitutes a significant fraction of the national problem. In 1989, the estimated cost of cleaning up one DOE site, Hanford, was \$40 billion. Just three years later, the estimate doubled to \$80 billion, with more than 30 years required to achieve the cleanup.

The presentations with respect to EMSL reveal clearly the tensions between the view that molecular science should be pursued for its own sake, and the view that the work of the laboratory should concentrate on the science

of cleanup. The magnitude of the cleanup problem was emphasized, along with the irrationality of some of the regulations. But clearly, the science problems associated with molecular dynamics, radiation chemistry, surface science, etc., are the primary interest of the laboratory.

A laboratory with an uncertain mission is bound to fail. Attempting to do basic science as well as cleanup science will inevitably lead to a situation in which the strong members of the laboratory are working at the frontiers of molecular science, while the lesser scientists are given the various applied chores of looking at such issues as tank safety and subsurface transport of contaminants.

We are also concerned about the balance of disciplines within EMSL. To the outsider, the laboratory appears to have been captured by the physical chemists. Physical chemistry is an important subject in its own right, and has much to contribute to the science of cleanup. But the biological sciences appear to have been neglected. Yet many of the most challenging problems of both molecular science and cleanup involve modern biology.

In these times of budget stringency, DOE cannot afford to support a laboratory whose primary mission is to further molecular science while secondarily working on cleanup. The mission of EMSL should be clearly stated: that of developing the science and technology of cleanup. The laboratory's performance and future funding should be determined by the progress the laboratory has made toward developing workable technologies for cleanup. As indicated in our overview of the Subsurface Science Program, the scientific problems associated with cleanup are challenging. They involve surface science in complex media, problems of genetically engineering bacteria, and issues of interaction of fluids with the subsurface. These challenges should

provide a situation in which first-class scientists work in an atmosphere with good morale and high scientific motivation.

9.1 Recommendations for EMSL

As described above, the EMSL is in a difficult process of making a transition from non-focused, open-ended research to mission-oriented research. It is clear that if the transition is successful, the EMSL could make substantial contributions to the remediation efforts being sponsored by DOE. This is because the problems being encountered in the toxic waste cleanup are far beyond the scope of solutions available from the normal problems of industrial chemical processing. If the cleanup is to be successful at a cost that does not bankrupt the nation, innovative solutions must be developed. The role of basic research in the process should be to consider a broad range of novel possible processes relevant to cleanup. For this process to be useful, the ideas developed in basic research must be transferred to a practical testing stage and evaluated for real utility. If truly novel and innovative ideas are pursued, it is clear that only a small fraction of the ideas will be practical, and evaluation of the success of the basic research effort must take this into account. However, it is also clear that successful application of the ideas developed in basic research can only occur if the basic research scientists are responsible for communicating their ideas to those involved in evaluation, and seeing the ideas through the evaluation process.

The organizational charts for the EMSL and its function within PNL are shown in Figures 8-1 and 8-2. The activities of EMSL are organized as four fundamental research sub-groups, Theory Modeling and Simulation, Chemi-

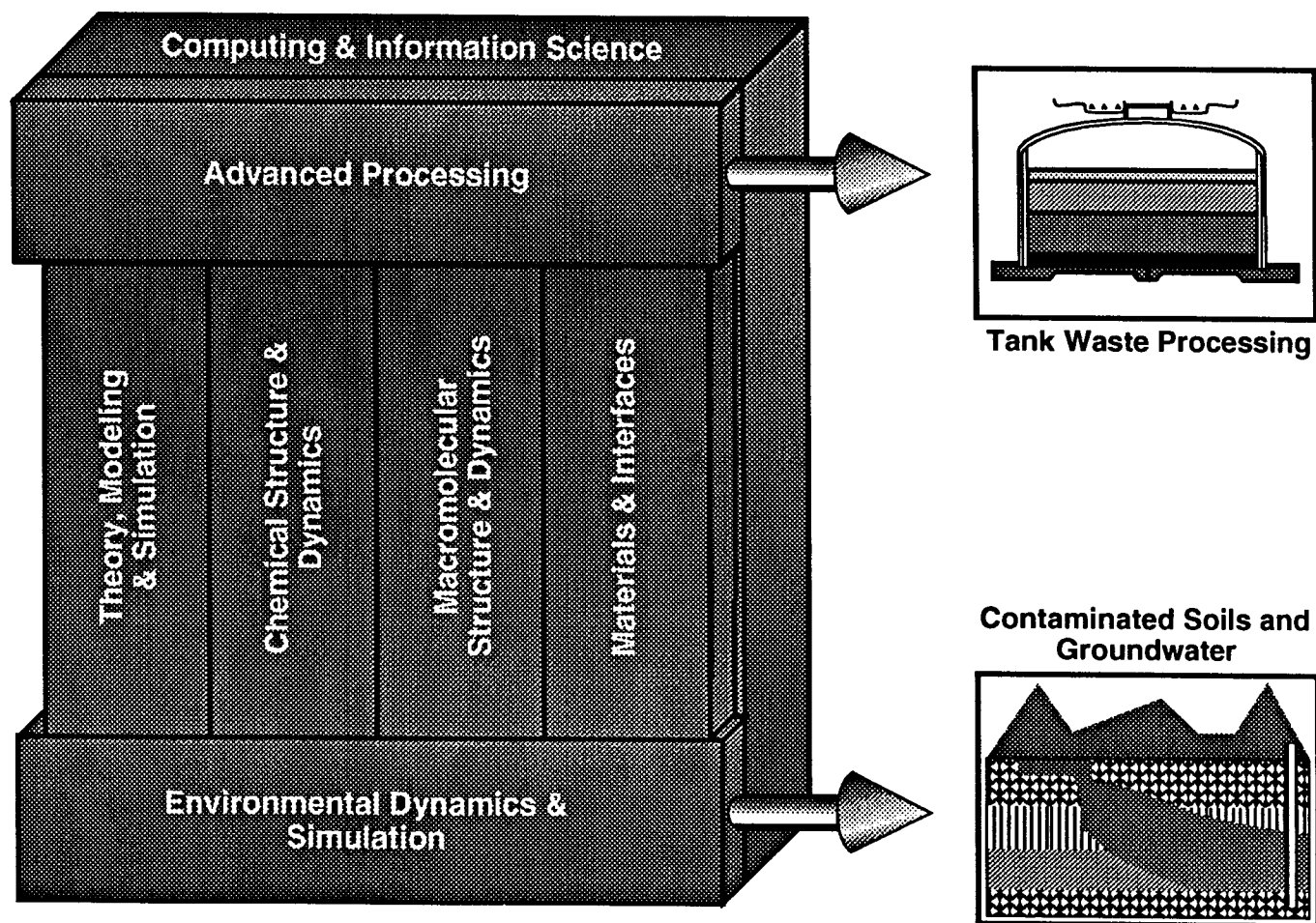

Figure 9-1. A multidisciplinary laboratory for Environmental Molecular Science.

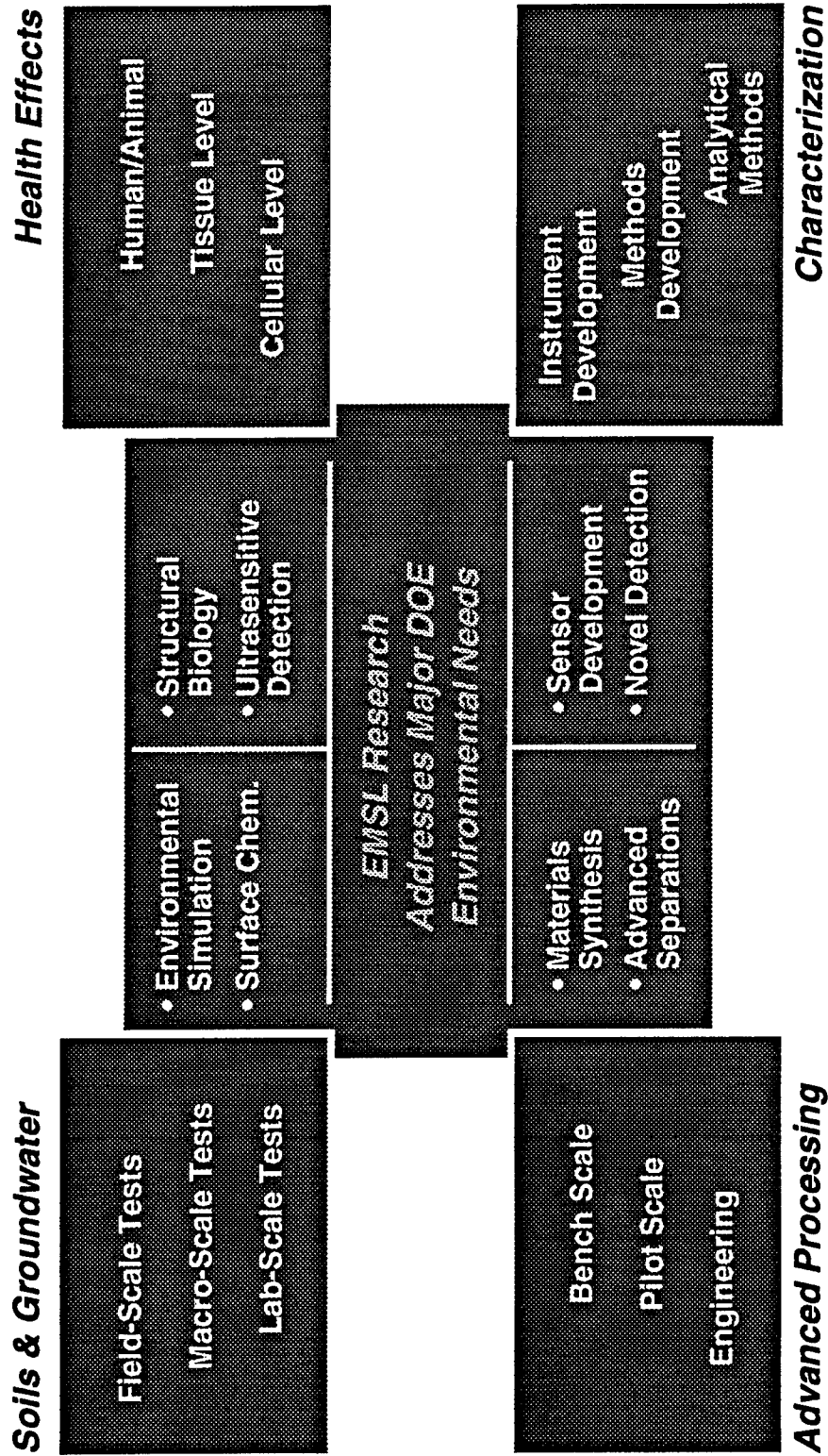

Figure 9-2.

cal Structures and Dynamics, Macromolecular Structure and Dynamics, and Materials and Interfaces, which are to transfer basic research results to two bridging programs, Environmental Dynamics and Simulation and Advanced Processing. The two bridging programs are expected to develop applications of the basic research results that can be used in the remediation efforts being carried out in other laboratories in PNL. As noted above, the organizational plan places an inadequate emphasis on microbiology, which has the potential for significantly improving remediation capabilities. To encourage necessary interdisciplinary work, microbiology should be added within the existing groups (perhaps with modifications of their present titles), rather than as a separate group. In addition, the EMSL does not yet appear to be functioning fully as envisioned in the present organizational charts, and we present below some suggestions as to how operations could be improved. Successful implementation of these suggestions will require managerial initiative to foster teamwork and coordinate research directions.

9.2 Advanced Processing

The Advanced Processing Group is primarily tasked with developing applications for the cleanup effort of tank wastes. In this problem, all the normal issues of chemical processing, such as materials transport, separation, and selective reaction are complicated by the nature of the mixed wastes that must be processed. The Advanced Processing Group appears to be well placed in awareness of the real problems involved in tank waste processing, and of the nature of the approaches that might be useful in dealing with the mixed wastes. However, the amount of input that it is receiving from the basic research groups on these problems appears to be limited. In some of the

sections below, we will comment on how this could be improved by efforts of the basic research groups. One serious omission in the efforts of the Advanced Processing Group is that there appears to be little or no effort in evaluating microbiological processes for toxic waste degradation. Such processes have been developed successfully in industrial applications, and should be tested for the difficult problems that must be addressed by PNL.

9.3 Environmental Dynamics and Simulation

The Environmental Dynamics and Simulation Group has developed a well focused program using the advanced computing capabilities of the model reactive chemical transport in contaminated soils and ground water. The group has developed active collaborations with the Subsurface Program, and should in time broaden the scope of its work to include bacterial transport. There does not yet seem to be much input from the basic research efforts within EMSL, which, as noted in earlier sections of this report and below, will be needed in developing simulations that provide realistic assessments of what is happening in the variable subsurface environment.

9.4 Theory, Modeling and Simulation

The Theory, Modeling and Simulation Group has developed capabilities to realize the long-held dream of molecular modeling to tailor materials to desired functions. The accomplishments of this group in developing the ability to calculate structure and function for complex molecules such as those in

zeolites are impressive. However, without follow-through to see that the calculations are tested experimentally, the work of this group cannot be useful to the overall mission of PNL. It is extremely surprising that there appears to be little or no correlated experimental work within the three experimental basic research groups to test the predictions of the calculations. The success of EMSL requires that systematic collaborations of theory and experiment be established to predict and test the properties of materials that are relevant to toxic waste separations and degradation. In this regard, the calculational efforts in rational enzyme design could have a significant positive impact in helping to develop microbiological processes for tank waste remediation, if it were coupled to correlated experimental studies. This group needs to place "Developing Real Collaborations with Experimentalists" at the top of its list of "Challenges."

9.5 Materials and Interfaces

Materials and interfaces are clearly of great importance in both the separations and catalysis required for tank remediation, and in the transport processes that must be understood for cleaning up ground contamination. The Materials and Interfaces Group has developed experimental capabilities that could be applied in both of these areas, and has begun to develop an effort focused on the mission of PNL. Immediate opportunities are open for such a focused effort in at least two areas. One would be in synthesis and characterization of the materials, such as zeolites and other catalysts, being studied by the Theory, Modeling and Simulation Group. Another would be in investigating the nature of adsorption and adhesion on the highly variable surface structures of the subsurface environment. The latter area of research

should include microbiological investigations as well as chemical studies. This work would be usefully addressed with scanned probe microscopies, as these techniques require neither a vacuum environment nor spatial homogeneity of the sample. Both of these areas of research require serious collaboration with the prospective users of the information generated in order to be useful.

9.6 Chemical Structures and Dynamics

The Chemical Structure and Dynamics Group has developed state-of-the-art capabilities in investigating reaction mechanisms and kinetics. The initial demonstrations of these capabilities have been performed on subjects that have general significance for remediation, but little or no direct connection has been made to other activities in EMSL or PNL even where the applications seem obvious, as with radiolytic reaction mechanisms. More rapid progress toward making such connections could be made by collaborating with the Theory and Modeling Group to test predictions made for both solid state and enzyme catalysts, and then to work with the Advanced Processing Group in transferring the most promising materials to the testing stage. Another area in which the capabilities of this laboratory could be applied is in state-of-the-art characterization of the structure and function of bacteria that may be used in bioremediation. It would be natural and effective to add microbiologists to the staff of the Chemical Structure and Dynamics Group to encourage such interdisciplinary work.

9.7 Macromolecular Structure and Dynamics

The Macromolecular Structure and Dynamics Group has developed and is continuing to develop state-of-the-art NMR capabilities for studying cellular and structural biology. They have developed collaborative interactions outside of EMSL involving assessment of health risks of exposure to toxic chemical and radiation. Similar collaborative efforts within EMSL should be directed at studies of enzyme-based degradation of toxic waste, and studies of structure and function of bacteria that might be used in bioremediation. The studies of enzyme function should be coordinated with the theoretical work of the Theory and Modeling Group, and with experimental studies in the other research groups of EMSL. They should be directed at transferring results to the Advanced Processing Group. For the studies of microbiology, it would be natural and effective to add microbiologists to the staff of the Macromolecular Structure and Dynamics Group, perhaps with joint membership in the Chemical Structure and Dynamics Group.

10 BIOREMEDIATION

10.1 The Long Haul

The program falls naturally, it appears, into at least two parts—those dealing with short-term scientific problems and those dealing with longer-term ones. The horizon for the short-term problems is optimistically set at about ten years. The longer ones may take virtually forever.

There is a substantial probability that there are genuine short-term scientific problems—that the distribution and heterogeneity of soil and subsoil types is terribly intricate and poorly structured taxonomically, that soil hydrology is terribly complex, that the transport of bacteria through subsoils is too varied a problem to effectively deal with, etc. Then there are also all the problems associated with the bacteria themselves: their metabolic activity in extreme environments, their tendency to adhere, etc.

These are the “short-term” problems. The long-term problems address the origins of life itself.

If there are no genuine short-term problems, where will the program find itself in 10 to 20 years? A great deal of scientific research will have been done, much of it, it is true, of broad interest and importance. But no scientific problem of central relevance to the problem of bioremediation will have been dented, much less solved, and certainly the whole group of problems that must be solved collectively according to the organizational goals of the program may hardly have been touched.

Is the program to be viewed, then, as a very long-term research undertaking which at some unspecified time far in the future may solve some of our pollution problems? Or are there relatively short-term and reasonable goals for the program by means of which some positive progress can be seen along the way?

Field tests at near or full scale seem appropriate. Useful experimental data will be of great significance to the long-term program not only as a guide along the way to validate predictions, but also as essential ingredients of the actual efforts at bioremediation.

Normally, near full-scale tests are inappropriate to a subject just barely in its infancy. But in this particular instance, the program must early on face the questions of licensing and making statements of environmental impact. If these cannot be overcome now at a purely harmless experimental level, how can they possibly be met when it is proposed to introduce living organisms in bulk into deep terrain, possibly organisms that have been genetically modified, and whose full range of possible appetites and mutants is hardly known—indeed it is never known. Moreover, the organisms will be operating far out of view and oversight.

The obvious large-scale experiments address, for example, questions of hydrology, diffusion and behavior of aquifers. We would suggest a large-scale and patient examination of diffusion of water in typical terrains, especially the types of terrains where remediation is obviously called for and perhaps even at the sites themselves. This will involve pumping water with tracers into the ground, and watching over a long period of time its arrival at locations at several scales of remoteness. This kind of experiment could probably be carried out at Hanford without upsetting anyone, and the data collected

will be of immense value. No experiment with glass beads in a laboratory setting will reveal the deep hydrology of a particular site as well as experiments at that site itself.

If it should come to pass that hydrology at some polluted site is comfortably understood, then appropriate nutrients and relatively benign (but effective) ordinary organisms might perhaps be introduced without much legal difficulty, though we wonder about this. One cannot help but recall the raging controversy about disposal of radioactive wastes in salt domes, though the temporal scale of this proposal is of altogether different magnitude, it is true.

Let us summarize, for emphasis, what we are driving at above. The bioremediation program is one of tasked pure research, or pure research with a mission. The general wisdom of science is, however, that such an effort cannot be managed on a schedule. Significant scientific results emerge in their own good time.

To give the bioremediation program a better transitional form, we think it desirable that large-scale field experiments, in anticipation of remedial progress and insights, be conducted with all vigor along the way.

References

- [1] Savage, D. C. and M. Fletcher, eds. (1985) *Bacterial Adhesion*. New York: Plenum Press.
- [2] Mozes, N., et al., eds. (1991) *Microbial Cell Surface Analysis*. New York: VCH Publishers, Inc.
- [3] Nir, S. (1976) Van der Waals Interactions Between Surfaces of Biological Interest, *Progress in Surface Science*, **8**, 1-58.
- [4] Lips, A. and N. Jessup (1979) Colloidal Aspects of Bacterial Adhesion, in: *Adhesion of Microorganisms to Surfaces*, D. Ellwood, J. Melling, and P. Rutter, eds., New York: Academic Press.
- [5] Hogg, R., T. Healy, and D. Fuerns Tenau (1966) *Trans. of the Faraday Soc.*, **62**, 1638.
- [6] Weise, G. and T. Healy (1970) [title??] *Trans. of the Faraday Soc.*, **66**, 490.
- [7] Wicken, A. (1985) Bacterial Cell Walls and Surfaces, in: *Bacterial Adhesion*, D. Savage and M. Fletcher, eds., New York: Plenum Press.
- [8] Dzyaloshinskii, I., E. Lifshitz, and L. Pitaevskii (1961) [title??] *Adv. Phys.*, **10**, 165.
- [9] Marshall, K., R. Stout, and R. Mitchell (1971) [title??] *J. Gen. Microbiol.*, **68**, 337.
- [10] Marshall, K. (1979) Mechanisms of Bacterial Adhesion at Solid Water Interfaces, in *Adhesion of Microorganisms to Surfaces*, D. Ellwood, J. Melling, and P. Rutter, eds., New York: Academic Press.

- [11] Yelloji-Rao, M. K. (1993) Bacterial Adhesion onto Apatatite Minerals-Electrokinetic Aspects, *Colloids and Surfaces A*, **79**, 293-300.
- [12] Stenstrom, T. A. (1989) Bacterial Hydrophobicity, an Overall Parameter for the Measurement of Adhesion Potential to Soil Particles, *Applied and Environmental Microbiology*, **55**, 142-147.
- [13] Bela, M. R. and R. R. Colwell (1982) Adsorption Kinetics of Laterally and Polarly Flagellated Vibrio, *Journal of Bacteriology*, **151**, 1568-1580.
- [14] Appelbaum, B. (1979) In Vitro Studies of Dental Plaque Formation: Absorption of Oral Streptococci to Hydroxyapatite, *Infection and Immunity*, **25**, 717-728.
- [15] Reif, F. (1965) *Fundamentals of Statistical and Thermal Physics*. New York: McGraw-Hill.
- [16] Lyklema, J. (1991) *Fundamentals of Interface and Colloid Science*. New York: Academic Press.
- [17] Israelachvili, J. N. (1992) Adhesion Forces Between Surfaces in Liquids and Condensable Vapours, *Surface Science Reports*, **14**, 109-160.
- [18] Godwin, S. L., M. Fletcher, and R. P. Curchard (1989) Interference Reflection Microscopic Study of Sites of Association between Gliding Bacteria and Glass Substrata, *Journal of Bacteriology*, **171**, 4589-4594.
- [19] Weber, G. and K. O. Greulich (1992) Manipulation of Cells, Organelles, and Genomes by Laser Microbeam and Optical Trap, *International Review of Cytology*, **133**, 1-40.
- [20] Sato, S., et al. (1991) Optical Trapping of Small Particles Using a 1.3 mm Compact InGaAsP Diode Laser, *Optics Letters*, **16**, 282-284.

- [21] Joyce, S. A. and J. E. Houston (1991) A New Force Sensor Incorporating Force-Feedback Control for Interfacial Force Microscopy, *Review of Scientific Instruments*, **62**, 710–714.
- [22] Quate, C. F. (1994) The Atomic Force Microscope as a Tool for Surface Imaging, *Surface Science*, **299/300**, 980.
- [23] See the recent review article by M. Sahimi, “Flow Phenomena in Rocks”, *Rev. Mod. Phys.*, **65**, 1393 (1993).
- [24] There have been a variety of attempts to work out bacterial transport and compare to laboratory experiments for specific cases of all these parameters. See for example B. Wood, C. Dawson, J. Szecsody and G. Streile, “Modeling Contaminant Transport and Biodegradation in a Layered Porous Media System”, *Water Res. Research*, **30**, 1893 (1994); D. E. Fontes, A. Mills, G. Hornberger and J. Herman, “Physical and Chemical Factors Influencing Transport of Micro-organism through Porous Media”, *App. and Env. Microbiology*, **57**, 2473 (1991); P. Sharma and M. McLerney, “Effect of Grain Size on Bacterial Penetration, Reproduction and Metabolic Activity in Porous Glass Bead Chambers”, *Appl. and Env. Microbiology*, **60**, 1481 (1994).
- [25] Taylor, G. I. (1953) *Proc. Roy. Soc. A* **219**, 186; R. Aris (1956) *Proc. Roy. Soc. A* **235**, 67.
- [26] Brenner, H. and L. J. Gaydes (1977) *J. Colloid and Interface Science* **58**, 213; H. Brenner (1980) *Physic-Chem. Hydrodynamics*, **1**, 91.
- [27] Sahimi, M. and V. L. Jue (1989) *Phys. Rev. Letter*, **62**, 629.
- [28] Prieve, D. ad P. M. Hoyson (1978) *J. Colloid and Interface Science*, **64**, 201.

- [29] See M. Sahimi and A. O. Imdakm (1991) *Phys. Rev. Lett.*, **66**, 1169 and references therein for a discussion of the problem. Here it states that for a pore size distribution of 18 μm (Ottawa Sandpack) the average roughness had λ near height. This seems to us to be a vast underestimate of the degree of roughness revealed by a variety of experiments. One possible approach to this problem is to use NMR relaxation as a way of determining the surface to volume ratio of the pore space (see papers cited in Sahimi, Reference [1]).
- [30] Koplik, J. S. Redner and D. Wilkinson (1991) *Phys. Rev. A*, **37**, 2619. We thank J. Koplik for graciously allowing us to use his existing computer program.
- [31] Lenske, R. and M. Travisano (1994) *Proc. National Acad. USA*, **91**, 6806.
- [32] See R. Lenormand in *Hydrodynamics of Dispersed Media*, J. P. Hulin, A. Cazabat, E. Guyon, and F. Carmona eds (Nork-Holland, 1990).
- [33] We are not alone in coming to the conclusion that adhesion can dramatically affect transport characteristics. See for example A. Camper, J. Hayes, P. J. Sturman, W. L. Jones and A. B. Cunningham (1993) "Effects of Motility and Adsorption Rate Coefficients on Transport of Bacteria through Saturated Porous Media", *Appl. and Env. Microbiology*, **59**, 3455.
- [34] The material in this section on metal processing is adapted wholesale from: Brierley, C. (1993) Opportunities for Innovation: Biotechnology (NIST GCR 93-633), R. Busche, ed.; Ehrlich, H., and C. Brierley (1990) *Microbial Mineral Recovery*. New York: McGraw-Hill, 303323; Macaskie, L. E. (1991) The Application of Biotechnology to the Treat-

- ment of Wastes Produced from the Nuclear Fuel Cycle, *Critical Reviews of Biotechnology*, **11**, 41–112.
- [35] Compliance with the National Environmental Policy Act Proposed Finding of No Significant Impact, Selection of Borosilicate Glass as the Defense Waste Processing Facility Waste Form for High-Level Radioactive Wastes, Savannah River Plant, Aiken, South Carolina (July 29, 1982), *Federal Register*, **47** (146) 32778–32783.
- [36] Disposal of Hanford Defense High-Level Transuranic and Tank Wastes, Hanford Site, Richland, Washington; Record of Decision (April 14, 1988), *Federal Register*, **53** (72) 12449–12453.
- [37] U.S. Department of Energy (1990) DOE White Paper: Evaluation and Selection of Borosilicate Glass as the Waste Form for Hanford High-Level Radioactive Waste. Washington, DC: U.S. Department of Energy.
- [38] Jostsons, A. (1994) Development of Synrock for HLW Management, in: *Proceedings of the Conference on Nuclear Power and Industry*, Obninne, Russia. 27 June–1 July, 1994, 1–7.
- [39] Lutze, W. and R. C. Ewing (1988) *Radioactive Waste Forms for the Future*. New York: North-Holland.
- [40] U.S. General Accounting Office (1992) Nuclear Waste. Defense Waste Processing Facility—Cost, Schedule, and Technical Issues. United States General Accounting Office Report to the Chairman, Environment, Energy, and Natural Resources Subcommittee, Committee on Government Operations, House of Representatives, GAO/RCED-92-183.
- [41] Reimus, M. A. H., G. F. Piepel, G. B. Mellinger, and L. R. Bunnell (1988) West Valley Glass Product Qualification Durability Studies, FY

1987–1988: Effects of Composition, Redox State, Thermal History, and Groundwater, PNL 6723. Richland, WA: Pacific Northwest Laboratories.

- [42] McCarthy, G., W. White, R. Roy, B. Scheetz, S. Komatheni, D. Smith and D. Roy (1978) Interactions between Nuclear Waste and Surrounding Rock, *Nature*, **273**, 216–217.
- [43] Ewing, R. C. and W. Lutze (1991) High-Level Waste Immobilization with Ceramics, *Ceramics International*, **17**, 287–293.
- [44] Ringwood, A., S. Kesson, K. Reeve, D. Levis and E. Ramm (1988) Synrock, in: *Radioactive Waste Forms for the Future*, W. Lutze and R. Ewing, eds. Amsterdam: North-Holland, 233–334.
- [45] Crocker, J.C. and Grier, D. G. (1994) Microscopic Measurement of the Pair Interaction Potential of Charge-Stabilized Colloid, *Physical Review Letters*, **73**, 352.

DISTRIBUTION LIST

Director of Space and SDI Programs
SAF/AQSC
1060 Air Force Pentagon
Washington, DC 20330-1060

CMDR & Program Executive Officer
U S Army/CSSD-ZA
Strategic Defense Command
PO Box 15280
Arlington, VA 22215-0150

A R P A Library
3701 North Fairfax Drive
Arlington, VA 22209-2308

Ms. Jill Banfield
University of Wisconsin-Madison
Geology & Geophysics
1215 W Dayton Street
Madison, WI 53706

Dr Arthur E Bisson
Director
Technology Directorate
Office of Naval Research
Room 407
800 N. Quincy Street
Arlington, VA 20350-1000

Dr Albert Brandenstein
Chief Scientist
Office of Nat'l Drug Control Policy
Executive Office of the President
Washington, DC 20500

Mr. Edward Brown
Assistant Director
ARPA/SISTO
3701 North Fairfax Drive
Arlington, VA 22203

Dr H Lee Buchanan, I I I
Director
ARPA/DSO
3701 North Fairfax Drive
Arlington, VA 22203-1714

Dr Ashton B Carter
Nuclear Security & Counter Proliferation
Office of the Secretary of Defense
The Pentagon, Room 4E821
Washington, DC 20301-2600

Dr Collier
Chief Scientist
U S Army Strategic Defense Command
PO Box 15280
Arlington, VA 22215-0280

DTIC [2]
Cameron Station
Alexandria, VA 22314

Mr John Darrah
Senior Scientist and Technical Advisor
HQAF SPACOM/CN
Peterson AFB, CO 80914-5001

Dr John M Deutch
Under Secretary
DOD, OUSD (Acquisition)
The Pentagon, Room 3E933
Washington, DC 20301

Dr Burt D Ensley
President, Phytotech, Inc
7 Colts Neck Drive
Newtown, PA 18940

Mr John N Entzminger
Chief, Advance Technology
ARPA/ASTO
3701 North Fairfax Drive
Arlington, VA 22203-1714

DISTRIBUTION LIST

Mr Dan Flynn [5]
OSWR
Central Intelligence Agency
Washington, DC 20505

Dr Paris Genalis
Deputy Director
OUSD(A&T)/S&TS/NW
The Pentagon, Room 3D1048
Washington, DC 20301

Dr Lawrence K. Gershwin
Central Intelligence Agency
NIC/NIO/S&T
7E47, OHB
Washington, DC 20505

Mr. Thomas H Handel
Office of Naval Intelligence
The Pentagon, Room 5D660
Washington, DC 20350-2000

Dr Robert G Henderson
Director
JASON Program Office
The MITRE Corporation
7525 Colshire Drive
Mailstop Z561
McLean, VA 22102

Dr Barry Horowitz
President and Chief Exec Officer
The MITRE Corporation
202 Burlington Road
Bedford, MA 01730-1420

Dr William E Howard III [2]
Director of Advanced Concepts &
Systems Design
The Pentagon Room 3E480
Washington, DC 20301-0103

Dr Gerald J Iafrate
U S Army Research Office
PO Box 12211
4330 South Miami Boulevard
Research Triangle NC 27709-2211

J A S O N Library [5]
The MITRE Corporation
Mail Stop W002
7525 Colshire Drive
McLean, VA 22102

Dr Anita Jones
Department of Defense
DOD, DDR&E
The Pentagon, Room 3E1014
Washington, DC 20301

Dr Bobby R Junker
Office of Naval Research
Code 111
800 North Quincy Street
Arlington, VA 22217

Lt Gen, Howard W. Leaf, (Retired)
Director, Test and Evaluation
HQ USAF/TE
1650 Air Force Pentagon
Washington, DC 20330-1650

Dr Herbert Levine
University of California/San Diego
Department of Physics
Mayer Hall, B019
La Jolla, CA 92093

Dr Alfred Lieberman
Chief Science Advisor, Acting
USACDA
320 21st Street NW
Washington, DC 20451

DISTRIBUTION LIST

Mr. Larry Lynn
Director
ARPA/DIRO
3701 North Fairfax Drive
Arlington, VA 22203-1714

Dr. John Lyons
Director of Corporate Laboratory
US Army Laboratory Command
2800 Powder Mill Road
Adelphi, MD 20783-1145

Dr Gordon J Mac Donald
IGCC
UCSD/0518
9500 Gilman Drive
La Jolla, CA 92093-0518

Col Ed Mahen
ARPA/DIRO
3701 North Fairfax Drive
Arlington, VA 22203-1714

Dr. Arthur Manfredi
OSWR
Central Intelligence Agency
Washington, DC 20505

Mr James J Mattice
Deputy Asst Secretary
(Research & Engineering)
SAF/AQ
Pentagon, Room 4D-977
Washington, DC 20330-1000

Dr Greg Moore [10]
Office of Research and Development
Central Intelligence Agency
Washington, DC 20505

Dr Bill Murphy
Central Intelligence Agency
ORD
Washington, DC 20505

Mr Ronald Murphy
ARPA/ASTO
3701 North Fairfax Drive
Arlington, VA 22203-1714

Dr Julian C Nall
Institute for Defense Analyses
1801 North Beauregard Street
Alexandria, VA 22311

Dr Ari Patrinos
Director
Environmental Sciences Division
ER74/GTN
US Department of Energy
Washington, DC 20585

Dr Bruce Pierce
USD(A)D S
The Pentagon, Room 3D136
Washington, DC 20301-3090

Dr William H Press
Harvard College Observatory
60 Garden Street
Cambridge, MA 02138

Mr John Rausch [2]
Division Head 06 Department
NAVOPINTCEN
4301 Suitland Road
Washington, DC 20390

Records Resource
The MITRE Corporation
Mailstop W115
7525 Colshire Drive
McLean, VA 22102

Dr Victor H Reis
US Department of Energy
DP-1, Room 4A019
1000 Independence Ave, SW
Washington, DC 20585

DISTRIBUTION LIST

Dr Malvin A Ruderman
29 Washington Square West
New York, NY 10011

Dr Fred E Saalfeld
Director
Office of Naval Research
800 North Quincy Street
Arlington, VA 22217-5000

Dr Dan Schuresko
O/DDS&T
Central Intelligence Agency
Washington, DC 20505

Dr John Schuster
Technical Director of Submarine
and SSBN Security Program
Department of the Navy OP-02T
The Pentagon Room 4D534
Washington, DC 20350-2000

Dr Michael A Stroschio
US Army Research Office
P. O. Box 12211
Research Triangle NC 27709-2211

Superintendent
Code 1424
Attn Documents Librarian
Naval Postgraduate School
Monterey, CA 93943

Dr Sam B Treiman
60 McCosh Circle
Princeton, NJ 08540

Dr George W Ullrich [3]
Deputy Director
Defense Nuclear Agency
6801 Telegraph Road
Alexandria, VA 22310

Dr Walter N Warnick [25]
Acting Director for Program Analysis
U S Department of Energy
ER30 / OER
Washington, DC 20585

Dr Edward C Whitman
Dep Assistant Secretary of the Navy
C3I Electronic Warfare & Space
Department of the Navy
The Pentagon 4D745
Washington, DC 20350-5000

Dr Ellen D Williams
Department of Physics & Astronomy
University of Maryland
College Park, MD d20742-4111

Capt H. A. Williams, U S N
Director Undersea Warfare Space
& Naval Warfare Sys Cmd
PD80
2451 Crystal Drive
Arlington, VA 22245-5200

Mr Charles A Zraket
Trustee
The MITRE Corporation
Mail Stop A130
202 Burlington Road
Bedford, MA 01730