

General Safety Information

WARNING – To avoid serious injuries:

- When installing the hub to the frame, be sure to install the correct non-turn washers to the left and right sides, and securely tighten the hub nuts to the specified torques. If the non-turn washers are installed to one side only, or if the hub nuts are not tightened sufficiently, the non-turn washer may fall out, which could cause the hub axle to rotate and the cassette joint to turn. This may then cause the handlebars to be accidentally pulled by the shifting cable, and an extremely serious accident could result.
- Obtain and read the service instructions carefully prior to installing the parts. Loose, worn, or damaged parts may cause serious injury to the rider. We strongly recommend only using genuine Shimano replacement parts.
- Check that the wheels are fastened securely before riding the bicycle. If the wheels are loose in any way, they may come off the bicycle and serious injury may result.
- Read these Technical Service Instructions carefully, and keep them in a safe place for later reference.

NOTE:

- You can shift gears while pedaling, but on rare occasions the pawls and ratchet inside the hub may produce some noise afterwards as part of normal gear shifting operation.
- The CJ-8S20 cassette joint should only be used with sprockets from 16T to 23T.
- If using a chain tensioner, use the special CS-S500 18T or 20T sprocket with chain guard. Do not use any other types of sprockets, otherwise the chain may come off the sprockets.
- If the wheel becomes stiff and difficult to turn, you should lubricate it with grease.
- You should periodically wash the sprockets in a neutral detergent and then lubricate them again. In addition, cleaning the chain with neutral detergent and lubricating it can be an effective way of extending the useful life of the sprockets and the chain.
- If the chain keeps coming off the sprockets during use, replace the sprockets and the chain.
- Parts are not guaranteed against natural wear or deterioration resulting from normal use.
- For maximum performance we highly recommend Shimano lubricants and maintenance products.
- For any questions regarding methods of handling or adjustment, please contact the place of purchase.

Installation of the CS-S500 sprocket with chain guard

- Install the chain guard to the right hand dust cap of the hub body, and then install right hand dust cap B to the driver.

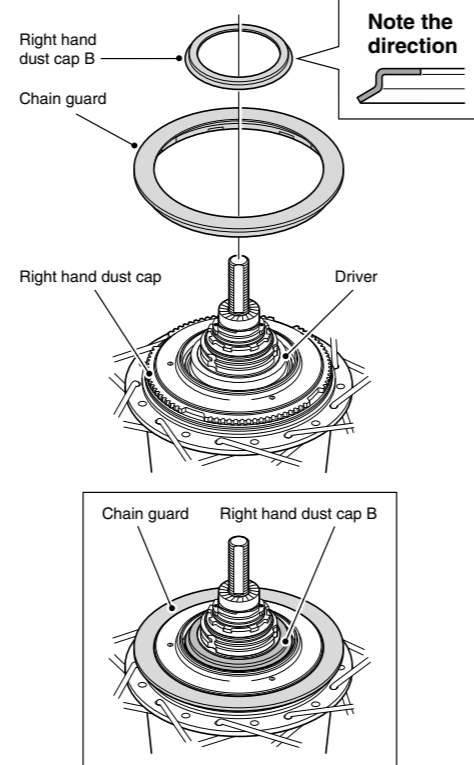

- Install the CS-S500 sprocket to the driver on the right side of the hub body with the guard plate facing outward, and secure it in place with the snap ring.

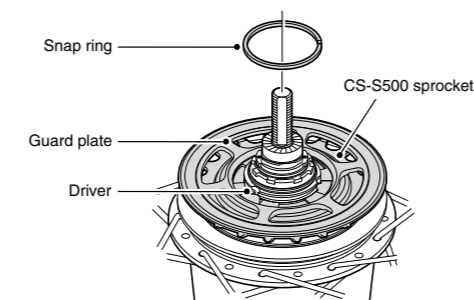

Installation of the cassette joint to the hub

- Install the driver cap to the driver on the right side of the hub body.

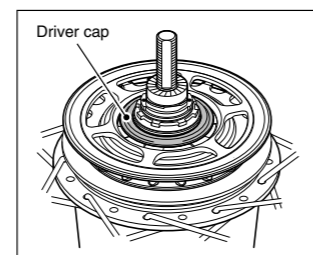
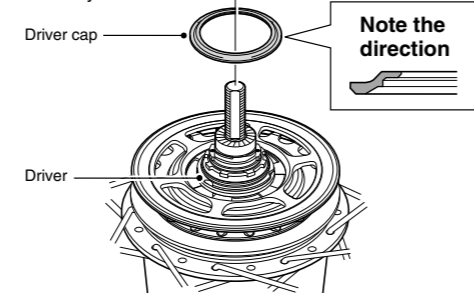

- Turn the cassette joint pulley in the direction of the arrow in the illustration to align the red ● marks on the pulley and the bracket. With the cassette joint in this condition, install it so that the red ● mark on the cassette joint is aligned with the red ● mark on the right side of the hub body.

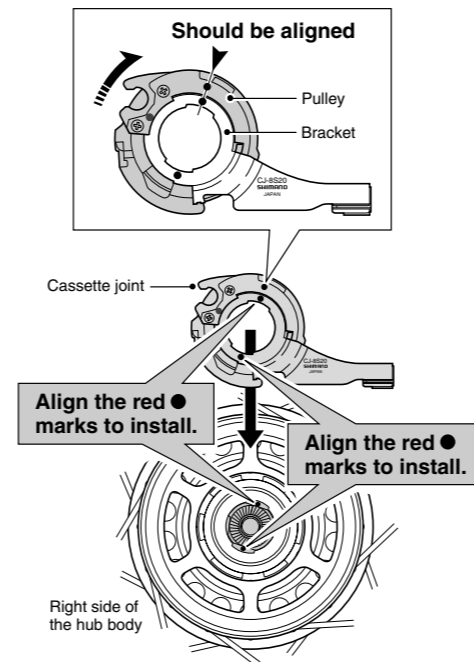

- Secure the cassette joint to the hub with the cassette joint fixing ring. When installing the cassette joint fixing ring, align the yellow ● mark with the yellow ● mark on the cassette joint pulley, and then turn the cassette joint fixing ring 45° clockwise.

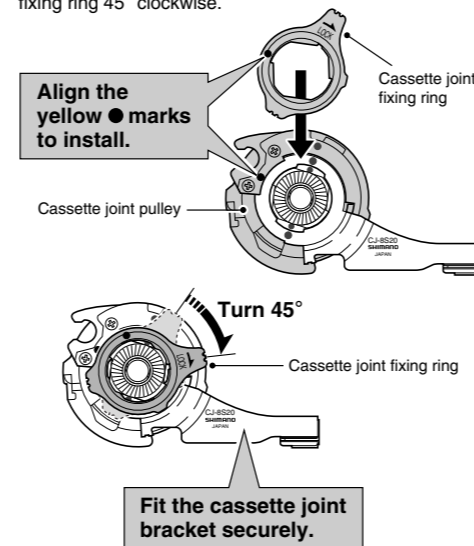

Installation of the hub to the frame

The method of installing the hub to the frame is the same when the chain tensioner is being used and when it is not being used.

- Mount the chain on the sprocket, and then set the hub axle into the dropouts.

When not using the chain tensioner

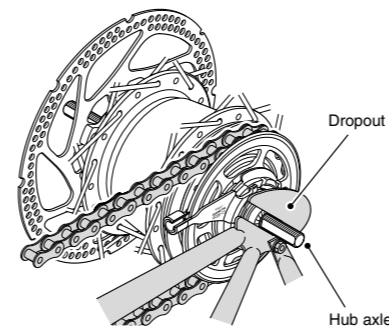

When using the chain tensioner

When using the chain tensioner, be sure to read these service instructions in conjunction with the service instructions for the CT-S500 chain tensioner.

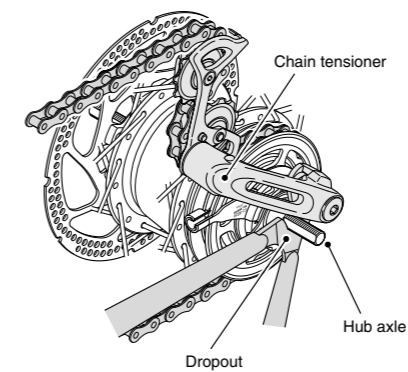

- Place the non-turn washers onto the right side and left side of the hub axle. At this time, turn the cassette joint so that the projecting parts of the non-turn washers fit into the grooves of the dropouts. If this is done, the cassette joint can be installed so that it is almost parallel to the chainstay.

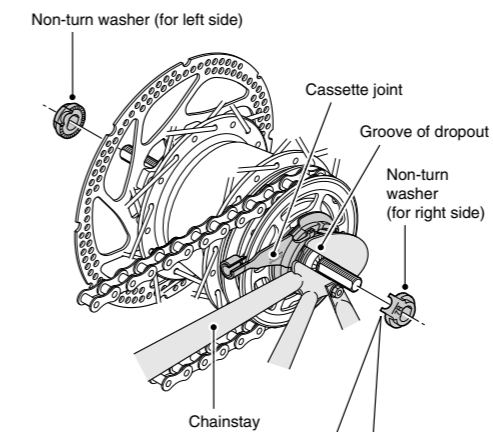

- Use whichever non-turn washers match the shape of the dropouts. Different non-turn washers are used at the left and right sides.

Dropouts	Non-turn washer		Size
	Right	Left	
Standard	5R/Yellow	5L/Brown	$\theta \leq 20^\circ$
	7R/Black	7L/Gray	$\theta \leq 38^\circ$
Reversed	6R/Silver	6L/White	$\theta = 0^\circ$
Reversed (full chain case)	5R/Yellow	5L/Brown	$\theta = 0^\circ$
Vertical	8R/Blue	8L/Green	$\theta = 60^\circ - 90^\circ$

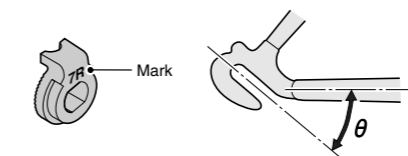

- The projecting parts should be on the dropouts side.
- Install the non-turn washers so that the projecting parts is securely in the dropouts grooves on either side of the hub axle.

- Take up the slack in the chain and secure the wheel to the frame with the cap nuts.

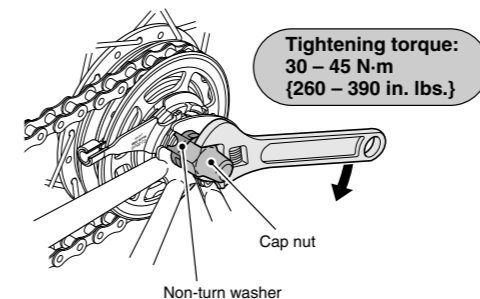

Note:

When installing a part such as a mudguard stay to the hub axle, install in the order shown in the illustration below.

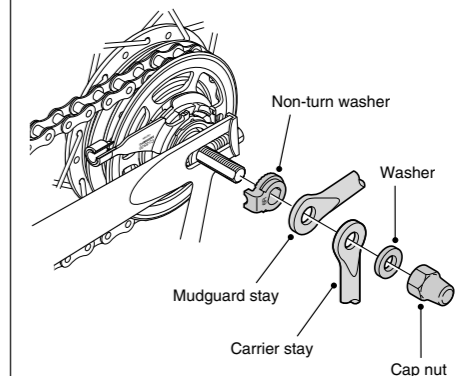

Note:

When installing the hub to the frame, the chain guard may come off, so check that the chain guard is securely installed so that it will not come off. If it is not fully installed, noise may be generated.

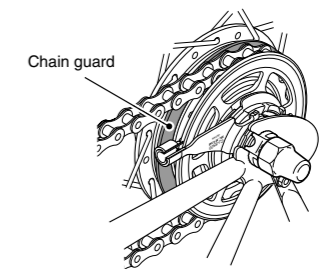

Installation of the rotor

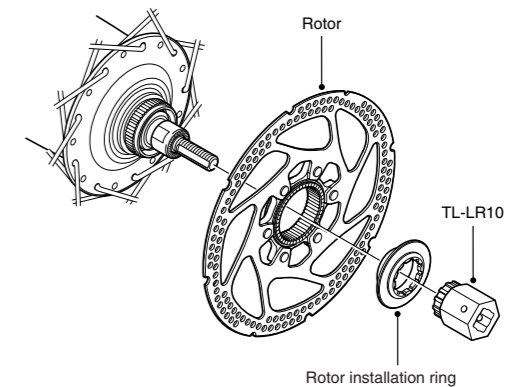

Tightening torque:
40 N·m {347 in. lbs.}

These service instructions explain how to use and maintain the Shimano bicycle parts which have been used on your new bicycle. For any questions regarding your bicycle or other matters which are not related to Shimano parts, please contact the place of purchase or the bicycle manufacturer.

These service instructions are printed on recycled paper.

Please note: Specifications are subject to change for improvement without notice. (English)

SHIMANO

SHIMANO AMERICAN CORPORATION

One Holland, Irvine, California 92618, U.S.A. Phone: +1-949-951-5003

SHIMANO EUROPE B.V.

Industrieweg 24, 8071 CT Nunspeet, The Netherlands Phone: +31-341-272222

SHIMANO INC.

3-77 Oimatsu-cho, Sakai-ku, Sakai, Osaka 590-8577, Japan

© Feb. 2007 by Shimano Inc. P.I.T. SZK. Printed in Japan

SI-3520C-001

SG-S500
CS-S500
CJ-8S20

Hub for Inter-8
Disc Brake
Sprocket with
Chain Guard
Cassette joint

Technical Service Instructions

SHIMANO
ALFINE

Be sure to read these service instructions in conjunction with the service instructions for the brake and the shifting lever before use.