

THE INVENTION OF THE CAVITY MAGNETRON AND ITS INTRODUCTION INTO CANADA AND THE U.S.A.

by Paul A. Redhead

James P. Baxter, the official U.S. historian of scientific developments in the second world war, said of the first cavity magnetron brought from the UK to North America^[1]:

When the members of the Tizard Mission brought one to America in 1940, they carried the most valuable cargo ever brought to our shores. It sparked the whole development of microwave radar and constituted the most important item in reverse Lend-Lease.

INTRODUCTION

By the start of the war in 1939 the British had a chain of operating radar stations around the South and East coasts of Britain which were capable of detecting aircraft at 15,000 feet out to a range of about 150 miles; this system operated at a wavelength of 10 to 13 metres (23 to 30 MHz). Airborne radar was also being tested at a wavelength of 1.5 metres (200 MHz). It had been appreciated for some time that shorter wavelengths would have considerable advantages for radar; however, both the transmitted power and the receiver sensitivity of equipment available at the time decreased rapidly for wavelengths less than about 1.5 meters.

In the summer of 1939 Professor John D. Cockcroft of the Physics Department at Cambridge University and Professor Mark L. Oliphant of the Physics Department at the University of Birmingham were brought into the British radar program (which was classified Top Secret) and they both became proponents for the development of components that would make microwave radar possible. This course had been repeatedly urged by E.G. Bowen, and the other scientists working on airborne radar, to reduce the problem of ground return echoes. This problem arose with long wavelength radar because the antennas could not be made highly directional, as a result the strong radar echo from the ground obscured the weak echo from an aircraft beyond a certain range. Oliphant strongly recommended that an oscillator tube should be developed to give a peak power of about 1kW at 10 cm wavelength. There were three main advantages to be gained from going to wavelengths of 10 cm or less

(known as microwaves), 1) the resolution of the radar images would be much improved; 2) the radar equipment, and particularly the antenna system, would be smaller, permitting easier installation on aircraft and naval vessels; and 3) since a microwave antenna could be made highly directional, the limitation to the range of airborne radars, as a result of echoes from the ground, would no longer be a problem^[2]. Soon after the war started in 1939, the Committee on Valve Development (CVD) of the British Admiralty (which was responsible for coordinating the development of electron tubes for the three services) placed two research contracts for the development of vacuum tubes for 10 cm wavelength (3GHz) with the

Physics Department at Birmingham University for transmitting tubes, and with the Clarendon laboratories at Oxford University for receiving tubes. It was at Birmingham that the multicavity magnetron was invented.

Canada became involved in radar in March of 1939 when the British Air Ministry decided to inform the Dominion governments, under the seal of secrecy, of the progress of radar development in Britain. John T. Henderson, the head of the Radio Section of the Division of Physics and Electrical Engineering at the National Research Council (NRC), was chosen to represent Canada at these meetings in London where he was joined by Squadron Leader F.V. Heakes, the Liaison Officer for the RCAF in the UK; they produced two reports on the information obtained in the UK^[3]. The importance of radar for the war looming ahead was recognized by the President of NRC (General A.G.L. McNaughton) who requested \$105,000 from the Mackenzie King government to pursue radar research, but were refused. In the fiscal year starting April 1st 1939 the NRC managed to transfer less than \$6,000 from other resources, and four persons were seconded from the Department of National Defence to the NRC radar

P.A. Redhead (redhead@magma.ca), Researcher Emeritus, National Research Council, Ottawa, ON K1A 0R6.

program. Thus, when the war started, the British effort in radar was considerable and radar had been accepted as first priority for scientific activity while, in Canada, radar work was minimal (the Radio Section at NRC then had only five scientists) and the government showed no interest in supporting research.

INVENTION OF THE MULTICAVITY MAGNETRON

The magnetron, a vacuum tube with a cylindrical anode surrounding an axial thermionic cathode with a magnetic field directed along the axis, was first demonstrated to produce radio frequency oscillations in 1921 by A.W. Hull at the General Electric Laboratories in Schenectady, New York^[4]. By 1925 Elder at G.E. was able to produce an output of 8 kW at 30 kHz with an efficiency of 69%^[5]. During the next 15 years there was considerable research on magnetrons in many countries; this work has been well summarized by Swords^[6]. These early magnetrons tended to be erratic in their oscillatory behaviour, had many different modes of oscillation, and the output power and efficiency were low. In 1935 Posthumus^[7] demonstrated that, if travelling wave conditions were fulfilled, *i.e.* the electron cloud rotated about the cathode in synchronism with the radio-frequency field, then considerable efficiencies were observed. The work of Posthumus led to a much clearer theoretical understanding of the operation of the magnetron. The

travelling wave mode of operation of the magnetron proved the most effective in practice, with good efficiency, moderate requirements for magnetic field, and stability of operation. Figure 1 illustrates the structures of various types of early magnetrons^[8], prior to the invention of the multicavity magnetron. The segmented-anode magnetron [(e) in Fig. 1] was a low efficiency oscillator about which several hundred papers were published between 1924 and 1940^[9].

A.L. Samuel of the Bell Telephone Laboratories filed a patent in 1934^[10] describing a magnetron (see Figure 2) with a four cavity anode. The anode in this design was effectively part of the vacuum envelope but the magnetic field had to be provided by a solenoid and thus only low magnetic fields were practical.

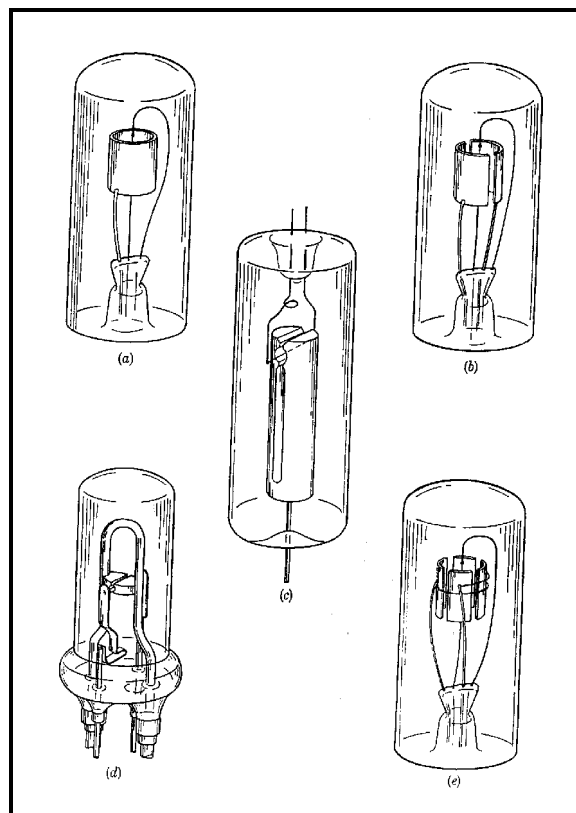

Fig. 1 Structure of early magnetrons; a) original Hull diode; b) split anode; c) split anode with internal resonator; d) improved split anode; e) four segment anode.

This appears to have been the first multicavity magnetron.

The first successful multicavity magnetron design suitable for the generation of significant amounts of microwave power was developed in Russia by Aleksereff and Malearoff^[11] in 1936-37 and the results were first published in 1940. Figure 3 shows schematically a four-cavity version of this device, the anode was made from a solid copper block which was water cooled and was suspended inside a continuously evacuated chamber. Continuous power of about 300 watts at a wavelength of 10 cm, and an efficiency of about 20%, was obtained with this four-cavity tube. This promising magnetron does not appear to have been used in any Soviet radar system. This Russian work was not known outside Russia until after the invention of the multicavity microwave with an external anode by Randall and Boot in late 1939. In the Randall and Boot design the anode was part of the vacuum envelope and hence "external" to the vacuum region, as contrasted with earlier designs where the anode was within a glass envelope. The advantage of the external anode was twofold: the magnet gap could be reduced, and cooling the anode was easier.

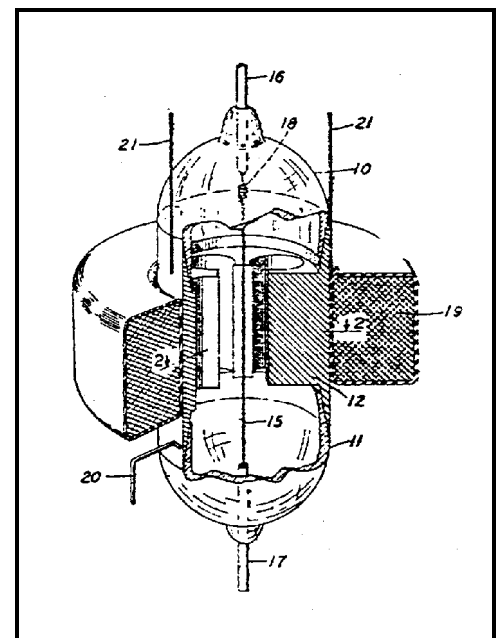

Fig. 2 Four-cavity magnetron developed by A.L. Samuel at the Bell Telephone Laboratories in 1934. The anode (12) was inserted into a thin-walled copper tube, a thoriated tungsten filament (15) was supported axially by tungsten rods (16, 17) sealed into glass domes (10, 11) which were then sealed to the ends of the copper tube. The magnetic field was provided by a solenoid (19).

In Japan, research on magnetrons started in the 1920's. K. Okabe^[12] working with H. Yagi at the Tohoku College of Engineering developed a split-anode magnetron in 1927 [(b) in Fig. 1], its lowest operating wavelength was 12 cm^[13]. In 1933 a coordinated program of magnetron research between the Japanese Navy and the Japan Radio Company was started and, by 1939, the Japan Radio Company had developed an 8-cavity, water-cooled magnetron at a wavelength of 10 cm with a continuous output power of 500 W. The water-cooled anode block was inside a glass envelope. Cavity magnetrons with wavelengths as short as 7 mm were later produced. In 1941 JRC produced a prototype cavity magnetron at 10 cm wavelength using a permanent magnet, this magnetron was an all-metal design, *i.e.* the anode was part of the vacuum envelope and water cooled. This design was very similar to the first cavity magnetrons manufactured in the UK except that it was water cooled rather than air cooled; this Japanese magnetron was not manufactured in any quantity because of a shortage of material for the permanent magnet and of manufacturing facilities^[14].

In Germany there was considerable research on magnetrons prior to 1939 but there was no work on cavity magnetrons. German radar equipment was highly developed by 1939 but did not have a high power microwave source. The Germans were astonished by the microwave cavity magnetron in a British 10 cm airborne radar found in a crashed bomber in 1943.

Shortly after the war started, the Birmingham University group under Oliphant concentrated on the development of high power klystrons as microwave generators. The klystron is a microwave tube where an electron beam is passed through one or more resonant cavities, it does not need a magnetic field for its operation. The klystron had been recently invented in the USA by the Varian brothers at Stanford University^[15] and had been seen by Oliphant during a visit to the United States in 1938. John T. Randall joined Oliphant's group in 1937 after working for some years at the General Electric Company in Wembley in North London; he was 34 in 1940. Henry A.H. Boot was one of six post-graduate students in physics in 1939; he was 22 in 1940. A fortnight before the war started in 1939, Oliphant's group all went to the CH (Chain Home) radar station, at Ventnor in the Isle of Wight, to become familiar with the existing radar equipment.

On September 3rd, when war was declared, all the senior staff, including Randall, returned to Birmingham, leaving Boot and another student at Ventnor. After six weeks they also returned to Birmingham. In a 1977 interview Boot remembered that when he arrived back in Birmingham ...*the team had already been arranged and was already working on klystrons, either high-power or receiving (amplifier) klystrons... Randall wasn't doing anything much then, and I came back and I wasn't doing anything much. And we were just put together. They said 'you work with him'. That suited me very well, because we got on perfectly.* They started work on Barkhausen-Kurtz detectors; however, they had no microwave generator with which to test their B-K detectors so they turned their thoughts to the development of a magnetron for this purpose -- *at the risk of incurring some unpopularity from our fellow workers, we concentrated our thoughts on how we could combine the advantages of the klystron with what we believed to be the more favourable geometry of the magnetron*^[16]. In an afternoon's discussion in November 1939 Randall and Boot hammered out the basic design of the multicavity magnetron; the type of cavity resonator, the number of cavities, and the form of the output circuit were all decided. Because of the lack of facilities at this early stage of the project, and the move to a new laboratory building, the first experimental tube was not ready until February 21st, 1940, but then it created an extraordinary impression by producing so much power that corona discharges appeared in the air at the output terminal. It

was soon established that the magnetron was producing 400W of continuous power at a wavelength of 9.8 cm. The experimental tube (see Figure 4) had six cavities in the anode block and, because an oxide cathode was thought to be too complex for a prototype, a 0.75 mm diameter tungsten filament was used as the cathode, the tube was continuously pumped and the glass-metal joints closed with sealing wax.

There is no doubt that Randall and Boot invented the cavity magnetron, but they were not the first to do so; they were preceded, as mentioned above, by the work of Samuel in the USA, Aleksereff and Malaroff in Russia, and the Japanese work. Randall and Boot were almost certainly unaware of this prior work; however, the Randall and Boot design, with the anode being part of the vacuum envelope and the output coupling loop inside a cavity, made the high-power cavity magnetron possible; this design was the basis of

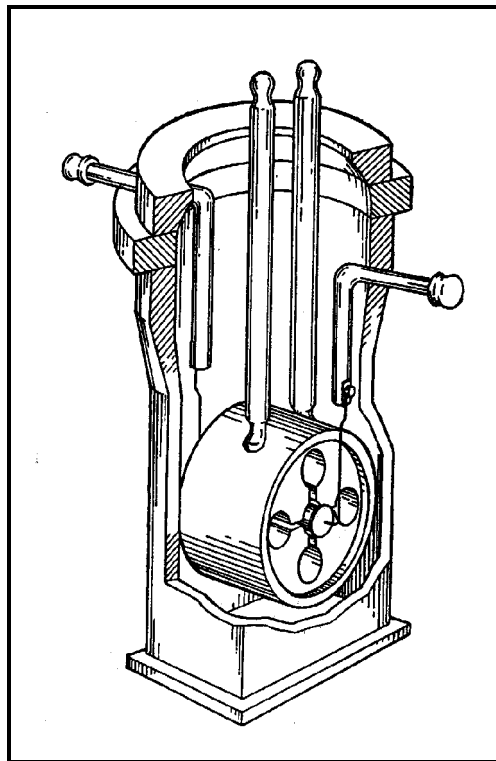

Fig. 3 The magnetron with four *internal* cavities developed by Aleksereff and Malaroff in 1936-7.

all further microwave magnetron design. This development was to revolutionize radar and was the key element in making microwave radar possible. Figure 5 shows Randall and Boot in their laboratory after the war; Boot is holding the anode block of a six-cavity magnetron and Randall is holding a "Sutton tube", a 10 cm wavelength reflex klystron used as a local oscillator in the microwave receiver, which was developed by Robert Sutton at the Admiralty Signals Establishment in Portsmouth, the first successful prototype operated in July 1940. The cavity magnetron and the reflex klystron made the first microwave radar systems possible .

On July 27th 1940 the Birmingham group had produced a magnetron giving substantial power at 5 cm wavelength. By September they had successfully tested a 14-cavity tube at 5 cm, a 6-cavity tube at 3 cm, and a magnetron at 2 cm with a 30-slot anode. By May 1941, a 10 cm magnetron producing over a megawatt of peak power was developed. See the article by Boot and Randall^[17] for a more detailed account of the early work at Birmingham University.

In April 1940 the research laboratories of the General Electric Company Ltd. (GEC) at Wembley, in North London, were contracted by the C.V.D. to design and manufacture sealed-off versions of the Randall and Boot magnetron. Two successful sealed-off tubes were produced by June 1940, one with a thoriated-tungsten filament and the other with an oxide-coated cathode. Tube No. 1 was water cooled and, by June 29th, tube oscillated with a pulsed output of about 500W average power at 9.8 cm. The later tubes were all air cooled.

E.C.S. Megaw, the leader of the group at the GEC laboratories, made two very significant changes to the original Randall and Boot design, which had

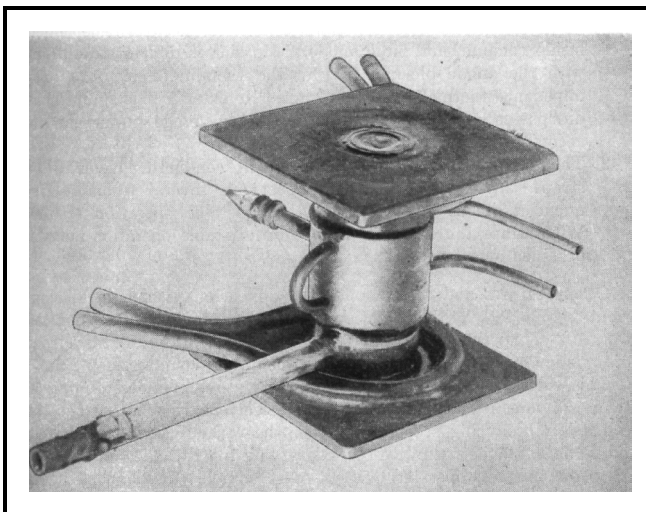

Fig. 4 Randall and Boot's first experimental magnetron. The anode had six cavities and was water cooled, the tube was continuously pumped and placed between the poles of an electromagnet.

profound effects on developing the magnetron's full potential. The first change was to pulse the tube at very high voltages, and the second was to increase the diameter of the cathode and to use oxide-coated cathodes. It had previously been thought that oxide cathodes would not withstand the back-bombardment of the cathode by energetic electrons that occurs in an operating magnetron. On May 8th, 1940, M. Ponte, from the laboratories of the Compagnie Générale de Télégraphie Sans Fil in Paris, brought to the GEC laboratories at Wembley a resonant segment magnetron designed by H. Gutton of SFR in Paris for pulsed operation at a wavelength of 16 cm. This tube used a large oxide-coated cathode and gave a pulsed power output of 1kW, demonstrating that oxide cathodes were suitable for magnetrons. The French work had demonstrated that oxide cathodes could withstand the back-bombardment by electrons and, because of the cathode's high secondary emission yield, it could deliver very large anode currents. A 6 mm diameter oxide-coated cathode was installed in tube No. 2 at GEC and, by July 1st, was giving 5kW peak power. An urgent demand for further samples came from the radar development

laboratories and several copies of No. 2 were made, using the chamber of a Colt revolver - which just happened to be the right size - as a drilling jig. By August 1940 tube No. 12, which was the first of a revised design with 8 rather than 6 cavities, was tested and produced about 10kW. It was this tube that was handed to the Tizard mission and brought to North America. Figure 6 is a diagram showing the construction of this magnetron. Figure 7 is a photograph of the magnetron brought to North America by the Tizard mission which is now on display at the National Museum of Science and Technology in Ottawa.



Fig. 5 Dr Henry Albert Howard Boot and Sir John Turton Randall in their laboratory after the war. Boot is holding the anode block of a six cavity magnetron and Randall holds a reflex klystron at 10 cm wavelength known as a "Sutton tube".

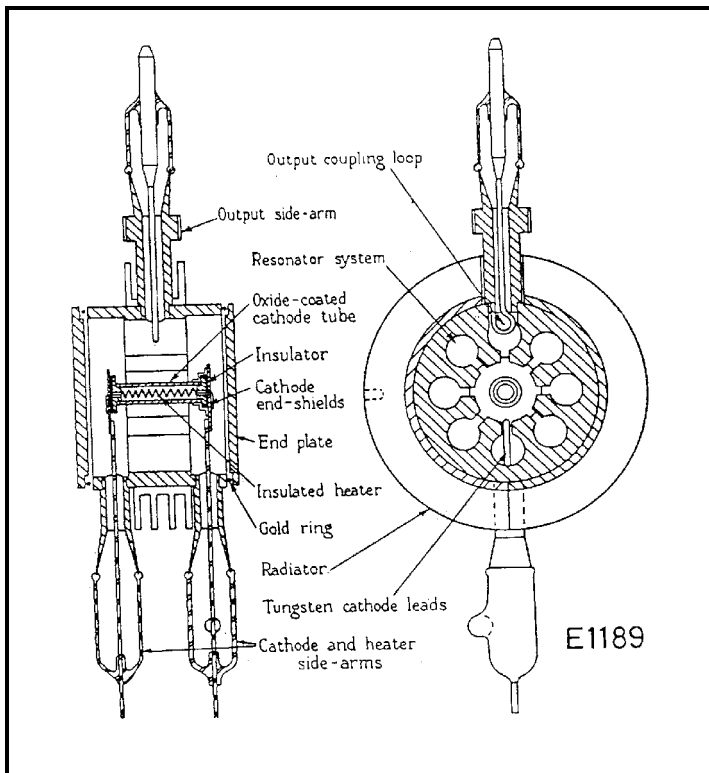

Fig. 6 Diagram of the magnetron brought to North America by the Tizard Mission in 1940. Type E1189.

By September 1940, outputs of as much as 100 kW peak power were being produced at 10 cm wavelength by magnetrons from GEC. In late 1940 the British Thomson-Houston Co. joined GEC in manufacturing magnetrons. By the end of 1941 the two companies had produced 2,000 magnetrons (types NT98 and CV38).

Oliphant set up a magnetron production unit at Birmingham and between 1941 and 1943 about 1,000 tubes were manufactured. John Sayers measured the frequency distribution of the oscillating modes of an 8-cavity magnetron and found that increased frequency separation could be achieved by interconnecting alternate segments. Six "strapped" tubes were manufactured in the production unit in September 1941. A considerable increase in efficiency was observed (e.g. at 0.2 Tesla the unstrapped tube [NT 98] had an efficiency of 12% whereas the strapped tube [CV 76] was 55% efficient) and had improved stability. The strapping process was of major importance and Oliphant, who was in the USA at the time, informed the Americans and Canadians who immediately applied strapping to all their magnetrons in production. See the article by

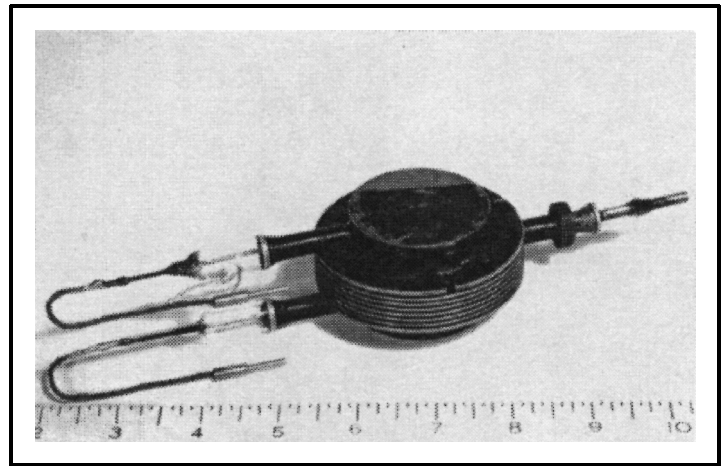

Fig. 7 The multicavity, microwave magnetron brought to North America by the Tizard Mission in 1940 (E1189 Serial No. 12); the seed from which microwave radar grew.

E.C.S. Megaw^[18] and E.B. Callick's book^[19] for more detailed accounts of this early work in the U.K.

THE TIZARD MISSION COMES TO NORTH AMERICA

Early in 1940 Sir Henry Tizard (see Figure 8) suggested that Britain should disclose its scientific secrets on military matters to the USA and Canada in exchange for desperately needed assistance in technology and production. Tizard was Rector of the Imperial College of Science and Technology in London and had been chairman of the Committee for the Scientific Survey of Air Defence since its formation in 1935; this committee had been largely responsible for starting and promoting the work on radar in the UK. In 1939 Tizard was the chief scientific advisor to the Air Ministry and was a central figure in organizing science for the British war effort. The proposal for an exchange of information with the USA and Canada was the subject of intense debate after Churchill became prime minister in May 1940. The resulting maneuvers, both bureau-crat and political, at this highly critical time just after the fall of France now appear quite extraordinarily short sighted. This sorry situation is well described in Zimmerman's *Top Secret Exchange*. Churchill gave final approval on August 9th for a mission headed by Tizard to go to Canada and the USA. The Tizard Mission consisted of

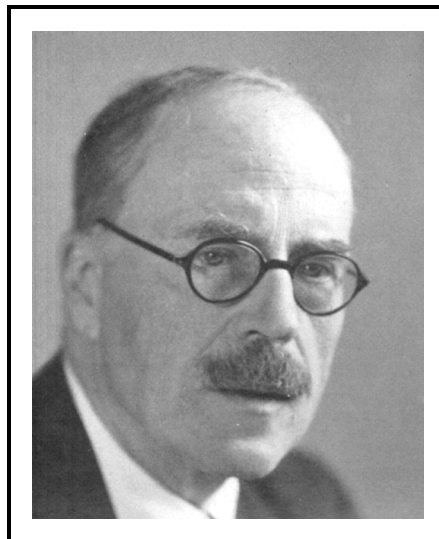

Fig. 8 Sir Henry Tizard.

Sir Henry Tizard (Mission Leader)
Brigadier F.C. Wallace (Army)
Captain H.C. Faulkner (Navy)
Group Captain F.L. Pearce (RAF)

Professor John Cockcroft (Army Research)
E.G. Bowen (Radar)
A.E. Woodward Nutt (Secretary)

Bowen and Cockcroft were the technical experts on radar. Documentation on radar and other secret military projects, such as manuals, circuit diagrams, blueprints and films, were assembled and placed in a black, metal deed box. By far the most important item in the black box was E1189 serial number 12, the experimental magnetron from GEC. Tizard and Pearce left England on the flying boat *Clair* bound for Montreal via Northern Ireland and Newfoundland on the 14th of August. The rest of the mission sailed from Liverpool on the 28th, with the carefully guarded black box, aboard the *Duchess of Richmond* bound for Halifax together with more than a thousand men of the Royal Navy going to man the 50 antiquated (and largely obsolete) destroyers recently provided to the UK by the USA in exchange for bases in Bermuda and elsewhere.

Tizard and Pearce arrived in Ottawa on the 15th of August and spent the 16th in discussions with C.J. MacKenzie, the acting president of the National Research Council, and other officials. MacKenzie was acting president in the absence of the President, General MacNaughton, who had left for military duty the day war was declared. The day ended in dinner with the Prime Minister at Mackenzie King's estate at Kingsmere in the Gatineau Hills north of Ottawa. Tizard's reaction to this strange personality amongst his imitation ruins was understandably one of surprise. King promised to speak to Roosevelt about the mission when they met the next day, there is no record that he did so, nor did King make any commitment to increase the involvement of Canada in the scientific war effort. During the next three days Tizard and Pearce assessed the Canadian research effort and potential. MacKenzie introduced Tizard to many persons in politics, the armed services and universities. MacKenzie and Tizard became intimate friends and maintained a close relationship. Tizard, realizing the good he could do in furthering the embryonic research effort in Canada, returned to Ottawa on August 26, after a brief visit to Washington.

Tizard and Pearce arrived in Washington by train on the 22nd of August and established the mission's headquarters in the British embassy with the help of MacKenzie who lent him two secretaries from his own office at the National Research Council (Doreen Geary and Vera King), since the British government had omitted to provide Tizard with any facilities. The rest of the Mission arrived in Halifax on September 6th. Bowen and Cockcroft went on to Ottawa to decide details with the NRC; the others went directly to Washington to join Tizard and Pearce, where they were joined by Bowen and

Cockcroft on September 11th. The black box was taken directly to Washington.

The official meetings of the Mission with the Americans started on the 10th of September. MacKenzie arrived in Washington on the 12th and, together with representatives of the Canadian army and the RCAF, joined in the meetings. J.T. Henderson, the most knowledgeable scientist at NRC on radar, also joined the meetings on the 16th. Several other Canadian scientists and military experts joined the meetings of the mission with the Americans.

The mission, in whole or in part, visited laboratories in many parts of the USA. Bowen has noted^[20] that -- *During the first few weeks of the Mission the existence of the resonant magnetron had been hinted at but not described. After examining the American work at 10 cm wavelength, the magnetron was first disclosed to the Americans on September 19th at the Washington apartment of Alfred Loomis, who was the recently appointed chairman of the Microwave Committee of the National Defence Research Committee. At this session were Cockcroft, Bowen, and J.T. Henderson who were meeting with the Americans Alfred Loomis, Karl Compton, Admiral Bowen and Carol Wilson. Bowen again -- However, there was nothing, even in embryo, which matched the British resonant magnetron. We quietly produced the magnetron and those present at the meeting were shaken to learn that it could produce a full 10 kilowatts of pulsed power at a wavelength of 10 centimeters. This was the first time that the secret of the cavity magnetron was exposed to Canadians and Americans.*

Over the weekend of 28-29 September, the key meeting with Loomis occurred at his home in Tuxedo Park. At this meeting Cockcroft and Bowen met with Loomis, Wilson, Edward Bowles from the Massachusetts Institute of Technology, Hugh Willis, the director of research at Sperry Gyroscope, Charles Lauritsen of the California Institute of Technology, and J.W. Bell from NRC. Bowen again -- *That evening we produced the magnetron once again, together with the drawings and construction details. The atmosphere was electric -- they found it hard to believe that such a small device could produce so much power and that what lay on the table in front of us might prove to be the salvation of the Allied cause. It was agreed that, if the magnetron worked as claimed, the Microwave Committee would immediately contract with Bell Telephone Laboratories to make copies. The impact of the magnetron on the American scientists may be judged from the secretary for war's (Henry Stimson) note in his diary after talking to Loomis -- He said we were getting the chance to start now two years ahead of where we were and we were getting infinitely more from the British than we could give them.*

At the end of September Tizard realized that financial barriers still prevented the immediate provision of major

American resources and thus he returned to Ottawa to confirm with MacKenzie the production of radar equipment in Canada. On September 25th he met with J.L. Ralston, the Minister of Defense, and other officials. Arrangements were made for Tizard to meet with C.D. Howe, the Minister of Munitions and Supply, who happened to be in Washington, to confirm the agreements arrived at in Ottawa. When Tizard met Howe in Washington on the 27th, Howe was enthusiastic about the notion of Canada producing radar equipment and the necessary vacuum tubes, and confirmed all the agreements made between Tizard and MacKenzie. Tizard left the USA to return to England on October 2nd while the other members of the mission remained in the USA.

On October 3rd Bowen and Cockcroft met in the office of Ralph Bown, the deputy director of the Bell Telephone Laboratories, with five BTL vacuum tube experts, A.L. Samuel, C.E. Fay, J.O. McNally, J.R. Pierce, and J.R. Wilson, and a representative of NRC (probably J.W. Bell) at 463 West Street in New York City. It was decided that the magnetron would be tested at the Whippany laboratory of BTL in New Jersey. On Sunday the 6th of October Bowen went to the Whippany labs and the magnetron was turned on. It immediately produced a glow discharge about an inch long at the output terminal, in spite of the fact that it had not been operated since leaving Wembley two months before; it was estimated to be producing about 15 kW peak power. F.B. Llewellyn of BTL remembered the test [18] - *It was a day to be remembered. The tube gave about 10kW peak pulse power output at a frequency in the vicinity of 3,000 MHz. This was a power about five times as great as was given by the triodes in the Mark I equipment and moreover was of a frequency over four times as high. Can you imagine our enthusiasm!*

The next day an apparent crisis arose. Bowen was phoned by Mervin Kelly, the director of BTL, in some agitation and asked to return from Washington to New York immediately. Bowen returned to West Street the next day to a chilly reception. The BTL scientists had x-rayed the magnetron and found that it had 8 cavities whereas the drawings showed only 6. The Americans were immediately suspicious of perfidious Albion. Bowen was nonplused and suggested that they telegraph Megaw at Wembley for an explanation. Megaw was reached by telephone and was at first equally puzzled, then he remembered that the first 10 magnetron were made with 6 cavities, number 11 had 7 (and did not work), and number 12 had 8 cavities. In the rush of handing over number 12 to the Tizard Mission he had forgotten to have the drawings revised. Thus was the budding international incident happily resolved.

The Bell Telephone Laboratories were contracted by the NDRC to produce thirty copies. By December 2nd 1940 BTL had delivered five magnetrons to the Radiation Laboratory at the Massachusetts Institute of Technology

which was just in the process of formation. These copies of the British tube oscillated at 9.6 cm; with an anode voltage of 10 kilovolts and a 1 microsecond pulse, peak powers of 10-15 kW were obtained. The Radiation Laboratory established its own magnetron development group which, like the BTL group, developed a wide range of microwave magnetrons. Several other manufacturers were later contracted to develop and manufacture magnetrons in the USA, including General Electric, Raytheon, RCA, and Westinghouse.

On October 20th Cockcroft and most of the other members of the Mission returned to Canada, bringing the Tizard magnetron (E1189 No.12) with them. On the 24th the members of the mission met with the Canadian War Cabinet to brief them on their meetings with the Americans. In the next few days Cockcroft, Bowen, Wallace, and R.H. Fowler (the scientific attaché to the British High Commission in Ottawa) held several meetings with officials of the National Research Council, the Department of Munitions and Supply, and the armed forces to arrange the details of the Canadian contributions to the development and production of radar and other military technologies. The Tizard Mission had already had a large impact and the Canadian government was now eager to make major commitments in support of the British proposals. The Tizard magnetron was left with the NRC, where it was once more x-rayed, so that copies could be manufactured by Northern Electric Ltd. J.T. Henderson noted - *Satisfactory magnetrons from the Northern Electric Company were received early in February 1941, and considering that no one in Canada had any knowledge of 10-centimetre magnetrons until September of 1940, this was a fine achievement.* These magnetrons were first used in the Canadian designed radar GL IIC.

One member of the mission remained behind in Canada after the others had returned to the UK. Brigadier Wallace took over as Head of the Radio Branch at NRC, which was responsible for radar research at NRC, and remained there until the end of the war. By the end of the war the number of staff members of the Radio Branch of NRC exceeded the rest of NRC combined.

THE IMPACT OF THE MICROWAVE MAGNETRON

The invention of the multicavity microwave magnetron had a dramatic effect on the development of high resolution radar in the second world war by triggering the massive research effort on microwave radar in the UK, the USA, and Canada that led to the development of many different microwave radars which were superior to any German radar. By the end of the war a great many different types of cavity magnetron had been manufactured by the allies with peak powers as high as 2 MW and wavelengths as short as 8.7 mm. Although the Germans were very well advanced in radar at the beginning of the second world war, their microwave

generators (mainly Barkhausen-Kurz oscillators) were of low power and efficiency. The Germans first discovered the multi-cavity magnetron on February 2nd, 1943, when a British Pathfinder bomber on a raid on Cologne was shot down near Rotterdam, the plane containing an H2S airborne radar using a 10 cm wavelength magnetron (type CV 76). The explosive charge, designed to destroy the radar set when the plane crashed, failed to go off. The Germans were astonished at this microwave radar and very rapidly made Chinese copies of the magnetron (even as far as copying the type number). Later in 1944 an H2X radar was captured from a crashed American bomber and the 3 cm wavelength magnetron was copied and was in production by early 1945.

The outstanding performance of the magnetron disclosed by the Tizard Mission in September 1940 persuaded the Americans of the need for a major laboratory to develop microwave radar. The result was the immediate establishment of the Radiation Laboratory at the Massachusetts Institute of Technology in Cambridge, MA., which became the major US radar laboratory. The very rapid development of magnetrons by US industry produced an astonishing number of tubes. It is estimated that, by the end of the war, well over a million magnetrons had been manufactured by at least six companies in the USA and by Northern Electric in Montreal. The Northern Electric magnetrons were labeled Research Enterprises Ltd., the government owned factory in Leaside, Ontario set up initially in July 1940 to build only optical equipment. As a result of advice from the Tizard commission, REL was greatly expanded to manufacture radar equipment. In Canada the Tizard magnetron was a major factor in persuading the government to provide resources for a program of development and production of radar equipment. This program had the effect of rapidly improving the level of technical training and skills in Canada, where there had been little prior experience in developing or manufacturing such sophisticated electronic equipment.

Microwave magnetrons now have many peaceful purposes and are used in almost all civilian radars and there is a cheap, mass-produced magnetron in nearly every kitchen in the developed world hidden in the microwave oven. These magnetrons are all descended in a direct line from E1189 number 12.

ACKNOWLEDGMENTS

Thanks are due to the late W.C. Brown for many helpful suggestions.

BIBLIOGRAPHY

P.J. Baxter, *Scientists Against Time*, Little Brown, Boston, 1946.
E.G. Bowen, *Radar Days*, Hilger, Bristol, 1987.
R. Buder, *The Invention that Changed the World*, Simon and Schuster, New York, 1996.

R. Burns editor, *Radar Development to 1945*, Peter Peregrinus, London, 1988.
E.B. Callick, *Metres to Microwaves*, Peter Peregrinus, London, 1990.
R.W. Clarke, *Sir Henry Tizard*, Methuen, London, 1965.
G.B. Collins, *Microwave Magnetrons*, McGraw-Hill, New York, 1948.
W. Eggleston, *Scientists at War*, O.U.P., London, 1950.
J.B. Fisk, H.D. Hagstrum, and P.L. Hartman, *The Magnetron as a Generator of Centimeter Waves*, Bell Syst. Tech. Jour., **25**, 167 (1946).
H. Guerlac, *Radar in World War Two*, AIP History of Modern Physics, vol. 8. American Institute of Physics, New York, 1985.
D.E.K. Middleton, *Radar Development in Canada: The Radio Branch of the National Research Council of Canada 1939-1946*. Wilfrid Laurier University Press, Waterloo, 1981.
S.W. Swords, *Technical History of the Beginning of Radar*, Institute of Electrical Engineers, History of Technology, vol. 6, 1956.
R.A. Watson Watt, *Three Steps to Victory*, Odhams, London, 1957.
D. Zimmerman, *Top Secret Exchange*, McGill-Queen's University Press, Montreal, 1996.

REFERENCES

1. J.P. Baxter, *op.cit.*, p. 142.
2. E.G. Bowen, *op.cit.*, pps. 141-149.
3. F.V. Heakes and J.T. Henderson, "Electrical Methods of Fire Control in Great Britain", N.R.C. Report PRA-6;
J.T. Henderson, "Electrical Methods of Fire Control in Great Britain (Report No. 2)", N.R.C. Report PRA-7.
4. A.W. Hull, "The Effect of a Uniform Magnetic Field on the Motion of Electrons between Coaxial Cylinders", *Phys. Rev.*, **18**, 31 (1921).
5. F.R. Elder, "The Magnetron Amplifier and Power Oscillator", *Proc. I.R.E.*, **13**, 159 (1925).
6. S.S. Swords, *op.cit.*, pps. 259-261.
7. K. Posthumus, "Oscillations in a Split Anode Magnetron", *Wireless Engineer*, **12**, 126 (1935).
8. From E.B. Collins.
9. J.H. Bryant, "The First Century of Microwaves - 1886 to 1986", *IEEE Trans. Microwave Theory and Tech.* **36**, 830 (1988).
10. A.L. Samuel, U.S. patent No. 2,063,342, issued in 1936.
11. N.T. Aleksereff and D.E. Mearoff, *Jour. Tech. Phys. USSR*, **10**, 1297 (1940). English translation in "Generation of High-Power Oscillations with a Magnetron in the Centimeter Band", *Proc. I.R.E.*, **32**, 136 (1944).
12. K. Okabe, "On the Applications of Various Electronic Phenomena and the Thermionic Tubes of New Types", *J.I.E.E. Jap. No. 463*, Suppl. Issue, p. 13 (1927).
13. H. Yagi, "Beam Transmission of Ultra-Short Waves", *Proc. I.R.E.* **16**, 715 (1928).
14. S. Nakajima, in R. Burns, *op.cit.*, p. 243.
15. R. Varian and S.F. Varian, "A High Frequency Oscillator and Amplifier", *Jour. Appl. Phys.*, **10**, 321 (1939).
16. J.T. Randall and H.A.H. Root, "Historical Notes on the Cavity Magnetron", *IEEE Trans. On Electron Devices*, **39**, 363 (1976).
17. H.A.H. Root and J.T. Randall, *Jour. I.E.E.*, **93** Part IIIa, 928 (1946).
18. E.C.S. Megaw, "The High-Power Magnetron: A Review of Early Developments", *Jour. I.E.E.*, **93**, Part IIIa, 928 (1946).
19. E.B. Callick, *op. cit.*, pps. 55 et seq.