

Power Supply

Design Guide for Desktop Platform Form Factors

Revision 1.31

April 2013



INFORMATION IN THIS DOCUMENT IS PROVIDED IN CONNECTION WITH INTEL® PRODUCTS. NO LICENSE, EXPRESS OR IMPLIED, BY ESTOPPEL OR OTHERWISE, TO ANY INTELLECTUAL PROPERTY RIGHTS IS GRANTED BY THIS DOCUMENT. EXCEPT AS PROVIDED IN INTEL'S TERMS AND CONDITIONS OF SALE FOR SUCH PRODUCTS, INTEL ASSUMES NO LIABILITY WHATSOEVER, AND INTEL DISCLAIMS ANY EXPRESS OR IMPLIED WARRANTY, RELATING TO SALE AND/OR USE OF INTEL PRODUCTS INCLUDING LIABILITY OR WARRANTIES RELATING TO FITNESS FOR A PARTICULAR PURPOSE, MERCHANTABILITY, OR INFRINGEMENT OF ANY PATENT, COPYRIGHT OR OTHER INTELLECTUAL PROPERTY RIGHT.

UNLESS OTHERWISE AGREED IN WRITING BY INTEL, THE INTEL PRODUCTS ARE NOT DESIGNED NOR INTENDED FOR ANY APPLICATION IN WHICH THE FAILURE OF THE INTEL PRODUCT COULD CREATE A SITUATION WHERE PERSONAL INJURY OR DEATH MAY OCCUR.

Intel may make changes to specifications and product descriptions at any time, without notice. Designers must not rely on the absence or characteristics of any features or instructions marked "reserved" or "undefined." Intel reserves these for future definition and shall have no responsibility whatsoever for conflicts or incompatibilities arising from future changes to them. The information here is subject to change without notice. Do not finalize a design with this information.

The products described in this document may contain design defects or errors known as errata which may cause the product to deviate from published specifications. Current characterized errata are available on request.

Contact your local Intel sales office or your distributor to obtain the latest specifications and before placing your product order.

This document contains information on products in the design phase of development.

All products, platforms, dates, and figures specified are preliminary based on current expectations, and are subject to change without notice. All dates specified are target dates, are provided for planning purposes only and are subject to change.

This document contains information on products in the design phase of development. Do not finalize a design with this information. Revised information will be published when the product is available. Verify with your local sales office that you have the latest datasheet before finalizing a design.

Intel processor numbers are not a measure of performance. Processor numbers differentiate features within each processor family, not across different processor families. See www.intel.com/products/processor_number for details.

Code names featured are used internally within Intel to identify products that are in development and not yet publicly announced for release. Customers, licensees and other third parties are not authorized by Intel to use code names in advertising, promotion or marketing of any product or services and any such use of Intel's internal code names is at the sole risk of the user.

Intel and the Intel logo are trademarks of Intel Corporation in the U.S. and other countries.

*Other names and brands may be claimed as the property of others.

Copyright © 2011-2013, Intel Corporation. All rights reserved.



Contents

Revision History.....	7
1 Introduction.....	9
1.1 Reference Documentation.....	9
1.2 Terminology.....	10
2 Processor Configurations.....	12
2.1 Processor Configurations - RECOMMENDED.....	12
3 Electrical.....	13
3.1 AC Input - REQUIRED.....	13
3.1.1 Input Over Current Protection - REQUIRED.....	13
3.1.2 Inrush Current - REQUIRED.....	13
3.1.3 Input Under Voltage - REQUIRED.....	14
3.2 DC Output - REQUIRED.....	14
3.2.1 DC Voltage Regulation.....	14
3.2.2 DC Output Current.....	14
3.2.3 Remote Sensing - RECOMMENDED.....	15
3.2.4 Other Low Power System Requirements - RECOMMENDED.....	15
3.2.5 Output Ripple Noise - REQUIRED.....	16
3.2.6 Capacitive Load - REQUIRED.....	17
3.2.7 Closed Loop Stability - REQUIRED.....	17
3.2.8 +5 VDC / +3.3 VDC Power Sequencing - REQUIRED.....	17
3.2.9 Voltage Hold-up Time - REQUIRED.....	17
3.2.10 12 V2DC Minimum Loading - REQUIRED.....	17
3.3 Timing, Housekeeping and Control - REQUIRED.....	18
3.3.1 PWR_OK.....	18
3.3.2 Power-up Cross Loading Condition.....	19
3.3.3 PS_ON#.....	19
3.3.4 +5 VSB.....	20
3.3.5 Power-on Time.....	21
3.3.6 Rise Time.....	21
3.3.7 Overshoot at Turn-on / Turn-off.....	21
3.4 Reset after Shutdown.....	21
3.4.1 +5 VSB at Power-down.....	21
3.4.2 +5 VSB Fall time Recommendation.....	21
3.5 Output Protection - REQUIRED.....	22
3.5.1 Over Voltage Protection.....	22
3.5.2 Short Circuit Protection.....	22
3.5.3 No-load Situation.....	23
3.5.4 Over Current Protection.....	23
3.5.5 Over Temperature Protection.....	23
3.5.6 Output Bypass.....	23
3.5.7 Separate Current Limit for 12V2 - RECOMMENDED.....	23
3.5.8 Overall Power Supply Efficiency and ENERGY STAR.....	23
3.5.9 Overall Power Supply Efficiency and Climate Savers.....	24
4 Mechanical.....	25
4.1 Labeling and Marking - RECOMMENDED.....	25



4.2	Connectors - REQUIRED	25
4.2.1	AC Connector	25
4.2.2	DC Connectors	25
4.3	Airflow and Fans - RECOMMENDED	29
4.3.1	Fan Location and Direction.....	29
4.3.2	Fan Size and Speed	29
4.3.3	Venting	29
5	Acoustics	30
5.1	Acoustics – RECOMMENDED	30
6	Environmental.....	31
6.1	Temperature – RECOMMENDED	31
6.2	Thermal Shock (Shipping).....	31
6.3	Humidity – RECOMMENDED.....	31
6.4	Altitude – RECOMMENDED	31
6.5	Mechanical Shock – RECOMMENDED	31
6.6	Random Vibration – RECOMMENDED	31
7	Electromagnetic Compatibility	32
7.1	Emissions – REQUIRED.....	32
7.2	Immunity - REQUIRED	32
7.3	Input Line Current Harmonic Content - OPTIONAL.....	32
7.4	Magnetic Leakage Field - REQUIRED.....	32
7.5	Voltage Fluctuations and Flicker – REQUIRED	33
8	Safety	34
8.1	North America – REQUIRED	34
8.2	International – REQUIRED.....	34
8.3	Proscribed Materials	35
8.4	Catastrophic Failure Protection - RECOMMENDED	35
9	Reliability	36
9.1	Reliability - RECOMMENDED	36
10	CFX12V Specific Guidelines 1.5.....	37
10.1	Physical Dimensions – REQUIRED	37
11	LFX12V Specific Guidelines 1.3.....	38
11.1	Physical Dimensions - REQUIRED	38
12	ATX12V Specific Guidelines 2.4	41
13	SFX12V Specific Guidelines 3.3.....	43
13.1	Lower Profile Package - Physical Dimensions - REQUIRED	43
13.2	Fan Requirements - REQUIRED.....	43
13.3	Top Fan Mount Package - Physical Dimensions -REQUIRED	45
13.4	Fan Requirements - REQUIRED.....	45
13.5	Reduced Depth Top Mount Fan - Physical.....	47
13.6	Fan Requirements - REQUIRED.....	47
13.7	Standard SFX Profile Package – Physical Dimensions - REQUIRED	48
13.8	Fan Requirements - REQUIRED.....	49
13.9	PS3 Form Factor- Physical Dimensions - REQUIRED	50
13.10	Fan Requirements - REQUIRED.....	50



14	TFX12V Specific Guidelines 2.4	52
14.1	Physical Dimensions - REQUIRED	52
14.2	Mounting Options - RECOMMENDED	54
14.3	Chassis Requirements - RECOMMENDED	55
15	Flex ATX Specific Guidelines 1.1	57
15.1	Physical Dimensions - REQUIRED	57

Figures

Figure 1	Differential Noise Test Setup	16
Figure 2	Power supply Timing	18
Figure 3	PS_ON# Signal Characteristics	20
Figure 4	5VSB Fall Time	22
Figure 5	Connectors (Pin-side view, not to Scale)	26
Figure 6	Serial ATA* Power Connector	28
Figure 7	CFX12V Mechanical Outline	37
Figure 8	Mechanical Outline	38
Figure 9	Mechanical Details	39
Figure 10	PSU Slot Feature Detail	39
Figure 11	Recommended Chassis Tab Feature	40
Figure 12	Power Supply Dimensions for Chassis that does not Require Top Venting	41
Figure 13	Power Supply Dimensions for Chassis that Require Top Venting	42
Figure 14	40 mm Profile Mechanical Outline	44
Figure 15	Chassis Cutout	44
Figure 16	Top Mount Fan Profile Mechanical Outline	46
Figure 17	Chassis Cutout	47
Figure 18	Recessed Fan Mounting	47
Figure 19	Reduced Depth Top Mount Fan Profile Mechanical Outline	48
Figure 20	Chassis Cutout	48
Figure 21	60 mm Mechanical Outline	49
Figure 22	Chassis Cutout	50
Figure 23	PS3 Mechanical Outline	51
Figure 24	Mechanical Outline	52
Figure 25	Dimensions & Recommended Feature Placements (not to scale)	53
Figure 26	Power Supply Mounting Slot Detail	54
Figure 27	Fan Right and Fan Left Orientations of Power Supply in a Chassis	55
Figure 28	Suggested TFX12V Chassis Cut out	55
Figure 29	Suggested Mounting Tab (chassis feature)	56
Figure 30	Mechanical Outline	57
Figure 31	Dimensions & Recommended Feature Placements (not to scale)	58

Table

Table 1	Conventions and terminology	10
Table 2	Support Terminology	11
Table 3	12V2 Current for Processor Configurations	12
Table 4	AC Input Line Requirements	13
Table 5	DC Output Voltage Regulation	14
Table 6	DC Output Transient Step Sizes ¹	14
Table 7	Recommended 5 VSB Efficiency	15
Table 8	DC Output Noise/Ripple	16
Table 9	Output Capacitive Loads	17
Table 10	12 V2DC Minimum Current	17
Table 11	Power Supply Timing	18



Table 12	PWR_OK Signal Characteristics	19
Table 13	PS_ON# Signal Characteristics	20
Table 14	Over Voltage Protection	22
Table 15	Efficiency versus Load	24
Table 16	Main Power Connector Pin-out	26
Table 17	Peripheral Connector Pin-out	27
Table 18	Floppy Connector Pin-out	27
Table 19	+12 V Power Connector Pin-out	28
Table 20	Serial ATA* Power Connector Pin-out	28
Table 21	Recommended Power Supply Acoustic Targets	30
Table 22	EMC Requirement by Country	32



Revision History

Revision	Description	Date
0.5	<ul style="list-style-type: none"> ● Initial release of combined power supply design guide ● Combined CFX12V, LFX12V, ATX12V, SFX12V, and TFX12V content into one desktop power supply design guide ● CFX12V content derived from revision 1.2 <ul style="list-style-type: none"> ■ Updated 12V1 current for 300 W configuration ■ Updated efficiency loading for 300 W configuration ● LFX12V content derived from revision 1.1 ● ATX12V content derived from revision 2.2 ● SFX12V content derived from revision 3.1 ● TFX12V content derived from revision 2.1 <ul style="list-style-type: none"> ■ Updated 12V1 current for 300 W configuration ■ Updated efficiency loading for 300 W configuration ● Updated Capacitive Load section to use standard capacitor values ● Updated 5 VSB efficiency recommendations for Digital Office platforms ● Removed power-down warning from power supply timing diagram ● Marked sections with labels to indicate REQUIRED, RECOMMENDED, or OPTIONAL items 	January 2006
1.0	<ul style="list-style-type: none"> ● Added 12V2 Current for Processor Configurations table ● Added revision numbers to form factor specific chapters ● Changed Input Line Current Harmonic Content to OPTIONAL to better reflect geographical requirements 	June 2006
1.1	<ul style="list-style-type: none"> ● Removed outdated ENERGY STAR* requirements and added some new ENERGY STAR information. ● Updated Typical Power Distribution tables for all power supply form factors and updated minimum loads. ● Updated cross regulation figures. ● Added Flex ATX power supply form factor. ● Updated capacitive loading table. ● Clarified over voltage and over current verbiage. ● Added Power-up Cross Loading Condition section. ● Other changes shown in red with change bars. 	March 2007
1.2	<ul style="list-style-type: none"> ● 3.3.1 and Added max of 400 mV Ripple/Noise to PS_ON and PWR_OK signals ● 14.2 Figure 49 replaced to implement change in dimension C ● 3.3 Added Power-down timing to Figure 2 and Table 20 (T6 > 1 ms) ● 7.3 Clarified Class D requirements. Added additional references for EMC requirements by country ● 3.5.9 Added Climate Savers Computing text ● Updated all Cross-regulation graphs ● 2.0 updated configuration charts ● Removed dates from reference documentation. Refer to latest version available ● Updated figure 58 	February 2008



1.3	<ul style="list-style-type: none">● Updated 3.2.3 Remote sensing to recommended level● Added 3.2.10 12 V2DC Minimum Loading Recommendation● Added 3.4.2 +5 VSB Fall time Recommendation● Updated 3.2.9 Voltage Hold-up Time● Updated 3.5.8 Overall Power Supply Efficiency and ENERGY STAR● Changed 4.2.2.3 Floppy Drive Connector to OPTIONAL level● Changed 4.2.2.5 Serial ATA Connectors to Required level● Update Table 3 12V2 Current for Processor Configurations● Updated Table 5 DC Output Voltage Regulation -12V to recommended level● Updated Table 7 Recommended System DC and AC power consumption● Updated Table 11 Power Supply Timing recommended value● Updated Table 15 Efficiency versus Load	July 2012
1.31	<ul style="list-style-type: none">● Updated Table 7 Recommended System DC and AC power consumption● Changed 3.2.10 12 V2DC Minimum Loading to REQUIRED● Updated 3.3.6 Rise Time● Updated<ul style="list-style-type: none">CFX12V Specific Guidelines to version 1.5LFX12V Specific Guidelines to version 1.3ATX12V Specific Guidelines to version 2.4SFX12V Specific Guidelines to version 3.3TFX12V Specific Guidelines to version 2.4Flex ATX Specific Guidelines to version 1.1	April 2013



1 Introduction

This document provides design suggestions for various power supply form factors. The power supplies are primarily intended for use with desktop system designs. It should not be inferred that all power supplies must conform exactly to the content of this document, though there are key parameters that define mechanical fit across a common set of platforms. Since power supply needs vary depending on system configuration, the design specifics described are not intended to support all possible systems.

1.1 Reference Documentation

The following documents are referenced in various sections of this design guide. For guidelines not specifically mentioned here, please reference the appropriate document.

Document	Document Number /Source or Password
European Association of Consumer Electronics Manufacturers (EACEM*) Hazardous Substance List / Certification	AB13-94-146
IEEE* Recommended Practice on Surge Voltages in Low-Voltage AC Circuits	ANSI* C62.41-1991
IEEE Guide on Surge Testing for Equipment Connected to Low-Voltage AC Power Circuits	ANSI C62.45-1992
Nordic national requirement in addition to EN 60950	EMKO-TSE (74-SEC) 207/94
American National Standard for Methods of Measurement of Radio-Noise Emissions from Low-Voltage Electrical and Electronic Equipment in the Range of 9 kHz to 40 GHz for EMI testing	ANSI C63.4



Document	Document Number /Source or Password
UL 60950-1 First Edition –CAN/CSA-C22.2 No. 60950-1-03 First Edition, IEC 60950-1: 2001 + Amendments and National Deviations, EN 60950-1: 2001 + Amendment A11: EU Low Voltage Directive (73/23/EEC) (CE Compliance) GB-4943 (China) CNS 14336: (Taiwan BSMI) FCC*, Class B, Part 15 (Radiated & Conducted Emissions) CISPR* 22 / EN55022, 5th Edition (Radiated & Conducted Emissions) EN55024 (ITE Specific Immunity) EN 61000-4-2 – Electrostatic Discharge EN 61000-4-3– Radiated RFI Immunity EN 61000-4-4– Electrical Fast Transients EN 61000-4-5 – Electrical Surge EN 61000-4-6 – RF Conducted EN 61000-4-8 – Power Frequency Magnetic Fields EN 61000-4-11 – Voltage Dips, Short Interrupts and Fluctuations EN61000-3-2 (Harmonics) EN61000-3-3 (Voltage Flicker) EU EMC Directive ((8/9/336/EEC) (CE Compliance)	

1.2 Terminology

Table 1 defines the acronyms, conventions, and terminology that are used throughout the design guide.

Table 1 Conventions and terminology

Acronym, Convention/ Terminology	Description
AWG	American Wire Gauge
BA	Declared sound power, LwAd. The declared sound power level shall be measured according to ISO* 7779 for the power supply and reported according to ISO 9296.
CFM	Cubic Feet per Minute (airflow).
Monotonically	A waveform changes from one level to another in a steady fashion, without oscillation.
MTBF	Mean time between failure.
Noise	The periodic or random signals over frequency band of 0 Hz to 20 MHz.
Optional	The status given to items within this design guide, which are



Acronym, Convention/ Terminology	Description
	not required to meet design guide, however, some system applications may optionally use these features.
Overcurrent	A condition in which a supply attempts to provide more output current than the amount for which it is rated. This commonly occurs if there is a "short circuit" condition in the load attached to the supply.
PFC	Power Factor Correction.
PWR_OK	PWR_OK is a "power good" signal used by the system power supply to indicate that the +5VDC, +3.3 VDC and +12VDC outputs are above the under voltage thresholds of the power supply.
Ripple noise	The periodic or random signals over a frequency band of 0 Hz to 20 MHz.
Rise Time	Rise time is defined as the time it takes any output voltage to rise from 10% to 90% of its nominal voltage.
Surge	The condition where the AC line voltage rises above nominal voltage.
VSB or Standby Voltage	An output voltage that is present whenever AC power is applied to the AC inputs of the supply.

Table 2 Support Terminology

Category	Description
Optional	The status given to items within this design guide, which are not required to meet design guide, however, some system applications may optionally use these features. May be a required or recommended item in a future design guide.
Recommended	The status given to items within this design guide, which are not required to meet design guide, however, are required by many system applications. May be a required item in a future design guide.
Required	The status given to items within this design guide, which are required to meet design guide and a large majority of system applications.



2 Processor Configurations

2.1 Processor Configurations - RECOMMENDED

Table 3 shows various processor configurations for 12V2 current recommendation.

Table 3 12V2 Current for Processor Configurations

PSU 12V2 Capability Recommendations		
Processor TDP	Continuous Current	Peak Current
95W	16A	18A
65W	11A	14A
45W	7.6A	12A
35W	6A	10A

NOTES:

PSU rail voltage is 11.4V, 12V2 should be able to supply peak current for 10 ms.

PL2=PL1*1.25

Motherboard VR efficiency is 85% at TDC and 80% at IccMax

Motherboard plane resistance is 1.2mOhm



3 Electrical

The following electrical requirements are required and must be met over the environmental ranges as defined in Chapter 6 (unless otherwise noted).

3.1 AC Input - REQUIRED

Table 4 lists AC input voltage and frequency requirements for continuous operation. The power supply shall be capable of supplying full-rated output power over two input voltage ranges rated 100-127 VAC and 200-240 VAC rms nominal. The correct input range for use in a given environment may be either switch-selectable or auto-ranging. The power supply shall automatically recover from AC power loss. The power supply must be able to start up under peak loading at 90 VAC.

Note: OPTIONAL - 115 VAC or 230 VAC only power supplies are an option for specific geographical or other requirements.

Table 4 AC Input Line Requirements

Parameter	Minimum	Nominal ¹	Maximum	Unit
V _{in} (115 VAC)	90	115	135	VAC _{rms}
V _{in} (230VAC)	180	230	265	VAC _{rms}
V _{in} Frequency	47	-	63	Hz
I _{in} (115 VAC)	-	-	6	A _{rms}
I _{in} (230VAC)	-	-	3	A _{rms}

NOTES:

1. Nominal voltages for test purposes are considered to be within ± 1.0 V of nominal.

3.1.1 Input Over Current Protection – REQUIRED

The power supply is required to incorporate primary fusing for input over current protection to prevent damage to the power supply and meet product safety requirements. Fuses should be slow-blow-type or equivalent to prevent nuisance trips.

3.1.2 Inrush Current – REQUIRED

Maximum inrush current from power-on (with power-on at any point on the AC sine) and including, but not limited to, three line cycles, shall be limited to a level below the surge rating of the AC switch if present, bridge rectifier, and fuse components. Repetitive ON/OFF cycling of the AC input voltage should not damage the power supply or cause the input fuse to blow.



3.1.3 Input Under Voltage – REQUIRED

The power supply is required to contain protection circuitry such that the application of an input voltage below the minimum specified in Table 4, shall not cause damage to the power supply.

3.2 DC Output - REQUIRED

3.2.1 DC Voltage Regulation

The DC output voltages are required to remain within the regulation ranges shown in Table 5, when measured at the load end of the output connectors under all line, load, and environmental conditions specified in Chapter 6.

Table 5 DC Output Voltage Regulation

Output	Range	Min	Nom	Max	Unit
+12V1DC ¹	±5%	+11.40	+12.00	+12.60	V
+12V2DC ²	±5%	+11.40	+12.00	+12.60	V
+5VDC	±5%	+4.75	+5.00	+5.25	V
+3.3VDC ³	±5%	+3.14	+3.30	+3.47	V
-12VDC ⁴	±10%	-10.80	-12.00	-13.20	V
+5VSB	±5%	+4.75	+5.00	+5.25	V

NOTES:

1. At +12V1DC peak loading, regulation at the +12V1DC and +12V2DC outputs can go to ±5%.
2. At +12V2DC peak loading, regulation at the +12V1DC and +12V2DC outputs can go to ±5%
3. Voltage tolerance is required at main connector and SATA connector (if used)
4. -12VDC output is optional

3.2.2 DC Output Current

Table 6 summarizes the expected output transient step sizes for each output. The transient load slew rate is = 1.0 A/μs.

Table 6 DC Output Transient Step Sizes¹

Output	Maximum Step Size (% of rated output amps)	Maximum Step Size (A)
+12V1DC	40%	-
+12V2DC	60%	-
+5VDC	30%	-
+3.3VDC	30%	-



Output	Maximum Step Size (% of rated output amps)	Maximum Step Size (A)
-12VDC	-	0.1
+5VSB	-	0.5

NOTES:

1. For example, for a rated +5 VDC output of 14A, the transient step would be $30\% \times 14 \text{ A} = 4.2 \text{ A}$.

Output voltages should remain within the regulation limits of Table 5, for instantaneous changes in load as specified in Table 6 and for the following conditions:

- Simultaneous load steps on the +12 VDC, +5 VDC, and +3.3 VDC outputs (all steps occurring in the same direction)
- Load-changing repetition rate of 50 Hz to 10 kHz
- AC input range per Section 2.1 and Capacitive loading per Table 9

3.2.3 Remote Sensing - RECOMMENDED

Remote sensing is defined as recommended level and can accurate control at motherboard loads by adding to PSU connector. The +3.3 VDC output should have provisions for remote sensing to compensate for excessive cable drops. In low power PSU, remote sensing is recommended. The default sense should be connected to pin 13 of the main power connector (Figure 5). The power supply should draw no more than 10 mA through the remote sense line to keep DC offset voltages to a minimum.

3.2.4 Other Low Power System Requirements - RECOMMENDED

To help meet the Blue Angel* system requirements, RAL-UZ 78, US Presidential executive order 13221, ENERGY STAR*, ErP Lot6 requirements, and other low Power system demands, it is recommended that the +5 VSB standby supply power consumption should be as low as possible. In order to meet the 2010 and 2013 ErP Lot 6 requirements and 2014 and 2016 ErP Lot 26 requirements, 5V standby efficiency should be met as shown in Table 7 which is measured with the main outputs off (PS_ON# high state).

Table 7 Recommended System DC and AC power consumption

5VSB Power Consumption	System AC wall Power Consumption
≤0.225W	< 0.5W to meet 2013 ErP Lot 6* requirement (100V~240V)
≤0.45W	< 1W to meet ErP Lot 6* requirement (100V~240V)
≤2.75W	< 5W to meet 2014 ErP Lot 3* requirement (100V~240V)

NOTES : * Other names and brands may be claimed as the property of others-page 2

3.2.5 Output Ripple Noise - REQUIRED

The output ripple noise requirements listed in Table 8 should be met throughout the load ranges specified for the appropriate form factor and under all input voltage conditions as specified in Table 4

Ripple and noise are defined as periodic or random signals over a frequency band of 10 Hz to 20 MHz. Measurements shall be made with an oscilloscope with 20 MHz of bandwidth. Outputs should be bypassed at the connector with a 0.1µF ceramic disk capacitor and a 10 µF electrolytic capacitor to simulate system loading. See Figure 1 for the differential noise measurement setup.

Table 8 DC Output Noise/Ripple

Output	Maximum Ripple and Noise (mV p-p)
+12V1DC	120
+12V2DC	120
+5VDC	50
+3.3VDC	50
-12VDC	120
+5VSB	50

Figure 1 Differential Noise Test Setup

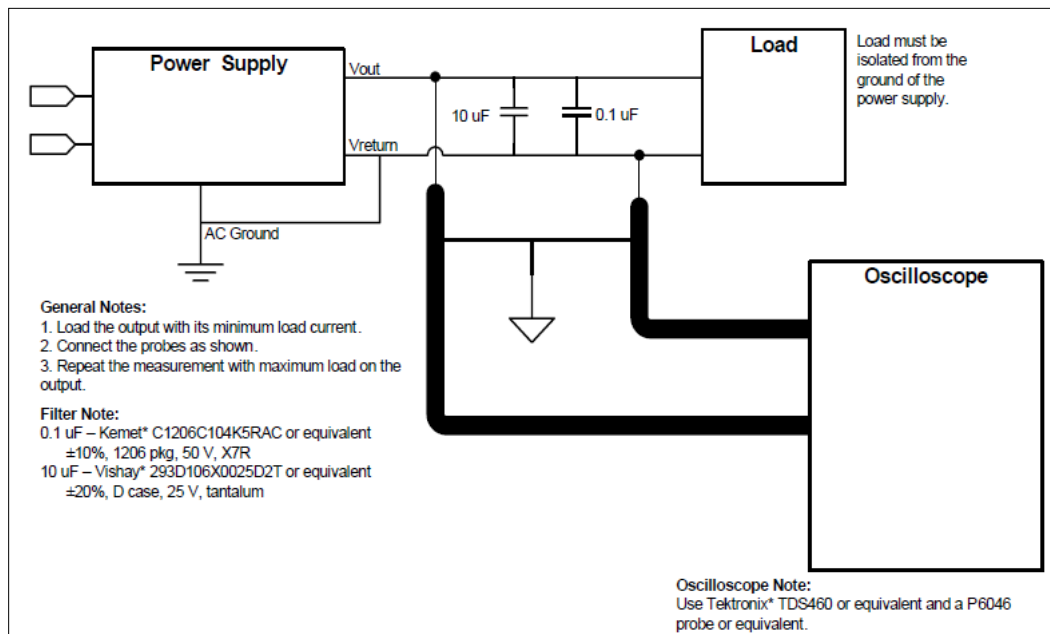



3.2.6 Capacitive Load - REQUIRED

The power supply should be able to power up and operate with the regulation limits defined in Table 5, with the following capacitances simultaneously present on the DC outputs.

Table 9 Output Capacitive Loads

Output	Capacitive Load (μF)
+12V1DC	10,000
+12V2DC	10,000
+5VDC	10,000
+3.3VDC	10,000
-12VDC	330
+5VSB	10,000

3.2.7 Closed Loop Stability - REQUIRED

The power supply shall be unconditionally stable under all line/load/transient load conditions including capacitive loads specified in Section 3.2.6. A minimum of 45 degrees phase margin and 10 dB gain margin is recommended at both the maximum and minimum loads.

3.2.8 +5 VDC / +3.3 VDC Power Sequencing - REQUIRED

The +12V1 DC / +12V2 DC and +5 VDC output levels must be equal to or greater than the +3.3 VDC output at all times during power-up and normal operation. The time between any output of +12V1 DC / +12V2 DC and +5 VDC reaching its minimum in-regulation level and +3.3 VDC reaching its minimum in-regulation level must be \leq 20 ms.

3.2.9 Voltage Hold-up Time - REQUIRED

The power supply should maintain output regulations per Table 5 despite a loss of input power at the low-end nominal range-115 VAC / 47 Hz or 230 VAC / 47 Hz – at maximum continuous output load as applicable for a minimum of 17 ms.

3.2.10 12 V2DC Minimum Loading - REQUIRED

The power supply +12 V2DC should maintain output regulations per Table 5 and meet minimum current recommendation as below.

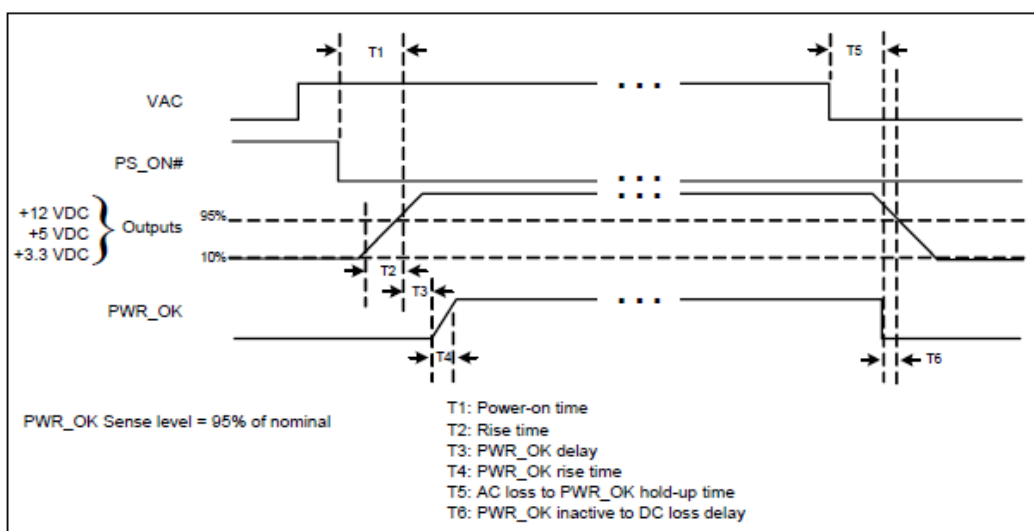

Table 10 12 V2DC Minimum Current

Output	Minimum current (A)	Recommended Minimum current (A)
+12 V2DC	0.05	0

3.3 Timing, Housekeeping and Control – REQUIRED

Figure 2 Power supply Timing



3.3.1 PWR_OK

PWR_OK is a “power good” signal. This signal should be asserted high by the power supply to indicate that the +12 VDC, +5 VDC, and +3.3 VDC outputs are within the regulation thresholds listed in Table 5 and that sufficient mains energy is stored by the converter to guarantee continuous power operation within specification for at least the duration specified in Section 3.2.9. Conversely, PWR_OK should be de-asserted to a low state when any of the +12 VDC, +5 VDC, or +3.3 VDC output voltages falls below its under voltage threshold, or when mains power has been removed for a time sufficiently long such that power supply operation cannot be guaranteed. The electrical and timing characteristics of the PWR_OK signal are given in Table 12 and in Figure 2.

Table 11 Power Supply Timing

Parameter	Description	Value	
		Required	Recommended
T1	Power-on time	< 500ms	< 200ms



Parameter	Description	Value	
T2	Rise time	0.2 – 20 ms	-
T3	PWR_OK delay	100 – 500 ms	100 – 250 ms
T4	PWR_OK rise time	< 10 ms	-
T5	AC loss to PWR_OK hold-up time	> 16 ms	-
T6	PWR_OK inactive to DC loss delay	> 1 ms	-

Table 12 PWR_OK Signal Characteristics

Signal Type	+5 V TTL compatible
Logic level low	< 0.4 V while sinking 4 mA
Logic level high	Between 2.4 V and 5 V output while sourcing 200 μ A
High state output impedance	1 k Ω from output to common
Max Ripple/Noise	400 mV pk-pk

3.3.2 Power-up Cross Loading Condition

In the time frame between PS_ON# assertion and PWR_OK assertion (T1+T3), the power supply may be subjected to a cross load condition on the 12 V and 3.3/5 V rails. The power supply should be able to successfully power-up and assert PWR_OK when 12 V (or combination of 12V1 and 12V2) is loaded to \leq 0.1 A and 3.3 V and/or 5 V are loaded to 0-5 A.

3.3.3 PS_ON#

PS_ON# is an active-low, TTL-compatible signal that allows a motherboard to remotely control the power supply in conjunction with features such as soft on/off, Wake on LAN*, or wake-on-modem. When PS_ON# is pulled to TTL low, the power supply should turn on the four main DC output rails: +12 VDC, +5 VDC, +3.3 VDC, and -12 VDC. When PS_ON# is pulled to TTL high or open-circuited, the DC output rails should not deliver current and should be held at zero potential with respect to ground. PS_ON# has no effect on the +5 VSB output, which is always enabled whenever the AC power is present. Table 13 lists PS_ON# signal characteristics.

The power supply shall provide an internal pull-up to TTL high. The power supply shall also provide de-bounce circuitry on PS_ON# to prevent it from oscillating on/off at startup when activated by a mechanical switch. The DC output enable circuitry must be SELV-compliant.

The power supply shall not latch into a shutdown state when PS_ON# is driven active by pulses between 10 ms to 100 ms during the decay of the power rails.



Table 13 PS_ON# Signal Characteristics

Parameter	Minimum	Maximum
V_{IL}	0	0.8 V
I_{IL} ($V_{IN} = 0.4$ V)	-	-1.6 mA ¹
V_{IH} ($I_{IN} = -200$ μ A)	2.0 V	-
V_{IH} open circuit	-	- 5.25 V
Ripple / Noise		400 mV pk-pk

NOTES:

1. Negative current indicates that the current is flowing from the power supply to the motherboard.

Figure 3 PS_ON# Signal Characteristics

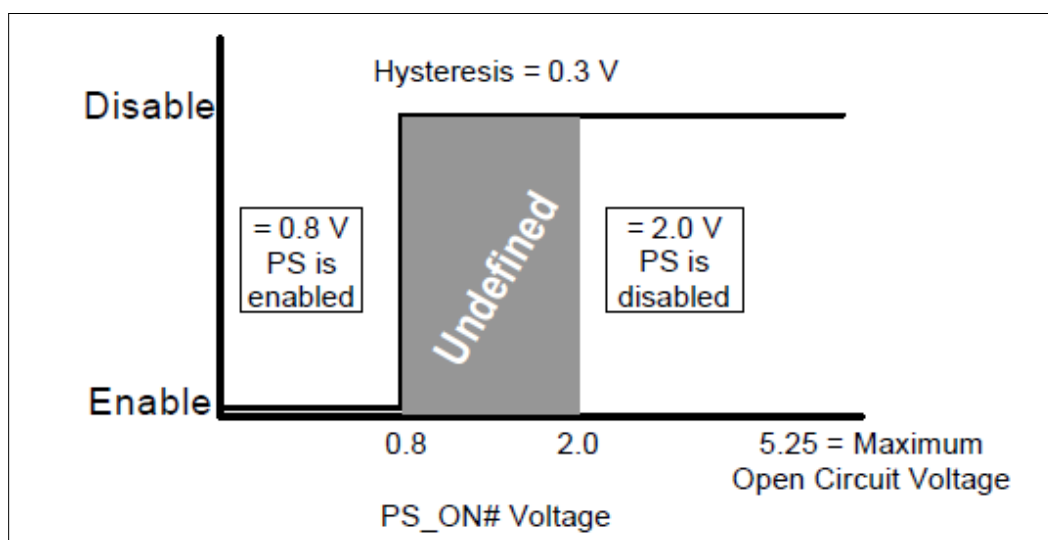

3.3.4 +5 VSB

+5 VSB is a standby supply output that is active whenever the AC power is present. This output provides a power source for circuits that must remain operational when the five main DC output rails are in a disabled state. Example uses include soft power control, Wake on LAN, wake-on-modem, intrusion detection, or suspend state activities.

The power supply must be able to provide the required power during a “wake up” event. If an external USB device generates the event, there may be peak currents as high as 2.5 A., lasting no more than 500ms.

Over current protection is required on the +5 VSB output regardless of the output current rating. This ensures the power supply will not be damaged if external circuits draw more current than the supply can provide.



3.3.5 Power-on Time

The power-on time is defined as the time from when PS_ON# is pulled low to when the +12 VDC, +5 VDC, and +3.3 VDC outputs are within the regulation ranges specified in Table 5. The power-on time shall be less than 500 ms ($T1 < 500$ ms).

+5 VSB shall have a power-on time of two second maximum after application of valid AC voltages.

3.3.6 Rise Time

The output voltages shall rise from 10% of nominal to within the regulation ranges specified in Table 5 within 0.2 ms to 20 ms ($0.2 \text{ ms} \leq T2 \leq 20 \text{ ms}$).

There must be a smooth and continuous ramp of each DC output voltage from 10% to 95% of its final set point within the regulation band, while loaded as specified.

The smooth turn-on requires that, during the 10% to 95% portion of the rise time, the slope of the turn-on waveform must be positive and have a value of between 0 V/ms and $[V_{out, \text{nominal}} / 0.2]$ V/ms. Also, for any 5 ms segment of the 10% to 95% rise time waveform, a straight line drawn between the end points of the waveform segment must have a slope $\geq [V_{out, \text{nominal}} / 20]$ V/ms.

3.3.7 Overshoot at Turn-on / Turn-off

The output voltage overshoot upon the application or removal of the input voltage, or the assertion/de-assertion of PS_ON#, under the conditions specified in Table 5, shall be less than 10% above the nominal voltage. No voltage of opposite polarity shall be present on any output during turn-on or turn-off.

3.4 Reset after Shutdown

If the power supply latches into a shutdown state because of a fault condition on its outputs, the power supply shall return to normal operation only after the fault has been removed and the PS_ON# has been cycled OFF/ON with a minimum OFF time of one second.

3.4.1 +5 VSB at Power-down

After AC power is removed, the +5 VSB standby voltage output should remain at its steady state value for the minimum hold-up time specified in Section 3.2.9 until the output begins to decrease in voltage. The decrease shall be monotonic in nature, dropping to 0.0 V. There shall be no other disturbances of this voltage at or following removal of AC power.

3.4.2 +5 VSB Fall time Recommendation

Power supply 5VSB is recommended to go down to low level within 2 seconds after AC power is removed as shown in Figure 4.



Figure 4 5VSB Fall Time

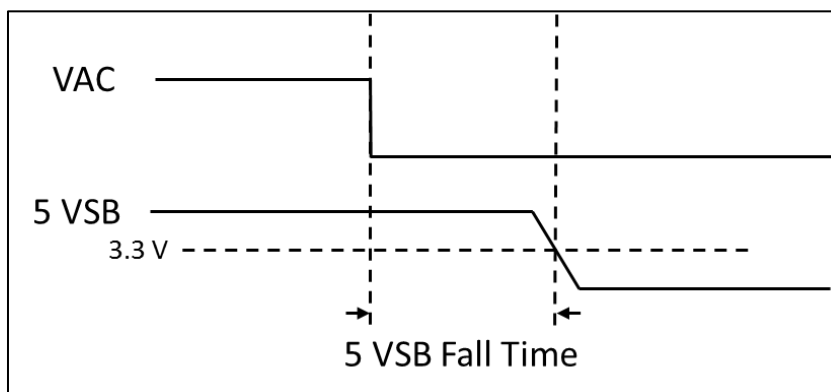

3.5 Output Protection - REQUIRED

3.5.1 Over Voltage Protection

The over voltage sense circuitry and reference shall reside in packages that are separate and distinct from the regulator control circuitry and reference. No single point fault shall be able to cause a sustained over voltage condition on any or all outputs. The supply shall provide latch-mode over voltage protection as defined in Table 14.

Table 14 Over Voltage Protection

Output	Minimum (V)	Nominal (V)	Maximum (V)
+12 VDC (or 12V1DC & 12V2DC)	13.4	15.0	15.6
+5VDC	5.74	6.3	7.0
+3.3VDC	3.76	4.2	4.3
+5VSB ¹	5.74	6.3	7.0

NOTES:

- Over voltage protection is RECOMMENDED but not REQUIRED for this output. While over voltage protection is not required for this output, system damage may occur in the case of an over voltage event.

3.5.2 Short Circuit Protection

An output short circuit is defined as any output impedance of less than 0.1 ohms. The power supply shall shut down and latch off for shorting the +3.3 VDC, +5 VDC, or +12 VDC rails to return or any other rail. The +12V1 DC and 12V2 DC should have separate short circuit and over current protection. Shorts between main output rails and +5 VSB shall not cause any damage to the power supply. The power supply shall either shut down and latch off or fold back for shorting the negative rails. +5 VSB must be capable of being shorted indefinitely. When the short is removed, it is



recommended that the power supply shall recover automatically or by cycling PS_ON#. Optionally, the power supply may latch off when a +5 VSB short circuit event occurs. The power supply shall be capable of withstanding a continuous short circuit to the output without damage or overstress to the unit (for example, to components, PCB traces, and connectors) under the input conditions specified in Table 4.

3.5.3 No-load Situation

No damage or hazardous condition should occur with all the DC output connectors disconnected from the load. The power supply may latch into the shutdown state.

3.5.4 Over Current Protection

Current protection should be designed to limit the current to operate within safe operating conditions.

Over current protection schemes where only the voltage output that experiences the over current event is shut off may be adequate to maintain safe operation of the power supply and the system; however, damage to the motherboard or other system components may occur. The recommended over current protection scheme is for the power supply to latch into the shutdown state.

3.5.5 Over Temperature Protection

As an option, the power supply may include an over-temperature protection sensor, which can trip and shut down the power supply at a preset temperature point. Such an overheated condition is typically the result of internal current overloading or a cooling fan failure. If the protection circuit is non-latching, then it should have hysteresis built in to avoid intermittent tripping.

3.5.6 Output Bypass

The output return may be connected to the power supply chassis, and will be connected to the system chassis by the system components.

3.5.7 Separate Current Limit for 12V2 - RECOMMENDED

The 12 V rail on the 2x2 power connector should be a separate current limited output to meet the requirements of UL and EN 60950.

3.5.8 Overall Power Supply Efficiency and ENERGY STAR

The efficiency of the power supply should be tested at nominal input voltage of 115 VAC input and 230 VAC input, under the load conditions defined in the form factor specific sections, and under the temperature and operating conditions defined in Chapter 6. The loading condition for testing efficiency shown in the form factor specific guidelines sections represent fully loaded systems, typical (50%) loaded systems, and light (20%) loaded systems.



Table 15 Efficiency versus Load

Loading	Full Load (100%)	Typical Load (50%)	Light Load (20%)	PFC
REQUIRED Minimum Efficiency	70%	72%	65%	-
RECOMMENDED Minimum Efficiency	82%	85%	82%	≥0.9

The RECOMMENDED minimum efficiency levels shown in Table 15 are required for ENERGY STAR system compliance based the version 5.2 specification.

The ENERGY STAR computer specification requires at least 82% efficiency at 20%, 50% and 100% of the rated output capacity. This effectively provides a window of high efficiency that extends from 20% to 100% of the rated capacity of the power supply. Generally the efficiency of the power supply drops off significantly as the load falls below 20%. Because the power supply is one of the largest contributors to power loss in the system, it is important to maximize the efficiency in order to comply with the power targets for the various system categories.

3.5.9 Overall Power Supply Efficiency and Climate Savers

The Climate Savers Computing Initiative operates in a manner similar to the U.S. Government's Energy Star program. It is intended to promote both the deployment of existing technologies and investment in new energy-efficiency technologies. The new Energy Star standard for desktops, laptops, and workstations, which takes effect in July 2007, requires power supplies to be at least 80% efficient for most of their load range. In addition, it puts limits on the energy used by devices when inactive and requires systems to be shipped with power management features enabled. The Challenge starts with the 2007 Energy Star requirements for desktops, laptops, and workstations (including monitors), and gradually increases the efficiency requirements over the next 4 years, as follows:

1. From July 2007 through June 2008, PCs must meet the Energy Star requirements. This means 80% minimum efficiency for the power supply unit (PSU) at 20%, 50%, and 100% of rated output, a power factor of at least 0.9 at 100% of rated output, and meeting the maximum power requirements in standby, sleep, and idle modes.
2. From July 2008 through June 2009 the standard increases to 85% minimum efficiency for the PSU at 50% of rated output (and 82% minimum efficiency at 20% and 100% of rated output).
3. From July 2009 through June 2010, the standard increases to 88% minimum efficiency for the PSU at 50% of rated output (and 85% minimum efficiency at 20% and 100% of rated output).
4. From July 2010 through June 2011, the standard increases to 90% minimum efficiency for the PSU at 50% of rated output (and 87% minimum efficiency at 20% and 100% of rated output). For more information on the Climate Savers Computing Initiative, visit their website at www.climatesaverscomputing.org.



4 *Mechanical*

This section contains mechanical guidelines that apply to desktop power supplies regardless of form factor. For form factor specific design guides refer to Chapter 10 through Chapter 14.

4.1 **Labeling and Marking - RECOMMENDED**

The following is a non-inclusive list of suggested markings for each power supply unit. Product regulation stipulations for sale into various geographies may impose additional labeling requirements.

Manufacturer information: manufacturer's name, part number and lot date code, etc., in human-readable text and/or bar code formats

Nominal AC input operating voltages (100-127 VAC and 200-240 VAC) and current rating certified by all applicable safety agencies

DC output voltages and current ratings

Access warning text ("Do not remove this cover. Trained service personnel only. No user serviceable components inside.") must be in English, German, Spanish, French, Chinese, and Japanese with universal warning markings.

4.2 **Connectors - REQUIRED**

4.2.1 **AC Connector**

The AC input receptacle should be an IEC 320 type or equivalent. In lieu of a dedicated switch, the IEC 320 receptacle may be considered the mains disconnect.

4.2.2 **DC Connectors**

Table 8 shows pin outs and profiles for typical power supply DC harness connectors. The power supply requires an additional two-pin, power connector.

UL Listed or recognized component appliance wiring material rated min 85 °C, 300 VDC shall be used for all output wiring.

There are no specific requirements for output wire harness lengths, as these are largely a function of the intended end-use chassis, motherboard, and peripherals. Ideally, wires should be short to minimize electrical/airflow impedance and simplify manufacturing, yet they should be long enough to make all necessary connections without any wire tension (which can cause disconnections during shipping and handling). Recommended minimum harness lengths for general-use power supplies is 150 mm for all wire harnesses. Measurements are made from the exit port of the power supply case to the wire side of the first connector on the harness.

Figure 5 Connectors (Pin-side view, not to Scale)

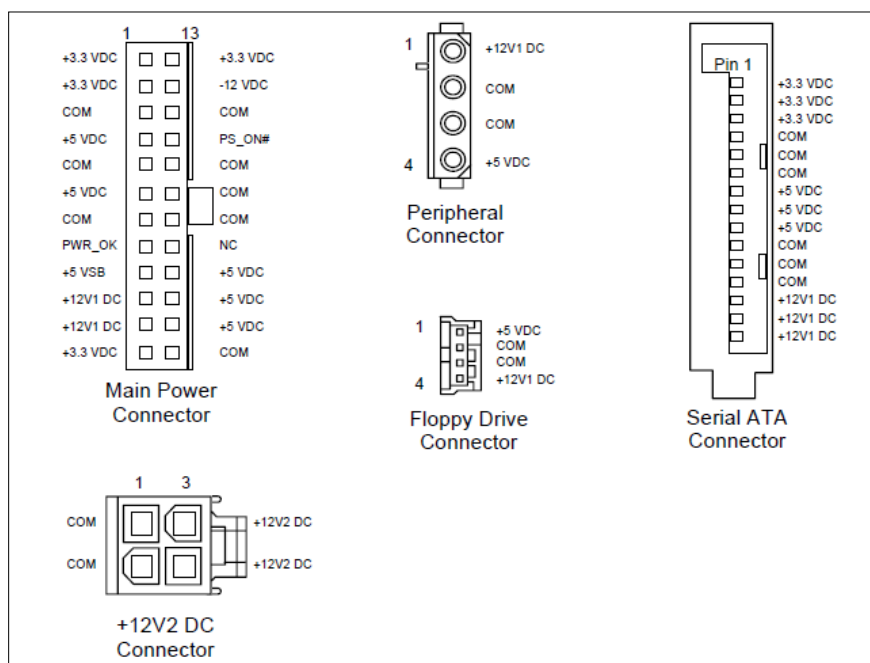

NOTES:

1. Floppy Drive Connector is optional

4.2.2.1 Main Power Connector

Connector: Molex* Housing: 24 Pin Molex Mini-Fit Jr. PN# 39-01-2240 or equivalent.

Contact: Molex 44476-1112 (HCS) or equivalent (Mating motherboard connector is Molex 44206-0007 or equivalent).

18 AWG is suggested for all wires except for the +3.3 V supply and sense return wires combined into pin 13 (22 AWG).

Table 16 Main Power Connector Pin-out

Pin	Signal	Color	Pin	Signal	Color
1	+3.3 VDC	Orange	13	+3.3 VDC [+3.3 V default sense]	Orange [Brown]
2	+3.3 VDC	Orange	14	-12 VDC	Blue
3	COM	Black	15	COM	Black
4	+5 VDC	Red	16	PS_ON#	Green
5	COM	Black	17	COM	Black
6	+5 VDC	Red	18	COM	Black
7	COM	Black	19	COM	Black



Pin	Signal	Color	Pin	Signal	Color
8	PWR_OK	Gray	20	Reserved	NC
9	+5 VSB	Purple	21	+5 VDC	Red
10	+12 V1DC	Yellow	22	+5 VDC	Red
11	+12 V1DC	Yellow	23	+5 VDC	Red
12	+3.3 VDC	Orange	24	COM	Black

4.2.2.2 Peripheral Connectors

Connector: AMP* 1-480424-0 or Molex* 15-24-4048 or equivalent.

Contacts: AMP 61314-1 or equivalent.

Table 17 Peripheral Connector Pin-out

Pin	Signal	Color ¹
1	+12 V1DC	Yellow
2	COM	Black
3	COM	Black
4	+5 VDC	Red

NOTES:

1. 18 AWG wire.

4.2.2.3 Floppy Drive Connector - OPTIONAL

Connector: AMP* 171822-4 or equivalent.

Table 18 Floppy Connector Pin-out

Pin	Signal	Color ¹
1	+5 VDC	Red
2	COM	Black
3	COM	Black
4	+12 V1DC	Yellow

NOTES:

1. 20 AWG wire.

4.2.2.4 +12 V Power Connector

Connector: Molex* 0039012040 or equivalent.

Contact: Molex 44476-1112 (HCS) or equivalent (Mating motherboard connector is Molex 39-29-9042 or equivalent).

Table 19 +12 V Power Connector Pin-out

Pin	Signal	Color ¹	Pin	Signal	Color ¹
1	COM	Black	3	+12 V2DC	Yellow
2	COM	Black	4	+12 V2DC	Yellow

NOTES:

1. 18 AWG wire.

4.2.2.5 Serial ATA* Connectors – Required

This is a required connector for systems with Serial ATA devices.

The detailed requirements for the Serial ATA Power Connector can be found in the “Serial ATA: High Speed Serialized AT Attachment” specification, Section 6.3 “Cables and connector specification”.
<http://www.serialata.org/>

Note: Connector pin numbers and wire numbers are not 1:1. Carefully check to confirm the correct arrangement.

Assembly: Molex* 88751 or equivalent..

Table 20 Serial ATA* Power Connector Pin-out

Wire	Signal	Color ¹
5	+3.3 VDC	Orange
4	COM	Black
3	+5 VDC	Red
2	COM	Black
1	+12 V1DC	Yellow

NOTES:

1. 18 AWG wire.

Figure 6 Serial ATA* Power Connector

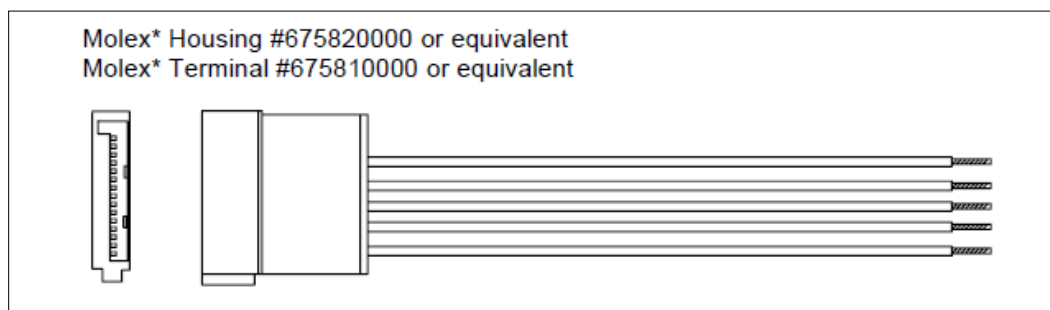



4.3 Airflow and Fans - RECOMMENDED

The designer's choice of a power supply cooling solution depends in part on the targeted end-use system application(s). At a minimum, the power supply design must ensure its own reliable and safe operation.

4.3.1 Fan Location and Direction

In general, exhausting air from the system chassis enclosure via a power supply fan at the rear panel is the preferred, most common, and most widely applicable system-level airflow solution. However, some system/chassis designers may choose to use other configurations to meet specific system cooling requirements.

4.3.2 Fan Size and Speed

A thermally sensitive fan speed control circuit is recommended to balance system-level thermal and acoustic performance. The circuit typically senses the temperature of the secondary heatsink and/or incoming ambient air and adjusts the fan speed as necessary to keep power supply and system component temperatures within specification. Both the power supply and system designers should be aware of the dependencies of the power supply and system temperatures on the control circuit response curve and fan size and should specify them carefully.

The power supply fan should be turned off when PS_ON# is de-asserted (high). In this state, any remaining active power supply circuitry must rely only on passive convection for cooling.

4.3.3 Venting

In general, more venting in a power supply case yields reduced airflow impedance and improved cooling performance. Intake and exhaust vents should be large, open, and unobstructed as possible so as not to impede airflow or generate excessive acoustic noise. In particular, avoid placing objects within 0.5 inches of the intake or exhaust of the fan itself. A flush-mount wire fan grill can be used instead of a stamped metal vent for improved airflow and reduced acoustic noise.

The limitations to the venting guidelines above are:

- Openings must be sufficiently designed to meet the safety requirements described in Chapter 8.
- Larger openings yield decreased EMI-shielding performance (see Chapter 7).
- Venting in inappropriate locations can detrimentally allow airflow to bypass those areas where it is needed.



5 Acoustics

5.1 Acoustics – RECOMMENDED

It is recommended that the power supply be designed with an appropriate fan, internal impedance, and fan speed control circuitry capable of meeting the acoustic targets listed in Table 21.

The power supply assembly shall not produce a prominent discrete tone determined according to ISO 7779, Annex D.

Sound power determination is to be performed at 43 C, at 50% of the maximum rated load, at sea level. This test point is chosen to represent the environment seen inside a typical system at the idle acoustic test condition, with the 43 C being derived from the standard ambient assumption of 23 C, with 20 C added for the temperature rise within the system (what is typically seen by the inlet fan). The declared sound power shall be measured according to ISO 7779 and reported according to ISO 9296.

Table 21 Recommended Power Supply Acoustic Targets

	Idle (BA)	Typical (50% load) (BA)	Maximum (BA)
Minimum	3.5	4.0	5.0
Target	3.0	3.8	4.5

§



6 *Environmental*

The following subsections define environmental specifications and test parameters, based on the typical conditions to which a power supply may be subjected during operation or shipment.

6.1 **Temperature – RECOMMENDED**

- Operating ambient +10 °C to +50 °C (At full load, with a maximum temperature rate of change of 5 °C/10 minutes, but no more than 10 °C/hr.)
- Non-operating ambient -40 °C to +70 °C (Maximum temperature rate of change of 20 °C/hr.)

6.2 **Thermal Shock (Shipping)**

- Non-operating -40 °C to +70 °C
- $15\text{ °C/min} \leq dT/dt \leq 30\text{ °C/min}$
- Tested for 50 cycles; Duration of exposure to temperature extremes for each half cycle shall be 30 minutes.

6.3 **Humidity – RECOMMENDED**

- Operating To 85% relative humidity (non-condensing)
- Non-operating To 95% relative humidity (non-condensing)
- Note: 95% relative humidity is achieved with a dry bulb temperature of 55 °C and a wet bulb temperature of 54 °C.

6.4 **Altitude – RECOMMENDED**

- Operating To 10,000 ft
- Non-operating To 50,000 ft

6.5 **Mechanical Shock – RECOMMENDED**

- Non-operating 50 g, trapezoidal input; velocity change ≥ 170 in/s
- Three drops on each of six faces are applied to each sample.

6.6 **Random Vibration – RECOMMENDED**

- Non-operating 0.01 g²/Hz at 5 Hz, sloping to 0.02 g²/Hz at 20 Hz, and maintaining 0.02 g²/Hz from 20 Hz to 500 Hz. The area under the PSD curve is 3.13 gRMS. The duration shall be 10 minutes per axis for all three axes on all samples.

• §



7 **Electromagnetic Compatibility**

The following subsections outline applicable product regulatory requirements for the power supplies. Additional requirements may apply dependent upon the design, product end use, target geography, and other variables.

7.1 **Emissions – REQUIRED**

The power supply shall comply with FCC Part 15, EN55022 and CISPR 22, 5th ed., meeting Class B for both conducted and radiated emissions with a 4 dB margin. Tests shall be conducted using a shielded DC output cable to a shielded load. The load shall be adjusted as follows for three tests: No load on each output; 50% load on each output; 100% load on each output. Tests will be performed at 100 VAC 50Hz, 120 VAC 60 Hz, and 230 VAC 50 Hz power. Additionally, for FCC certification purposes, the power supply shall be tested using the methods in 47 CFR 15.32(b) and authorized under the Declaration of Conformity process as defined in 47 CFR 2.906 using the process in 47 CFR 2.1071 through 47 CFR 2.1077.

7.2 **Immunity - REQUIRED**

The power supply shall comply with EN 55024 and CISPR 24 prior to sale in the EU (European Union), Korea, and possibly other geographies.

7.3 **Input Line Current Harmonic Content - OPTIONAL**

Class D harmonic limits will be determined at the time of measurement based on the actual power draw from the mains.

Table 22 is a partial list of countries and their current EMC requirements. Additional requirements may apply dependent upon the design, product end use, target geography, and other variables.

Table 22 EMC Requirement by Country

Country	Requirements Document
EU (European Union)	EN61000-3-2
Japan	JEIDA MITI
China	CCC & GB 17625.1
Russia	GOST R 51317.3.2

7.4 **Magnetic Leakage Field - REQUIRED**

A PFC choke magnetic leakage field should not cause any interference with a high-resolution computer monitor placed next to or on top of the end-use chassis.



7.5 Voltage Fluctuations and Flicker – REQUIRED

The power supply shall meet the specified limits of EN61000-3-3 (IEC 61000-3-3) and amendment A1 to EN 61000-3-3 (IEC 61000-3-3/A1) for voltage fluctuations and flicker for equipment drawing not more than 16AAC, connected to low voltage distribution systems.

§



8 Safety

The following subsections outline sample product regulations requirements for a typical power supply. Actual requirements will depend on the design, product end use, target geography, and other variables. Consult your company's Product Safety and Regulations department or an accredited third party certification agency for more details.

8.1 North America – REQUIRED

The power supply must be certified by an NRTL (Nationally Recognized Testing Laboratory) for use in the USA and Canada under the following conditions:

- The power supply UL report "Conditions of Acceptability" shall meet in the intended application of the power supply in the end product.
- The supply must be recognized for use in Information Technology Equipment including Electrical Business Equipment per UL 60950-1 First Edition. The certification must include external enclosure testing for the AC receptacle side of the power supply.
- The supply must have a full complement of tests conducted as part of the certification, such as input current, leakage current, hi-pot, temperature, energy discharge test, transformer output characterization test (open-circuit voltage, short-circuit performance), and abnormal testing (to include stalled-fan tests and voltage-select-switch mismatch).
- The enclosure must meet fire enclosure mechanical test requirements per clauses 2.9.1 and 4.2 of the above-mentioned standard.
- Production hi-pot testing must be included as a part of the certification and indicated as such in the certification report.
- There must not be unusual or difficult conditions of acceptability such as mandatory additional cooling or power de-rating. The insulation system shall not have temperatures exceeding their rating when tested in the end product.
- The certification mark shall be marked on each power supply.
- The power supply must be evaluated for operator-accessible secondary outputs (reinforced insulation) that meet the requirements for SELV.
- The proper polarity between the AC input receptacle and any printed wiring boards connections must be maintained (that is, brown=line, blue=neutral, and green=earth/chassis).
- The fan shall be protected by a guard to prevent contact by a finger in compliance with UL accessibility requirements.

8.2 International – REQUIRED

The vendor must provide a complete CB certificate and test report to IEC 60950-1. The CB report must include ALL CB member country national deviations as appropriate for the target market. All evaluations and certifications must be for reinforced insulation between primary and secondary circuits.



The power supply must meet the RoHS requirements for the European Union, Peoples Republic of China and other countries which have adopted the RoHS requirements for banned materials.

8.3 Proscribed Materials

The following materials must not be used during design and/or manufacturing of this product:

- Cadmium should not be used in painting or plating - REQUIRED.
- Quaternary salt and PCB electrolytic capacitors shall not be used - REQUIRED.
- CFC's or HFC's shall not be used in the design or manufacturing process - REQUIRED.
- Mercury shall not be used - REQUIRED.
- Some geographies require lead free or RoHS compliant power supplies - REQUIRED.

8.4 Catastrophic Failure Protection - RECOMMENDED

Should a component failure occur, the power supply should not exhibit any of the following :

- Flame
- Excessive smoke
- Charred PCB
- Fused PCB conductor
- Startling noise
- Emission of molten material
- Earth ground fault (short circuit to ground or chassis enclosure)

§



9 ***Reliability***

9.1 **Reliability - RECOMMENDED**

The de-rating process promotes quality and high reliability. All electronic components should be designed with conservative device de-ratings for use in commercial and industrial environments.

Electrolytic capacitor and fan lifetime and reliability should be considered in the design as well.

10 CFX12V Specific Guidelines 1.5

For Compact Form Factor with 12-volt connector power supplies.

10.1 Physical Dimensions – REQUIRED

The power supply shall be enclosed and meet the physical outline shown in Figure 7

Figure 7 CFX12V Mechanical Outline

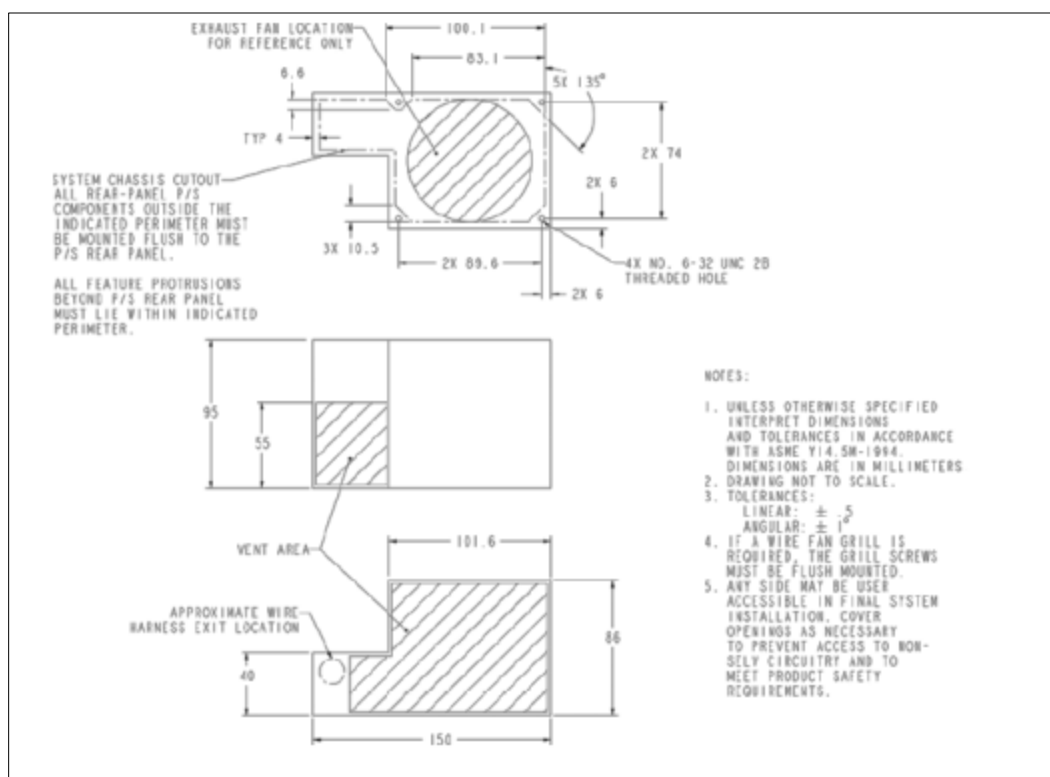

§

11 *LFX12V Specific Guidelines 1.3*

For Low Profile Form Factor with 12-volt connector power supplies.

11.1 Physical Dimensions - REQUIRED

The power supply shall be enclosed and meet the physical outline shown in Figure 8, applicable. Mechanical details are shown in Figure 9. Details on the power supply slot feature are shown in Figure 10. The recommended chassis slot feature details are shown in Figure 11.

Figure 8 Mechanical Outline

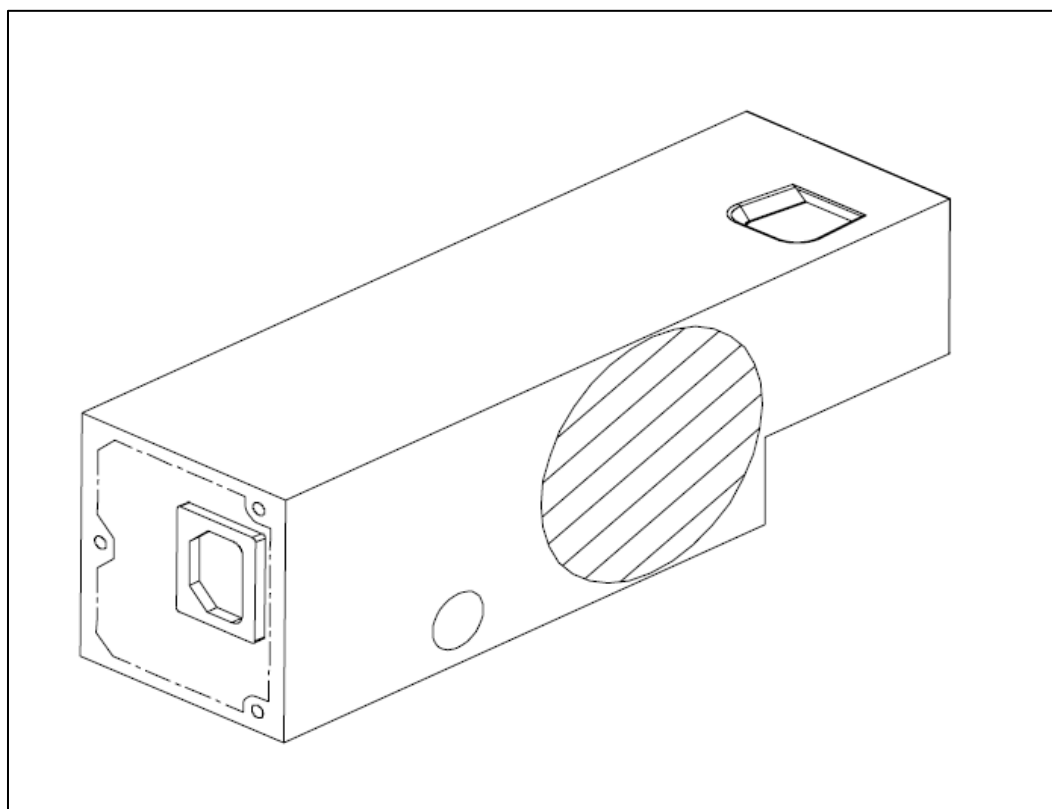

Figure 9 Mechanical Details

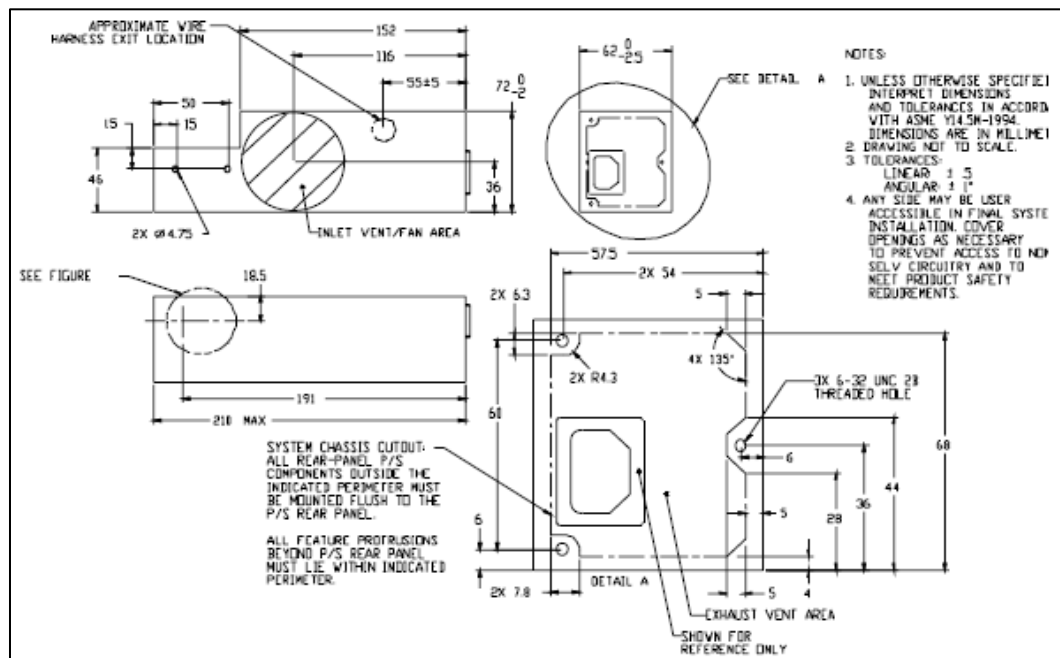

Figure 10 PSU Slot Feature Detail

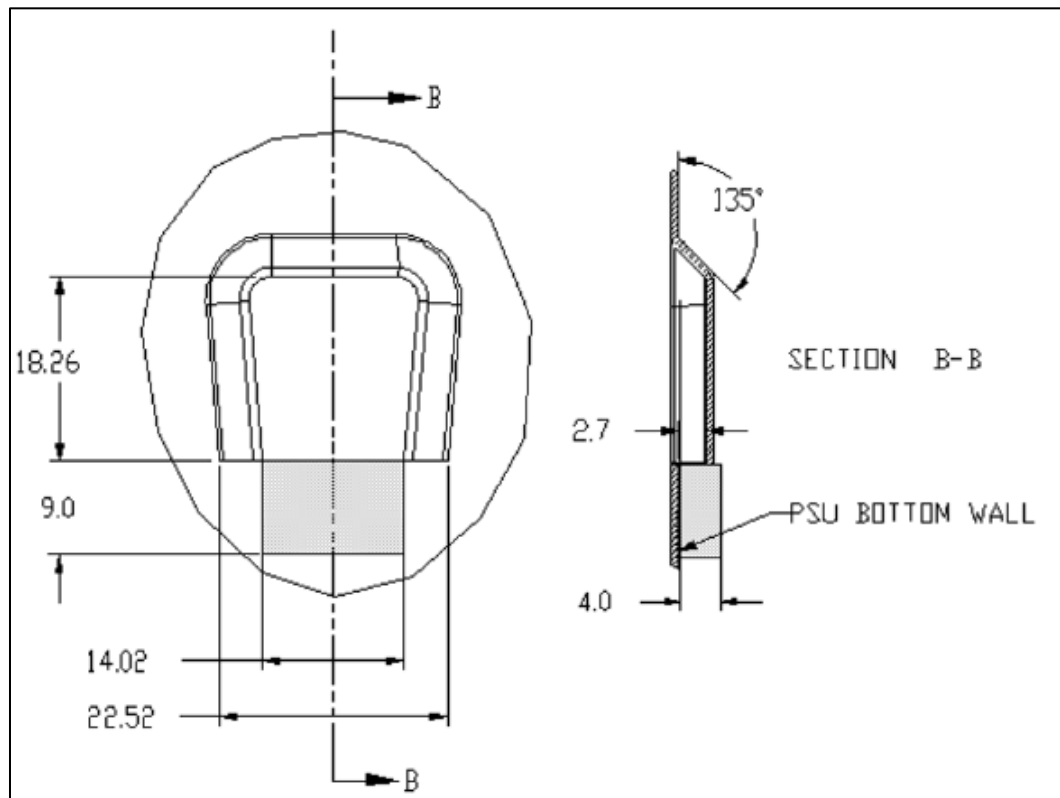
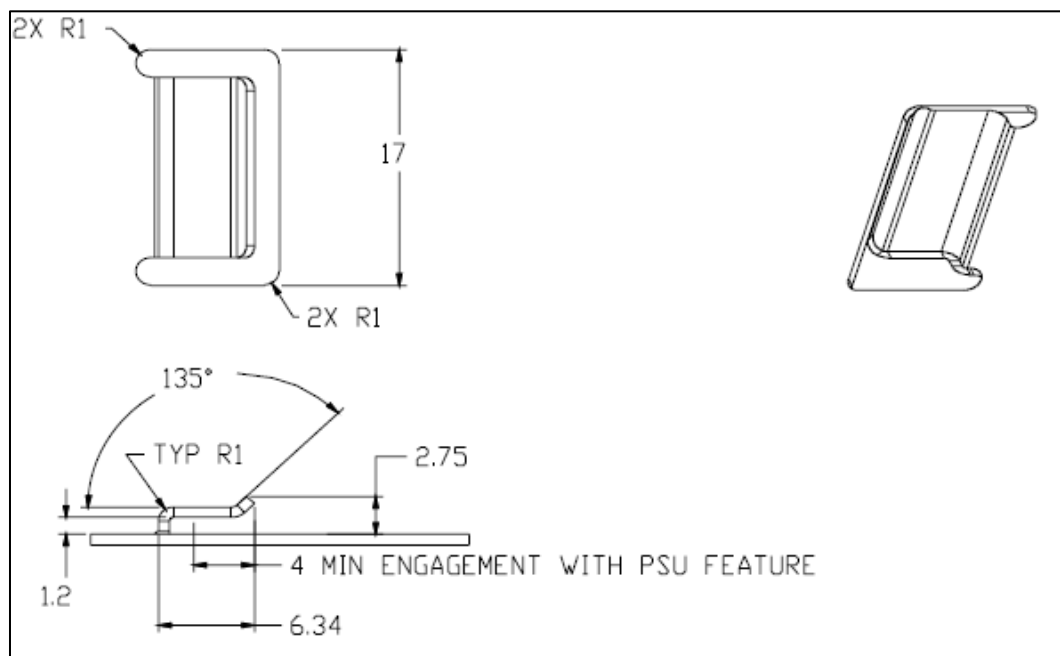

Figure 11 Recommended Chassis Tab Feature



12 ATX12V Specific Guidelines 2.4

For ATX Form Factor with 12-volt connector power supplies.

Figure 12 Power Supply Dimensions for Chassis that does not Require Top Venting

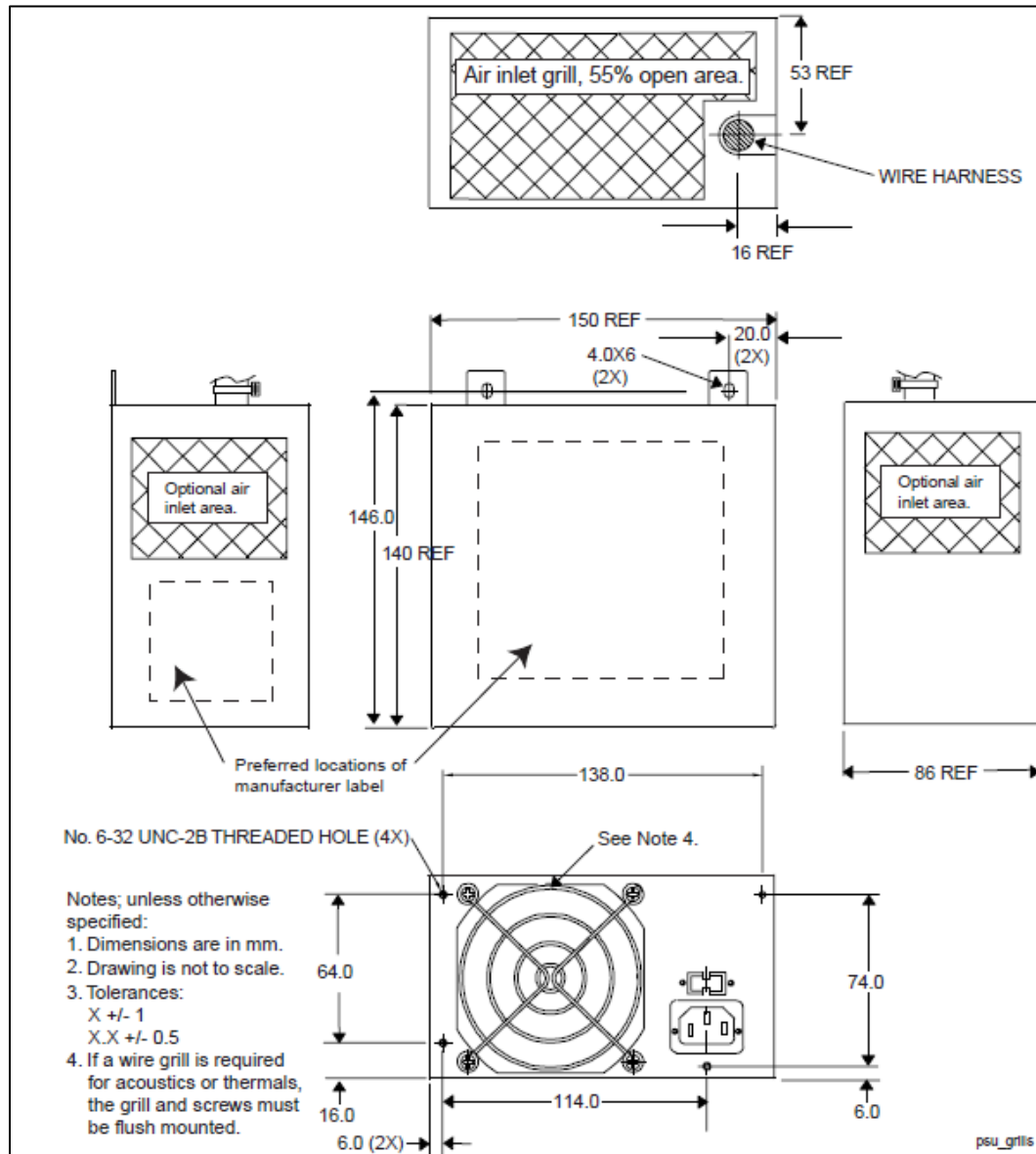
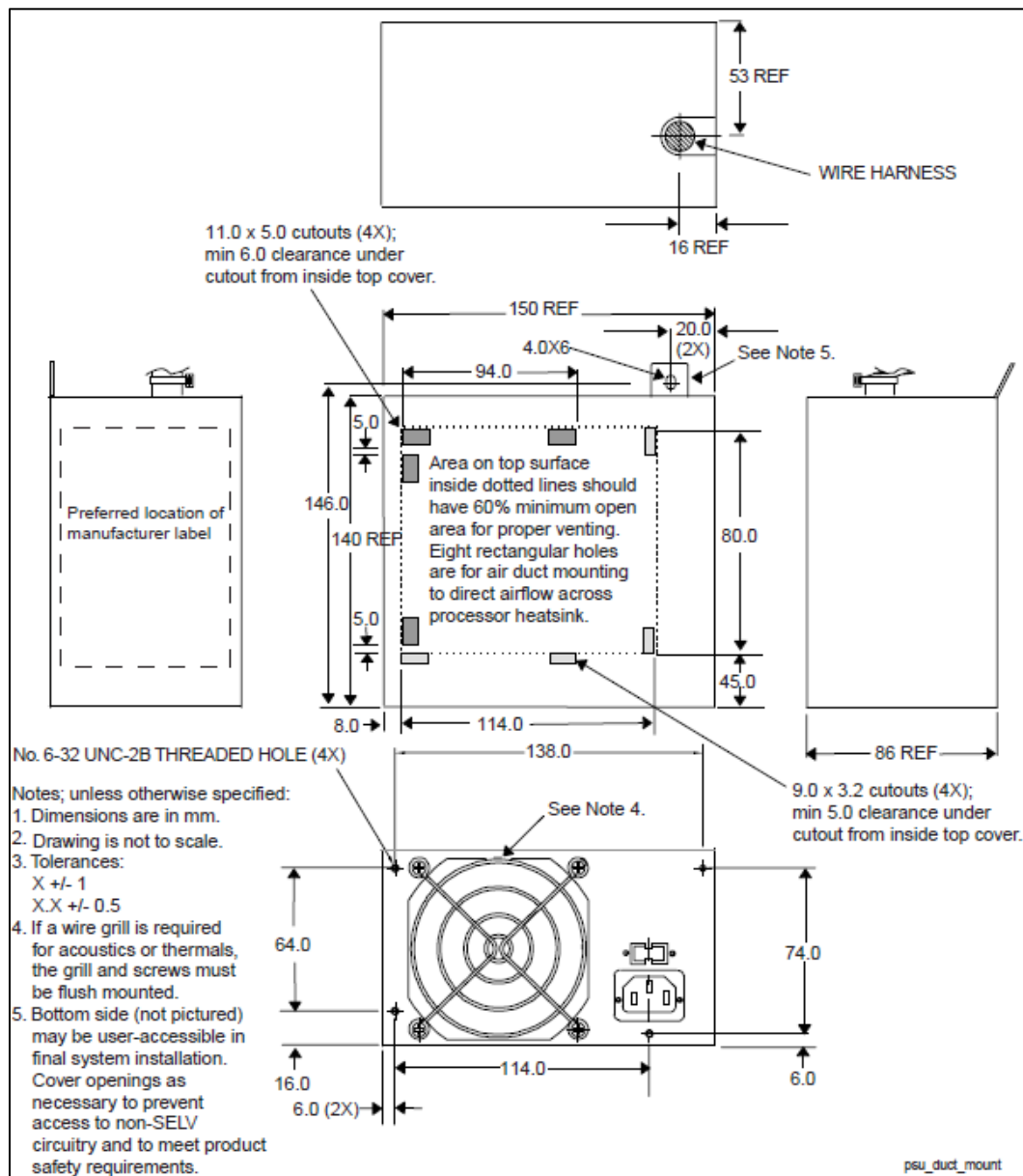

Figure 13 Power Supply Dimensions for Chassis that Require Top Venting





13 ***SFX12V Specific Guidelines 3.3***

For Small Form Factor with 12-volt connector power supplies.

13.1 **Lower Profile Package - Physical Dimensions - REQUIRED**

The power supply shall be enclosed and meet the physical outline shown in Figure 14.

13.2 **Fan Requirements - REQUIRED**

The fan will draw air from the computer system cavity pressurizing the power supply enclosure. The power supply enclosure shall exhaust the air through a grill located on the rear panel. See Figure 15. The movement of the fan to the computer system cavity is to help limit the acoustic noise of the unit.

The fan will be 40 mm.

Figure 14 40 mm Profile Mechanical Outline

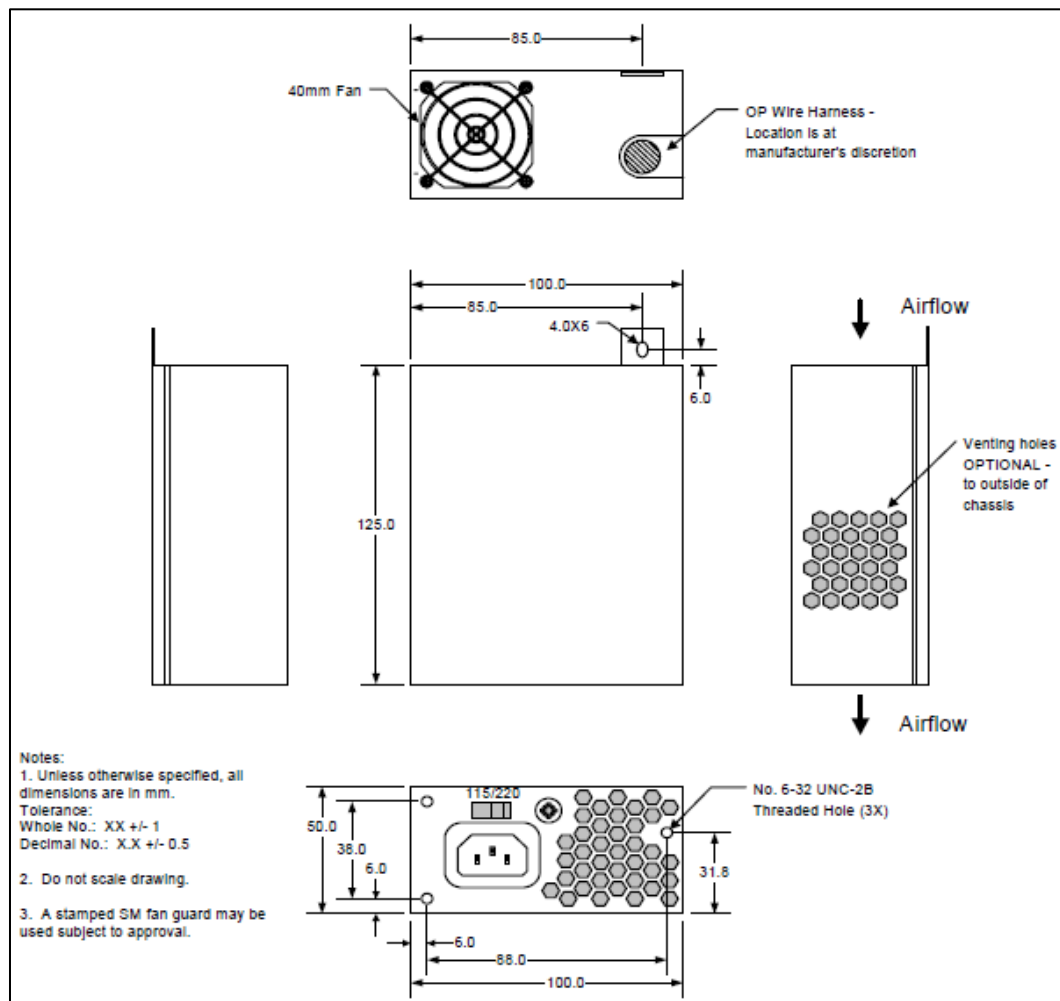
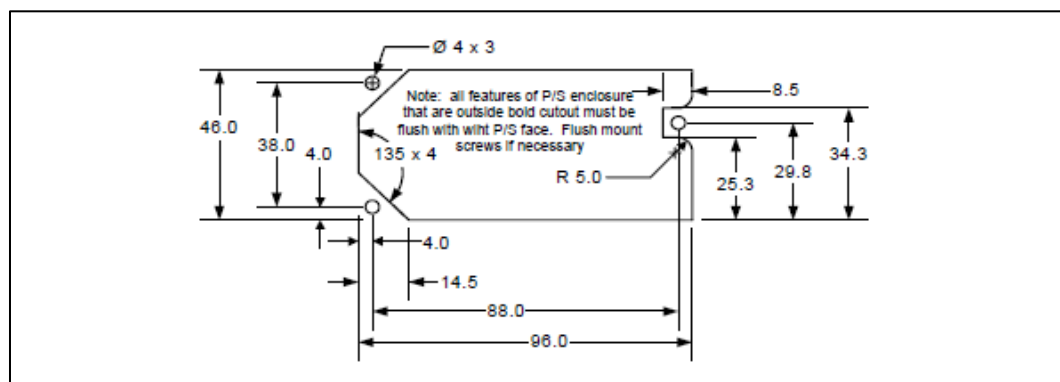

Figure 15 Chassis Cutout





13.3 Top Fan Mount Package - Physical Dimensions - REQUIRED

The power supply shall be enclosed and meet the physical outline shown in Figure 16.

13.4 Fan Requirements - REQUIRED

The fan will draw air from the computer system cavity pressurizing the power supply enclosure. The power supply enclosure shall exhaust the air through a grill located on the rear panel. See Figure 17. Moving the fan to the computer system cavity helps to limit the acoustic noise of the unit.

The fan will be 80mm.

To prevent damage to the fan during shipment and handling, the power supply designer should consider recessing the fan mounting, as shown in Figure 18.

Figure 16 Top Mount Fan Profile Mechanical Outline

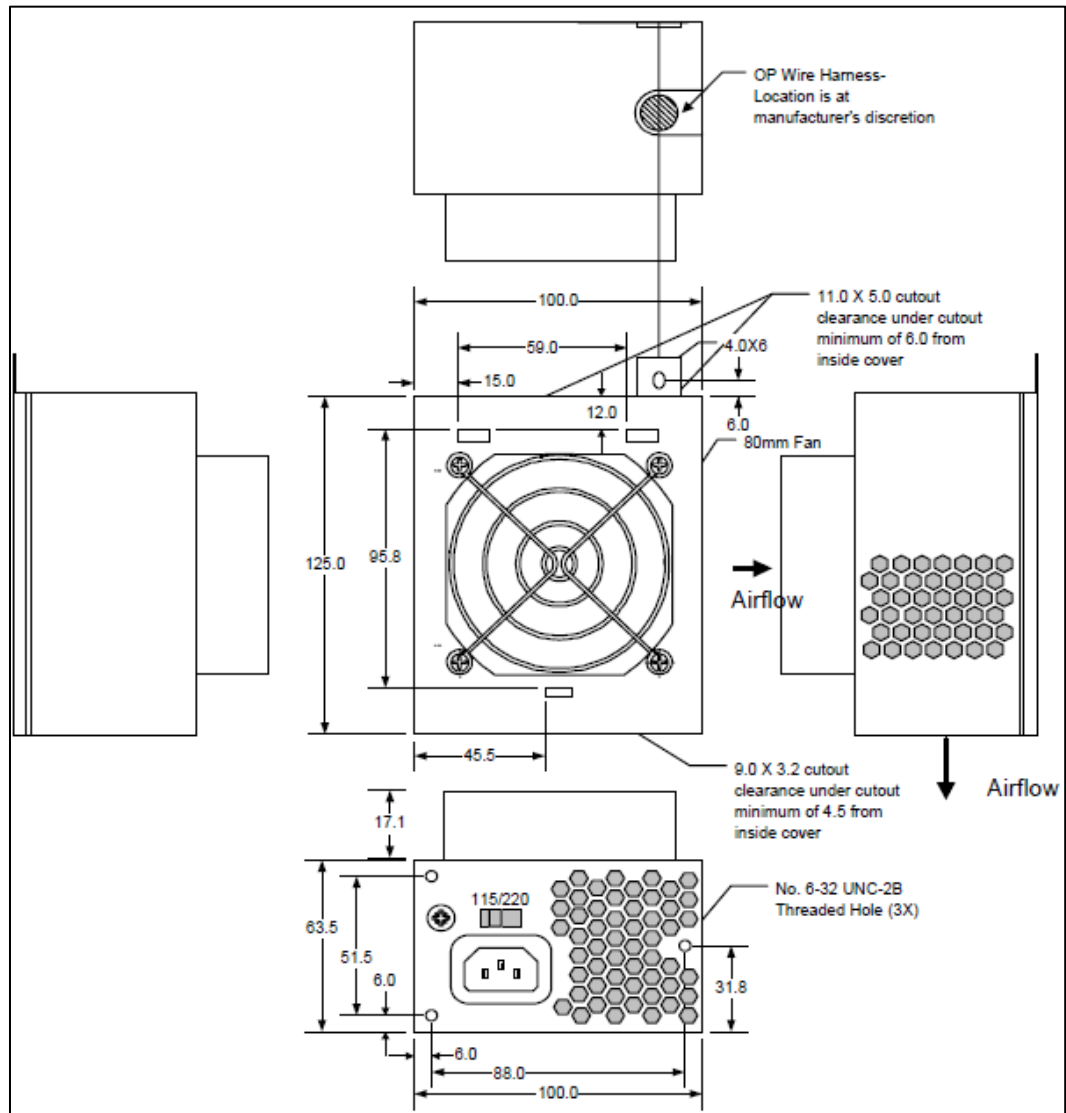

Figure 17 Chassis Cutout

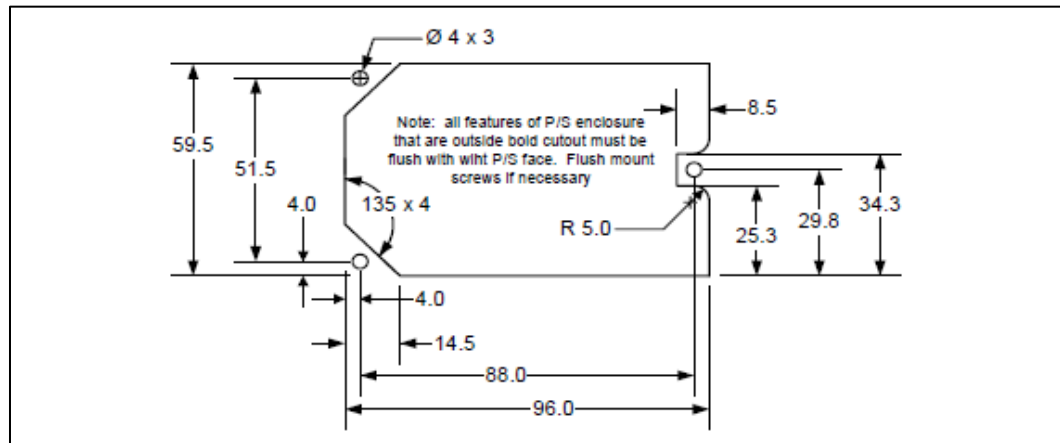
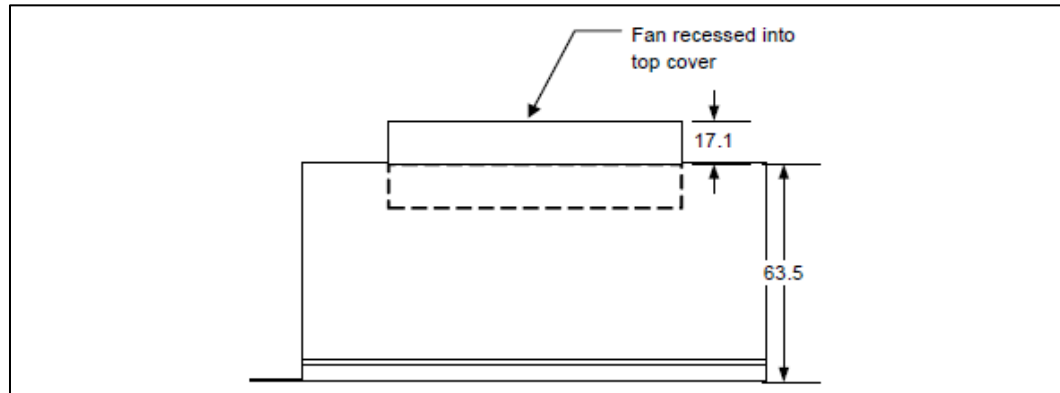

Figure 18 Recessed Fan Mounting



13.5 Reduced Depth Top Mount Fan - Physical Dimensions - REQUIRED

The power supply shall be enclosed and meet the physical outline shown in Figure 19.

13.6 Fan Requirements - REQUIRED

The fan will draw air from the computer system cavity pressurizing the power supply enclosure. The power supply enclosure shall exhaust the air through a grill located on the rear panel. See Figure 20. Moving the fan to the computer system cavity helps to limit the acoustic noise of the unit.

The fan will be 80 mm.

Figure 19 Reduced Depth Top Mount Fan Profile Mechanical Outline

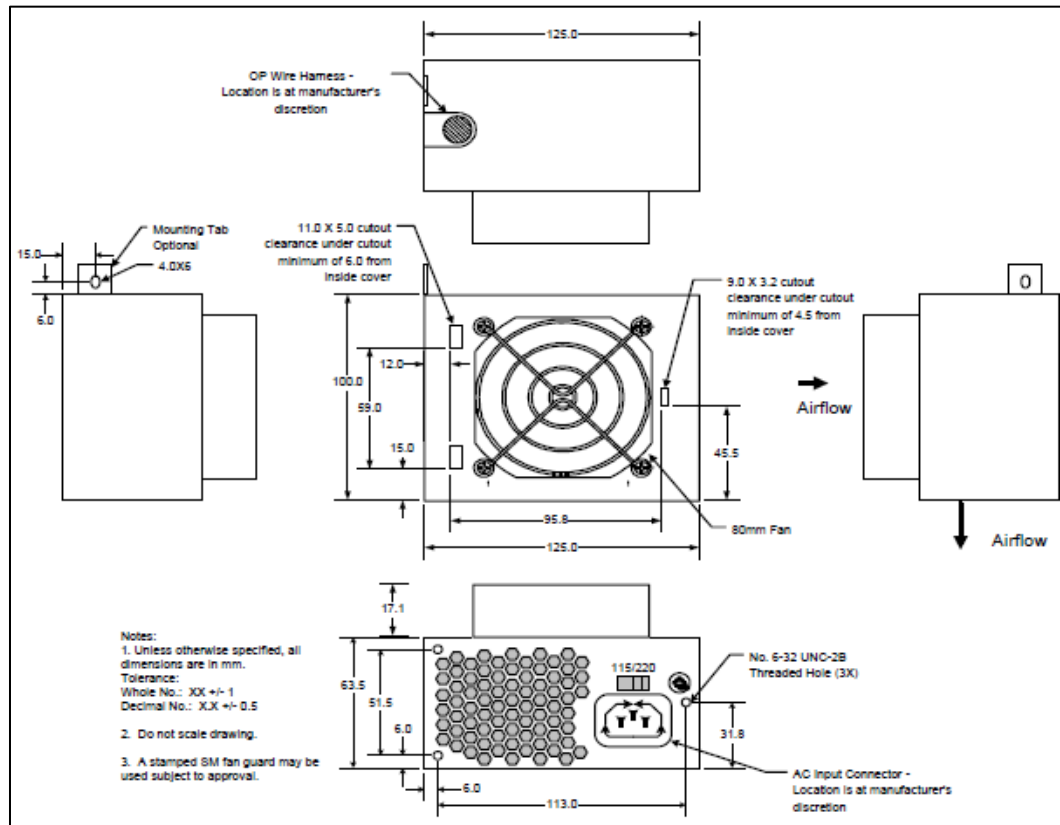
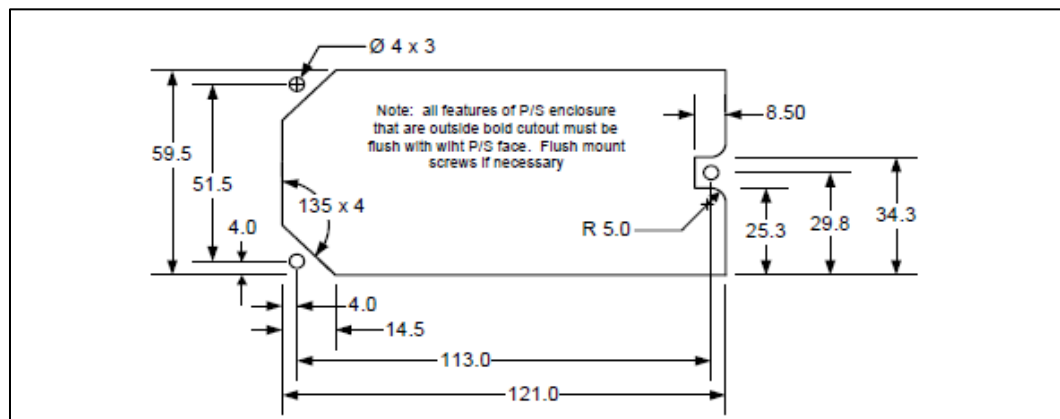

Figure 20 Chassis Cutout



13.7 Standard SFX Profile Package – Physical Dimensions - REQUIRED

The power supply shall be enclosed and meet the physical outline shown in Figure 21.

13.8 Fan Requirements - REQUIRED

The fan will draw air from the computer system cavity pressurizing the power supply enclosure. The power supply enclosure shall exhaust the air through a grill located on the rear panel. See Figure 22. The movement of the fan to the computer system cavity is to help limit the acoustic noise of the unit.

The fan will be 60 mm.

Figure 21 60 mm Mechanical Outline

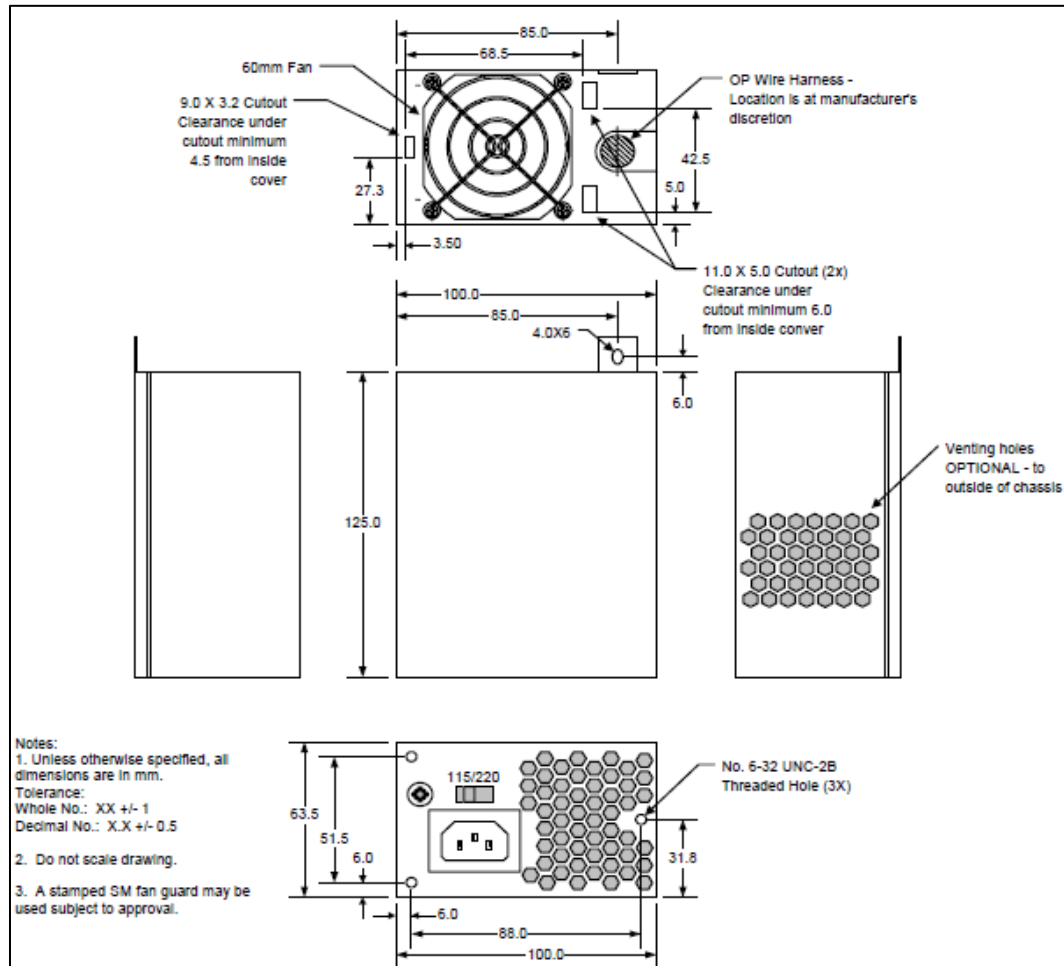
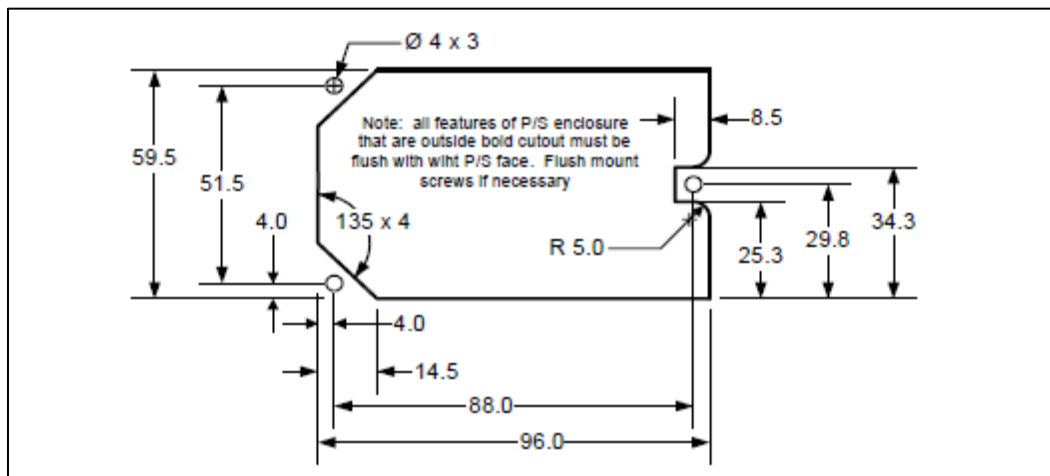

Figure 22 Chassis Cutout



13.9 PS3 Form Factor- Physical Dimensions - REQUIRED

The power supply shall be enclosed and meet the physical outline shown in Figure 23.

13.10 Fan Requirements - REQUIRED

An 80 mm axial fan is typically needed to provide enough cooling airflow through a high performance Micro ATX system. Exact CFM requirements vary by application and endues environment, but 25-35 CFM is typical for the fan itself.

For consumer or other noise-sensitive applications, it is recommended that a thermally sensitive fan speed control circuit be used to balance system-level thermal and acoustic performance. The circuit typically senses the temperature of an internal heatsink and/or incoming ambient air and adjusts the fan speed as necessary to keep power supply and system component temperatures within specification. Both the power supply and system designers should be aware of the dependencies of the power supply and system temperatures on the control circuit response curve and fan size and should specify them very carefully.

The power supply fan should be turned off when PS_ON# is de-asserted (high). In this state, any remaining active power supply circuitry must rely only on passive convection for cooling.

Figure 23 PS3 Mechanical Outline

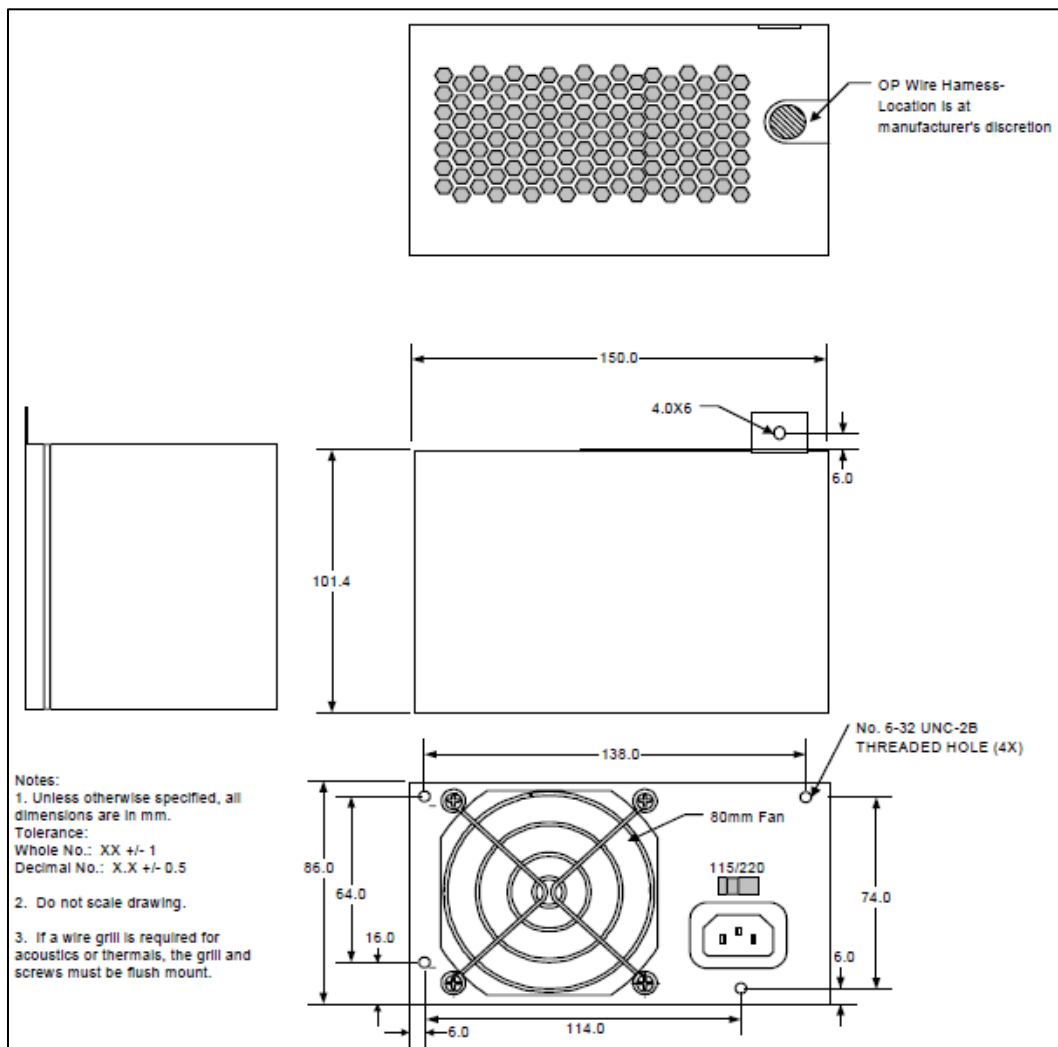

S

14 *TFX12V Specific Guidelines 2.4*

For Thin Form Factor with 12-volt connector power supplies.

14.1 Physical Dimensions - REQUIRED

Figure 24 Mechanical Outline

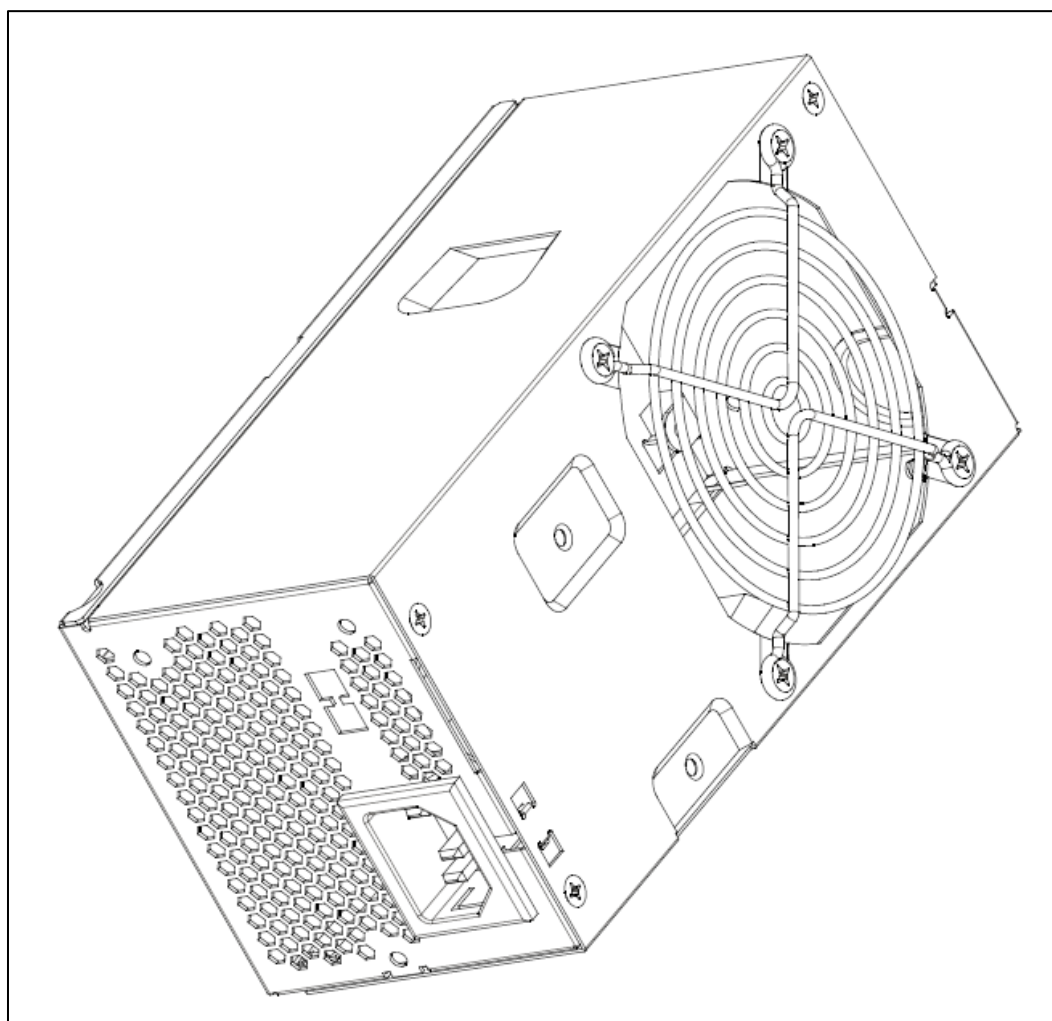

Figure 25 Dimensions & Recommended Feature Placements (not to scale)

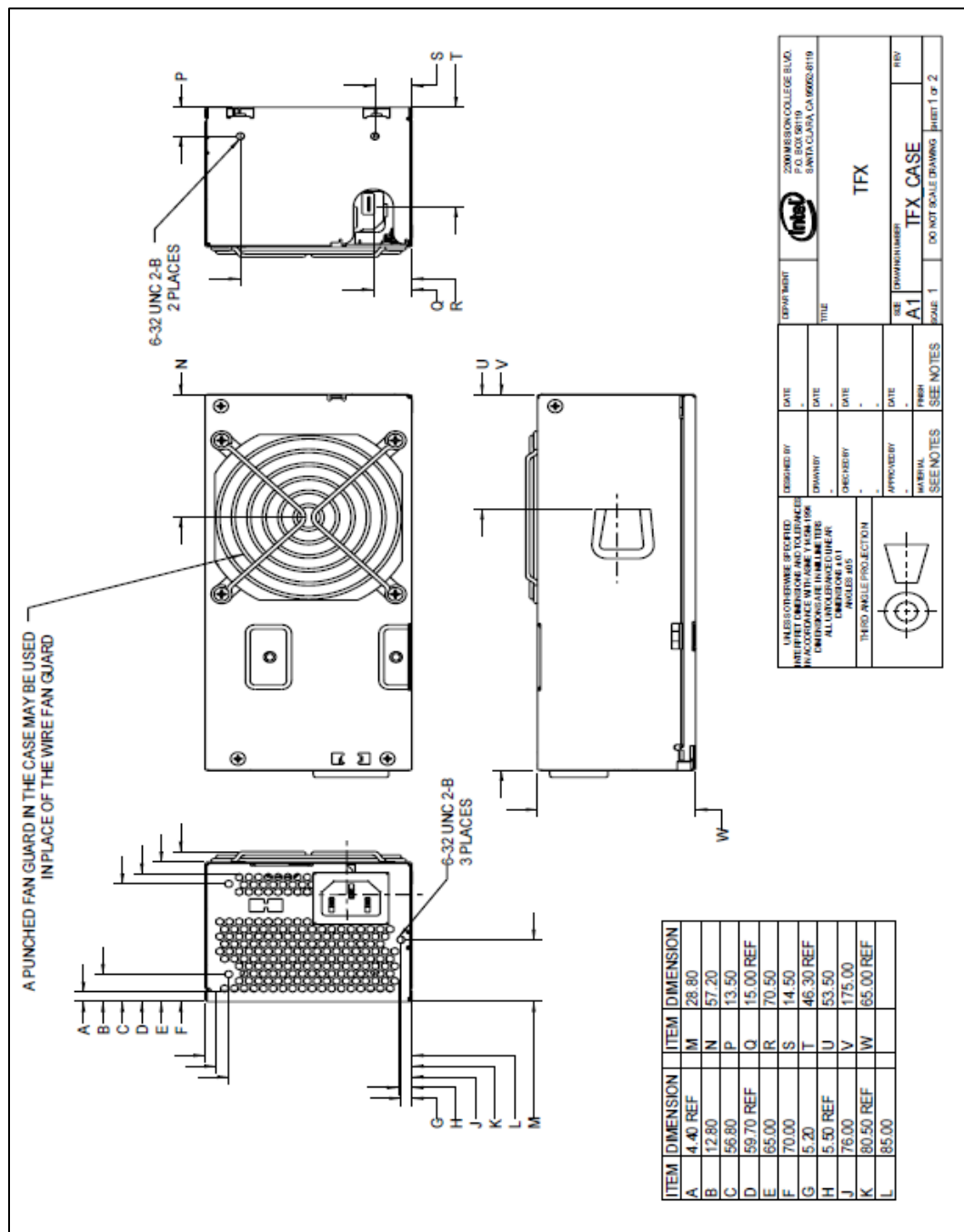
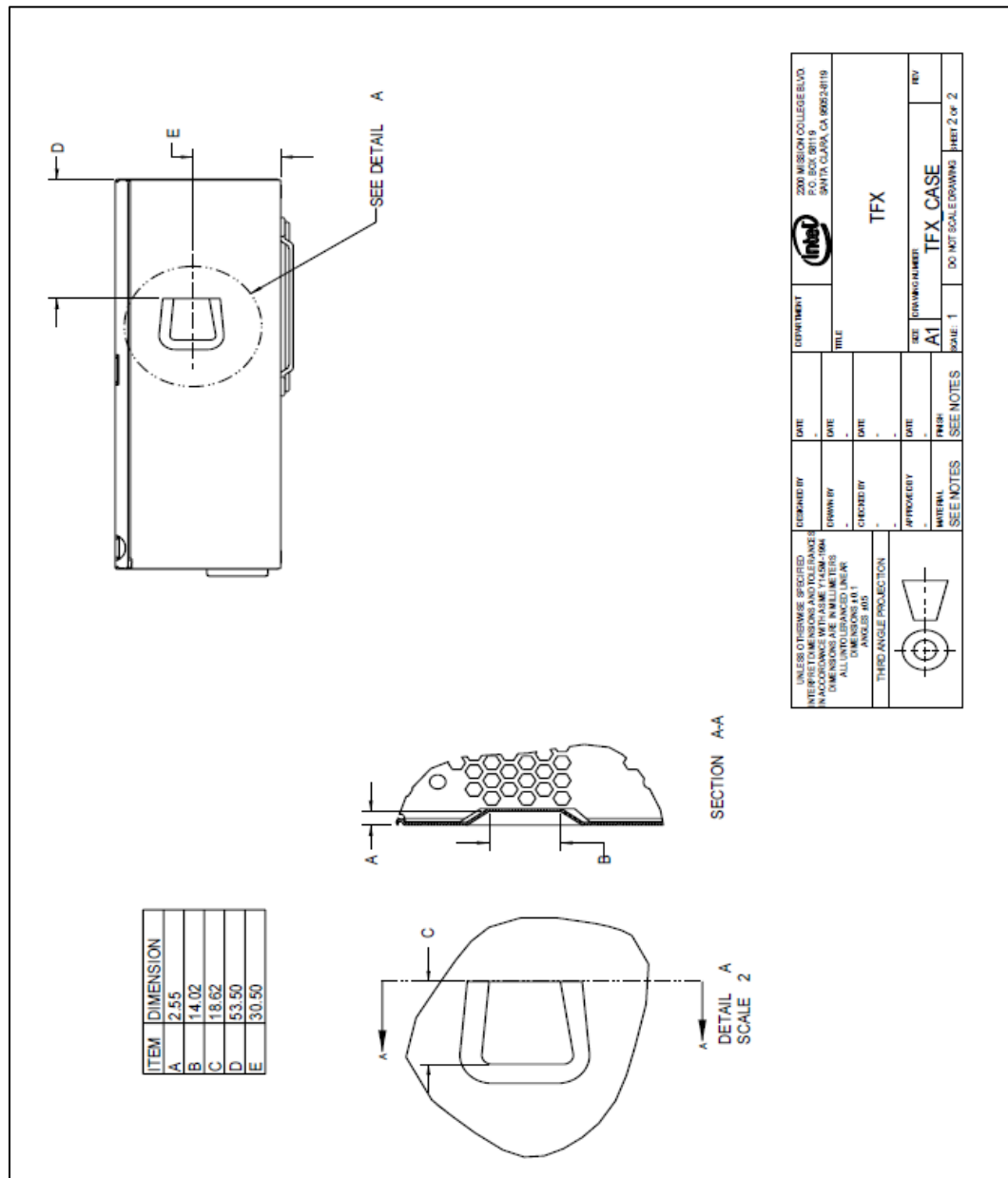

Figure 26 Power Supply Mounting Slot Detail



14.2 Mounting Options - RECOMMENDED

The TFX12V mechanical design provides two options for mounting in a system chassis. The unit can be mounted using one of the mounting holes on the front end (non-vented end) or a chassis feature can be designed to engage the slot provided in the bottom of the supply. In order to accommodate different system chassis layouts, the TFX12V power supply is also designed to mount in two orientations (fan left and fan right) as shown in Figure 27. A mounting hole and slot should be provided for each

orientation as shown in Figure 25. Details of a suggested geometry for the mounting slot are shown in Figure 26.

Figure 27 Fan Right and Fan Left Orientations of Power Supply in a Chassis

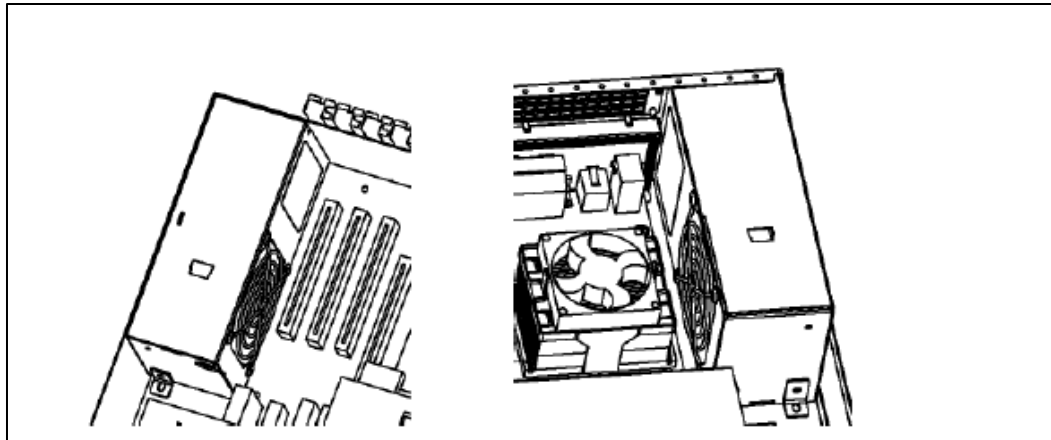

14.3 Chassis Requirements - RECOMMENDED

To ensure the power supply can be easily integrated, the following features should be designed into a chassis intended to use a TFX12V power supply:

- Chassis cutout (normally in the rear panel of the chassis) as shown in Figure 28.
- EITHER a mounting bracket to interface with the forward mounting hole on the power supply OR a mounting tab as shown in Figure 29 to interface with the mounting slot on the bottom of the power supply.

Figure 28 Suggested TFX12V Chassis Cut out

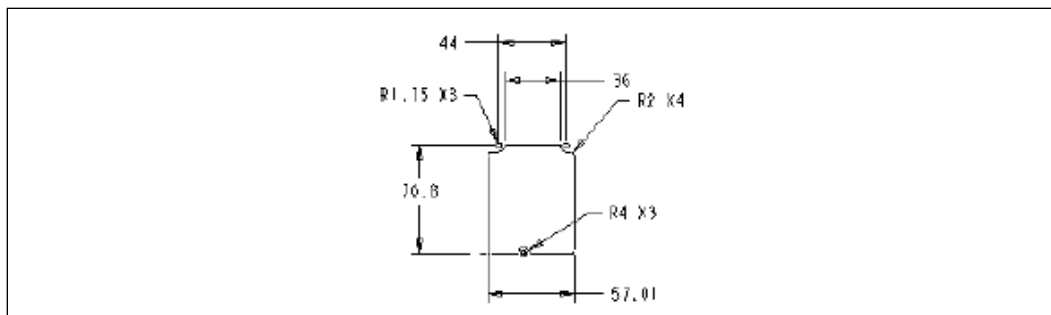
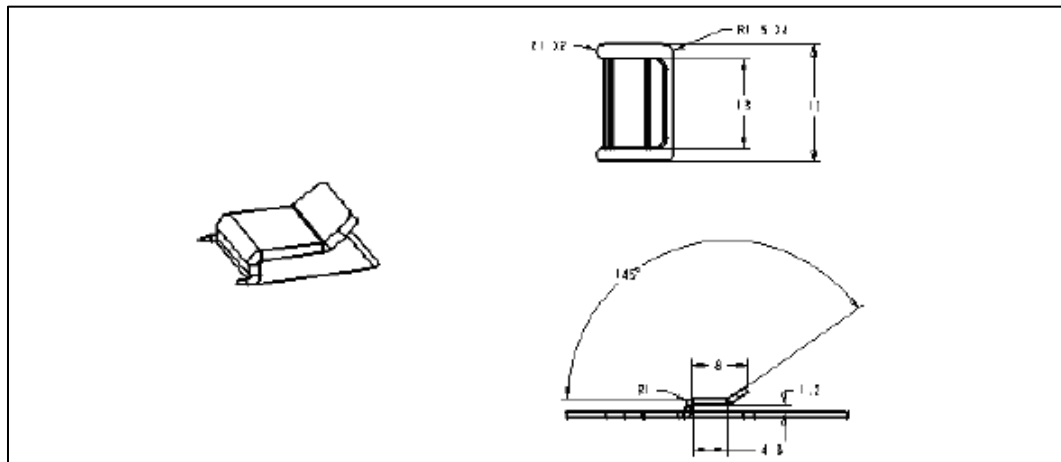

Figure 29 Suggested Mounting Tab (chassis feature)



15 Flex ATX Specific Guidelines 1.1

For Flex ATX Form Factor with 12-volt connector power supplies.

15.1 Physical Dimensions – REQUIRED

Figure 30 Mechanical Outline

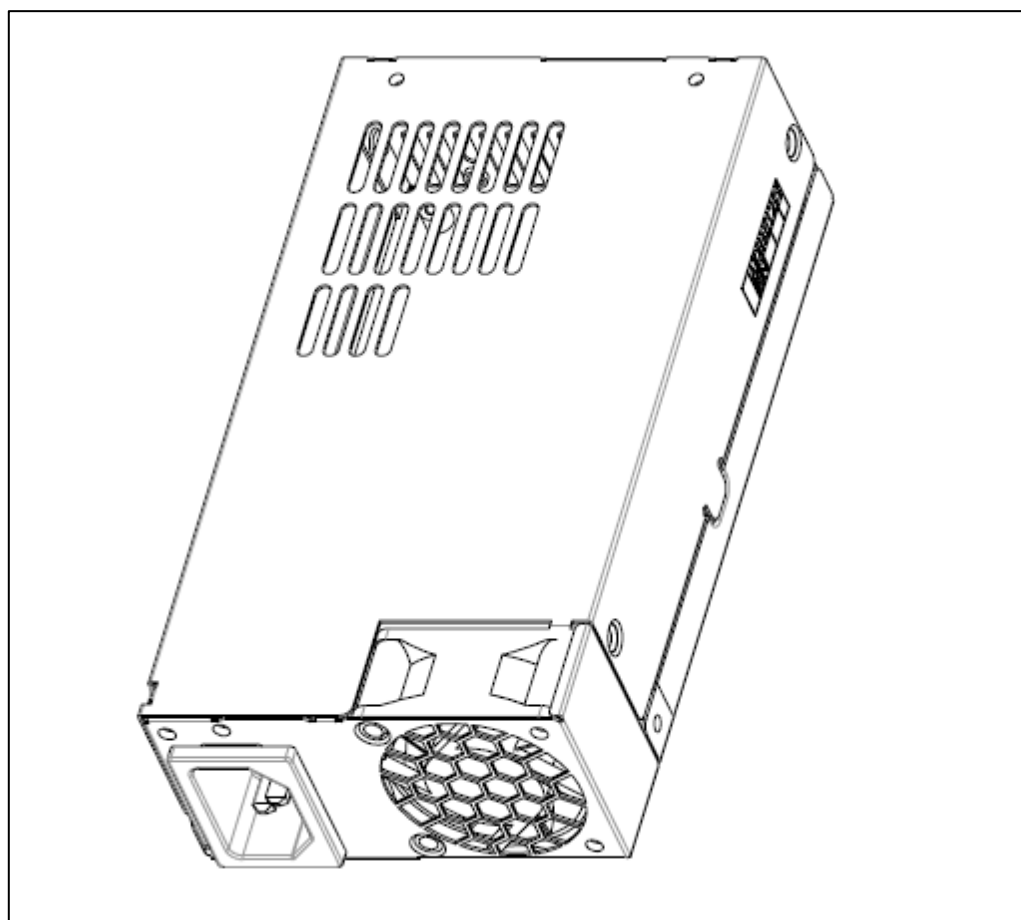



Figure 31 Dimensions & Recommended Feature Placements (not to scale)

