

Power Supply

Design Guide for Desktop Platform Form Factors

Revision 1.2

February 2008



INFORMATION IN THIS DOCUMENT IS PROVIDED IN CONNECTION WITH INTEL® PRODUCTS. NO LICENSE, EXPRESS OR IMPLIED, BY ESTOPPEL OR OTHERWISE, TO ANY INTELLECTUAL PROPERTY RIGHTS IS GRANTED BY THIS DOCUMENT. EXCEPT AS PROVIDED IN INTEL'S TERMS AND CONDITIONS OF SALE FOR SUCH PRODUCTS, INTEL ASSUMES NO LIABILITY WHATSOEVER, AND INTEL DISCLAIMS ANY EXPRESS OR IMPLIED WARRANTY, RELATING TO SALE AND/OR USE OF INTEL PRODUCTS INCLUDING LIABILITY OR WARRANTIES RELATING TO FITNESS FOR A PARTICULAR PURPOSE, MERCHANTABILITY, OR INFRINGEMENT OF ANY PATENT, COPYRIGHT OR OTHER INTELLECTUAL PROPERTY RIGHT. Intel products are not intended for use in medical, life saving, or life sustaining applications.

Intel may make changes to specifications and product descriptions at any time, without notice.

Designers must not rely on the absence or characteristics of any features or instructions marked "reserved" or "undefined." Intel reserves these for future definition and shall have no responsibility whatsoever for conflicts or incompatibilities arising from future changes to them.

This document contains information on products in the design phase of development. Do not finalize a design with this information. Revised information will be published when the product is available. Verify with your local sales office that you have the latest datasheet before finalizing a design.

Contact your local Intel sales office or your distributor to obtain the latest specifications and before placing your product order.

Hyper-Threading Technology requires a computer system with an Intel® Pentium® 4 processor supporting HT Technology and a Hyper-Threading Technology enabled chipset, BIOS and operating system. Performance will vary depending on the specific hardware and software you use. See <<http://www.intel.com/info/hyperthreading>> for more information including details on which processors support HT Technology

Intel, Celeron, Intel NetBurst, Xeon and the Intel logo are trademarks or registered trademarks of Intel Corporation or its subsidiaries in the United States and other countries.

*Other names and brands may be claimed as the property of others.

Copyright © 2007 - 2008, Intel Corporation.

*Other names and brands may be claimed as the property of others.



Contents

1	Introduction	9
1.1	Reference Documentation.....	9
1.2	Terminology	10
2	Platform Configurations	13
2.1	Digital Home and Digital Office Platform Configurations - RECOMMENDED	13
3	Electrical	19
3.1	AC Input - REQUIRED	19
3.1.1	Input Over Current Protection - REQUIRED	19
3.1.2	Inrush Current - REQUIRED	19
3.1.3	Input Under Voltage - REQUIRED	19
3.2	DC Output - REQUIRED	20
3.2.1	DC Voltage Regulation	20
3.2.2	Output Transient Response - REQUIRED	20
3.2.3	Remote Sensing - REQUIRED	21
3.2.4	Other Low Power System Requirements - RECOMMENDED	21
3.2.5	Output Ripple Noise - REQUIRED	21
3.2.6	Capacitive Load - REQUIRED.....	22
3.2.7	Closed Loop Stability - REQUIRED	22
3.2.8	+5 VDC / +3.3 VDC Power Sequencing - REQUIRED	23
3.2.9	Voltage Hold-up Time - REQUIRED	23
3.3	Timing, Housekeeping and Control - REQUIRED.....	23
3.3.1	PWR_OK	23
3.3.2	Power-up Cross Loading Condition	24
3.3.3	PS_ON#.....	24
3.3.4	+5 VSB.....	25
3.3.5	Power-on Time.....	25
3.3.6	Rise Time	26
3.3.7	Overshoot at Turn-on / Turn-off	26
3.4	Reset after Shutdown	26
3.4.1	+5 VSB at Power-down	26
3.5	Output Protection - REQUIRED	26
3.5.1	Over Voltage Protection.....	26
3.5.2	Short Circuit Protection	27
3.5.3	No-load Situation	27
3.5.4	Over Current Protection	27
3.5.5	Over Temperature Protection	27
3.5.6	Output Bypass	27
3.5.7	Separate Current Limit for 12V2 - RECOMMENDED.....	27
3.5.8	Overall Power Supply Efficiency and ENERGY STAR	28
3.5.9	Overall Power Supply Efficiency and Climate Savers§	30
4	Mechanical	33
4.1	Labeling and Marking - RECOMMENDED.....	33
4.2	Connectors - REQUIRED	33
4.2.1	AC Connector	33
4.2.2	DC Connectors.....	33
4.2.2.1	Main Power Connector	34
4.2.2.2	Peripheral Connectors.....	35
4.2.2.3	Floppy Drive Connector.....	35
4.2.2.4	+12 V Power Connector	36
4.2.2.5	Serial ATA* Power Connectors	36



4.3	Airflow and Fans - RECOMMENDED	37
4.3.1	Fan Location and Direction	37
4.3.2	Fan Size and Speed	37
4.3.3	Venting	38
5	Acoustics	39
5.1	Acoustics - RECOMMENDED	39
6	Environmental	41
6.1	Temperature - RECOMMENDED	41
6.1.1	Thermal Shock (Shipping)	41
6.2	Humidity - RECOMMENDED	41
6.3	Altitude - RECOMMENDED	41
6.4	Mechanical Shock - RECOMMENDED	41
6.5	Random Vibration - RECOMMENDED	41
7	Electromagnetic Compatibility	43
7.1	Emissions - REQUIRED	43
7.2	Immunity - REQUIRED	43
7.3	Input Line Current Harmonic Content - OPTIONAL	43
7.4	Magnetic Leakage Fields - REQUIRED	43
7.5	Voltage Fluctuations and Flicker - REQUIRED	44
8	Safety	45
8.1	North America - REQUIRED	45
8.2	International - REQUIRED	45
8.3	Proscribed Materials	46
8.4	Catastrophic Failure Protection - RECOMMENDED	46
9	Reliability	47
9.1	Reliability - RECOMMENDED	47
10	CFX12V Specific Guidelines 1.41	49
10.1	Typical Power Distribution - RECOMMENDED	49
10.2	Physical Dimensions - REQUIRED	53
11	LFX12V Specific Guidelines 1.21	55
11.1	Typical Power Distribution - RECOMMENDED	55
11.2	Physical Dimensions - REQUIRED	58
12	ATX12V Specific Guidelines 2.31	63
12.1	Typical Power Distribution - RECOMMENDED	63
12.2	Physical Dimensions - REQUIRED	72
13	SFX12V Specific Guidelines 3.21	75
13.1	Typical Power Distribution - RECOMMENDED	75
13.2	Lower Profile Package - Physical Dimensions - REQUIRED	79
13.3	Fan Requirements - REQUIRED	79
13.4	Top Fan Mount Package - Physical Dimensions - REQUIRED	81
13.5	Fan Requirements - REQUIRED	81
13.6	Reduced Depth Top Mount Fan - Physical Dimensions - REQUIRED	83
13.7	Fan Requirements - REQUIRED	83
13.8	Standard SFX Profile Package - Physical Dimensions - REQUIRED	84
13.9	Fan Requirements - REQUIRED	85
13.10	PS3 Form Factor- Physical Dimensions - REQUIRED	86
13.11	Fan Requirements - REQUIRED	86
14	TFX12V Specific Guidelines 2.31	89
14.1	Typical Power Distribution - RECOMMENDED	89

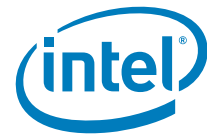

14.2	Physical Dimensions - REQUIRED	94
14.3	Mounting Options - RECOMMENDED	97
14.4	Chassis Requirements - RECOMMENDED	97
15	Flex ATX Specific Guidelines 1.01	99
15.1	Typical Power Distribution - RECOMMENDED	99
15.2	Physical Dimensions - REQUIRED	103

Figures

1	Differential Noise Test Setup	22
2	Power Supply Timing	23
3	PS_ON# Signal Characteristics	25
4	PSU Efficiency as Percentage of Output	28
5	PSU Efficiency per Power for 450 W PSU	29
6	PSU Efficiency per Power for 250 W PSU	30
7	Connectors (Pin-side view, not to scale)	34
8	Serial ATA* Power Connector	36
9	Cross Loading Graph for 180 W Configurations	49
10	Cross Loading Graph for 220 W Configurations	50
11	Cross Loading Graph for 270 W Configurations	51
12	Cross Loading Graph for 300 W Configurations	52
13	CFX12V Mechanical Outline	54
14	Cross Loading Graph for 180 W Configurations	55
15	Cross Loading Graph for 220 W Configurations	56
16	Cross Loading Graph for 270 W Configurations	57
17	Mechanical Outline	59
18	Mechanical Details	60
19	PSU Slot Feature Detail	60
20	Recommended Chassis Tab Feature	61
21	Cross Loading Graph for 180 W Configurations	63
22	Cross Loading Graph for 220 W Configurations	64
23	Cross Loading Graph for 270 W Configurations	65
24	Cross Loading Graph for 300 W Configurations	66
25	Cross Loading Graph for 350 W Configurations	67
26	Cross Loading Graph for 400 W Configurations	68
27	Cross Loading Graph for 450 W Configurations	69
28	Power Supply Dimensions for Chassis that does not Require Top Venting	72
29	Power Supply Dimensions for Chassis that Require Top Venting	73
30	Cross Loading Graph for 180 W Configurations	75
31	Cross Loading Graph for 220 W Configurations	76
32	Cross Loading Graph for 270 W Configuration	77
33	Cross Loading Graph for 300 W Configuration	78
34	40 mm Profile Mechanical Outline	80
35	Chassis Cutout	80
36	Top Mount Fan Profile Mechanical Outline	82
37	Chassis Cutout	83
38	Recessed Fan Mounting	83
39	Reduced Depth Top Mount Fan Profile Mechanical Outline	84
40	Chassis Cutout	84
41	60 mm Mechanical Outline	85
42	Chassis Cutout	86
43	PS3 Mechanical Outline	87
44	Cross Loading Graph for 180 W Configuration	89
45	Cross Loading Graph for 220 W Configurations	90



46	Cross Loading Graph for 270 W Configuration.....	91
47	Cross Loading Graph for 300 W Configuration.....	92
48	Mechanical Outline.....	94
49	Dimensions & Recommended Feature Placements (not to scale).....	95
50	Power Supply Mounting Slot Detail.....	96
51	Fan Right and Fan Left Orientations of Power Supply in a Chassis.....	97
52	Suggested TFX12V Chassis Cutout.....	97
53	Suggested Mounting Tab (chassis feature).....	98
54	Cross Loading Graph for 180 W Configuration.....	99
55	Cross Loading Graph for 220 W Configurations.....	100
56	Cross Loading Graph for 270 W Configuration.....	101
57	Mechanical Outline.....	103
58	Dimensions & Recommended Feature Placements (not to scale).....	104

Tables

1	Conventions and Terminology.....	10
2	Support Terminology.....	11
3	Digital Office Platform Configurations for 2008.....	13
4	Digital Home Platform Configurations for 2008.....	14
5	Digital Home Platform Configurations for 2007 - Lifestyle EPC Mainstream.....	14
7	Digital Home Platform Configurations for 2007 - Lifestyle EPC Premium.....	15
6	Digital Home Platform Configurations for 2007 - CE EPC.....	15
8	Digital Home Platform Configurations for 2007 - Extreme Gaming and Media.....	16
9	Digital Office Platform Configurations for 2007 - Entry.....	16
10	Digital Office Platform Configurations for 2007 - Fundamental.....	17
11	Digital Office Platform Configurations for 2007 - Professional.....	17
12	Digital Office Platform Configurations for 2007 - High Performance.....	17
13	12V2 Current for Processor Configurations.....	18
14	AC Input Line Requirements.....	19
15	DC Output Voltage Regulation.....	20
16	DC Output Transient Step Sizes.....	20
17	Recommended 5 VSB Efficiency.....	21
18	DC Output Noise/Ripple.....	21
19	Output Capacitive Loads.....	22
20	PWR_OK Signal Timing.....	24
21	PWR_OK Signal Characteristics.....	24
22	PS_ON# Signal Characteristics.....	25
23	Over Voltage Protection.....	26
24	Efficiency Versus Load.....	28
25	Power Supply Sizes for ENERGY STAR Desktop System Categories.....	30
26	Main Power Connector Pin-out.....	34
27	Peripheral Connector Pin-out.....	35
28	Floppy Connector Pin-out.....	35
29	+12 V Power Connector Pin-out.....	36
30	Serial ATA* Power Connector Pin-out.....	36
31	Recommended Power Supply Acoustic Targets.....	39
32	EMC Requirements by Country.....	43
33	Typical Power Distribution for 180 W Configurations.....	49
34	Typical Power Distribution for 220 W Configurations.....	50
35	Typical Power Distribution for 270 W Configurations.....	51
36	Typical Power Distribution for 300 W Configurations.....	52
37	180 W Loading for Efficiency Measurements.....	52



38	220 W Loading for Efficiency Measurements	53
39	270 W Loading for Efficiency Measurements	53
40	300 W Loading for Efficiency Measurements	53
41	Typical Power Distribution for 180 W Configurations	55
42	Typical Power Distribution for 220 W Configurations	56
43	Typical Power Distribution for 270 W Configurations	57
44	180 W Loading for Efficiency Measurements	57
45	220 W Loading for Efficiency Measurements	58
46	270 W Loading for Efficiency Measurements	58
47	Typical Power Distribution for 180 W Configurations	63
48	Typical Power Distribution for 220 W Configurations	64
49	Typical Power Distribution for 270 W Configurations	65
50	Typical Power Distribution for 300 W Configurations	66
51	Typical Power Distribution for 350 W Configurations	67
52	Typical Power Distribution for 400 W Configurations	68
53	Typical Power Distribution for 450 W Configurations	69
54	180 W Loading for Efficiency Measurements	69
55	220 W Loading for Efficiency Measurements	70
56	270 W Loading for Efficiency Measurements	70
57	300 W Loading for Efficiency Measurements	70
58	350 W Loading for Efficiency Measurements	70
59	400 W Loading for Efficiency Measurements	70
60	450 W Loading for Efficiency Measurements	71
61	Typical Power Distribution for 180 W Configurations	75
62	Typical Power Distribution for 220 W Configurations	76
63	Typical Power Distribution for 270 W Configurations	77
64	Typical Power Distribution for 300 W Configurations	78
65	180 W Loading for Efficiency Measurements	78
66	220 W Loading for Efficiency Measurements	79
67	270 W Loading for Efficiency Measurements	79
68	300 W Loading for Efficiency Measurements	79
69	Typical Power Distribution for 180 W Configurations	89
70	Typical Power Distribution for 220 W Configurations	90
71	Typical Power Distribution for 270 W Configurations	91
72	Typical Power Distribution for 300 W Configurations	92
73	180 W Loading for Efficiency Measurements	92
74	220 W Loading for Efficiency Measurements	93
75	270 W Loading for Efficiency Measurements	93
76	300 W Loading for Efficiency Measurements	93
77	Typical Power Distribution for 180 W Configurations	100
78	Typical Power Distribution for 220 W Configurations	100
79	Typical Power Distribution for 270 W Configurations	101
80	180 W Loading for Efficiency Measurements	101
81	220 W Loading for Efficiency Measurements	102
82	270 W Loading for Efficiency Measurements	102



Revision History

Revision	Description	Date
0.5	<ul style="list-style-type: none"> Initial release of combined power supply design guide Combined CFX12V, LFX12V, ATX12V, SFX12V, and TFX12V content into one desktop power supply design guide CFX12V content derived from revision 1.2 <ul style="list-style-type: none"> - Updated 12V1 current for 300 W configuration - Updated efficiency loading for 300 W configuration LFX12V content derived from revision 1.1 ATX12V content derived from revision 2.2 SFX12V content derived from revision 3.1 TFX12V content derived from revision 2.1 <ul style="list-style-type: none"> - Updated 12V1 current for 300 W configuration - Updated efficiency loading for 300 W configuration Updated Capacitive Load section to use standard capacitor values Updated 5 VSB efficiency recommendations for Digital Office platforms Removed power-down warning from power supply timing diagram Marked sections with labels to indicate REQUIRED, RECOMMENDED, or OPTIONAL items 	January 2006
1.0	<ul style="list-style-type: none"> Added 12V2 Current for Processor Configurations table Added revision numbers to form factor specific chapters Changed Input Line Current Harmonic Content to OPTIONAL to better reflect geographical requirements 	June 2006
1.1	<ul style="list-style-type: none"> Removed outdated ENERGY STAR* requirements and added some new ENERGY STAR information. Updated Typical Power Distribution tables for all power supply form factors and updated minimum loads. Updated cross regulation figures. Added Flex ATX power supply form factor. Updated capacitive loading table. Clarified over voltage and over current verbiage. Added Power-up Cross Loading Condition section. Other changes shown in red with change bars. 	March 2007
1.2	<ul style="list-style-type: none"> 3.3.1 and .3 Added max of 400 mV Ripple/Noise to PS_ON and PWR_OK signals 14.2 Figure 49 replaced to implement change in dimension C 3.3 Added Power-down timing to Figure 2 and Table 20 (T6 > 1 ms) 7.3 Clarified Class D requirements. Added additional references for EMC requirements by country 3.5.9 Added Climate Savers Computing text Updated all Cross-regulation graphs 2.0 updated configuration charts Removed dates from reference documentation. Refer to latest version available Updated figure 58 	February 2008

§



1 Introduction

This document provides design suggestions for various power supply form factors. The power supplies are primarily intended for use with desktop system designs. It should not be inferred that all power supplies must conform exactly to the content of this document, though there are key parameters that define mechanical fit across a common set of platforms. Since power supply needs vary depending on system configuration, the design specifics described are not intended to support all possible systems.

1.1 Reference Documentation

The following documents are referenced in various sections of this design guide. For guidelines not specifically mentioned here, please reference the appropriate document.

Document	Document Number/Source or Password
European Association of Consumer Electronics Manufacturers (EACEM*) Hazardous Substance List / Certification	AB13-94-146
IEEE* Recommended Practice on Surge Voltages in Low-Voltage AC Circuits	ANSI* C62.41
IEEE Guide on Surge Testing for Equipment Connected to Low-Voltage AC Power Circuits	ANSI C62.45
Nordic national requirement in addition to EN 60950	EMKO-TSE (74-SEC) 207/94
American National Standard for Methods of Measurement of Radio-Noise Emissions from Low-Voltage Electrical and Electronic Equipment in the Range of 9 kHz to 40 GHz for EMI testing	ANSI C63.4
UL 60950-1 First Edition –CAN/CSA-C22.2 No. 60950-1-03 First Edition,	
IEC 60950-1: 2001 + Amendments and National Deviations,	
EN 60950-1: 2001 + Amendment A11:	
EU Low Voltage Directive (73/23/EEC) (CE Compliance)	
GB-4943 (China)	
CNS 14336: (Taiwan BSMI)	
FCC*, Class B, Part 15 (Radiated & Conducted Emissions)	
CISPR* 22 / EN55022, 5th Edition (Radiated & Conducted Emissions)	
EN55024 (ITE Specific Immunity)	
EN 61000-4-2 – Electrostatic Discharge	
EN 61000-4-3– Radiated RFI Immunity	
EN 61000-4-4– Electrical Fast Transients	
EN 61000-4-5 – Electrical Surge	



Document	Document Number/Source or Password
EN 61000-4-6 – RF Conducted	
EN 61000-4-8 – Power Frequency Magnetic Fields	
EN 61000-4-11 – Voltage Dips, Short Interrupts and Fluctuations	
EN61000-3-2 (Harmonics)	
EN61000-3-3 (Voltage Flicker)	
EU EMC Directive ((8/9/336/EEC) (CE Compliance)	

1.2 Terminology

Table 1 defines the acronyms, conventions, and terminology that are used throughout the design guide.

Table 1. Conventions and Terminology

Acronym, Convention/ Terminology	Definition
AWG	American Wire Gauge
BA	Declared sound power, LwAd. The declared sound power level shall be measured according to ISO* 7779 for the power supply and reported according to ISO 9296.
CFM	Cubic Feet per Minute (airflow).
Monotonically	A waveform changes from one level to another in a steady fashion, without oscillation.
MTBF	Mean time between failure.
Noise	The periodic or random signals over frequency band of 0 Hz to 20 MHz.
Overcurrent	A condition in which a supply attempts to provide more output current than the amount for which it is rated. This commonly occurs if there is a “short circuit” condition in the load attached to the supply.
PFC	Power Factor Corrected.
PWR_OK	PWR_OK is a “power good” signal used by the system power supply to indicate that the +5VDC, +3.3 VDC and +12VDC outputs are within the regulation thresholds of the power supply.
Ripple noise	The periodic or random signals over a frequency band of 0 Hz to 20 MHz.
Rise Time	Rise time is defined as the time it takes any output voltage to rise from 10% to 95% of its nominal voltage.
Surge	The condition where the AC line voltage rises above nominal voltage.
VSB or Standby Voltage	An output voltage that is present whenever AC power is applied to the AC inputs of the supply.

**Table 2. Support Terminology**

Category	Description
Optional	The status given to items within this design guide, which are not required to meet design guide, however, some system applications may optionally use these features. May be a required or recommended item in a future design guide.
Recommended	The status given to items within this design guide, which are not required to meet design guide, however, are required by many system applications. May be a required item in a future design guide.
Required	The status given to items within this design guide, which are required to meet design guide and a large majority of system applications.

§





2 Platform Configurations

2.1 Digital Home and Digital Office Platform Configurations - RECOMMENDED

Table 3 through Table 12 show power supply recommendations for various platform configurations. The configurations here and the recommended power supplies are suggestions. System designers should perform engineering analysis based on the specific system configuration to determine the appropriate power supply for their needs.

Table 3. Digital Office Platform Configurations for 2008

Line Item	Config 1	Config 2
Processor TDP	95 W	65 W
Chipset	Eaglelake-Q/ICH10DO	
Memory	DDR2, 4 GB or DDR3, 4 GB	DDR2, 2-4 GB or DDR3, 4 GB
Graphics	Integrated	
Audio	Intel® High Definition Audio	
LAN	Intel® 82567 Gigabit LAN	
Add-in cards	None	
Hard drive	2 SATA Drives	
Optical drive	SATA ODD	
USB devices	3 high power, 7 low power USB	
Fans	ATX thermal solution fan and chassis fan	
Power Supply Recommendation	ATX12V, SFX12V, TFX12V, CFX12V, LFX12V, Flex ATX 220 W	ATX12V, SFX12V, TFX12V, CFX12V, LFX12V, Flex ATX 180 W



Table 4. Digital Home Platform Configurations for 2008

Line Item	HEDT Config	Config 2	Config 3	Config 4
Processor TDP	130 W	95 W	65 W	
Chipset	Tylersburg/ICH9	Eaglelake-P/ICH10		Eaglelake-G/ICH10
Memory	DDR3, 6 DIMMs, up to 24 GB	DDR3, 4 GB	DDR2, 2 GB	
Graphics	2x300W graphics	75 W	50 W	Integrated
Audio	Intel® High Definition Audio 7.1			
LAN	Intel® 82567 Gigabit LAN			
Add-in cards	Wireless LAN, 1394, TV tuner			
Hard drive	2 SATA hard drives			
Optical drive	SATA Bluera y or HD DVD ODD			
USB devices	4 high power, 8 low power USB	3 high power, 7 low power USB		
Fans	ATX thermal solution fan and chassis fan			
Power Supply Recommendation	EPS12V ¹ ≥ 850 W	ATX12V 350 W	ATX12V, SFX12V, TFX12V, CFX12V, LFX12V, Flex ATX 220 W	ATX12V, SFX12V, TFX12V, CFX12V, LFX12V, Flex ATX 220 W

NOTES:

1. The EPS12V power supply design guide can be found at the SSI Forum website:
<http://ssiforum.oaktree.com/ViewUserDocuments.aspx>

Table 5. Digital Home Platform Configurations for 2007 - Lifestyle EPC Mainstream

Line Item	Description			
Processor TDP	65 W	105 W	65 W	105 W
Chipset	Intel® G35 chipset			
Memory	2 DDR3 DIMMs, 1066 MHz, 1 GB			
Graphics	Integrated		1 PCI Express* x16 add-in (75 W)	
Audio	Intel® High Definition Audio			
LAN	Intel® 82566 1 Gb LAN			
Add-in cards	Wireless LAN, 1394, TV tuner/capture			
Hard drive	1 SATA hard drive			
Optical drive	1 SATA optical drive			
USB devices	2 high power and 10 low power USB devices			
Fans	1 processor fan and 1 chassis fan			
Power Supply Recommendation	ATX12V, SFX12V, TFX12V, CFX12V, LFX12V, Flex ATX 270 W	ATX12V, SFX12V, TFX12V, CFX12V, LFX12V, Flex ATX 270 W	ATX12V, SFX12V, TFX12V, CFX12V 300 W	ATX12V 350 W

Table 6. Digital Home Platform Configurations for 2007 - CE EPC

Line Item	Description			
Processor TDP	65 W	95 W	65 W	95 W
Chipset	Intel® G35 chipset			
Memory	2 DDR3 DIMMs, 1066 MHz, 1 GB			
Graphics	Integrated		1 PCI Express* x16 add-in (75 W)	
Audio	Intel® High Definition Audio			
LAN	Intel® 82566 1 Gb LAN			
Add-in cards	Wireless LAN, 1394, TV tuner/capture			
Hard drive	1 SATA hard drive			
Optical drive	1 SATA optical drive			
USB devices	2 high power and 10 low power USB devices			
Fans	1 processor fan			
Power Supply Recommendation	ATX12V, SFX12V, TFX12V, CFX12V, LFX12V, Flex ATX 270 W	ATX12V, SFX12V, TFX12V, CFX12V, LFX12V, Flex ATX 270 W	ATX12V, SFX12V, TFX12V, CFX12V 300 W	ATX12V 350 W

Table 7. Digital Home Platform Configurations for 2007 - Lifestyle EPC Premium

Line Item	Description		
Processor TDP	65 W	105 W	95 W
Chipset	Intel® X38 chipset		
Memory	2 DDR3 DIMMs, 1066 MHz, 1 GB		
Graphics	Integrated		2 PCI Express* x16 add-in (150 W total W)
Audio	Intel® High Definition Audio		
LAN	Intel® 82566 1 Gb LAN		
Add-in cards	Wireless LAN, 1394, TV tuner/capture		
Hard drive	2 SATA hard drives		
Optical drive	1 SATA optical drive		
USB devices	2 high power and 10 low power USB devices		
Fans	1 processor fan and 1 chassis fan		
Power Supply Recommendation	ATX12V, SFX12V, TFX12V, CFX12V, LFX12V, Flex ATX 270 W	ATX12V, SFX12V, TFX12V, CFX12V, LFX12V, Flex ATX 270 W	ATX12V 400 W



Table 8. Digital Home Platform Configurations for 2007 - Extreme Gaming and Media

Line Item	Description
Processor TDP	130 W
Chipset	Intel® X38 chipset
Memory	4 DDR3 DIMMs, 1066 MHz, 4 GB
Graphics	1 PCI Express* x16 add-in (300 W total)
Audio	Intel® High Definition Audio
LAN	Intel® 82566 1 Gb LAN
Add-in cards	Wireless LAN, 1394, TV tuner/capture
Hard drive	4 SATA hard drives
Optical drive	1 SATA optical drive
USB devices	2 high power and 10 low power USB devices
Fans	1 processor fan and 1 chassis fan
Power Supply Recommendation	EPS12V ¹ ≥ 600 W

NOTES:

- The EPS12V power supply design guide can be found at the SSI Forum website:
<http://ssiforum.oaktree.com/ViewUserDocuments.aspx>

Table 9. Digital Office Platform Configurations for 2007 - Entry

Line Item	Description	
Processor TDP	65 W	95 W
Chipset	Intel® 946GZ chipset	
Memory	1 DDR2 DIMM, 667 MHz, 512 MB	
Graphics	Integrated	
Audio	Intel® High Definition Audio	
LAN	10/100M LAN	
Add-in cards	None	
Hard drive	1 SATA hard drive	
Optical drive	1 SATA optical drive	
USB devices	2 high power and 10 low power USB devices	
Fans	1 processor fan, 1 chassis fan	
Power Supply Recommendation	ATX12V, SFX12V, TFX12V, CFX12V, LFX12V, Flex ATX 180 W	ATX12V, SFX12V, TFX12V, CFX12V, LFX12V, Flex ATX 220 W

Table 10. Digital Office Platform Configurations for 2007 - Fundamental

Line Item	Description	
Processor TDP	65 W	95 W
Chipset	Intel® Q33 chipset	
Memory	2 DDR2 DIMMs, 800 MHz, 1 GB	
Graphics	Integrated	
Audio	Intel® High Definition Audio	
LAN	Intel® 82566 1 Gb LAN	
Add-in cards	None	
Hard drive	1 SATA hard drive	
Optical drive	1 SATA optical drive	
USB devices	2 high power and 10 low power USB devices	
Fans	1 processor fan, 1 chassis fan	
Power Supply Recommendation	SFX12V, TFX12V, CFX12V, LFX12V, Flex ATX 180 W	SFX12V, TFX12V, CFX12V, LFX12V, Flex ATX 220 W

Table 11. Digital Office Platform Configurations for 2007 - Professional

Line Item	Description	
Processor TDP	65 W	95 W
Chipset	Intel® Q35 chipset	
Memory	2 DDR2 DIMMs, 800 MHz, 1 GB	
Graphics	Integrated	
Audio	Intel® High Definition Audio	
LAN	Intel® 82566 1 Gb LAN	
Add-in cards	Wireless LAN	
Hard drive	1 SATA hard drive	
Optical drive	1 SATA optical drive	
USB devices	2 high power and 10 low power USB devices	
Fans	1 processor fan	
Power Supply Recommendation	LFX12V, Flex ATX 180 W	LFX12V, Flex ATX 220 W

Table 12. Digital Office Platform Configurations for 2007 - High Performance

Line Item	Description		
Processor TDP	65 W	95 W	105 W
Chipset	Intel® X38 chipset		
Memory	4 DDR3 DIMMs, 1066 MHz, 2GB		



Table 12. Digital Office Platform Configurations for 2007 - High Performance

Line Item	Description		
Graphics	Integrated		
Audio	Intel® High Definition Audio		
LAN	Intel® 82566 1 Gb LAN		
Add-in cards	Wireless LAN, Media Expansion Card		
Hard drive	2 SATA hard drive		
Optical drive	1 SATA optical drive		
USB devices	2 high power and 10 low power USB devices		
Fans	1 processor fan		
Power Supply Recommendation	LFX12V, Flex ATX 180 W	LFX12V, Flex ATX 220 W	LFX12V, Flex ATX 270 W

Table 13. 12V2 Current for Processor Configurations

Processor Configuration	Processor TDP	12V2 Current Recommendation	
		Continuous	Peak ¹
O4A	84 W	13 A	-
O4B	115 W	13 A	-
O5A	95 W	13 A	16.5 A
O5B	105 W ²	14 A	18 A
	130 W	16 A	19 A
O6	65 W	8 A	13 A

NOTES:

1. The power supply should be able to supply peak current for at least 10 ms.
2. The O5B processor configuration full TDP is 130 W. However, some processors that fall into this configuration will have lower TDP values such as 105 W.



3 Electrical

The following electrical requirements are required and must be met over the environmental ranges as defined in [Chapter 6](#) (unless otherwise noted).

3.1 AC Input - REQUIRED

[Table 14](#) lists AC input voltage and frequency requirements for continuous operation. The power supply shall be capable of supplying full-rated output power over two input voltage ranges rated 100-127 VAC and 200-240 VAC rms nominal. The correct input range for use in a given environment may be either switch-selectable or auto-ranging. The power supply shall automatically recover from AC power loss. The power supply must be able to start up under peak loading at 90 VAC.

Note: OPTIONAL - 115 VAC or 230 VAC only power supplies are an option for specific geographical or other requirements.

Table 14. AC Input Line Requirements

Parameter	Minimum	Nominal ¹	Maximum	Unit
V _{in} (115 VAC)	90	115	135	VAC _{rms}
V _{in} (230 VAC)	180	230	265	VAC _{rms}
V _{in} Frequency	47	-	63	Hz
I _{in} (115 VAC)	-	-	6	A _{rms}
I _{in} (230 VAC)	-	-	3	A _{rms}

NOTES:

1. Nominal voltages for test purposes are considered to be within ± 1.0 V of nominal.

3.1.1 Input Over Current Protection - REQUIRED

The power supply is required to incorporate primary fusing for input over current protection to prevent damage to the power supply and meet product safety requirements. Fuses should be slow-blow-type or equivalent to prevent nuisance trips.

3.1.2 Inrush Current - REQUIRED

Maximum inrush current from power-on (with power-on at any point on the AC sine) and including, but not limited to, three line cycles, shall be limited to a level below the surge rating of the AC switch if present, bridge rectifier, and fuse components. Repetitive ON/OFF cycling of the AC input voltage should not damage the power supply or cause the input fuse to blow.

3.1.3 Input Under Voltage - REQUIRED

The power supply is required to contain protection circuitry such that the application of an input voltage below the minimum specified in [Table 14](#), shall not cause damage to the power supply.



3.2 DC Output - REQUIRED

3.2.1 DC Voltage Regulation

The DC output voltages are required to remain within the regulation ranges shown in [Table 15](#), when measured at the load end of the output connectors under all line, load, and environmental conditions specified in [Chapter 6](#).

Table 15. DC Output Voltage Regulation

Output	Range	Min	Nom	Max	Unit
+12V1DC ¹	±5%	+11.40	+12.00	+12.60	V
+12V2DC ²	±5%	+11.40	+12.00	+12.60	V
+5VDC	±5%	+4.75	+5.00	+5.25	V
+3.3VDC ³	±5%	+3.14	+3.30	+3.47	V
-12VDC	±10%	-10.80	-12.00	-13.20	V
+5VSB	±5%	+4.75	+5.00	+5.25	V

NOTES:

- At +12V1DC peak loading, regulation at the +12V1DC and +12V2DC outputs can go to ±10%.
- At +12V2DC peak loading, regulation at the +12V1DC and +12V2DC outputs can go to ±10%.
- Voltage tolerance is required at main connector and SATA connector (if used).

3.2.2 Output Transient Response - REQUIRED

[Table 16](#) summarizes the expected output transient step sizes for each output. The transient load slew rate is = 1.0 A/μs.

Table 16. DC Output Transient Step Sizes¹

Output	Maximum Step Size (% of rated output amps)	Maximum Step Size (A)
+12V1DC	40%	-
+12V2DC	60%	-
+5 VDC	30%	-
+3.3 VDC	30%	-
-12 VDC	-	0.1
+5 VSB	-	0.5

NOTES:

- For example, for a rated +5 VDC output of 14 A, the transient step would be 30% × 14 A = 4.2 A.

Output voltages should remain within the regulation limits of [Table 15](#), for instantaneous changes in load as specified in [Table 16](#) and for the following conditions:

- Simultaneous load steps on the +12 VDC, +5 VDC, and +3.3 VDC outputs (all steps occurring in the same direction)
- Load-changing repetition rate of 50 Hz to 10 kHz
- AC input range per Section 2.1 and Capacitive loading per [Table 19](#).



3.2.3 Remote Sensing - REQUIRED

The +3.3 VDC output should have provisions for remote sensing to compensate for excessive cable drops. The default sense should be connected to pin 13 of the main power connector (Figure 7). The power supply should draw no more than 10 mA through the remote sense line to keep DC offset voltages to a minimum.

3.2.4 Other Low Power System Requirements - RECOMMENDED

To help meet the Blue Angel* system requirements, RAL-UZ 78, US Presidential executive order 13221, ENERGY STAR* requirements, and other low Power system demands, It is recommended that the +5 VSB standby supply efficiency should be as high as possible. Standby efficiency is measured with the main outputs off (PS_ON# high state). Standby efficiency should be as shown in Table 17.

Table 17. Recommended 5 VSB Efficiency

Load	Efficiency
100 mA	≥ 50%
250 mA	≥ 60%
≥ 1 A	≥ 70%

3.2.5 Output Ripple Noise - REQUIRED

The output ripple noise requirements listed in Table 18 should be met throughout the load ranges specified for the appropriate form factor and under all input voltage conditions as specified in Table 14.

Ripple and noise are defined as periodic or random signals over a frequency band of 10 Hz to 20 MHz. Measurements shall be made with an oscilloscope with 20 MHz of bandwidth. Outputs should be bypassed at the connector with a 0.1 μF ceramic disk capacitor and a 10 μF electrolytic capacitor to simulate system loading. See Figure 1 for the differential noise measurement setup.

Table 18. DC Output Noise/Ripple

Output	Maximum Ripple and Noise (mV p-p)
+12 V1DC	120
+12 V2DC	120
+5 VDC	50
+3.3 VDC	50
-12 VDC	120
+5 VSB	50

Figure 1. Differential Noise Test Setup

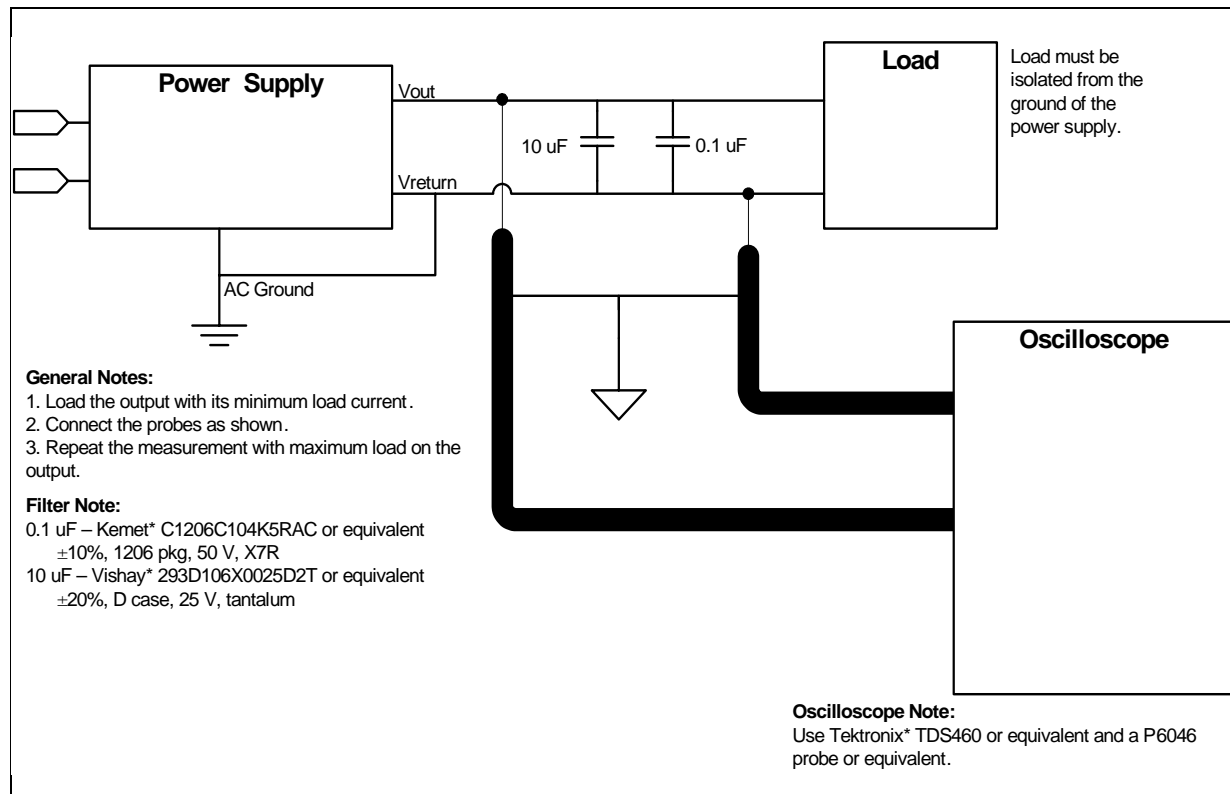

3.2.6 Capacitive Load - REQUIRED

The power supply should be able to power up and operate with the regulation limits defined in [Table 15](#), with the following capacitances simultaneously present on the DC outputs.

Table 19. Output Capacitive Loads

Output	Capacitive Load (µF)
+12 V1DC	10,000
+12 V2DC	10,000
+5 VDC	10,000
+3.3 VDC	10,000
-12 VDC	330
+5 VSB	10,000

3.2.7 Closed Loop Stability - REQUIRED

The power supply shall be unconditionally stable under all line/load/transient load conditions including capacitive loads specified in [Section 3.2.6](#). A minimum of 45 degrees phase margin and 10 dB gain margin is recommended at both the maximum and minimum loads.

3.2.8 +5 VDC / +3.3 VDC Power Sequencing - REQUIRED

The +12V1 DC / +12V2 DC and +5 VDC output levels must be equal to or greater than the +3.3 VDC output at all times during power-up and normal operation. The time between any output of +12V1 DC / +12V2 DC and +5 VDC reaching its minimum in-regulation level and +3.3 VDC reaching its minimum in-regulation level must be ≤ 20 ms.

3.2.9 Voltage Hold-up Time - REQUIRED

The power supply should maintain output regulations per [Table 15](#) despite a loss of input power at the low-end nominal range-115 VAC / 47 Hz or 230 VAC / 47 Hz - at maximum continuous output load as applicable for a minimum of 16 ms.

3.3 Timing, Housekeeping and Control - REQUIRED

Figure 2. Power Supply Timing

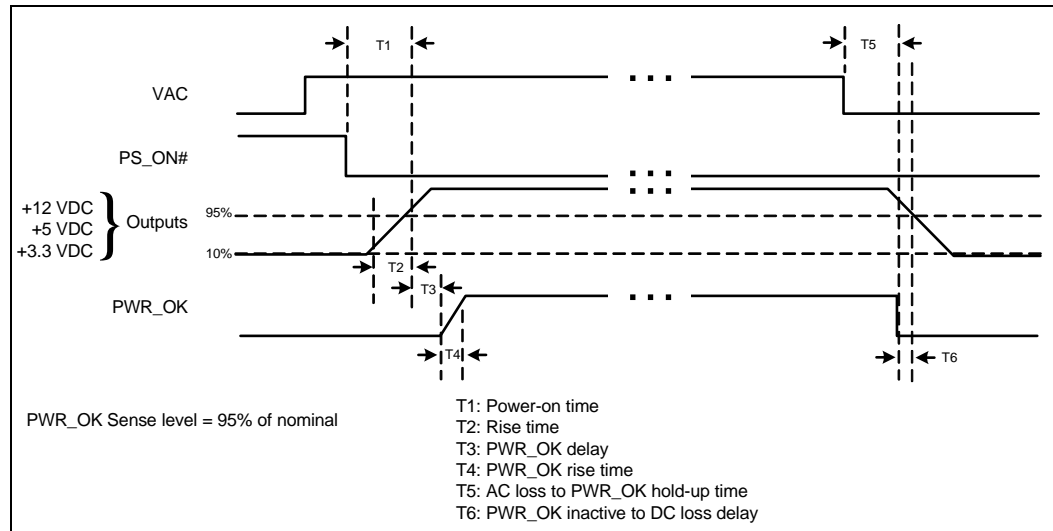

3.3.1 PWR_OK

PWR_OK is a “power good” signal. This signal should be asserted high by the power supply to indicate that the +12 VDC, +5 VDC, and +3.3 VDC outputs are within the regulation thresholds listed in [Table 15](#) and that sufficient mains energy is stored by the converter to guarantee continuous power operation within specification for at least the duration specified in [Section 3.2.9](#). Conversely, PWR_OK should be de-asserted to a low state when any of the +12 VDC, +5 VDC, or +3.3 VDC output voltages falls below its under voltage threshold, or when mains power has been removed for a time sufficiently long such that power supply operation cannot be guaranteed. The electrical and timing characteristics of the PWR_OK signal are given in [Table 21](#) and in [Figure 2](#).

Table 20. PWR_OK Signal Timing

Parameter	Description	Value
T1	Power-on time	< 500 ms
T2	Rise time	0.2 - 20 ms
T3	PWR_OK delay	100 - 500 ms
T4	PWR_OK rise time	< 10 ms
T5	AC loss to PWR_OK hold-up time	> 16 ms
T6	PWR_OK inactive to DC loss delay	>1 ms

Table 21. PWR_OK Signal Characteristics

Signal type	+5 V TTL compatible
Logic level low	< 0.4 V while sinking 4 mA
Logic level high	Between 2.4 V and 5 V output while sourcing 200 μ A
High state output impedance	1 k Ω from output to common
Max Ripple/Noise	400 mV pk-pk

3.3.2 Power-up Cross Loading Condition

In the time frame between PS_ON# assertion and PWR_OK assertion (T1+T3), the power supply may be subjected to a cross load condition on the 12 V and 3.3/5 V rails. The power supply should be able to successfully power-up and assert PWR_OK when 12 V (or combination of 12V1 and 12V2) is loaded to ≤ 0.1 A and 3.3 V and/or 5 V are loaded to 0-5 A.

3.3.3 PS_ON#

PS_ON# is an active-low, TTL-compatible signal that allows a motherboard to remotely control the power supply in conjunction with features such as soft on/off, Wake on LAN*, or wake-on-modem. When PS_ON# is pulled to TTL low, the power supply should turn on the four main DC output rails: +12 VDC, +5 VDC, +3.3 VDC, and -12 VDC. When PS_ON# is pulled to TTL high or open-circuited, the DC output rails should not deliver current and should be held at zero potential with respect to ground. PS_ON# has no effect on the +5 VSB output, which is always enabled whenever the AC power is present. [Table 22](#) lists PS_ON# signal characteristics.

The power supply shall provide an internal pull-up to TTL high. The power supply shall also provide de-bounce circuitry on PS_ON# to prevent it from oscillating on/off at startup when activated by a mechanical switch. The DC output enable circuitry must be SELV-compliant.

The power supply shall not latch into a shutdown state when PS_ON# is driven active by pulses between 10 ms to 100 ms during the decay of the power rails.



Table 22. PS_ON# Signal Characteristics

Parameter	Minimum	Maximum
V _{IL}	0	0.8 V
I _{IL} (V _{IN} = 0.4 V)	-	-1.6 mA ¹
V _{IH} (I _{IN} = - 200 uA)	2.0 V	-
V _{IH} open circuit	-	5.25 V
Ripple / Noise		400 mV pk-pk

NOTES:

1. Negative current indicates that the current is flowing from the power supply to the motherboard.

Figure 3. PS_ON# Signal Characteristics

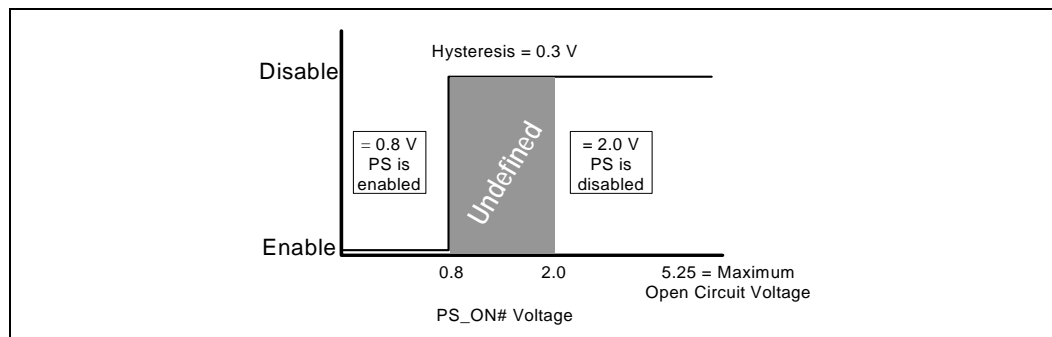

3.3.4 +5 VSB

+5 VSB is a standby supply output that is active whenever the AC power is present. This output provides a power source for circuits that must remain operational when the five main DC output rails are in a disabled state. Example uses include soft power control, Wake on LAN, wake-on-modem, intrusion detection, or suspend state activities.

The power supply must be able to provide the required power during a “wake up” event. If an external USB device generates the event, there may be peak currents as high as 2.5 A., lasting no more than 500 ms.

Over current protection is required on the +5 VSB output regardless of the output current rating. This ensures the power supply will not be damaged if external circuits draw more current than the supply can provide.

3.3.5 Power-on Time

The power-on time is defined as the time from when PS_ON# is pulled low to when the +12 VDC, +5 VDC, and +3.3 VDC outputs are within the regulation ranges specified in [Table 15](#). The power-on time shall be less than 500 ms (T₁ < 500 ms).

+5 VSB shall have a power-on time of two seconds maximum after application of valid AC voltages.



3.3.6 Rise Time

The output voltages shall rise from 10% of nominal to within the regulation ranges specified in Table 15 within 0.2 ms to 20 ms ($0.2\text{ ms} \leq T2 \leq 20\text{ ms}$).

There must be a smooth and continuous ramp of each DC output voltage from 10% to 90% of its final set point within the regulation band, while loaded as specified.

The smooth turn-on requires that, during the 10% to 90% portion of the rise time, the slope of the turn-on waveform must be positive and have a value of between 0 V/ms and $[V_{out, nominal} / 0.1]$ V/ms. Also, for any 5 ms segment of the 10% to 90% rise time waveform, a straight line drawn between the end points of the waveform segment must have a slope $\geq [V_{out, nominal} / 20]$ V/ms.

3.3.7 Overshoot at Turn-on / Turn-off

The output voltage overshoot upon the application or removal of the input voltage, or the assertion/de-assertion of PS_ON#, under the conditions specified in Table 15, shall be less than 10% above the nominal voltage. No voltage of opposite polarity shall be present on any output during turn-on or turn-off.

3.4 Reset after Shutdown

If the power supply latches into a shutdown state because of a fault condition on its outputs, the power supply shall return to normal operation only after the fault has been removed and the PS_ON# has been cycled OFF/ON with a minimum OFF time of one second.

3.4.1 +5 VSB at Power-down

After AC power is removed, the +5 VSB standby voltage output should remain at its steady state value for the minimum hold-up time specified in Section 3.2.9 until the output begins to decrease in voltage. The decrease shall be monotonic in nature, dropping to 0.0 V. There shall be no other disturbances of this voltage at or following removal of AC power.

3.5 Output Protection - REQUIRED

3.5.1 Over Voltage Protection

The over voltage sense circuitry and reference shall reside in packages that are separate and distinct from the regulator control circuitry and reference. No single point fault shall be able to cause a sustained over voltage condition on any or all outputs. The supply shall provide latch-mode over voltage protection as defined in Table 23.

Table 23. Over Voltage Protection

Output	Minimum (V)	Nominal (V)	Maximum (V)
+12 VDC (or 12V1DC & 12V2DC)	13.4	15.0	15.6
+5 VDC	5.74	6.3	7.0
+3.3 VDC	3.76	4.2	4.3
5 VSB ¹	5.74	6.3	7.0

**NOTES:**

1. Over voltage protection is RECOMMENDED but not REQUIRED for this output. While over voltage protection is not required for this output, system damage may occur in the case of an over voltage event.

3.5.2 Short Circuit Protection

An output short circuit is defined as any output impedance of less than 0.1 ohms. The power supply shall shut down and latch off for shorting the +3.3 VDC, +5 VDC, or +12 VDC rails to return or any other rail. The +12V1 DC and 12V2 DC should have separate short circuit and over current protection. Shorts between main output rails and +5 VSB shall not cause any damage to the power supply. The power supply shall either shut down and latch off or fold back for shorting the negative rails. +5 VSB must be capable of being shorted indefinitely. When the short is removed, it is recommended that the power supply shall recover automatically or by cycling PS_ON#. Optionally, the power supply may latch off when a +5 VSB short circuit event occurs. The power supply shall be capable of withstanding a continuous short circuit to the output without damage or overstress to the unit (for example, to components, PCB traces, and connectors) under the input conditions specified in [Table 14](#).

3.5.3 No-load Situation

No damage or hazardous condition should occur with all the DC output connectors disconnected from the load. The power supply may latch into the shutdown state.

3.5.4 Over Current Protection

Current protection should be designed to limit the current to operate within safe operating conditions.

Over current protection schemes where only the voltage output that experiences the over current event is shut off may be adequate to maintain safe operation of the power supply and the system; however, damage to the motherboard or other system components may occur. The recommended over current protection scheme is for the power supply to latch into the shutdown state.

3.5.5 Over Temperature Protection

As an option, the power supply may include an over-temperature protection sensor, which can trip and shut down the power supply at a preset temperature point. Such an overheated condition is typically the result of internal current overloading or a cooling fan failure. If the protection circuit is non-latching, then it should have hysteresis built in to avoid intermittent tripping.

3.5.6 Output Bypass

The output return may be connected to the power supply chassis, and will be connected to the system chassis by the system components.

3.5.7 Separate Current Limit for 12V2 - RECOMMENDED

The 12 V rail on the 2x2 power connector should be a separate current limited output to meet the requirements of UL and EN 60950.

3.5.8 Overall Power Supply Efficiency and ENERGY STAR

The efficiency of the power supply should be tested at nominal input voltage of 115 VAC input and 230 VAC input, under the load conditions defined in the form factor specific sections, and under the temperature and operating conditions defined in Chapter 6. The loading condition for testing efficiency shown in the form factor specific guidelines sections represent fully loaded systems, typical (50%) loaded systems, and light (20%) loaded systems. Refer to Chapter 10 through Chapter 15 for the efficiency loading for each power supply form factor.

Table 24. Efficiency Versus Load

Loading	Full Load	Typical Load	Light Load	PFC
REQUIRED Minimum Efficiency	70%	72%	65%	-
RECOMMENDED Minimum Efficiency	80%	80%	80%	≥0.9

The RECOMMENDED minimum efficiency levels shown in Table 24 are required for ENERGY STAR system compliance based the version 4.0 specification.

The ENERGY STAR computer specification requires at least 80% efficiency at 20%, 50% and 100% of the rated output capacity. This effectively provides a window of high efficiency that extends from 20% to 100% of the rated capacity of the power supply. Generally the efficiency of the power supply drops off significantly as the load falls below 20%. Because the power supply is one of the largest contributors to power loss in the system, it is important to maximize the efficiency in order to comply with the power targets for the various system categories. Below are two case examples for the desktop category B system to illustrate this concept. For these two cases, assume the efficiency curve in terms of percentage of the output is equivalent. This curve is shown in Figure 4.

Figure 4. PSU Efficiency as Percentage of Output

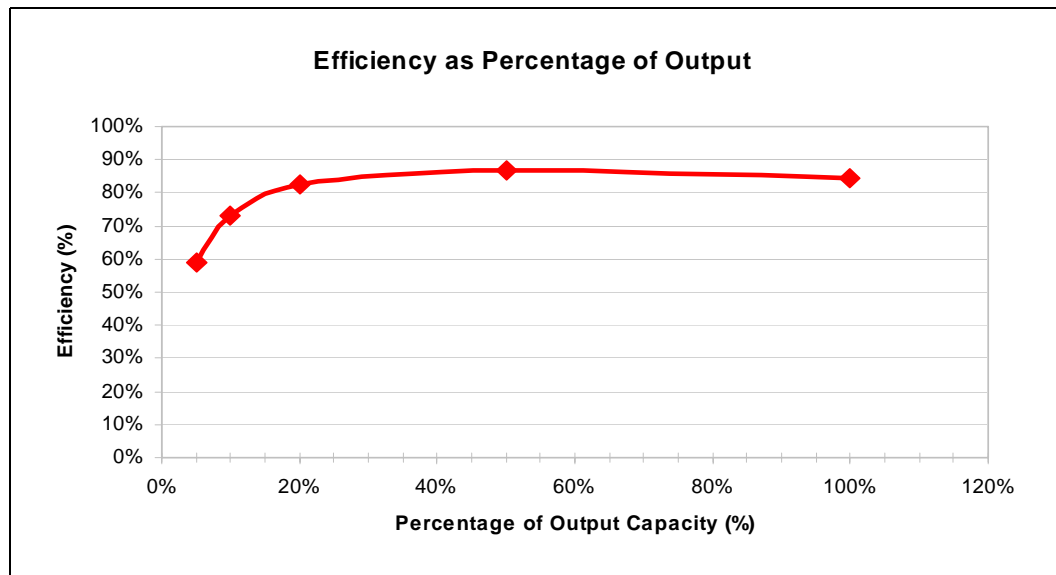

NOTES:

1. Graph is an estimated representation for illustrative purposes only.
2. This is not a recommended PSU efficiency curve. It is just included here as an example for the discussion of properly sizing the PSU for power savings.



CASE 1

For Case 1, suppose the system we are trying to configure to meet the desktop category B has a 450 W internal power supply. The category B idle power specification is 65 W AC wall power. The AC wall power is calculated or derived as shown in the following equation:

$$AC(W) = \frac{DC(W)}{\eta_{PSU}}$$

In order to minimize the AC wall power, we need to maximize the power supply efficiency. As can be seen from Figure 5, for a 450 W power supply, the efficiency is low when the system is at 65 W AC wall power. Because the category B system at idle is on the part of the power supply efficiency curve where the efficiency is low, the remaining power budget for the other system components is much less than if the power supply efficiency was higher.

Figure 5. PSU Efficiency per Power for 450 W PSU

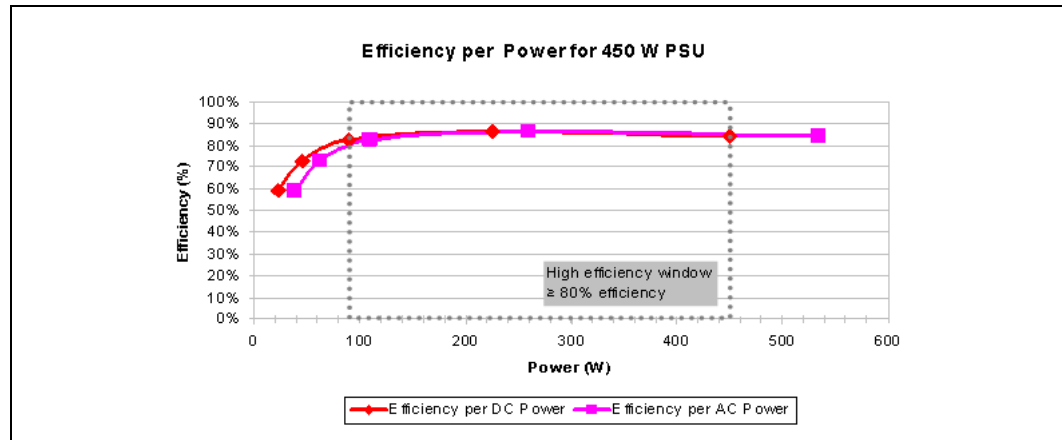

NOTE: Graph is an estimated representation for illustrative purposes only.

CASE 2

For Case 2, assume the system we are trying to configure for category B has a 250 W power supply. In this case, Figure 6 shows that for an idle state of 65 W AC wall power, the system is within the high efficiency window of the power supply.

Since the system is operating within the high efficiency window of the power supply when in the idle state, the power supply losses are minimized which allows additional budget for other system components.

Figure 6. PSU Efficiency per Power for 250 W PSU

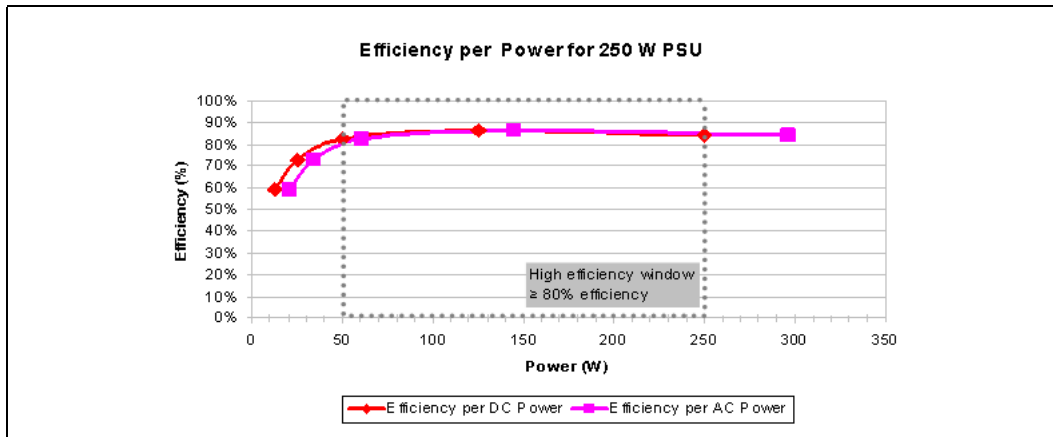

NOTE: Graph is an estimated representation for illustrative purposes only.

The examples in Case 1 and Case 2 above show that building the system with a power supply that is the proper size will maximize the power supply efficiency and allow the most flexibility for selecting other components in the system.

In order to stay within the $\geq 80\%$ efficiency window generally, the power supply sizes for each of the desktop system categories are shown in Table 25.

Table 25. Power Supply Sizes for ENERGY STAR Desktop System Categories

System Category	AC Wall Power - System Idle	Maximum Power Supply Size ¹
A	50 W	≤ 200 W
B	65 W	≤ 260 W
C	95 W	≤ 380 W

NOTES:

1. The power supply sizes shown in this table represent the maximum size in order to stay within the $\geq 80\%$ efficiency window. It is important, however, to ensure that the power supply also has sufficient capacity to handle the active or heavy workloads that the system may be subjected to. Larger power supplies are sometimes needed to allow for future system upgrades though a trade-off for efficiency in the idle state may be necessary.

3.5.9 Overall Power Supply Efficiency and Climate Savers

The Climate Savers Computing Initiative operates in a manner similar to the U.S. Government’s Energy Star program. It is intended to promote both the deployment of existing technologies and investment in new energy-efficiency technologies. The new Energy Star standard for desktops, laptops, and workstations, which takes effect in July 2007, requires power supplies to be at least 80% efficient for most of their load range. In addition, it puts limits on the energy used by devices when inactive and requires systems to be shipped with power management features enabled. The Challenge starts with the 2007 Energy Star requirements for desktops, laptops, and workstations (including monitors), and gradually increases the efficiency requirements over the next 4 years, as follows:



1. From July 2007 through June 2008, PCs must meet the Energy Star requirements. This means 80% minimum efficiency for the power supply unit (PSU) at 20%, 50%, and 100% of rated output, a power factor of at least 0.9 at 100% of rated output, and meeting the maximum power requirements in standby, sleep, and idle modes.
2. From July 2008 through June 2009 the standard increases to 85% minimum efficiency for the PSU at 50% of rated output (and 82% minimum efficiency at 20% and 100% of rated output).
3. From July 2009 through June 2010, the standard increases to 88% minimum efficiency for the PSU at 50% of rated output (and 85% minimum efficiency at 20% and 100% of rated output).
4. From July 2010 through June 2011, the standard increases to 90% minimum efficiency for the PSU at 50% of rated output (and 87% minimum efficiency at 20% and 100% of rated output).

For more information on the Climate Savers Computing Initiative, visit their website at www.climatesaverscomputing.org.

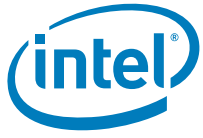



4 Mechanical

This section contains mechanical guidelines that apply to desktop power supplies regardless of form factor. For form factor specific design guides refer to [Chapter 10](#) through [Chapter 14](#).

4.1 Labeling and Marking - RECOMMENDED

The following is a non-inclusive list of suggested markings for each power supply unit. Product regulation stipulations for sale into various geographies may impose additional labeling requirements.

Manufacturer information: manufacturer's name, part number and lot date code, etc., in human-readable text and/or bar code formats

Nominal AC input operating voltages (100-127 VAC and 200-240 VAC) and current rating certified by all applicable safety agencies

DC output voltages and current ratings

Access warning text ("Do not remove this cover. Trained service personnel only. No user serviceable components inside.") must be in English, German, Spanish, French, Chinese, and Japanese with universal warning markings.

4.2 Connectors - REQUIRED

4.2.1 AC Connector

The AC input receptacle should be an IEC 320 type or equivalent. In lieu of a dedicated switch, the IEC 320 receptacle may be considered the mains disconnect.

4.2.2 DC Connectors

[Figure 7](#) shows pin outs and profiles for typical power supply DC harness connectors. The power supply requires an additional two-pin, power connector.

UL Listed or recognized component appliance wiring material rated min 85 °C, 300 VDC shall be used for all output wiring.

There are no specific requirements for output wire harness lengths, as these are largely a function of the intended end-use chassis, motherboard, and peripherals. Ideally, wires should be short to minimize electrical/airflow impedance and simplify manufacturing, yet they should be long enough to make all necessary connections without any wire tension (which can cause disconnections during shipping and handling). Recommended minimum harness lengths for general-use power supplies is 150 mm for all wire harnesses. Measurements are made from the exit port of the power supply case to the wire side of the first connector on the harness.

Figure 7. Connectors (Pin-side view, not to scale)

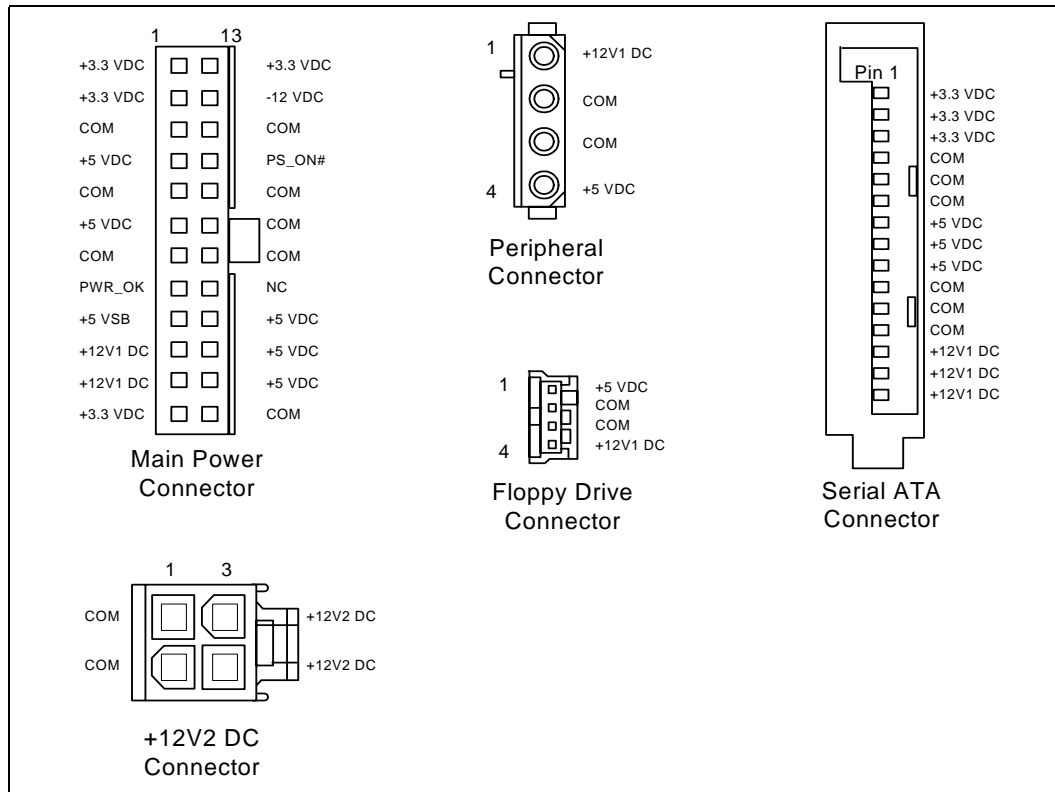

4.2.2.1 Main Power Connector

Connector: Molex* Housing: 24 Pin Molex Mini-Fit Jr. PN# 39-01-2240 or equivalent.

Contact: Molex 44476-1112 (HCS) or equivalent (Mating motherboard connector is Molex 44206-0007 or equivalent).

18 AWG is suggested for all wires except for the +3.3 V supply and sense return wires combined into pin 13 (22 AWG).

Table 26. Main Power Connector Pin-out

Pin	Signal	Color	Pin	Signal	Color
1	+3.3 VDC	Orange	13 [13]	+3.3 VDC [+3.3 V default sense]	Orange [Brown]
2	+3.3 VDC	Orange	14	-12 VDC	Blue
3	COM	Black	15	COM	Black
4	+5 VDC	Red	16	PS_ON#	Green
5	COM	Black	17	COM	Black
6	+5 VDC	Red	18	COM	Black
7	COM	Black	19	COM	Black

Table 26. Main Power Connector Pin-out

Pin	Signal	Color	Pin	Signal	Color
8	PWR_OK	Gray	20	Reserved	NC
9	+5 VSB	Purple	21	+5 VDC	Red
10	+12 V1DC	Yellow	22	+5 VDC	Red
11	+12 V1DC	Yellow	23	+5 VDC	Red
12	+3.3 VDC	Orange	24	COM	Black

4.2.2.2 Peripheral Connectors

Connector: AMP* 1-480424-0 or Molex* 15-24-4048 or equivalent.

Contacts: AMP 61314-1 or equivalent.

Table 27. Peripheral Connector Pin-out

Pin	Signal	Color ¹
1	+12 V1DC	Yellow
2	COM	Black
3	COM	Black
4	+5 VDC	Red

NOTES:

1. 18 AWG wire.

4.2.2.3 Floppy Drive Connector

Connector: AMP* 171822-4 or equivalent.

Table 28. Floppy Connector Pin-out

Pin	Signal	Color ¹
1	+5 VDC	Red
2	COM	Black
3	COM	Black
4	+12 V1DC	Yellow

NOTES:

1. 20 AWG wire.

4.2.2.4 +12 V Power Connector

Connector: Molex* 0039012040 or equivalent.

Contact: Molex 44476-1112 (HCS) or equivalent (Mating motherboard connector is Molex 39-29-9042 or equivalent).

Table 29. +12 V Power Connector Pin-out

Pin	Signal	Color ¹	Pin	Signal	Color ¹
1	COM	Black	3	+12 V2DC	Yellow
2	COM	Black	4	+12 V2DC	Yellow

NOTES:

1. 18 AWG wire.

4.2.2.5 Serial ATA* Power Connectors

This is a required connector for systems with Serial ATA devices.

The detailed requirements for the Serial ATA Power Connector can be found in the “Serial ATA: High Speed Serialized AT Attachment” specification, Section 6.3 “Cables and connector specification”.

<http://www.serialata.org/>

Note:

Connector pin numbers and wire numbers are not 1:1. Carefully check to confirm the correct arrangement.

Assembly: Molex* 88751 or equivalent.

Table 30. Serial ATA* Power Connector Pin-out

Wire	Signal	Color ¹
5	+3.3 VDC	Orange
4	COM	Black
3	+5 VDC	Red
2	COM	Black
1	+12 V1DC	Yellow

NOTES:

1. 18 AWG wire.

Figure 8. Serial ATA* Power Connector

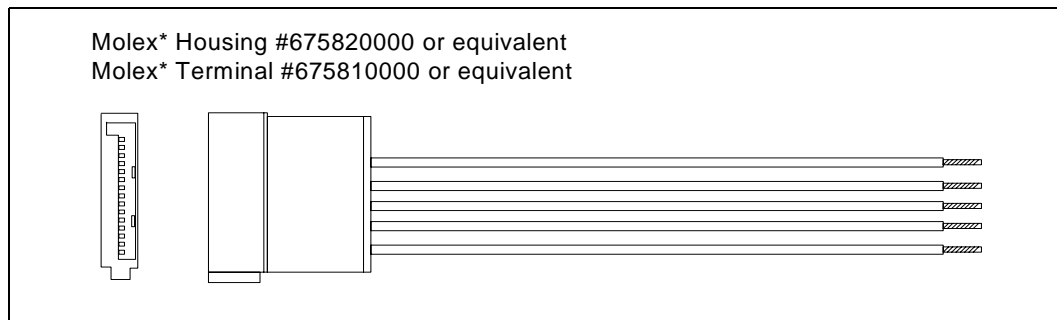

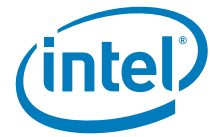

4.3 Airflow and Fans - RECOMMENDED

The designer's choice of a power supply cooling solution depends in part on the targeted end-use system application(s). At a minimum, the power supply design must ensure its own reliable and safe operation.

4.3.1 Fan Location and Direction

In general, exhausting air from the system chassis enclosure via a power supply fan at the rear panel is the preferred, most common, and most widely applicable system-level airflow solution. However, some system/chassis designers may choose to use other configurations to meet specific system cooling requirements.

4.3.2 Fan Size and Speed

A thermally sensitive fan speed control circuit is recommended to balance system-level thermal and acoustic performance. The circuit typically senses the temperature of the secondary heatsink and/or incoming ambient air and adjusts the fan speed as necessary to keep power supply and system component temperatures within specification. Both the power supply and system designers should be aware of the dependencies of the power supply and system temperatures on the control circuit response curve and fan size and should specify them carefully.

The power supply fan should be turned off when PS_ON# is de-asserted (high). In this state, any remaining active power supply circuitry must rely only on passive convection for cooling.



4.3.3 Venting

In general, more venting in a power supply case yields reduced airflow impedance and improved cooling performance. Intake and exhaust vents should be large, open, and unobstructed as possible so as not to impede airflow or generate excessive acoustic noise. In particular, avoid placing objects within 0.5 inches of the intake or exhaust of the fan itself. A flush-mount wire fan grill can be used instead of a stamped metal vent for improved airflow and reduced acoustic noise.

The limitations to the venting guidelines above are:

- Openings must be sufficiently designed to meet the safety requirements described in [Chapter 8](#).
- Larger openings yield decreased EMI-shielding performance (see [Chapter 7](#)).
- Venting in inappropriate locations can detrimentally allow airflow to bypass those areas where it is needed.

§



5 Acoustics

5.1 Acoustics - RECOMMENDED

It is recommended that the power supply be designed with an appropriate fan, internal impedance, and fan speed control circuitry capable of meeting the acoustic targets listed in [Table 31](#).

The power supply assembly shall not produce a prominent discrete tone determined according to ISO 7779, Annex D.

Sound power determination is to be performed at 43 C, at 50% of the maximum rated load, at sea level. This test point is chosen to represent the environment seen inside a typical system at the idle acoustic test condition, with the 43 C being derived from the standard ambient assumption of 23 C, with 20 C added for the temperature rise within the system (what is typically seen by the inlet fan). The declared sound power shall be measured according to ISO 7779 and reported according to ISO 9296.

Table 31. Recommended Power Supply Acoustic Targets

	Idle (BA)	Typical (50% load) (BA)	Maximum (BA)
Minimum	3.5	4.0	5.0
Target	3.0	3.8	4.5

§

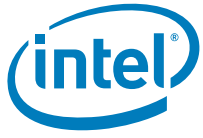



6 Environmental

The following subsections define environmental specifications and test parameters, based on the typical conditions to which a power supply may be subjected during operation or shipment.

6.1 Temperature - RECOMMENDED

- Operating ambient +10 °C to +50 °C (At full load, with a maximum temperature rate of change of 5 °C/10 minutes, but no more than 10 °C/hr.)
- Non-operating ambient -40 °C to +70 °C (Maximum temperature rate of change of 20 °C/hr.)

6.1.1 Thermal Shock (Shipping)

- Non-operating -40 °C to +70 °C
- $15\text{ °C/min} \leq dT/dt \leq 30\text{ °C/min}$
- Tested for 50 cycles; Duration of exposure to temperature extremes for each half cycle shall be 30 minutes.

6.2 Humidity - RECOMMENDED

- Operating To 85% relative humidity (non-condensing)
- Non-operating To 95% relative humidity (non-condensing)
- Note: 95% relative humidity is achieved with a dry bulb temperature of 55 °C and a wet bulb temperature of 54 °C.

6.3 Altitude - RECOMMENDED

- Operating To 10,000 ft
- Non-operating To 50,000 ft

6.4 Mechanical Shock - RECOMMENDED

- Non-operating 50 g, trapezoidal input; velocity change ≥ 170 in/s
- Three drops on each of six faces are applied to each sample.

6.5 Random Vibration - RECOMMENDED

- Non-operating 0.01 g²/Hz at 5 Hz, sloping to 0.02 g²/Hz at 20 Hz, and maintaining 0.02 g²/Hz from 20 Hz to 500 Hz. The area under the PSD curve is 3.13 gRMS. The duration shall be 10 minutes per axis for all three axes on all samples.

§





7 Electromagnetic Compatibility

The following subsections outline applicable product regulatory requirements for the power supplies. Additional requirements may apply dependent upon the design, product end use, target geography, and other variables.

7.1 Emissions - REQUIRED

The power supply shall comply with FCC Part 15, EN55022 and CISPR 22, 5th ed., meeting Class B for both conducted and radiated emissions with a 4 dB margin. Tests shall be conducted using a shielded DC output cable to a shielded load. The load shall be adjusted as follows for three tests: No load on each output; 50% load on each output; 100% load on each output. Tests will be performed at 100 VAC 50Hz, 120 VAC 60 Hz, and 230 VAC 50 Hz power. Additionally, for FCC certification purposes, the power supply shall be tested using the methods in 47 CFR 15.32(b) and authorized under the Declaration of Conformity process as defined in 47 CFR 2.906 using the process in 47 CFR 2.1071 through 47 CFR 2.1077.

7.2 Immunity - REQUIRED

The power supply shall comply with EN 55024 and CISPR 24 prior to sale in the EU (European Union), Korea, and possibly other geographies.

7.3 Input Line Current Harmonic Content - OPTIONAL

Class D harmonic limits will be determined at the time of measurement based on the actual power draw from the mains.

Table 32 is a partial list of countries and their current EMC requirements. Additional requirements may apply dependent upon the design, product end use, target geography, and other variables.

Table 32. EMC Requirements by Country

Country	Requirements Document
EU (European Union)	EN61000-3-2
Japan	JEIDA MITI
China	CCC & GB 17625.1
Russia	GOST R 51317.3.2

7.4 Magnetic Leakage Fields - REQUIRED

A PFC choke magnetic leakage field should not cause any interference with a high-resolution computer monitor placed next to or on top of the end-use chassis.



7.5 Voltage Fluctuations and Flicker - REQUIRED

The power supply shall meet the specified limits of EN61000-3-3 (IEC 61000-3-3) and amendment A1 to EN 61000-3-3 (IEC 61000-3-3/A1) for voltage fluctuations and flicker for equipment drawing not more than 16AAC, connected to low voltage distribution systems.

§



8 Safety

The following subsections outline sample product regulations requirements for a typical power supply. Actual requirements will depend on the design, product end use, target geography, and other variables. Consult your company's Product Safety and Regulations department or an accredited third party certification agency for more details.

8.1 North America - REQUIRED

The power supply must be certified by an NRTL (Nationally Recognized Testing Laboratory) for use in the USA and Canada under the following conditions:

- The power supply UL report "Conditions of Acceptability" shall meet in the intended application of the power supply in the end product.
- The supply must be recognized for use in Information Technology Equipment including Electrical Business Equipment per UL 60950-1 First Edition. The certification must include external enclosure testing for the AC receptacle side of the power supply (see Appendices A, B, C, and D).
- The supply must have a full complement of tests conducted as part of the certification, such as input current, leakage current, hi-pot, temperature, energy discharge test, transformer output characterization test (open-circuit voltage, short-circuit performance), and abnormal testing (to include stalled-fan tests and voltage-select-switch mismatch).
- The enclosure must meet fire enclosure mechanical test requirements per clauses 2.9.1 and 4.2 of the above-mentioned standard.
- Production hi-pot testing must be included as a part of the certification and indicated as such in the certification report.
- There must not be unusual or difficult conditions of acceptability such as mandatory additional cooling or power de-rating. The insulation system shall not have temperatures exceeding their rating when tested in the end product.
- The certification mark shall be marked on each power supply.
- The power supply must be evaluated for operator-accessible secondary outputs (reinforced insulation) that meet the requirements for SELV.
- The proper polarity between the AC input receptacle and any printed wiring boards connections must be maintained (that is, brown=line, blue=neutral, and green=earth/chassis).
- The fan shall be protected by a guard to prevent contact by a finger in compliance with UL accessibility requirements.

8.2 International - REQUIRED

The vendor must provide a complete CB certificate and test report to IEC 60950-1. The CB report must include ALL CB member country national deviations as appropriate for the target market. All evaluations and certifications must be for reinforced insulation between primary and secondary circuits.

The power supply must meet the RoHS requirements for the European Union, Peoples Republic of China and other countries which have adopted the RoHS requirements for banned materials.



8.3 Proscribed Materials

The following materials must not be used during design and/or manufacturing of this product:

- Cadmium should not be used in painting or plating - REQUIRED.
- Quaternary salt and PCB electrolytic capacitors shall not be used - REQUIRED.
- CFC's or HFC's shall not be used in the design or manufacturing process - REQUIRED.
- Mercury shall not be used - REQUIRED.
- Some geographies require lead free or RoHS compliant power supplies - REQUIRED.

8.4 Catastrophic Failure Protection - RECOMMENDED

Should a component failure occur, the power supply should not exhibit any of the following:

- Flame
- Excessive smoke
- Charred PCB
- Fused PCB conductor
- Startling noise
- Emission of molten material
- Earth ground fault (short circuit to ground or chassis enclosure)

§



9 Reliability

9.1 Reliability - RECOMMENDED

The de-rating process promotes quality and high reliability. All electronic components should be designed with conservative device de-ratings for use in commercial and industrial environments.

Electrolytic capacitor and fan lifetime and reliability should be considered in the design as well.

§

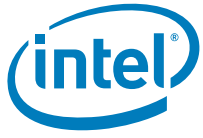

Reliability



10 CFX12V Specific Guidelines 1.41

For Compact Form Factor with 12-volt connector power supplies.

10.1 Typical Power Distribution - RECOMMENDED

DC output power requirements and distributions will vary based on specific system options and implementation.

Significant dependencies include the quantity and types of processors, memory, add-in card slots, and peripheral bays, as well as support for advanced graphics or other features. Figure 9 through Figure 12 shows the power distribution and cross loading tables for power supplies in the range of 180 W to 300 W. These are recommendations but it is ultimately the responsibility of the designer to define a power budget for a given target product and market.

Figure 9. Cross Loading Graph for 180 W Configurations

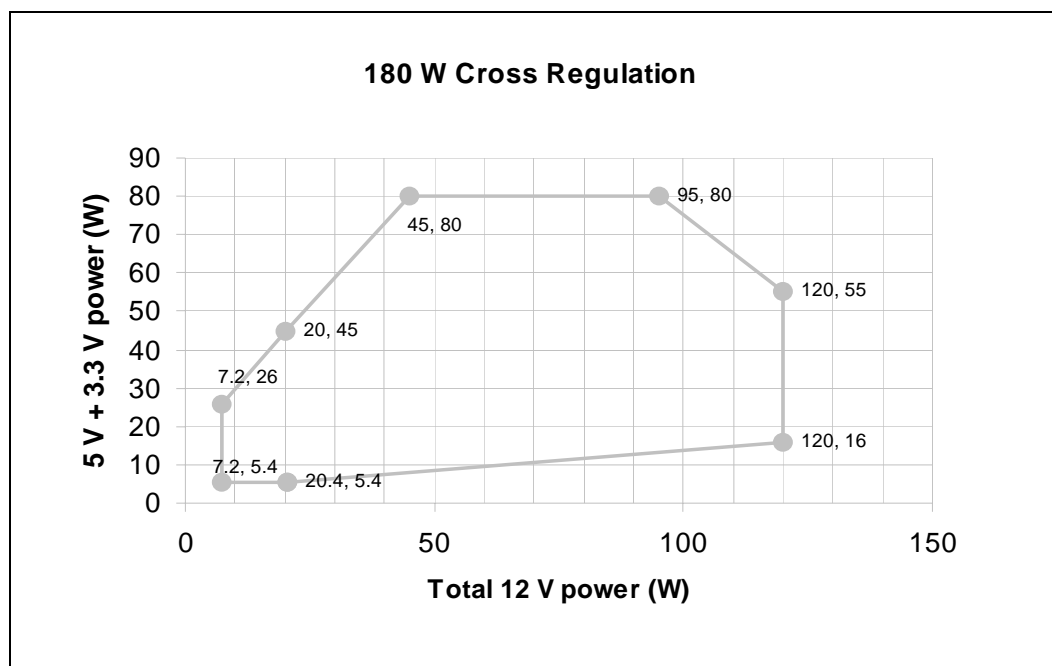

Table 33. Typical Power Distribution for 180 W Configurations

Output	Minimum Current (A)	Rated Current (A)	Peak Current (A)
+12 VDC ¹	0.6	10.0	13.0
+5 VDC ²	0.2	14.0	-



Table 33. Typical Power Distribution for 180 W Configurations

Output	Minimum Current (A)	Rated Current (A)	Peak Current (A)
+3.3 VDC	0.1	13.0	-
-12 VDC	0	0.3	-
+5 VSB ¹	0	2.0	2.5

NOTES:

1. Peak currents may last up to 17 seconds with not more than one occurrence per minute.
2. Total combined output of 3.3 V and 5 V is ≤ 80 W.

Figure 10. Cross Loading Graph for 220 W Configurations

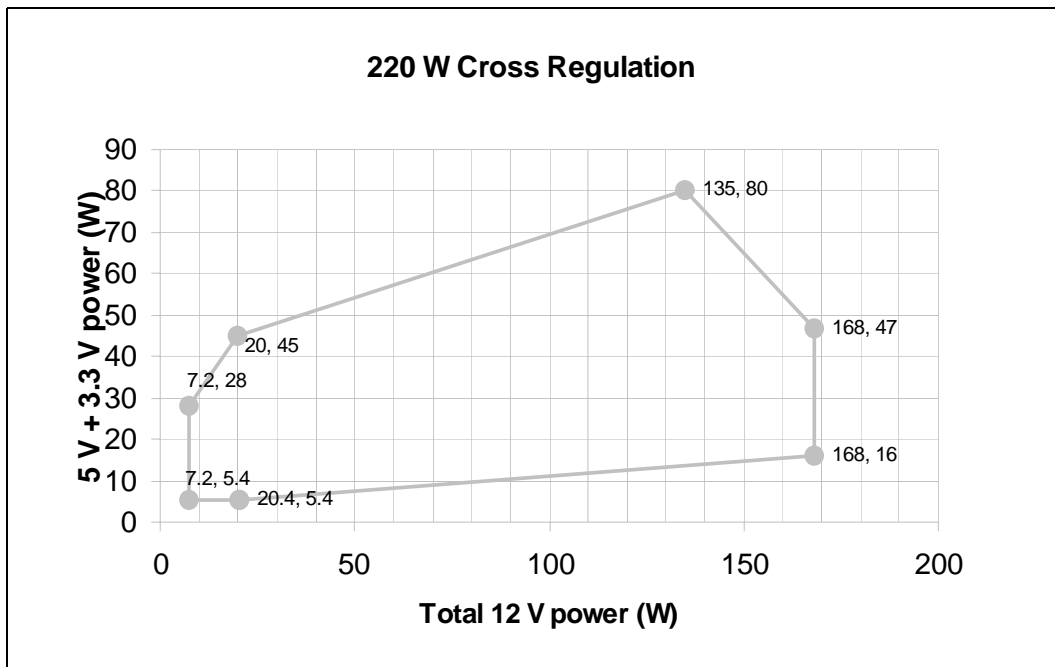

Table 34. Typical Power Distribution for 220 W Configurations

Output	Minimum Current (A)	Rated Current (A)	Peak Current (A)
+12 VDC ¹	0.6	14.0	16.0
+5 VDC ²	0.2	14.0	-
+3.3 VDC	0.1	13.0	-
-12 VDC	0	0.3	-
+5 VSB ¹	0	2.0	2.5

NOTES:

1. Peak currents may last up to 17 seconds with not more than one occurrence per minute.
2. Total combined output of 3.3 V and 5 V is ≤ 80 W.



Figure 11. Cross Loading Graph for 270 W Configurations

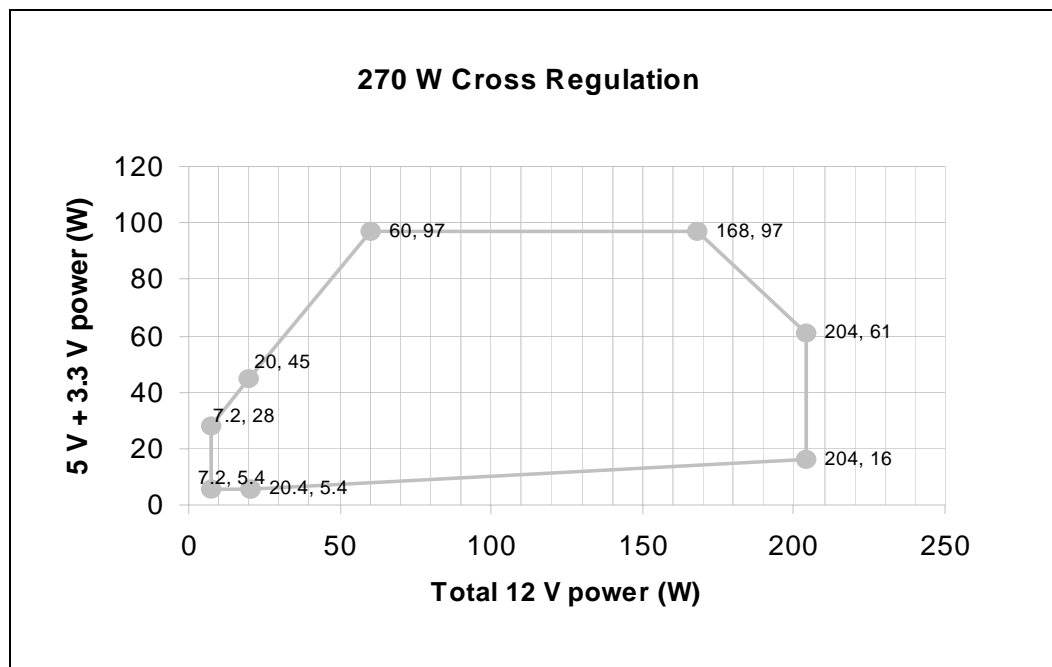

Table 35. Typical Power Distribution for 270 W Configurations

Output	Minimum Current (A)	Rated Current (A)	Peak Current (A)
+12 VDC ¹	0.6	17 A	18 A
+5 VDC ²	0.2	15.0	-
+3.3 VDC	0.1	19.0	-
-12 VDC	0	0.3	-
+5 VSB ¹	0	2.0	2.5

NOTES:

1. Peak currents may last up to 17 seconds with not more than one occurrence per minute.
2. Total combined output of 3.3 V and 5 V is ≤ 97 W.

Figure 12. Cross Loading Graph for 300 W Configurations

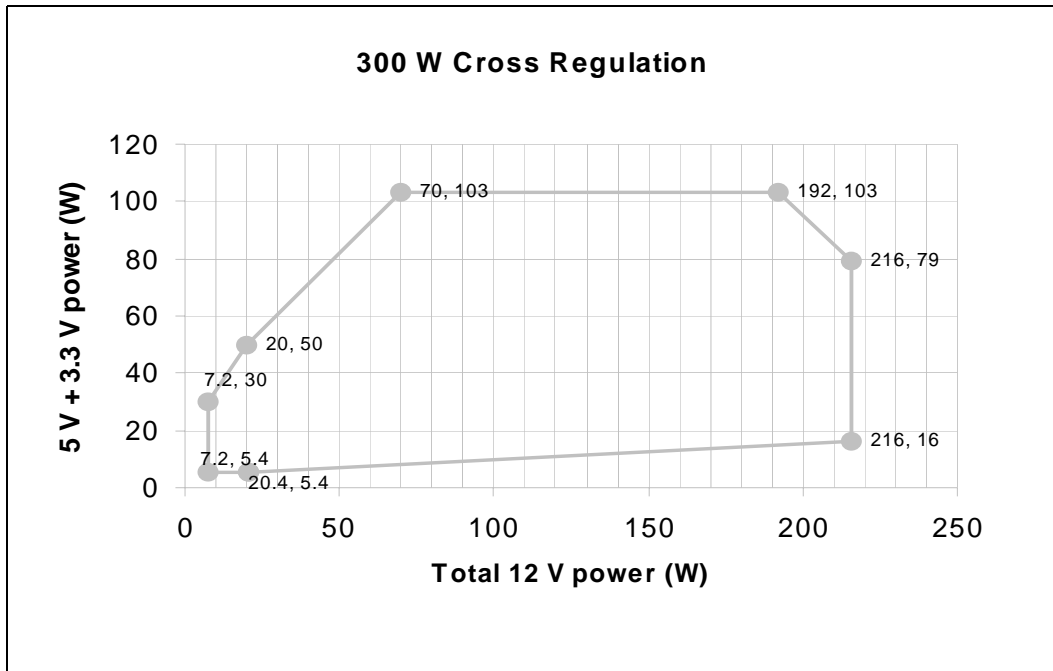

Table 36. Typical Power Distribution for 300 W Configurations

Output	Minimum Current (A)	Rated Current (A)	Peak Current (A)
+12 V1DC	0.1	11.0	-
+12 V2DC ¹	0.5	8.0	13.0
+5 VDC ²	0.2	15.0	-
+3.3 VDC	0.1	21.0	-
-12 VDC	0	0.3	-
+5 VSB ³	0	2.0	2.5

NOTES:

- 12V2 supports processor power requirements and must have a separate current limit and provide 19 A peak current lasting for 10 ms. The minimum voltage during peak is > 10.8 VDC.
- Total combined output of 3.3 V and 5 V is ≤ 103 W.
- Peak currents may last up to 17 seconds with not more than one occurrence per minute.

Table 37. 180 W Loading for Efficiency Measurements¹

Loading	+12 V	+5 V	+3.3 V	-12 V	+5 VSB
Full (A)	8.4	8.4	7.8	0.3	1.7
Typical (A)	4.2	4.2	3.9	0.1	0.8
Light (A)	1.7	1.7	1.6	0.1	0.3

NOTES:

- Loading calculated by method available at <http://www.efficientpowersupplies.org>.

Table 38. 220 W Loading for Efficiency Measurements¹

Loading	+12 V	+5 V	+3.3 V	-12 V	+5 VSB
Full (A)	11.8	8.3	7.7	0.3	1.7
Typical (A)	5.9	4.2	3.9	0.1	0.8
Light (A)	2.4	1.7	1.5	0.1	0.3

NOTES:

1. Loading calculated by method available at <http://www.efficientpowersupplies.org>.

Table 39. 270 W Loading for Efficiency Measurements¹

Loading	+12 V	+5 V	+3.3 V	-12 V	+5 VSB
Full (A)	14.6	9.1	11.5	0.3	1.7
Typical (A)	7.3	4.5	5.7	0.1	0.9
Light (A)	2.9	1.8	2.3	0.1	0.3

NOTES:

1. Loading calculated by method available at <http://www.efficientpowersupplies.org>.

Table 40. 300 W Loading for Efficiency Measurements¹

Loading	+12 V1	+12 V2	+5 V	+3.3 V	-12 V	+5 VSB
Full (A)	9.6	7.0	9.3	13.0	0.3	1.7
Typical (A)	4.8	3.5	4.7	6.5	0.1	0.9
Light (A)	1.9	1.4	1.9	2.6	0.1	0.3

NOTES:

1. Loading calculated by method available at <http://www.efficientpowersupplies.org>.

10.2 Physical Dimensions - REQUIRED

The power supply shall be enclosed and meet the physical outline shown in [Figure 13](#).

Figure 13. CFX12V Mechanical Outline

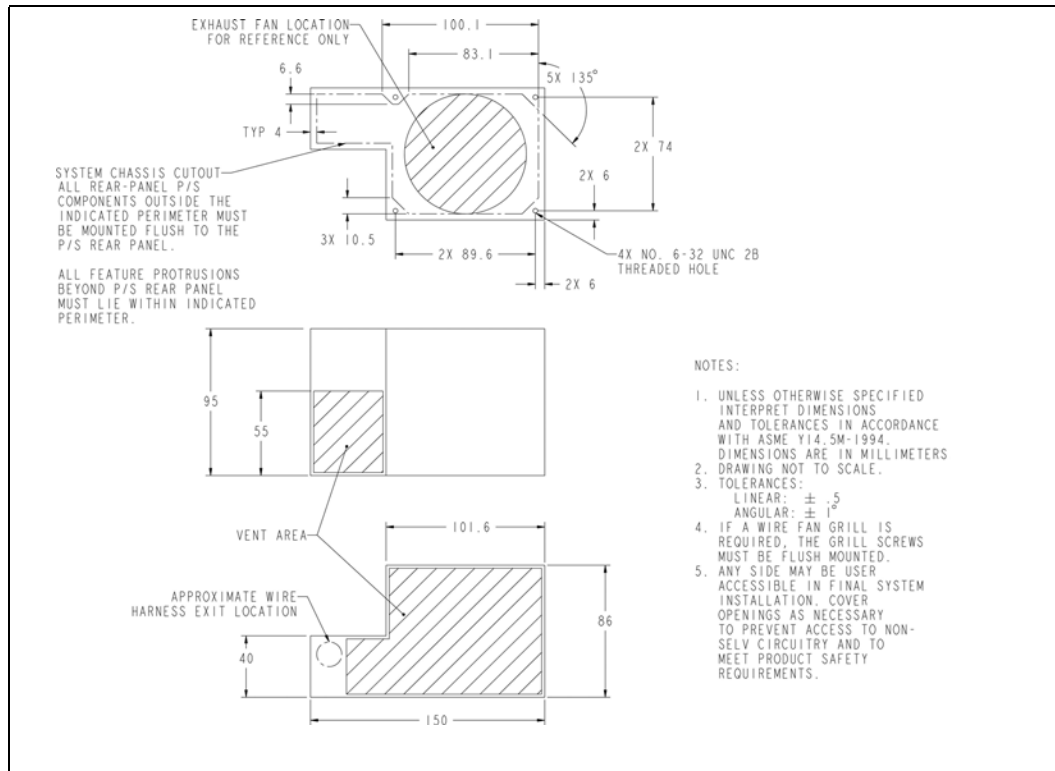

S



11 LFX12V Specific Guidelines 1.21

For Low Profile Form Factor with 12-volt connector power supplies.

11.1 Typical Power Distribution - RECOMMENDED

DC output power requirements and distributions will vary based on specific system options and implementation.

Significant dependencies include the quantity and types of processors, memory, add-in card slots, and peripheral bays, as well as support for advanced graphics or other features. Figure 14 through Figure 16 shows the power distribution and cross loading tables for power supplies in the range of 180 W to 270 W. These are recommendations but it is ultimately the responsibility of the designer to define a power budget for a given target product and market.

Figure 14. Cross Loading Graph for 180 W Configurations

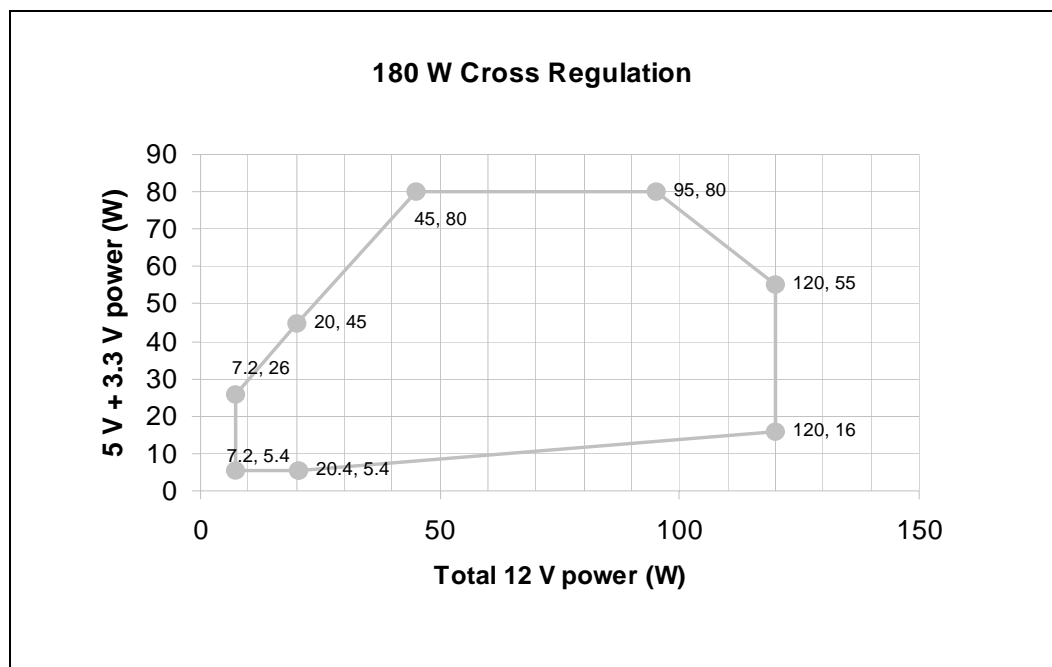

Table 41. Typical Power Distribution for 180 W Configurations

Output	Minimum Current (A)	Rated Current (A)	Peak Current (A)
+12 VDC ¹	0.6	10.0	13.0
+5 VDC ²	0.2	14.0	-



Table 41. Typical Power Distribution for 180 W Configurations

Output	Minimum Current (A)	Rated Current (A)	Peak Current (A)
+3.3 VDC	0.1	13.0	-
-12 VDC	0	0.3	-
+5 VSB ¹	0	2.0	2.5

NOTES:

1. Peak currents may last up to 17 seconds with not more than one occurrence per minute.
2. Total combined output of 3.3 V and 5 V is ≤ 80 W.

Figure 15. Cross Loading Graph for 220 W Configurations

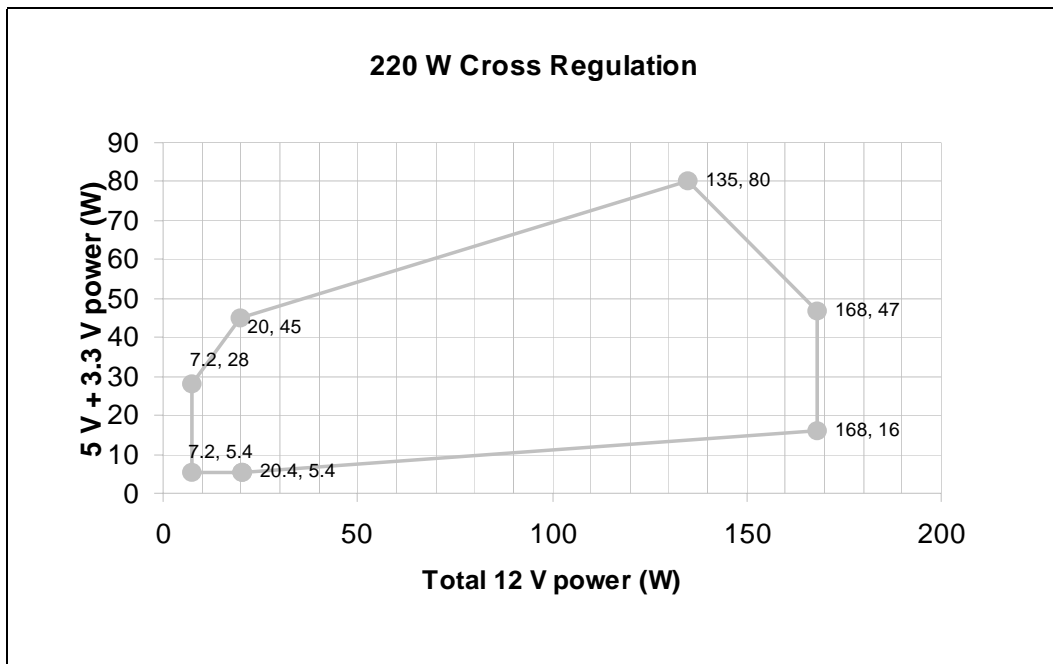

Table 42. Typical Power Distribution for 220 W Configurations

Output	Minimum Current (A)	Rated Current (A)	Peak Current (A)
+12 VDC ¹	0.6	14.0	16.0
+5 VDC ²	0.2	14.0	-
+3.3 VDC	0.1	13.0	-
-12 VDC	0	0.3	-
+5 VSB ¹	0	2.0	2.5

NOTES:

1. Peak currents may last up to 17 seconds with not more than one occurrence per minute.
2. Total combined output of 3.3 V and 5 V is ≤ 80 W.



Figure 16. Cross Loading Graph for 270 W Configurations

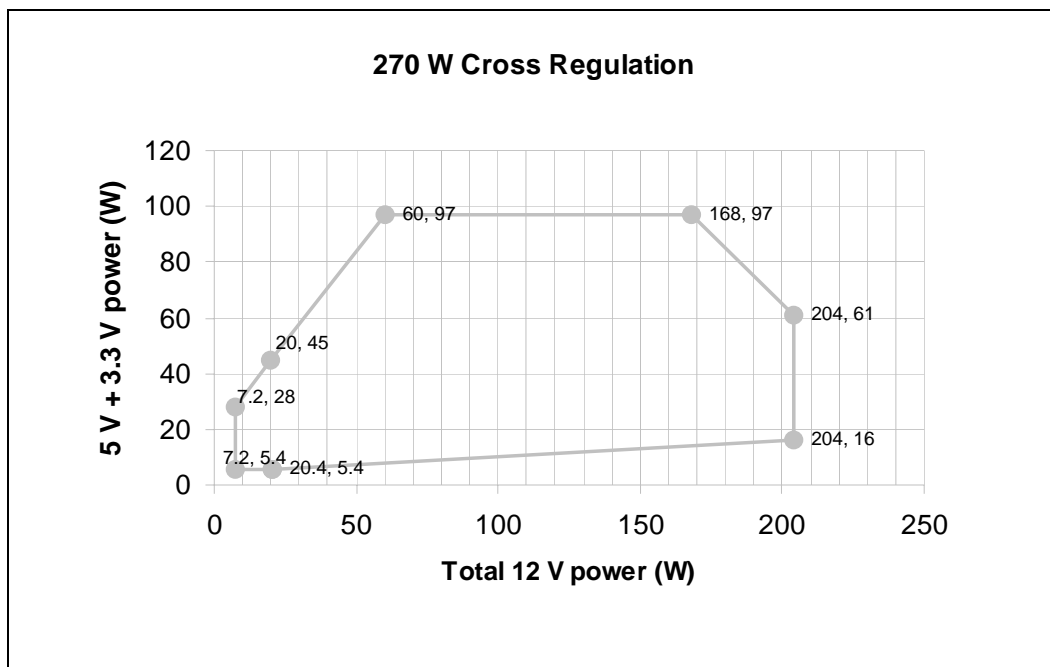

Table 43. Typical Power Distribution for 270 W Configurations

Output	Minimum Current (A)	Rated Current (A)	Peak Current (A)
+12 VDC ¹	0.6	17 A	18 A
+5 VDC ²	0.2	15.0	-
+3.3 VDC	0.1	19.0	-
-12 VDC	0	0.3	-
+5 VSB ¹	0	2.0	2.5

NOTES:

1. Peak currents may last up to 17 seconds with not more than one occurrence per minute.
2. Total combined output of 3.3 V and 5 V is ≤ 97 W.

Table 44. 180 W Loading for Efficiency Measurements¹

Loading	+12 V	+5 V	+3.3 V	-12 V	+5 VSB
Full (A)	8.4	8.4	7.8	0.3	1.7
Typical (A)	4.2	4.2	3.9	0.1	0.8
Light (A)	1.7	1.7	1.6	0.1	0.3

NOTES:

1. Loading calculated by method available at <http://www.efficientpowersupplies.org>.



Table 45. 220 W Loading for Efficiency Measurements¹

Loading	+12 V	+5 V	+3.3 V	-12 V	+5 VSB
Full (A)	11.8	8.3	7.7	0.3	1.7
Typical (A)	5.9	4.2	3.9	0.1	0.8
Light (A)	2.4	1.7	1.5	0.1	0.3

NOTES:

1. Loading calculated by method available at <http://www.efficientpowersupplies.org>.

Table 46. 270 W Loading for Efficiency Measurements¹

Loading	+12 V	+5 V	+3.3 V	-12 V	+5 VSB
Full (A)	14.6	9.1	11.5	0.3	1.7
Typical (A)	7.3	4.5	5.7	0.1	0.9
Light (A)	2.9	1.8	2.3	0.1	0.3

NOTES:

1. Loading calculated by method available at <http://www.efficientpowersupplies.org>.

11.2 Physical Dimensions - REQUIRED

The power supply shall be enclosed and meet the physical outline shown in [Figure 17](#), applicable. Mechanical details are shown in [Figure 18](#). Details on the power supply slot feature are shown in [Figure 19](#). The recommended chassis slot feature details are shown in [Figure 20](#).

Figure 17. Mechanical Outline

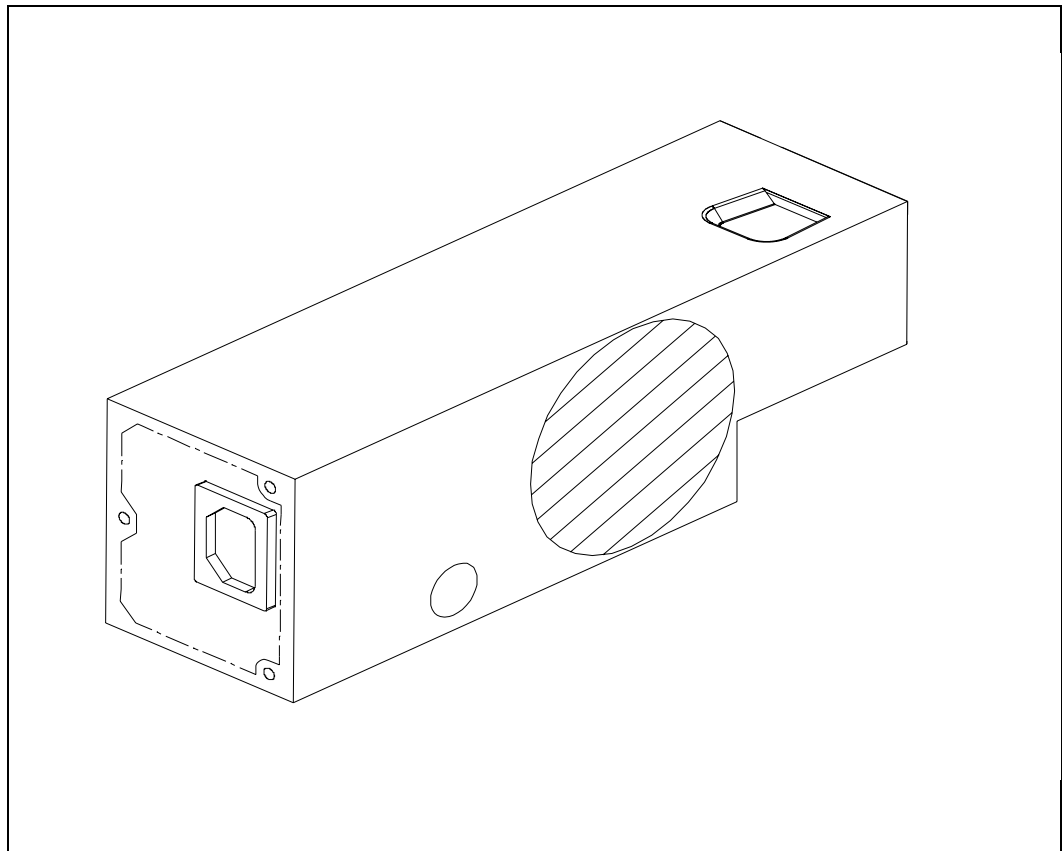

Figure 18. Mechanical Details

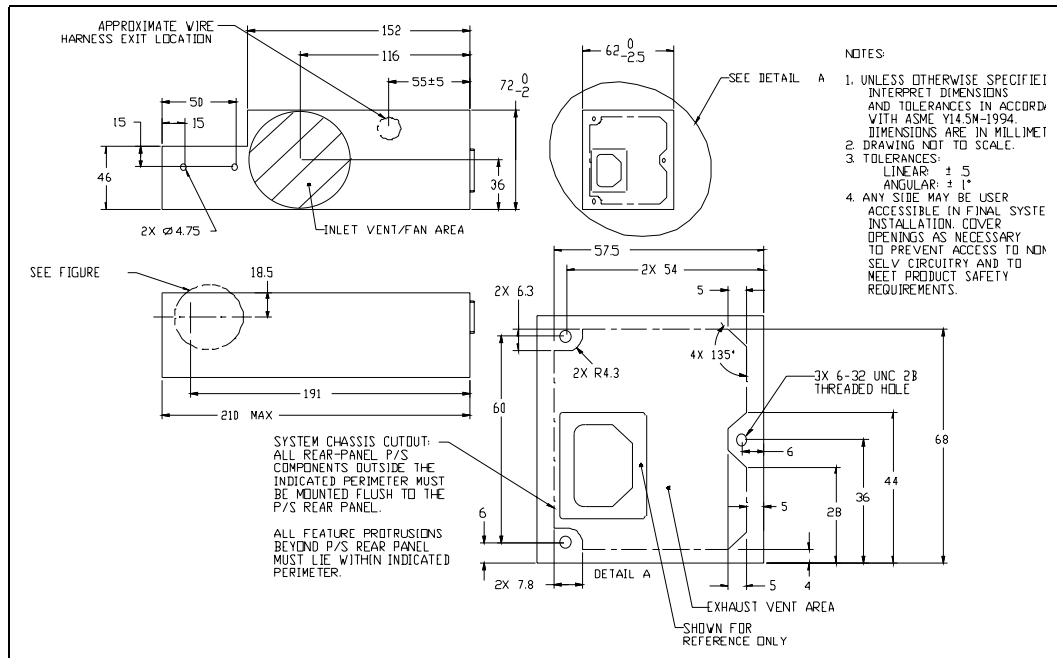

Figure 19. PSU Slot Feature Detail

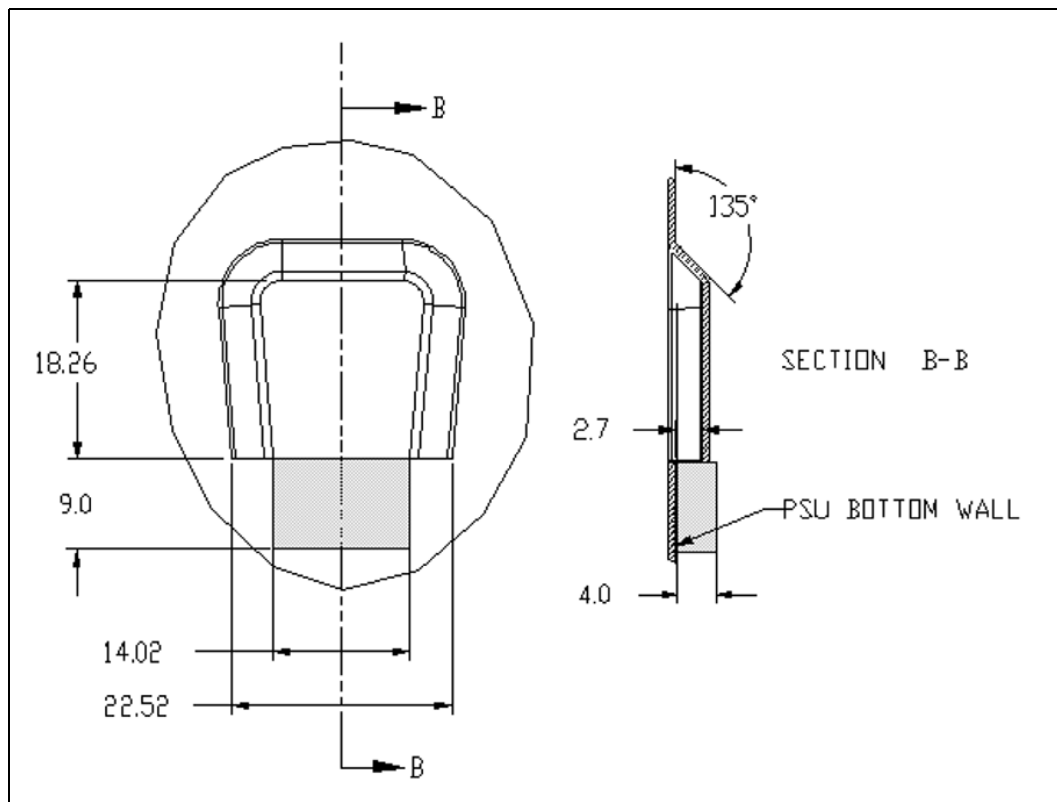
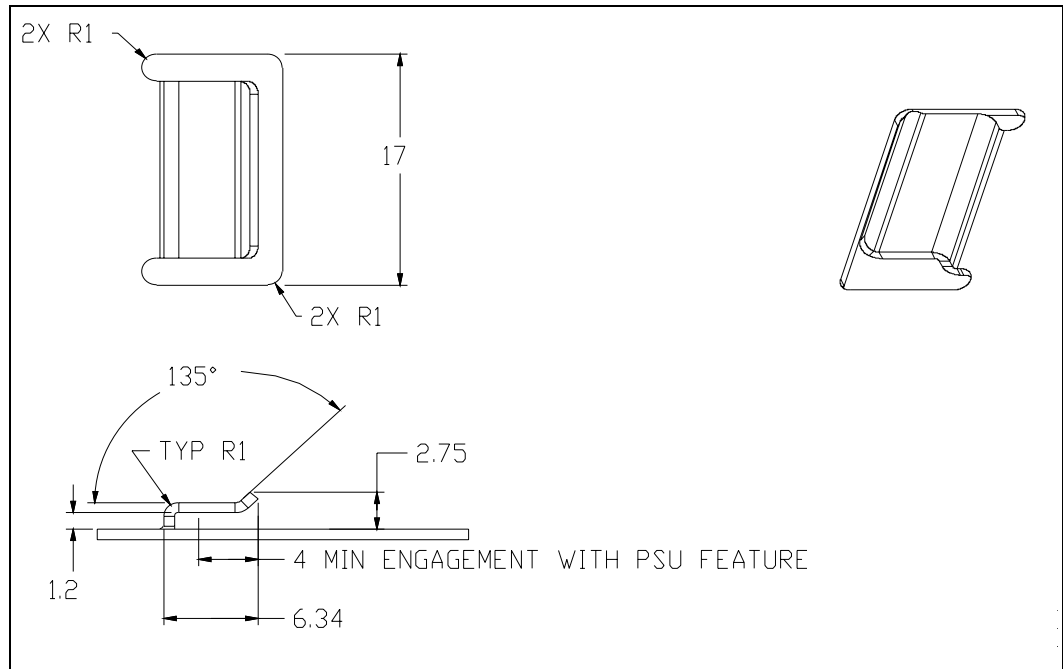

Figure 20. Recommended Chassis Tab Feature







12 ATX12V Specific Guidelines 2.31

For ATX Form Factor with 12-volt connector power supplies.

12.1 Typical Power Distribution - RECOMMENDED

DC output power requirements and distributions will vary based on specific system options and implementation.

Significant dependencies include the quantity and types of processors, memory, add-in card slots, and peripheral bays, as well as support for advanced graphics or other features. Figure 22 through Figure 26 shows the power distribution and cross loading tables for power supplies in the range of 180 W to 450 W. These are recommendations but it is ultimately the responsibility of the designer to define a power budget for a given target product and market.

Figure 21. Cross Loading Graph for 180 W Configurations

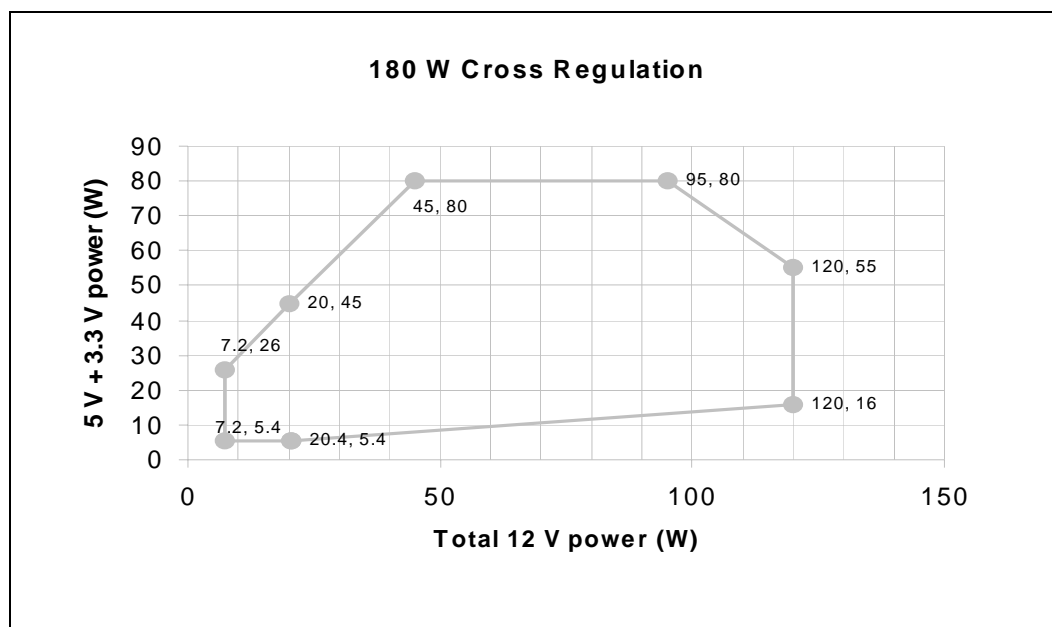

Table 47. Typical Power Distribution for 180 W Configurations

Output	Minimum Current (A)	Maximum Current (A)	Peak Current (A)
+12 VDC ¹	0.6	10.0	13.0
+5 VDC ²	0.2	14.0	-



Table 47. Typical Power Distribution for 180 W Configurations

Output	Minimum Current (A)	Maximum Current (A)	Peak Current (A)
+3.3 VDC	0.1	13.0	-
-12 VDC	0	0.3	-
+5 VSB ¹	0	2.0	2.5

NOTES:

1. Peak currents may last up to 17 seconds with not more than one occurrence per minute.
2. Total combined output of 3.3 V and 5 V is ≤ 80 W.

Figure 22. Cross Loading Graph for 220 W Configurations

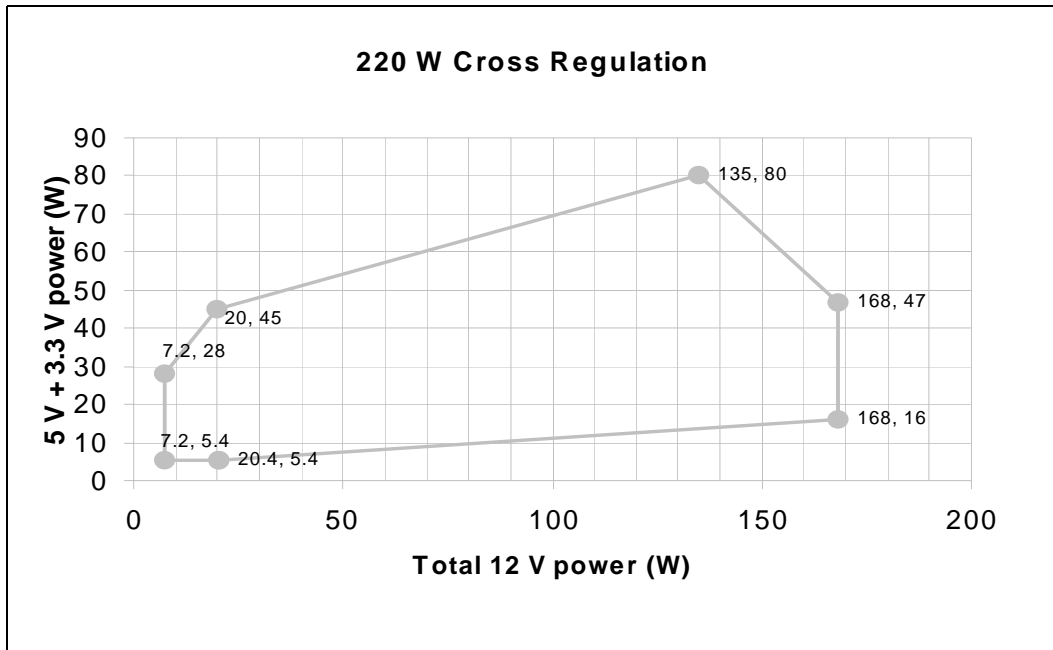

Table 48. Typical Power Distribution for 220 W Configurations

Output	Minimum Current (A)	Maximum Current (A)	Peak Current (A)
+12 VDC ¹	0.6	14.0	16.0
+5 VDC ²	0.2	14.0	-
+3.3 VDC	0.1	13.0	-
-12 VDC	0	0.3	-
+5 VSB ¹	0	2.0	2.5

NOTES:

1. Peak currents may last up to 17 seconds with not more than one occurrence per minute.
2. Total combined output of 3.3 V and 5 V is ≤ 80 W.



Figure 23. Cross Loading Graph for 270 W Configurations

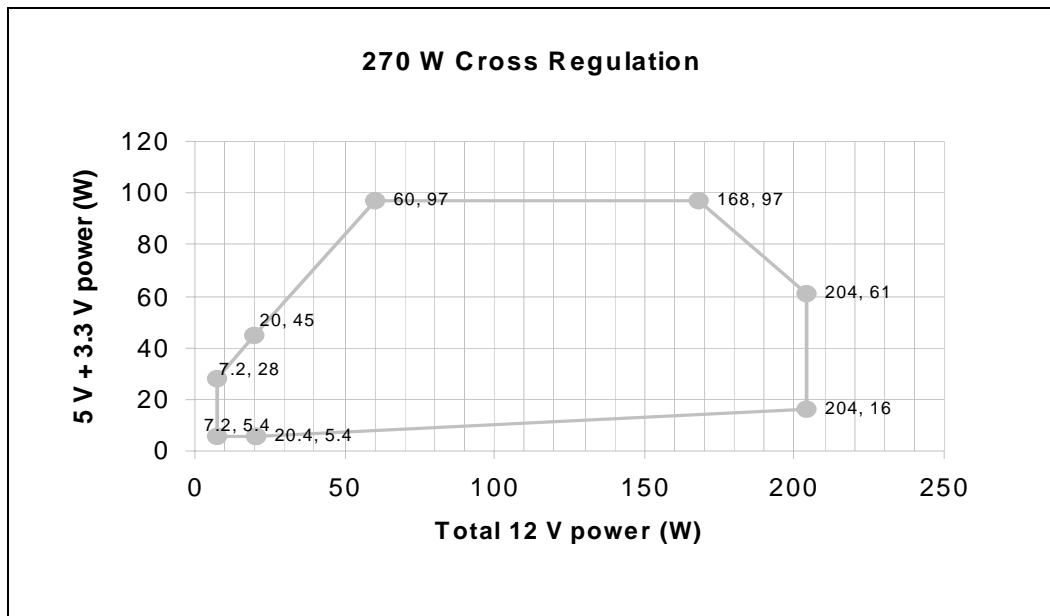

Table 49. Typical Power Distribution for 270 W Configurations

Output	Minimum Current (A)	Maximum Current (A)	Peak Current (A)
+12 VDC ¹	0.6	17.0	18.0
+5 VDC ²	0.2	15.0	-
+3.3 VDC	0.1	19.0	-
-12 VDC	0	0.3	-
+5 VSB ¹	0	2.0	2.5

NOTES:

1. Peak currents may last up to 17 seconds with not more than one occurrence per minute.
2. Total combined output of 3.3 V and 5 V is ≤ 97 W.

Figure 24. Cross Loading Graph for 300 W Configurations

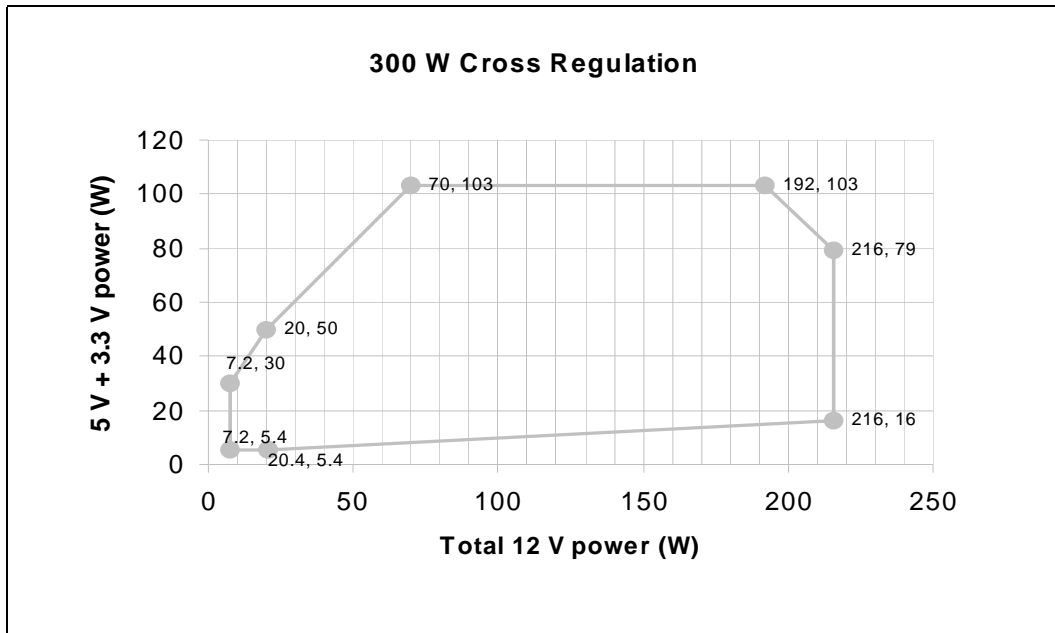

Table 50. Typical Power Distribution for 300 W Configurations

Output	Minimum Current (A)	Maximum Current (A)	Peak Current (A)
+12 V1DC ^{1, 4}	0.1	11.0	13.0
+12 V2DC ^{1, 2}	0.5	8.0	13.0
+5 VDC ³	0.2	15.0	-
+3.3 VDC	0.1	21.0	-
-12 VDC	0	0.3	-
+5 VSB ⁴	0	2.5	3.5

NOTES:

- 12V1DC and 12V2DC should have separate current limit circuits.
- 12V2DC supports processor power requirements and must have a separate current limit and provide 13 A peak current for 10 ms; minimum voltage during peak is > 10.8 VDC.
- Total combined output of 3.3 V and 5 V is ≤ 103 W.
- Peak currents may last up to 17 seconds with not more than one occurrence per minute.



Figure 25. Cross Loading Graph for 350 W Configurations

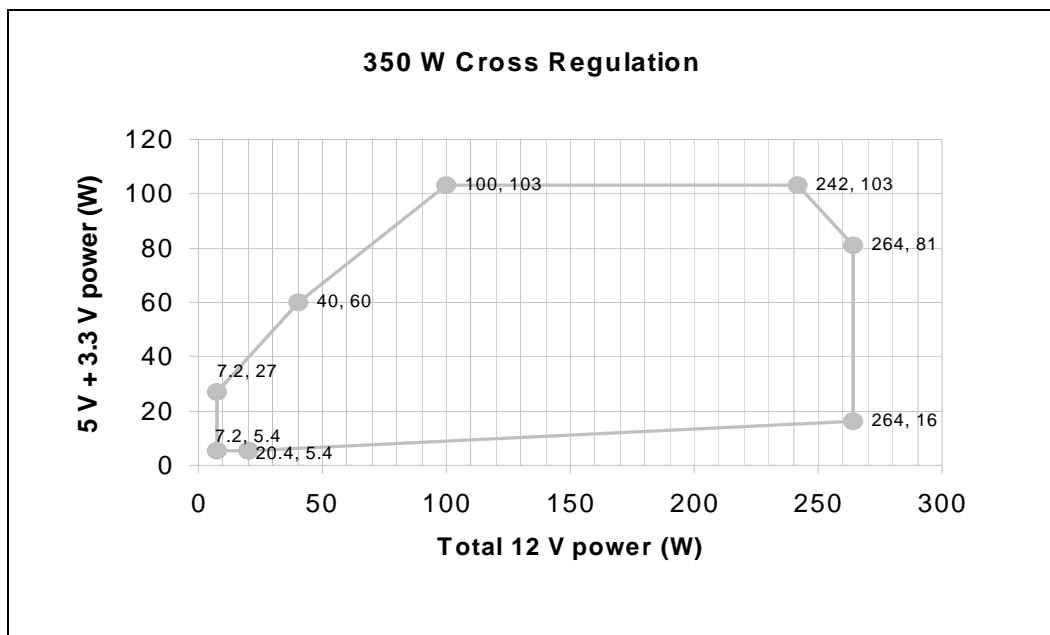

Table 51. Typical Power Distribution for 350 W Configurations

Output	Minimum Current (A)	Maximum Current (A)	Peak Current (A)
+12 V1DC ^{1, 4}	0.1	11.0	15.0
+12 V2DC ^{1, 2}	0.5	14.0	18.0
+5 VDC ³	0.2	15.0	-
+3.3 VDC	0.1	21.0	-
-12 VDC	0	0.3	-
+5 VSB ⁴	0	2.5	3.5

NOTES:

- 12V1DC and 12V2DC should have separate current limit circuits.
- 12V2DC supports processor power requirements and must have a separate current limit and provide 16.5 A peak current for 10 ms; minimum voltage during peak is > 10.8 VDC.
- Total combined output of 3.3 V and 5 V is ≤ 103 W.
- Peak currents may last up to 17 seconds with not more than one occurrence per minute.

Figure 26. Cross Loading Graph for 400 W Configurations

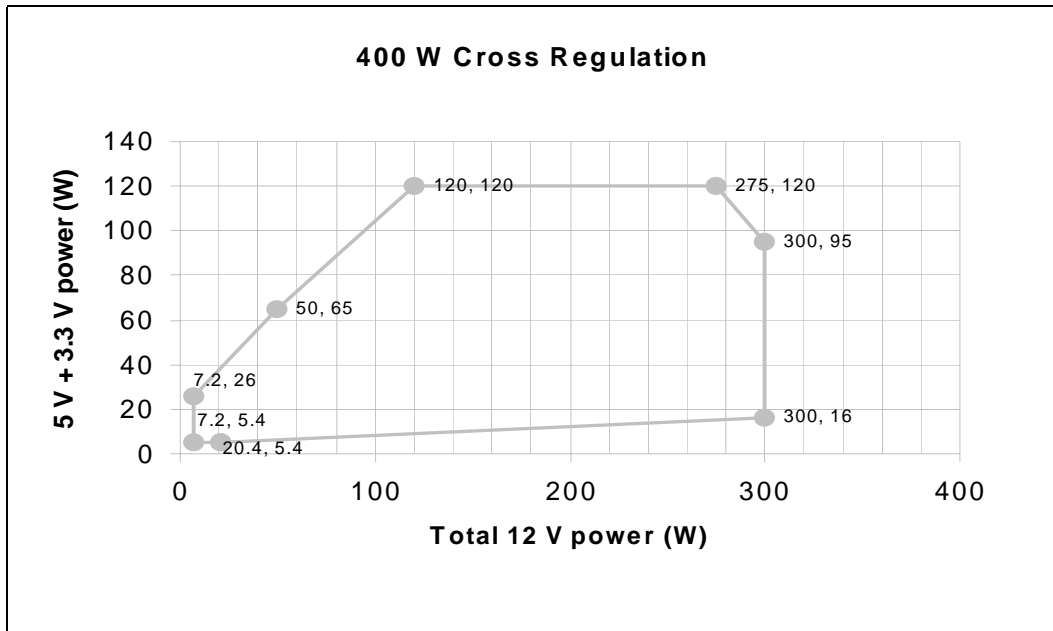

Table 52. Typical Power Distribution for 400 W Configurations

Output	Minimum Current (A)	Maximum Current (A)	Peak Current (A)
+12 V1DC ¹	0.1	17.0	-
+12 V2DC ^{1, 2}	0.5	14.0	18.0
+5 VDC ³	0.2	15.0	-
+3.3 VDC	0.1	24.0	-
-12 VDC	0	0.3	-
+5 VSB ⁴	0	2.5	3.5

NOTES:

- 12V1DC and 12V2DC should have separate current limit circuits.
- 12V2DC supports processor power requirements and must have a separate current limit and provide 16.5 A peak current for 10 ms; minimum voltage during peak is > 10.8 VDC.
- Total combined output of 3.3 V and 5 V is ≤ 120 W.
- Peak currents may last up to 17 seconds with not more than one occurrence per minute.



Figure 27. Cross Loading Graph for 450 W Configurations

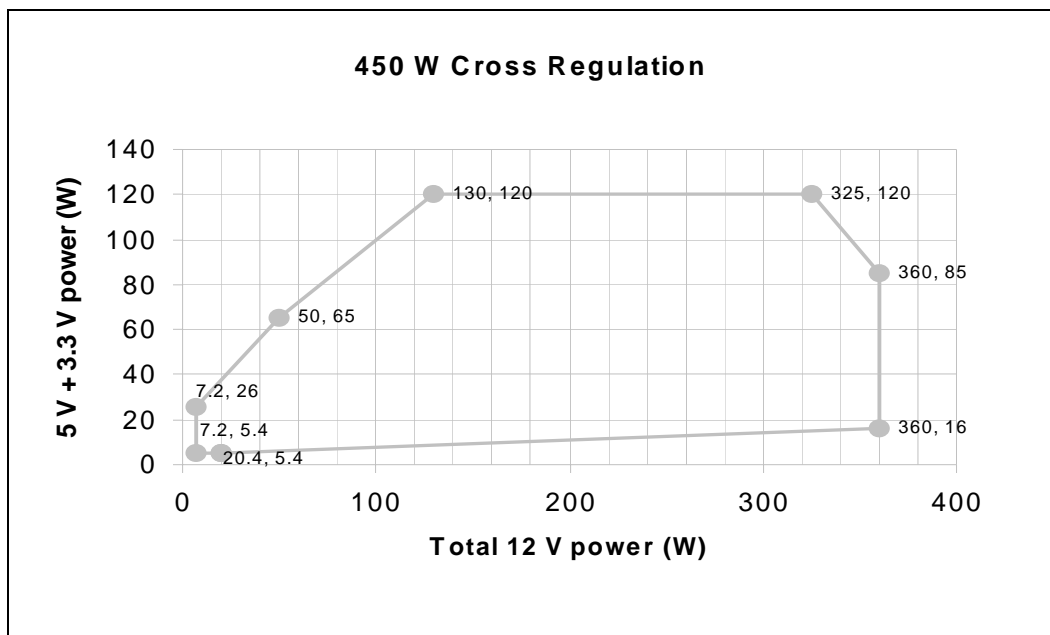

Table 53. Typical Power Distribution for 450 W Configurations

Output	Minimum Current (A)	Maximum Current (A)	Peak Current (A)
+12 V1DC ¹	0.1	17.0	-
+12 V2DC ^{1, 2}	0.5	16.0	19.0
+5 VDC ³	0.2	15.0	-
+3.3 VDC	0.1	24.0	-
-12 VDC	0	0.3	-
+5 VSB ⁴	0	2.5	3.5

- NOTES:**
- 12V1DC and 12V2DC should have separate current limit circuits.
 - 12V2DC supports processor power requirements and must have a separate current limit and provide 16.5 A peak current for 10 ms; minimum voltage during peak is > 10.8 VDC.
 - Total combined output of 3.3 V and 5 V is ≤ 120 W.
 - Peak currents may last up to 17 seconds with not more than one occurrence per minute.

Table 54. 180 W Loading for Efficiency Measurements¹

Loading	+12 V	+5 V	+3.3 V	-12 V	+5 VSB
Full (A)	8.4	8.4	7.8	0.3	1.7
Typical (A)	4.2	4.2	3.9	0.1	0.8
Light (A)	1.7	1.7	1.6	0.1	0.3

- NOTES:**
- Loading calculated by method available at <http://www.efficientpowersupplies.org>.

Table 55. 220 W Loading for Efficiency Measurements¹

Loading	+12 V	+5 V	+3.3 V	-12 V	+5 VSB
Full (A)	11.8	8.3	7.7	0.3	1.7
Typical (A)	5.9	4.2	3.9	0.1	0.8
Light (A)	2.4	1.7	1.5	0.1	0.3

NOTES:

1. Loading calculated by method available at <http://www.efficientpowersupplies.org>.

Table 56. 270 W Loading for Efficiency Measurements¹

Loading	+12 V	+5 V	+3.3 V	-12 V	+5 VSB
Full (A)	14.6	9.1	11.5	0.3	1.7
Typical (A)	7.3	4.5	5.7	0.1	0.9
Light (A)	2.9	1.8	2.3	0.1	0.3

NOTES:

1. Loading calculated by method available at <http://www.efficientpowersupplies.org>.

Table 57. 300 W Loading for Efficiency Measurements¹

Loading	+12 V1	+12 V2	+5 V	+3.3 V	-12 V	+5 VSB
Full (A)	9.6	7.0	9.3	13.0	0.3	1.7
Typical (A)	4.8	3.5	4.7	6.5	0.1	0.9
Light (A)	1.9	1.4	1.9	2.6	0.1	0.3

NOTES:

1. Loading calculated by method available at <http://www.efficientpowersupplies.org>.

Table 58. 350 W Loading for Efficiency Measurements¹

Loading	+12 V1	+12 V2	+5 V	+3.3 V	-12 V	+5 VSB
Full (A)	9.5	11.2	9.2	12.9	0.3	2.1
Typical (A)	4.7	5.6	4.6	6.4	0.1	1.1
Light (A)	1.9	2.2	1.8	2.6	0.1	0.4

NOTES:

1. Loading calculated by method available at <http://www.efficientpowersupplies.org>.

Table 59. 400 W Loading for Efficiency Measurements¹

Loading	+12 V1	+12 V2	+5 V	+3.3 V	-12 V	+5 VSB
Full (A)	14.0	9.9	9.6	15.4	0.2	2.1
Typical (A)	7.0	5.0	4.8	7.7	0.1	1.0
Light (A)	2.8	2.0	1.9	3.1	0.0	0.4

NOTES:

1. Loading calculated by method available at <http://www.efficientpowersupplies.org>.



Table 60. 450 W Loading for Efficiency Measurements¹

Loading	+12 V1	+12 V2	+5 V	+3.3 V	-12 V	+5 VSB
Full (A)	14.4	13.5	9.9	15.8	0.3	2.1
Typical (A)	7.2	6.8	4.9	7.9	0.1	1.1
Light (A)	2.9	2.7	2.0	3.2	0.1	0.4

NOTES:

1. Loading calculated by method available at <http://www.efficientpowersupplies.org>.

12.2 Physical Dimensions - REQUIRED

Figure 28. Power Supply Dimensions for Chassis that does not Require Top Venting

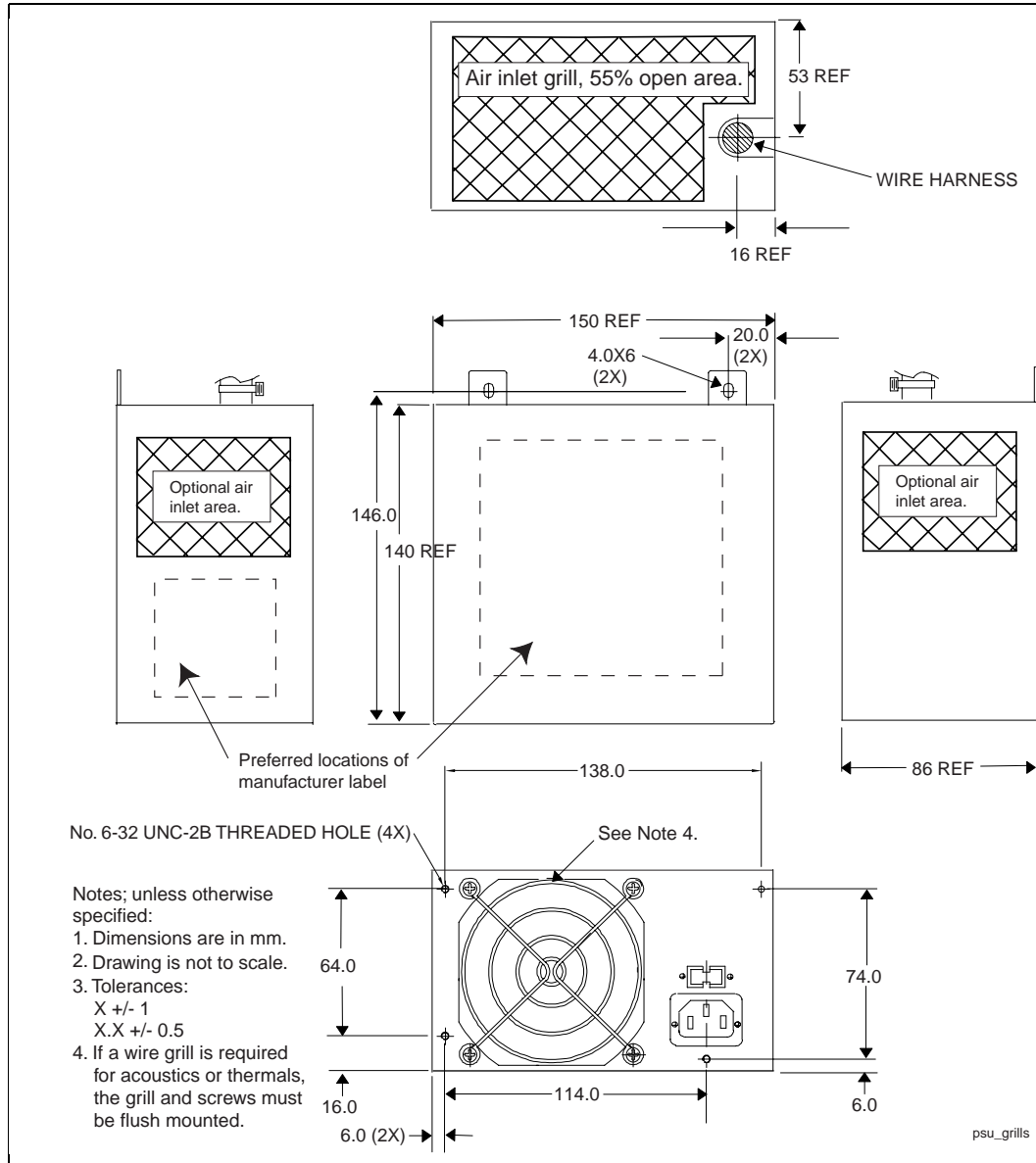
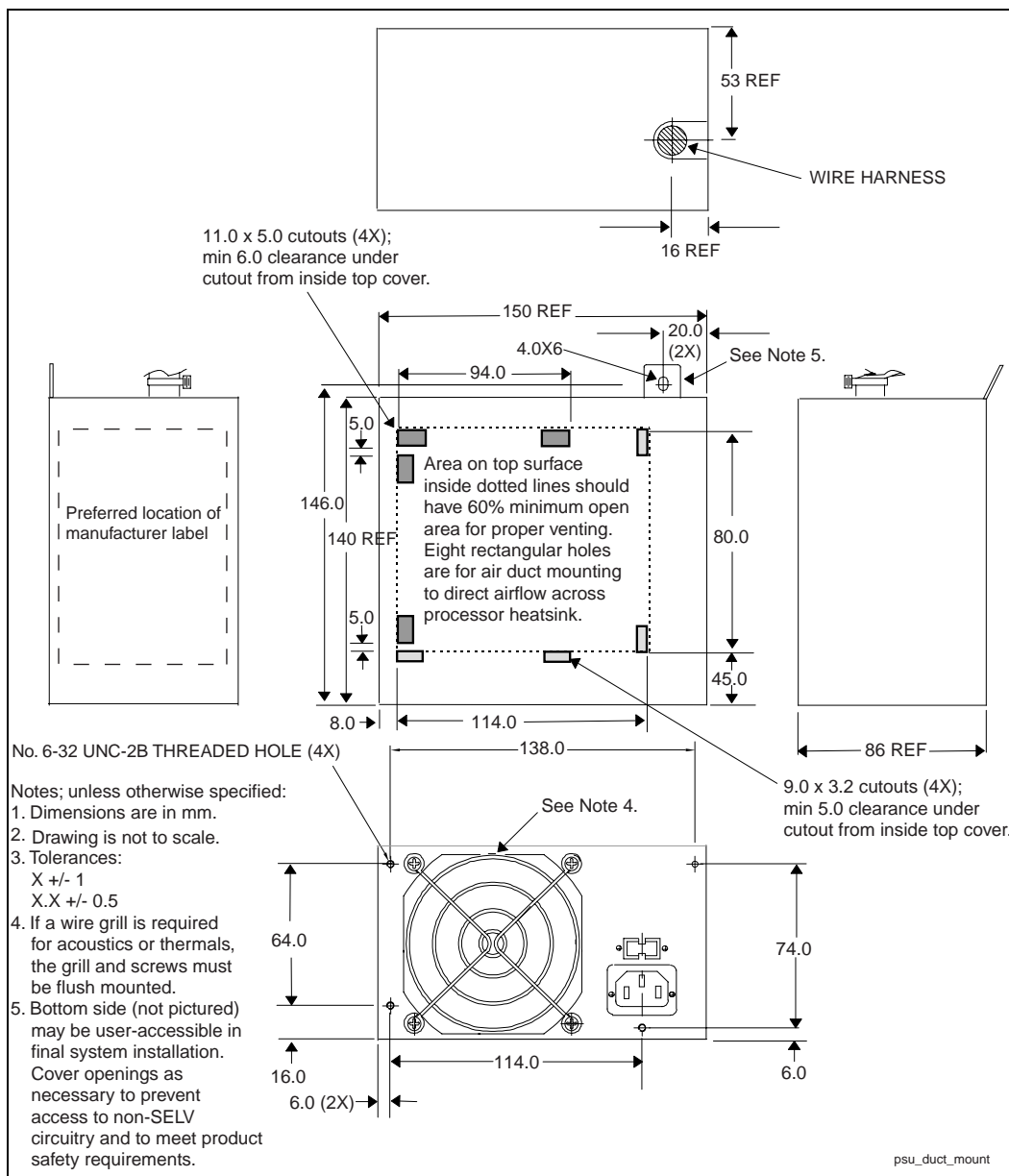



Figure 29. Power Supply Dimensions for Chassis that Require Top Venting







13 SFX12V Specific Guidelines 3.21

For Small Form Factor with 12-volt connector power supplies.

13.1 Typical Power Distribution - RECOMMENDED

DC output power requirements and distributions will vary based on specific system options and implementation.

Significant dependencies include the quantity and types of processors, memory, add-in card slots, and peripheral bays, as well as support for advanced graphics or other features. Figure 30 through Figure 33 shows the power distribution and cross loading tables for power supplies in the range of 180 W to 300W. These are recommendations but it is ultimately the responsibility of the designer to define a power budget for a given target product and market.

Figure 30. Cross Loading Graph for 180 W Configurations

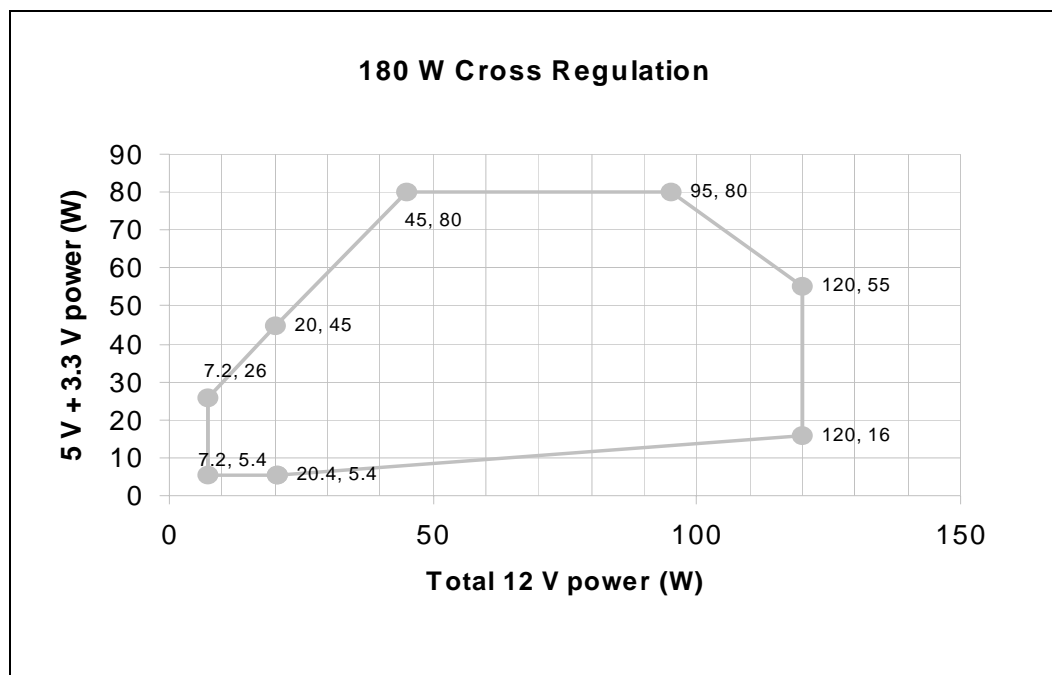

Table 61. Typical Power Distribution for 180 W Configurations

Output	Minimum Current (A)	Rated Current (A)	Peak Current (A)
+12 VDC ¹	0.6	10.0	13.0
+5 VDC ²	0.2	14.0	-



Table 61. Typical Power Distribution for 180 W Configurations

Output	Minimum Current (A)	Rated Current (A)	Peak Current (A)
+3.3 VDC	0.1	13.0	-
-12 VDC	0	0.3	-
+5 VSB ¹	0	2.0	2.5

NOTES:

1. Peak currents may last up to 17 seconds with not more than one occurrence per minute.
2. Total combined output of 3.3 V and 5 V is ≤ 80 W.

Figure 31. Cross Loading Graph for 220 W Configurations

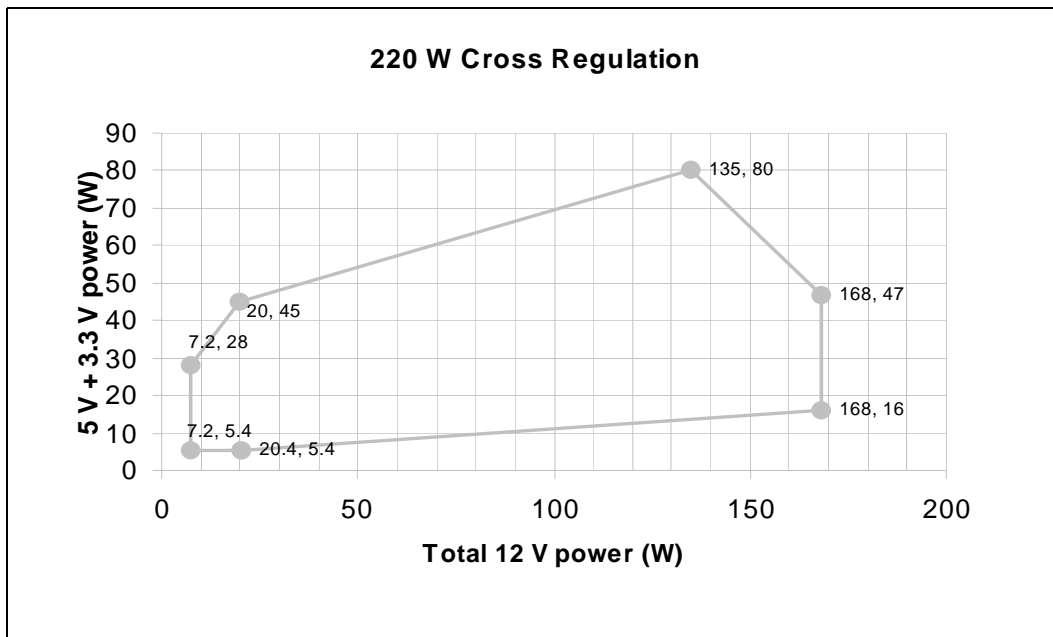

Table 62. Typical Power Distribution for 220 W Configurations

Output	Minimum Current (A)	Rated Current (A)	Peak Current (A)
+12 VDC ¹	0.6	14.0	16.0
+5 VDC ²	0.2	14.0	-
+3.3 VDC	0.1	13.0	-
-12 VDC	0	0.3	-
+5 VSB ¹	0	2.0	2.5

NOTES:

1. Peak currents may last up to 17 seconds with not more than one occurrence per minute.
2. Total combined output of 3.3 V and 5 V is ≤ 80 W.



Figure 32. Cross Loading Graph for 270 W Configuration

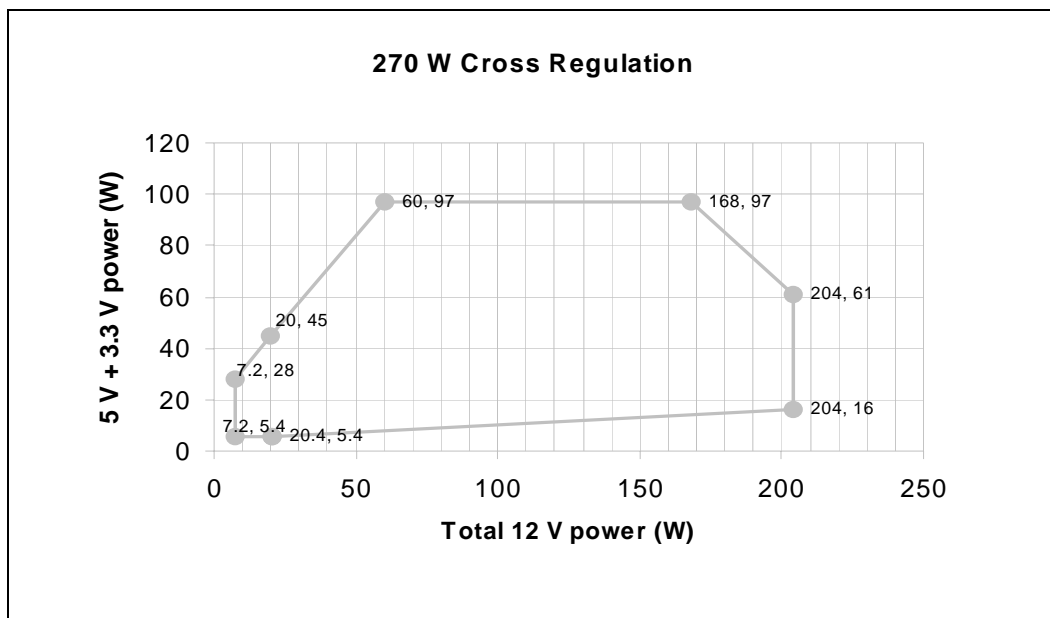

Table 63. Typical Power Distribution for 270 W Configurations

Output	Minimum Current (A)	Rated Current (A)	Peak Current (A)
+12 VDC ¹	0.6	17 A	18 A
+5 VDC ²	0.2	15.0	-
+3.3 VDC	0.1	19.0	-
-12 VDC	0	0.3	-
+5 VSB ¹	0	2.0	2.5

NOTES:

1. Peak currents may last up to 17 seconds with not more than one occurrence per minute.
2. Total combined output of 3.3 V and 5 V is ≤ 97 W.

Figure 33. Cross Loading Graph for 300 W Configuration

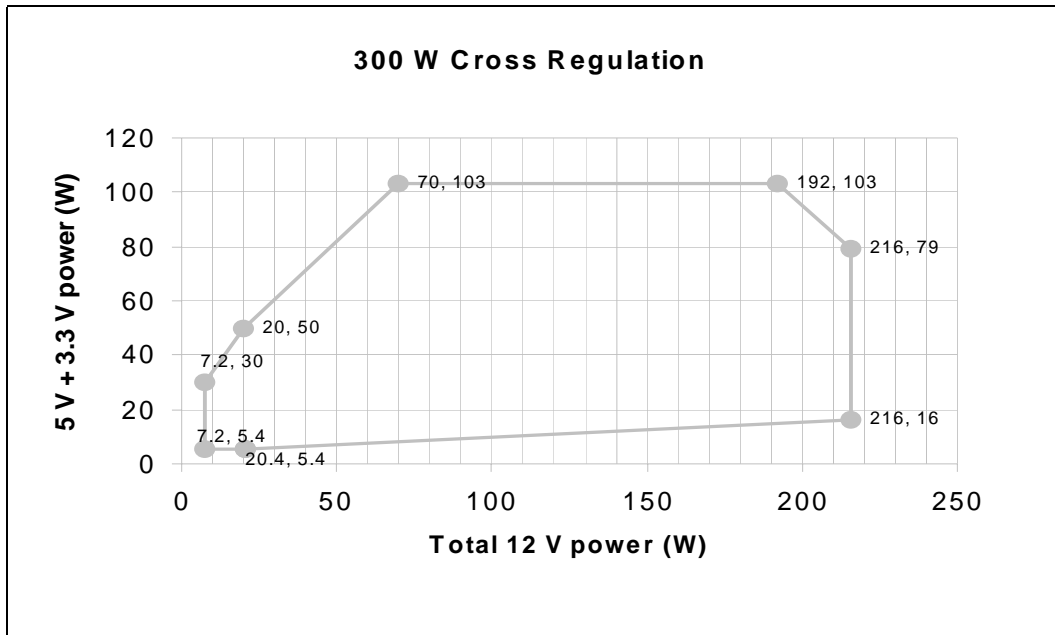

Table 64. Typical Power Distribution for 300 W Configurations

Output	Minimum Current (A)	Rated Current (A)	Peak Current (A)
+12 V1DC	0.1	11.0	-
+12 V2DC ¹	0.5	8.0	13.0
+5 VDC ²	0.2	15.0	-
+3.3 VDC	0.1	21.0	-
-12 VDC	0	0.3	-
+5 VSB ³	0	2.0	2.5

NOTES:

- 12V2 supports processor power requirements and must have a separate current limit and provide 19 A peak current lasting for 10 ms. The minimum voltage during peak is > 10.8 VDC.
- Total combined output of 3.3 V and 5 V is ≤ 103 W.
- Peak currents may last up to 17 seconds with not more than one occurrence per minute.

Table 65. 180 W Loading for Efficiency Measurements¹

Loading	+12 V	+5 V	+3.3 V	-12 V	+5 VSB
Full (A)	8.4	8.4	7.8	0.3	1.7
Typical (A)	4.2	4.2	3.9	0.1	0.8
Light (A)	1.7	1.7	1.6	0.1	0.3

NOTES:

- Loading calculated by method available at <http://www.efficientpowersupplies.org>.

Table 66. 220 W Loading for Efficiency Measurements¹

Loading	+12 V	+5 V	+3.3 V	-12 V	+5 VSB
Full (A)	11.8	8.3	7.7	0.3	1.7
Typical (A)	5.9	4.2	3.9	0.1	0.8
Light (A)	2.4	1.7	1.5	0.1	0.3

NOTES:

1. Loading calculated by method available at <http://www.efficientpowersupplies.org>.

Table 67. 270 W Loading for Efficiency Measurements¹

Loading	+12 V	+5 V	+3.3 V	-12 V	+5 VSB
Full (A)	14.6	9.1	11.5	0.3	1.7
Typical (A)	7.3	4.5	5.7	0.1	0.9
Light (A)	2.9	1.8	2.3	0.1	0.3

NOTES:

1. Loading calculated by method available at <http://www.efficientpowersupplies.org>.

Table 68. 300 W Loading for Efficiency Measurements¹

Loading	+12 V1	+12 V2	+5 V	+3.3 V	-12 V	+5 VSB
Full (A)	9.6	7.0	9.3	13.0	0.3	1.7
Typical (A)	4.8	3.5	4.7	6.5	0.1	0.9
Light (A)	1.9	1.4	1.9	2.6	0.1	0.3

NOTES:

1. Loading calculated by method available at <http://www.efficientpowersupplies.org>.

13.2 Lower Profile Package - Physical Dimensions - REQUIRED

The power supply shall be enclosed and meet the physical outline shown in [Figure 34](#).

13.3 Fan Requirements - REQUIRED

The fan will draw air from the computer system cavity pressurizing the power supply enclosure. The power supply enclosure shall exhaust the air through a grill located on the rear panel. See [Figure 35](#). The movement of the fan to the computer system cavity is to help limit the acoustic noise of the unit.

The fan will be 40 mm.

Figure 34. 40 mm Profile Mechanical Outline

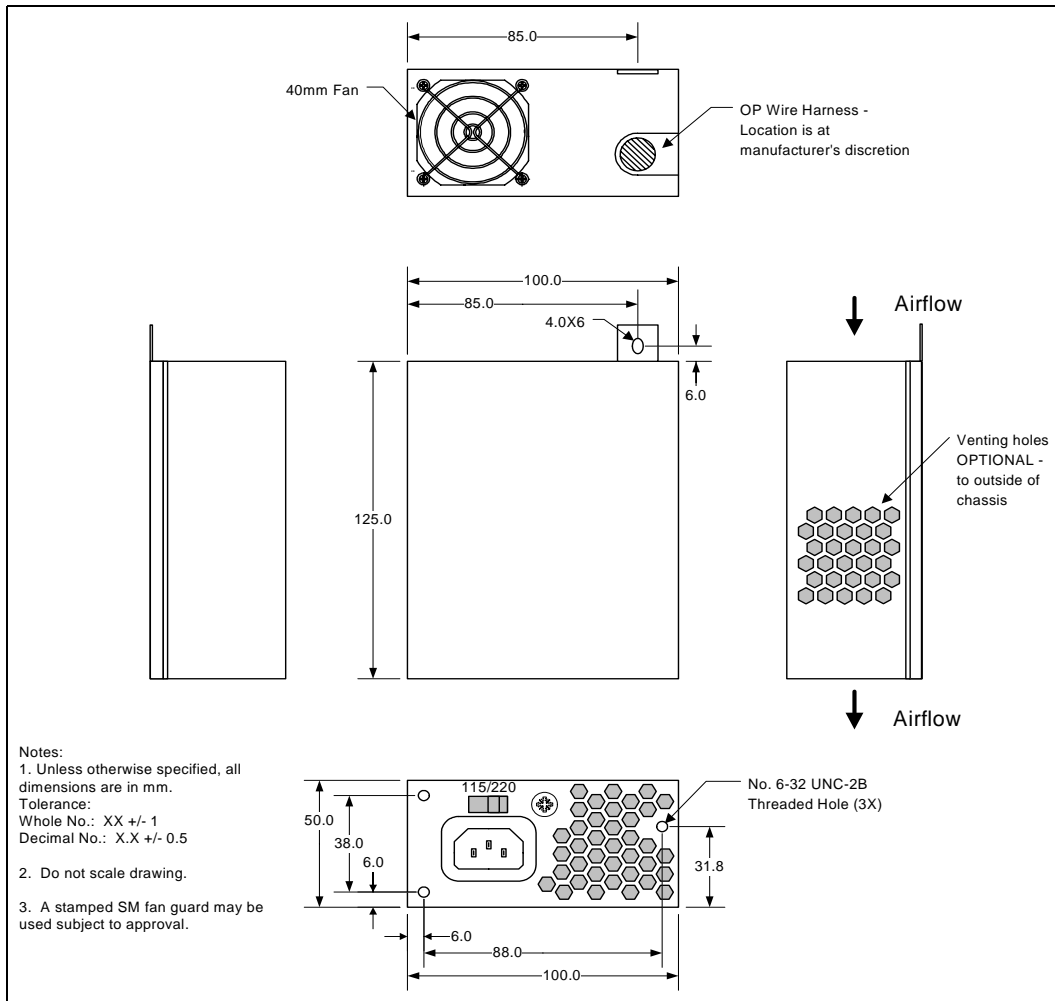
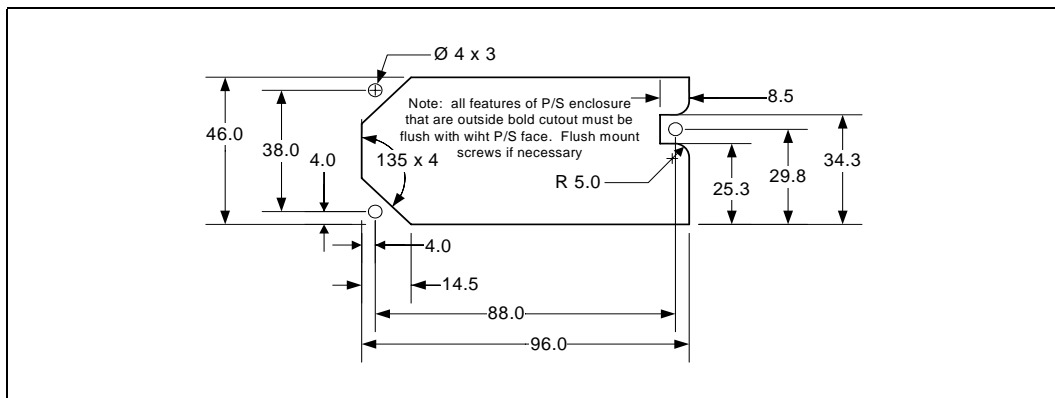

Figure 35. Chassis Cutout





13.4 Top Fan Mount Package - Physical Dimensions - REQUIRED

The power supply shall be enclosed and meet the physical outline shown in [Figure 36](#).

13.5 Fan Requirements - REQUIRED

The fan will draw air from the computer system cavity pressurizing the power supply enclosure. The power supply enclosure shall exhaust the air through a grill located on the rear panel. See [Figure 37](#). Moving the fan to the computer system cavity helps to limit the acoustic noise of the unit.

The fan will be 80mm.

To prevent damage to the fan during shipment and handling, the power supply designer should consider recessing the fan mounting, as shown in [Figure 38](#).

Figure 36. Top Mount Fan Profile Mechanical Outline

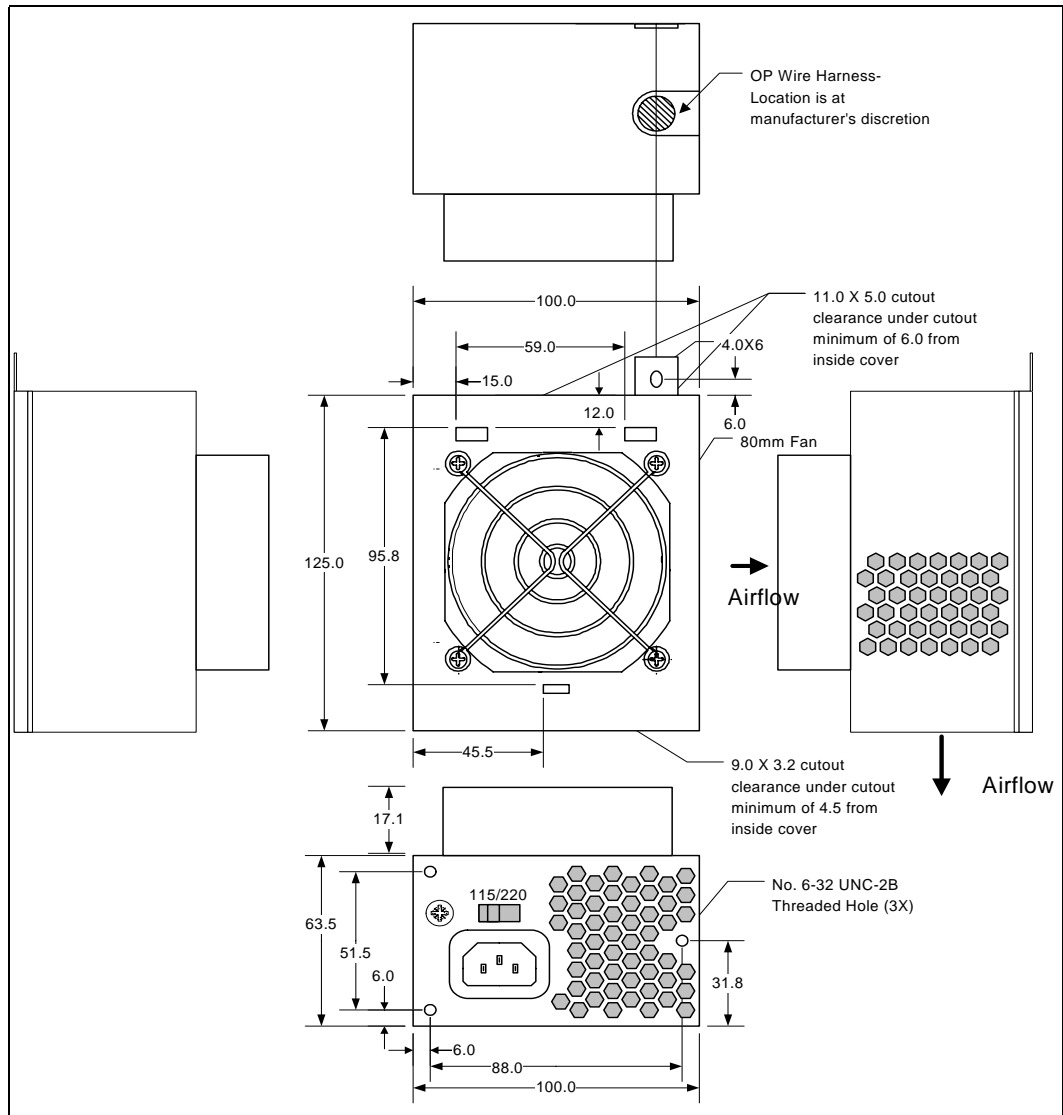



Figure 37. Chassis Cutout

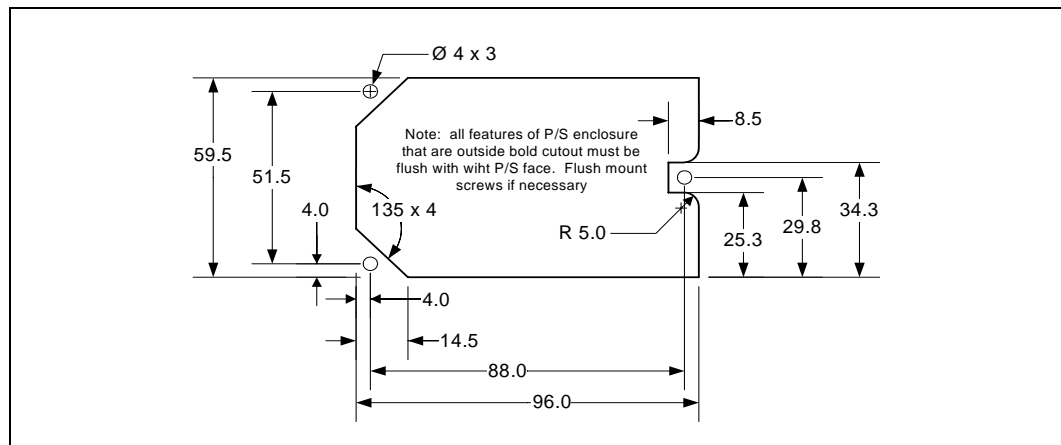
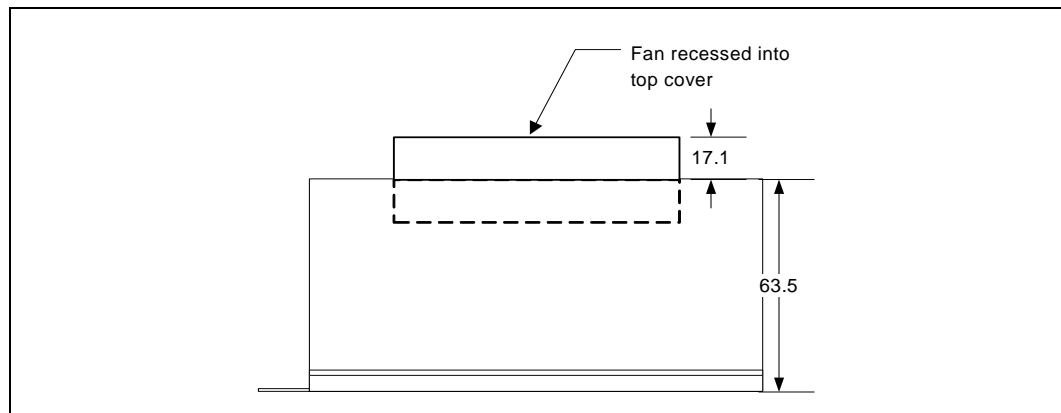

Figure 38. Recessed Fan Mounting



13.6 Reduced Depth Top Mount Fan - Physical Dimensions - REQUIRED

The power supply shall be enclosed and meet the physical outline shown in [Figure 39](#).

13.7 Fan Requirements - REQUIRED

The fan will draw air from the computer system cavity pressurizing the power supply enclosure. The power supply enclosure shall exhaust the air through a grill located on the rear panel. See [Figure 40](#). Moving the fan to the computer system cavity helps to limit the acoustic noise of the unit.

The fan will be 80 mm.

Figure 39. Reduced Depth Top Mount Fan Profile Mechanical Outline

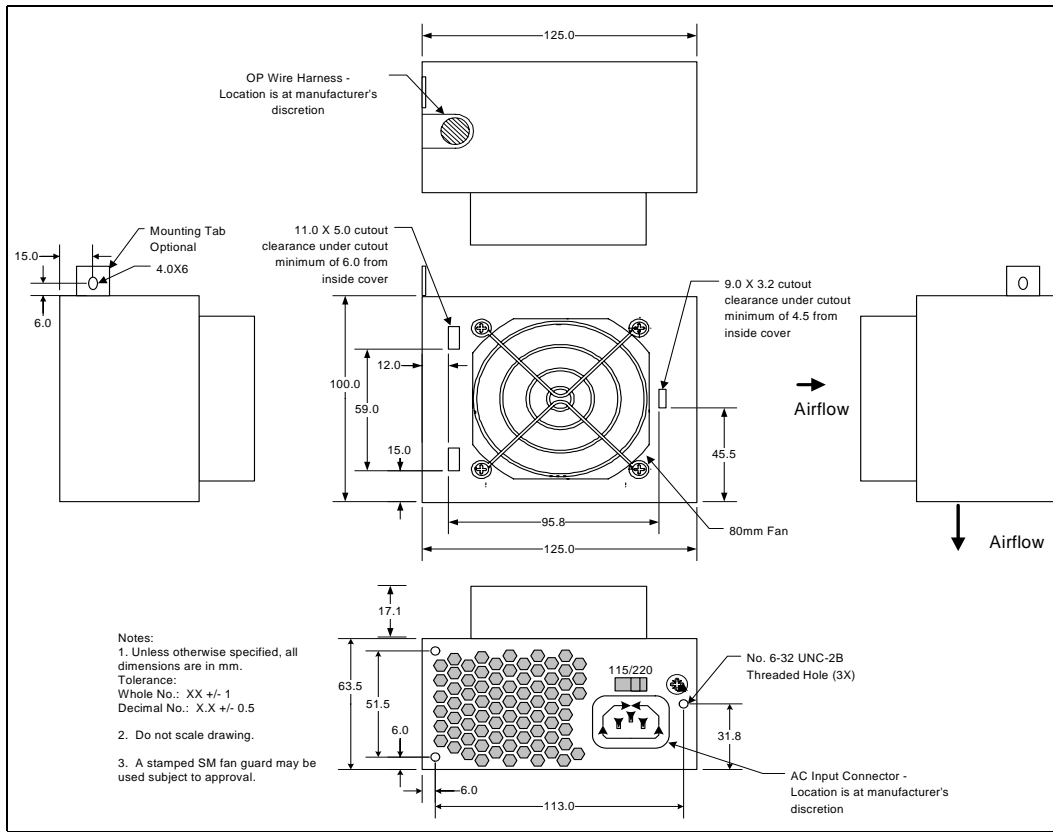
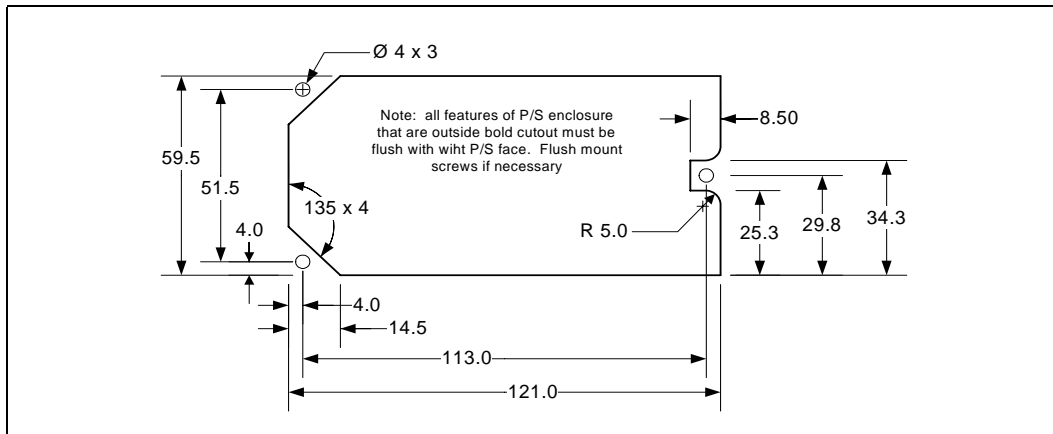

Figure 40. Chassis Cutout



13.8 Standard SFX Profile Package - Physical Dimensions - REQUIRED

The power supply shall be enclosed and meet the physical outline shown in [Figure 41](#).



13.9 Fan Requirements - REQUIRED

The fan will draw air from the computer system cavity pressurizing the power supply enclosure. The power supply enclosure shall exhaust the air through a grill located on the rear panel. See Figure 42. The movement of the fan to the computer system cavity is to help limit the acoustic noise of the unit.

The fan will be 60 mm.

Figure 41. 60 mm Mechanical Outline

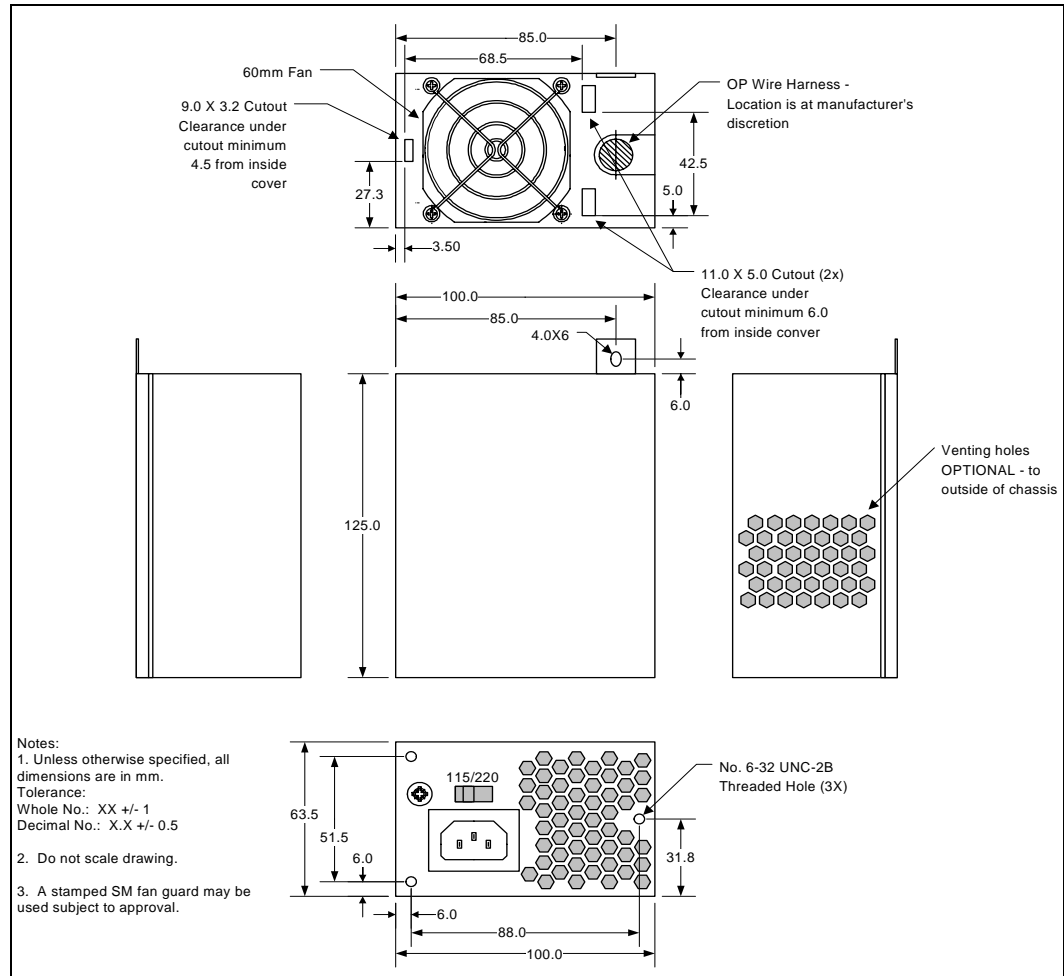
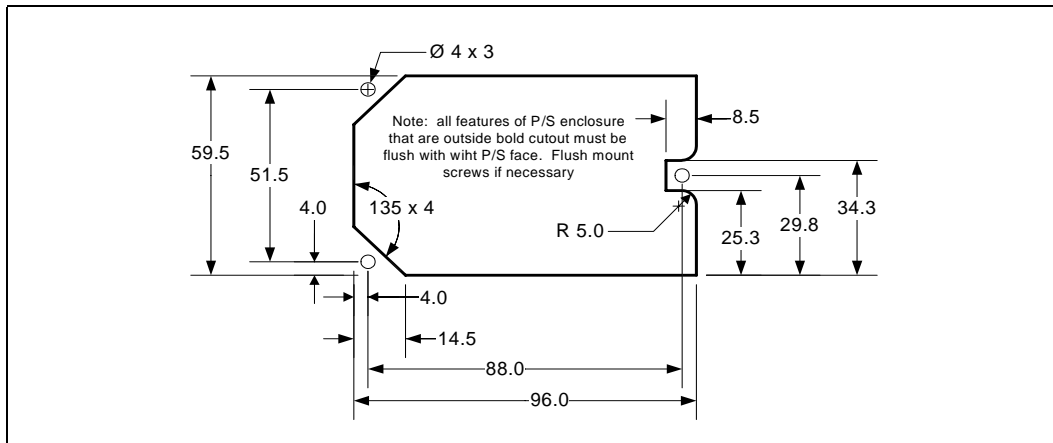

Figure 42. Chassis Cutout



13.10 PS3 Form Factor- Physical Dimensions - REQUIRED

The power supply shall be enclosed and meet the physical outline shown in [Figure 43](#).

13.11 Fan Requirements - REQUIRED

An 80 mm axial fan is typically needed to provide enough cooling airflow through a high performance Micro ATX system. Exact CFM requirements vary by application and end-use environment, but 25-35 CFM is typical for the fan itself.

For consumer or other noise-sensitive applications, it is recommended that a thermally sensitive fan speed control circuit be used to balance system-level thermal and acoustic performance. The circuit typically senses the temperature of an internal heatsink and/or incoming ambient air and adjusts the fan speed as necessary to keep power supply and system component temperatures within specification. Both the power supply and system designers should be aware of the dependencies of the power supply and system temperatures on the control circuit response curve and fan size and should specify them very carefully.

The power supply fan should be turned off when PS_ON# is de-asserted (high). In this state, any remaining active power supply circuitry must rely only on passive convection for cooling.

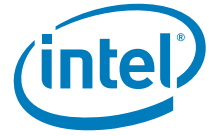
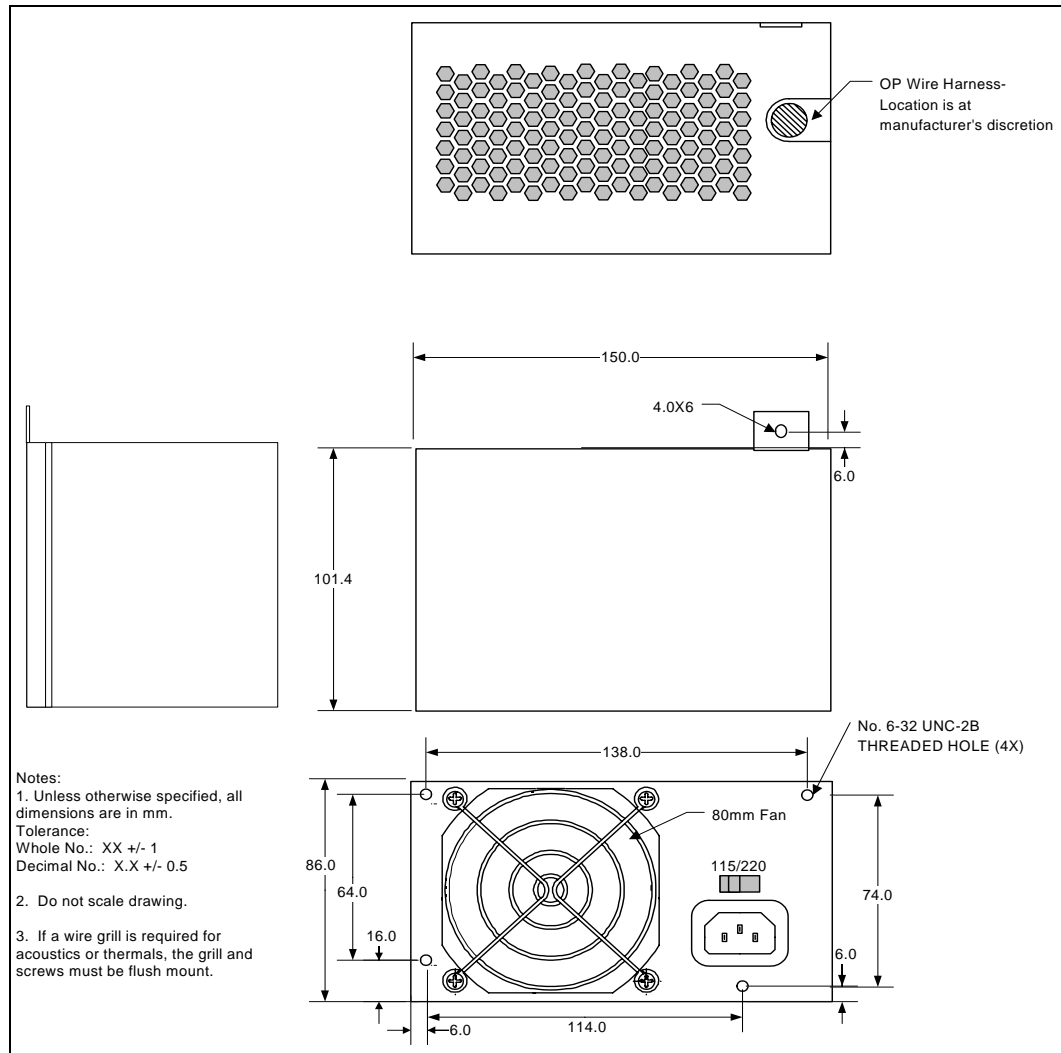

Figure 43. PS3 Mechanical Outline



§





14 TFX12V Specific Guidelines 2.31

For Thin Form Factor with 12-volt connector power supplies.

14.1 Typical Power Distribution - RECOMMENDED

DC output power requirements and distributions will vary based on specific system options and implementation.

Significant dependencies include the quantity and types of processors, memory, add-in card slots, and peripheral bays, as well as support for advanced graphics or other features. Figure 44 through Figure 47 shows the power distribution and cross loading tables for power supplies in the range of 180 W to 300 W. These are recommendations but it is ultimately the responsibility of the designer to define a power budget for a given target product and market.

Figure 44. Cross Loading Graph for 180 W Configuration

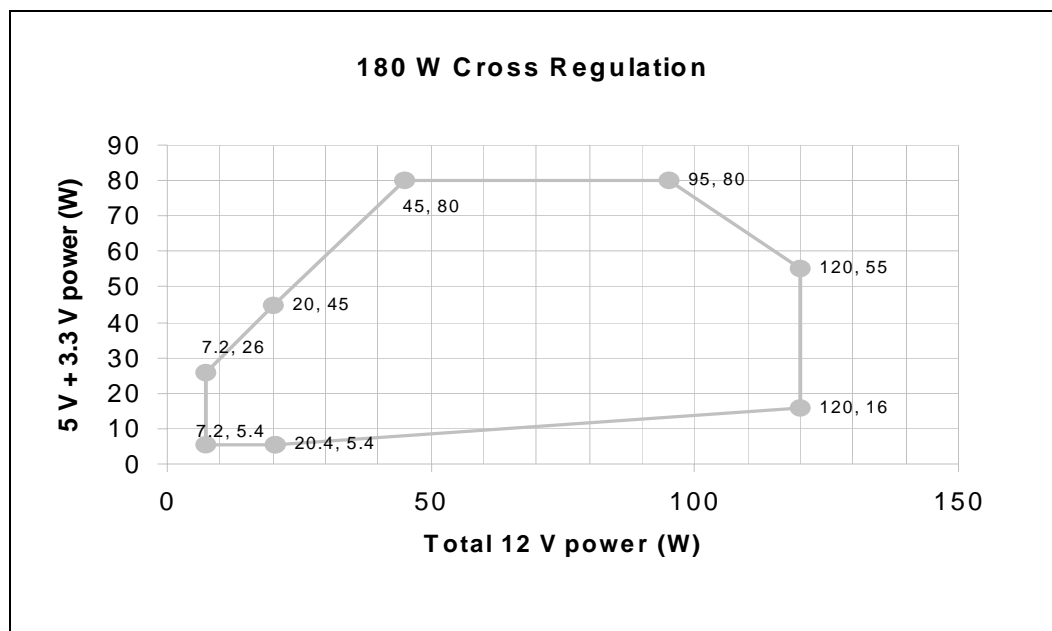

Table 69. Typical Power Distribution for 180 W Configurations

Output	Minimum Current (A)	Rated Current (A)	Peak Current (A)
+12 VDC ¹	0.6	10.0	13.0
+5 VDC ²	0.2	14.0	-



Table 69. Typical Power Distribution for 180 W Configurations

Output	Minimum Current (A)	Rated Current (A)	Peak Current (A)
+3.3 VDC	0.1	13.0	-
-12 VDC	0	0.3	-
+5 VSB ¹	0	2.0	2.5

NOTES:

1. Peak currents may last up to 17 seconds with not more than one occurrence per minute.
2. Total combined output of 3.3 V and 5 V is ≤ 80 W.

Figure 45. Cross Loading Graph for 220 W Configurations

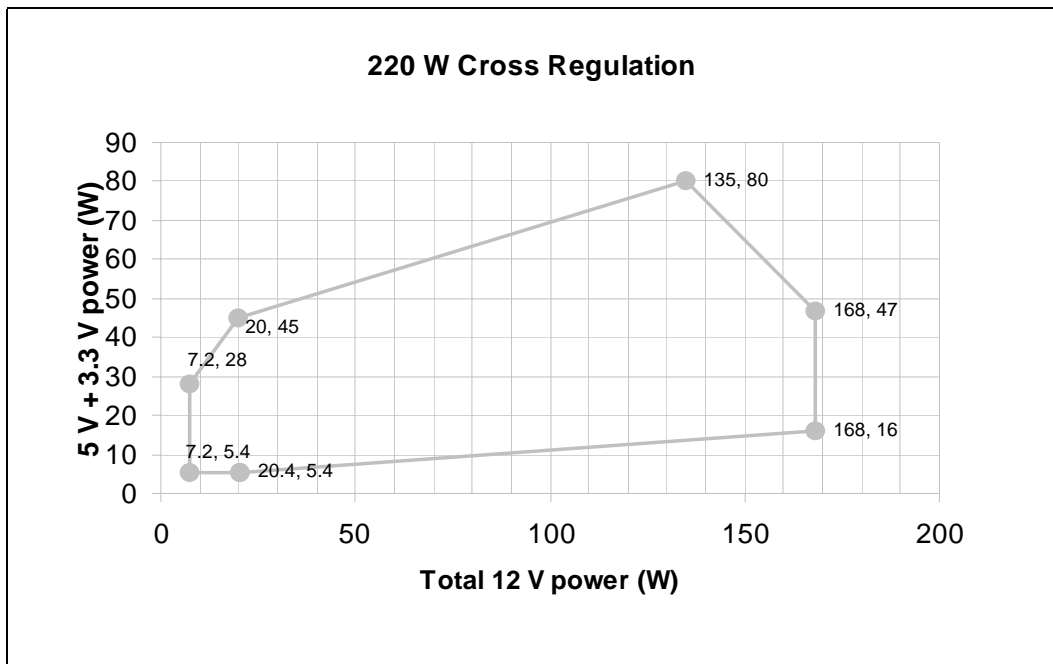

Table 70. Typical Power Distribution for 220 W Configurations

Output	Minimum Current (A)	Rated Current (A)	Peak Current (A)
+12 VDC ¹	0.6	14.0	16.0
+5 VDC ²	0.2	14.0	-
+3.3 VDC	0.1	13.0	-
-12 VDC	0	0.3	-
+5 VSB ¹	0	2.0	2.5

NOTES:

1. Peak currents may last up to 17 seconds with not more than one occurrence per minute.
2. Total combined output of 3.3 V and 5 V is ≤ 80 W.



Figure 46. Cross Loading Graph for 270 W Configuration

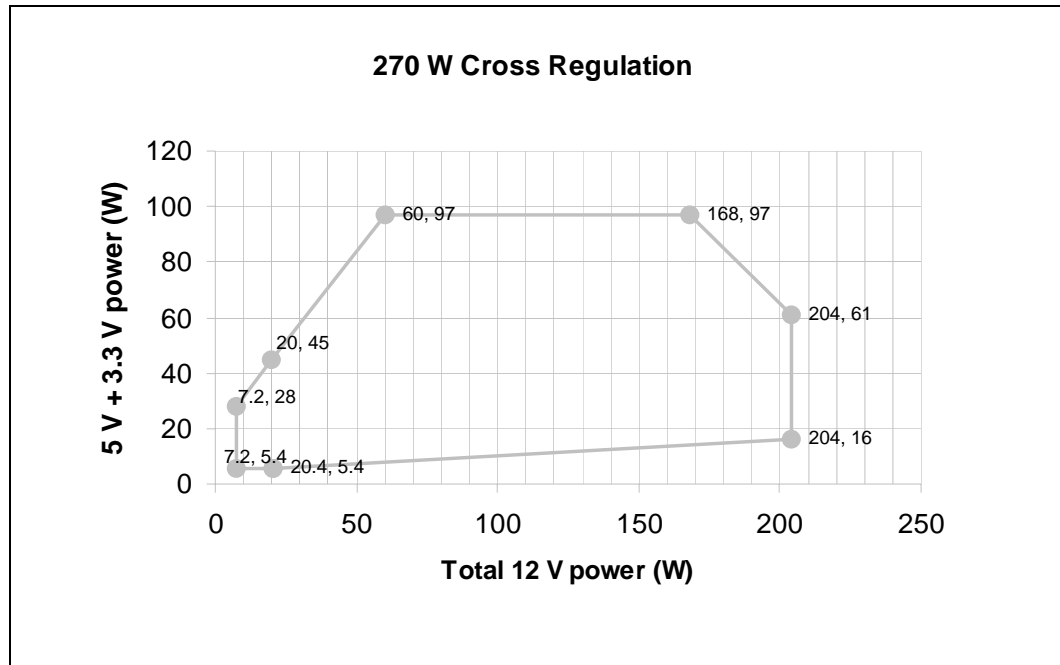

Table 71. Typical Power Distribution for 270 W Configurations

Output	Minimum Current (A)	Rated Current (A)	Peak Current (A)
+12 VDC ¹	0.6	17 A	18 A
+5 VDC ²	0.2	15.0	-
+3.3 VDC	0.1	19.0	-
-12 VDC	0	0.3	-
+5 VSB ¹	0	2.0	2.5

- NOTES:**
1. Peak currents may last up to 17 seconds with not more than one occurrence per minute.
 2. Total combined output of 3.3 V and 5 V is ≤ 97 W.

Figure 47. Cross Loading Graph for 300 W Configuration

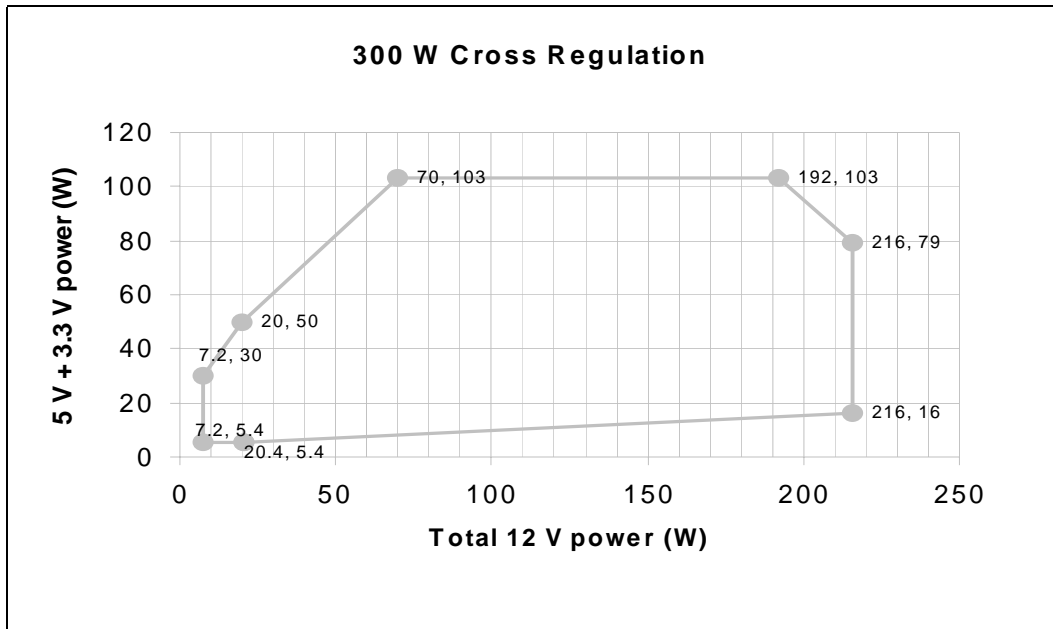

Table 72. Typical Power Distribution for 300 W Configurations

Output	Minimum Current (A)	Rated Current (A)	Peak Current (A)
+12 V1DC	0.1	11.0	-
+12 V2DC ¹	0.5	8.0	13.0
+5 VDC ²	0.2	15.0	-
+3.3 VDC	0.1	21.0	-
-12 VDC	0	0.3	-
+5 VSB ³	0	2.0	2.5

NOTES:

- 12V2 supports processor power requirements and must have a separate current limit and provide 19 A peak current lasting for 10 ms. The minimum voltage during peak is > 10.8 VDC.
- Total combined output of 3.3 V and 5 V is ≤ 103 W.
- Peak currents may last up to 17 seconds with not more than one occurrence per minute.

Table 73. 180 W Loading for Efficiency Measurements¹

Loading	+12 V	+5 V	+3.3 V	-12 V	+5 VSB
Full (A)	8.4	8.4	7.8	0.3	1.7
Typical (A)	4.2	4.2	3.9	0.1	0.8
Light (A)	1.7	1.7	1.6	0.1	0.3

NOTES:

- Loading calculated by method available at <http://www.efficientpowersupplies.org>.

Table 74. 220 W Loading for Efficiency Measurements¹

Loading	+12 V	+5 V	+3.3 V	-12 V	+5 VSB
Full (A)	11.8	8.3	7.7	0.3	1.7
Typical (A)	5.9	4.2	3.9	0.1	0.8
Light (A)	2.4	1.7	1.5	0.1	0.3

NOTES:

1. Loading calculated by method available at <http://www.efficientpowersupplies.org>.

Table 75. 270 W Loading for Efficiency Measurements¹

Loading	+12 V	+5 V	+3.3 V	-12 V	+5 VSB
Full (A)	14.6	9.1	11.5	0.3	1.7
Typical (A)	7.3	4.5	5.7	0.1	0.9
Light (A)	2.9	1.8	2.3	0.1	0.3

NOTES:

1. Loading calculated by method available at <http://www.efficientpowersupplies.org>.

Table 76. 300 W Loading for Efficiency Measurements¹

Loading	+12 V1	+12 V2	+5 V	+3.3 V	-12 V	+5 VSB
Full (A)	9.6	7.0	9.3	13.0	0.3	1.7
Typical (A)	4.8	3.5	4.7	6.5	0.1	0.9
Light (A)	1.9	1.4	1.9	2.6	0.1	0.3

NOTES:

1. Loading calculated by method available at <http://www.efficientpowersupplies.org>.

14.2 Physical Dimensions - REQUIRED

Figure 48. Mechanical Outline

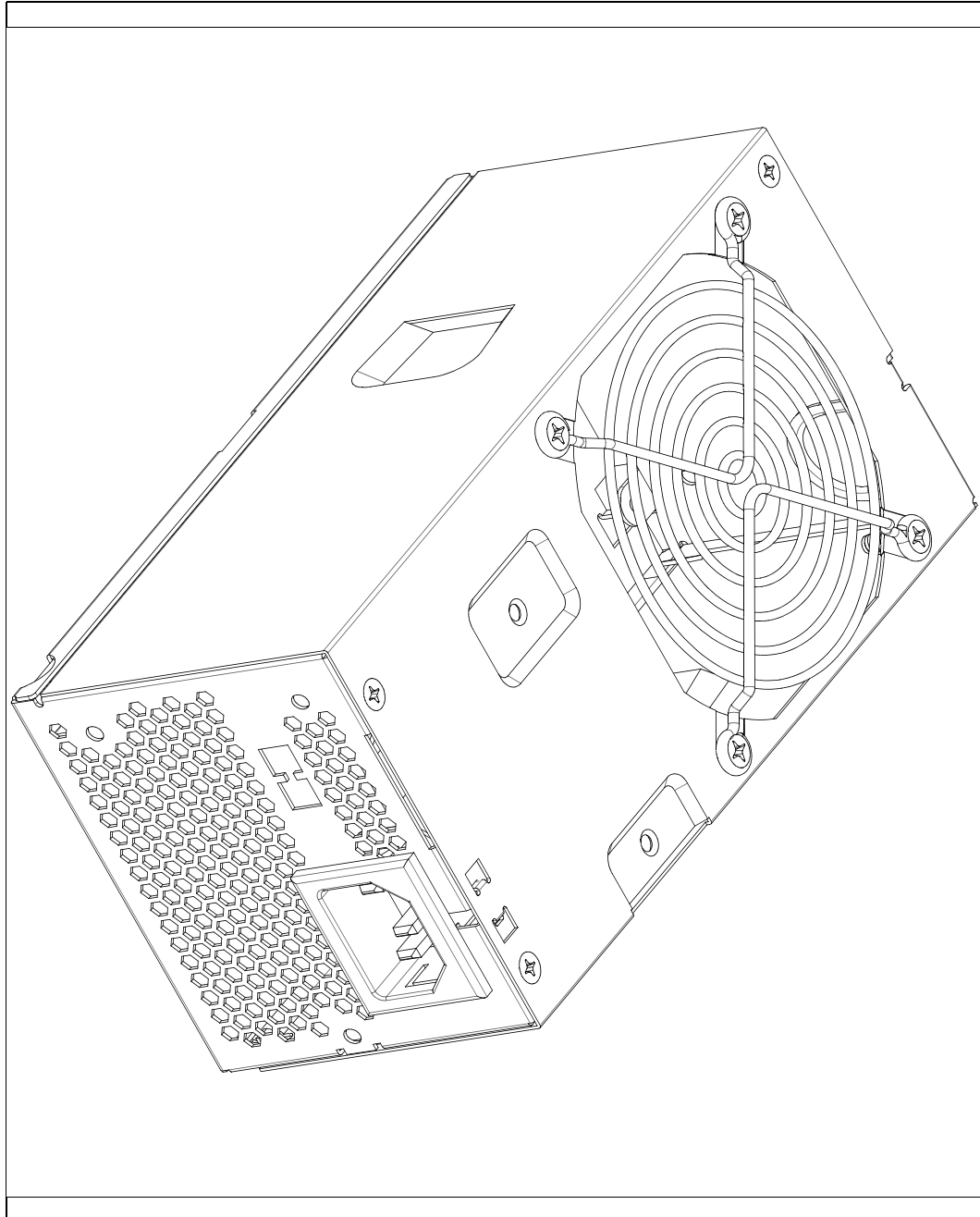



Figure 49. Dimensions & Recommended Feature Placements (not to scale)

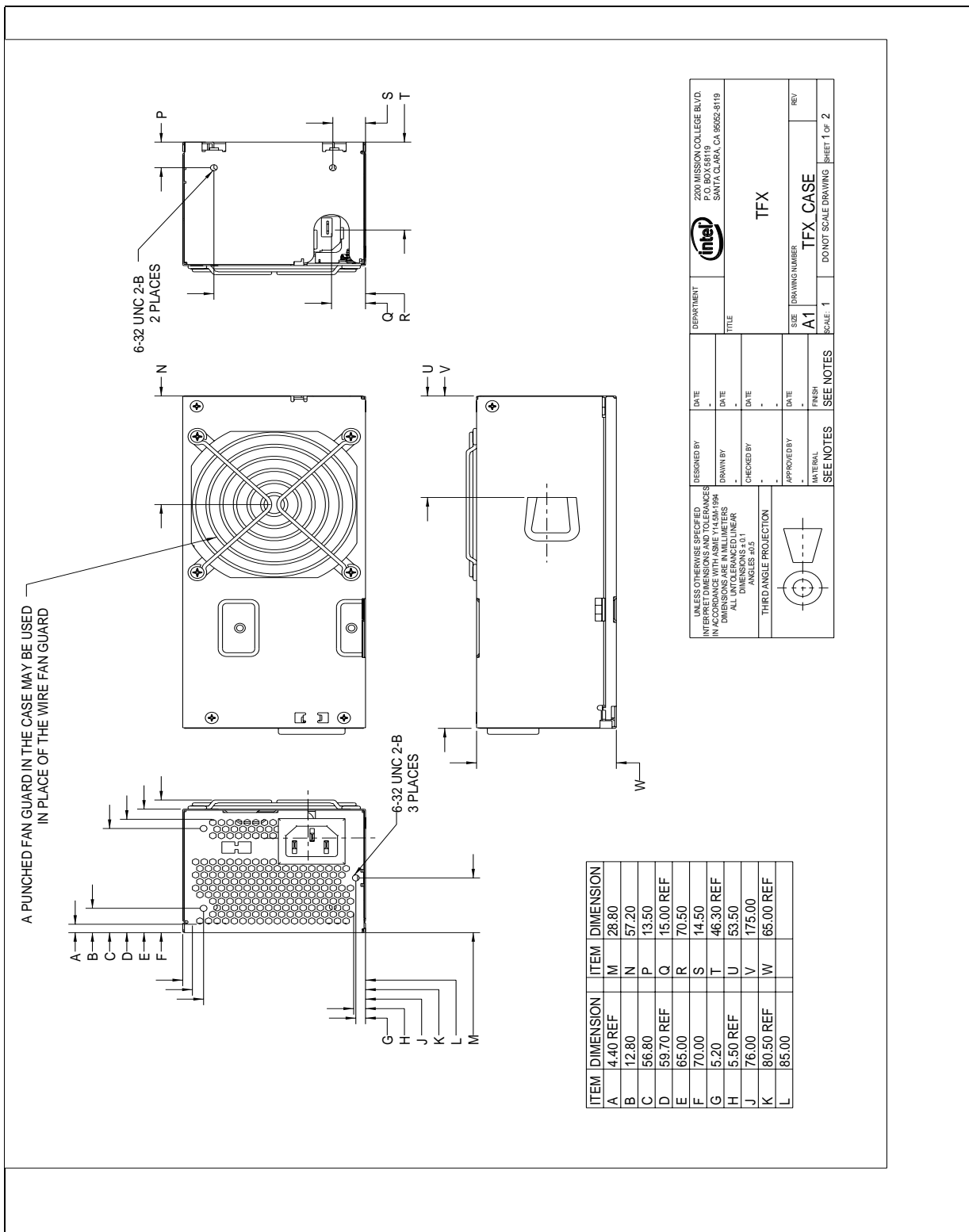
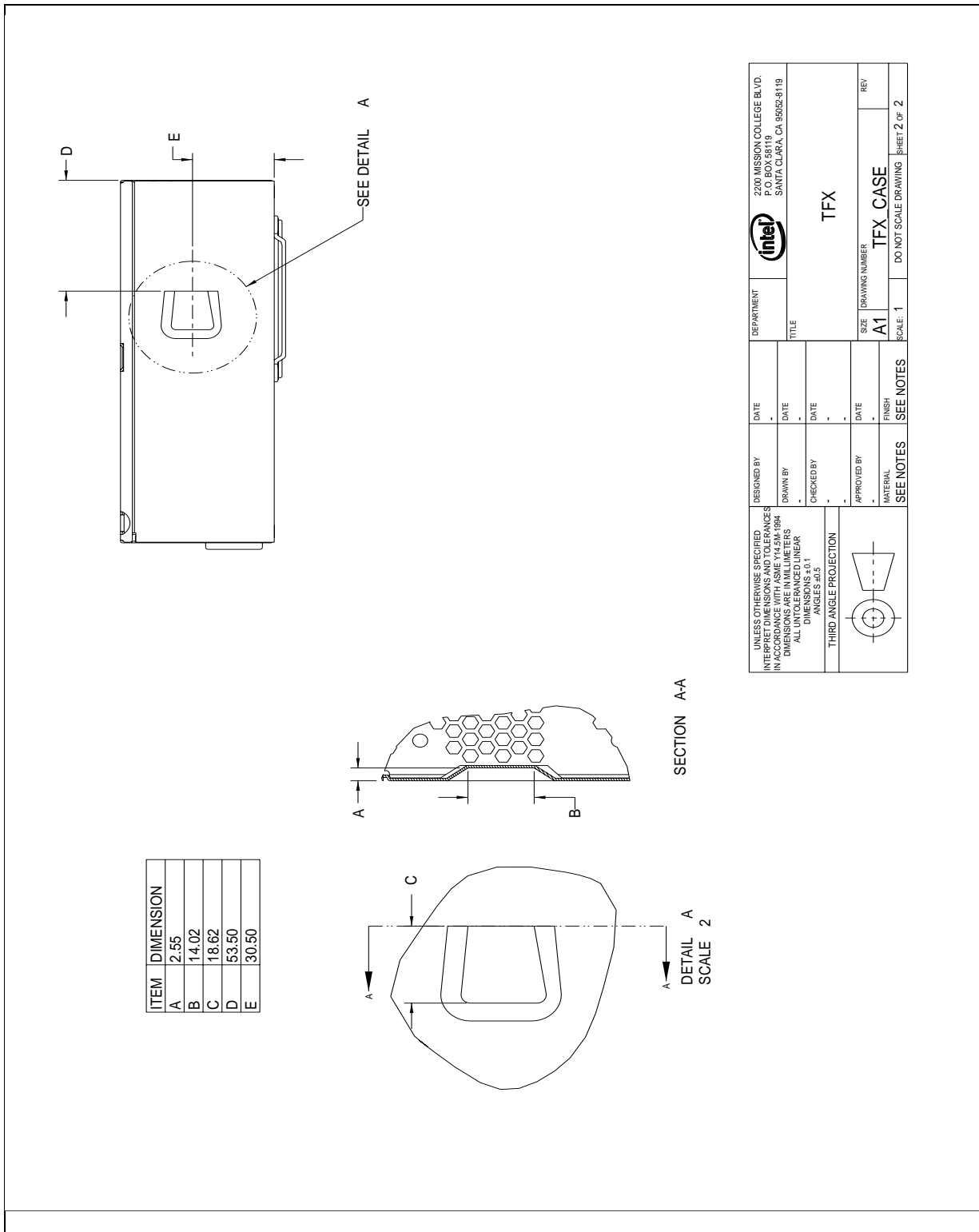

Figure 50. Power Supply Mounting Slot Detail



UNLESS OTHERWISE SPECIFIED INTERPRET DIMENSIONS AND TOLERANCES IN ACCORDANCE WITH ASME Y14.5M-1994 DIMENSIONS ARE IN MILLIMETERS DIMENSIONS IN PARENTHESES ARE IN INCHES ANGLES ±0.1	DESIGNED BY	DATE	DEPARTMENT	2200 MISSION COLLEGE BLVD. P.O. BOX 58119 SANTA CLARA, CA 95052-8119
	DRAWN BY	DATE	TITLE	TFX
THIRD ANGLE PROJECTION	CHECKED BY	DATE	SIZE	DRAWING NUMBER
	APPROVED BY	DATE	A1	TFX CASE
	MATERIAL	FINISH	SCALE: 1	DO NOT SCALE DRAWING
	SEE NOTES	SEE NOTES	SCALE: 2	SHEET 2 OF 2



14.3 Mounting Options - RECOMMENDED

The TFX12V mechanical design provides two options for mounting in a system chassis. The unit can be mounted using one of the mounting holes on the front end (non-vented end) or a chassis feature can be designed to engage the slot provided in the bottom of the supply. In order to accommodate different system chassis layouts, the TFX12V power supply is also designed to mount in two orientations (fan left and fan right) as shown in Figure 51. A mounting hole and slot should be provided for each orientation as shown in Figure 49. Details of a suggested geometry for the mounting slot are shown in Figure 50.

Figure 51. Fan Right and Fan Left Orientations of Power Supply in a Chassis

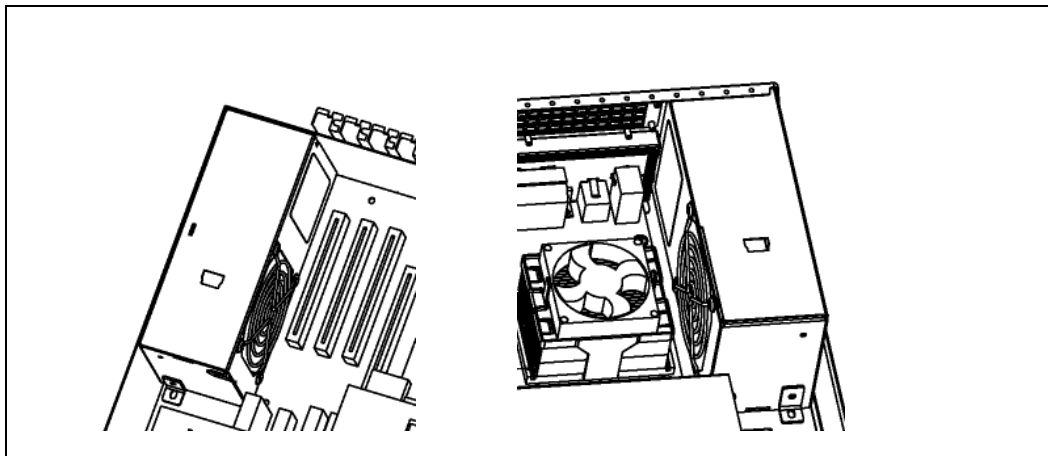

14.4 Chassis Requirements - RECOMMENDED

To ensure the power supply can be easily integrated, the following features should be designed into a chassis intended to use a TFX12V power supply:

- Chassis cutout (normally in the rear panel of the chassis) as shown in Figure 52.
- EITHER a mounting bracket to interface with the forward mounting hole on the power supply OR a mounting tab as shown in Figure 53 to interface with the mounting slot on the bottom of the power supply.

Figure 52. Suggested TFX12V Chassis Cutout

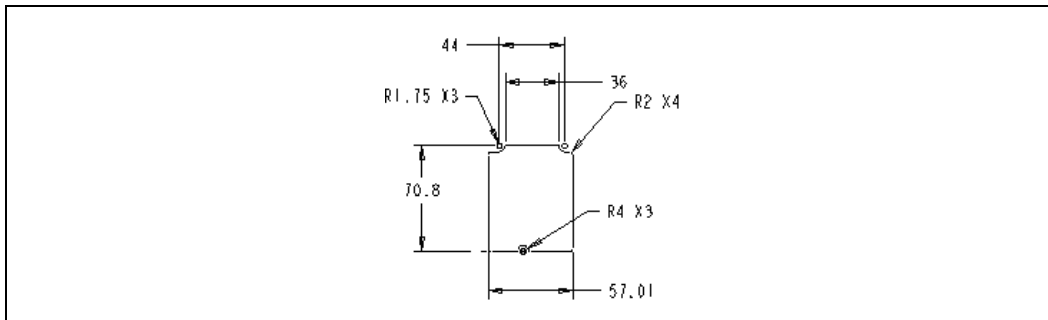
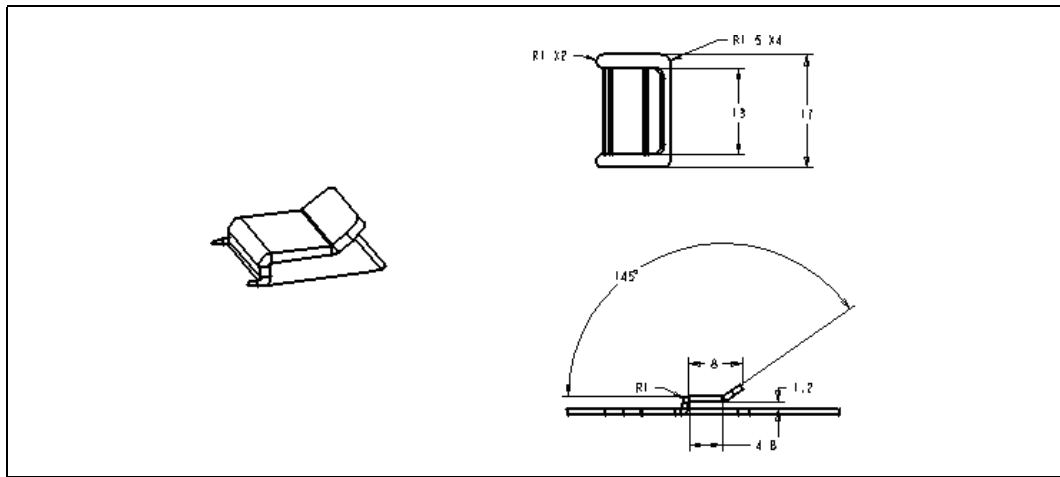

Figure 53. Suggested Mounting Tab (chassis feature)





15 Flex ATX Specific Guidelines 1.01

For Flex ATX Form Factor with 12-volt connector power supplies.

15.1 Typical Power Distribution - RECOMMENDED

DC output power requirements and distributions will vary based on specific system options and implementation.

Significant dependencies include the quantity and types of processors, memory, add-in card slots, and peripheral bays, as well as support for advanced graphics or other features. Figure 54 through Figure 56 shows the power distribution and cross loading tables for power supplies in the range of 180 W to 270 W. These are recommendations but it is ultimately the responsibility of the designer to define a power budget for a given target product and market.

Figure 54. Cross Loading Graph for 180 W Configuration

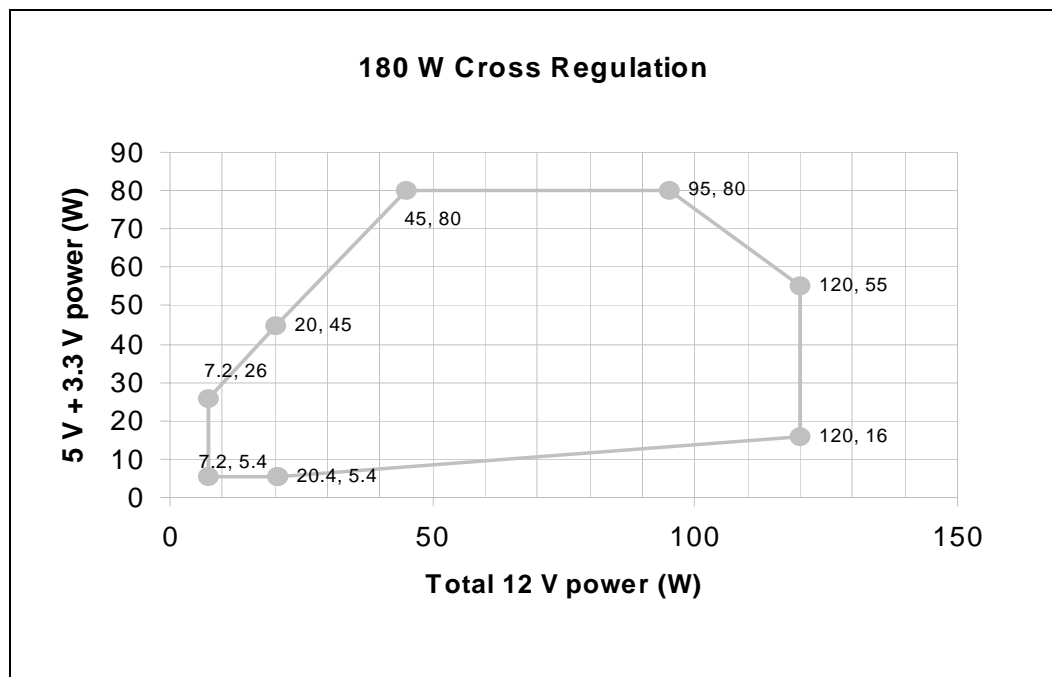

Table 77. Typical Power Distribution for 180 W Configurations

Output	Minimum Current (A)	Rated Current (A)	Peak Current (A)
+12 VDC ¹	0.6	10.0	13.0
+5 VDC ²	0.2	14.0	-
+3.3 VDC	0.1	13.0	-
-12 VDC	0	0.3	-
+5 VSB ¹	0	2.0	2.5

NOTES:

1. Peak currents may last up to 17 seconds with not more than one occurrence per minute.
2. Total combined output of 3.3 V and 5 V is ≤ 80 W.

Figure 55. Cross Loading Graph for 220 W Configurations

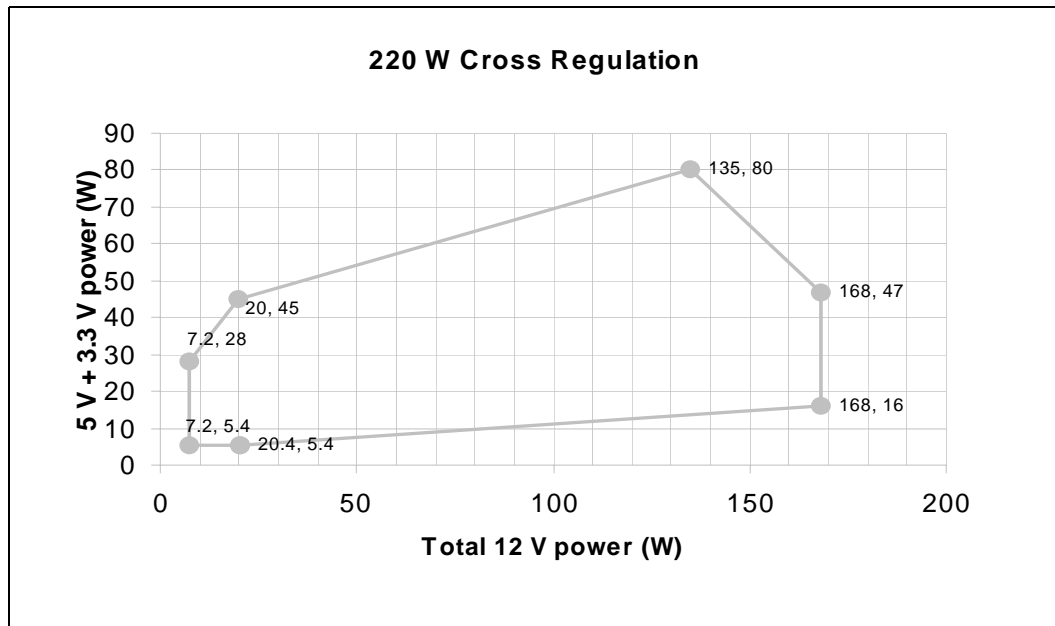

Table 78. Typical Power Distribution for 220 W Configurations

Output	Minimum Current (A)	Rated Current (A)	Peak Current (A)
+12 VDC ¹	0.6	14.0	16.0
+5 VDC ²	0.2	14.0	-
+3.3 VDC	0.1	13.0	-
-12 VDC	0	0.3	-
+5 VSB ¹	0	2.0	2.5

NOTES:

1. Peak currents may last up to 17 seconds with not more than one occurrence per minute.
2. Total combined output of 3.3 V and 5 V is ≤ 80 W.



Figure 56. Cross Loading Graph for 270 W Configuration

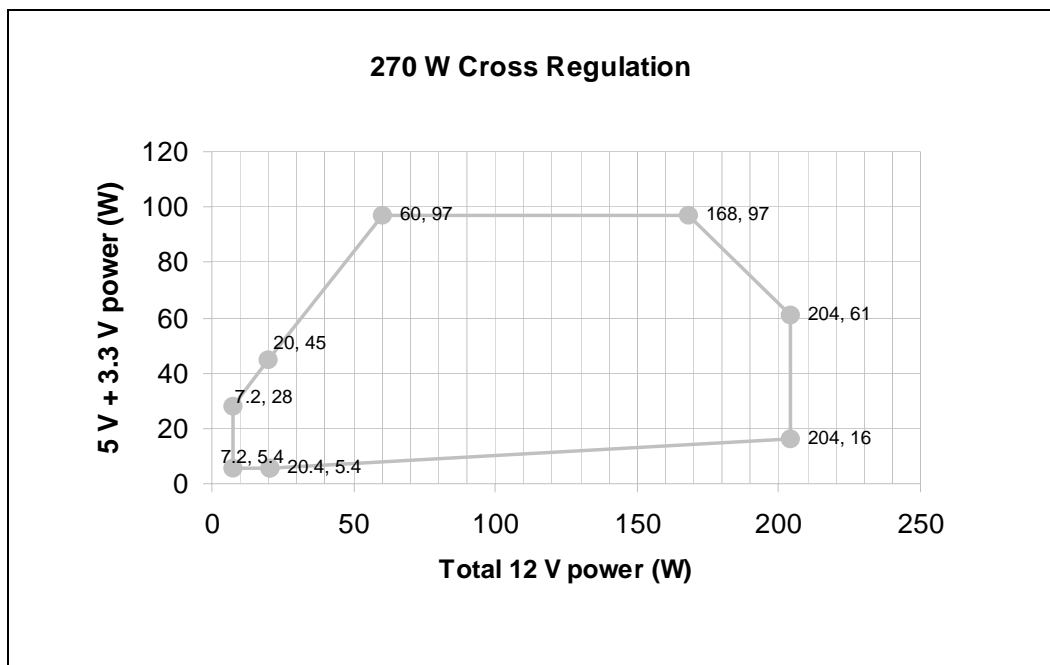

Table 79. Typical Power Distribution for 270 W Configurations

Output	Minimum Current (A)	Rated Current (A)	Peak Current (A)
+12 VDC ¹	0.6	17 A	18 A
+5 VDC ²	0.2	15.0	-
+3.3 VDC	0.1	19.0	-
-12 VDC	0	0.3	-
+5 VSB ¹	0	2.0	2.5

NOTES:
 1. Peak currents may last up to 17 seconds with not more than one occurrence per minute.
 2. Total combined output of 3.3 V and 5 V is ≤ 97 W.

Table 80. 180 W Loading for Efficiency Measurements¹

Loading	+12 V	+5 V	+3.3 V	-12 V	+5 VSB
Full (A)	8.4	8.4	7.8	0.3	1.7
Typical (A)	4.2	4.2	3.9	0.1	0.8
Light (A)	1.7	1.7	1.6	0.1	0.3

NOTES:
 1. Loading calculated by method available at <http://www.efficientpowersupplies.org>.



Table 81. 220 W Loading for Efficiency Measurements¹

Loading	+12 V	+5 V	+3.3 V	-12 V	+5 VSB
Full (A)	11.8	8.3	7.7	0.3	1.7
Typical (A)	5.9	4.2	3.9	0.1	0.8
Light (A)	2.4	1.7	1.5	0.1	0.3

NOTES:

1. Loading calculated by method available at <http://www.efficientpowersupplies.org>.

Table 82. 270 W Loading for Efficiency Measurements¹

Loading	+12 V	+5 V	+3.3 V	-12 V	+5 VSB
Full (A)	14.6	9.1	11.5	0.3	1.7
Typical (A)	7.3	4.5	5.7	0.1	0.9
Light (A)	2.9	1.8	2.3	0.1	0.3

NOTES:

1. Loading calculated by method available at <http://www.efficientpowersupplies.org>.



15.2 Physical Dimensions - REQUIRED

Figure 57. Mechanical Outline

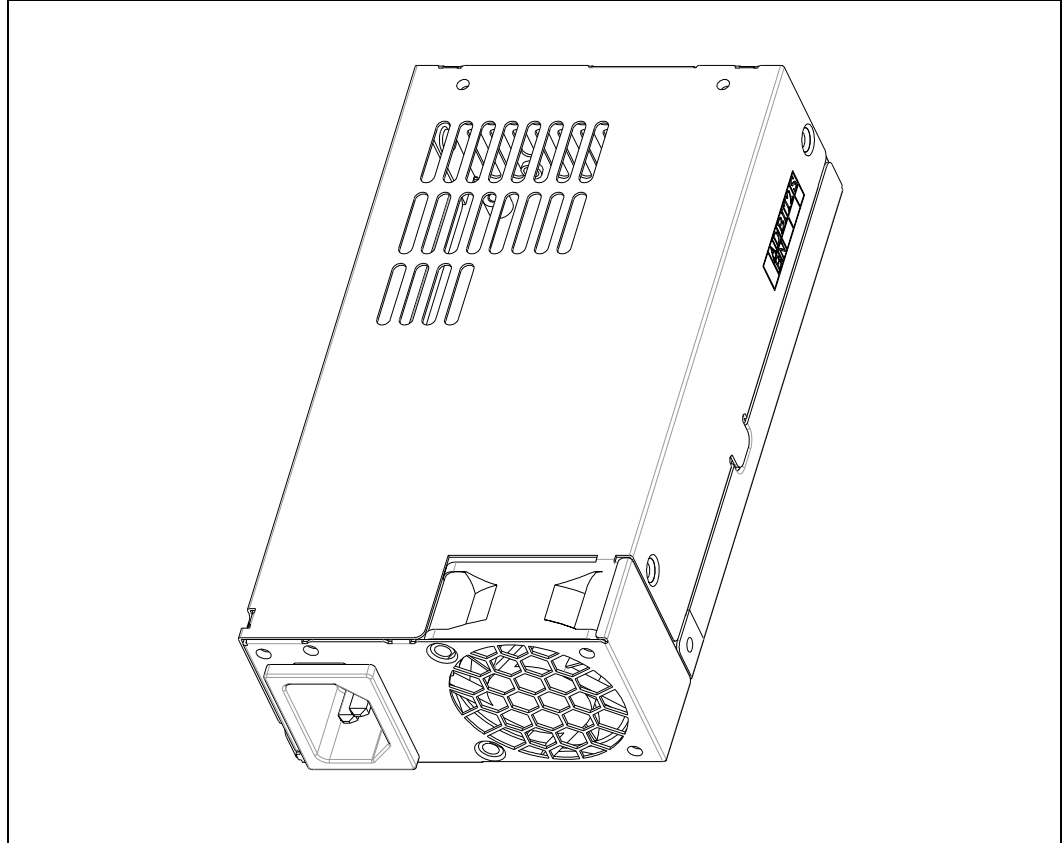

Figure 58. Dimensions & Recommended Feature Placements (not to scale)

