

OVER
35
YEARS

LIFTBOAT EXPERIENCE IN THE GULF OF MEXICO



MONTCO

Established 1948



L/B PAUL CLASS 235'

SELF-ELEVATING VESSEL -- YEAR BUILT - 2009
OFFICIAL NUMBER-1220726 CALL SIGN-WDE6198

DIMENSIONS:

Length (Overall)	137' (42.15 m)
Beam (Overall)	85'-10" (26.18 m)
Beam (Barge Only)	77' (23.69 m)
Depth (Barge Only)	11' 6" (3.57 m)
Design Draft	7' 6" (2.34 m)

HULL CHARACTERISTICS:

Gross Tonnage	155 Tons (1201 ITC)
Open Deck Area	6200 ft. ² (576 m ²)
Total Usable Space	7600 ft. ² (706 m ²)
Max. Deck Load	850,000 lbs. (386,363 kg)

LEGS:

Number	3
Length	235' (72.31 m)
Size	66" diameter x 1.5" wall thickness (106 cm diameter)
Material	API 5LX-70 KSI Steel 1-1/2" Wall

PADS:

Length	34' (10.46 m)
Width	18' (5.54 m)
Depth	5' 6" (1.72 m)
Configuration	Raked on both ends

CRANE CAPACITY:

Number	2 (API-2C Certified)
Crane 1	150 Tons @ 30' Radius (150 Tons @ 9.23m)
Boom Length	100' Lattice Type (30.77 m)
Heel Pin	12' (3.69 m) Above Deck
Crane 2	40 Tons @ 20' Radius (40 Tons @ 6.15m)
Boom Length	(Telescoping) 60'-90' (18.4m - 27.7m)

PROPULSION:

Main Engines	(2) Caterpillar C32
Horsepower/engine	1000 @ 1800 rpm
Reduction Gear	(2) TwinDisc MGX-5321
Propellers	(2) Workboat
Bow Thruster	300 hp Jastrum

CAPACITIES:

Fuel	24,000 gal (90,849 L)
Potable Water	23,400 gal (88,578 L)
Lube Oil	650 gal (2,460 L)
Hydraulic Oil	3,300 gal (12,491 L)
Submersible Pumps	2 @ 150 GPM each (2 @ 567.75 L/min)

GENERATORS:

Engines	(2) Caterpillar C9
Generators	(2) 215 KW

LIVING QUARTERS:

Berths	Total 42 (10 Crew / 32 PACs)
Galley	Ref., Fr., Ice Maker, Range
Sanitary Facilities	(16) Heads
Laundry	(3) Washers and (3) Dryers

NAVIGATION EQUIPMENT:

Radar, VHF's, Fathometer, Compass, Single Sideband, AIS, Auto Pilot, GPS, Anemometer, Electronic Charting, GMDSS Station, SSAS, SpeedDoppler

JACKING:

Max. Working Water Depth	180' (55.83 m)
Max. Height of Deck above mud line (Subtract Penetration)	222' (68.31 m)

SPECIAL FEATURES

Separate VIP Room Facilities, Zero Discharge Capability, Marine Sewage Treatment System, Walk-in Cooler & Freezer

ESTIMATED SPEED:

6 Knots

FUEL CONSUMPTION:

Main Engines	48 gal/hr = 1152 gal/day (182 L/hr = 4542 L/day)
Generators	17 gal/hr = 408 gal/day (64 L/hr = 1544 L/day)
Primary Crane Engine	24 gal/hr (91 L/hr.)

REGULATORY CLASSIFICATION:

USCG - O.S.V., SOLAS/MARPOL, ABS - Maltese Cross

235' Class L/B Working Water Depths

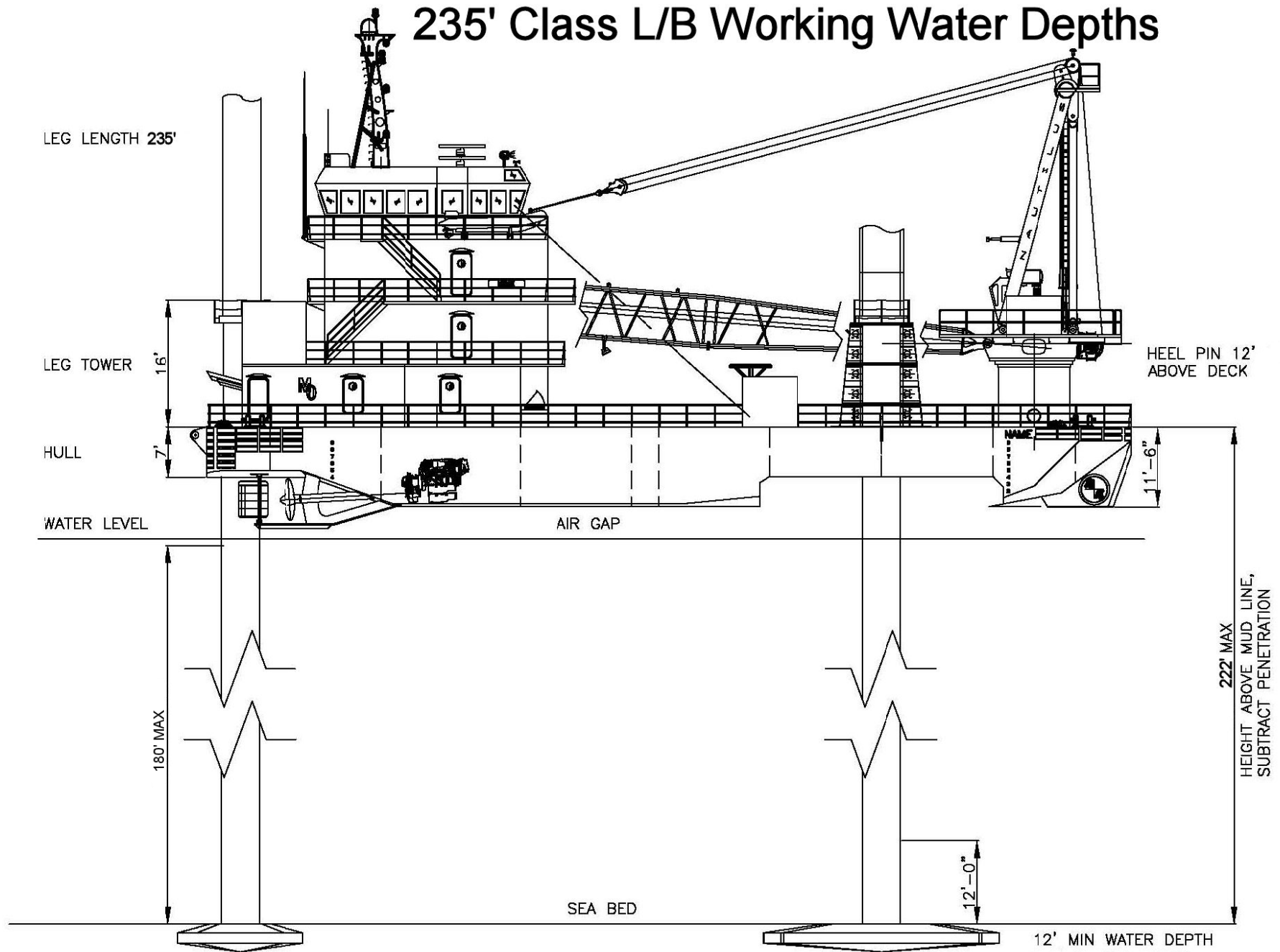

133'-0"

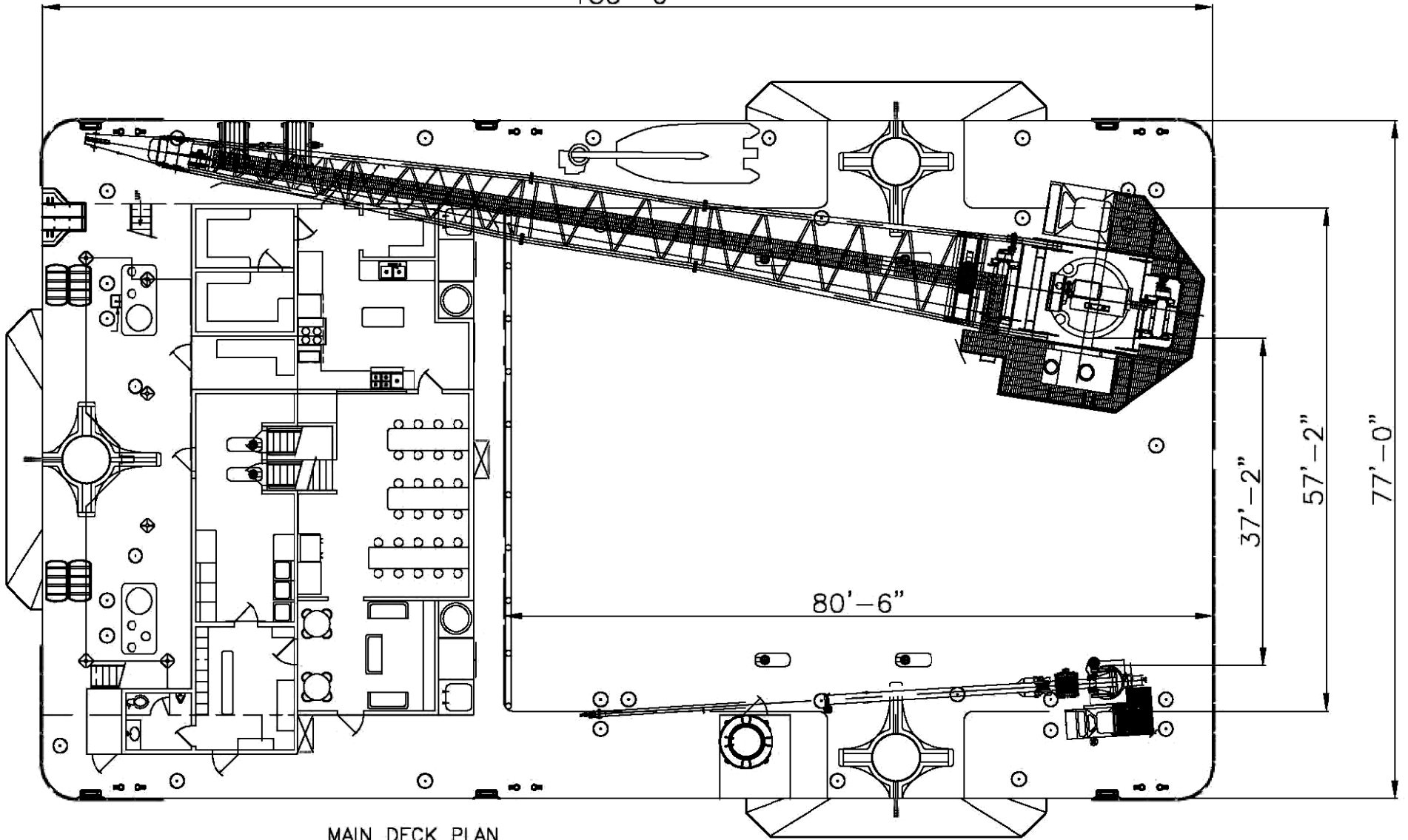

MAIN DECK PLAN

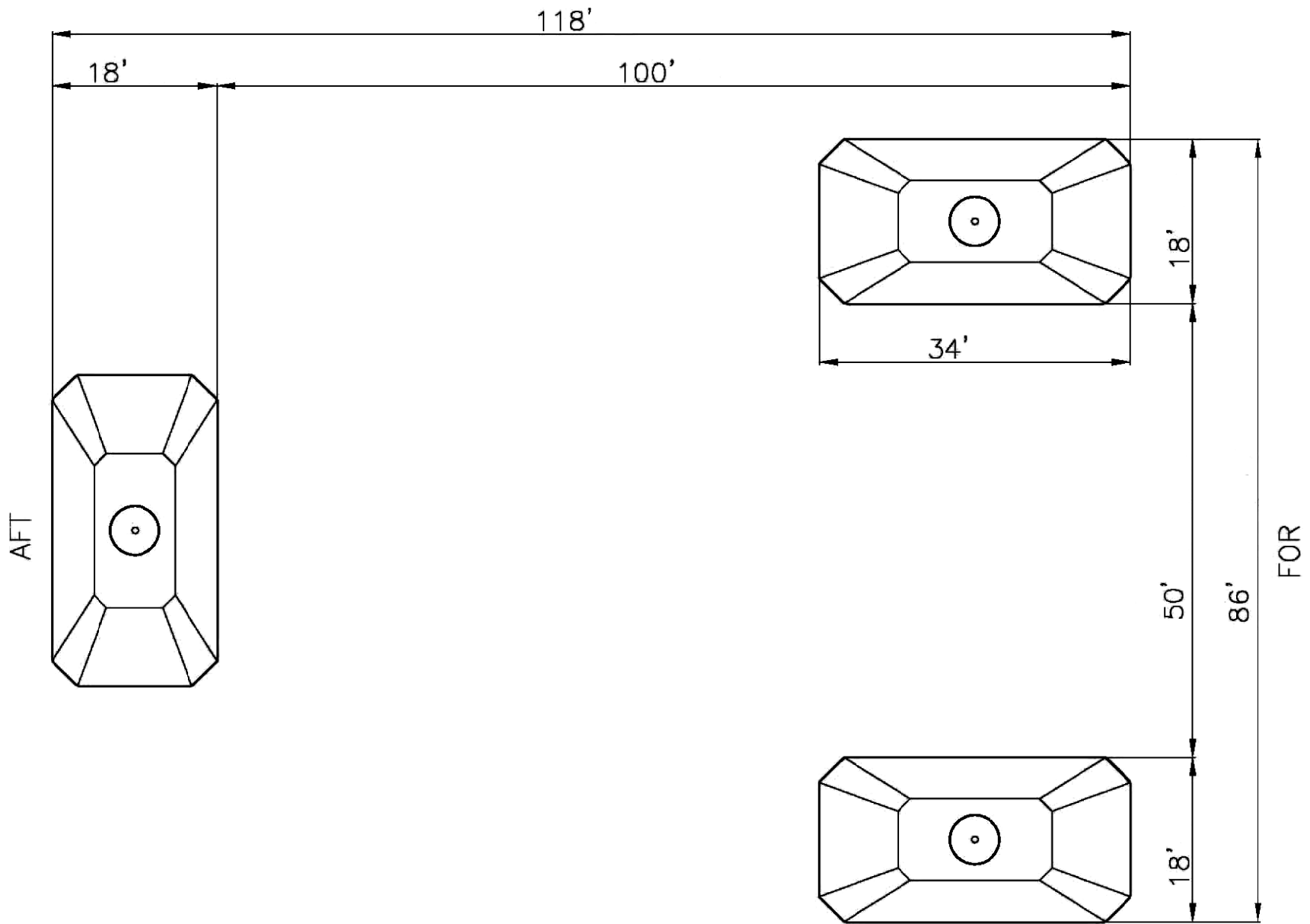

PAD ARRANGEMENT

		60 FOOT BOOM – RETRACTED						
RADIUS (FT)	BOOM ANGLE (DEG)	MAIN HOIST LOW SPEED		MAIN HOIST HIGH SPEED		AUXILIARY HOIST		
		SIX PART REEVING		SIX PART REEVING		SINGLE PART REEVING		
		ONBOARD (lbs)	OFFBOARD (lbs)	ONBOARD (lbs)	OFFBOARD (lbs)	ONBOARD (lbs)	OFFBOARD (lbs)	PERSONNEL (lbs)
8.1	83	80,000	53,333	50,880	50,880	7,669	7,669	2,154
10	81	80,000	53,333	50,880	50,880	7,669	7,669	2,154
15	76	70,454	46,569	50,880	46,569	7,669	7,669	2,154
20	71	55,543	36,629	50,880	36,629	7,669	7,669	2,154
25	66	46,179	30,398	46,197	30,398	7,669	7,669	2,154
30	61	38,707	25,405	38,707	25,405	7,669	7,669	2,154
35	55	32,522	21,281	32,522	21,281	7,669	7,669	2,154
40	49	27,792	18,128	27,792	18,128	7,669	7,669	2,154
45	42	24,078	15,652	24,078	15,652	7,669	7,669	2,154
50	34	21,078	13,652	21,078	13,652	7,669	7,669	2,154
55	24	18,605	12,003	18,605	12,003	7,669	7,669	2,154
60	0	16,450	10,567	16,450	10,567	7,669	7,669	2,154

DESIGN CONDITIONS	
METHOD USED	DEFAULT DYNAMIC
HOOK DROP	205 FT
MIN HOOK SPEED (MAIN LOW SPEED)	18 FPM
MIN HOOK SPEED (MAIN HIGH SPEED)	39 FPM
MIN HOOK SPEED (AUX.)	281 FPM

		90 FOOT BOOM – EXTENDED						
RADIUS (FT)	BOOM ANGLE (DEG)	MAIN HOIST LOW SPEED		MAIN HOIST HIGH SPEED		AUXILIARY HOIST		
		SIX PART REEVING		SIX PART REEVING		SINGLE PART REEVING		
		ONBOARD (lbs)	OFFBOARD (lbs)	ONBOARD (lbs)	OFFBOARD (lbs)	ONBOARD (lbs)	OFFBOARD (lbs)	PERSONNEL (lbs)
12	83	49,064	32,309	49,064	32,309	7,669	7,669	2,154
15	81	47,600	31,333	49,306	32,471	7,669	7,669	2,154
20	77	45,160	29,707	49,825	32,817	7,669	7,669	2,154
25	74	42,717	28,078	42,717	28,078	7,669	7,669	2,154
30	71	35,474	23,249	35,474	23,249	7,669	7,669	2,154
35	67	30,021	19,614	30,021	19,614	7,669	7,669	2,154
40	64	25,832	16,821	25,832	16,821	7,669	7,669	2,154
45	60	22,513	14,609	22,513	14,609	7,669	7,669	2,154
50	57	19,808	12,805	19,808	12,805	7,669	7,669	2,154
55	53	17,577	11,318	17,577	11,318	7,669	7,669	2,154
60	49	15,700	10,067	15,700	10,067	7,669	7,669	2,154
65	44	14,098	8,999	14,098	8,999	7,669	7,669	2,154
70	39	12,707	8,071	12,707	8,071	7,669	7,669	2,154
75	34	11,501	7,267	11,501	7,267	7,669	7,669	2,154
80	28	10,441	6,561	10,441	6,561	7,669	7,551	2,154
85	20	9,495	5,930	9,495	5,930	7,669	6,920	2,154
90	0	8,664	5,376	8,664	5,376	7,669	6,366	1,982

NOTE:

- 1) OFFBOARD LIFTS BASED ON SWL*Cv
- 2) Cv IS THE VERTICAL DYNAMIC COEFFICIENT DETERMINED BY THREE METHODS
 - * VESSEL SPECIFIC METHOD – USED FOR DETERMINING RATINGS FOR FLOATING PLATFORM / VESSEL
 - * GENERAL METHOD – USED FOR DETERMINING RATINGS FOR FLOATING PLATFORM / VESSEL OR FIXED PLATFORM
 - * DEFAULT DYNAMIC METHOD – OFFBOARD LIFTS FROM FIXED PLATFORM (Cv=2.0)
- 3) SHEAVE EFFICIENCY CONSIDERED.
- 4) THE ABOVE RATINGS ARE NET RATINGS AS THE MAIN LOAD BLOCK WEIGHT OF 1200 LBS. AND THE AUXILIARY OVERHAUL BALL WEIGHT OF 210 LBS. HAVE ALREADY BEEN SUBTRACTED TO DETERMINE "NET" CAPACITY.
- 5) REFERENCE MANUAL FOR REEVING DIAGRAMS.
- 6) REFERENCE INFORMATION CHART FOR REEVING DETAILS.
- 7) ALL RATINGS IN ACCORDANCE WITH API SPECIFICATION 2C (SPEC 2C), SIXTH EDITION, SEPTEMBER 2004.



MARINE CRANES
HOUMA, LOUISIANA 70363
(985) 868-0630

LIFTING LOAD CAPACITY CHART
NAUTILUS MODEL 1100L-100 MARINE CRANE



RADIUS (FT)	BOOM ANGLE (DEG)	MAIN HOIST		AUXILIARY HOIST		
		12 PART REEVING		2 PART REEVING		PERSONNEL (lbs)
		ONBOARD (lbs)	OFFBOARD (lbs)	ONBOARD (lbs)	OFFBOARD (lbs)	
24	81	330,000	220,000	22,211	20,000	8,654
25	80	330,000	220,000	22,211	20,000	8,654
30	77	300,280	198,196	22,211	20,000	8,654
35	74	256,816	169,210	22,211	20,000	8,654
40	71	223,532	147,021	22,211	20,000	8,654
45	68	197,232	129,488	22,211	20,000	8,654
50	65	175,930	115,286	22,211	20,000	8,654
55	62	158,326	103,550	22,211	20,000	8,654
60	59	143,686	93,790	22,211	20,000	8,654
65	55	131,071	85,380	22,211	20,000	8,654
70	52	120,193	78,128	22,211	20,000	8,654
75	48	110,714	71,809	22,211	20,000	8,654
80	44	102,380	66,253	22,211	20,000	8,654
85	39	94,995	61,330	22,211	20,000	8,654
90	35	88,309	56,872	22,211	20,000	8,654
95	29	82,398	52,932	22,211	20,000	8,654
100	22	77,055	49,370	22,211	20,000	8,654
105	12	72,191	46,127	22,211	20,000	8,654
106	0	70,297	44,864	22,211	20,000	8,654

NOTE:

- 1) OFFBOARD LIFTS BASED ON SWL*Cv
- 2) Cv IS THE VERTICAL DYNAMIC COEFFICIENT DETERMINED BY THREE METHODS
 - * VESSEL SPECIFIC METHOD - USED FOR DETERMINING RATINGS FOR FLOATING PLATFORM / VESSEL
 - * GENERAL METHOD - USED FOR DETERMINING RATINGS FOR FLOATING PLATFORM / VESSEL OR FIXED PLATFORM
 - * DEFAULT DYNAMIC METHOD - OFFBOARD LIFTS FROM FIXED PLATFORM (Cv=2.0)
- 3) SHEAVE EFFICIENCY CONSIDERED.
- 4) THE ABOVE RATINGS ARE NET RATINGS AS THE MAIN LOAD BLOCK WEIGHT OF 6000 LBS. AND THE AUXILIARY LOAD BLOCK WEIGHT OF 390 LBS. HAVE ALREADY BEEN SUBTRACTED TO DETERMINE "NET" CAPACITY.
- 5) REFERENCE MANUAL FOR REEVING DIAGRAMS.
- 6) REFERENCE INFORMATION CHART FOR REEVING DETAILS.
- 7) ALL RATINGS IN ACCORDANCE WITH API SPECIFICATION 2C (SPEC 2C), SIXTH EDITION, SEPTEMBER 2004.

CRANE S/N: 21607C

LOCATION: LIFTBOAT MOTOR VESSEL

REV: B
P/N: N2007SK3-062

