

# 16 S 1630 TD ZF-Ecosplit (Truck)

Synchromesh transmission for heavy trucks

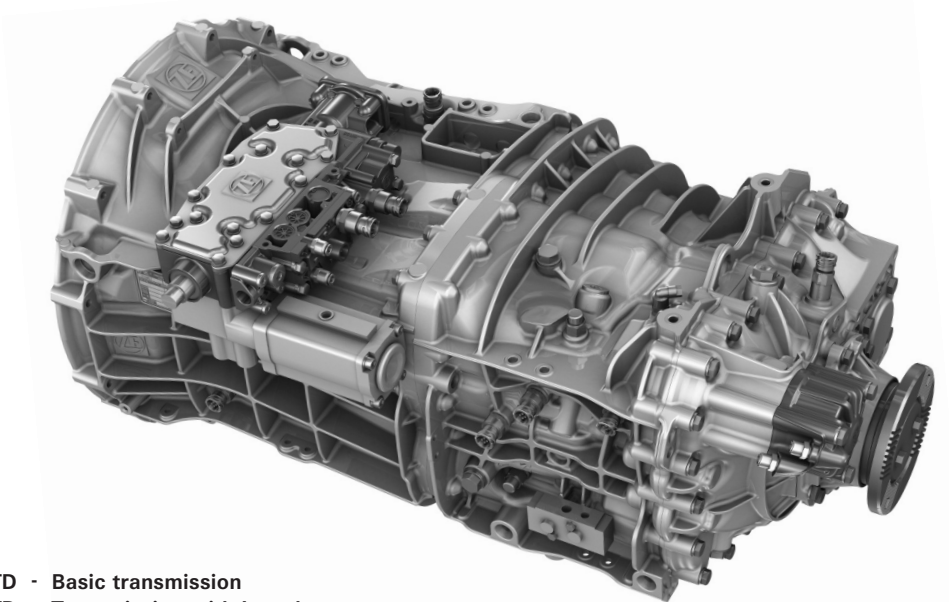

- 16 S 1630 TD - Basic transmission
- 16 S 1631 TD - Transmission with Intarder
- 16 S 1633 TD - Transmission designed for 100% coasting torque
- 16 S 1635 TD - Transmission with clutch-dependent PTO

SERVOSHIFT is the standard shift system in all transmission versions.

<b>Transmission type</b>	<b>16 S 1630 TD</b>
<b>Input torque</b>	max. 1600 Nm
<b>Weight</b> without auxiliaries	≈ 284 kg
<b>Additional weight</b> for ZF-Intarder	≈ 70 kg
<b>Oil capacity</b> for standard installation	≈ 13.4 dm <sup>3</sup>
<b>Oil capacity</b> for transmission with ZF-Intarder	≈ 23.5 dm <sup>3</sup>
<b>Oil grade</b>	as specified in ZF List of Lubricants TE-ML 01 or TE-ML 02
<b>Installation</b>	horizontal left, with integrated clutch bell

**Standard ratios in gears** (L = splitter low; H = splitter high)

1		2		3		4		5		6		7		8		R	
L	H	L	H	L	H	L	H	L	H	L	H	L	H	L	H	L	H
16.41	13.80	11.28	9.49	7.76	6.53	5.43	4.57	3.59	3.02	2.47	2.08	1.70	1.43	1.19	1.00	15.36	12.92

→ see also Data Sheet for Intarder: IT\_Ecosplit\_EN

# 16 S 1630 TD

## Installation dimensions

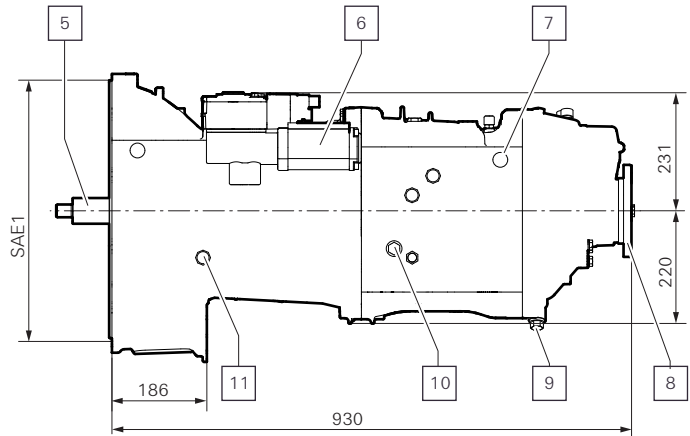
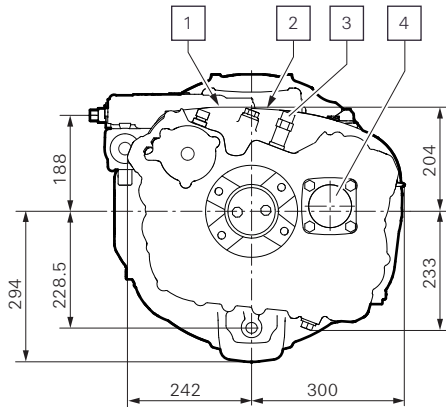

- |   |                                     |
|---|-------------------------------------|
| 1 "Neutral" signal transmitter                  | 6 Servoshift                        |
| 2 "Reverse gear" signal transmitter             | 7 "Range change" signal transmitter |
| 3 Speedometer connection, electronic (optional) | 8 Output                            |
| 4 Connection point for clutch-dependent ZF-PTOs | 9 Oil drain                         |
| 5 Input   | 10 Oil fill and oil overflow check  |
|   | 11 "Splitter" signal transmitter    |

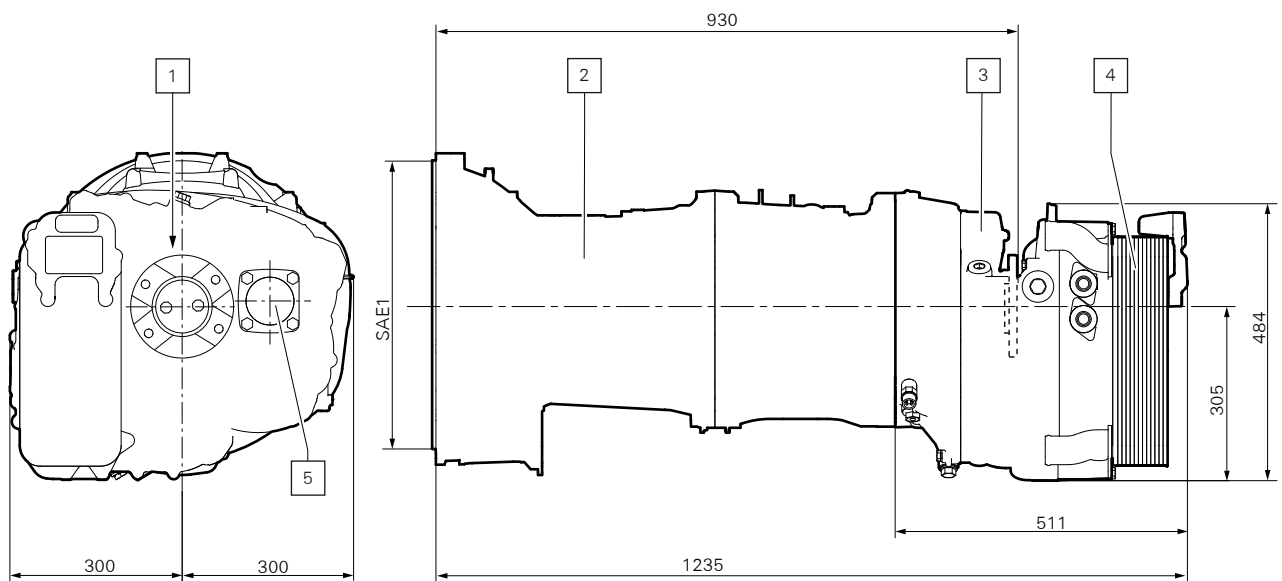

- |                                     |                            |
|-------------------------------------|----------------------------|
| 1 Option to fit steering pump drive | 4 Oil/water heat exchanger |
| 2 ZF-Ecosplit transmission          | 5 Connection for PTO       |
| 3 ZF-Intarder unit                  |                            |