

12 S 2833 TD Project information ZF-Ecosplit (Truck)

Synchromesh transmission for heavy trucks



- 12 S 2833 TD** - Basic transmission, designed for 100% coasting torque
- 12 S 2831 TD** - Transmission with Intarder
- 12 S 2835 TD** - Transmission with clutch-dependent PTO

SERVOSHIFT is the standard shift system in all transmission versions.

Transmission type	12 S 2833 TD
Input torque	max. 2800 Nm
Weight without auxiliaries	≈ 310 kg
Additional weight for ZF-Intarder	≈ 70 kg
Oil capacity for standard installation	≈ 13.0 dm ³
Oil capacity for transmission with ZF-Intarder	≈ 23.0 dm ³
Oil grade	as specified in ZF List of Lubricants TE-ML 01 or TE-ML 02
Installation	horizontal left, with integrated clutch bell

Standard ratios in gears (L = splitter low; H = splitter high)

1		2		3		4		5		6		R	
L	H	L	H	L	H	L	H	L	H	L	H	L	H
15.57	12.21	9.47	7.43	5.82	4.56	3.41	2.68	2.07	1.63	1.27	1.00	14.57	11.44

➔ see also Data Sheet for Intarder: [IT_Ecosplit_EN](#)

12 S 2833 TD

Installation dimensions

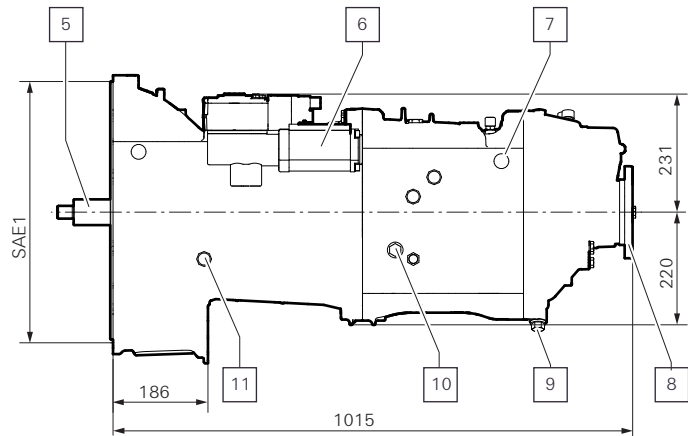
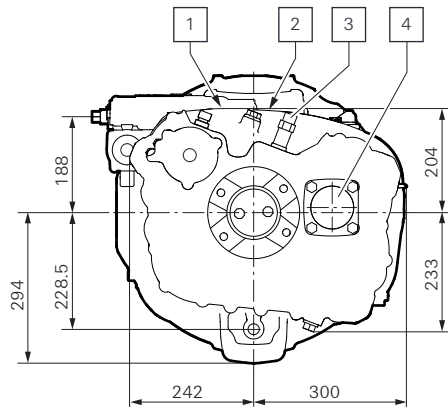

- 1 "Neutral" signal transmitter
- 2 "Reverse gear" signal transmitter
- 3 Speedometer connection, electronic (optional)
- 4 Connection point for clutch-dependent ZF-PTOs
- 5 Input

- 6 Servoshift
- 7 "Range change" signal transmitter
- 8 Output
- 9 Oil drain
- 10 Oil fill and oil overflow check
- 11 "Splitter" signal transmitter

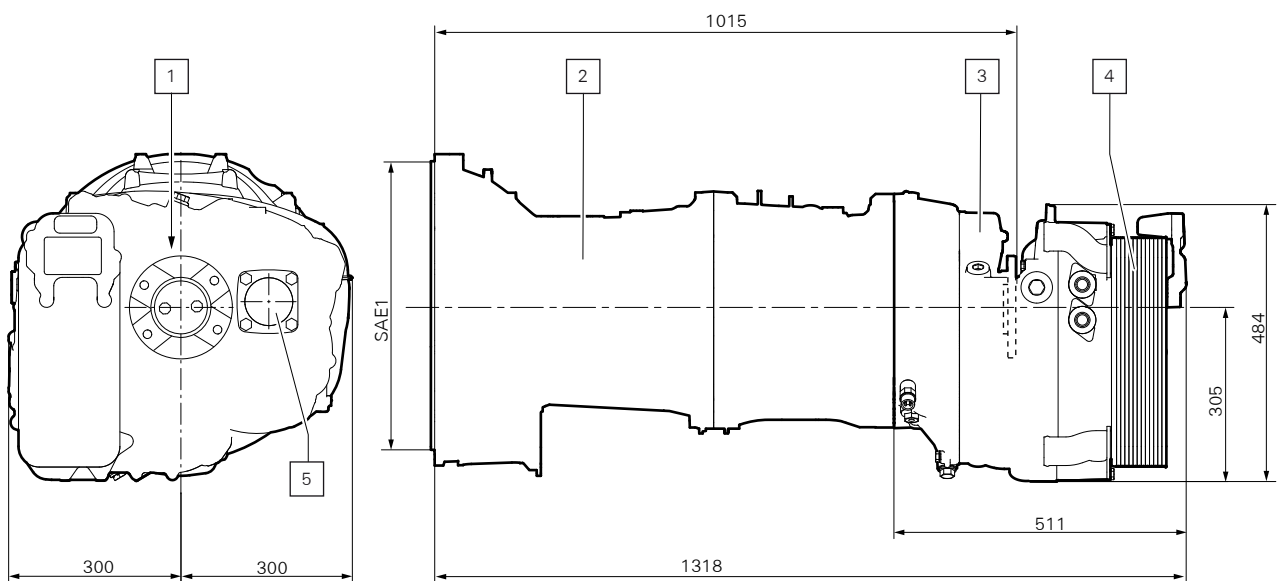

- 1 Option to fit steering pump drive
- 2 ZF-Ecosplit transmission
- 3 ZF-Intarder unit

- 4 Oil/water heat exchanger
- 5 Connection for PTO