

16 S 1620 TD ZF-Ecosplit (Truck)

Synchromesh transmission for heavy trucks

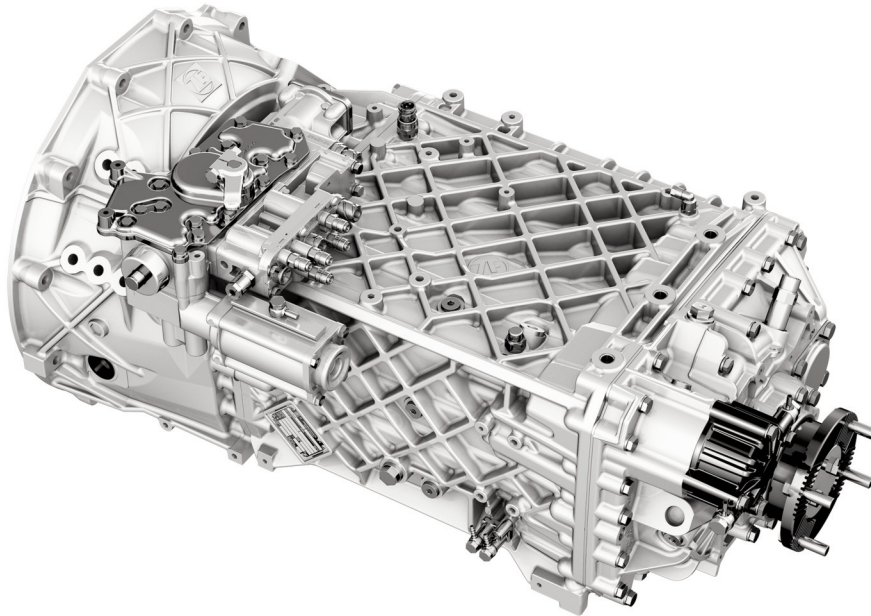

- 16 S 1620 TD - Basic transmission
- 16 S 1621 TD - Transmission with Intarder
- 16 S 1623 TD - Transmission designed for 100% coasting torque
- 16 S 1625 TD - Transmission with clutch-dependent PTO

SERVOSHIFT is the standard shift system in all transmission versions.

Transmission type	16 S 1620 TD
Input torque	max. 1600 Nm
Weight without auxiliaries	≈ 289 kg
Oil capacity for standard installation	≈ 11 dm ³
Oil grade	as specified in ZF List of Lubricants TE-ML 01 and/or TE-ML 02
Installation	horizontal left, with integrated clutch bell
Additional weight for ZF-Intarder	≈ 69 kg
Additional oil quantity for ZF-Intarder	≈ 8 dm ³

Standard ratios in gears (L = splitter low; H = splitter high)

1		2		3		4		5		6		7		8		R	
L	H	L	H	L	H	L	H	L	H	L	H	L	H	L	H	L	H
16.41	13.80	11.28	9.49	7.76	6.53	5.43	4.57	3.59	3.02	2.47	2.08	1.70	1.43	1.19	1.00	15.36	12.92

→ see also Data Sheet for Intarder: IT_NewEcosplit_EN

16 S 1620 TD

Installation dimensions

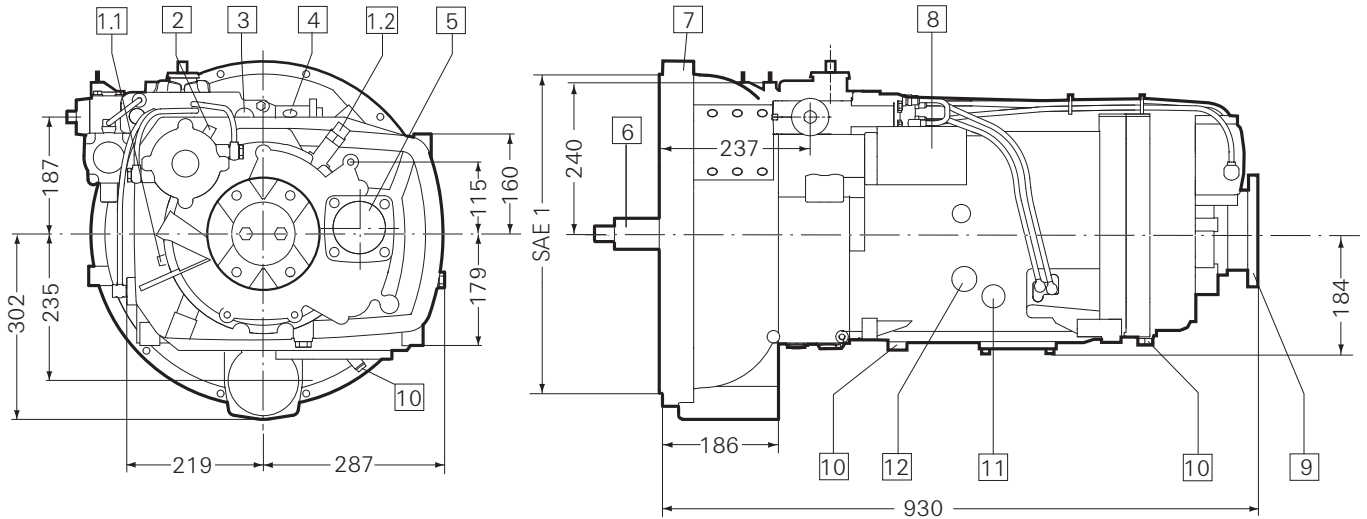

- | | |
|---|------------------------------------|
| 1 Speedometer connection, electronic (optional) | 7 Integrated clutch bell |
| 2 "Range change" signal transmitter | 8 Servoshift |
| 3 "Neutral" signal transmitter | 9 Output |
| 4 "Reverse gear" signal transmitter | 10 Oil drain |
| 5 Connection point for clutch-dependent ZF-PTOs | 11 "Splitter" signal transmitter |
| 6 Input | 12 Oil fill and oil overflow check |

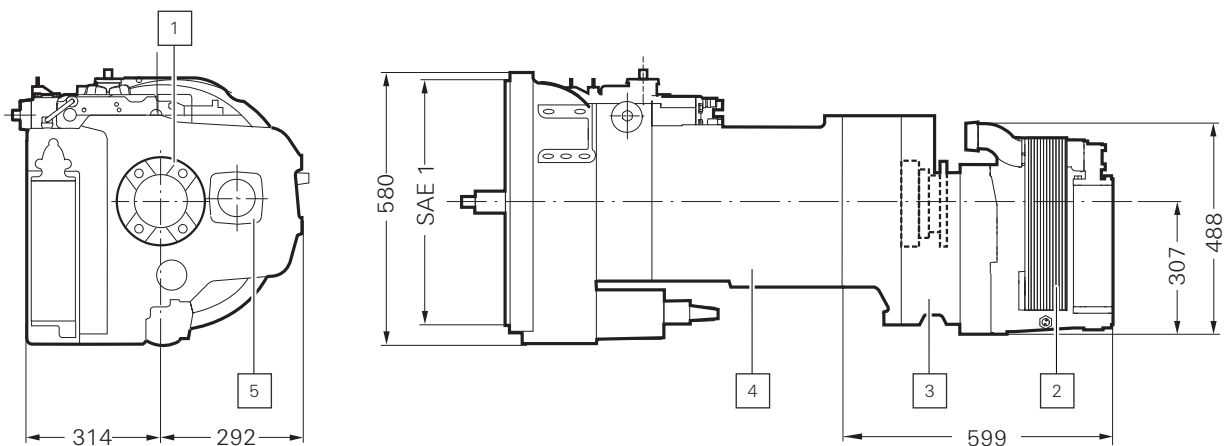

- | | |
|-------------------------------------|----------------------------|
| 1 Option to fit steering pump drive | 4 Oil/water heat exchanger |
| 2 ZF-Ecosplit transmission | 5 Connection for PTO |
| 3 ZF-Intarder unit | |