

Boral **Roofing**
Build something great™



Lightweight Roof Tiles

REROOF CONCRETE TILE COLLECTION



Concrete Roof Tiles

Few roof products are as beautiful or enduring as Boral concrete roof tiles. With so many styles and colors to choose from, you'll find that adding a tile roof to your home is one of the easiest and most effective ways to complement its look and increase its value.



Natural
& Extensive
Color Offering



BORAL'S INNOVATIVE PRODUCTS ARE SUSTAINABLE, DURABLE AND BEAUTIFUL



Boral Products are featured in the VISION House® in INNOVENTIONS presented by Green Builder® Media. This green home exhibit is located in INNOVENTIONS at Epcot® at the Walt Disney World® Resort.



Popular Mechanics' Winner 2011 Breakthrough Award
The year's 10 Most Transformative Products

HOME AND HARDWARE
BoralPure® Technology
Smog Eating Concrete Tile

2012 Best New Product Edison Gold Award Winner

MATERIAL SCIENCE
Safety & Sustainability
BoralPure® Technology
Smog Eating Concrete Tile





Tile is timeless

Only tile enables you to achieve authentic, old-world aesthetics with the benefits of durable, modern materials. Boral Roofing has captured all the characteristics of natural slate, clay and wood – which are historically the world’s most widespread roofing materials – in a concrete tile. The result is a tile roof of unmatched beauty and a home with incredible curb appeal.

Boral Roofing is continually acknowledged by the industry for our product innovations. And three of our most popular products - Cedarlite®, Duralite® Saxony® Slate and Duralite® España - replicate authentic materials, while reducing installation costs and increasing longevity and energy efficiency.



In Stock

Lightweight products are kept in stock at the plant and are available for immediate pick up. Please call customer service at 1.800.669.8453 to confirm product quantities before arriving.

Code Approval: Complies with all building codes including but not limited to ICC ESR-1647. Some approvals are regional and only apply to locally produced products; please contact Boral Roofing before transporting product across state lines. Specifically, products used in the Miami Dade County region of Florida require special testing and recognition. All concrete tiles are Class A fire rated.

Disclaimer: The printed colors shown in this brochure may vary from actual available tile colors. Before making a final selection, be sure to review actual tile samples and roof installations. Please contact your local sales office for further assistance. Inadvertent errors in this publication are subject to change without notice. No performance guarantee is offered or implied beyond that expressly indicated.

Efflorescence is a temporary surface condition which is common to all concrete products. The process is caused by the chemical nature of cement. This reaction can appear as an overall chalky white bloom (a softening of color) or in more concentrated patches. It is difficult to predict how long the effects of efflorescence will last. It depends on the type and amount of deposit as well as local weather conditions. The action of carbon dioxide and rainwater will gradually remove the deposit, in most cases, leaving the original color of the roof intact without further efflorescence occurring. It is superficial and in no way affects the quality or functional properties of the tile.

Installation: Please consult the Tile Roofing Institute (TRI) Installation guides for application recommendations.



Choose from one of our many cool roof rated tiles that will improve the energy efficiency by reflecting sunlight and heat away from your roof. When these are combined with our Elevated Batten System, they will provide reduced cooling costs and they may even qualify for local rebates. The Cool Roof Rating Council (CRRC) measures the “coolness” of a roof by determining a roof’s solar reflectance (SR) and thermal emittance (TE). Both properties are rated on a scale from 0 to 1, where 1 is the most reflective or emissive. The CRRC measures these two properties for roofing products, both for the product’s initial values and after three years of weather exposure. Boral Roofing manufactures some products that meet CRRC guidelines, allowing homeowners in some regions to receive utility rebates. Boral Roofing’s CRRC rated products help reduce the heat island effect found in urban areas and in general, increases the overall energy efficiency of the building. For current product ratings please visit our website at www.boralroof.com and click on CRRC logo on the home page.

Cedarlite® 600 & Madera 700



“The Ultimate Shake Replacement”, CedarLite® 600 and Madera 700 represent a quantum leap in concrete roof tile aesthetics. Modeled after traditional heavy hand-split cedar shakes, these products were developed to deliver a true rustic, realistic wood appearance, while adding the superior features and benefits inherent in concrete tile.

Coverage	Approx. Installed Weight / Square	Pieces Per Pallet	Squares Per Pallet	Approx. Weight Per Pallet
At 3-1/2" minimum headlap, 120 field tiles will cover approx. 100 square feet of roof area.	Cedarlite 600: 590 lbs.	412	3.43	2,480 lbs.
	Madera 700: 720 lbs.	412	3.43	2,895 lbs.



Cedarlite® 600

Heartwood

2CLCL3783



CRRC Rated Product - 0942-0060
Ref: .12 / Emit: .91 / SRI: 9 / Aged SRI: 12

Ironwood

2CLCL5773



CRRC Rated Product - 0942-0080
Ref: .11 / Emit: .93 / SRI: 9 / Aged SRI: 13

Silverwood

2CLCL5780



CRRC Rated Product - 0942-0059
Ref: .12 / Emit: .95 / SRI: 11 / Aged SRI: 14

Autumnwood

2CLCL3002



CRRC Rated Product - 0942-0070
Ref: .13 / Emit: .87 / SRI: 8 / Aged SRI: 11

Tahoe Blend

2CLCL3230



CRRC Rated Product - 0942-0169
Ref: .17 / Emit: .91 / SRI: 16 / Aged SRI: 17

Winterwood Blend

2CLCL5120



CRRC Rated Product - 0942-0183
Ref: .21 / Emit: .91 / SRI: 21 / Aged SRI: 20

Elkwood

2CLCL0072



CRRC Rated Product - 0942-0081
Ref: .16 / Emit: .94 / SRI: 16 / Aged SRI: 17



Madera 700

Autumnwood

3MDCL3002



CRRC Rated Product - 0942-0070
Ref: .13 / Emit: .87 / SRI: 8 / Aged SRI: 11

Vintagewood

3MDCL5011



CRRC Rated Product - 0942-0089
Ref: .12 / Emit: .94 / SRI: 11 / Aged SRI: 13

Heartwood

3MDCL3783



CRRC Rated Product - 0942-0060
Ref: .12 / Emit: .91 / SRI: 9 / Aged SRI: 12

Mountainwood

3MDCL5001



CRRC Rated Product - 0942-0110
Ref: .08 / Emit: .93 / SRI: 5 / Aged SRI: 10

Tahoe Blend

3MDCL3230



CRRC Rated Product - 0942-0169
Ref: .17 / Emit: .91 / SRI: 16 / Aged SRI: 17

Winterwood Blend

3MDCL5120



CRRC Rated Product - 0942-0183
Ref: .21 / Emit: .91 / SRI: 21 / Aged SRI: 20

Elkwood

3MDCL0072



CRRC Rated Product - 0942-0081
Ref: .16 / Emit: .94 / SRI: 16 / Aged SRI: 17



Madera Autumnwood



Duralite® Saxony® Split Shake 600/700

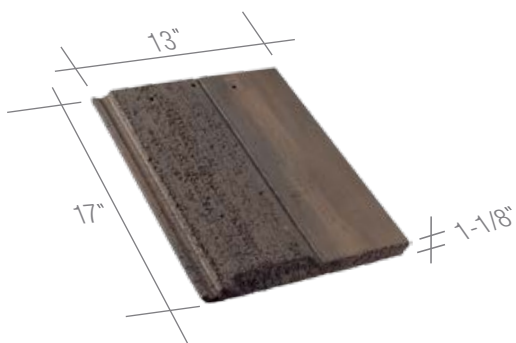

This classic variation of both shake and slate tile adds a distinctive architectural style. Split Shake tiles are best suited for Cottage, French Country and Traditional American Homes. They look best when installed with a random offset between courses.

Coverage	Approx. Installed Weight / Square	Pieces Per Pallet	Squares Per Pallet	Approx. Weight Per Pallet
At 3" minimum headlap, 85 field tiles will cover approx. 100 square feet of roof area.	Saxony 600: 570 lbs.	312	3.67	2,680 lbs.
	Saxony 700: 720 lbs.	288	3.39	2,800 lbs.

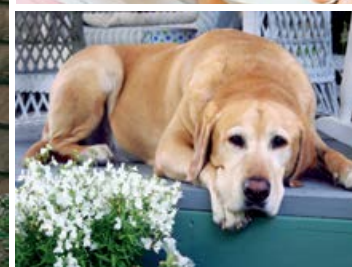

Compliant with
California Title 24, 2013
Aged SRI requirement.

Actual Aged SRI # / Calculated Aged SRI #

Camouflage

600: 2FDCV3963 / 700: 3FDCV3963



CRRC Rated Product - 0942-0085
Ref: .11 / Emit: .94 / SRI: 10 / Aged SRI: 13

Smokey

600: 2FDCV3958 / 700: 3FDCV3958



CRRC Rated Product - 0942-0063
Ref: .08 / Emit: .92 / SRI: 5 / Aged SRI: 10

Wolf Grey

600: 2FDCV5969 / 700: 3FDCV5969



CRRC Rated Product - 0942-0090
Ref: .11 / Emit: .91 / SRI: 8 / Aged SRI: 12

La Terra Blend

600: 2FDCV6031 / 700: 3FDCV6031



CRRC Rated Product - 0942-0075
Ref: .21 / Emit: .87 / SRI: 19 / Aged SRI: 19

Buckskin

600: 2FDCV0141 / 700: 3FDCV0141



CRRC Rated Product - 0942-0009
Ref: .22 / Emit: .90 / SRI: 22 / Aged SRI: 24

Stone Mountain Blend

600: 2FDCV5354 / 700: 3FDCV5354



CRRC Rated Product - 0942-0047
Ref: .17 / Emit: .90 / SRI: 15 / Aged SRI: 16

Tahoe Blend

600: 2FDCV3230 / 700: 3FDCV3230



CRRC Rated Product - 0942-0169
Ref: .17 / Emit: .91 / SRI: 16 / Aged SRI: 17

Duralite® Saxony® Slate 600/700

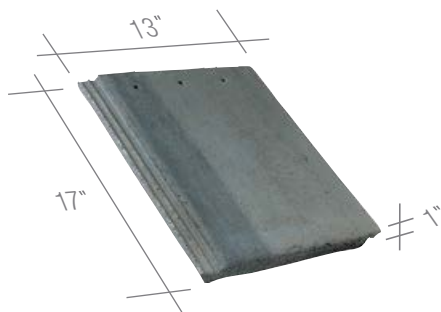

The beautiful design of Saxony® Slate delivers the aspirational aesthetics of traditional slate roofs found in Tudor and French Colonial architecture. Available in a broad range of colors, Saxony® Slate captures the appearance of natural slate, while delivering the inherent benefits of concrete tile.

Coverage	Approx. Installed Weight / Square	Pieces Per Pallet	Squares Per Pallet	Approx. Weight Per Pallet
At 3" minimum headlap, 85 field tiles will cover approx. 100 square feet of roof area.	Saxony 600: 570 lbs.	312	3.67	2,680 lbs.
	Saxony 700: 720 lbs.	288	3.39	2,800 lbs.



Tahoe Blend

600: 2FACS3230 / 700: 3FACS3230



CRRC Rated Product - 0942-0169
Ref: .17 / Emit: .91 / SRI: 16 / Aged SRI: 17

Hillside

600: 2FACS3935 / 700: 3FACS3935



CRRC Rated Product - 0942-0067
Ref: .13 / Emit: .93 / SRI: 12 / Aged SRI: 14

Cobblestone

600: 2FACS3957 / 700: 3FACS3957



CRRC Rated Product - 0942-0062
Ref: .11 / Emit: .90 / SRI: 8 / Aged SRI: 11

La Terra Blend

600: 2FACS6031 / 700: 3FACS6031



CRRC ID# - 0942-0075
Ref: .21 / Emit: .87 / SRI: 19 / Aged SRI: 19

California Mission Blend

600: 2FACS6464 / 700: 3FACS6464



CRRC Rated Product - 0942-0008
Ref: .19 / Emit: .91 / SRI: 18 / Aged SRI: 24

Charcoal Brown Blend

600: 2FACS1132 / 700: 3FACS1132



CRRC Rated Product - 0942-0005
Ref: .18 / Emit: .91 / SRI: 17 / Aged SRI: 19



Duralite® Saxony® Slate 600/700

Stone Mountain Blend

600: 2FACS5354 / 700: 3FACS5354



CRRC Rated Product - 0942-0047
Ref: .17 / Emit: .90 / SRI: 15 / Aged SRI: 16

Buckskin

600: 2FACS0141 / 700: 3FACS0141



CRRC Rated Product - 0942-0009
Ref: .22 / Emit: .90 / SRI: 22 / Aged SRI: 21

Lincoln Green

600: 2FACS4087 / 700: 3FACS4087



CRRC Rated Product - 0942-0087
Ref: .18 / Emit: .90 / SRI: 16 / Aged SRI: 18

Charcoal Blend

600: 2FACS1430 / 700: 3FACS1430



CRRC Rated Product - 0942-0072
Ref: .17 / Emit: .91 / SRI: 16 / Aged SRI: 17

Rustic Brown Blend

600: 2FACS3184 / 700: 3FACS3184



CRRC Rated Product Pending



Slate Buckskin



Compliant with
California Title 24, 2013
Aged SRI requirement.



Duralite® Saxony® Shake 600/700



Saxony® Shake roof tile perfectly captures the rustic warmth and beauty of country living by recreating the look of hand-hewn shakes. Ideal for French Country, Victorian Craftsman or Cottage architectural styling, these home designs can be enhanced with the diverse color spectrum of the Saxony® Shake Collection.

Coverage	Approx. Installed Weight / Square	Pieces Per Pallet	Squares Per Pallet	Approx. Weight Per Pallet
At 3" minimum headlap, 85 field tiles will cover approx. 100 square feet of roof area.	Saxony 600: 570 lbs.	312	3.67	2,680 lbs.
	Saxony 700: 720 lbs.	288	3.39	2,800 lbs.

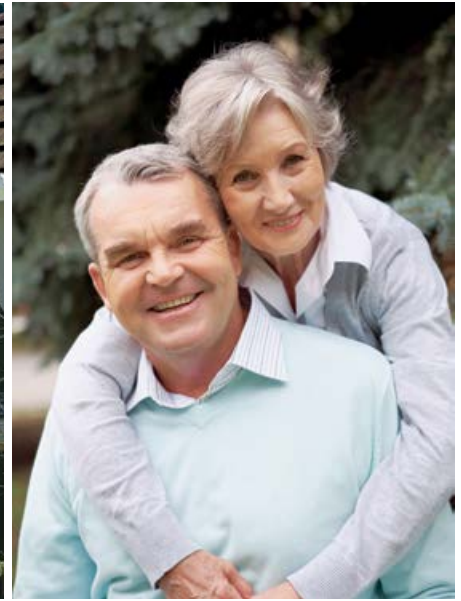

Buckskin

600: 2FBCF0141 / 700: 3FBCF0141

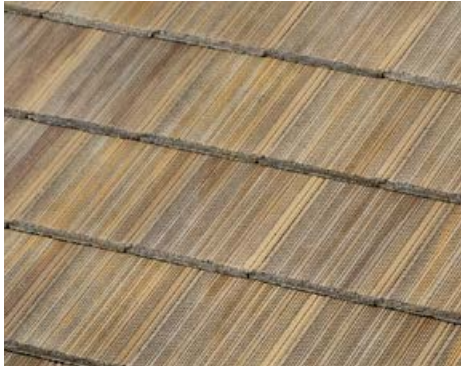

CRRC Rated Product - 0942-0009
Ref: .22 / Emit: .90 / SRI: 22 / Aged SRI: 21

Tahoe Blend

600: 2FBCJ3230 / 700: 3FBCJ3230



CRRC Rated Product - 0942-0169
Ref: .17 / Emit: .91 / SRI: 16 / Aged SRI: 17

Silver Smoke

600: 2FBCF5932 / 700: 3FBCF5932



CRRC Rated Product - 0942-0066
Ref: .12 / Emit: .92 / SRI: 10 / Aged SRI: 12

Saddle

600: 2FBCF3934 / 700: 3FBCF3934



CRRC Rated Product - 0942-0068
Ref: .15 / Emit: .90 / SRI: 13 / Aged SRI: 15

La Terra Blend

600: 2FBCJ6031 / 700: 3FBCJ6031



CRRC ID# - 0942-0075
Ref: .21 / Emit: .87 / SRI: 19 / Aged SRI: 19

Stone Mountain Blend

600: 2FBCF5354 / 700: 3FBCF5354



CRRC Rated Product - 0942-0047
Ref: .17 / Emit: .90 / SRI: 15 / Aged SRI: 16

Walnut

600: 2FBCF3453 / 700: 3FBCF3453



CRRC Rated Product - 0942-0061
Ref: .12 / Emit: .94 / SRI: 11 / Aged SRI: 13

Smokey

600: 2FBCF3958 / 700: 3FBCF3958



CRRC Rated Product - 0942-0063
Ref: .08 / Emit: .92 / SRI: 5 / Aged SRI: 10

Charcoal

600: 2FBCF1130 / 700: 3FBCF1130

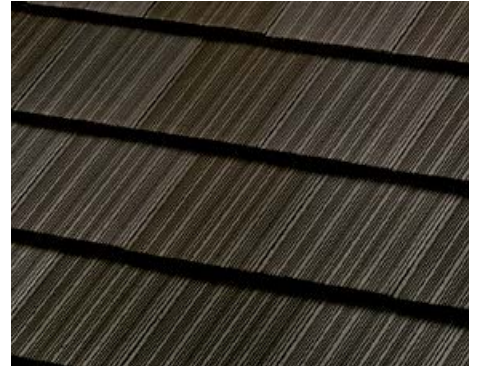

CRRC Rated Product - 0942-0064
Ref: .08 / Emit: .92 / SRI: 5 / Aged SRI: 10

Duralite® Saxony® Shake 600/700

Rustic Brown Blend

600: 2FBCJ3184 / 700: 3FBCJ3184



CRRC Rated Product Pending

California Mission Blend

600: 2FBCJ6464 / 700: 3FBCJ6464



CRRC Rated Product - 0942-0008
Ref: .19 / Emit: .91 / SRI: 18 / Aged SRI: 24

Charcoal Brown Blend

600: 2FBCJ1132 / 700: 3FBCJ1132



CRRC Rated Product - 0942-0005
Ref: .18 / Emit: .91 / SRI: 17 / Aged SRI: 19

Charcoal Blend

600: 2FBCJ1430 / 700: 3FBCJ1430



CRRC Rated Product - 0942-0072
Ref: .17 / Emit: .91 / SRI: 16 / Aged SRI: 17





Duralite® España® 600

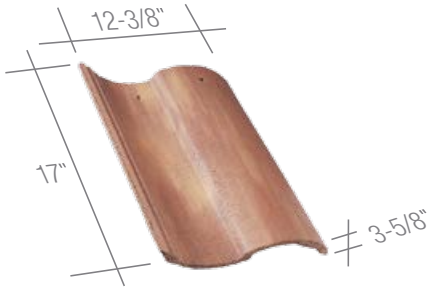

España® 600 reflects the classic style and distinctiveness of Spanish architecture, popular in the early California missions that stretched from San Diego de Alcalá to San Francisco Solamo. These spectacular roof tile designs are an ideal roofing compliment to Mission, Mediterranean or Old World architectural styling, with their wide range of diverse color blends found in the España® 600 series.

Coverage	Approx. Installed Weight / Square	Pieces Per Pallet	Squares Per Pallet	Approx. Weight Per Pallet
At 3" minimum headlap, 89 field tiles will cover approx. 100 square feet of roof area.	590 lbs.	267	3	2,100 lbs.



España California Mission Blend



España Terra Cotta Flashed



*España Casa Grande Blend,
Boosted Barcelona Caps*

California Mission Blend
2ESCS6464



CRRC Rated Product - 0942-0008
Ref: .19 / Emit: .91 / SRI: 18 / Aged SRI: 24

Casa Grande Blend
2ESCS6169



CRRC Rated Product - 0942-0014
Ref: .23 / Emit: .91 / SRI: 23 / Aged SRI: 24

Terra Cotta Flashed
2ESCS6300



CRRC Rated Product - 0942-0018
Ref: .19 / Emit: .91 / SRI: 18 / Aged SRI: 19

New Clay
2ESCS6931



CRRC Rated Product - 0942-0021
Ref: .25 / Emit: .93 / SRI: 27 / Aged SRI: 28

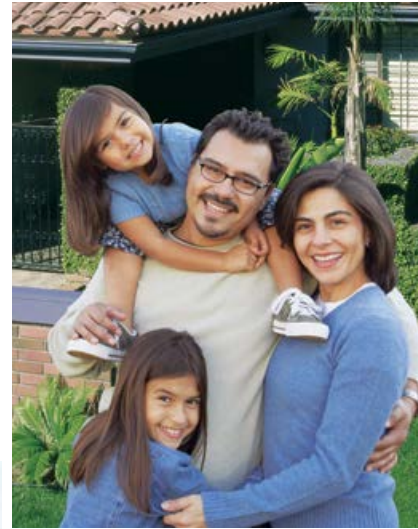

Compliant with California Title 24, 2013 Aged SRI requirement.

Actual Aged SRI # / Calculated Aged SRI #

The printed colors shown in this brochure may vary from actual available tile colors.



Duralite® Villa 600



Villa 600 embodies the architectural style of Italy and Southern France by recreating the beautiful, small barrel Mediterranean aesthetics that has made this profile one of our most popular choices.

Coverage	Approx. Installed Weight / Square	Pieces Per Pallet	Squares Per Pallet	Approx. Weight Per Pallet
At 3" minimum headlap, 87 field tiles will cover approx. 100 square feet of roof area.	580 lbs.	288	3.31	2,310 lbs.



Casa Grande Blend
2VICS6169



CRRC Rated Product - 0942-0014
Ref: .23 / Emit: .91 / SRI: 23 / Aged SRI: 24

Sedona Gold Slurry Finish
2VISS6566



CRRC Rated Product - 0942-0026
Ref: .44 / Emit: .92 / SRI: 51 / Aged SRI: 49

Pacific Red Blend Slurry Finish
2VIBS7161



CRRC Rated Product - 0942-0025
Ref: .33 / Emit: .92 / SRI: 37 / Aged SRI: 35

Terra Cotta Gold
2VICS6440



CRRC Rated Product - 0942-0023
Ref: .26 / Emit: .91 / SRI: 27 / Aged SRI: 19

Terra Cotta Flashed
2VICS6300



CRRC Rated Product - 0942-0018
Ref: .19 / Emit: .91 / SRI: 18 / Aged SRI: 19

Granite Grey
2VICS5309



CRRC Rated Product - 0942-0086
Ref: .11 / Emit: .92 / SRI: 9 / Aged SRI: 12

Compliant with
California Title 24, 2013
Aged SRI requirement.

Actual Aged SRI # / Calculated Aged SRI #

The printed colors shown in this brochure may vary from
actual available tile colors.



Villa Terra Cotta Flashed



Finishing Touches

Boral Roofing provides all of the necessary products for a durable and beautiful roof installation. Our trim tile is the most efficient and attractive way to complete your roof. In addition to rake and ridge pieces, Boral Roofing's hip starters are handmade and easy to install. All are protected by our Limited Lifetime, Fully Transferable, Non-Prorated Product Warranty* for tile.

- Precision production techniques provide a consistent look throughout the project
- Colors and textures complement field tile; no need to mix color mortar
- Easier and faster to install than mortar balls; no second steps
- Reduces labor time and expense

Cedarlite® 600 Madera 700



90° Rake



19CCL

V-Ridge



1VCCL

Tapered Eave Starter



1CECL

Duralite® Saxony® 600 & 700



90° Rake



1R9CL/1R9CS/1R9CB/

3-Sided Ridge



1R3CL/1R3CS/1R3CB

3-Sided Hip Starter



1FHCL/1FHCS/1FHCB

Apex 3-Way



13ACL/13ACS/13ACB

Duralite® España® 600



Capri Trim



1CTCS

Capri Hip Starter



1CHCS

Capri Apex 3-Way



1C3CS

Duralite® Villa 600



Capri Trim



1CTCS

Capri Hip Starter



1CHCS

Capri Apex 3-Way



1C3CS

Roof System Components

At Boral we view a roof as not a mere tile covering but a dynamic, performing system that protects, breathes and ages with the structure. By studying roof performance characteristics and failure points, we have created Roof System Components – a collection of components that, when installed properly and used comprehensively, result in a tile roof that lasts longer and increases energy savings.

- Ensures all areas of a roof are protected and utilized for optimum performance
- Improves weatherproofing and “breathability” of a tile roof
- Helps prevent water damage
- Increases airflow and ventilation
- Provides aesthetically pleasing design elements

When installing a new tile roof or reroofing, choosing to upgrade a few components can make a big difference. Make your roof a Boral® Cool Roof System by including a few select Boral components that ventilate and help protect the roof system. Choose a roof system that will perform better and last longer.

Hip & Ridge

Hip and ridge weather blocking helps prevent wind-driven rain, snow and other debris from entering the peaks and corners of a roof. Boral's vented ridge products enhance the breathability of the roof system.

Valleys

Boral's valley products are designed for tile roofs with ribs that support the tiles and channel water off the roof.

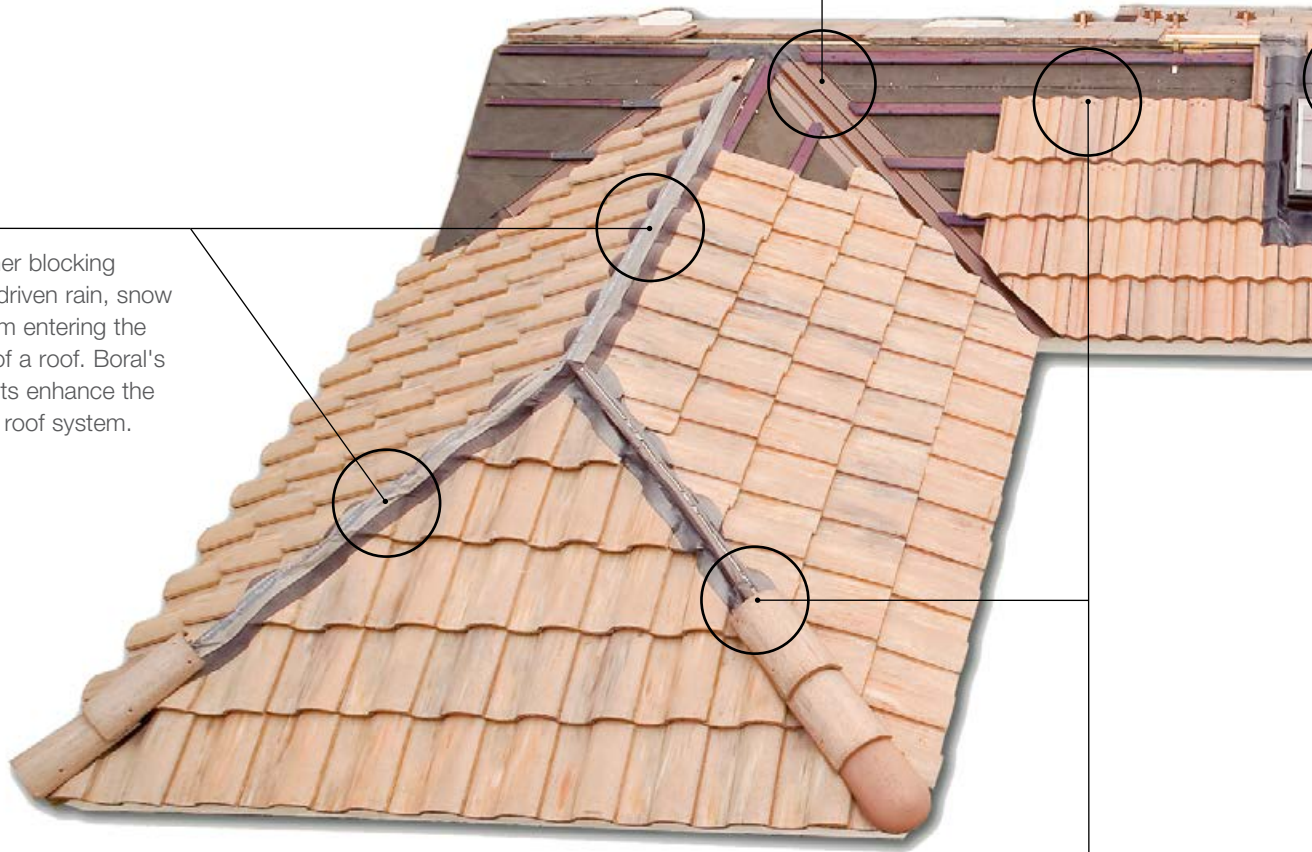

Fasteners & Tools

Boral offers the QuikDrive® roofing specific screws for fast, easy and reliable fastening.



For complete list of Roof System Components or to order catalog please visit www.BoralRoofComponents.com

Flashing

Proper flashings prevent water, snow and debris from entering joints where the walls meet the roof deck. Boral's Wakaflex® flashing material is the top choice for these critical areas of the roof.

Underlayments

Underlayments provide a secondary level of protection directly on top of the roof deck. Boral offers a range of high quality underlayments for better protection and peace of mind.

Eaves

Boral's eave products create a finished look for the roof and enhance its overall functionality. Elevating the first course of tiles to the proper height completes the overall aesthetic of the roof and helps protect against infestation.

Oxides

Oxides are pigments used to color the mortar sometimes used to seal tiles along the hip and the ridge. The oxides that Boral Roofing provides are specific to the tile colors offered and are the same pigments used in the manufacture of the tiles.

Battens

Our Elevated Battens are a crucial part of the Boral Cool Roof System and improve the performance of any tile installation. They provide positive anchoring for each tile and raise the tiles off the roof deck to provide ventilation and the unrestricted drainage of any moisture on the underlayment.

Rake & Gable End

Boral's alternative to rake tiles provide aesthetic options and protection against weather, animal infestation and debris accumulation.



Boral® Cool Roof System



Why should you choose a Boral® Cool Roof System? Highly Energy Efficient and Long Lasting.

How does it work?



Tile roofs are highly insulating and prevent much of the sun's heat from penetrating the building. Boral offers tiles in a wide range of profiles in highly reflective colors and certain tiles meet Energy Star and U.S. Green Building Council's LEED® (Leadership in Energy and Environmental Design) rating.

In addition to tile's thermal mass, the air space between the tile and the roof deck provides a layer of insulation. Boral Roofing go a step further by naturally ventilating this air space. Nearly all the heat that penetrates through the tiles is vented through the ridge. This keeps the building cooler, reducing your energy bills every year with no electrical or mechanical parts. Letting your tile roof system breathe will also make it last longer than traditional roof construction.



The most common reason for reroofing is deterioration of the roof system beneath the tiles when tiles or flashings are damaged or installed incorrectly.

The Boral Cool Roof System allows moisture that may get under the tiles or flashings to flow down and off the roof deck and quickly dry out, keeping the roof system in good condition to last longer.

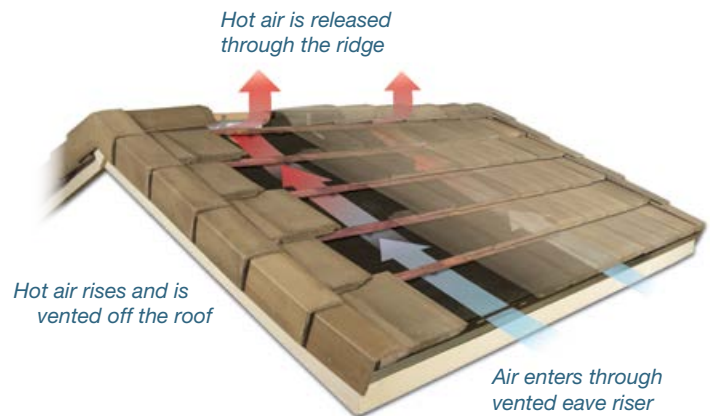

How much could you save?



According to Oak Ridge National Laboratory, an independent testing agency, a family in a typical single family house could save up to 22% per year on heating and cooling costs compared to the standard asphalt shingle roof.¹ A single family house with a Boral Cool Roof System could save an average of \$15 to \$20 per month immediately compared to a standard asphalt shingle roof and as energy rates rise year over year, your savings could increase as well and could amount up to \$20,000 over 30 years.²



Calculate how much you could save by visiting www.BoralRoofComponents.com and clicking on the **Energy Calculator** button.

Asphalt Shingle Roof	VS.	BORAL Concrete Tile Roof with Cool Roof System
<p>Attic Space 139° †</p> <p>High Cooling Needs Higher Energy Bill</p>		<p>Attic Space 94° †</p> <p>Less Cooling Needs Lower Energy Bill</p>

Up to Approximately \$20,000 in savings over 30 years²

† Temperatures measured in simulated attics using identical heat sources simulating sun's radiation to compare Boral's Cool Roof System to common asphalt shingle roof system.

¹Steep-slope Assembly Testing of Clay and Concrete Tile with and without Cool Pigmented Colors, Oak Ridge National Laboratory, 2005. Results vary based on profile of tile installed, location, weather and other factors.

²Results based on a 22 square roof in Southern California with no additional energy efficient upgrades during an average annual weather pattern, annual inflation rate of 3%, and annual energy cost increase of 3.5%. Savings may vary based on location, weather and other factors. Savings estimates are based on comparison to similar size asphalt shingle roof.

Premium

A SUPERIOR SYSTEM WITH BETTER PROTECTION AGAINST THE ELEMENTS AND SIGNIFICANT ENERGY SAVINGS

Premium quality components and construction methods provide superior durability and energy efficiency.¹ The Elevated Batten System[®] provides natural air insulation and ventilation while eliminating thousands of perforations through the water proofing underlayment. Boral TileSeal[®] underlayment has a cool white surface and adheres to the deck without nails or staples for better protection against leaks.



Preferred

A BETTER TILE ROOF SYSTEM - MORE PROTECTION PLUS ENERGY EFFICIENCY

Better quality components installed correctly provide better quality results. The Elevated Batten System[®] provides natural air insulation and ventilation while eliminating thousands of perforations through the water proofing underlayment. GatorSeal[®] adheres to the deck without nails or staples for better protection against leaks.



Contractor's Choice

AFFORDABLE SYSTEM FOR THE COST-CONSCIOUS

This is an affordable energy saving¹ roof with better quality and more security than the code minimum standard. This system upgrades a few code required components to create a roof that breathes with the innovative roof ventilation developed by Boral Roofing along with a durable, high performance underlayment at a modest price.



Vented Ridge

- Provides weather protection at hips and ridges
- Exhausts heated air from under the tiles
- Also can ventilate the attic

Underlayment

- High quality protection from the elements as a secondary water proof barrier under tiles
- Underlayments sold by Boral Roofing are backed by a manufacturer's limited warranty

Concrete Tile

- Highly efficient material due to high thermal mass and insulating air space beneath the tiles
- Class A fire rated
- Durable & long lasting³

Vented Eave Riser

- Made to fit the first row of tiles and raise them to proper height
- Provides intake of air for ventilation under the roof tiles
- Profiled styles are decorative and functional

Elevated Batten System[®] (EBS)

- Elevates tiles to allow free flow of air and water
- Provides effective thermal barrier and ventilation

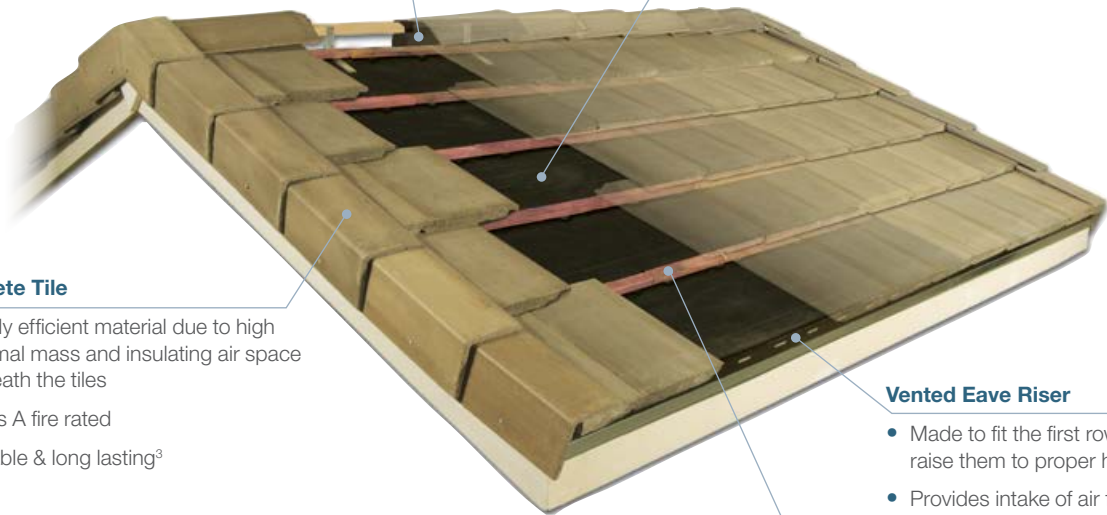

³Boral Roofing concrete tiles are covered by Limited Lifetime Warranty - see our website www.BoralRoof.com for details.

GO WITH THE BEST



Boral® Products are featured in the VISION House® at INNOVENTIONS presented by Green Builder® Media. This green home exhibit is located in INNOVENTIONS at Epcot® at the Walt Disney World® Resort.

Popular Mechanics' Winner



2011 Breakthrough Award for Home and Hardware
BoralPure® Technology
Smog Eating Concrete Tile

Edison Gold Award Winner



2012 Best New Product in Safety & Sustainability
BoralPure® Technology
Smog Eating Concrete Tile

ABOUT BORAL ROOFING

Boral Roofing is a subsidiary of Boral USA, and is the country's largest premium provider of complete roofing and re-roofing solutions for architects as well as commercial and residential builders. Boral Roofing operates 12 clay and concrete tile manufacturing plants throughout the U.S.

ABOUT BORAL USA

Headquartered in Roswell, Georgia, Boral USA is the holding company for Boral's US operations which include leading manufacturers in the building material industry. Boral USA's subsidiaries include Boral Bricks; #1 manufacturer of clay brick in the United States, Boral Roofing; the nation's leading manufacturer of clay and concrete roof tiles, Boral Stone Products, manufacturer of Cultured Stone® the most recognized brand of manufactured stone veneer, and Boral Composites Inc; manufacturer of Boral TruExterior® Trim, the #1 brand of poly-ash exterior trim products.

Build something great™ with Boral®

Stone | Bricks | Trim | Roofing

www.BoralAmerica.com

TileVision. Imagine The Possibilities



Use our online design tool to visualize tile designs and colors that best match your home design and architecture.

Save your favorites to a cart and share your vision with your family and friends on Facebook!

Sales Offices

Phoenix, ARIZONA
Corona, CALIFORNIA
Lathrop, CALIFORNIA
Stockton, CALIFORNIA
Rialto, CALIFORNIA
Denver, COLORADO

Pompano Beach, FLORIDA
Lake Wales, FLORIDA
Atlanta, GEORGIA
Kapolei, HAWAII
Henderson, NEVADA
Katy, TEXAS
Tacoma, WASHINGTON

Corporate Office

Boral Roofing
200 Mansell Court East, Suite 310
Roswell, GA 30076

Western Office

Boral Roofing
7575 Irvine Center Drive, Ste. #100
Irvine, CA 92618

Customer Service

1.800.669.TILE (8453)

Website



Download a QR Code reader app for your smartphone, then take a photo to visit our website www.BoralRoof.com

